

30 AND 50 GALLON 3 POINT HITCH OWNERS MANUAL

Since VAN'S EQUIPMENT'S beginnings we have used a generic owners manual. It was just too costly to have printed and keep on hand owner manuals specific to each size and type sprayer we manufacture.

We now have the technology in house to create sprayer specific manuals and to print them only as needed. We think we have made a good beginning, but these manuals are still in the development stage. At this point we would appreciate the input of our end user customer and our dealers as to how we can make these manuals more useful and user friendly.

This is the prototype manual. Please look over the manual and give us your input.

CALL VANS EQUIPMENT AT 1-800-765-1101 AND ASK FOR CRAIG

We appreciate your input on these manuals.

Thanks Vans Equipment



(PRICES SUBJECT TO CHANGE WITHOUT NOTICE)

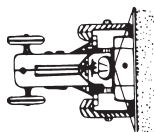

van's

EQUIPMENT COMPANY

We Appreciate You and Your Business!

P.O. BOX 3157 • 2169 SYLVESTER HIGHWAY • MOULTRIE, GEORGIA 31776-3157

(229) 985-1101

**VAN'S EQUIPMENT
BUILT FOR FARMING INTEGRITY**

WHEN SELECTING EQUIPMENT FOR FARMING THE NAME VAN'S means availability, reliability, and proven superiority. Maintaining a close association with farming customers has resulted in equipment design and manufacturing philosophy that reflects the exacting requirements of our customers.

Van's Equipment Company, Inc. appreciates your purchase of a new spray unit. This unit, is designed to give years of service with proper care. The following pages will be helpful in set-up and maintenance of your new unit.

PLEASE READ THIS MANUAL CAREFULLY BEFORE INITIAL START-UP IS ATTEMPTED.

**WE APPRECIATE YOU
AND YOUR BUSINESS**

INDEX

PAGE NO.....	DESCRIPTION
2.....	Model Description and Overview
3-4.....	Breakdown and Parts List
5.....	Pump Parts List,(Hypro 6500C standard)
6.....	Valve Parts List,(Spraying Systems AA6B standard)
7.....	Spray Gun Parts List,(Spraying Systems AA143-AL-3/4-6 standard)
8.....	Mounting and Assembly Instructions
9.....	Calibration
9-10.....	Maintanance and Precautions
11.....	Trouble Shooting
12.....	Tip Chart,(TP8003 standard)
13.....	Technical Information

30 AND 50 GALLON 3-POINT HITCH SPRAYER

The Van's 30 or 50 gallon sprayer is a versatile addition to any farmers stable of equipment. It connects directly to your three point hitch in minutes and can be used for many spraying jobs around the farm. It is ideally suited for spraying that small acreage crop as well as taking care of your garden spraying needs. You will also find that with the addition of a hose rack and handgun or boomless nozzle, you can do all your livestock spraying and disinfecting or herbicide application for weed control in small pastures or around out buildings and fence rows.

Standard Features include:

- | | |
|--|---|
| <ul style="list-style-type: none"> 1) Choice of 30 or 50 Gallon Polyethylene Tank 2) 5" Fillwell 3) Heavy Duty One Piece Frame 4) 6 Roller Hypro Pump w/Quick Coupler 5) Continuous Jet Agitation | <ul style="list-style-type: none"> 6) Variable Spacing Nozzles for Different Row Widths 7) Manual Boom Control Valve 8) Full Set 8003 Tips, Cap & Strainers 9) Fully Assembled & Factory Tested 10) Van's Exclusive 5 Year Structural Warranty |
|--|---|

CAUTION: Chemicals can be dangerous. Always follow instructions on the chemical container label. Improper selection or use of chemicals can cause serious injury to humans and the environment. Be Safe. Select the right chemical and handle it with care.



30 & 50 Gallon Sprayer available in various combinations of booms, handgun or boomless nozzle - See chart below for your model selection.

HANDGUN	Hand Gun		4 ROW FOLDING WITH HANDGUN &
	25' HOSE	4 ROW	
6 ROLLER 30 GALLON	L30CS11	L3013	L3014
6 ROLLER 50 GALLON	L50CS12	L5013	L5014

NOTE: Motor Freight Shipments Add \$10.00 per item.
Pallet and Packaging Fee.

4 ROW FOLD BREAKDOWN

REF. NO.	DESCRIPTION	PART NO.	QUANTITY	PRICE EA.
1	4 Row Folding Boom Center Section	B4	1	229.00
2	PTO Pin	00276	2	1.28
3	1/2" x 1 1/2" Bolt (4 Row Folding C.S.)	CS12112C	4	.57
3A	1/2" x 1 1/2" Bolt (Hose Rack Only)	CS12112C	2	.57
4	3/8" Lock Washer	LW38	2	.07
5	3/8" Hex Nut	HN38C	2	.09
6	1/2" Lock Nut	HLN12C	2	.45
7	1/2" Flat Washer	FW12	4	.15
8	1/2" Lock Washer	LW12	2	.11
9	1/2" Hex Nut	HN12C	2	.26
10	Left Side Boom	B4-3-1	1	57.00
11	Right Side Boom	B4-3-2	1	57.00
12	Cable Clamp	3/32 OS	4	.40
13	38" of Aircraft Cable	3/32 SS ACC	2	1.73
14	Hose Rack	H01	1	104.00
15	Hose Rack (4 Row Folding C.S.)	H6	1	70.00
16	3/8" x 1 1/4" Bolt	CS38114C	2	.24
	Boomless Nozzle Center Section L30 & L50	BBN		208.00

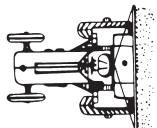
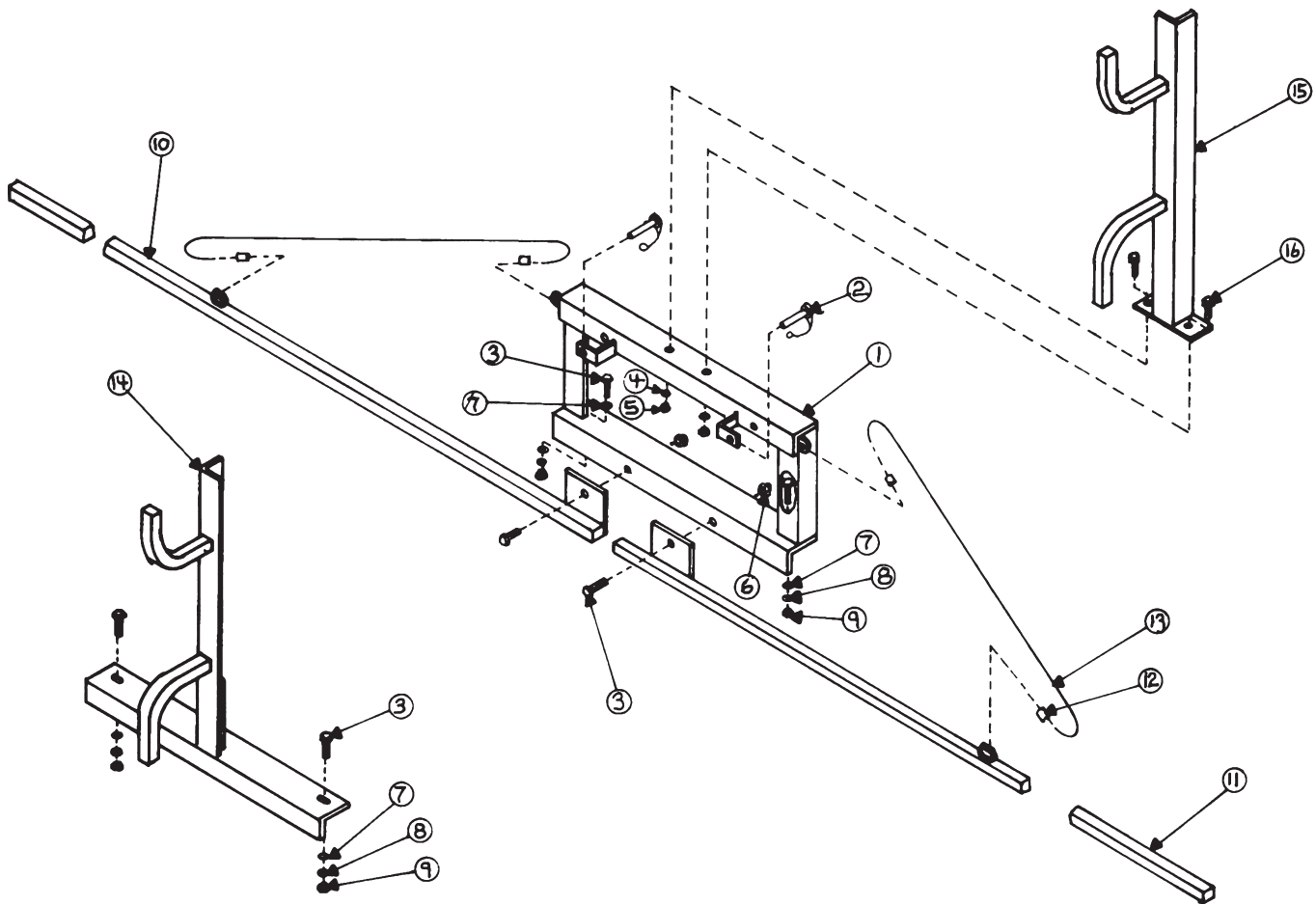

van's

EQUIPMENT COMPANY

P.O. BOX 3157 • 2169 SYLVESTER HIGHWAY • MOULTRIE, GEORGIA 31776-3157

We Appreciate You and Your Business!

(229) 985-1101

(PRICES SUBJECT TO CHANGE WITHOUT NOTICE)

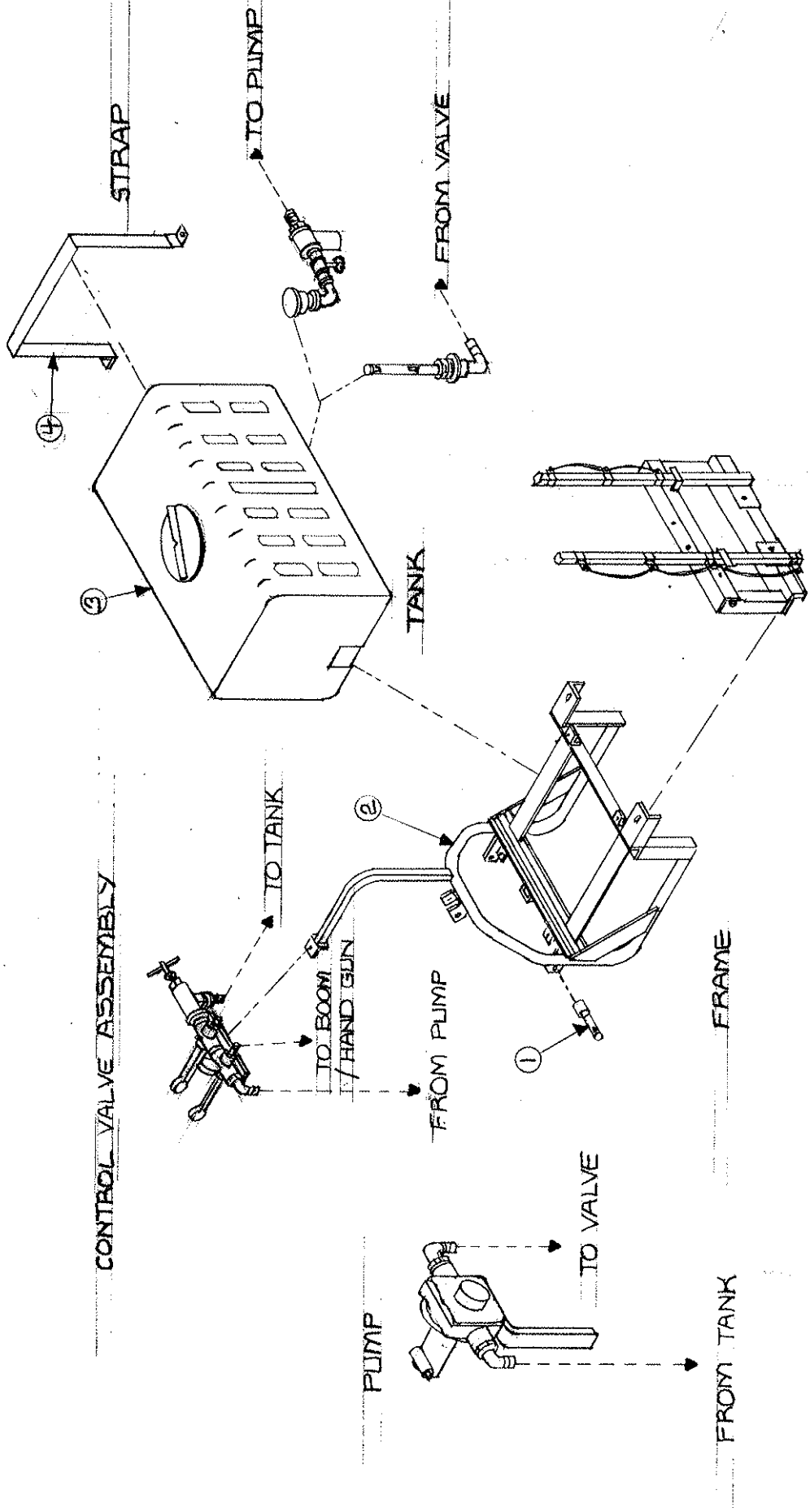

BOOM AND CENTER SECTION / HAND GUN

L30/50 W/ Hand Gun & 4 Row Folding Booms

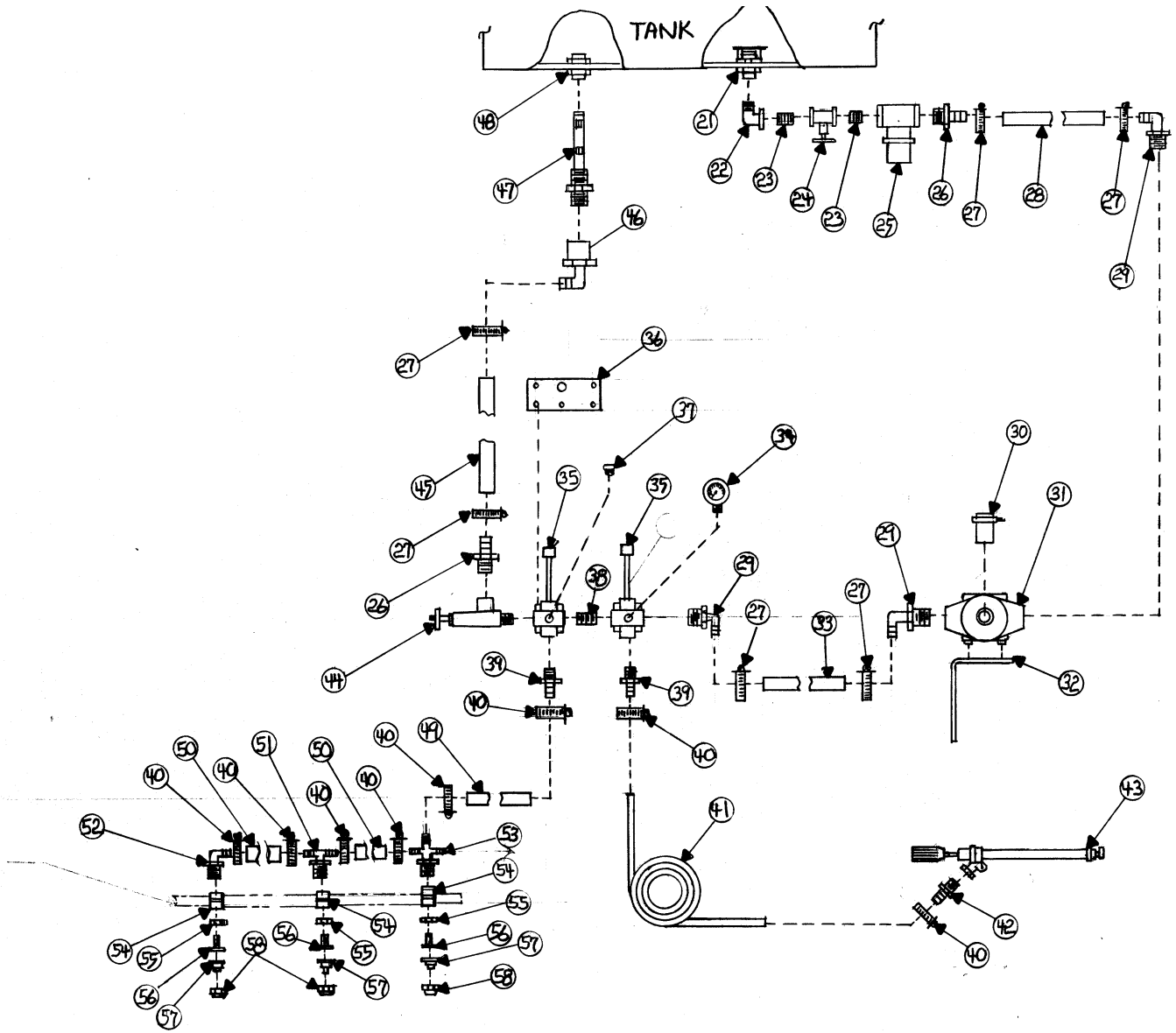

ITEM NO.	DESCRIPTION	PART NO.
1	Category pin	OO200
2	Frame	L3050
3	Tank 50 Galon PCO	47014
3	Tank 30 Galon PCO	47026
4	Strap	SP50
21	Tank Fitting 1 1/4" Anti-Vortex Poly	63065
22	Street Elbow 3/4" Nylon	SE34
23	Nipple 3/4" x Close Galvanized	GN341.5
24	Gate Valve 3/4" Brass	34BGV
25	Strainer 3/4" FPT 50 Mesh Poly	RVF1212PE40P
26	Hose Shank 3/4" MPT x 1/2" Barb Nylon	A3412
27	Hose Clamp 1/2"	8H
28	Hose Black Ag. 1/2" 300PSI	10031730
29	Hose Shank 3/4" MPT x 1/2" Barb 90 Nylon	EL3412
30	Quick Coupler 540 x 1 3/8"	1321-0006
31	Pump 6 Roller 18.2 GPM 300PSI	66500C
32	Pump Stabilizer Standard	PS
33	Hose Black Ag. 1/2" 300PSI	10031730
34	Pressure Gauge 0-160 PSI Dry 1/4" MPT	SG-160
35	ontrol Valve	AA6B
36	Valve Mounting Plate	VS6B2
37	Plug 1/4" Nylon	F14
38	Nipple 3/4" x Close Nylon	M34
39	Hose Shank 1/2" MPT x 3/8" Barb Nylon	A1238
40	Hose Clamp 3/8"	6H
41	Hose Black Ag. 3/8" 200 PSI	10031720
42	Hose Shank 3/4" MPT x 3/8" Barb Nylon	A3438
43	Spray Gun	AA143-AL-3/4-6
44	Pressure Regulator	13895-6
45	Hose Red Ag. 1/2" 200 PSI	3204-0019
46	Hose Shank 3/4" FPT x 1/2" Barb 90 Nylon	EL3412F
47	Jet Agitator	3371-0019
48	Tank Fitting 3/4" Double Thread Poly	60401
49	Hose Black Ag. 3/8" 200 PSI	10031720
50	Hose Black Ag. 3/8" 200 PSI	10031720
51	Tee Hose Connector 3/8" Poly	3NTT38
52	Elbow Hose Connector 3/8" Poly	3NTL38
53	Cross Hose Connector 3/8" Poly	3T38C
54	Boom Clamp 1" Square	AA111SQ-1
55	Connector Nut	N/A
56	Tip Strainer	8079-PP-50
57	Tip Brass	TP8003
58	Tip Cap	CP8027-NYB

Series 6500

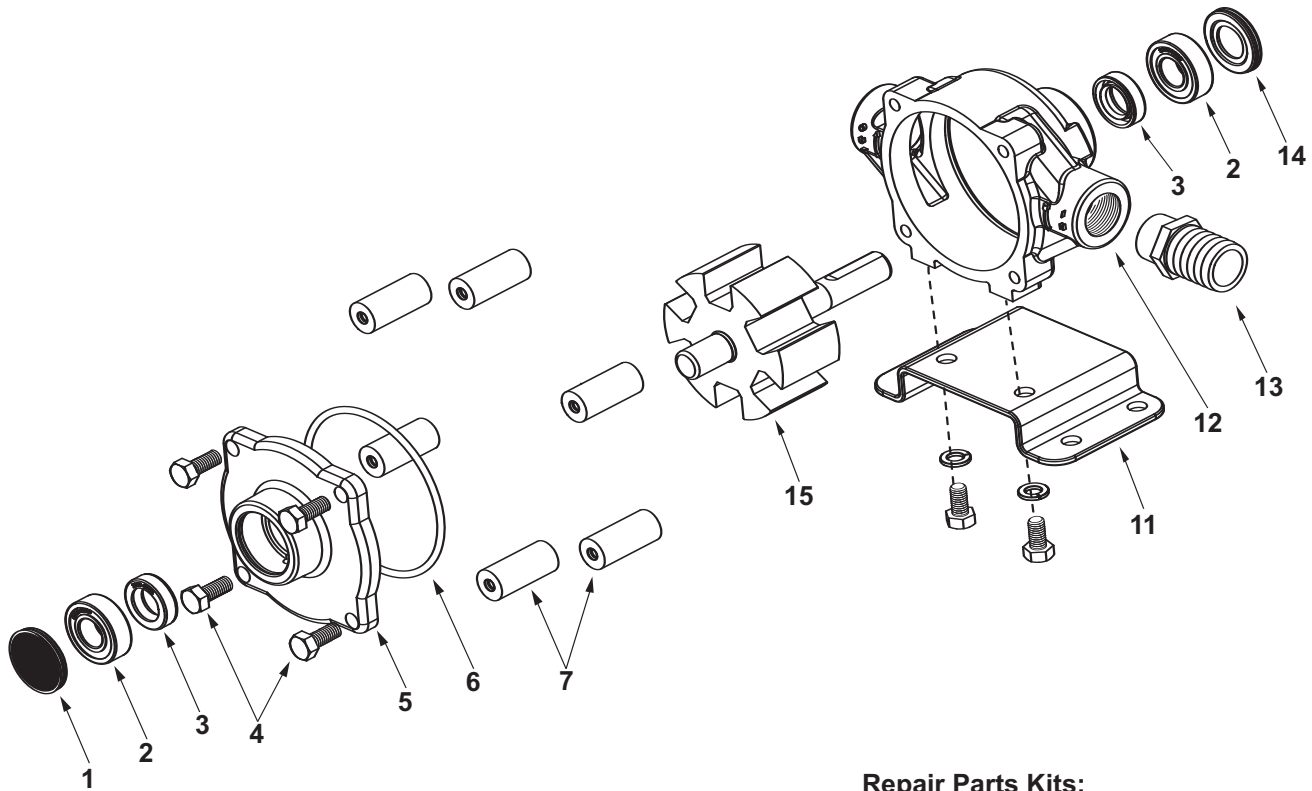

IMPORTANT:

When ordering parts, give PART NUMBER and PART DESCRIPTION. Reference Numbers are used ONLY to point out parts in the drawing and are NOT to be used as ordering numbers.

Repair Parts Kits:

No. 3430-0380 Consists of (6) Ref. 7 Super Rollers, (1) Ref. 6 O-ring, and (2) Ref. 3 Viton seals.

No. 3430-0175 Consists of (6) Ref. 7 Polypropylene Rollers, (1) Ref. 6 O-ring, and (2) Ref. 3 Viton seals.

Ref. No.	Qty. Req'd.	Part Number	Description
1	1	2300-0021	Bearing Cover
2	2	2000-0010	Sealed Ball Bearing
3	2	2107-0002	Viton Seal (Standard)
3	2	2102-0001	Buna-N Seal (Optional)
3	2	2102-0001T	Teflon-coated Buna-N Seal (Optional)
4	4	2210-0004	Bolts
5	1	0200-6600C	Endplate (Cast Iron) with Seal
5	1	0200-6600N	Endplate (Ni-Resist) with Seal
5	1	0200-6600X	Endplate (SilverCast) with Seal
6	1	1720-0008	O-ring Gasket for Endplate
7	6	1005-0004	Super Roller (Standard)
7	6	1002-0004	Polypropylene Roller (Optional)
7	6	1052-0004	Buna-N Roller (Optional)
7	6	1055-0004	Teflon Roller (Optional)

Ref. No.	Qty. Req'd.	Part Number	Description
11	1 kit	3420-0023	Base Kit - Sold Separately Includes: (1) Base, (2) Bolts and (2) Washers
12	1	0100-6600C	Body (Cast Iron) with Seal
12	1	0100-6600N	Body (Ni-Resist) with Seal
12	1	0100-6600X	Body (SilverCast) with Seal
13	1	2404-0052	1" Hose Barb
14	1	2300-0023	Shaft Bearing Cover
15	1	0300-6600C	Rotor Assembly (Cast Iron)
15	1	0300-6600N	Rotor Assembly (Ni-Resist)
15	1	0300-6600X	Rotor Assembly (SilverCast)

6B Directo Valve

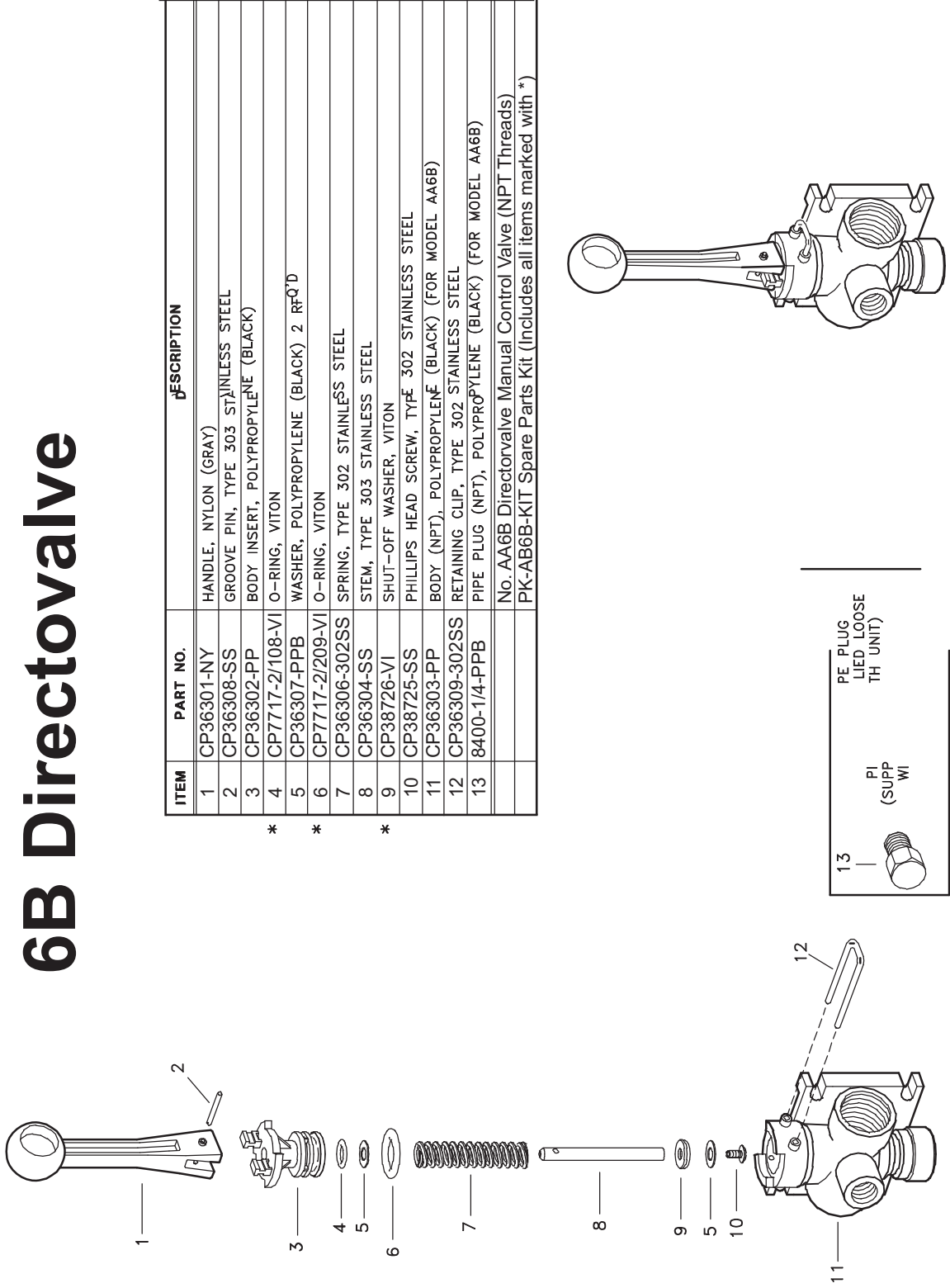

ITEM	PART NO.	DESCRIPTION
1	CP36301-NY	HANDLE, NYLON (GRAY)
2	CP36308-SS	GROOVE PIN, TYPE 303 STAINLESS STEEL
3	CP36302-PP	BODY INSERT, POLYPROPYLENE (BLACK)
4	CP7717-2/108-VI	O-RING, VITON
5	CP36307-PPB	WASHER, POLYPROPYLENE (BLACK) 2 RFQD
6	CP7717-2/209-VI	O-RING, VITON
7	CP36306-302SS	SPRING, TYPE 302 STAINLESS STEEL
8	CP36304-SS	STEM, TYPE 303 STAINLESS STEEL
9	CP38726-VI	SHUT-OFF WASHER, VITON
10	CP38725-SS	PHILLIPS HEAD SCREW, TYPE 302 STAINLESS STEEL
11	CP36303-PP	BODY (NPT), POLYPROPYLENE (BLACK) (FOR MODEL AA6B)
12	CP36309-302SS	RETAINING CLIP, TYPE 302 STAINLESS STEEL
13	8400-1/4-PPB	PIPE PLUG (NPT), POLYPROPYLENE (BLACK) (FOR MODEL AA6B)
		No. AA6B Directo Valve Manual Control Valve (NPT Threads)
		PK-AB6B-KIT Spare Parts Kit (Includes all items marked with *)

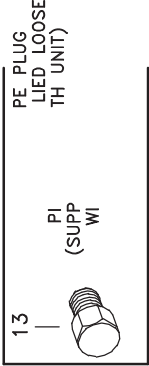

Models AA143 and AA143-AL GunJet Spray Guns

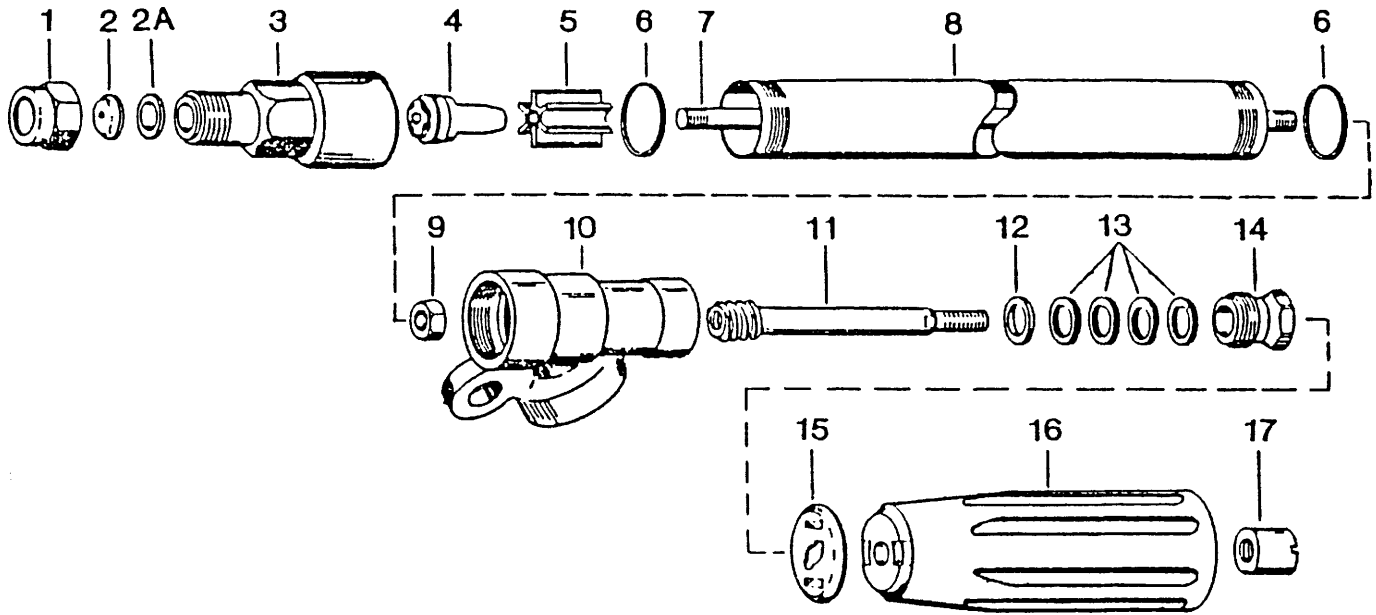

ITEM	PART NO.		DESCRIPTION
	BRASS (AA143)	ALUMINUM (AA143-AL)	
1	CP1325	CP1325-AL	Cap, Brass or Aluminum
2	D-**	D-**	Orifice Disc, Hardened Stainless Steel
* 2A	CP4743-NY	CP4743-NY	Gasket, Nylon
3	CP10566	CP10566-AL	Nozzle Housing, Brass or Aluminum
* 4	10565	10565-AL	Seat Plug, Seat Plate, Washer & Core Sub-Assembly, Brass or Aluminum
5	CP10571	CP10571-AL	Guide Vane, Brass or Aluminum
6	CP6943-AL	CP6943-AL	Gasket, Aluminum (2 Req'd)
7	CP10576	CP10576-416SS	Stem, Brass or Stainless Steel - Type 416
8	CP6604	CP6604-AL	Tubing, Brass or Aluminum
9	CP6618	CP6618-AL	Nut, Brass or Aluminum
10	CP6898-GH	CP6898-GH-AL	Inlet Body, Garden Hose (F) Conn., Br. or Alum. (For AA143-GH or AA143-143AL-GH)
	CP6898-1/2	CP6898-1/2-AL	Inlet Body, 1/2" NPT (F) Conn., Br. or Alum. (For AA143-1/2 or AA143-AL-1/2)
	CP6898-3/4	CP6898-3/4-AL	Inlet Body, 3/4" NPT (F) Conn., Br. or Alum. (For AA143-3/4 or AA143-AL-3/4)
11	CP5882	CP5882-NP	Hand Grip Stud, Brass or Brass, Nickel Plated
12	CP5883	CP5883-AL	Packing Washer, Brass or Aluminum
* 13	CP5809-LEA	CP5809-LEA	Packing, Thermo-Leather (4 Req'd)
14	CP5811	CP5811-AL	Packing Screw, Brass or Aluminum
15	CP5884-INP	CP5884-INP	Hand Grip Collar, Steel, Nickel Plated
16	CP5994-2-NY	CP5994-2-NY	Hand Grip, Nylon
17	CP5813	CP5813-AL	Hand Grip Nut, Brass or Aluminum
No. AA143-GH GunJet Spray Gun, Brass			
No. AA143-AL-GH GunJet Spray Gun, Aluminum			
No. AA143-1/2 GunJet Spray Gun, Brass			
No. AA143-AL-1/2 GunJet Spray Gun, Aluminum			
No. AA143-3/4 GunJet Spray Gun, Brass			
No. AA143-AL-3/4 GunJet Spray Gun, Aluminum			
No. AB143-Kit- Spare Parts Kit (Includes all items marked with *)			
No. AB143-AL-Kit- Spare Parts Kit (Includes all items marked with *)			

** Specify Orifice Disc Size

MOUNTING AND ASSEMBLY INSTRUCTIONS

FOR 3 POINT HITCH SPRAYERS 30 and 50 GALLON

Mount sprayer on tractor and use your top link to level frame. Use the lift arm adjustments to level tank and frame laterally. Install lift arm stabilizer to eliminate side sway while operating.

PUMP....

1. Install pump on tractor PTO shaft and make sure that the pump you are using is recommended for the PTO speed which you intend to use. When in doubt ask your dealer for assistance. Make sure the quick coupler is locked onto tractor PTO. Make sure pump stabilizer, (the L shaped bracket attached to pump), is placed so the pump will not rotate with PTO shaft.
2. Be sure to check arrows on the pump that indicate proper rotation of the pump.
3. Be sure the suction hose from tank to pump is not kinked or collapsed, and run it as straight as possible. Be sure all clamps are tight and in place.
4. Never operate any sprayer pump dry. When starting a new pump and every time it is operated thereafter, the pump should start displacing liquid within 15 seconds. If it does not stop the pump and check all hoses, valves, and strainer between the pump and tank.
5. After use, flush pump and the rest of system with clean water.
6. For winter storage or if freezing conditions will be encountered flush pump and rest of system with 50/50 mixture of water and antifreeze.

BOOM ASSEMBLY AND SET UP....

After mounting the sprayer tank, and frame unit, and the proper pump, it is very important that the sprayer booms be assembled correctly and used properly. If booms have not already been installed on your sprayer, consult your dealer.

Assuming the booms are now correctly attached to the sprayer frame, be sure feed lines are correctly connected to valve assembly. You can determine this by operating the sprayer with clear water and switching feed lines if necessary. Adjust your boom to proper operating height, in most cases nozzles should be 19-20 inches above surface to be sprayed, check with your county agent or chemical dealer to be sure. Be sure booms are level.

Look at every nozzle on your sprayer to make sure all are the same size, have tip strainers in place and are clean.

BEFORE GOING TO THE FIELD....

1. Look inside your new sprayer tank and make sure it is clean.
2. Fill tank about half full with clean water –DO NOT ADD ANY CHEMICALS AT THIS TIME.
3. Make sure the valve in the suction line on the bottom of the tank is full open.
4. Turn adjusting screw on the pressure regulator valve counter-clockwise until it is almost all the way out.

5. Start the pump slowly and increase speed of tractor PTO to about 1200 rpm while checking to make sure liquid is passing through pump and back into tank.
6. Turn the adjusting screw on pressure regulator valve clockwise and increase pressure to approximately 10 PSI above the pressure you expect to use in the field.
7. Open boom control valve and check all fittings for possible leaks. Check all hose connections make sure all clamps are tight.
8. Make very sure that at no time will pressure exceed the capacity of the gauge. This should be checked with the booms shut off and with pto at speed.
9. AT ALL TIME BE SURE YOU HAVE A RETURN WATER FLOW TO TANK. NEVER SHUT REGULATOR VALVE ALL THE WAY OFF.
10. Inspect the inside of the tank again for good agitation while the pump is running. Your VAN'S SPRAYER gives full time agitation while pump is running. If for some reason you do not have good agitation, it is possible some type foreign material is in return line or agitator. Recheck return line and agitator and clean as needed.
11. If the preceding steps have been followed and all corrective action necessary has been taken, you are now ready to calibrate your unit for field operation.

CALIBRATION....

It is necessary to calibrate your sprayer before beginning the spraying job. We will not attempt here to give you a calibration procedure, however we suggest the section in the Spraying Systems catalog on calibration, your local or state pesticide manual, or calling your local VAN'S SPRAYER DEALER. You can also look on page 11 of this manual for the application table for our standard tip, which unless you specified another tip, is included with your sprayer and is a **TP8003 brass fan tip**.

No matter what method you use, or what you use, please remember the following points:

1. Always calibrate with clean water only.
2. Always calibrate under field conditions.
3. Never rely on a tractor speedometer for accuracy.
4. Make sure all nozzles are the same size, are spraying properly, and all strainers are clean.
5. Due to long boom lines, there can be a loss of pressure between pressure gauge and tips. It is usually normal to indicate a slightly higher reading on the gauge (approximately 5-8 PSI) than that indicated on application chart. For this reason calibrate your sprayer often.

CAUTIONS AND PRE-CAUTIONS(PLEASE READ CAREFULLY)

If you have followed all the instructions up to this point, your new VAN'S SPRAYER is ready to go to work and do a good job. These last instructions can and will make your spraying job more pleasant.

- A. **NEVER OPERATE SPRAYER WITHOUT PROPER SAFETY PRECAUTIONS.**

- B. ALWAYS FILL TANK A LEAST HALF FULL AND HAVE PUMP OPERATING BEFORE ADDING CHEMICALS. IF YOU ARE USING A WETTABLE POWDER, PRE-MIX IN A BUCKET OF WATER BEFORE ADDING TO TANK.
- C. NEVER OPERATE PUMP AFTER TANK IS EMPTY –DO NOT OPERATE DRY.
- D. ALWAYS ADJUST PRESSURE REGULATOR WITH SPRAYER IN OPERATION AND NEVER EXCEED THE CAPACITY OF THE GAUGE.
- E. NEVER USE A METAL OBJECT TO CLEAN A NOZZLE, A TOOTHPICK, TOOTHBRUSH, MATCH, OR AIR WILL DO A BETTER AND SAFER JOB.
- F. WHEN TRANSPORTING YOUR SPRAYER ON A ROAD OR HIGHWAY, BE SURE TO SECURE THE BOOMS IN THE BRACKETS PROVIDED FOR THIS PURPOSE. ALWAYS USE FLASHER LIGHTS OR OTHER DEVICES TO GIVE ADEQUATE WARNING TO OTHER VEHICLES.
- G. REMEMBER—NOZZLE DO WEAR CAUSING SPRA PATTERN DISTORTION AND VARYING SPRAY VOLUME RATES. REPLACE NOZZLES AS OFTEN AS NEEDED TO ASSURE PROPER, UNIFORM SPRAY COVERAGE AND RATES. CALIBRATE DAILY. STAINLESS STEEL NOZZLES PROVIDE THE MOST WEAR RESISTANCE WHEN COMPARED TO OTHER TIP MATERIALS.
- H. ALWAYS USE CLEAN WATER AND CHECK STRAINER DAILY.
- I. CHECK AGITATION IN TANK FREQUENTLY—AT LEAST TWICE DAILY.
- J. KEEP ALL HOSES IN GOOD SHAPE –REPLACE WORN OR DAMAGED HOSE WHEN NEEDED—BE SURE SUCTION HOES IS IN GOOD CONDITION.
- K. CLEAN UP WHEN JOB IS COMPLETED. ALWAYS CLEAN SPRAYER AFTER EACH USE.
- L. NEVER CHANGE FROM ONE CHEMICAL TO ANOTHER WITHOUT THOROUGHLY CLEANING SPRAYER.

CLEANING—STORING—MAINTENANCE

The least expensive thing you can do to prolong the life of your new VAN'S SPRAYER is to keep it clean. Please follow these simple instructions after the spraying job is done.

1. Clean thoroughly –Remove any chemical residues from tank, pump, hoses, boom strainers and nozzles by flushing completely the entire system with clean water and follow with a solution of approximately ONE QUART of household AMMONIA to 25 Gallons of water.
2. Remove all nozzle tips and strainers from booms and clean thoroughly with a toothbrush or toothpick. Leave nozzle tips to soak in can of light oil or diesel fuel.
3. DRAIN TANK COMPLETELY and leave it to dry outside. Make sure all chemical has been removed. THIS IS VERY IMPORTANT WITH WETTABLE POWDERS.
4. Remove pump and make sure no liquid is left inside. Fill pump with radiator rust inhibitor and plug outlets to keep inside during storage.
5. Drain complete system and fill with antifreeze during winter storage to prevent freezing.

6. STORE COMPLETE SPRAYER IN DRY PLACE OUT OF THE WEATHER.
7. CAUTION : NEVER CHANGE FROM ONE TYPE ONE CHEMICAL TO ANOTHER WITHOUT THOROUGHLY CLEANING SPRAYER.

TROUBLE SHOOTING THE SPRAYER

PROBLEM	PROBABLE CAUSE	POSSIBLE REMEDY
Erratic pressure indication on pressure gauge	air leaking into suction line	Tighten all fittings and hoses between pump and tank
	Trash in control valve or pressure gauge	Remove and clean parts
Pressure gauge fluctuates excessively	Suction line kinked or clogged	Remove suction line and clean-check tank and strainer
	Air leak in suction hose	Replace hose
	Suction hose collapsed	Replace hose
	Pump is sucking in air through the suction line or air has not been entirely evacuated from strainer	Examine the suction hose and make sure it is firmly secured. Run the pump with outlet hose open to evacuate air from pump
Pump loses suction	Suction strainer clogged	Clean strainer and tank
	Air leak in suction hose	Replace hose
	Suction hose collapsed	Replace hose
	Pump air locked	Remove discharge line and pump liquid through pump
	Pump worn and clearances too great	Replace or repair pump
Pump does not draw water	Seals worn out or deteriorated	Replace pump seals
	One or more valves are seated improperly	Examine the valve seatings and clean them
	Suction line is plugged or collapsed clogged strainer	Examine suction line Clean strained
Noisy pump	Excessive pump speed	Slow the pump
	Air leak in suction line	Replace suction hose
	Partially clogged strainer	Clean strainer
Pump shows decreased capacity	Suction strainer clogged	Clean strainer
	Air leak in suction hose	Rplace suction hose
	Moving parts worn	Replce worn parts
	Worn seal	Replace seal
	Pump roller stuck	Clean pump inside
	Pump operating too slow	Speed up pump
	Nozzles too large for capacity of pump	Use smaller nozzles or reduce number of nozzles on boom
Pump leaks	Worn out seal	Replace seal



TeeJet® VisiFlo® Flat Spray Tips

Features:

- Tapered edge flat spray pattern for uniform coverage in broadcast spraying.
- VisiFlo color-coded version available in stainless steel, ceramic and polymer in 80° or 110° spray angles in selected sizes.
- Available in ceramic 80° capacities 01–20 and 110° capacities 01–015. See XR and XRC TeeJet® tips on pages 12 and 13 for larger capacities.
- Standard version (not color-coded) available in 15°, 25°, 40°, 50° and 65° spray angles in brass, stainless steel or hardened stainless steel.
- See page 39 for TeeJet even flat spray tips.
- Automatic spray alignment with 25612*-NYR Quick TeeJet® cap and gasket. Reference page 63 for more information.
- Automatic spray alignment for sizes 10 through 20 with 25610*-NYR Quick TeeJet cap and gasket. Reference page 63 for more information.



Tip	PSI	DROP SIZE	CAPACITY ONE NOZZLE IN GPM	CAPACITY ONE NOZZLE IN OZ./MIN.	20°										GALLONS PER 1000 SQ. FT.				
					GPA														
					4 MPH	5 MPH	6 MPH	8 MPH	10 MPH	12 MPH	15 MPH	20 MPH	2 MPH	3 MPH	4 MPH	5 MPH			
TP650050†	30		0.043	5.5	3.2	2.6	2.1	1.6	1.3	1.1	0.85	0.64	0.15	0.10	0.07	0.06			
TP800050†	35		0.047	6.0	3.5	2.8	2.3	1.7	1.4	1.2	0.93	0.70	0.16	0.11	0.08	0.06			
TP1100050†	40		0.050	6.4	3.7	3.0	2.5	1.9	1.5	1.2	0.99	0.74	0.17	0.11	0.09	0.07			
	50		0.056	7.2	4.2	3.3	2.8	2.1	1.7	1.4	1.1	0.83	0.19	0.13	0.10	0.08			
	60		0.061	7.8	4.5	3.6	3.0	2.3	1.8	1.5	1.2	0.91	0.21	0.14	0.10	0.08			
TP650067†	30		0.058	7.4	4.3	3.4	2.9	2.2	1.7	1.4	1.1	0.86	0.20	0.13	0.10	0.08			
TP800067†	35		0.063	8.1	4.7	3.7	3.1	2.3	1.9	1.6	1.2	0.94	0.21	0.14	0.11	0.09			
TP1100067†	40		0.067	8.6	5.0	4.0	3.3	2.5	2.0	1.7	1.3	0.99	0.23	0.15	0.11	0.09			
	50		0.075	9.6	5.6	4.5	3.7	2.8	2.2	1.9	1.5	1.1	0.26	0.17	0.13	0.10			
	60		0.082	10	6.1	4.9	4.1	3.0	2.4	2.0	1.6	1.2	0.28	0.19	0.14	0.11			
TP6501†	30	F	0.087	11	6.5	5.2	4.3	3.2	2.6	2.2	1.7	1.3	0.30	0.20	0.15	0.12			
TP8001	35	F	0.094	12	7.0	5.6	4.7	3.5	2.8	2.3	1.9	1.4	0.32	0.21	0.16	0.13			
TP11001	40	F	0.10	13	7.4	5.9	5.0	3.7	3.0	2.5	2.0	1.5	0.34	0.23	0.17	0.14			
	50	F	0.11	14	8.2	6.5	5.4	4.1	3.3	2.7	2.2	1.6	0.37	0.25	0.19	0.15			
	60	F	0.12	15	8.9	7.1	5.9	4.5	3.6	3.0	2.4	1.8	0.41	0.27	0.20	0.16			
TP65015†	30	F	0.13	17	9.7	7.7	6.4	4.8	3.9	3.2	2.6	1.9	0.44	0.29	0.22	0.18			
TP80015	35	F	0.14	18	10.4	8.3	6.9	5.2	4.2	3.5	2.8	2.1	0.48	0.32	0.24	0.19			
TP110015	40	F	0.15	19	11.1	8.9	7.4	5.6	4.5	3.7	3.0	2.2	0.51	0.34	0.26	0.20			
	50	F	0.17	22	12.6	10.1	8.4	6.3	5.0	4.2	3.4	2.5	0.58	0.39	0.29	0.23			
	60	F	0.18	23	13.4	10.7	8.9	6.7	5.3	4.5	3.6	2.7	0.61	0.41	0.31	0.24			
TP6502†	30	M	0.17	22	12.6	10.1	8.4	6.3	5.0	4.2	3.4	2.5	0.58	0.39	0.29	0.23			
TP8002	35	M	0.19	24	14.1	11.3	9.4	7.1	5.6	4.7	3.8	2.8	0.65	0.43	0.32	0.26			
TP11002	40	F	0.20	26	14.9	11.9	9.9	7.4	5.9	5.0	4.0	3.0	0.68	0.45	0.34	0.27			
	50	F	0.22	28	16.3	13.1	10.9	8.2	6.5	5.4	4.4	3.3	0.75	0.50	0.37	0.30			
	60	F	0.24	31	17.8	14.3	11.9	8.9	7.1	5.9	4.8	3.6	0.82	0.54	0.41	0.33			
TP6503†	30	M	0.26	33	19.3	15.4	12.9	9.7	7.7	6.4	5.1	3.9	0.88	0.59	0.44	0.35			
TP8003	35	M	0.28	36	21	16.6	13.9	10.4	8.3	6.9	5.5	4.2	0.95	0.63	0.48	0.38			
TP11003	40	M	0.30	38	22	17.8	14.9	11.1	8.9	7.4	5.9	4.5	1.0	0.68	0.51	0.41			
	50	M	0.34	44	25	20	16.8	12.6	10.1	8.4	6.7	5.0	1.2	0.77	0.58	0.46			
	60	F	0.37	47	27	22	18.3	13.7	11.0	9.2	7.3	5.5	1.3	0.84	0.63	0.50			
TP6504†	30	M	0.35	45	26	21	17.3	13.0	10.4	8.7	6.9	5.2	1.2	0.79	0.60	0.48			
TP8004	35	M	0.37	47	27	22	18.3	13.7	11.0	9.2	7.3	5.5	1.3	0.84	0.63	0.50			
TP11004	40	M	0.40	51	30	24	19.8	14.9	11.9	9.9	7.9	5.9	1.4	0.91	0.68	0.54			
	50	M	0.45	58	33	27	22	16.7	13.4	11.1	8.9	6.7	1.5	1.0	0.77	0.61			
	60	M	0.49	63	36	29	24	18.2	14.6	12.1	9.7	7.3	1.7	1.1	0.83	0.67			
TP6505†	30	C	0.43	55	32	26	21	16.0	12.8	10.6	8.5	6.4	1.5	0.97	0.73	0.58			
TP8005	35	M	0.47	60	35	28	23	17.4	14.0	11.6	9.3	7.0	1.6	1.1	0.80	0.64			
TP11005	40	M	0.50	64	37	30	25	18.6	14.9	12.4	9.9	7.4	1.7	1.1	0.85	0.68			
	50	M	0.56	72	42	33	28	21	16.6	13.9	11.1	8.3	1.9	1.3	0.95	0.76			
	60	M	0.61	78	45	36	30	23	18.1	15.1	12.1	9.1	2.1	1.4	1.0	0.83			
TP6506†	30	C	0.52	67	39	31	26	19.3	15.4	12.9	10.3	7.7	1.8	1.2	0.88	0.71			
TP8006	35	C	0.56	72	42	33	28	21	16.6	13.9	11.1	8.3	1.9	1.3	0.95	0.76			
TP11006	40	C	0.60	77	45	36	30	22	17.8	14.9	11.9	8.9	2.0	1.4	1.0	0.82			
	50	C	0.67	86	50	40	33	25	19.9	16.6	13.3	9.9	2.3	1.5	1.1	0.91			
	60	C	0.73	93	54	43	36	27	22	18.1	14.5	10.8	2.5	1.7	1.2	0.99			
TP6508†	30	C	0.69	88	51	41	34	26	20	17.1	13.7	10.2	2.3	1.6	1.2	0.94			
TP8008	35	C	0.75	96	56	45	37	28	22	18.6	14.9	11.1	2.6	1.7	1.3	1.0			
TP11008	40	C	0.80	102	59	48	40	30	24	19.8	15.8	11.9	2.7	1.8	1.4	1.1			
	50	C	0.89	114	66	53	44	33	26	22	17.6	13.2	3.0	2.0	1.5	1.2			
	60	M	0.98	125	73	58	49	36	29	24	19.4	14.6	3.3	2.2	1.7	1.3			
TP6510†	30		0.87	111	65	52	43	32	26	22	17.2	12.9	3.0	2.0	1.5	1.2			
TP8010†	35		0.94	120	70	56	47	35	28	23	18.6	14.0	3.2	2.1	1.6	1.3			
TP11010†	40		1.00	128	74	59	50	37	30	25	19.8	14.9	3.4	2.3	1.7	1.4			
	50		1.12	143	83	67	55	42	33	28	22	16.6	3.8	2.5	1.9	1.5			
	60		1.22	156	91	72	60	45	36	30	24	18.1	4.1	2.8	2.1	1.7			
TP6515†	30		1.30	166	97	77	64	48	39	32	26	19.3	4.4	2.9	2.2	1.8			
TP8015†	35		1.40	179	104	83	69	52	42	35	28	21	4.8	3.2	2.4	1.9			
TP11015†	40		1.50	192	111	89	74	56	45	37	30	22	5.1	3.4	2.6	2.0			
	50		1.68	215	125	100	83	62	50	42	33	25	5.7	3.8	2.9	2.3			
	60		1.84	236	137	109	91	68	55	46	36	27	6.3	4.2	3.1	2.5			
TP6520†	30		1.73	221	128	103	86	64	51	43	34	26	5.9	3.9	2.9	2.4			
TP8020†	35		1.87	239	139	111	93	69	56	46	37	28	6.4	4.2	3.2	2.5			
TP11020†	40		2.00	256	149	119	99	74	59	50	40	30	6.8	4.5	3.4	2.7			
	50		2.24	287	166	133	111	83	67	55	44	33	7.6	5.1	3.8	3.0			
	60		2.45	314	182	146	121	91	73	61	49	36	8.3	5.6	4.2	3.3			

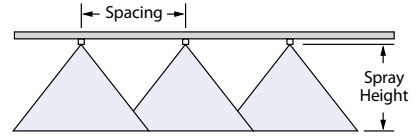

Optimum Spray Height	
65°	35"
80°	30"
110°	20"

See pages 173–187 for drop size classification, useful formulas and information.

- ### How to order:
- Specify tip number.
- Examples:
- TP8002VS – Stainless Steel with VisiFlo color-coding
 - TP11002VP – Polymer with VisiFlo color-coding
 - TP11001VK – Ceramic with VisiFlo polymer color-coding
 - TP11002-HSS – Hardened Stainless Steel
 - TP8002-SS – Stainless Steel
 - TP8002 – Brass

Note: Always double check your application rates. Tabulations are based on spraying water at 70°F (21°C). †Available in all brass, stainless steel and hardened stainless steel only.



Technical Information

Useful Formulas

$$\text{GPM (Per Nozzle)} = \frac{\text{GPA} \times \text{MPH} \times \text{W}}{5,940}$$

$$\text{GPM (Per Nozzle)} = \frac{\text{GAL}/1000\text{FT}^2 \times \text{MPH} \times \text{W}}{136}$$

$$\text{GPA} = \frac{5,940 \times \text{GPM (Per Nozzle)}}{\text{MPH} \times \text{W}}$$

$$\text{GAL}/1000\text{FT}^2 = \frac{136 \times \text{GPM (Per Nozzle)}}{\text{MPH} \times \text{W}}$$

GPM – Gallons Per Minute

GPA – Gallons Per Acre

GAL/1000FT² – Gallons Per 1000 Square Feet

MPH – Miles Per Hour

W – Nozzle spacing (in inches) for broadcast spraying

– Spray width (in inches) for single nozzle, band spraying or boomless spraying

– Row spacing (in inches) divided by the number of nozzles per row for directed spraying

Nozzle Spacing

If the nozzle spacing on your boom is different than those tabulated, multiply the tabulated GPA coverages by one of the following factors.

20"	
Other Spacing (Inches)	Conversion Factor
8	2.5
10	2
12	1.67
14	1.43
16	1.25
18	1.11
22	.91
24	.83
30	.66

Useful Formulas for Roadway Applications

$$\text{GPLM} = \frac{60 \times \text{GPM}}{\text{MPH}} \quad \text{GPM} = \frac{\text{GPLM} \times \text{MPH}}{60}$$

GPLM = Gallons Per Lane Mile

Note: GPLM is not a normal volume per unit area measurement. It is a volume per distance measurement. Increases or decreases in lane width (swath width) are not accommodated by these formulas.

Measuring Travel Speed

Measure a test course in the area to be sprayed or in an area with similar surface conditions. Minimum lengths of 100 and 200 feet are recommended for measuring speeds up to 5 and 10 MPH, respectively. Determine the time required to travel the test course. To help ensure accuracy, conduct the speed check with a partially loaded (about half full) sprayer and select the engine throttle setting and gear that will be used when spraying. Repeat the above process and average the times that were measured. Use the following equation or the table at right to determine ground speed.

$$\text{Speed (MPH)} = \frac{\text{Distance (FT)} \times 60}{\text{Time (seconds)} \times 88}$$

Speeds

Speed in MPH	Time Required in SECONDS to Travel a Distance of:		
	100 Feet	200 Feet	300 Feet
1.0	68	136	205
1.5	45	91	136
2.0	34	68	102
2.5	27	55	82
3.0	23	45	68
3.5	19	39	58
4.0	17	34	51
4.5	15	30	45
5.0	14	27	41
5.5	—	25	37
6.0	—	23	34
6.5	—	21	31
7.0	—	19	29
7.5	—	18	27
8.0	—	17	26
8.5	—	16	24
9.0	—	15	23

30"	
Other Spacing (Inches)	Conversion Factor
26	1.15
28	1.07
32	.94
34	.88
36	.83
38	.79
40	.75
42	.71
44	.68

40"	
Other Spacing (Inches)	Conversion Factor
28	1.43
30	1.33
32	1.25
34	1.18
36	1.11
38	1.05
42	.95
44	.91
48	.83

Miscellaneous Conversion Factors

One Acre = 43,560 Square Feet
= 43.56 1000FT² Blocks
= 0.405 Hectare

One Hectare = 2.471 Acres

One Gallon Per Acre

= 2.9 Fluid Ounces per 1000FT²
= 9.35 Liters Per Hectare

One Gallon Per 1000FT² = 43.56 GPA

One Mile = 5,280 Feet
= 1,610 Meters
= 1.61 Kilometers

One Gallon = 128 Fluid Ounces
= 8 Pints
= 4 Quarts
= 3.79 Liters
= 0.83 Imperial Gallon



One Pound Per Square Inch

= 0.069 bar
= 6.896 Kilopascals

One Mile Per Hour = 1.609 Kilometers Per Hour

Suggested Minimum Spray Heights

The nozzle height suggestions in the table below are based on the minimum overlap required to obtain uniform distribution. However, in many cases, typical height adjustments are based on a 1 to 1 nozzle spacing to height ratio. For example, 110° flat spray tips spaced 20 inches apart are commonly set 20 inches above the target.

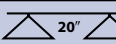
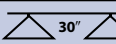
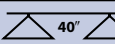
	(Inches)			
				
TeeJet® Standard, TJ	65°	22–24"	33–35"	NR*
TeeJet, XR, TX, DG, TJ	80°	17–19"	26–28"	NR*
TeeJet, XR, DG, TT, TTI, TJ, DGTJ, AI, AIXR	110°	16–18"	20–22"	NR*
FullJet®	120°	10–18"***	14–18"***	14–18"***
FloodJet® TK, TF	120°	14–16"***	15–17"***	18–20"***

* Not recommended.

** Nozzle height based on 30° to 45° angle of orientation (see page 30 of catalog).

*** Wide angle spray tip height is influenced by nozzle orientation. The critical factor is to achieve a double spray pattern overlap.

30 AND 50 GALLON 3 POINT HITCH OWNERS MANUAL



(PRICES SUBJECT TO CHANGE WITHOUT NOTICE)

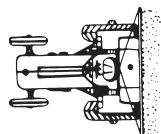

var's

EQUIPMENT COMPANY

P.O. BOX 3157 • 2169 SYLVESTER HIGHWAY • MOULTRIE, GEORGIA 31776-3157

We Appreciate You and Your Business!

(229) 985-1101