

Original by:-
C. Short,
Consulting Engineer

Update by:-
Colin Short
Chartered Civil Engineer
NRO Ireland

Retaining walls, sound, and road barriers

Objective

Design and detailing of retaining walls, acoustic, privacy, and road barriers of structural timber in compliance with EC5 Design of Timber Structures.

Summary

This article covers road division barriers, acoustic attenuation or privacy barriers, and earth retaining walls; three separate but related subjects requiring the design of essentially vertical elements with lateral actions but with differing environmental and functional requirements.

The early history of these structural types is described, and the basis of design is developed. The ultimate and serviceability limit states are identified and design values of actions and resulting load cases are developed. Methods of verification for design conditions are considered for members in relation to sawn timber and round pole sections.

Durability, structural detailing, and control in relation to retaining walls and barriers are discussed.

Retaining walls

Timber retaining walls are of two main forms, either pile and board or crib.

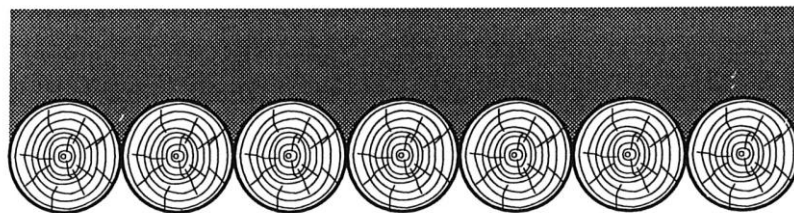

Figure 1: Simple contiguous pole wall (in plan showing retained material).

Pile and board.

The pile and board style are perhaps the oldest form of retaining wall and may have started as a simple row of poles or piles driven into the ground to form a contiguous wall of vertical elements. Stability was provided by the depth of penetration into the soil mobilising the passive resistance in the sub soils.

A later development spaced the vertical elements and filled the gap with horizontal elements of smaller cross section. In this arrangement the earth behind the wall was retained by the horizontal elements spanning onto vertical elements which were driven into the ground to mobilise the passive resistance of the sub soils.

The pole (or pile) and board style of retaining wall is a common sight today in use as temporary works on construction sites. The round small section elements are replaced by sawn boards which span horizontally onto the vertical pile. In some instances, the pile is not driven deep into the ground but braced with a raking or flying shore.

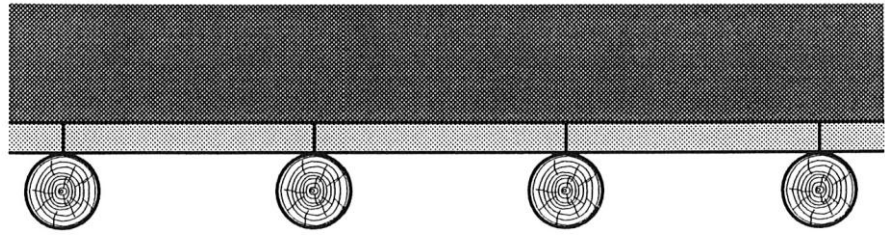

Figure 2: Plan of spaced pole and board wall.

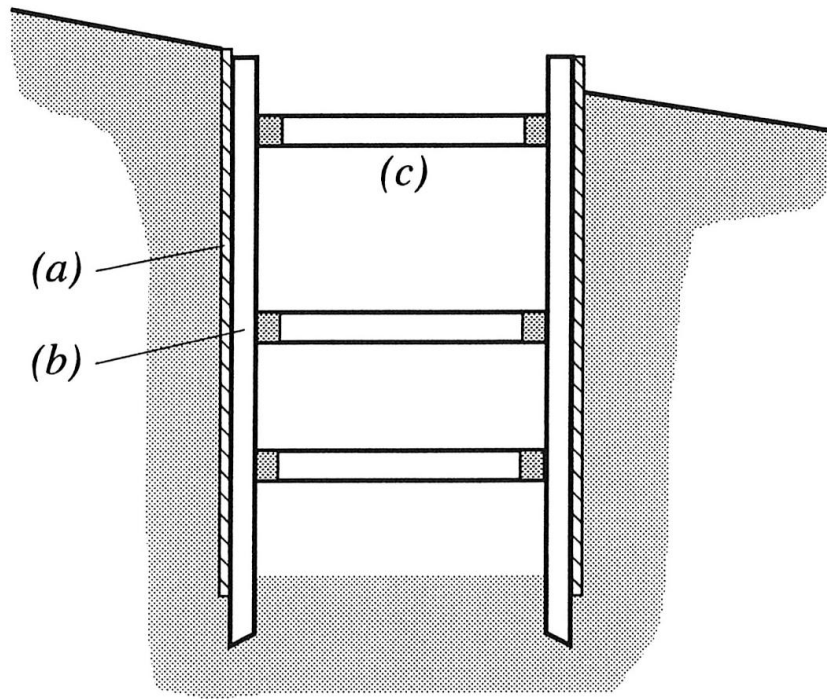

Figure 3: Trench showing a braced pile and board wall (note reduced penetration).
(a) boards, (b) pile, (c) bracing



Figure 4: An example of steel piles contiguous with boards

The design of walls retaining soils or granular material would start with the assessment of the active pressures on the wall. In some cases, full slope

stability must be considered¹. The designer can then concentrate on the design of the timber horizontal and vertical elements.

Durability is the first consideration. The species selected requires consideration of the expected life of the structure and the ability of the timber to be driven through the expected soil type. It is possible for different timber species to be selected for the pile and the board. The pile must resist the impact forces during installation. In some cases, steel shoes may be fitted to the toe of the pile and in most cases a steel cap is placed on the head of the pile for protection during the driving process. The durability period would be important for both pile and board.

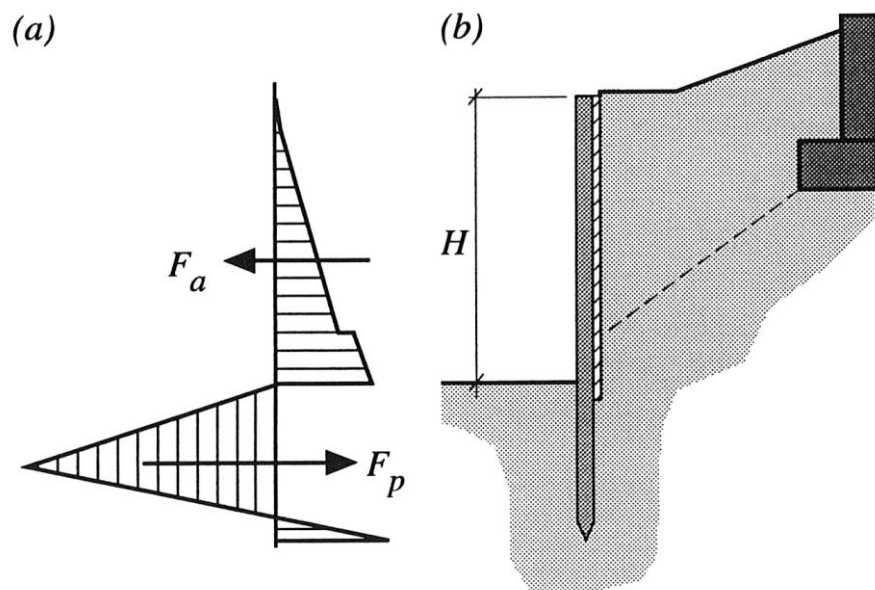

Figure 5: Pressure diagram and loads for a retaining wall. F_a = active force and F_p = passive force.

The active soil pressure behind the wall varies with depth. In many cases the simple earth and hydrostatic pressure is increased by additional loads from surcharge due to vehicle loads, soil slopes rising from the top of the wall, and building foundations close to the back of the wall. Careful analysis is required for the assessment of the imposed actions on the timber elements.

Given the active earth pressure distribution behind the wall, the boards can be designed using simple static considerations.

Friction between the board and the soil behind the board can induce a vertical force in the boards and this should be checked to ensure adequate bearing capacity on the edges of the board.

It should be verified that the stresses induced in the board by bending, shear, bearing and compressive actions are less than or equal to the strength of the timber resistance modified by the partial material factors for the service class (Class 3 high moisture content) and the load duration classes of each load combination.

The piles support the loads transferred by the boards and may be assumed to behave as a simple vertical cantilever.

¹ Refer to EN 1997 for information on these procedures.

Design example.

A retaining wall is required for a retained height H of 3,00 m and the characteristic bulk density of the backfill, $G_{b,k}$, is 18,0 kN/m³, with an internal angle of friction ν of 35°. There is a transient surcharge of $q_{t,k} = 5,00$ kN/m² to be allowed for at the top of the wall, and the Rankine coefficient is 0.27.

Retained height; $H =$	3,00	m
Backfill bulk density; $g_{b,k} =$	18,00	kN/m ³
Transient surcharge; $q_{t,k} =$	5,00	kN/m ²
Internal angle of friction: $\alpha =$	35	°
Rankine coefficient;		
$k_a = (1 - \sin(\alpha)) / (1 + \sin(\alpha)) =$	0,27	

EN 1995-1-1 Durability

The timber would be selected from the more durable species, refer to STEP articles A14 and A15 or subject to preservation treatment before installation and detailed to insure long life in service.

EN 1990 Partial factors

EC5: Part 1-1: 2.3.3.1	Unfavourable effect of permanent action; $\gamma_G =$	1,35
	Unfavourable effect of variable action; $\gamma_Q =$	1,50
2.3.3.2	Material factor; $\gamma_M =$	1,30

Board

Earth pressures at the lowest board level are

Backfill = $k_a g_{b,k} H =$	14,63	kN/m ²
Surcharge = $k_a q_{t,k} =$	1,35	kN/m ²
Height ; $H_b =$	225	mm
Breadth; $B_b =$	50	mm

Pile spacing as simple supports, span; $s = 1,30$ m

Actions or forces on board

Maximum characteristic and design forces on board	F_i kN	γ	γF_i kN
Backfill on board $F_1 =$	4,28	1,35	5,78
Surcharge on board $F_2 =$	0,40	1,50	0,59
Force on board $F_d =$	4,68		6,37

<u>Section properties</u>	
	Area; $A = H_b B_b = 11\,250 \text{ mm}^2$
	Second moment of area; $I_{zz} = (H_b B_b^3)/12 = 2,34E+06 \text{ mm}^4$
	Section modulus; $W_{zz} = (H_b B_b^2)/6 = 9,38E+04 \text{ mm}^3$
EN 338	Strength Class is C24
	Characteristic bending strength; $f_{m,k} = 24 \text{ N/mm}^2$
	Characteristic shear strength; $f_{v,k} = 2,5 \text{ N/mm}^2$
EN 1995-1-1	<u>Modification factors</u>
3.1.5	Service Class is 3
3.1.6	Load duration class is Long-term
3.2.4	Moisture content and duration of the load factor; $k_{mod} = 0,55$
	The solid timber is assumed to be normally prepared before installation by drying to near equilibrium moisture content.
3.2.2	Depth factor; $k_h = 1,25$
	<u>Design actions</u>
	Load on board; $F_{z,d} = \Sigma(\gamma F_i) = 6,37 \text{ kN}$
	Shear force; $V_{z,d} = 3,20 \text{ kN}$
	Moment; $M_{0,z,d} = F_d s / 8 = 1,04 \text{ kNm}$
	<u>Ultimate limit state</u>
	<u>Bending</u>
5.1.6	Moment; $M_{0,z,d} = 1,04 \text{ kNm}$
	Bending stress; $\sigma_{m,z,d} = M_{0,z,d} / W_{zz} = 11,05 \text{ N/mm}^2$
2.2.3.2	Bending strength; $f_{m,z,d} = k_{mod} f_{m,k} k_h / 12,69 \text{ N/mm}^2$
	Utilisation factor; $U_{m,z} = \sigma_{m,z,d} / f_{m,z,d} = 0,87 < 1$
5.2.2	Board stability is provided by the lateral pressure exerted by adjacent boards as a result of frictional transfer of vertical loads to the board edges.
	<u>Shear</u>
5.1.7	Shear stress; $\tau_{z,d} = 1,5 V_{z,d} / A = 0,43 \text{ N/mm}^2$
	Shear strength; $f_{v,d} = f_{v,k} k_{mod} / \gamma_M = 1,06 \text{ N/mm}^2$
	Utilisation factor; $U_{v,z} = \tau_{z,d} / f_{v,z,d} = 0,40 < 1$
	<u>Pile</u>
	<u>Earth pressure</u>
	Backfill pressure at base of wall is $14,6 \text{ kN/m}^2$; Surcharge at the base of wall is $1,35 \text{ kN/m}^2$
	Pile spacing; $s = 1,30 \text{ m}$
	Trial section
	Breadth; $b = 300 \text{ mm}$
	Depth; $h = 350 \text{ mm}$

STEP Article E23 - Retaining walls, sound, and road barriers

Area; $A = h b =$	105 000	mm^2
Second moment of area; $I_{yy} = b h^3 / 12$	1,07E+09	mm^4
Section modulus; $W_{yy} = b h^2 / 6 =$	6,13E+06	mm^3

	F kN	γ	γF kN	X m	M kNm
Backfill	28,54	1,35	38,52	1,00	38,52
Surcharge	5,28	1,50	7,93	1,50	11,89
Earth force	33,82		46,45		50,41

3.1.5	<u>Service Class is</u>	3
3.1.6	Load duration class is	Long-term
3.2.4	Moisture content and duration of the	
	load factor; $k_{mod} =$	0,55
3.2.2	Depth factor; $k_h =$	1,00
	Load on pile; $F_d =$	46,45 kN
	Shear force; $V_d =$	46,45 kN
	Moment; $M_{0,d} =$	50,41 kNm
	<u>Ultimate limit state</u>	
	<u>Bending</u>	
5.1.6	Moment; $M_{0,y,d} =$	50,41 kNm
	Bending stress; $\sigma_{m,z,d} = M_{0,y,d} / W_{yy} =$	8,23 N/mm^2
2.2.3.2	Bending strength;	
	$f_{m,y,d} = k_{mod} f_{m,k} k_h / \gamma_M =$	10,15 N/mm^2
	Utilisation factor; $U_{m,z} = \sigma_{m,z,d} / f_{m,z,d} =$	0,81 < 1
5.2.2	Lateral stability is provided by the bearing friction between boards and pile in the Z direction but a check should be applied for the Y direction.	
5.1.7	<u>Shear</u>	
	$\tau_{z,d} = 1,5 V_{z,d} / A =$	0,66 N/mm^2
	$f_{v,d} = f_{v,k} k_{mod} / \gamma_M =$	1,06 N/mm^2
	$U_{v,z} = \tau_{z,d} / f_{v,z,d} =$	0,63 < 1

Crib Walls

The crib wall is made from a frame work of simple elements of timber headers and stretchers forming a collection of cells filled with well graded crushed rock or natural stone materials. The headers and stretchers lock into each other with simple halving joints, providing tensile restraint to the internal forces from the mass of rock material which would otherwise redistribute to its natural angle of repose.

Some loading derives from mass of stone bearing down on the embedded timber, but the individual timber elements are designed as tensile members as described in lectures B2 and B12 with appropriate adjustments for factors derived for Service Class 3.

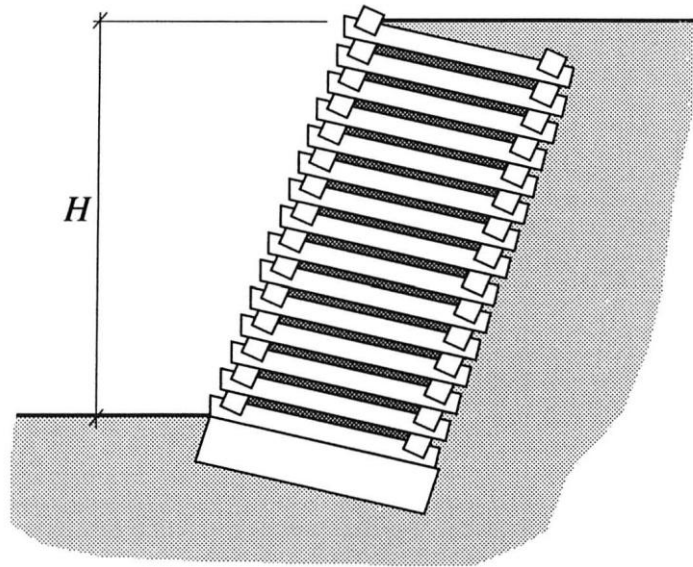

Figure 6: Typical crib retaining wall



Figure 7: Crib retaining wall beside a national roadway



Figure 8: Detail elevation of the wall in Figure 7

The wall shown in Figure 7 and Figure 8 at the time of writing had been in service for many years before the photographs were taken.

Traffic barriers

With Steel rail

Traffic barriers are typically used to separate lanes of traffic from other vehicles heading in the opposite direction or for separation of traffic from pedestrian areas. The structural form of such barriers is a profiled, functionally continuous steel rail set at typical car bumper height on timber or steel vertical elements driven or set into the ground. The height chosen in transportation guidelines (Transport Research Laboratory, 1991) to reduce the chance of the vehicle overturning on impact.

The barriers are not designed to stop vehicles instantly as they cross the barrier but slow the vehicle to a stop by absorbing the kinetic energy of the impacting vehicle or deflecting its path back into the correct direction.

The forces involved in stopping a speeding vehicle vary with the starting velocity and the deceleration rate imposed. If the structure is too stiff the deceleration rate is too high and the driver of the vehicle would be damaged, However, if the structure is not stiff enough the rate of slowing would be too low, and the car would pass into the area being protected by the barrier.

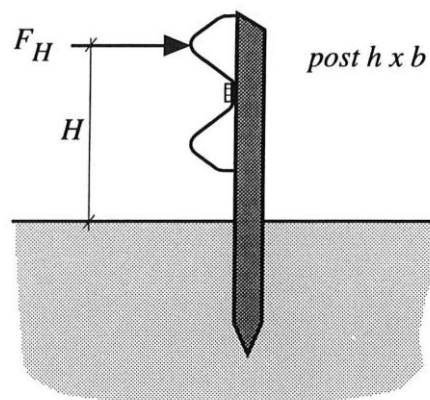

Figure 9: Traffic barrier.

Based upon test information one design publication (Transport Research Laboratory, 1991) requires the post to be designed such that the following condition is satisfied:

"Load applied 600 mm above paving or finished ground level whichever is higher such that ... is acceptable if bending moment of 9000 Nm is sustained without deflection exceeding 150 mm ".

The design case relates to accidental damage to the post, and therefore factors which allow for accidental actions and instantaneous stress levels should be used in the verification calculations.

The supports may be designed as cantilevers subjected to a design moment of 9 kNm and an appropriate shear force. Both actions are coincident at a point near to the point where the vertical support enters the ground or the foundation concrete.

Alternative with timber rail

Figure 10: Traffic barrier with timber rail

1. Durable timber rail sized to withstand accidental impact over the fixing span.
2. Corrosion resistant fixing bolt and washers; heads set below timber surface to reduce body impact damage.
3. Durable timber vertical cantilever support.
4. Concealed corrosion resistant steel bracket with bolt or dowel fastenings.
5. Concrete foundation and corrosion resistant holding down bolts; all sized to resist the accidental impact shear and coexistent bending moment.

Land division barriers, fences, and acoustic barriers.

Fencing with a variety of infill rail and panel arrangements are designed in a similar way to the Acoustic Barriers described below. The infill panel weight is generally negligible and the predominant action for consideration is that derived from the wind loading.

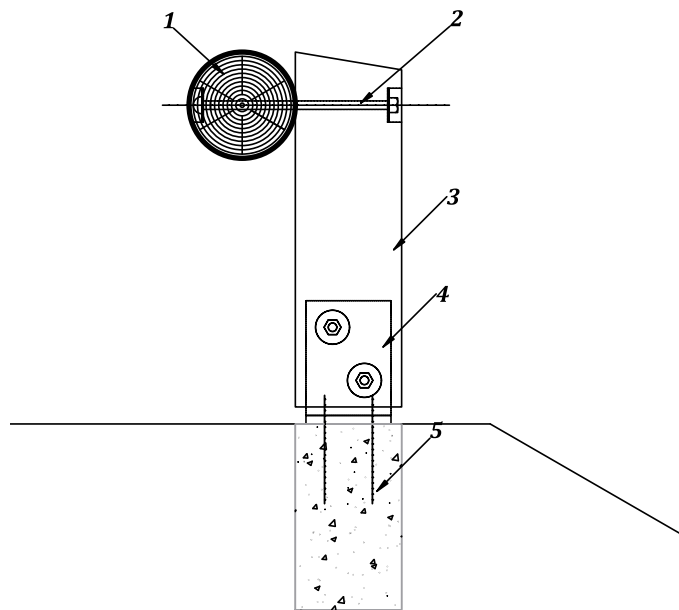
Acoustic barriers are erected between areas of high noise levels and areas which are to be protected from such noises. They are required on the boundaries of airport taxiways, aircraft test centres, motorways, and noisy industrial sites.

The barriers are designed to either deflect upwards or absorb inwards the energy waves from the noise source. In each case the timber supports are vertical elements cast into concrete foundations set in the sub soil. The actions to be catered for derive from the weight of the absorbing material in the barrier or the deflecting vanes, and the wind force on the projected area of the barrier. In general, the weight of the absorbing material is transmitted directly to the sub soil via a strip foundation and the material stability is maintained by internal ties balancing the tension forces generated.

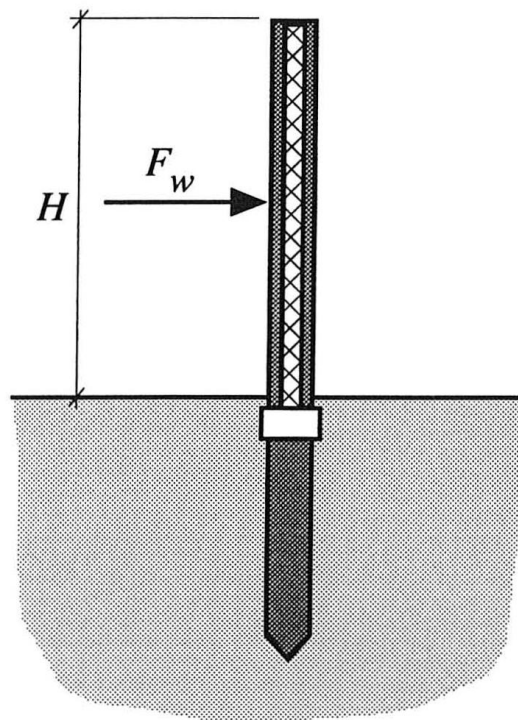

Figure 11: Typical acoustic barrier.

The design of the vertical cantilever elements in the acoustic barrier is therefore limited to consideration of the self-weight of the containing frame, deflecting vanes if present and the wind force on the barrier.

Other forms of barrier used for land division, and visual privacy are also designed and verified in a similar way to acoustic barriers.

Wind action shall be derived according to the current version of EN 1991-1-4 along with the relevant national application document for the construction site.

The forces generated are proportional to the square of the design velocity after adjustments are made for roughness of the terrain, height and proportions of the barrier, and the design life of the barrier. The resulting pressure from the wind is expressed in kN/m^2 on the projection of the barrier profile onto a vertical plane.

The force vector can be derived from the pressure and with it the design bending moment and coincident shear force. The vertical timber member can then be designed using EC5 methodology.

The overall stability of the barrier and its foundation should be verified to ensure adequate factors of safety against overturning and sliding.¹

References

Transport Research Laboratory. Highway Construction Details: H M S O, United Kingdom.

prEN 1990 Basis of structural and geotechnical design

prEN 1991-1-4 Wind actions

prEN 1997 Geotechnical design