

<p>Original by:- Hoffmeyer Technical University of Denmark</p>
--

# Wood as a building material

## Objective

To provide the concept of wood as a cellular, anisotropic material. To present the basic definitions of moisture content and density. To introduce shrinkage and swelling and their implications in structural engineering. To present the necessary background for the understanding of EC5's modification factor  $k_{mod}$ .

## Summary

The concept of wood as a cellular composite material is presented. The microstructure of the wood cell wall is discussed with a view to explaining the anisotropic nature of the physical and mechanical properties of wood. Important features of macrostructure are included; keywords are growth rings, juvenile and reaction wood, sapwood/heartwood, grain deviation, knots.

Density is the single most important physical characteristic of wood. The high variability is discussed and the concept of characteristic density presented.

Water is always present in wood. The amount of water has a profound influence on almost all wood properties. Moisture content and the fibre saturation point are defined and the sorption isotherm presented. Anisotropic shrinkage and swelling are introduced and their engineering implications discussed. Different types of distortions caused by drying are presented. An overview of moisture strength relationships and the influence of moisture level on the failure mechanisms of wood and wood based materials is discussed.

Wood and wood based materials experience a significant loss of strength over a period of time. For permanent loads, wood and wood based materials are assigned strength values that are 60% or less of their short term strength. This duration of load effect is discussed and its moisture dependency is described.

## Introduction

Wood is a natural, organic cellular solid. It is a composite made out of a chemical complex of cellulose, hemicellulose, lignin and extractives. Wood is highly anisotropic due mainly to the elongated shapes of wood cells and the oriented structure of the cell walls. In addition, anisotropy results from the differentiation of cell sizes throughout a growth season and in part from a preferred direction of certain cell types (e.g. ray cells).

The minute structure of cell walls, the aggregation of cells to form clear wood and the anomalies of structural timber represent three structural levels which all have a profound influence on the properties of wood as an engineering material. For instance, the ultrastructure level of the cell wall provides the explanation of why shrinkage and swelling of wood is normally 10 to 20 times larger in the transverse direction than in the longitudinal direction. The microstructure of clear wood holds the key to understanding why wood is 20 to 40 times stiffer in the longitudinal direction than in the transverse direction. The macrostructure of knots, fibre angle etc. provides the explanation of why tensile strength along the grain may drop from more than 100 N/mm<sup>2</sup> for clear wood to less than 10 N/mm<sup>2</sup> for structural timber of low quality.

## The structure of wood

Wood is obtained from two broad categories of plants known commercially as hardwoods (angiosperms, deciduous trees) and softwoods (gymnosperms, conifers) (Figure 1).

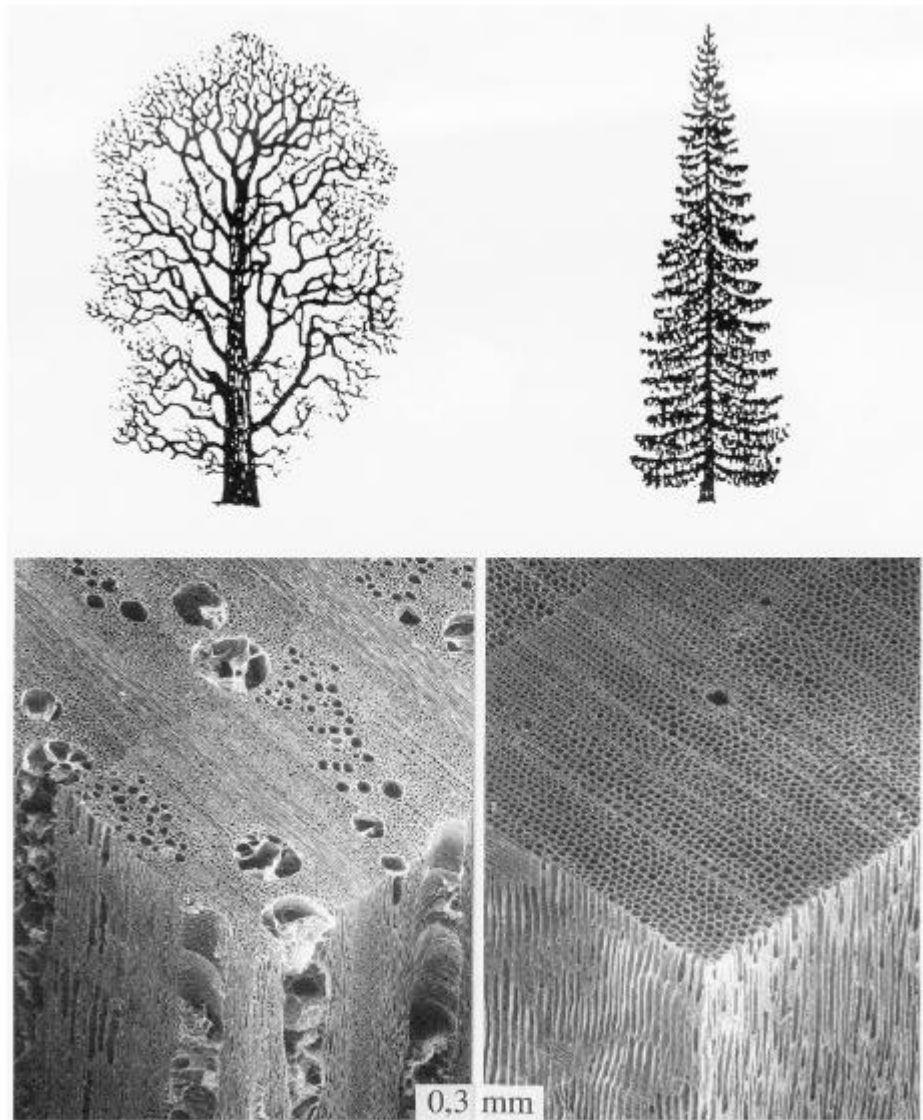

Figure 1: Timber (a) hardwoods (on the Left) and (b) Softwoods (on the Right)

Commercial timber is obtained from (a) hardwoods (*angiosperms*) or from (b) softwoods (*gymnosperms*) (Courtesy of W.A Côté). Left: oak (*Quercus robur*), right: spruce (*Picea abies*).

The observation of wood without optical aids shows not only differences between softwoods and hardwoods and differences between species, but also differences within one specimen, for example sapwood and heartwood, earlywood and latewood, the arrangement of pores and the appearance of reaction wood. All these phenomena are the result of the development and growth of wood tissue. Softwoods and hardwoods differ in cell type (Figure 2).

### Microstructure

**Softwood** shows a relatively simple structure as it consists of 90 to 95% tracheids, which are long (2 to 5 mm) and slender (10 to 50  $\mu\text{m}$ ) cells with flattened or tapered, closed ends. The tracheids are arranged in radial files, and their longitudinal extension is oriented in the direction of the stem axis. In evolving from earlywood to latewood the cell walls become thicker, while the cell diameters become smaller. At the end of the growth period tracheids with small cell lumina and small radial

diameters are developed, whilst at the beginning of the subsequent growth period tracheids with large cell lumina and diameters are developed by the tree (Figure 1 (b)). This difference in growth may result in a ratio between latewood density and earlywood density as high as 3:1.

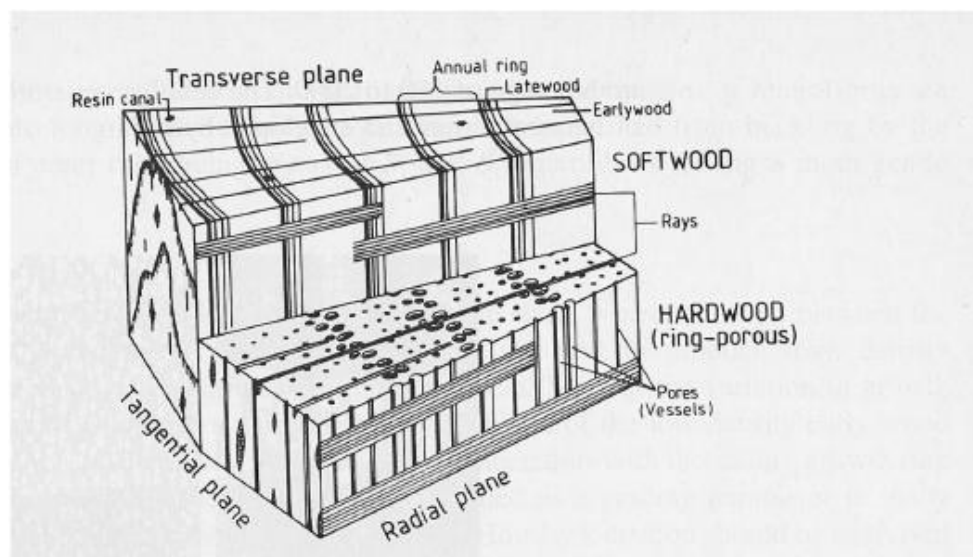

Figure 2: Models of a softwood and a hardwood block

Figure 2 shows the main planes for anisotropy (adapted from Fengel and Wegener, 1984).

The storage and the transport of assimilates take place within parenchyma cells which in softwoods are predominantly arranged in radially running rays (Figure 2). Resin canals are longitudinal and form radical cavities within the tissue of most softwoods.

The tree sap stream from one cell to another is facilitated by small openings or recesses in the fibre wall known as pits. A predominant type in softwoods is the bordered pit. These not only let water move freely but they also act as valves to prevent the spread of air into sap filled cells, in which case the water columns, extending from the roots to the crown, would rupture and the tree would eventually die. Unfortunately, pits perform the same function during drying of timber. Capillary forces are developed upon water retreat from the cell lumens through the pits, and the pit membranes move effectively to seal off the pit openings. This not only impedes the drying of wood; it also may impede greatly the susceptibility to later impregnation treatment. Such pit aspiration is the main reason why spruce, for example, is normally very difficult to impregnate.

**Hardwood** anatomy is more varied and complicated than that of softwood, but most structural concepts are analogous. Hardwoods have a basic tissue for strength containing libriform fibres and fibre tracheids. Within this strengthening tissue, conducting vessels are distributed, often with large lumina. These vessels are long pipes ranging from a few centimetres up to many metres in length and consisting of single elements with open or perforated ends. Diffuse-porous and ring-porous hardwoods can be distinguished by the arrangement of the diameter of the vessels (Figure 3). Hardwood fibres have thicker cell walls and smaller lumina than those of the softwood tracheids. The differences in wall thickness and lumen diameters between earlywood and latewood are not as extreme as in softwoods.

The number of parenchyma cells in hardwoods is higher than in softwood. Hardwoods often have very large rays and particularly in tropical hardwoods there are high percentages of longitudinal parenchyma.

### Ultrastructure

Some basic features of the wood cell wall are found to be common among many different wood species. The basic skeletal substance of the wood cell wall is cellulose which is aggregated into larger units of structure called elementary fibrils. These, in turn, are aggregated to form threadlike entities known as microfibrils. The number of cellulose chains contained in each microfibril has been estimated to be in the range of 100 to 2000. The cellulose in a microfibril is embedded in a matrix of hemicelluloses and enveloped by lignin.

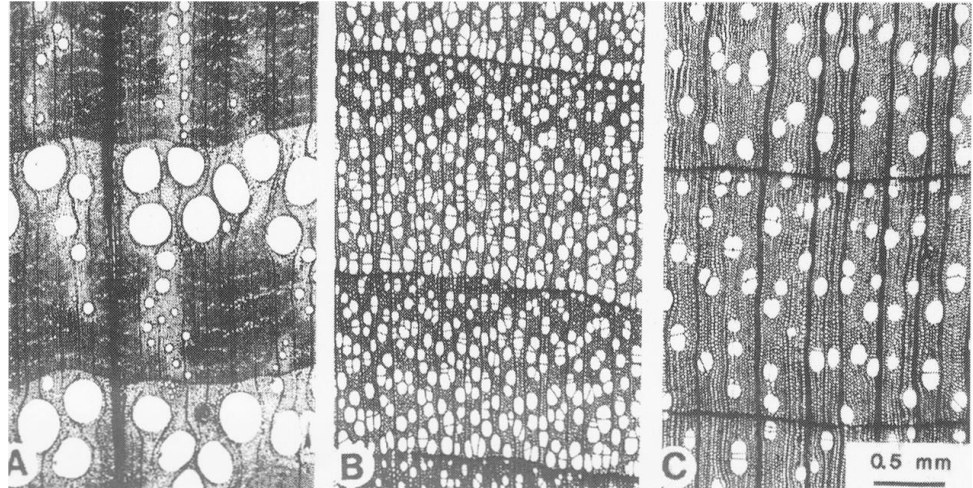

Figure 3: Light micrograph of the three types of pore patterns of growth increments in hardwoods as seen in cross section. Key: A, ring-porous (red oak); B, semiring-porous (aspen); C, diffuse-porous (yellow birch) (adapted from Parham and Gray, 1984).

The layered structure of the fibre cell wall is illustrated in Figure 4. Between the individual cells there is a layer, the middle lamella (ML), which glues the cells together to form the tissue. The middle lamella is rich in lignin and pectic substances and virtually free of cellulose. In the primary wall (P) the cellulose microfibrils are arranged in a random, irregular network. In normal wood tissue, the secondary wall consists of three fairly distinct layers S1, S2 and S3. The outermost layer, S1, is very thin (0,1 to 0,2  $\mu\text{m}$ ) and exhibits an average microfibril angle (for the layer as a whole) of about 50 to 70°. The bulk of the secondary wall is made up of the S2 layer, which is typically several micrometres thick. The microfibrils are usually oriented to the fibre axis at a relatively small angle (5 to 20°). Within the S3 layer the microfibrils are arranged with a gentle slope but not in a strict order.

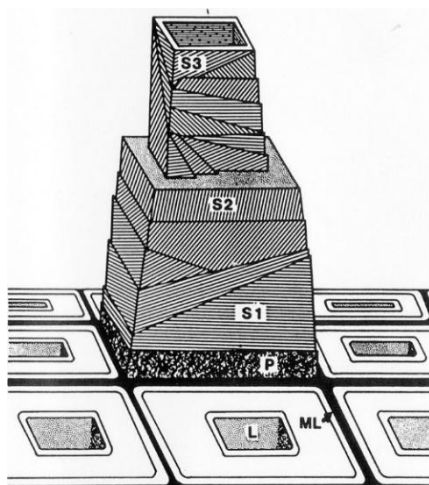

Figure 4: Schematic of the general wall architecture of normal wood fibres.

Key: L, cell lumen; ML, middle lamella; P, primary wall; and S1, S2 and S3, layers of the secondary wall (adapted from Parham and Gray, 1984).

From an engineering viewpoint, the cell wall structure is an ingenious construction. The dominant S2 layer of almost axially oriented bundles of microfibrils very effectively takes up tension forces. In compression the bundles of microfibrils are turned into long slender columns which are then prevented from buckling by the inner and outer reinforcing layers of S1 and LS3 microfibrils having a more gentle slope

## Growth rings

### Macrostructure

For most softwoods and ring-porous hardwoods there is a relationship between the width of growth rings and density. Softwoods tend to produce high density latewood bands of a relatively constant thickness. Most of the variation in growth ring width is caused by a variation in the thickness of the low density early wood bands. For most softwoods, therefore, density decreases with increasing growth ring width. This explains why ring width is included as a grading parameter in many visual grading rules currently used in Europe. However, caution should be exercised when using such relationships. The density level for a given ring width is dependent on soil type, climate conditions, silvicultural practice etc. Therefore, for softwood timber of mixed origin, ring width does not predict density with any real accuracy (Figure 5).

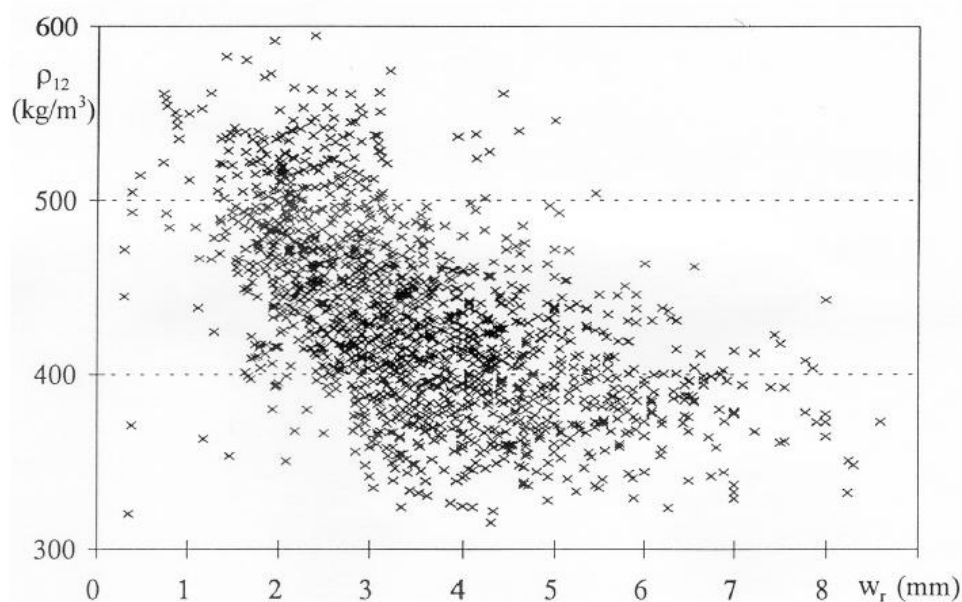

Figure 5: Density,  $\rho_{12}$  ( $\text{kg/m}^3$ )

**Density.**  $\rho_{12}$  is a function of growth ring width  $w_r$  ( $\text{mm}$ ). Results from 1600 specimens of two samples of Swedish grown and Danish grown spruce.

Ring-porous hardwoods such as oak and ash are characterized by a high concentration of open vessels produced during spring. The width of these rings is relatively constant and the variation in growth ring width is caused by a variation in the thickness of the high density latewood bands of fibre tracheids. This is why density increases with increasing ring width for most ring-porous hardwoods. There is no such relationship for diffuse-porous hardwoods such as poplar and beech.

### Sapwood and heartwood

The young outer part of a tree stem conducts the upward flow of sap from the root to the crown. This part of the bole is known appropriately as sapwood. As the cells grow old, they stop functioning physiologically; this inner part of the bole is known as heartwood.

In most species heartwood is darker in colour due to the incrustation with organic extractives. These chemicals provide heartwood with a better resistance to decay and wood boring insects. Normally heartwood formation results in a significant reduction in moisture content. This results in pit aspiration. In many hardwood species the vessels become plugged. This causes a marked reduction of permeability. In some species (e.g. spruce, beech) the heartwood is not coloured, nevertheless the extractives and physical alterations result in a difference between sapwood and heartwood.

For the purpose of wood preservation, sapwood is preferred, since the heartwood of a species such as pine (*Pinus sylvestris*) is virtually impermeable.

### Juvenile and reaction wood

The wood of the first 5 to 20 growth rings (juvenile wood) of any stem cross section exhibits properties different from those of the outer part of the stem (mature wood). This is particularly significant for softwoods. In juvenile wood, tracheids are relatively short and thin-walled with a gentle slope of the microfibrils of the S2 layer. Juvenile wood therefore typically exhibits lower strength and stiffness and much greater longitudinal shrinkage than mature, normal wood. Heartwood often holds all the juvenile wood, which possesses inferior quality with respect to mechanical properties. Therefore, in young, fast grown trees with a high proportion of juvenile wood, heartwood may be inferior to sapwood. Juvenile wood is not normally considered a problem in terms of timber engineering. However, with the increasing proportion of fast grown, short rotation plantation trees being used in the industry, the problems attached to juvenile wood will increase.

A tree reacts to exterior forces on the stem by forming reaction wood. Softwoods develop compression wood in areas of high compression, whereas hardwoods develop tension wood in high tensile regions. While the occurrence of tension wood is of minor importance to timber engineering, compression wood often creates problems. Compression wood has the appearance of wider growth rings and a higher latewood proportion than normal wood. In addition, the contrast between earlywood and latewood is less distinct than in normal, mature wood (Figure 6). The microfibrils of the S2 layer are arranged with a 45° slope which results in excessive longitudinal shrinkage, similar to juvenile wood.

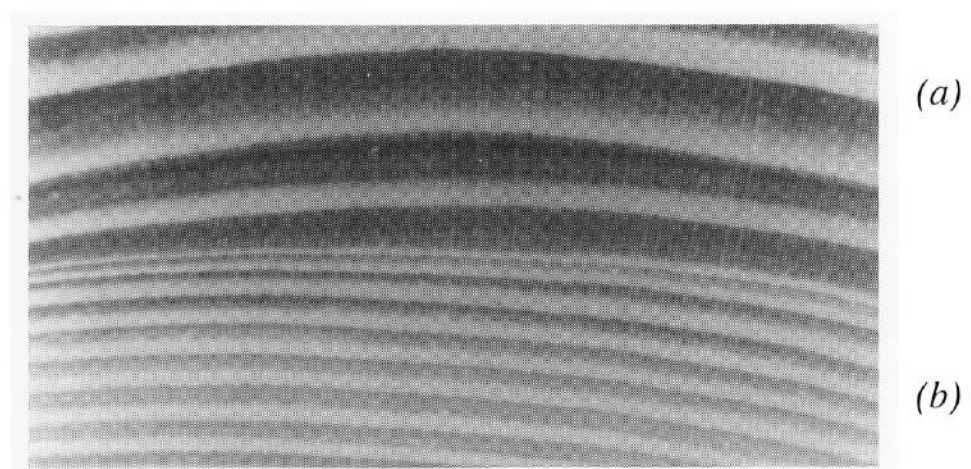

Figure 6: Compression wood in spruce (*Picea abies*).

- (a) Compression wood;
- (b) Normal wood.

Timber containing compression wood is liable to excessive distortion upon drying. Compression wood is normally of higher density so there is no loss in mechanical properties, however in a dry condition it tends to break in a brittle manner. Most visual strength grading rules limit the amount of compression wood in high quality grades.

### **Grain deviation**

Some trees grow with a cell orientation forming a helix around the stem. This spiral grain is common in certain timber species and rare in others. It is particularly pronounced in young trees. Timber sawn from these trees often exhibits grain deviation which will severely impair its use. Limits to grain deviation are included in most visual strength grading rules; typically a grain deviation of 1 in 10 is accepted for high quality timber while 1 in 5 or more is accepted for low quality timber.

### **Knots**

Knots are the parts of branches that are embedded in the main stem of the tree. The lateral branch is connected to the pith of the main stem (Figure 7). As the girth of the trunk increases, successive growth rings form continuously over the stem and branches and a cone of branch wood (the intergrown knots) develops within the trunk. Such knots are termed tight knots because they are intergrown with surrounding wood. At some points the limb may die or break off. Then subsequent growth rings added to the main stem simply surround the dead limb stub and the dead part of the stub becomes an encased knot. It is not intergrown and often has bark entrapped and is called a loose knot.

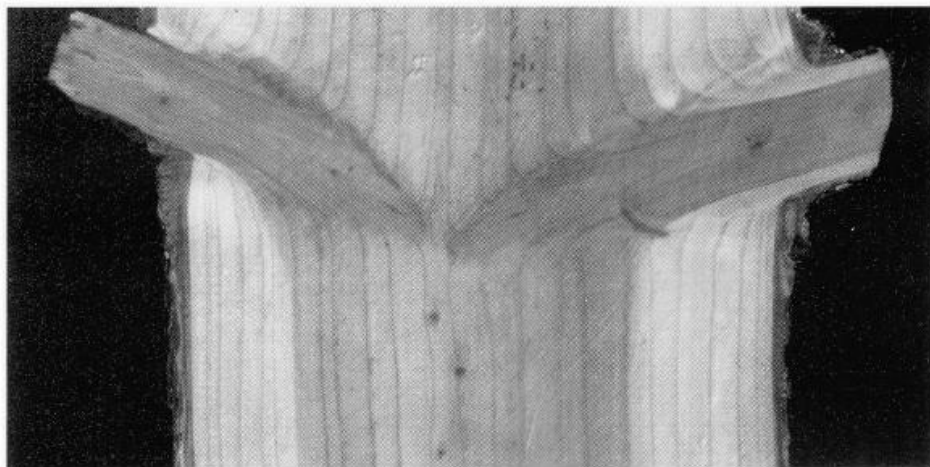

*Figure 9: The lateral branch is connected to the pith of the main stem. Each successive growth ring or layer forms continuously over the stem and branches.*

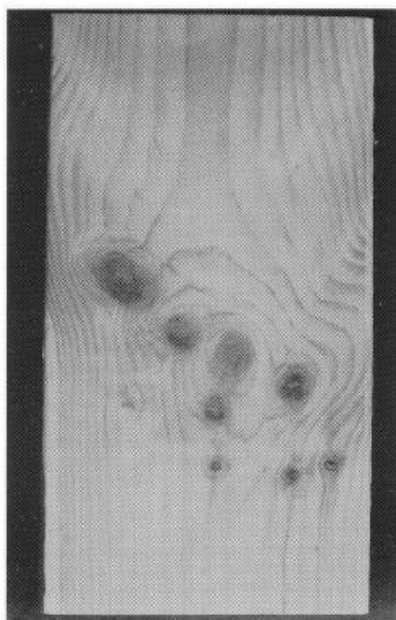

*Figure 8: A softwood board may show knots in clusters separated by the often clear wood of the internodes.*

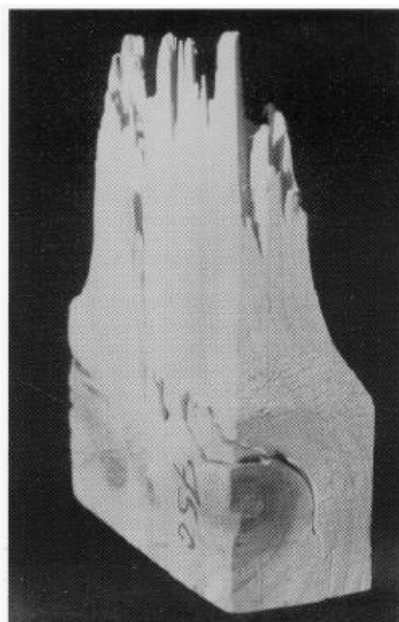

*Figure 7: Tension failure of a spruce board caused by fibre inclination around a knot.*

Softwoods are characterized by having a dominant stem from which whorls of lateral branches occur at regular intervals or nodes. Softwood boards therefore show knots in clusters separated by the often clear wood of the internodes (Figure 8). Knots are, by far, the single most important defect affecting mechanical properties (Figure 9). Knots are termed according to their appearance at the surface of the timber (Figure 10).

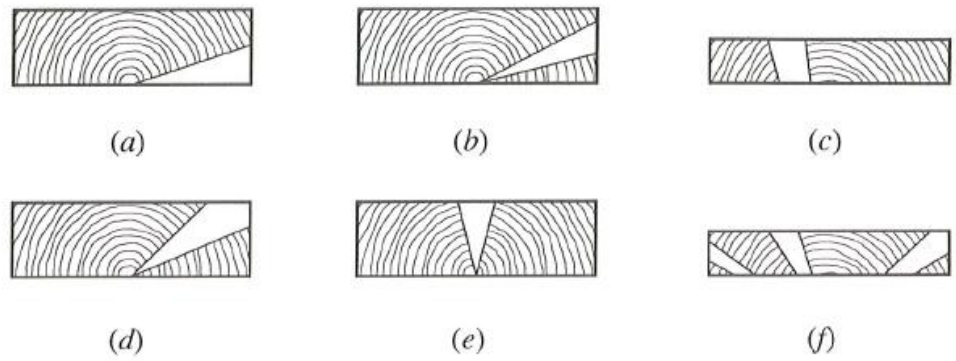

Figure 10: Knots are termed according to their appearance at the surface of the timber; (a) spike knot; (b) narrow face knot; (c) through knot; (d) arris knot; (e) wide face knot; (f) knot cluster.

### Density

Density is the most important physical characteristic of timber. Most mechanical properties of timber are positively correlated to density as is the load carrying capacity of joints. Limits to density are therefore incorporated directly in the strength class requirements of EN 338 "Structural timber - Strength classes".

Density is defined as

$$\rho = \frac{m}{V} \quad (1)$$

where  $m$  is the mass (kg) of timber and  $V$  its volume ( $m^3$ ). Density is moisture dependent, because moisture adds to the mass and may cause the volume to swell. Density  $\rho_\omega$  at a moisture content,  $\omega$  (%), is expressed as:

$$\rho_\omega = \frac{m_\omega}{V_\omega} = \frac{m_0(1+0,01\omega)}{V_0(1+0,01\beta_V\omega)} = \rho_0 \frac{1+0,01\omega}{1+0,01\beta_V\omega} \quad (2)$$

where  $m_0$ ,  $V_0$  and  $\rho_0$  are the mass, volume and density at zero moisture content.  $\rho_0$  is termed oven-dry density or simply dry density.  $\beta_V$  is the coefficient of volumetric swelling and has the units of percentage swelling per percentage increase of moisture content.

As explained in detail later, swelling only occurs when water is penetrating the cell wall layers. The moisture content corresponding to saturation of the cell wall is termed the fibre saturation point  $\omega_f$ . This corresponds to a moisture content of about 28%. Above this no swelling occurs. Below fibre saturation, swelling may for practical purposes be considered linear with moisture content.

In wood science and engineering, dry density  $\rho_0$  and density  $\rho_{12}$  at 12% moisture content are most frequently used. Density values given in EC5 are defined with mass and volume corresponding to an equilibrium at a temperature of 20 °C and a relative humidity of 65%.

The values of  $\rho_{12}$  referred to in EC5 relate to the average density  $\rho_{12,mean}$  and the characteristic density  $\rho_{12,k}$ , defined as the population 5-percentile value. For a given strength grade of timber, density is assumed to show a normal distribution with a coefficient of variation of 10%. Therefore:

$$\rho_{12,k} = \rho_{12,mean} - 1,65(0,1\rho_{12,mean}) = 0,84\rho_{12,mean} \quad (3)$$

In forestry, density is expressed as the ratio of oven-dry mass to the green volume.

$$\rho_{0g} = \frac{m_0}{V_g} \quad (4)$$

This density ( $\rho_0$ ), often termed basic density, is preferred by foresters, because it gives direct information about how much wood (dry mass production) is present in a given volume as it appears in the forest. An additional advantage of using water swollen, or green volume, is that it can be determined by the simple technique of water displacement even for irregular shaped samples. A further wood density related term is specific gravity (G). Basic specific gravity is defined as:

$$G_{0g} = \frac{\rho_{0g}}{\rho_w} = \frac{m_0}{\rho_w V_g} = \frac{\text{dry mass}}{\text{mass of displaced water}} \quad (5)$$

where  $\rho_w$  is the density of water.

The terms basic density and basic specific gravity contain the same information, and they are different only in the fundamental sense that basic specific gravity is a number ( $0 < G < 1,5$ ) and basic density has the unit of  $\text{kg/m}^3$ .

The densities  $\rho_0$  and  $\rho_{12}$  are related to basic density  $\rho_{0g}$  by

$$\rho_0 = \frac{\rho_{0g}}{1 - 28 \cdot 10^{-5} \rho_{0g}} \quad (6)$$

$$\rho_{12} = \frac{\rho_{0g}}{1 - 16 \cdot 10^{-5} \rho_{0g}} \quad (7)$$

All the various expressions for density are used frequently in literature on timber properties. Often no specific mention is made of which variant of density is being used. Caution should therefore be exercised when using such information.

The density  $\rho_c$  of the cell wall is about  $1500 \text{ kg/m}^3$ . The density of wood, therefore, is dependent on its porosity, defined as the volume fraction of cell lumina. Structural timber typically shows dry density values in the range from  $300$  to  $550 \text{ kg/m}^3$ , which gives fractional void volumes in the dry condition from  $0,80$  down to  $0,63$ .

The density of timber, even of a particular sample taken from a single location, varies within wide limits. EN 338 "Structural timber - Strength classes" defines characteristic density values for softwood in the range from  $290 \text{ kg/m}^3$  for the low strength class C14 to  $420 \text{ kg/m}^3$  for the high quality strength class C40. For visual grading, growth ring width was earlier shown to be of limited value (Figure 5). Therefore alternative methods for density assessment are needed. This topic is covered in STEP Article A6.

### Wood and moisture

Moisture content is defined as the ratio of the mass of removable water ( $m_w$ ) to the dry mass ( $m_0$ ) of the wood (Equation 8). The dry mass is obtained by oven drying at  $103 \pm 2 \text{ }^\circ\text{C}$ . Moisture content may be expressed as a fraction or in percentage terms. Throughout this chapter, wood moisture content is expressed in percentage terms.

$$\omega = \frac{m_w}{m_0} 100 = \frac{m_\omega - m_0}{m_0} 100 \quad (8)$$

For moisture contents in the range  $6$  to  $28\%$ , electric moisture meters are available, which are easy and quick to use. The accuracy of the best meters is of the order  $\pm 2\%$  which is quite sufficient for practical engineering applications. The two principles currently in use are, firstly, a DC based measurement of the moisture dependent resistivity between two electrodes hammered into the wood and secondly an AC based assessment of the moisture dependent dielectric properties of wood in an electric field created by two electrodes resting on the wood surface. Both types of meter require calibration and the AC meters only measure the moisture content in the top layer of the wood.

When wood is dried from a green condition, water is first lost from the cell lumens. This water is not associated at the molecular level with wood and is termed free water. The water held within the cell wall is termed bound water as it is held to the cell wall substance with hydrogen bonds and van der Waals forces. The removal of water from the cell wall thus requires greater energy than removal of free water.

The moisture content,  $\omega_f$ , when the cell wall is saturated with moisture, but no free water exists in the cell lumen, is termed the fibre saturation point (FSP). The FSP for most species is in the range of 25 to 35%; for most practical purposes 28% is a convenient average.

The fibre saturation point is of considerable engineering significance since below this point there will be dramatic changes in most physical and mechanical properties. Above the FSP most properties are approximately constant.

Wood is hygroscopic and thus continually exchanges moisture with its surroundings. For any combination of temperature and humidity in the environment there will be a corresponding moisture content of the wood where the inward diffusion of moisture equals the outward movement. This moisture content is referred to as the equilibrium moisture content  $\omega_\psi$ . Wood, however, is rarely in a state of moisture equilibrium as the climatic conditions of the environment are constantly changing. The level of moisture content and even the magnitude and speed of moisture fluctuations have a profound influence on almost all engineering properties of wood.

A sorption isotherm represents the relationship between moisture content  $\omega_\psi$  and relative humidity  $\psi$  at constant temperature  $T$ . At a specific relative humidity  $\psi$  the equilibrium moisture content  $\omega_\psi$  depends on whether equilibrium is reached as a result of desorption or as a result of adsorption. The adsorption isotherm (A) is always lower than the corresponding desorption isotherm (D). The A/D ratio at room temperature generally ranges between 0,8 and 0,9. Sorption hysteresis in timber is beneficial from an engineering viewpoint. This is because wood exposed to cyclic humidity conditions shows smaller changes in moisture content for given humidity changes than would be the case if there were no hysteresis. Sorption hysteresis reduces the effective slope  $d\omega/d\psi$  of the actual sorption isotherm and the dimensional changes associated with humidity changes.

Figure 11 shows sorption isotherms for spruce; these curves may also for practical purposes be taken as representative of pine and fir. The equilibrium moisture content of panel products like plywood and particleboard are also adequately described by Figure 11. However, extensive chemical treatment or heat treatment during production of panel products like fibreboards may significantly reduce the equilibrium moisture level of such products.

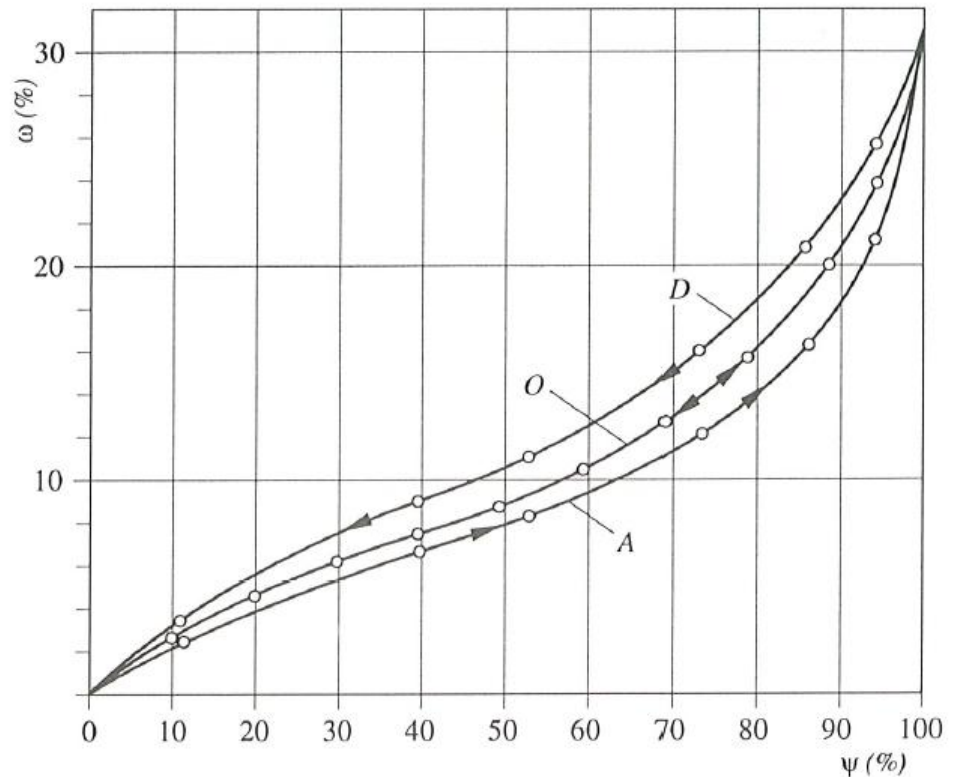

Figure 11: Sorption isotherms for spruce at 20 °C (Stamm 1964). Moisture content ( $\omega$ ) versus relative humidity ( $\psi$ ). A: adsorption; D: desorption; O: oscillating sorption.

Considerable time is required before timber will come to equilibrium with a surrounding constant climate. For example, 50 x 100 mm spruce timber at  $\omega = 20\%$  may need more than 4 weeks at 20 °C and  $\psi = 54\%$  before the centre will reach the corresponding equilibrium moisture content of  $\omega = 10\%$ . Therefore, the moisture content of a component in a timber structure will approach the equilibrium moisture content corresponding to the average temperature and relative humidity over a period of weeks rather than being affected by short cycles of high or low humidity.

### Shrinkage and swelling

Moisture has such an affinity to the wood cell wall substance that it can force its way into this virtually non-porous material. By so doing, it pushes the microfibrils apart. The resultant swelling of the cell wall can for practical purposes be assumed to be equivalent to the volume of the adsorbed water. During swelling the volume of the cell lumens stays constant. This implies that the volumetric swelling of timber equals the volume of the adsorbed water.

When moisture is removed from the cell wall, timber shrinks. Shrinkage and swelling within the normal moisture range for timber structures are termed movements.

The directional movements are first and foremost dependent on the microfibrillar orientation of the dominant S2 layer of the fibre cell wall. Since the microfibrils are normally inclined at a low angle to the longitudinal direction (Figure 4), almost all movements show in the transverse directions. The anisotropy between transverse and longitudinal movements is of the order 20:1. Juvenile wood and compression wood exhibit microfibrillar angles much larger than normal wood, which result in much

larger longitudinal movements. In compression wood the helical angle is often of the order  $45^\circ$  which results in equally large movements in the longitudinal and transverse directions (Figure 12).

Anisotropy in timber's water relationships exists even within its transverse direction. The tangential movements may, for practical purposes, be taken as twice the radial movements. Therefore, although microfibrillar angle is of major importance, it is quite apparent that other factors are also important. For most engineering purposes, however, it is unnecessary to differentiate between the two transverse directions, and transverse movement is often taken as the average value.

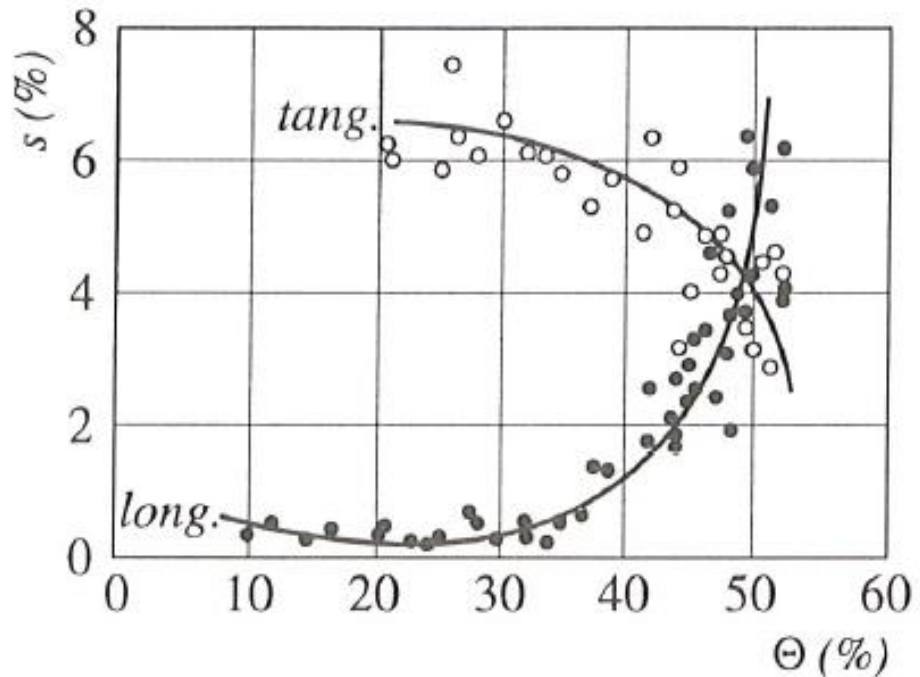

Figure 12: Longitudinal (L) and tangential (T) shrinkages (%) from green to oven-dry condition in relation to mean fibril angle ( $\theta$ ). Species is *Pinus jeffreyi* (Maylan, 1968).

Changes in dimensions tend to be linear with moisture in the range of 5 to 20% moisture content. In this range movements may be calculated from

$$h_2 = h_1 \left[ 1 + \frac{\beta}{100} (|\omega_2 - \omega_1|) \right] \quad (9)$$

where  $h_1$  and  $h_2$  are the dimensions (thicknesses) at moisture contents  $\omega_1$  and  $\omega_2$  respectively.  $\beta$  is the coefficient of swelling (positive) or shrinkage (negative). Units are %/‰.

If no species-specific value of the coefficient of movement is known, an approximation may be used. The coefficient of volumetric movement can be considered to be equal to the numeric value of the density times  $10^{-3}$ . In other words, the volume of timber of a density equal to  $400 \text{ kg/m}^3$  swells 0,4% for each 1% increase in moisture content. This is based on the volumetric swelling equalling the volume of water uptake. The coefficient of longitudinal movement,  $\beta_0$ , is usually negligible, in which case the coefficient of transverse movement,  $\beta_{90}$ , is equal to half the coefficient of volumetric movement.

For most species, including spruce, pine, fir, larch, poplar and oak, engineering values of  $\beta_0$  and  $\beta_{90}$  can be taken as  $\beta_0 = 0,01$  and  $\beta_{90} = 0,2$ , where  $\beta$  is given as percentage movement for 1% change of moisture content. For dense species like beech (*Fagus sylvatica*) and ekki (*Lophira alata*) a  $\beta_{90} = 0,3$  should be used.

In plywood, the movements in the panel plane are of the same order as the longitudinal movements of timber. For other composite wood products, such as particleboards and fibreboards, these movements are very dependent on the particular panel type and production technique. In the transverse direction of panel products, the reversible movements are of the same order as those of timber.

However, many panel products, which have been subjected to high compression stresses during production, will show additional, irreversible thickness swelling or "spring back".

When wood is restrained from expanding (e.g. in bolted joints), the uptake of moisture induces internal stresses. Due to the viscoelastic/plastic nature of wood such stresses will eventually relax and irreversible dimensional changes occur. When wood returns to its original moisture content the dimensions have shrunk, and the bolted joint may then be a loose fit and have lost some of its capacity. It is therefore important in engineering design to retain access to such construction details which may need tightening up.

In order to minimize the problems of dimensional movements timber should preferably be used at a moisture content corresponding to the relative humidity of its environment. Within buildings, timber of a moisture content higher than 20 to 22% should only be used as an exception and only in such cases where adequate and quick drying of the structure is obtained without risks of biological degradation or permanent set due to mechanosorptive creep.

In the case of large timber members, it is not always possible to neglect longitudinal movements. If, as an example, the moisture content of the upper and lower part of a glulam beam varies, it may result in significant vertical movements. A roof beam laid in insulation may, during winter, experience the warm, dry climate of the heated room in its lower part and the moist, cold climate of the unheated loft in its upper part (Figure 13 beam). The deflection  $u$  of the beam is calculated from

$$u = \frac{\kappa l^2}{8} \quad (10)$$

where  $l$  is the span of the beam and the curvature  $\kappa$  is

$$\kappa = -(\epsilon_u - \epsilon_l)/h \quad (11)$$

and  $\epsilon_u$  and  $\epsilon_l$  are the strains of the outermost upper and lower parts of the beam.

Similar examples of importance to timber engineering are for example large stressed skin roof elements or roof trusses with the lower chord placed in insulation in a relatively drier climate (Figure 13 truss).

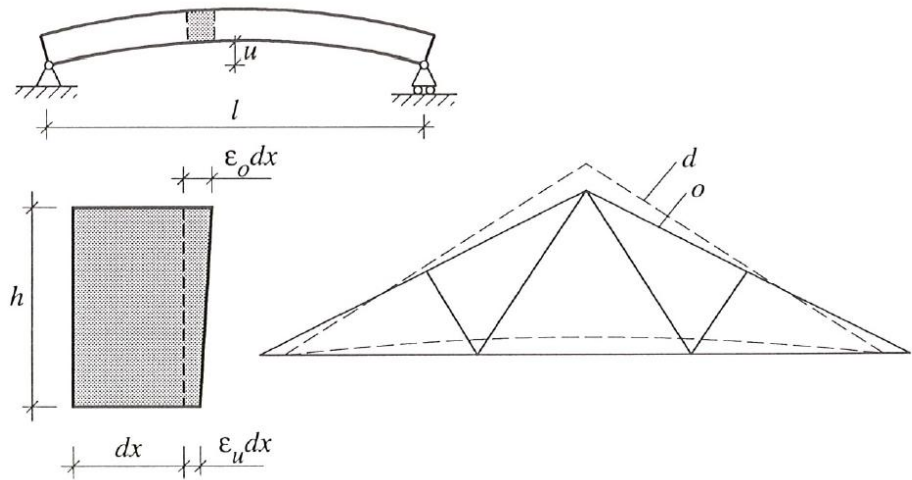

Figure 13: Structural timber elements may deflect due to uneven moisture distribution. o: original shape; d: displaced (adapted from Larsen and Riberholt, 1994).

Deflections may also occur in structures where the moisture distribution is homogeneous but different from the original moisture content. An example of such a case is given in Figure 14 which illustrates a three-hinged frame with finger jointed corners.

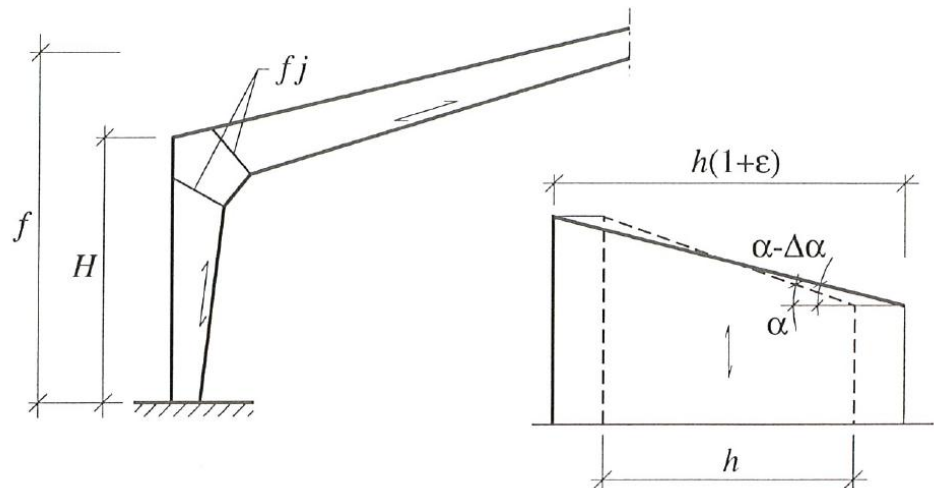

Figure 14: Homogeneous moisture change in a three-hinged frame with finger jointed corners will cause movements due to the change of the angle between fibres and the cross sections of the large finger joints (f j) (adapted from Larsen and Riberholt, 1994).

A homogenous increase in moisture content results in an increase of dimensions in the transverse direction corresponding to the moisture induced strain  $\epsilon$ . The longitudinal dimensions are assumed to stay constant. This results in a change of the angle between fibre direction and the finger joint from  $\alpha$  to  $\alpha - \Delta\alpha$  where  $\Delta\alpha$  is calculated from

$$\tan(\alpha - \Delta\alpha) = \frac{\tan \alpha}{1 + \epsilon} \quad (12)$$

The total change of angle in a two-finger-joint corner amounts to  $4 \Delta\alpha$ . In a symmetrical three-hinged frame with 2 joints in each corner the total vertical movement of the top of the frame is

$$u = 2\Delta\alpha l \tag{13}$$

In statically indeterminate structures, the above movements will give rise to increased stresses.

### Distortions

The anisotropy of transverse swelling may cause cross sections to distort upon drying (Figure 15). The fact that tangential shrinkage is about twice the radial shrinkage explains the tendency for the growth rings to straighten out.

The internal stresses developed by the anisotropic shrinkage may be released primarily in the development of radial cracks. The tendency to cracking is more pronounced the larger the cross section and the faster the drying rate.

The presence of compression wood, juvenile wood or even knots in only part of a cross section may cause lengthwise distortions known as bow, spring and twist. Twist may also result from sawing timber from a tree exhibiting spiral grain. Cup is the result of the different movements in the tangential and radial directions (Figure 16).

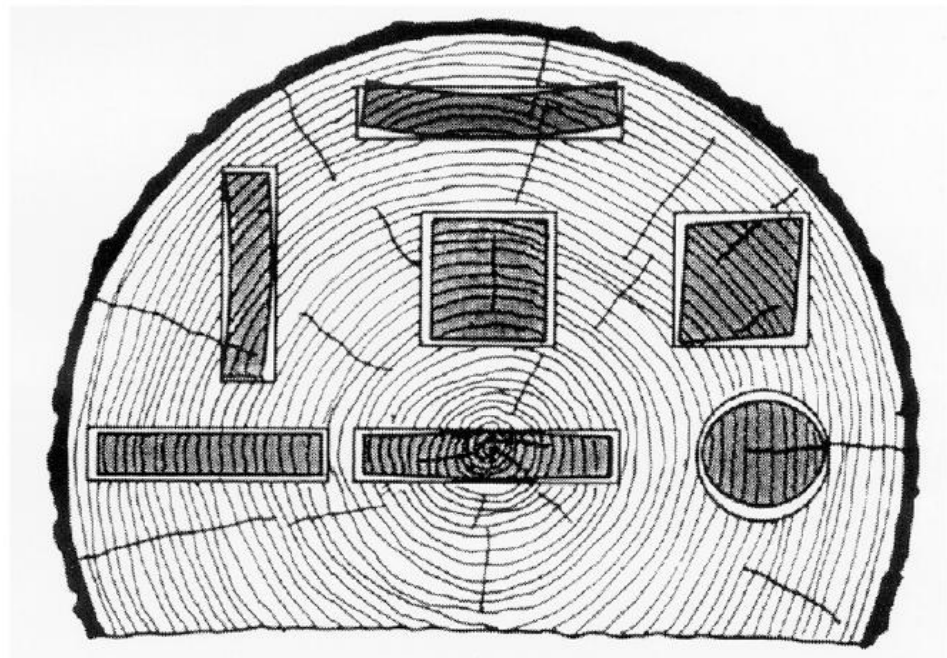

Figure 15: Distortions of various cross sections after drying, cut from different locations in a log.

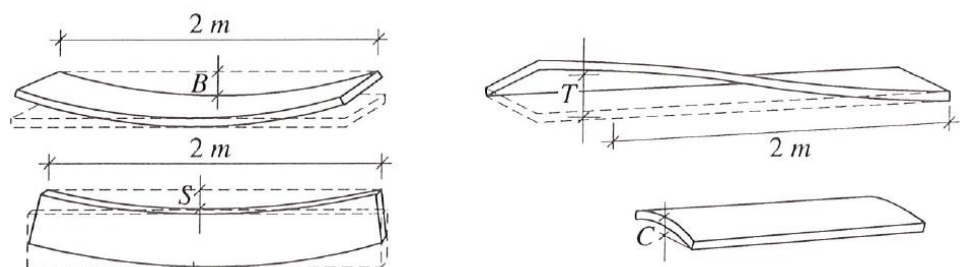

Figure 16: Distortions. B: bow; T: twist; S: spring; C: cup.

The degree of distortion is often given maximum limits in national strength grading rules. The CEN standards for visual and machine strength grading contains recommended limits to distortion (Table 1). Such limits do not reflect an exact relationship between distortion and strength but rather define limits beyond which the handling and assembling of timber in structural components becomes unacceptably complicated. There may be occasions when the structural design calls for tighter limits than given in Table 1 and such limits then must be agreed with the producer.

Type of distortion	Grade fitting into strength class	
	C18 and below	Higher classes
Bow	20	10
Spring	12	8
Twist	2 mm/25 mm width	1 mm/25 mm width
Cup	No restrictions	

Table 1: Maximum distortion (mm per 2 m length) according to EN 518 and EN 519.

### Moisture content and mechanical properties

The mechanical properties of wood are dependent on moisture content. An increase in moisture produces lower strength and elasticity values. This effect is partly explained by the cell wall swelling, whereby less cell wall material per unit area is available. More important, however, is that water, when penetrating the cell wall, weakens the hydrogen bonds responsible for holding together the cell wall. Moisture variations above fibre saturation point have no effect on mechanical properties, since such variations are related to free water in the cell lumens.

The effect of moisture change varies for different mechanical properties. For example, failure in compression parallel to grain is caused by fibre buckling where moisture sensitive hydrogen bonds play an important role and is more sensitive to moisture than tension strength which also includes rupture of covalent bonds when tearing apart the cell wall microfibrils.

Values for the effect of moisture on the mechanical properties of clear wood properties are given in Table 2. For practical purposes a linear relationship between moisture content and properties may be assumed for  $8\% < \omega < 20\%$ .

Property	Change (%)
Compression strength parallel to the grain	5
Compression strength perpendicular to the grain	5
Bending strength parallel to the grain	4
Tension strength parallel to the grain	2,5
Tension strength perpendicular to the grain	2
Shear strength parallel to the grain	3
Impact bending strength parallel to the grain	0,5
Modulus of elasticity parallel to the grain	1,5

Table 2: Approximate change (%) of clear wood properties for a one percentage change of moisture content. Basis is properties at 12% moisture content.

For some mechanical properties the influence of moisture is less significant for timber than for clear wood (Hoffmeyer 1978; Madsen 1975; Madsen et al. 1980);

tensile strength of low quality timber is virtually independent of moisture content. Figures 17 and 18 are based on results from an investigation (Hoffmeyer 1978) of 50 x 150 mm spruce (*Picea abies*), where samples of equal strength distribution were subjected to compression, tension or bending failure at each of three different moisture content levels. All figures show strength against the percentile values.

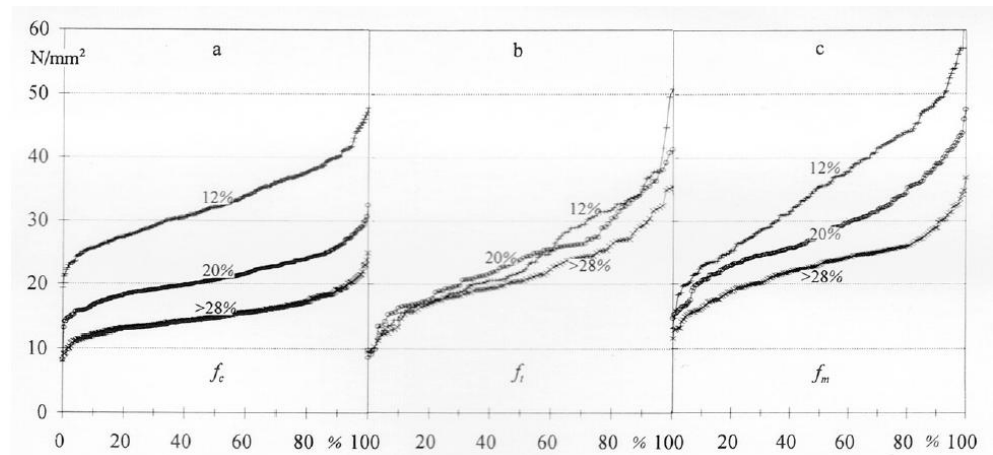

Figure 17: Strength ( $N/mm^2$ ) against percentile for matched samples of spruce (*Picea abies*) subjected to a: compression, b: tension and c: bending at moisture content levels 12%, 20% and >28%.

The influence of moisture content on compression strength is seen to be independent of timber quality, since the relative strength differences stay almost constant throughout the whole range of percentile values (Figure 17a). Tensile strength, however, seems to be very modestly influenced by moisture and no difference is seen at the 5-percentile level. In fact, dry timber strength (0–12%) drops below moist timber strength (0–20%) for the lower half of the timber quality (Figure 17b). Bending strength represents a mixture of the compression and tension behaviour, and at a timber quality level corresponding to the 5-percentile, bending strength is only very modestly influenced by moisture (Figure 17c).

Bending strength is normally higher than both compression strength and tensile strength, which is partly explained statistically by the fact that the bending test subjects only a small amount of the individual specimens to high stresses.

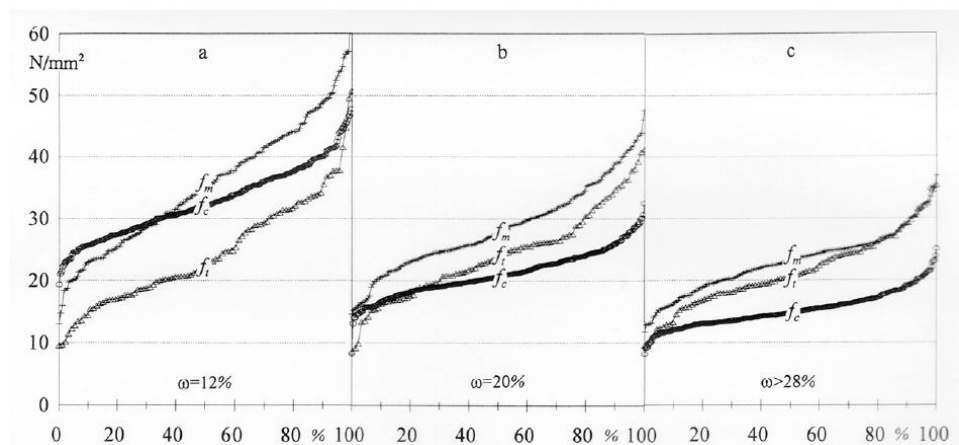

Figure 18: Strength ( $N/mm^2$ ) against percentile (%) for matched samples of spruce (*Picea abies*). The results shown in Figure 17 have been rearranged to illustrate the interrelationship of compression-, tension- and bending strength at equal moisture content levels.

The failure mode of timber subjected to bending is moisture dependent. In bending at low moisture content, failure is governed by areas of high tension, whereas at high moisture content failure is governed by areas of high compression. Tensile failures are brittle whereas compression failures exhibit extensive yield resulting in zones of compression creases.

*EN 1995-1-1:2025 5.2*

Timber subjected to the moisture conditions of service class 1 of EC5 shows higher compression strength than tensile strength for a given percentile (quality) (Figure 18a). Such timber subjected to bending will always fail in a brittle manner and linear strain distribution may be assumed all the way to failure. Timber in service class 3 condition behaves differently; here compression strength is lower than tensile strength for all quality levels (Figure 18c). Such timber will initiate bending failure by developing visible compression creases in the outermost compressed zones. As the bending stress increase, the neutral axis moves towards the tension side allowing the increased compression stresses to be carried over a larger cross section. The strain distribution is no longer linear. Eventually the tensile stress reaches the ultimate tensile strength and the beam fails. Timber in service class 2 conditions shows brittle failure for low quality beams and ductile failure, associated with compression creases, for higher quality beams (Figure 18b).

*EN 384*

When comparing mechanical properties, a standard reference moisture condition consistent with an environment of 20 °c and 65% relative humidity is to be used for timber and wood based panels. For structural timber tested at a different condition, the mechanical properties must be adjusted in accordance with prEN 384 "Structural timber - Determination of characteristic values of mechanical properties and density".

*Duration of load*

Timber experiences a significant loss of strength over a period of time. The strength values to be used in design of timber members for long-term permanent loads are approximately only 60% of the strength values found in a short-term laboratory test.

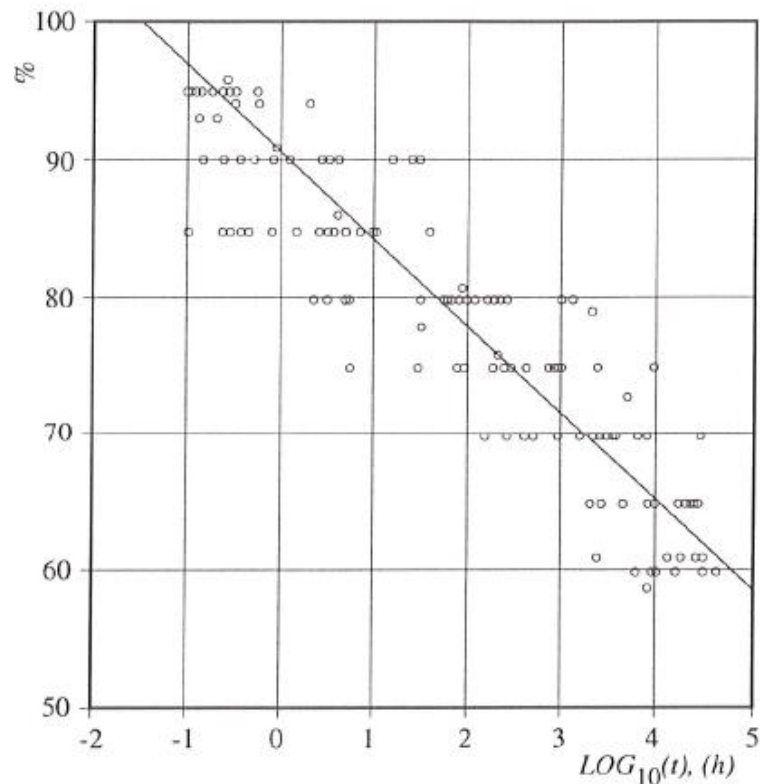

Figure 19: Stress ratio (%) as a function of logarithmic time to failure (hours) for small clear specimens subjected to bending (Wood 1951)

The background to this 0,60 modification factor dates back to the 1940's, when duration of load experiments were carried out at the Forest Products Laboratory in Madison, Wisconsin (Wood 1947, 1951). On the basis of tests on small clear specimens subjected to bending for up to seven years, a stress-lifetime relationship was established, which predicts the 10-years strength to be slightly less than 60% of the short term strength. The relationship, termed the "Madison curve", is illustrated in Figure 19 and is a plot of stress ratio against logarithmic time to failure, where stress ratio (SR) is the actual long term load over estimated short term failure load. Most countries have since included the resulting modification factors in their timber design codes. The Madison curve was regarded as being valid not only for bending, but for all strength properties, grades and species. The basis for regarding results obtained on small clear specimens as also being valid for structural timber is rather tenuous considering that the failure mechanisms are quite different taking account of, for example knots, inclined grain or fissures.

The first duration of load tests to include structural timber were initiated in 1970s in Canada, and suggested a much less severe modification of load factor for timber than for clear wood (Madsen and Barrett, 1976). The findings also suggested a timber quality dependency for the duration of load effect similar to that already found for the effect of moisture.

A large number of duration of load tests on structural timber have since been carried out both in North America and in Europe. From these it may now be concluded that, except for the early Canadian results, there is no general evidence of a much less severe duration of load modification factor for timber than for clear wood. In fact, some results (Gerhards, 1991, Soltis et al., 1989) suggest the Madison curve to be non-conservative for timber in bending. Furthermore the duration of load behaviour

of timber in tension and compression is reported to comply with the Madison curve (Glos, 1987; Lackner, 1990; Soltis et al., 1989).

Moisture content has a marked influence on the duration of load behaviour (Hoffmeyer, 1987 and 1990; Fridley et al., 1991). For a given stress ratio, beams at a higher moisture content will fail before beams at a lower moisture content. However, the drier beams will have been subjected to higher loads because their short term strength is higher.

Moisture variations are known greatly to increase creep in timber. This effect is termed mechanosorptive because it is only apparent during simultaneous mechanical stress and moisture sorption cycling. The mechanosorptive effect has been shown also to shorten the time to failure of timber (Hoffmeyer, 1990; Fridley et al., 1992).

Surface treated timber or glulam members of large volume experience relatively less moisture variation than untreated timber or small volume timber. The evidence of a mechanosorptive effect suggests that surface treated timber and large volume glulam members should be allowed a more modest duration of load modification factor.

An example of the effect of moisture on duration of load behaviour is shown in Figure 20, where results from Hoffmeyer (1990) have been updated to cover seven years of load duration.

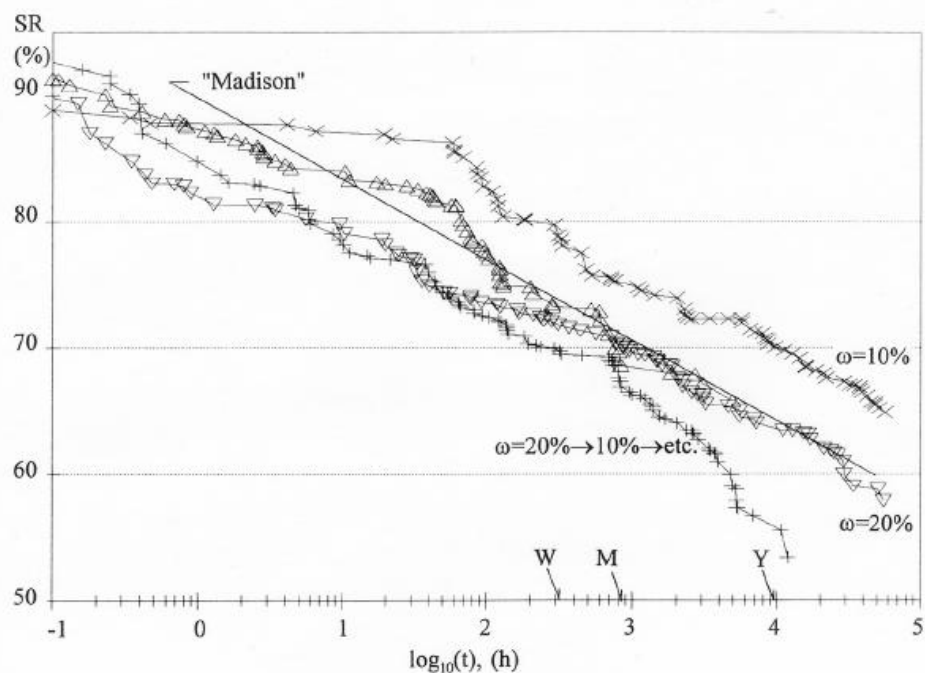

Figure 20: Stress ratio (%) against logarithmic time to failure (hours) for 50 x 100 mm beams of spruce (*Picea abies*) subjected to bending at  $\sigma = 10\%$ , ( $D = 20\%$  and at  $D$  cycling between 10% and 20%. +: varying moisture content; A: 20% moisture content; x = 10% moisture content. Y = one year. M = one month. W = one week (reproduced after Hoffmeyer, 1990).

400 beams of spruce were subjected to bending at either 10% moisture content, 20% moisture content or a moisture content varying between the two levels in a 2 monthly cycle. Matched samples were used for both short-term tests and long-term tests. All specimens of a particular sample for long-term testing were subjected to the same load and the specimens were ranked in order of ascending time to failure. The results from short-term tests on a matching sample were ranked in order of

ascending failure load. The stress ratio, SR, of a particular specimen, was then predicted as the ratio between the actual load and the failure load of the short-term specimen of the same rank and moisture content. The results show the Madison curve to describe timber at 10% moisture content conservatively, while timber at 20% moisture content is adequately modelled. A significant mechanosorptive effect is displayed under the conditions of varying moisture. The latter beams are subjected to the same loads as the beams at constant high moisture. They are therefore only at a high stress ratio during the high moisture half-cycle; during the half-cycle of low moisture they are loaded to a lower stress ratio because the corresponding short term strength increases as a result of drying. Nevertheless, the mere change of moisture content results in a significant shortening of the lifetime.

The results indicate a lifetime at the 60% stress ratio level of 0,5 year and 4 years for the beams of varying moisture content and 20% moisture content respectively. The Madison curve predicts a corresponding lifetime of five years. An extrapolation of the test results for the beams of 10% moisture content predicts a lifetime of 30 years at SR = 60%.

The duration of load behaviour of panel products varies within a very wide range. Structural plywood is considered to behave like solid wood. Particleboard behaviour is intimately linked to particle size and particle orientation, and for both particleboard and fibreboard, glue quality is of the utmost importance for the long-term properties. While the best particleboard products may be assigned a 0,40 duration of load modification factor for permanent loads, fibreboards may rate as low as 0,20.

#### *Modification factors for moisture content and duration of load*

In timber design, the influence of moisture and duration of load is taken into consideration by assigning timber structures to service classes and actions to load duration classes. EC5 then defines modification factors,  $k_{mod}$  for each combination of the two classifications.

#### *References*

Fengel, D. and Wegener, G. (1984). Wood. Walter de Gruyter.

Fridley, K.J.; Tang, R.C.; Soltis, L.A. (1991). Moisture effects on load-duration behaviour of lumber. Part I. Effect of constant relative humidity. Wood and Fiber Science 23(1):114-127.

Fridley, K.J.; Tang, R.C.; Soltis, L.A. (1992). Moisture effects on load-duration behaviour of lumber. Part II. Effect of cyclic relative humidity. Wood and Fiber Science 24(1):89-98.

Gerhards, C.C. (1991). Bending creep and load duration of Douglas-fir 2 by 4s under constant load. Wood and Fiber Science, 23(3), 1991, pp. 384-409.

Glos, P.; Heimeshoff, B.; Kelletshofer, W. (1987). Load duration effect in spruce lumber loaded in tension and compression. Holz als Roh- und Werkstoff, 45(5):243-249.

Hoffmeyer, P. (1978). Moisture Content-Strength Relationship for Spruce Lumber Subjected to Bending, Compression and Tension along the Grain. Proceedings of IUFRO Timber Engineering Conference, Vancouver, B.C., Canada.

Hoffmeyer, P. (1987). Duration of load effects for spruce timber with special reference to moisture content. Proceedings of CEC Seminar on Wood Technology, Munich, Germany.

Hoffmeyer, P. (1990). Failure of wood as influenced by moisture and duration of load. Doctoral dissertation. College of Environmental Sci. and Forestry. S.U.N.Y., Syracuse, N.Y., U.S.A.

Lackner, R. (1990). Duration-of-load Effect on Tensile Strength for Structural Softwood 45 x 145 mm. Norsk Treteknisk Institutt, Meddelelse (report) no. 76.

Larsen, H.J. and Riberholt, H. (1994). Trækonstruktioner, beregning. SBI-Anvisning 135. Statens Byggeforskningsinstitut, Denmark.

Madsen, B. (1975). Moisture Content-Strength Relationship for Lumber Subjected to Bending. Structural Research Series Report No. 11. Dept. Struct. Eng., U.B.C., Vancouver, Canada.

Madsen, B.; Barrett, J.D. (1976). Time-strength relationships for lumber. Struct. Res. Series. Report No. 13. Univ. British Columbia, Vancouver, Canada.

Madsen, B.; Janzen, W.; Zwaagstra, J. (1980). Moisture Effects in Lumber. Structural Research Series Report No. 27. Dept. Struct. Eng., U.B.C., Vancouver, Canada.

Maylan, B.A. (1968). Cause of high longitudinal shrinkage in wood. For. Prod. J. 18(4): 75-78.

Parham, R.A. and Gray, R.L. (1984). Formation and Structure of Wood. In Rowell, R.M. (ed.). The Chemistry of Solid Wood. Advances in Chemistry Series 207.

Soltis, L.A.; Nelson, W.; Hillis, J.L. (1989). Effect of loading mode on duration-of-load factors. Proceedings, Second Pacific Timber Engineering Conference. Auckland, New Zealand.

Stamm, A. (1964). Wood and cellulose science. The Ronald Press Company. N.Y., U.S.A.

Wood, L. W. (1947). Behaviour of wood under continued loading. Eng. News-Record 139(24): 108-111.

Wood, L.W. (1951). Relation of strength of wood to duration of stress. U.S. Forest Products Laboratory, Report No. 1916.