

Original by:-  
C. Short,  
Consulting Engineer

# Purlins

## Objective

To show the design, verification, and detailing of purlins in compliance with prEN 1995-1-1 DRAFT 20XX [EC5].

## Summary

Purlins from round pole, solid or glued laminated timber, and built-up sections of 'I' or Box beams are discussed. The basis of design is developed, the ultimate and serviceability limit states are identified, typical design values of actions and resulting load cases are explained.

Methods of verification or design conditions are addressed for members with biaxial actions in relation to solid timber. Durability, structural detailing, and control in relation to purlin members are discussed.

## Prerequisites

Refer to STEP lecture B3 for basic beam bending considerations and STEP lecture B4 for shear and torsion verification. Connections of various types are covered STEP articles in group C.

## Introduction

A purlin is a horizontal member in a roof supported on principal members and supporting the common rafters.

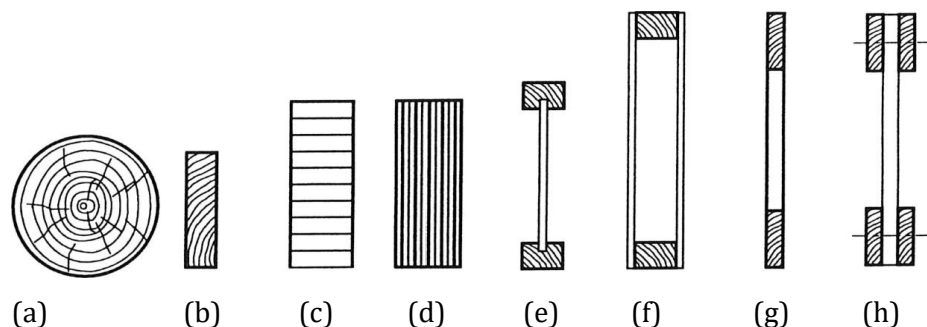

Figure 1; Examples of Purlin sections.

Figure 1 illustrates a range of typical section shapes used as purlins. (a) Round solid timber or natural timber poles, (b) solid timber sections, sometimes used in groups fixed together to act as a single unit, (c) glued laminated sections, (d) Laminated Veneer Lumber, (e) I-beams, (f) box beams, (g) trussed rafters with punched metal plate connectors, sometimes fixed together and used in groups to form a multiple truss, (h) truss with glued or nailed plywood gussets, bolted, pressed metal plate fasteners, or toothed plate connections.

Purlins can be manufactured from a variety of materials and in many configurations. The most commonly used shapes are those shown in Figure 1.

Purlins may be constructed as simply supported beams as shown in Figure 2a, or as continuous beams as shown in Figure 2b. If the timber element is continuous over three or more spans the arrangement will reduce the design moment and the effective deflection for a given section due to the continuity over the support. The limit for this structural arrangement is the maximum

continuous length which the timber can be purchased or transported to the construction site.

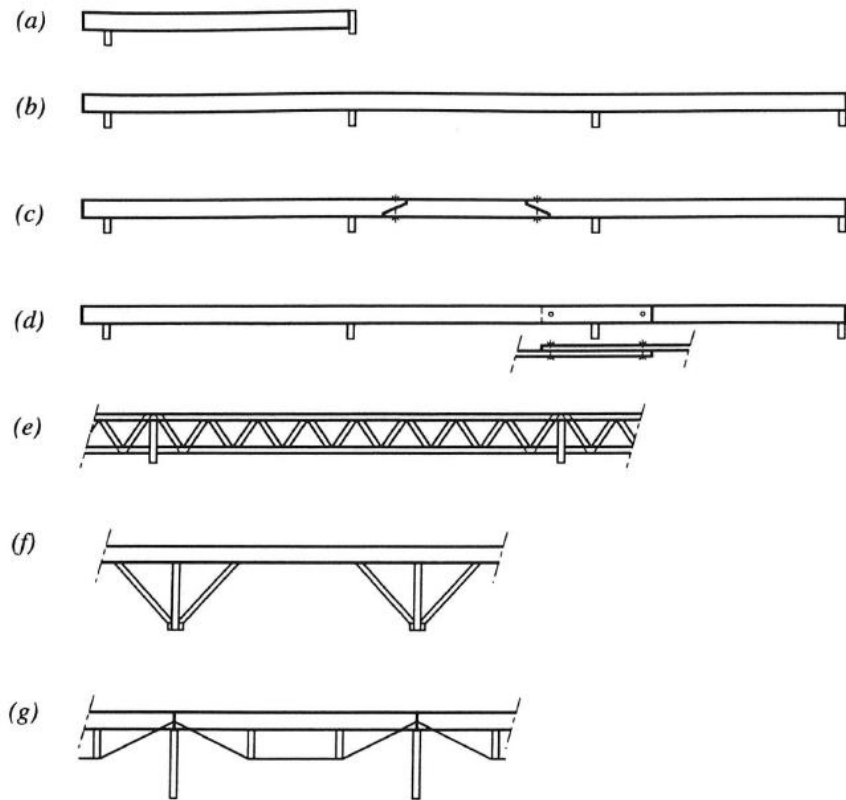

Figure 2: Typical purlin forces.

When the building length exceeds the maximum timber length one of several structural forms may be adopted to simulate the properties of the continuous beam by connecting together successive timber lengths to achieve continuity. Two methods are shown in Figure 2c and 2d. In the first case the bolted splice would occur at a point of contra-flexure and in the second case the continuity is maintained by the moment of resistance in the plated or bolted joint close to the support.

Trussed purlins, braced spans and reinforcement with tension steel are shown in Figure 2e, 2f and 2g, respectively.

## Design

In all but the simply supported span shown in Figure 2a critical points for the design would contain combined stresses from bending, shear, tension and/or compression forces. Care should be taken to evaluate the effect of the geometrical orientation of the purlin and the interaction of the force vectors which can combine to generate not only combined stresses but, in some cases, biaxial combined stress coexisting at the same point on the purlin.

The structural design method is similar to that for a simple or continuous beam except that the purlin is generally subject to biaxial bending and torsional effects. Refer to STEP lecture B3 for basic beam bending considerations and STEP lecture B4 for shear and torsion verification.

The normal loading arrangement on the purlin comes from the rafter and consists of the self weight of the rafter, the permanent load from the roof materials, transient load from snow or wind loads, and imposed load on the surface of the roof.

The imposed load is generally applied to the horizontal projected plan area of the roof whereas the snow, weight of the roof materials and the self-weight of the rafter are applied to the true area and true length respectively. These loads have a line of action which is vertical. The wind loading is applied at right angles to the true surface area of the roof as a pressure and can act in an upwards (suction) or downwards (positive pressure) direction depending on the prevailing wind direction and the geometric properties of the building being designed. The loads supported by the purlin should be determined from the structural action of the supported rafters. The loading patterns for each case shall be investigated as defined by EN 1990. In the simple example that follows, the rigorous action analysis has been omitted for brevity, but a full action appraisal would be required to suit the design criteria for each project.

### Example

Continuous purlin over 6 spans of 6 m length (see Figure 3) : -

roof slope;  $\alpha = 10^\circ$

purlin spacing;  $l_r = 1,15$  m

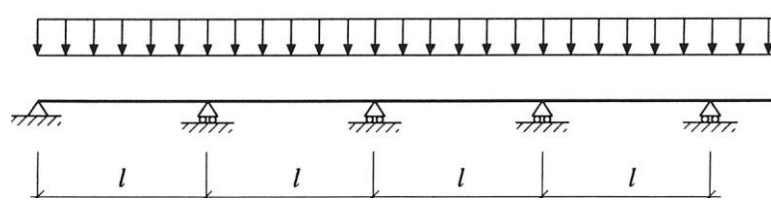

Figure 3: Example purlin.

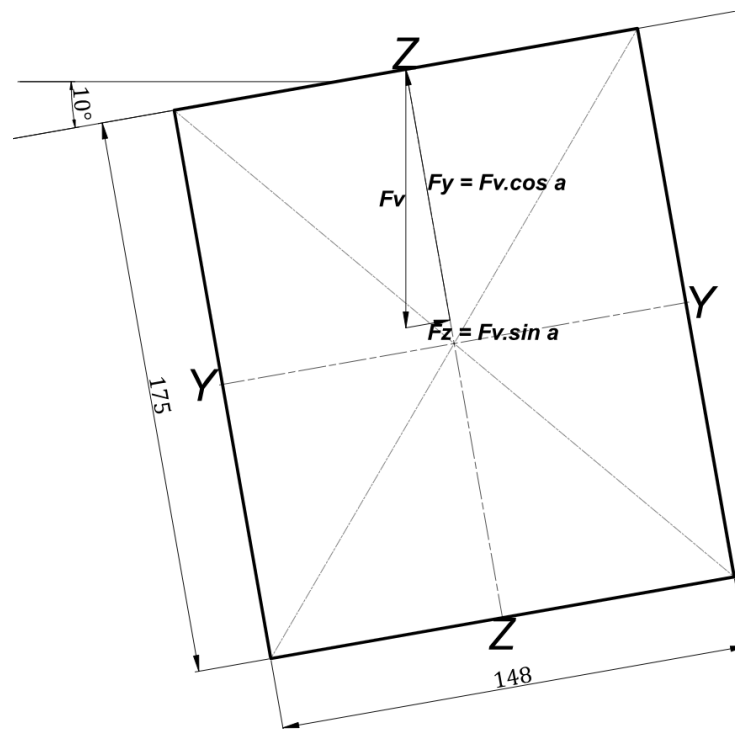

Figure 4: Purlin section configuration

Table 3.1	Roof pitch or slope; $\alpha =$	10.00	°
	Purlin spacing; $l_p =$	1,15	m
	Number of elements in member; $n =$	1.00	
	Element and section depth; $h =$	175.00	mm
	Element breadth; $b_e =$	148.00	mm
	Section breadth; $b = n b_e =$	148.00	mm
	Rectangular structural timber is classed as	ST	
	Area; $A = b h =$	19 200	mm <sup>2</sup>
	Moment of inertia for Y; $I_y = bh^3/12 =$	6,61E+07	mm <sup>4</sup>
	Moment of inertia for Z; $I_z = hb^3/12 =$	4,73E+07	mm <sup>4</sup>
Section modulus for Y; $W_y = bh^2/6 =$	7,55E+05	mm <sup>3</sup>	
Section modulus for Z; $W_z = hb^2/6 =$	6,39E+05	mm <sup>3</sup>	

*Partial safety factors*

EN 1990	Permanent actions; $\gamma_G =$	1,35
EN 1990	Variable actions; $\gamma_Q =$	1,50
Table 4.3	Material properties; $\gamma_M =$	1,3
EN 338	Timber strength class is	C24
Table 4.2	Service class is	1
Table 4.1	Load duration class is	Short-term

*Characteristic strength – EN338*

EN 338	Bending stress; $f_{m,k} =$	24	N/mm <sup>2</sup>
EN 338	Shear stress; $f_{v,k} =$	4	N/mm <sup>2</sup>
EN 338	Compression 90° to grain; $f_{c,90,k} =$	2,5	N/mm <sup>2</sup>
EN 338	Minimum modulus of elasticity; $E_{0,05} =$	7 370	N/mm <sup>2</sup>
EN 338	Min density; $\rho_k =$	350	kg/m <sup>3</sup>

*Modification factors – prEN 1995-1-1*

Table 5.1	Duration and moisture content; $k_{mod} =$	0,9	
Table 5.2	Deformation; $k_{def} =$	0,60	
█ (5.3)	Depth; $k_h = \text{Min}((h/150)^{0,2}; 1,3) =$	1,03	
█ (5.4)	$k_{h,v,z} = \text{Max}(\text{Min}((b/150)^{0,2}; 1,3); 1) =$	1,00	
(8,29)	$f_{v,k,ref} =$	2,30	
8.1.11.1(4)	$k_{var} =$	1,00	
	Design bending stress; $f_{m,d} = k_{mod} k_h f_{m,k} / \gamma_M =$	17,14	N/mm <sup>2</sup>

*Characteristic values of actions**Permanent actions (self-weight)*

Varies with the materials actually used: -

Roofing and rafters =	0,20	$kN/m^2$ (roof area)
Insulation =	0,06	$kN/m^2$ (roof area)
Ceiling =	0,10	$kN/m^2$ (roof area)
Purlins and bracing =	<u>0,10</u>	$kN/m^2$ (roof area)
$\Sigma(g_{ki}) =$	<u>0,46</u>	$kN/m^2$ (roof area)
$g_k = \Sigma(g_{ki})/\cos(\alpha) =$	0,47	$kN/m^2$ (horizontal area)

*Variable actions (snow and wind):*

Depends upon the region and the altitude of the proposed structure: -

EN 1991		Variable imposed; $q_k =$	0,75 $kN/m^2$ (horizontal area)
		Wind; $w_k =$	0,00 $kN/m^2$ (roof area)
		Snow; $s_k =$	0,00 $kN/m^2$ (roof area)

EN 1990 and EN 1991 shall be consulted for combination of partial factors on actions and allowance shall be made for the occurrence of other roofing actions such as snow, rain, and wind. Snow would be possible but wind action with such a low pitch means the pressure is suction only and not governing.

A full action analysis would be normal at this stage to account for local and national requirements; but this example considers only permanent and variable imposed loading are ruling.

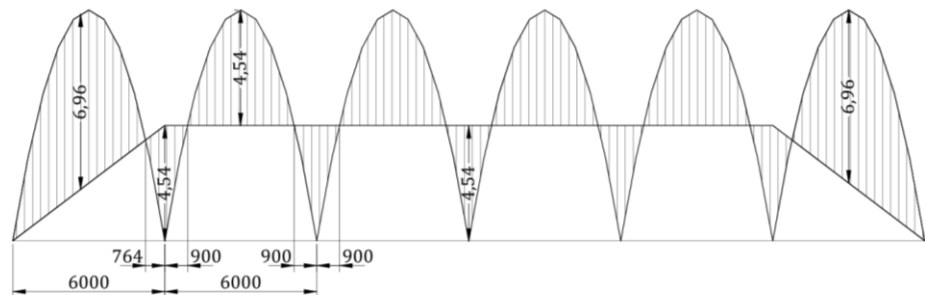

Figure 5: Typical bending moment diagram

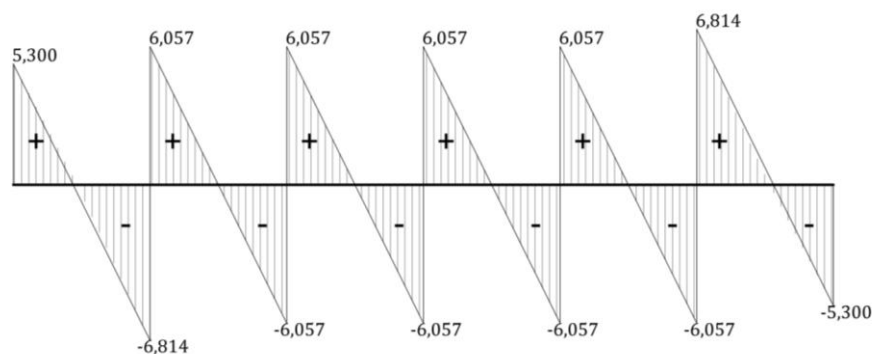

Figure 6: Typical shear force diagram

*Design values of actions*

Bay span; $l_b =$	6,00	m
Number of bays; $n_b =$	6	

A more economical solution may be achieved by making the end bay spans = 0,8535  $l_b = 5,121$ m. This would reduce the design moment to about 4,54kNm; but that could not be accomplished here.

*Vertical force from rafter to purlin.*

$F_{v,d} = l_p (\gamma_G g_k + \gamma_Q q_k) =$	2,02	kN/m
$F_{y,d} = F_{v,d} \cos \alpha =$	1,99	kN/m
$F_{z,d} = F_{v,d} \sin \alpha =$	0,35	kN/m
Max moment; $M_{max,d} =$	6,96	kNm
Min Moment; $M_{min,d} =$	-4,54	kNm
Design moment; $M_d = \max(\text{abs}(M_{max,d}); \text{abs}(M_{min,d})) =$	6,96	kNm
$M_{y,d} = M_d \cos \alpha =$	6,85	kNm
$M_{z,d} = M_d \sin \alpha =$	1,21	kNm

*Verification**Bending*

8.1.8	<u>Bending stress</u>	
	about y; $\sigma_{m,y,d} = M_{y,d}/W_y =$	9,07 N/mm <sup>2</sup>
	about z; $\sigma_{m,z,d} = M_{z,d}/W_z =$	1,89 N/mm <sup>2</sup>
8.1.8.1(2)	$k_{red}$ accounts for the unlikely event that poor material will stretch the full width of the section.	
	for rectangular sections; $k_{red} =$	0,7
█ (8.19)	$U_{m,1} = \sigma_{m,y,d}/f_{m,d} + k_{red} \sigma_{m,z,d}/f_{m,d} =$	0,61 < 1
█ (8.20)	$U_{m,2} = k_{red} \sigma_{m,y,d}/f_{m,d} + \sigma_{m,z,d}/f_{m,d} =$	0,48 < 1
	Both utilisation factors are less than 1; this makes the bending section adequate.	

Shear

8.1.11

Shear

$$\text{Max shear force; } V_{max,d} = 6,814 \text{ kN}$$

$$\text{Min shear force; } V_{min,d} = -6,814 \text{ kN}$$

$$\text{Design shear force; } V_d = \max(\text{abs}(V_{max,d}); \text{abs}(V_{min,d})) = 6,814 \text{ kN}$$

$$V_{y,d} = V_d \cos \alpha = 6,71 \text{ kN}$$

$$V_{z,d} = V_d \sin \alpha = 1,18 \text{ kN}$$

$$\text{Shear stress; } \tau_d = 3 V_d / 2 A = 0,53 \text{ N/mm}^2$$

$$\text{Shear strength; } f_{v,d} = f_{v,k} / \gamma_M = 3,08 \text{ N/mm}^2$$

$$\text{Utilisation of strength; } U_v = \tau_d / f_{v,d} = 0,17 < 1$$

$$\text{Shear stress; } \tau_{y,d} = 3 V_{y,d} / 2 A = 0,52 \text{ N/mm}^2$$

$$\text{Shear strength; } f_{v,y,d} = k_{h,v,y} f_{v,k} / \gamma_M = 3,17 \text{ N/mm}^2$$

$$\text{Shear stress; } \tau_{z,d} = 3 V_{z,d} / 2 A = 0,09 \text{ N/mm}^2$$

$$\text{Shear strength; } f_{v,z,d} = k_{h,v,z} f_{v,k} / \gamma_M = 3,08 \text{ N/mm}^2$$

$$(8.28) \quad k_{v,y} = \min(k_{h,v} k_{var} f_{v,k,ref} / f_{v,k}; 1,0) = 0,59$$

$$k_{v,z} = \min(k_{h,v,z} k_{var} f_{v,k,ref} / f_{v,k}; 1,0) = 0,58$$

$$(8.27) \quad U_v = (\tau_{v,d} / (k_{v,y} f_{v,y,d}))^2 + (\tau_{z,d} / (k_{v,z} f_{v,z,d}))^2 = 0,94 < 1$$

Utilisation factor for shear is less than 1; making the section adequate for shear forces but a check for torsion may be appropriate; refer to STEP B4 for current advice.

Bearing

8.1.6

## Bearing strength

8.1.6.1(2)

There are options available for the calculation of  $k_{c,90}$  and  $k_{mat}$ ; otherwise, the values shall be taken as 1,0 for each variable.

Table 8.1

$$\text{Shape factor; } h/b = 1,18$$

$$\text{Case selected is } B$$

$$\text{Strain} = 0,1$$

$$k_{mat} = 2,1$$

(8.8)

$$\text{Depth; } h_{ef} = \min(0,4h; 140\text{mm}) = 70 \text{ mm}$$

End supports

Fig 8.3

$$\text{End Reactions; } R_{1,7} = F_{c,90,d} = 5,30 \text{ kN}$$

$$\text{Minimum bearing length; } l_{c,90} = 0,66 \text{ mm}$$

$$\text{Spreading length; } l_{ef} = l_{c,90} + h_{ef} = 70,66 \text{ mm}$$

(8.6)

$$\text{Spreading factor; } k_{c,90} = (l_{ef} / l_{c,90})^{0,5} = 10,35$$

$$\text{Area of the applied force; } A = l_{c,90} b = 9,77\text{E}+01 \text{ mm}^2$$

(8.5)

$$\text{Bearing stress; } \sigma_{c,90,d} = F_{c,90,d} / A = 54,26 \text{ mm}$$

$$\text{Bearing strength; } f_{c,90,d} = k_{mat} k_{c,90} f_{c,90,k} = 54,32 \text{ N/mm}^2$$

(8.4)

$$U_{c,90} = \sigma_{c,90,d} / f_{c,90,d} = 1,00 \leq 1; \text{ OK}$$

Penultimate supports

	Penultimate Reactions; $R_{2-6} =$	12,87	kN
	Minimum bearing length; $l_{c,90} =$	2	mm
Fig 8.3	Spreading length; $l_{ef} = l_{c,90} + 2 h_{ef} =$	142	mm
(8.6)	Spreading factor; $k_{c,90} = (l_{ef}/l_{c,90})^{0,5} =$	8,43	
(8.5)	Area of the applied force; $A = l_{c,90} b =$	2,96E+02	mm <sup>2</sup>
(8.5)	Bearing stress; $\sigma_{c,90,d} = F_{c,90,d}/A =$	43,48	mm
	Bearing strength;	44,24	N/mm <sup>2</sup>
(8.4)	$f_{c,90,d} = k_{mat} k_{c,90} f_{c,90,k} =$		
	$U_{c,90} = \sigma_{c,90,d}/f_{c,90,d} =$	0,98	<= 1; OK

Internal supports

	Internal Reactions; $R_{3-5} =$	12,11	kN
	Minimum bearing length; $l_{c,90} =$	2	mm
Fig 8.3	Spreading length; $l_{ef} = l_{c,90} + 2 h_{ef} =$	142	mm
(8.6)	Spreading factor; $k_{c,90} = (l_{ef}/l_{c,90})^{0,5} =$	8,43	
(8.5)	Area of the applied force; $A = l_{c,90} b =$	2,96E+02	mm <sup>2</sup>
(8.5)	Bearing stress; $\sigma_{c,90,d} = F_{c,90,d}/A =$	40,92	mm
	Bearing strength; $f_{c,90,d} = k_{mat} k_{c,90} f_{c,90,k} =$	44,24	N/mm <sup>2</sup>
(8.4)	$U_{c,90} = \sigma_{c,90,d}/f_{c,90,d} =$	0,93	<= 1; OK

Deformation

EN 1990-1 Purlins in roof structures would not normally be checked for vibration sensitivity; therefore, the check here is for deflection as a serviceability limit state.

A.1.8 The purlin would be part of an inaccessible rigid roof; the plaster board ceiling and general appearance would be the ruling criteria.

Table A.1.10 (NDP)	Plastered ceiling; $w_2 + w_3 \leq l/350 =$	17,1	mm
	Appearance; $w_1 + w_2 - w_c \leq l/250 =$	24,0	mm
	Action for defection; $F_\delta = l_b l_p (g_k + q_k) =$	8,40	kN
	$F_{\delta,g,k} = F_\delta g_k / (g_k + q_k) =$	3,22	kN
	$F_{\delta,q,k} = F_\delta q_k / (g_k + q_k) =$	5,18	kN
	$k = l_b^3 / (E_{0,05} I_y) =$	0,44	mm/N
(8.29-32)	Span	End	Internal
	$d_i =$	185	384
	Precamber; $w_c =$	0	0
	Initial actions;		
	$w_1 = F_{d,g,k} k/d_i =$	7,7	3,7
-9.6	Long-term actions;		
	$w_2 = w_1 k_{def} =$	4,6	2,2
	Variable actions; $w_3 =$	12,4	6,0
	$w_{tot} = w_1 + w_2 + w_3 =$	24,8	11,9
	Plastered ceiling; $w_2 + w_3 =$	17,0	8,2
	Appearance; $w_1 + w_2 - w_c =$	12,4	6,0

## Connections

### Contraflexure points

For this example, the timber of the chosen target size and grade is only available in 4,80m lengths and the spans are 6,00m long. Splicing and material extension points are best placed at points of contra flexure, where both bending and shear actions are of a lower magnitude. Joints should not be placed at maximum moment or shear action points. Joints should be staggered on the structure; common practice is to place joints in asymmetrical locations and reverse alternate members on the structure layout. This reduces the chance of a line of weakness developing in the structural form.

On this proposal the layout has points of contra-flexure at zero moment that occur in the end bays at 764mm from the continuous support; and at the internal spans they occur 900mm from a support.

There are five types of joint that could be used in this proposal; Finger, Bolted scarf, lapped joint, metal plated splice, and dowel joint.

We have chosen the finger joint that is best made in factory conditions for the material extensions and the dowel joint would be set up in the factory but completed on site.

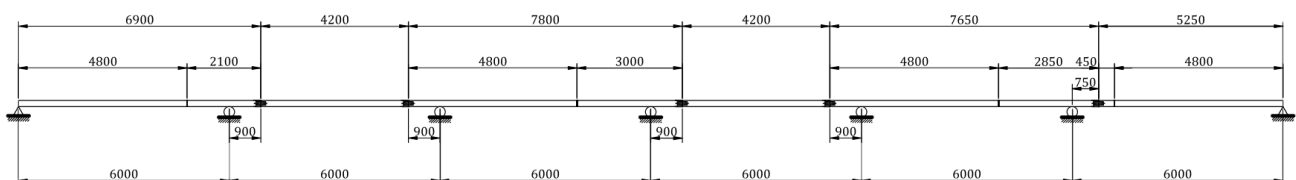

Figure 7: Support and joint positions

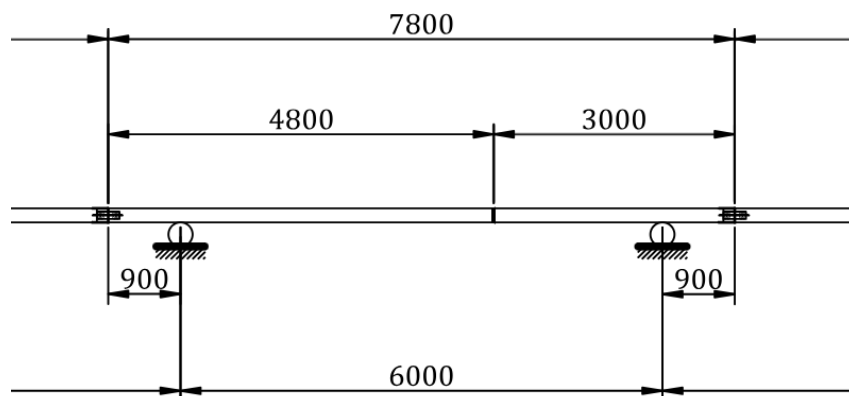

Figure 8: Enlarged centre detail

### Finger joints

Finger joints are a method of lengthening timber by joining successive pieces of similar sections of timber, end to end, with a machined finger like joint profile provided with a proven adhesive in the joint line. The finished and cured joint has been shown to have a similar strength to the base timber, so the joined timber can be treated as a homogeneous unit from end to end. In theory the 4,8-metre long C24 available to us could be made into a single unit 36 metres long, but this would of course be too long and unwieldy to handle

## STEP Article E3 - Purlins

in transit and on site. Lengths are available up to 13m long in the market place, but we have limited ourselves to unit length less than or equal to 9,6 metre. This would be equivalent to two 4,8 metre lengths joined together.

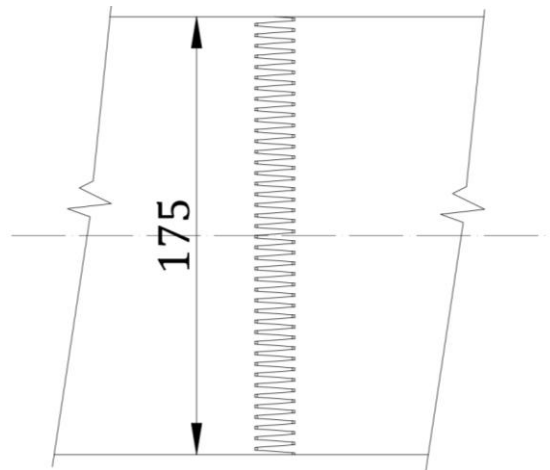

Figure 9: Typical finger joint

Some commercial outlets in the market place can produce material units of any size/length because the timber is joined on a continuous basis with cuts made to suit the material order. This reduces timber waste to a minimum.

The reference standard is EN 15497 Structural finger jointed solid timber - Performance requirements and minimum production requirement.

### Dowel joint

The dowels used to connect parts of the purlin are placed at points of contraflexure where they would be subject to mainly shear forces from the structure. We are therefore interested in the performance in lateral resistance.

The timber section is relatively small; we will try a hidden steel plate ; the connection could also be made with external metal plates bolted for end-to-end timber connection.

## Hidden plate

	Dowel diameter; $d =$	7	
	Dowel area; $A_d = \pi r^2 =$	38	
	Dowel inertia; $I_d = \pi d^4 / 64 =$	118	
	S275 steel plate; $t_2 =$	5	
	$f_{y,k} =$	275	
	$f_{u,k} =$	390	
	$t_{h1} = (b-d)/2 =$	70,5	
	Inner steel plates: $k_{pl} =$	1,00	
	$t_{h2} = t_2 / 2 =$	2,50	mm
	Embedment strength; $f_{h2,k} = k_{pl} =$	600	N/mm <sup>2</sup>
	Outer timber- predrilled holes		
	$k_{mat} =$	1	
■ (4)	$f_{h1,k} = f_{h,\alpha,\beta,k} = (0,082(1-0,01d)\rho_k) / k_{mat} =$	26,691	N/mm <sup>2</sup>
	$\beta = f_{h2,k} / f_{h1,k} =$	0,044	
Table 11.8(2)	$M_{y,k} = 0,3 f_{u,k} d^{2,6} =$	18 426	Nmm
■ (11.1)			
(a)	$f_{h1,k} t_{h1} d =$	13,17	kN
(b)	$f_{h2,k} t_{h2} d =$	10,50	kN
(c)	$f_{h1,k} t_{h1} d / (1+\beta) ((\beta+2\beta^2(1+t_{h2}/t_{h1}+(t_{h2}/t_{h1})^2)+\beta^3(t_{h2}/t_{h1})^2)^{0,5}-\beta(1+t_{h2}/t_{h1})) =$	2,20	kN
(d)	$1,05 ((f_{h1,k} t_{h1} d) / (2+\beta)) ((2\beta(1+\beta)+4\beta(2+\beta)M_{y,k}) / (f_{h1,k} d t_{h1}^2))^{0,5}-\beta =$	1,84	kN
(e)	$1,05 ((f_{h1,k} t_{h2} d) / (1+2\beta)) ((2\beta^2(1+\beta)+4\beta(1+2\beta)M_{y,k}) / (f_{h1,k} d t_{h2}^2))^{0,5}-\beta =$	0,77	kN
(f)	$1,15(2\beta/(1+\beta))^{0,5} (2 M_{y,k} f_{h1,k} d)^{0,5} =$	0,88	kN
	Dowel-effect; $F_{D,k} = \min[a;b;c;d;e;f] =$	0,77	kN
			failure mode is (e)
Table 11.10	$k_{rp,2} =$	0,00	
	Rope-effect; $F_{rp,k} =$	0	kN
-11.9	Per shear face. $F_{v,k} = F_{D,k} + F_{rp,k} =$	0,77	kN
	Number of shear faces =	2,00	
	Resistance per dowel = $n_f f_{v,k} / \gamma_M =$	1,18	kN
	Shear at points of contra flexure		
	End span; $F_v = 5,300 - f_{v,d} (lp-0,75) =$	-5,30	kN
	Internal span; $F_v = 6,057 - f_{v,d} (lp-0,9) =$	-4,24	kN
	Design connection for; $F_{v,d} = \max F_v =$	5,30	kN
	Number of dowels required; $n = F_{v,d} / (2 * F_{v,k}) =$	3,45	try 6
	$n =$	6	
	Force on each dowel; $F_v = F_{v,d} / n$	0,88	$\leq 1,18$ .

Table 11.17

<u>Spacing for Predrilled dowels</u>			
With the grain; $a_1 = 5d =$	35	mm	
Across the grain; $a_2 = 4d =$	28	mm	
Leading edge with grain; $a_{3,t} = \max(7d; 80) =$	80	mm	
Trailing edge with grain; $a_{3,c} = 7d =$	49	mm	
$a_{4,t} = 7d =$	49	mm	
$a_{4,c} = 3d =$	21	mm	

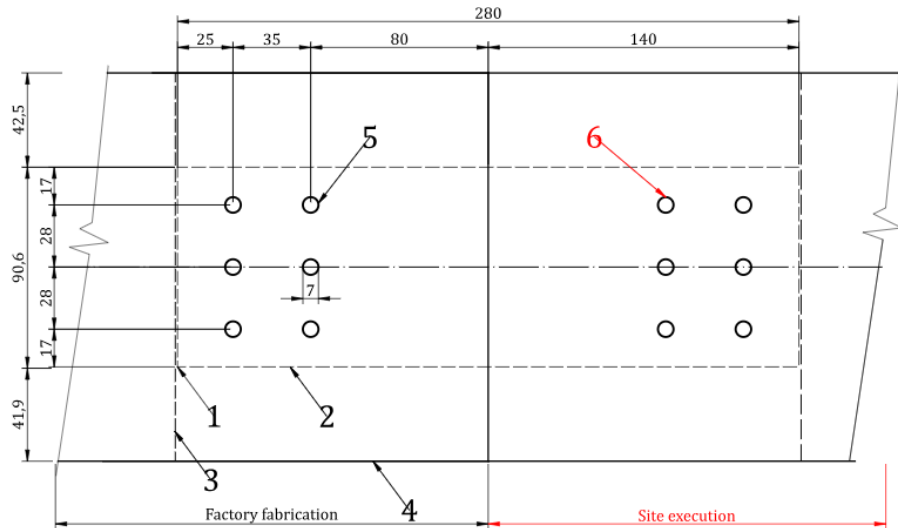

Figure 10: Dowel plate connection

1. Tolerance between steel plate and slot in timber.
2. Outline of steel plate.
3. End of saw cut slot in timber parallel to grain.
4. Edge of timber member.
5. Six dowels inserted in factory.
6. Six dowels inserted during site execution.

$$\begin{aligned} \text{Lever arm for dowel group; } l_A &= 195 \text{ mm} \\ \text{Moment from connection; } M = l_A F_{v,d} &= 1\,033 \text{ kNmm} \\ I_y = 4(I_d + A_d 28^2) + 2(I_d + A_d 0^2) &= 121\,395 \text{ mm}^4 \\ I_z = 6(I_d + A_d 35^2) &= 283\,568 \text{ mm}^4 \\ \text{Polar inertia of group; } I_p = I_y + I_z &= 404\,963 \text{ mm}^4 \\ I_G = (17,5^2 + 28^2)^{0,5} &= 33,02 \text{ mm} \\ \text{Force from moment; } F_{m,v} = M l_G / I_p &= 0,08 \text{ kN} \\ \text{Horizontal angle of } F_{m,v}; \alpha_g = \arccos(15 / l_G) &= 62,98^\circ \\ \text{Resultant force;} \\ F_R = (F_v^2 + F_{m,v}^2 + 2F_v F_{m,v} \cos(\alpha_g))^{0,5} &= 0,92 \text{ kN} \\ \text{Design is adequate - PASS } &\leq 1,18 \text{ kN} \end{aligned}$$

**Lateral torsional buckling**

A purlin in a roof system would normally be stabilised laterally by the rafters and roof covering or the ceiling finish if rigid to form a restraining diaphragm. The rafter and purlin system would normally also be stabilised by a bracing, or in some instances a rigid timber system for the sarking under the tiling battens. However, if the purlin cannot be stabilised in that way then the following check should be applied.

2<sup>nd</sup> order methods are covered in 7.4 with lateral torsional buckling in 7,4,3.

Most designers will be satisfied with 1st order methods of linear analysis, covered in 8.2 shown below:

8.2	<b>Stability of members : simplified verification</b>	
8.2.2	<b>Member buckling verifications by factors (<math>k_c - k_m</math> methods)</b>	
8.2.2.2(1)	<b>Flexural buckling</b>	
	Characteristic compressive stress; $f_{c,0,k} =$	21 N/mm <sup>2</sup>
Table D.2	Equivalent length factor [fixed - pinned]; $c_{fb} =$	0,7
	Effective length; $l = c_{fb} l_b =$	4,2 m
(D.5)	Critical force; $N_{y/z,crit} = \pi^2 (E_{0,05} I_{y/z} / l^2) =$	2,73E+05 N
	Critical stress; $\sigma_{y/z,crit} = N_{y/z,crit} / A =$	14,20 N/mm <sup>2</sup>
(8.35)	$\lambda_{c,y/z,rel} = (f_{c,0,k} / \sigma_{y/z,crit})^{0,5} =$	1,22 > 0,3 OK
	<b>(8.46) and (8.47) can be used.</b>	
8.2.2.3(1)	<b>Lateral torsional buckling</b>	
	Characteristic bending stress; $f_{m,y,k} =$	24 N/mm <sup>2</sup>
(8.47)	Critical moment; $M_{m,y,crit} = \pi / l (E_{0,05} I_z G_{0,05} I_x)^{0,5} =$	9,42E+07 Nmm
	Critical bending stress; $\sigma_{y/z,crit} = M_{m,y,crit} / W_y =$	124,64 N/mm <sup>2</sup>
(8.46)	$\lambda_{m,rel} = (f_{m,y,k} / \sigma_{m,y,crit})^{0,5} =$	0,44
(8.47)	$(\lambda_{c,z,rel}^2 + \lambda_{m,rel}^4)^{0,5} =$	1,23 > 0,3 OK
8.2.2.3(1)	<b>(8.48) and (8.49) can be used.</b>	
	$h/b =$	1,18 <= 7 OK
	Equivalent bow imperfection; $e = \varepsilon_0 = 1/400 =$	0,0025
	Equivalent twist imperfection; $\theta = \theta_0 = \varepsilon_0 l_b / h =$	0,086 radians
	$\beta_{c,y} = \varepsilon_0 \pi (3 E_{05} / f_{c,0,k})^{0,5} f_{c,0,k} / f_{m,y,k} =$	0,22
	$\beta_m = \varepsilon_0 h/b \pi / 2 (E_{05} / G_{05})^{0,5} =$	0,02
	$\beta_\theta = \theta_0 h/b =$	0,10
	$\phi_{c,y} = 0,5(1 + \beta_{c,y}(\lambda_{c,y,rel} - 0,3) + \lambda_{c,y,rel}^2) =$	1,34
	$k_{c,y} = 1 / (\phi_{c,y} + (\phi_{c,y}^2 - \lambda_{c,y,rel}^2)^{0,5}) =$	0,524
	$\phi_m = 0,5(1 + \beta_\theta + \beta_m(\lambda_{m,rel} - 0,55) + \lambda_{m,rel}^2) =$	0,65
	$h/b =$	1,18 <= 7 OK
(7.15)	Equivalent bow imperfection; $e = \varepsilon_0 = 1/400 =$	0,0025
(7.16)	Equivalent twist imperfection; $\theta = \theta_0 = \varepsilon_0 l_b / h =$	0,086 radians

		<u>Imperfection factors</u>	
Table 8.2		$\beta_{c,v} = \varepsilon_0 \pi (3 E_{05}/f_{c,0,k})^{0,5} f_{c,0,k}/f_{m,y,k} =$	0,22
		$\beta_m = \varepsilon_0 h/b \pi/2 (E_{05}/G_{05})^{0,5} =$	0,02
		$\beta_\theta = \theta_0 h/b =$	0,10
(8.42)		$\phi_{c,v} = 0,5(1 + \beta_{c,v}(\lambda_{c,v,rel} - 0,3) + \lambda_{c,v,rel}^2) =$	1,34
(8.41)		$k_{c,v} = 1/(\phi_{c,v} + (\phi_{c,v}^2 - \lambda_{c,v,rel}^2)^{0,5}) =$	0,524
(8.51)		$\phi_m = 0,5(1 + \beta_\theta + \beta_m(\lambda_{m,rel} - 0,55) + \lambda_{m,rel}^2) =$	0,65
(8.5)		$k_m = 1/(\phi_m + (\phi_m^2 - \lambda_{m,rel}^2)^{0,5}) =$	0,893
(8.49)	There is no direct tensile force on this member therefore (8.49) is not relevant in this case.		
		$\sigma_{c,0,d} =$	0,00 N/mm <sup>2</sup>
(8.48)		$\sigma_{c,0,d}/(k_{c,z} f_{c,0,d}) + \sigma_{m,y,d}/(k_m f_{m,y,d}) =$	0,59 <= 1 OK
<b><u>Design is adequate - PASS</u></b>			