

CK-5001T Metropolis Patterson Transmission Crankset Installation Instructions

Published – May, 2015. ZSP001.v4 © Full Speed Ahead

Introduction

Congratulations on your Full Speed Ahead product. Please read these instructions and follow them for correct use. Failure to follow the warnings and instructions could result in damage to product not covered under warranty, damage to bicycle; or cause an accident resulting in injury or death. Since specific tools and experience are necessary for proper installation, it is recommended that the product be installed by a qualified bicycle technician. FSA & Vision assumes no responsibility for damages or injury related to improperly installed.

Warranty

Full Speed Ahead (FSA) warrants all FSA, Gravity, Vision, Metropolis and RPM products to be free from defects in materials or workmanship for a period of two years after original purchase unless otherwise stated in the full warranty policy. The warranty is non-transferable and valid to the original purchaser of the product only. Any attempt to modify the product in any way such as drilling, grinding, and painting will void the warranty. For more information on warranty policy and instructions for completing a warranty claim, check out the Full Warranty Policy found at our website: <http://www.fullspeedahead.com/techdoc>

Specification

Item Number / Model Name CK-5001T / Metropolis Patterson Transmission Crankset

Components

Follow the assembly order in the illustration:

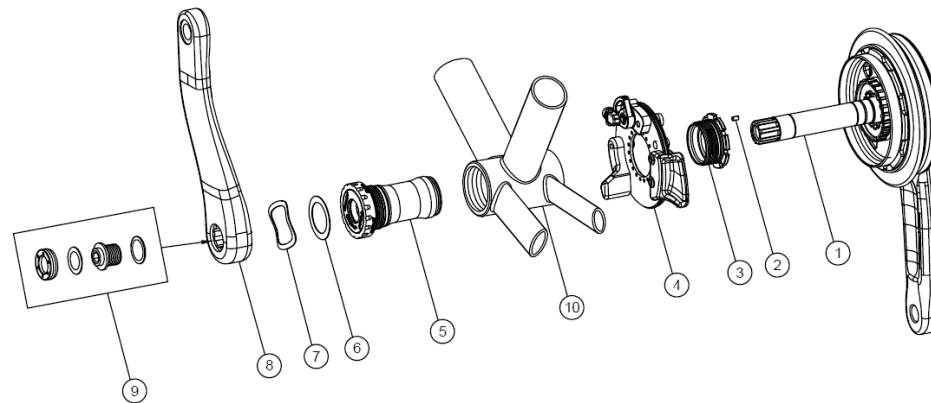

- ① Drive side crankset
- ② Set screw
- ③ Drive side BB cup
- ④ Control plate sub-assembly
- ⑤ Non-drive side BB cup with water proof sleeve
- ⑥ Seal washer (MS319)
- ⑦ MW329 wave spring washer
- ⑧ Non-drive side crankarm
- ⑨ Crank bolt
- ⑩ BB shell (68mm BSA1.37"x24T)

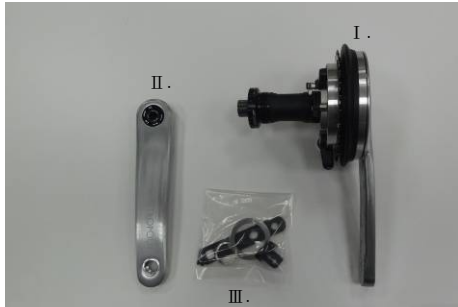

Each assembly package should include:

- I. Drive side crankset x1
- II. Non-drive side crank arm x1
- III. Accessory pack x1



Before installation, disassemble CK-5001T into below units:

- ① Drive side (Right) crankset
- ② Non-drive side (Left) crank arm
- ③ Drive-side (Right) BB cup
- ④ Non-drive side (Left) BB cup with waterproof sleeve
- ⑤ Control plate sub-assembly



Step 1: The first step of assembly involves Control plate sub-assembly ⑤ Drive side (Right) BB cup ③ and the seal washer (included in the accessory pack " D. ").

Before assembly, ensure that the parts and bottom bracket shell are clean, and free of any debris or machine chips. Make sure Bottom bracket shell is faced to exactly 68mm width. Patterson Transmission cranksets are not compatible with 73mm or Italian threaded bottom brackets.

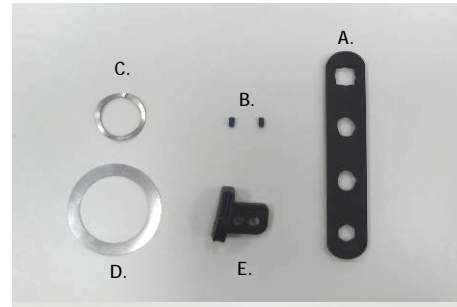

Accessory pack includes:

- A. Auxiliary tool x1
- B. Set screw x2
- C. MW329 Wave Spring Washer x1
- D. Seal washer x1
- E. Tall cable guide x1

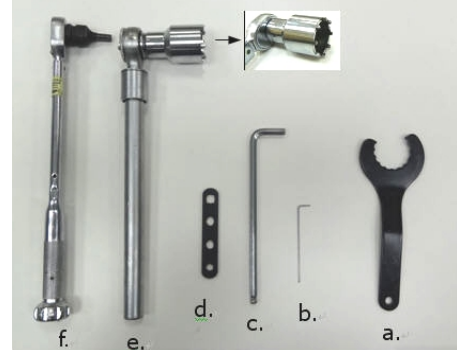

Tools for installation:

- a. Wrench for external BB
- b. 1.5mm hex wrench
- c. 8mm hex wrench
- d. Auxiliary tool (included in the accessory pack)
- e. Socket eight-notch BB wrench
- f. 8mm Torque wrench

Note: A 3/8" socket wrench can be used instead of the 8mm hex wrench " c. ".



Step 2: Place the Drive side (Right) BB cup ③ through the Control plate sub-assembly ⑤ and the seal washer " D. " as shown in the photo. Thread the BB cup ③ into the right side of the BB shell.

Keep the black Inboard chain guard in the top (12 o'clock) position.

The " D. " seal washer goes behind the Control Plate Sub assembly, over the BB cup threads. Be careful not to damage the seal washer while threading BB cup into frame.

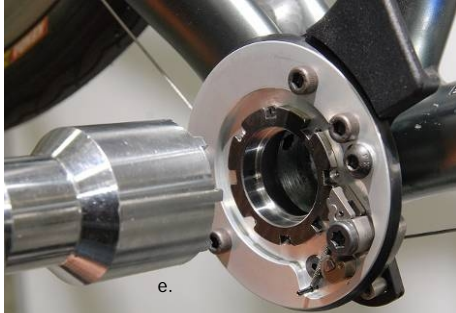

Step 3: Use the " e. " Socket eight-notch BB wrench to thread the Drive side (Right) BB cup ③ completely into the BB shell. Use very little torque. DO NOT fully tighten.

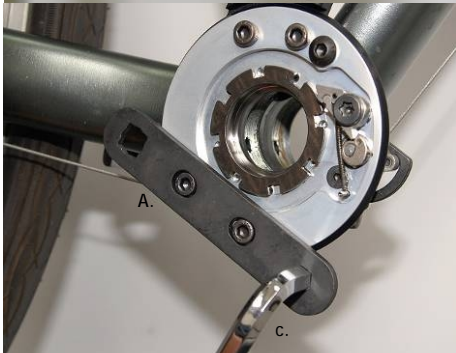

Step 5: Place the Auxiliary tool " A. " on the Control plate sub-assembly with the two holes engaging the bottom bolts, as shown in the photo. Insert the 8mm hex wrench " c. " in the hex end hole of the Auxiliary tool. These tools will fix the assembly in place during the next step of assembly.

Note: With the square hole on the other end of the auxiliary tool, the " c. " 8mm hex wrench can be replaced by a 3/8" square driver.

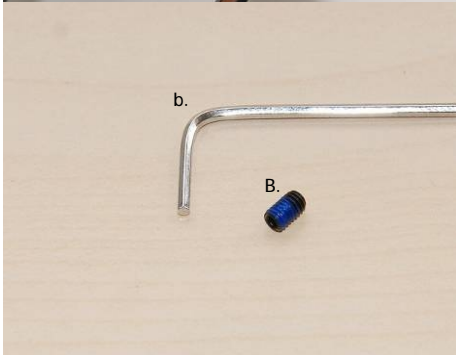

Step 7: Locate the 1.5mm hex wrench " b. " and one of the set screws " B. ". The set screw is used to keep the drive side BB cup from loosening.



Step 4: Rotate the Control plate sub-assembly ⑤ until the torque fix feature rests firmly against the bottom of the chain stay. (Circled in picture).

Note: If the rear shift cable will contacts the torque fix feature, replace the original cable guide (under the BB shell) with the Tall cable guide " E. " (included in the accessory pack).



Step 6: Turn the " c. " Hex wrench clockwise to keep the torque fix feature firmly against the chainstay. While holding the " c. " 8mm Hex wrench, turn the Socket eight-notch BB wrench " e. " counter-clockwise to tighten the Drive Side BB cup to a torque value of 408-510 kgf.cm / 40-50 Nm / 354-442 in.lbs.

Note: When BB cup is fully torqued, make sure torque fix feature is resting against the chainstay as shown in the circle in picture of step 4.

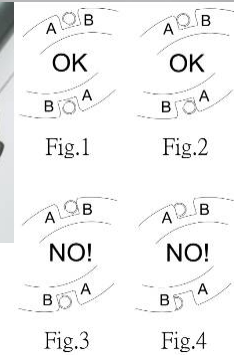
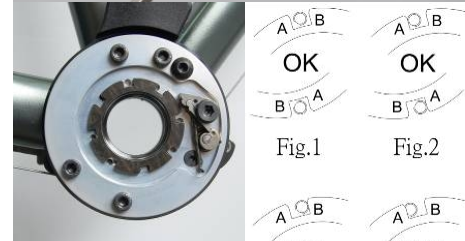

Step 8: Find a proper screw hole in the Control Plate sub assembly that is exposed between the notches in the Drive side BB cup flange. The threaded hole should be at the center of a BB cup flange notch (Fig.1) or the " counterclockwise side " of screw hole should be close to the BB cup flange notch (Fig.2, side A). DO NOT use " clockwise side ". of screw hole close to the BB cup flange notch (Fig.3, Side B), or a partially covered screw hole (Fig.4). This is important to isolate the control plate from movement.

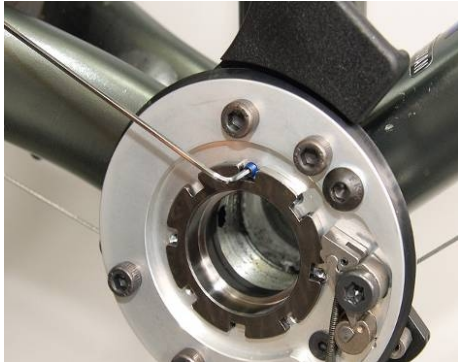

Step 9: Tighten the set screw " B. " with 1.5mm hex wrench " b. " to a torque value of 2 kgf.cm / 0.2 Nm / 1.8 in.lbs. Only one set screw is needed for assembly. The extra set screw is included as a spare.



Step 11: Use a finger to move the cable arm (at the back of Control plate sub-assembly) to full forward position, and hold until step 12 is completed.



Step 13: Release the cable arm.



Step 10: Install the Non drive side (Left) BB cup with waterproof sleeve ④. Use the an external bottom bracket wrench " a " to tighten it to a torque value of 408-510 kgf.cm / 40-50 Nm / 354-442 in.lbs.



Step 12: Install Drive side (Right) crankarm ① by sliding the spindle through the drive side (right) BB cup, through the BB shell, and out the Non-Drive side (left) BB cup.

Note: If the cable arm is not moved to the forwardmost position, the cable arm will not insert into the bottom bracket fully.

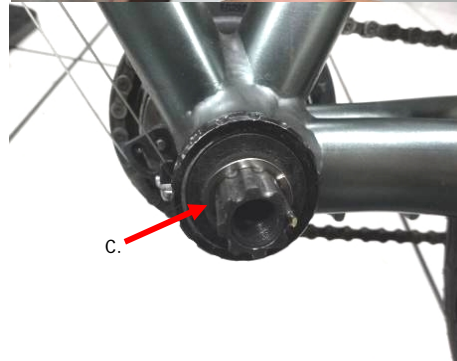

Step 14: Insert the drive side (right) crank arm and spindle ① through the both BB cups. Position the wave spring washer " C. " WM329 on the spindle on non-drive side. (as shown in photo) Apply a layer of grease on the spindle.



Step 15: Use the 8mm Torque wrench " f. " to tighten the crank bolts (Self-extracting crank bolt assembly and preload nut are pre-installed from factory.) of the Non-drive side (Left) crank arm ② to a torque value of 380-410 kgf.cm / 38-41Nm / 337-363 in.lbs

⚠ CAUTION Do not tighten M12 crank bolt over 410 kgf.cm / 41 Nm / 363 in.lbs torque. Do not completely flatten the wave spring washer. Clearance between non-drive arm and Bearing Shield should be 1.5-2.2mm. If the clearance is not within 1.5-2.2mm after applying correct torque, DO NOT tighten the crank bolt further.



Step 17: Thread the cable down to the cable arm, and install it through the cable pinch plate. Tighten the cable pinch bolt with 5mm hex wrench to a torque value of 50-70 kgf.cm / 5-7 Nm / 45-62 in.lbs.

⚠ WARNING Do not over tighten! Over tightening the cable pinch bolt can damage the bolt or cause the cable arm to brake which is not covered under warranty!



Step 19: Ensure the shift lever can be easily operated between two lowest gear positions (#1 & #2 on most gear indicators).

Note: The CK-5001T only has two gears. This means that for MTB 3 speed front shifters, the highest gear position has no function and will not be used. Do not try to force the shifter into the 3rd gear position when shifter and crankset is adjusted properly.



Step 16: Screw the front shifter barrel adjuster completely inward to reserve the adjustment range as much as possible. Check the shifter is at the lowest position possible. Usually #1 on most gear indicators.

Note: It is strongly recommended to use a shifter without " trim " functions. Trim functions are smaller clicks between gears to adjust derailleur for chain angle. Many twist style shifters have " trim " functions whereas most thumb style shifters do not.

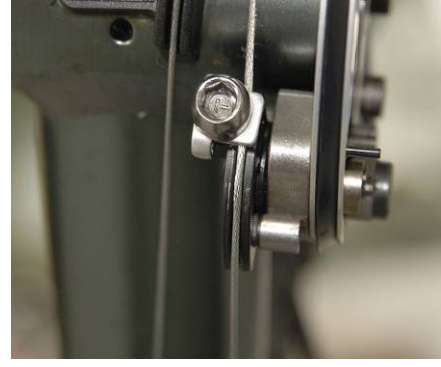

Step 18: Ensure that the shifter cable is seated in the groove of the cable arm, and fixed tightly. Loosen cable pinch bolt and re-tighten if shifter cable is not seated in the groove.



Step 20: Spin the crankset in normal direction and operating the shifter to check if the whole system works properly.



Step 21: Check shifting function while spinning the crankset. If there is a clattering noise during the upshift or in the second gear position, screw the barrel adjuster on the shifter outwards while continuously spinning the crankset until the noise disappears.



Step 22: Install the chain and pedals on the crankset. Follow pedal manufacturer's instructions.

Note: Right and Left pedal threads are opposite. Do not attempt to install Right pedal in Left crank arm or vice versa.



Step 23: Installation complete.

If you have any question about installation, please feel free to call FSA.

US Patent Number is: 7,874,955
other Patents pending



Contact

If you have questions, please visit our web site technical section: <http://www.fullspeedahead.com/contact> or contact:

Full Speed Ahead, USA
12212 Cyrus Way Mukilteo, WA 98275-5702
Tel: 1_425_488_8653 Fax: 1_425_489_1082

Full Speed Ahead, Europe
Via Del Lavoro, 56 20874 Busnago, Milan, Italy
Tel: +39_039_688_5265 Fax: +39_039_682_3336

TH INDUSTRIES / FSA Asia
NO.6, Wu-gong 8th Rd., Wufeng Dist., Taichung City 41353, Taiwan (R.O.C.)
Tel: +886_4_2331_9134 Fax: +886_4_2331_9314

Notes: Specifications of product may be changed or improved for performance. Please refer to website periodically for technical updates and revised instructions. Printed in Taiwan.

