

EWD

DIRECT DRIVEN EXHAUST FAN

EWD exhaust fan is available in 26", 31" and 37". The direct drive ensures a greater efficiency by reducing energy losses. The patented centrifugal opening system guarantees a complete shutter opening already at 40% of the nominal rotation speed.

Thanks to the completely redesigned opening system of EWD fans, the noise level has been reduced and the fan efficiency has been increased. The wallhousing is available in galvanized or stainless steel (Aeternum 31" only) for the maximum corrosion resistance.



Models 26 and 37

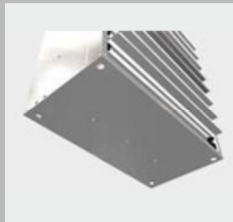

Bottom panel with 4 practical water discharge holes

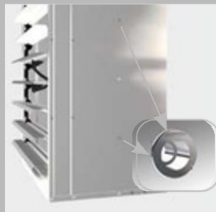

Fixing threaded bush (M8)



Technical features



EWD 26 - 31 - 37 test number Bess Lab: 16508; 16509; 16504; 16505; 16502; 16503

Model	Voltage*	Frequency	Propeller rotation speed (0 Pa - 0 inH ₂ O)	Air flow				Absorbed power (0 Pa - 0 in H ₂ O)	Absorbed power (25 Pa - 0.10 inH ₂ O)	Specific power input (0 Pa - 0 inH ₂ O)	Specific power input (25 Pa - 0.10 inH ₂ O)	Ventilating Efficiency Ratio (0 Pa - 0 inH ₂ O)	Ventilating Efficiency Ratio (25 Pa - 0.10 inH ₂ O)
				0 Pa 0 inH ₂ O	12 Pa 0.05 inH ₂ O	25 Pa 0.10 inH ₂ O	50 Pa 0.20 inH ₂ O						
EWD 26/0,5	Δ 220-240 V Y 380-420 V	50 Hz	942 RPM	5640 cfm	5450 cfm	5250 cfm	4780 cfm	429 W	467 W	45,0 W/(1000m ³ /h)	52,0 W/(1000m ³ /h)	13,1 cfm/W	11,2 cfm/W
				9600 m ³ /h	9300 m ³ /h	8900 m ³ /h	8100 m ³ /h						
	Δ 220-270 V Y 380-460 V	60 Hz	1123 RPM	5650 cfm	5440 cfm	5250 cfm	4810 cfm	419 W	457 W	44,0 W/(1000m ³ /h)	51,0 W/(1000m ³ /h)	13,5 cfm/W	11,5 cfm/W
				9600 m ³ /h	9200 m ³ /h	8900 m ³ /h	8200 m ³ /h						
EWD 31/0,75	Δ 220-240 V Y 380-420 V	50 Hz	935 RPM	9080 cfm	8760 cfm	8400 cfm	7710 cfm	645 W	695 W	42,0 W/(1000m ³ /h)	49,0 W/(1000m ³ /h)	14,1 cfm/W	12,1 cfm/W
				15400 m ³ /h	14900 m ³ /h	14300 m ³ /h	13100 m ³ /h						
	Δ 220-270 V Y 380-460 V	60 Hz	1115 RPM	8870 cfm	8510 cfm	8200 cfm	7540 cfm	643 W	692 W	43,0 W/(1000m ³ /h)	50,0 W/(1000m ³ /h)	13,8 cfm/W	11,9 cfm/W
				15100 m ³ /h	14500 m ³ /h	13900 m ³ /h	12800 m ³ /h						
EWD 37/0,75	Δ 220-240 V Y 380-420 V	50 Hz	935 RPM	10720 cfm	10240 cfm	9720 cfm	8650 cfm	633 W	693 W	35,0 W/(1000m ³ /h)	42,0 W/(1000m ³ /h)	16,9 cfm/W	14,0 cfm/W
				18200 m ³ /h	17400 m ³ /h	16500 m ³ /h	14700 m ³ /h						
	Δ 220-270 V Y 380-460 V	60 Hz	1109 RPM	11600 cfm	10960 cfm	10260 cfm	8870 cfm	680 W	730 W	35,0 W/(1000m ³ /h)	42,0 W/(1000m ³ /h)	17,1 cfm/W	14,0 cfm/W
				19700 m ³ /h	18600 m ³ /h	17400 m ³ /h	15100 m ³ /h						

Tested according to ANSI/AMCA 210-07 ANSI/ASHRAE 51-07 complying with ASABE/S565 OCT 2005.

*Single phase motors, different voltage and speed regulable motors over transformers are available on request only on EWD 26.

Note: All fans tested with shutter and protection net.



Dimensions and loading possibilities

Dimensions	EWD 26	EWD 31	EWD 37
Dimension - A - [mm]	790	905	1025
Dimension - B - [mm]	790	907	1025
Dimension - C - [mm]	530	563	563
Dimension - D - [mm]	645	678	678
Dimension - E - [Ø mm]	638	780	930
Dimension - F - [mm]	241,5	252,5	226,5
Dimension - G - [mm]	203	225	255
Dimension - H - [mm]	380	455	513
Sound pressure level Lpa* [dB]	69	74,7	81,9
Gross weight [kg]	41	48	53

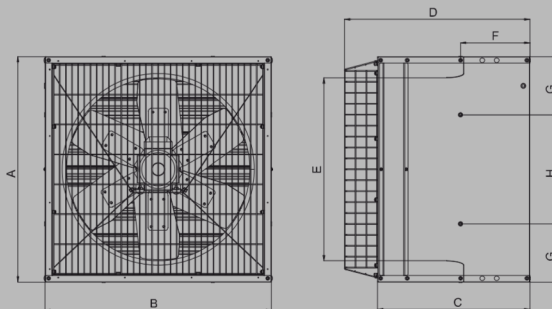

*Measurement surface according to UNI EN ISO 3744 pic C.7

Loading possibilities on pallet	EWD 26		EWD 31		EWD 37	
Fully assembled version (FA)	Type A	Type B	Type A	Type A	Type A	Type A
LxWxH [mm]	800x800x1750	800x1060x2230	910x1130x1950	910x1130x1950	1030x1140x2180	1030x1140x2180
N° pieces	3	5	4	4	4	4
Gross weight - kg	131	212	190	190	230	230

Loading possibilities

	Fully assembled version (FA)				Knock-down version (KD)		
	EWD 26	EWD 31	EWD 37		EWD 26	EWD 31	EWD 37
Container 20ft	70	48	40	Container 20ft	300	280	250
Container 40ft	150	104	88	Container 40ft	600	560	450
Container 40ft HC	180	130	92	Truck	600	600	500
Camion STD / Camion H 2,60	190 / 228	116 / 144	104				



electrical
contractor

ventilation &
Environmental

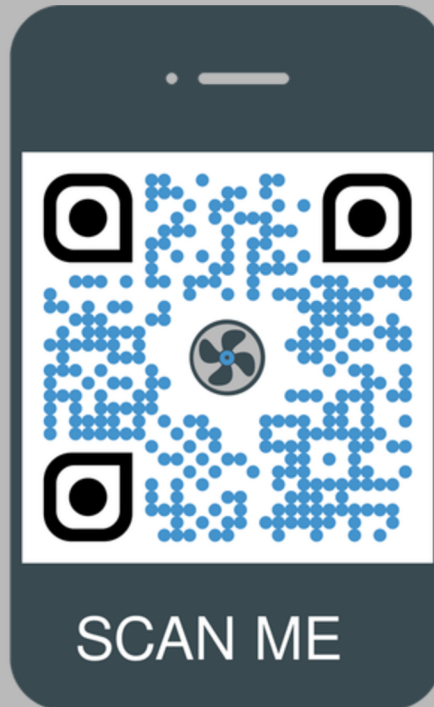

 01980 671053

 info@1803ltd.co.uk

 www.1803ltd.co.uk