

Factory Works USA-1 Cantilever Set

Requirements: Tie rods from bellcrank to suspension (4). Traxxas 1942 works well.

Start by removing the shocks and shock towers from your front and rear gearboxes. Remove the wheels and tires.

1) Left side- Carefully trim the post from the bellcrank using a sharp knife- SEE PIC. Insert one of the 8-32 screws through the new tower and hold in place with a plain nut. You want this to be tight. Now, install the pivot post. This should just be finger tight. Install a bearing, bellcrank, bearing, and follow with the nylon nut. This assembly should move smoothly without binding.

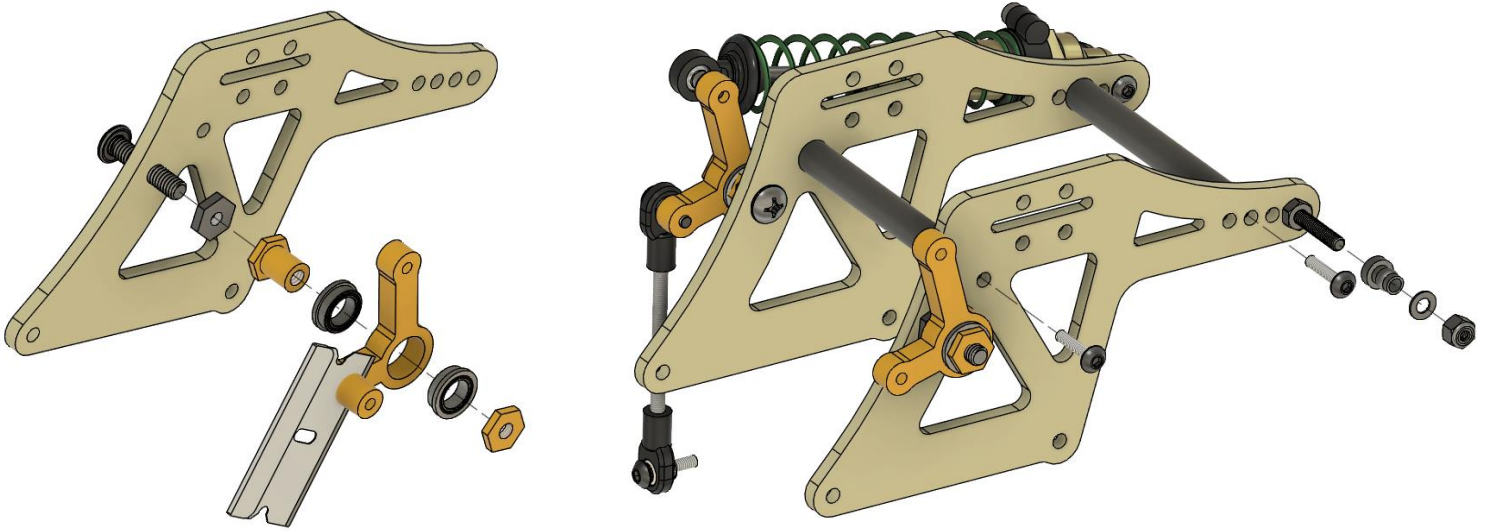

2) Install the included shock mount screw and plain nut per the shock you will be using. A 4" shock will use the furthest set of holes as shown. Shorter shocks can use the other holes as needed. Make the right side by mirroring what you have just built.

3) Install the 60mm posts between the left and right sides as shown. If you are obstructing the hole at the shock mount due to shorter shocks just use one of the other sets of holes for the post. Install your stock body mounts at this point as well, reuse stock hardware.

4) The shock can now be installed, as well as the links to the suspension. These will need to be approximately 50mm from the centers of the ball joints. Transfer the completed assembly to the vehicle using the stock screws for the shock towers. Install the screw from the link to the upper suspension arm where the stock shock was previously mounted.

