

THE NEW PATH OF LEAST RESISTANCE!™

WIRE WIZARD WELDING PRODUCTS GUIDE MODULE SYSTEM

WIRE WIZARD WELDING PRODUCTS GUIDE MODULE SYSTEM

成功案例

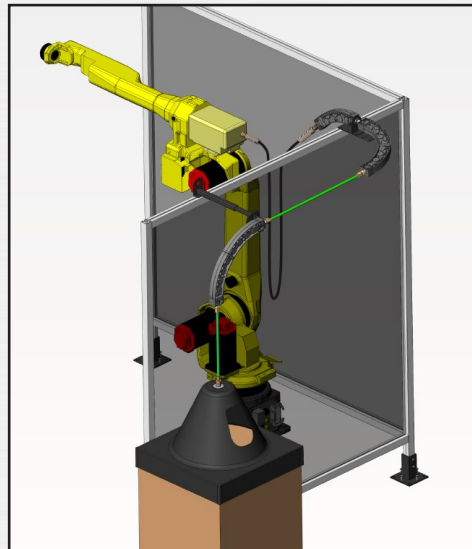

安装在工作站

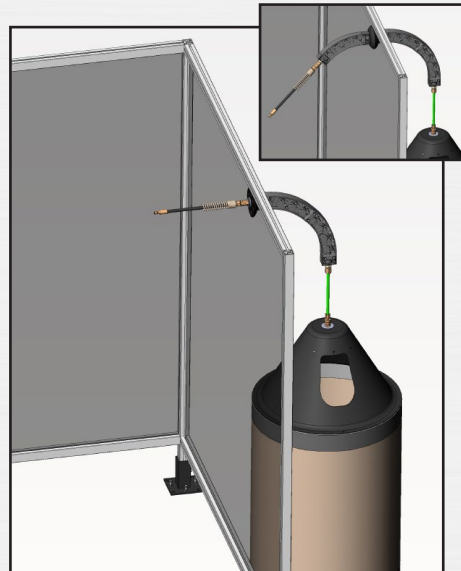

工作墙上安装模块, 节约空间



180° 模块安装在带有两个机器人 & Non-Stop™ 送丝系统

导向模块组装



导向模块组装工具箱

包含必须的安装, 测试和导丝管送到送丝机的所有工具

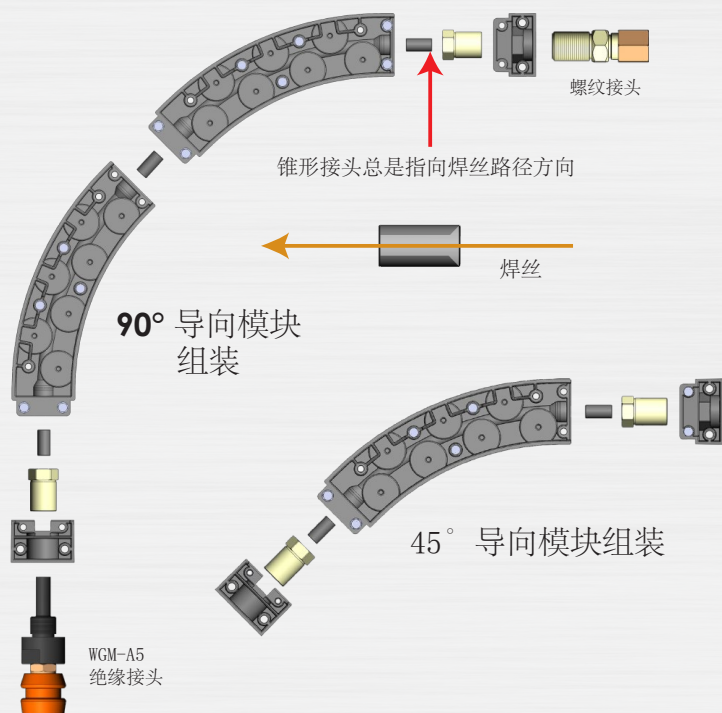

SCAN FOR PDF

组成 & 配件



THE NEW PATH OF LEAST RESISTANCE!™

创新的 Wire Wizard® Guide Module™ 采用一系列的轴承滚轮减少了焊丝在弯曲处和拐角处的摩擦, 从而使送丝更容易。通过降低摩擦, 也减少了断弧现象, 提高了焊接的一致性, 并且可以使用100feet 或更长的导丝管。可以使用45° 导向模块改装为90°, 135° 或180° 送丝系统。铁素体和非铁素体焊丝均可用。美国制造 · 专利申请中

产品特点 & 优势

- ▶ 减少焊丝在弯曲或拐角处的滑动摩擦
- ▶ 导向模块可以将送丝机的送丝阻力从磅降低到盎司。
- ▶ 通过降低摩擦延长了焊丝寿命
- ▶ 光滑, 低摩擦的送丝可以提高焊缝的一致性, 减少断弧现象和停工时间
- ▶ 适合长导丝管应用 (30.5m+)
- ▶ 可安装于桶盖, 焊接工作站; 适用于桶, 箱或木制盘装
- ▶ 节约空间, 适用于焊丝包装离工作站非常近的焊接环境

▶ 四种模块类型几乎覆盖了所有的焊接应用环境:

标准导向模块: 0.9 - 2mm 实心焊丝

90° 迷你导向模块: <1.3mm 实心焊丝

重型导向模块HD*: 适合药心焊丝或不锈钢焊丝, 直径范围为 .035 to 5/64" (0.9 - 2mm)

大型导向模块XL*: 适合焊丝直径范围为 3/32" to 5/32" (2.4 - 4mm)

▶ 3年质保! (工业化学品引起的损伤除外)

内部视图

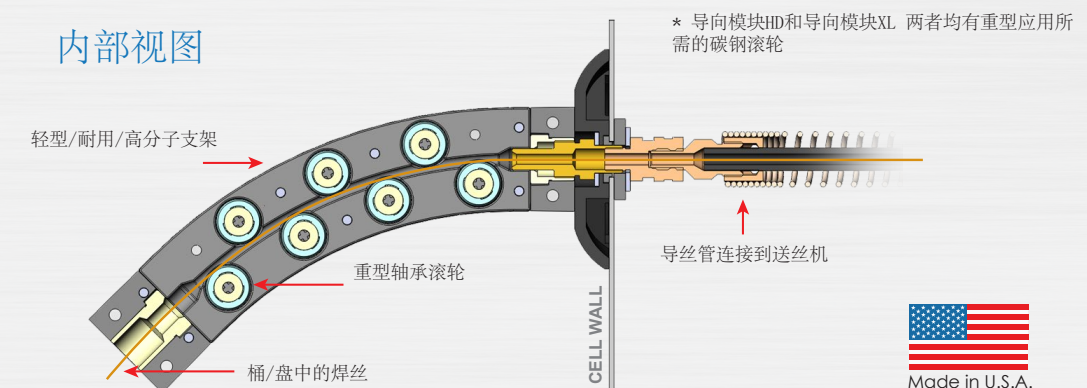

45° 导向模块应用



45° 导向模块

WGM-1
实心焊丝直径
<5/64" (2mm)

WGM-1-S
药心或不锈钢焊丝直径
<5/64" (2mm)

WGM-LW-1
大直径焊丝
5/64"到3/32"
(2mm-4mm)

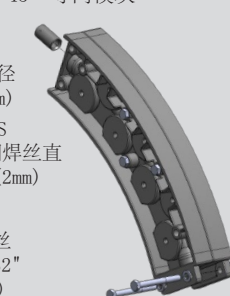

90° 导向模块

---6" (152mm)---

实心焊丝直径
<.052 (1.3mm)

Part # WGM-M-1
与WGM-1 封头一样



封头连接器

封头A 包含A & B封头
封头B

WGM-ECK-50
(使用 -25 匹配 A-4 或 A-4-ST)

WGM-ECK-LW-50 匹配 WGM-LW-1
(使用 -38 匹配 A-4HD)

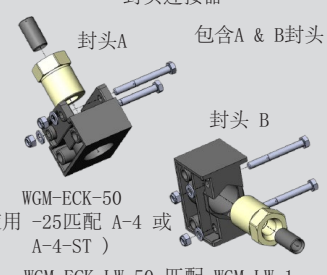

端面支架
360° 可调节

Part # WGM-A-10BK

绝缘连接器需增加 WGM-A5
或订购 WGM-2-BRKT



导丝管连接器

螺纹连接器
A-10HM
EC-4-R
A-10XM
匹配 FC-X
A-10RM
匹配 FC-XH & EC-5
A-9
匹配 FC-XH-LW

快插接头
WGM-A5
绝缘接头
A-5 匹配
WGM-1 & WGM-1-S
A-4HD 匹配
WGM-1-LW

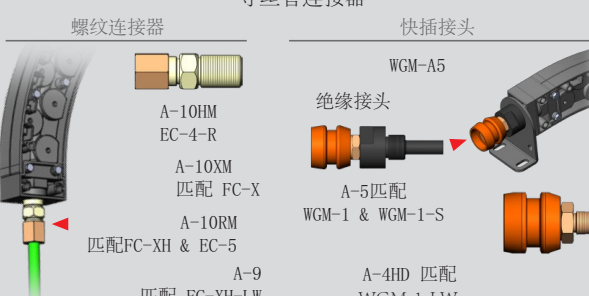

安装支架
可360° 调节

Part # WGM-2-BRKT

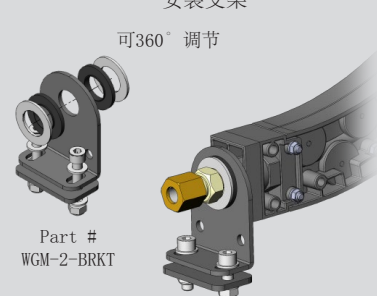

桶帽安装包

Part # WGM-DK

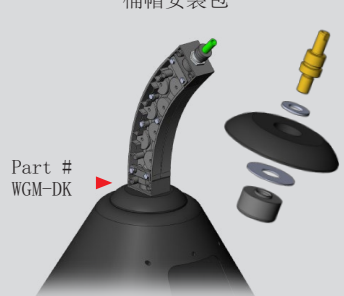

导丝管 & 配件

EC-3-R (4.4mm I.D.)
配件: A-16F-3 或 A-10C-S

EC-4-R (7.6mm I.D.)
配件: A-16F-4 或 A-10C-H

EC-5 (10.2mm I.D.)
配件: A-16F-5 或 A-10R

EC-6 (14mm I.D.)
配件: A-16-F-6 或 A-9

螺纹配件 (A-16F-#)
WGM-A5 绝缘连接器
导向模块封头

螺纹连接器

快插配件 (A-10#)
A-5 快插

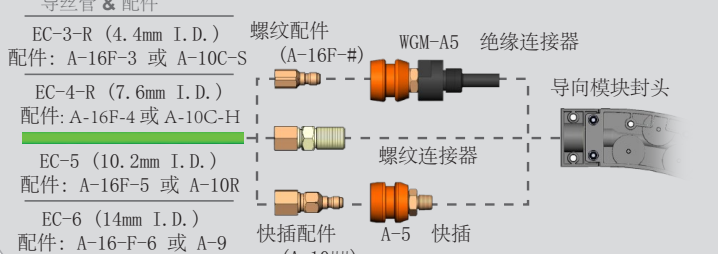

导丝管 & 配件

FC-X (6.1mm I.D.)
配件: A-10C-X

FC-XH (7.4mm I.D.)
配件: A-10R

FC-XH-LW (10mm I.D.)
配件: A-9

FC-X-SW* (2.3mm I.D.)
仅限直径<.035焊丝 (仅限剪切好的导丝管)

WIRE WIZARD® 柔性导丝管

快插配件 (A-10#)
WGM-A5 绝缘连接器
导向模块封头

螺纹连接器

螺纹配件 A-5 快速接头



导向模块直拉入口

Part # WGM-DP-LW
陶瓷接口避免焊丝晃动



桶帽旋转件
可360° 旋转

Part # WGM-HSK-15



导向模块旋转件
可360° 旋转

Part # WGM-FSK-14
可360° 旋转

Part # WGM-FSK-L
可匹配林肯送丝机

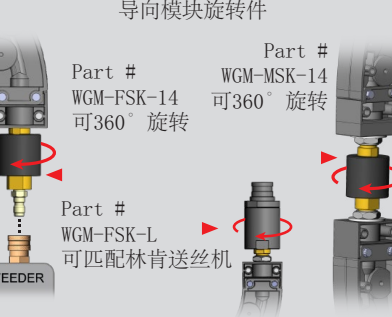

旋转件的附加装置

Part # WGM-PFA-SW-15
匹配 Wire Pilot® Feed Assist

Part # WGM-NSW-SW
匹配 Non-Stop™ Dispensing System

使用 Part # WGM-PFA-AK-15
做固定

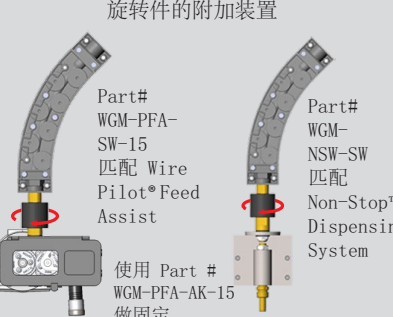

墙面单边安装支架

Part # WGM-WK-1-1



墙面双边安装支架

Part # WGM-WK-2-1



可调节的墙面支架

Part # WGM-WK-1-3
壁厚可调节至 3" (76 mm)

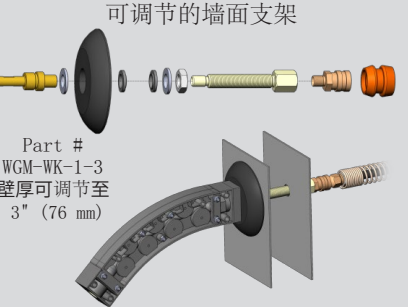

地板安装支架

Part # WGM-FLM

两边都可连接导向模块



45° 悬挂模块支架

Part # WGM-1-BRKT



90° 悬挂支架

Part # WGM-1-90-BRKT
(WGM-LW-BRKT 匹配 WGM-LW-1)

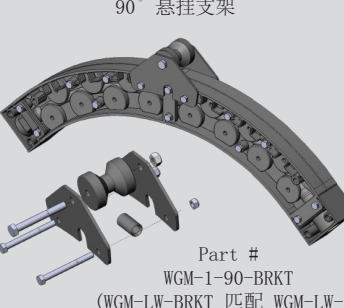

可堆叠的导向模块支架
可堆放层数为3

Part # WGM-SMB-3

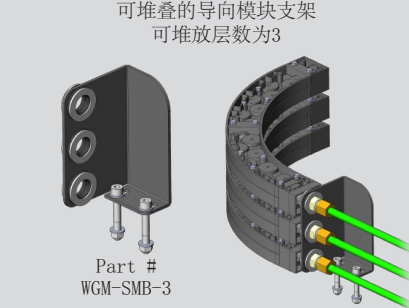

送丝接入配件

Part # WGM-1K
不包含支架

支架样品安装演示

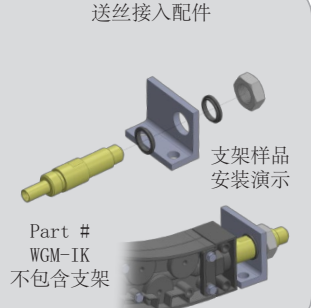

导向模块底座
应用于桶装或木制的盘装焊丝

Part # WGM-PFA-STAND
包含底座和可延伸臂

90° 旋转模块

WWDP 直拉元件

桶或木制的盘装

Wire Pilot® 送丝配件选择

WGM-A-10BK

盘装焊丝选择 WGM-PFA-STAND-4

高度调节范围 50" - 86" (1.3-2.2m)

臂长调节范围 4" - 19" (102-483mm)



中间层应用的导向模块
应用于焊丝位置高于焊接设备时

Part # WGM-3-BRKT
侧支架

桶或木制的盘装

Wire Wizard® 防火桶套

WWDP 直拉元件

Conduit to wire feeder

增加的臂 part # WGM-PFA-STAND-ARM

高度调节范围 50" - 86" (1.3-2.2m)

臂长调节范围 from 4" - 19" (102-483mm)

Part # WGM-PFA-STAND



L-支架元件

Part # WGM-LBM-BRKT

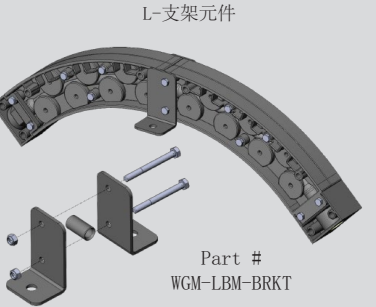

360° 连接适配器元件
可双面360° 调节

Part # WGM-UAU
包含支架

Part # WGM-UA
只有适配器元件

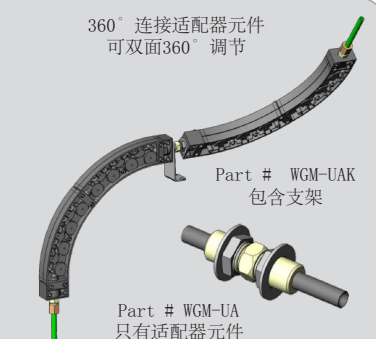

可调节的延长臂
安装于工作站顶部1

Part # WGM-CM-1
2" (51 mm) 延长到13" (330 mm), 高度可调节到6.5" (165 mm)

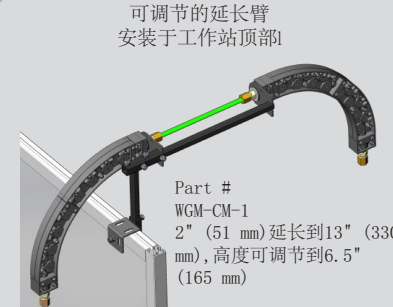

可旋转/可调节的延长臂
两臂均可向上旋转使送丝更容易

Part # WGM-EA-10
10" (254 mm) 延长到18" (457 mm)

Part # WGM-EA-20
20" (508 mm) 延长到36" (914 mm)

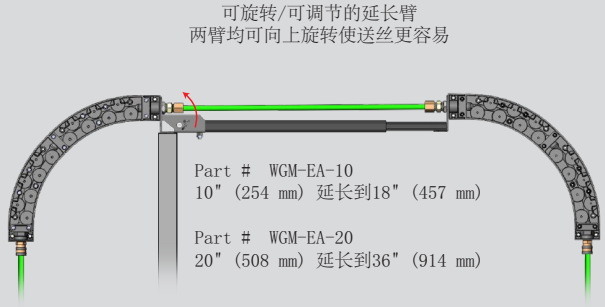

转向模块适配器

Part # WGM-4-BRKT

匹配 WGM-1, WGM-1-S & WGM-LW-1

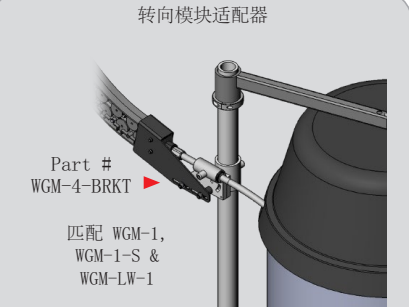

焊接或螺栓紧固的固定架

Part # WGM-044



支架

Part # WGM-021

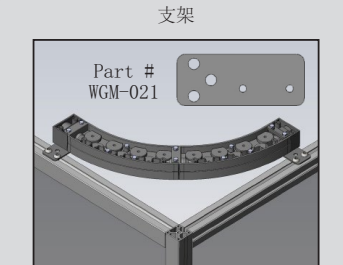

开槽支架

Part # WGM-024

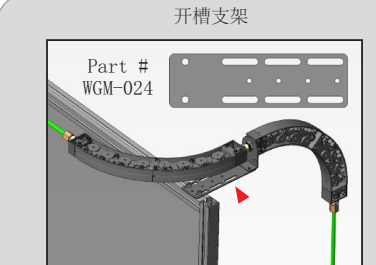

45° 支架

Part # WGM-025

