

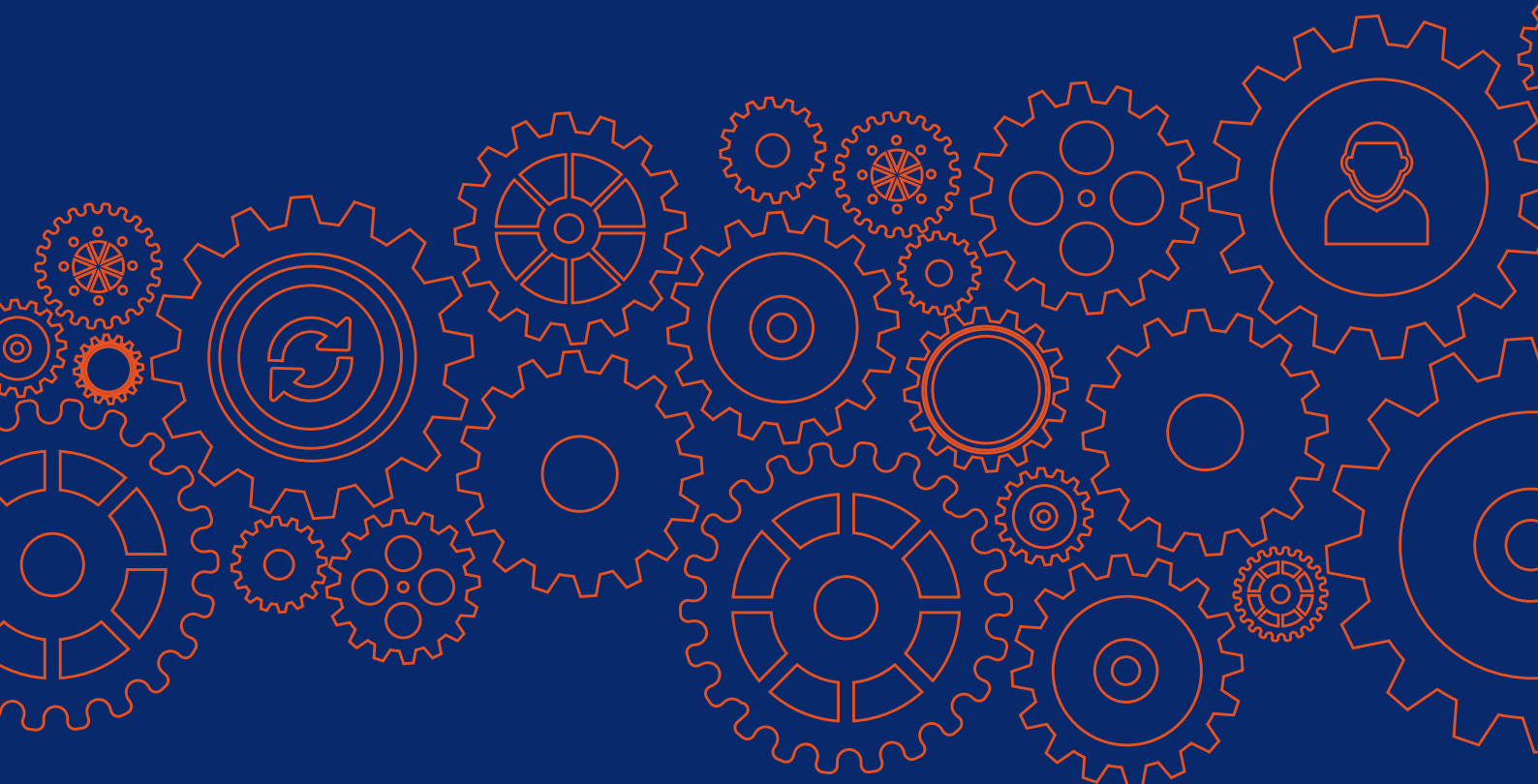

ENGINEERING

CAPABILITY STATEMENT



COMPANY PROFILE

EXPERIENCED ENGINEERS

E&C Engineering is an Australian-owned company providing turnkey solutions, in Industrial Automation and Control Systems (IACS, headquartered in Perth, Australia, and work with clients around the world.

We have decades of experience across numerous industry sectors in the provision of engineering services, incorporating: Automation, Advance Process Control, OT, Cybersecurity, Electrical, Instrumentation, and Functional Safety.

Our team specialises in mining process plant and power generation. We pride ourselves in our technical capabilities, experience, teamwork, and professional integrity.

UNDERSTANDING OUR CLIENTS' NEEDS

A key advantage of E&C Engineering is that we understand our clients' needs and wants. Like our clients, we have extensive experience in maintenance and operations and we are able to provide the smartest and effective solutions to process improvements.

Our exceptional delivery are:

- Providing a thorough problem analysis, and resolving root cause efficiently in a timely manner
- Knowledge sharing as a value-added benefit to clients
- Leadership by a registered Chartered Engineer
- Experienced engineers in operational and maintenance roles, providing practicable design
- Safety in design as standard practice

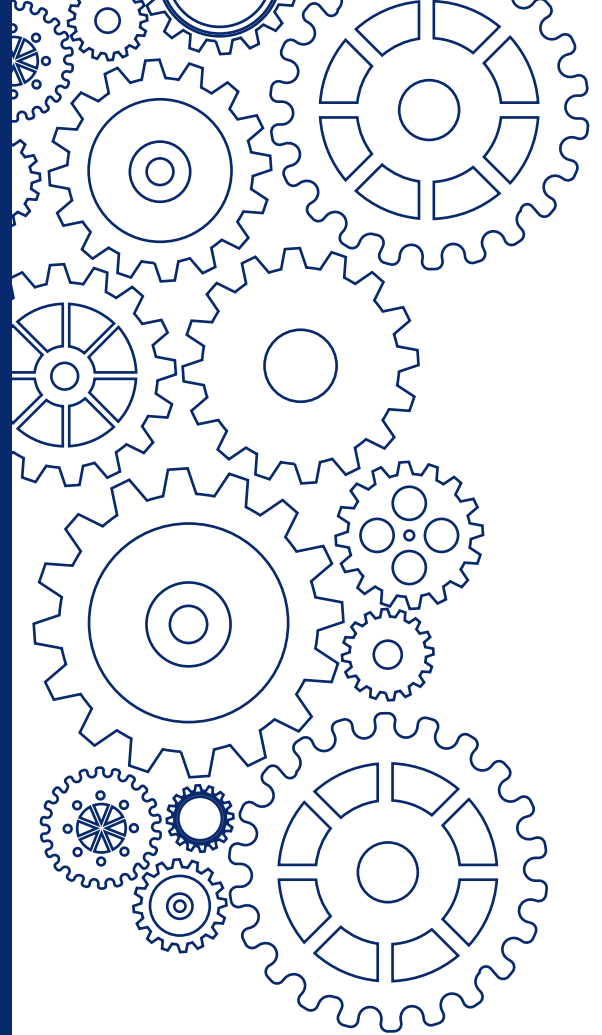

OUR VISION:

E&C Engineering is leading value creation for the resources industry by focusing on design reliability, operation optimisation, new technology adaptation, and engineering empowerment

OUR TEAM

The E&C Engineering team provide higher quality standards

We adhere to the principles of the Engineers Australia Code of Ethics, ensuring that the decisions we make support best practice and uphold our core values.

Our engineering team is led and supervised by a chartered lead engineer and registered in the Engineers Australia Register (NER.

Michael Wisesa, Director

The E&C Engineering team is managed by Michael Wisesa, a Chartered Engineer with 15+ years of experience in IACS, OT, operational support, and optimisation in the mining industry.

Michael holds an Honours degree in Electrical Engineering from Western Sydney University and occupied numerous senior engineering roles at leading organisations such as Calibre Global and Sedgman Limited.

Michael has worked extensively in design, commissioning, and site support, in mining and power generation, with experience covering iron ore, coal plant, materials handling, and gas engines.

OUR VALUES



Integrity

We operate our business with integrity at all times



Competency

We have extensive engineering competency



Leadership

We are leading effective solutions delivery



Sustainability

We are dedicated towards sustainable solutions



Respect

We value the importance of our clients' projects



KEY CAPABILITIES

INDUSTRIAL AUTOMATION AND CONTROL SYSTEMS

E&C Engineering provides professional engineering services for industrial automation and control systems discipline as well as electrical and network engineering.

We are experienced in various products and programming languages and our capabilities cover control systems, automation, advance process control, electrical, instrumentation, communication technology, cybersecurity, and functional safety.

We provide feasibility study, detailed design, implementation, commissioning, training and operational support for:

Automation and Control Systems

- PLC architecture design and software programming
- HMI and SCADA architecture design and programming
- Industrial communication protocol design and integration
- Control systems simulation and bench testing
- Standard and specification creation and implementation

PCN and Communication Technology

- Wired network architecture design and hardware configuration
- Wireless network architecture design and configuration
- Industrial fieldbus network design and device configuration
- Cybersecurity implementation in process control network

Instrumentation Design

- 3D Sensor, Radar profile, RFID, automated water cannon
- Online Condition Monitoring integration
- OT edge controller implementation

Electrical and Instrumentation

- Control panel design and build
- Motor control design and configuration (soft-starter, VVVF, LRS, DOL)
- Equipment calculation, sizing and specification
- Protection relay and arc flash configuration and programming
- UPS and Generator controller configuration and programming

Process Control Optimisation

- Process control scheme evaluation and design
- Advance process control implementation (TOC, MPC, SPC, Fuzzy Logic, etc.)
- Plant process debottlenecking and optimisation
- PID controller tuning and sequence control

Project Management and Execution

- Electrical and Control system project execution/supervision
- Operational Technology project execution/supervision

OUR SERVICES

We provide turnkey solution to multiple clients

CONTROL SYSTEMS

PLC programming:

- Schneider Electric (Control Expert, Concept, and ProWorx)
- Rockwell (RsLogix 500/5000, Studio 5000 Logix Designer, Fuzzy logic Designer)
- Emerson/General Electric PAC (Proficy ME)
- Beckhoff (TwinCAT3)
- WAGO/IFM (CODESYS)
- PILZ (PAS 4000)

HMI/SCADA programming:

- AVEVA Plant SCADA, System Platform, Vijeo Designer)
- General Electric (Cimplicity)
- Rockwell (Factory Talk View SE/ME)

Industrial communication configuration:

- Modbus RTU/ASCII
- Modbus TCP
- EtherNet/IP
- Profinet
- EtherCAT
- CANOpen
- OPC DA/UA

ELECTRICAL

Electrical design:

- Electrical drawings
- Technical specification
- Load study and calculation
- IO list
- Cable schedule
- Installation SoW

VVVF design and configuration:

- ABB (ACS, DCS)
- Rockwell (PowerFlex)
- Schneider Electric (Altivar)
- Siemens (Sinamics)

Instrumentation design and configuration

- Level
- Pressure
- Temperature
- Distance/profile
- Position
- Density
- Volume

Protection relay configuration:

- Motor
- Transformer
- Generator
- Busbar
- Feederr

Generator controller integration

- ComAp

NETWORK TECHNOLOGY

PCN design:

- Layer 2 (redundancy, switching, security, QoS)
- Layer 3 (redundancy, routing, ACL, industrial firewall)

Industrial network device configuration:

- Hirschmann (RSR, RSP, MSP, MAC)
- CISCO (IE3000, IE2000, IE4010)
- Rockwell (Stratix 5400, 5410, 5700, 8000, 8300)
- Schneider Electric (Connexium, JR900)
- Aviat (WTM3000)
- Cambium (PTP450, PTP670)
- MIRI (AD2000, AD2006)
- ELPRO (905U-G)

Fieldbus design and configuration:

- Profibus DP/PA, AS-i
- DeviceNet, ControlNet
- Modbus RTU/Modbus Plus
- IO-Link
- Hart

ADVANCE PROCESS CONTROL

Control scheme design:

- Cascade control
- Feed-forward control
- Constraint control
- Smith Predictor control
- Fuzzy logic control
- Model predictive control
- Plant feed management

Control systems optimisation:

- PID loop tuning
- Alarm rationalisation
- Process optimisation





THE WAY WE WORK

ENGAGEMENT FROM SCOPING TO DELIVERY

E&C Engineering works closely with its clients to understand their specific needs and challenges to develop a solution that meets the business needs and limiting the impact on operations.

To achieve we follow a four-step process from project scoping to delivery.

Scope of work:

Initial engagement to gain understanding of the client's needs. E&C Engineering team will offer valuable advice to narrow down the requirements and develop these into a scope of work.

Costing:

Once the initial engagement has been completed, the E&C Engineering team will present a detailed solution proposal with estimated or quoted costs.

Project delivery:

Once the scope of work and costs have been approved, the E&C Engineering team will execute the project as agreed.

Operational support:

Once the project has been successfully delivered, the E&C Engineering team will continue to assist the client to ensure the success of the project is maintained.

DEDICATED TO SAFETY IN DESIGN

As a trusted engineering designer and consultant, we are dedicated to promoting safety in design as a core aspect of our service.

Our objective in HSEQ management is to practice engineering services according to ISO 45001, ISO 14000, and ISO 9001 standards.

Our lead engineer, Michael Wisesa, holds Hirschmann HiOSL2 certifications with considerable interest in process control network cybersecurity adoption of ISA99 - IEC62443.

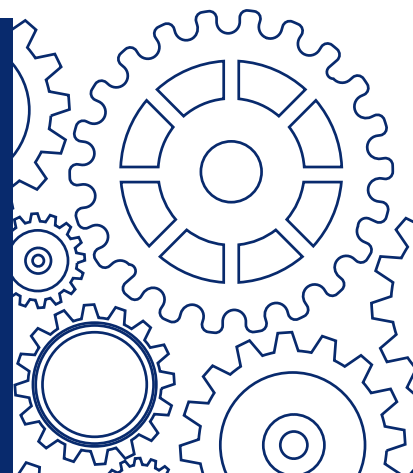



INDUSTRY SECTORS

CONSTRUCTION & ENGINEERING

Increased automation and adoption of new technologies are creating new control systems integration challenges in the construction industry. E&C Engineering can tailor solutions to meet these changing needs, helping companies to improve performance and increase productivity.

OT & COMMUNICATIONS

E&C Engineering understands the importance and value of secure and effective production critical communication technology management and works with clients to develop system integration solutions that facilitate security outcomes.

MINING AND METALS

Growing automation and the proliferation of new technologies across all facets of mining from corporate offices to site operations are placing new demands on mining companies. E&C Engineering has the experience and knowledge to develop automation and process control solutions to manage and improve productivity, efficiency and profitability gains.

UTILITIES: OIL, GAS & ENERGY

The energy sector is undergoing significant reform globally with renewable energy sources, digitisation, new technologies and increased process requirements creating unique challenges. E&C Engineering can apply its broad industry experience to design workable and effective solutions for utilities in challenging times.

PROFESSIONAL SERVICES

Technology, machine learning and the application of rich data are changing the way professional services companies do business and interact with consumers. E&C Engineering continuously work with businesses to develop solutions that optimise their business networks and processes, keeping them relevant and agile.

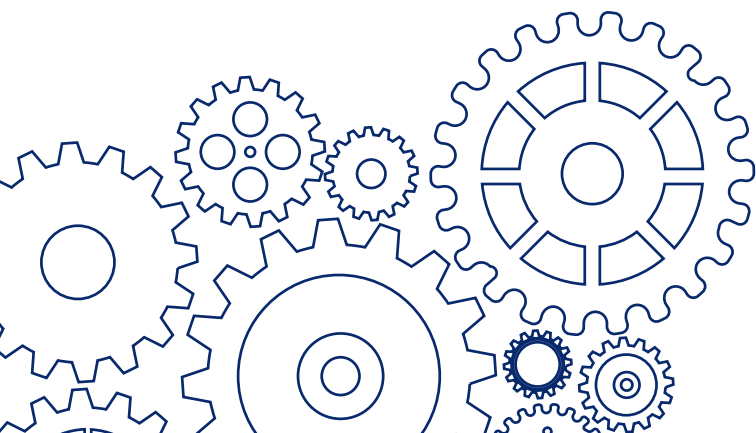



OUR CLIENTS

We provide engineering consultancy and operational support to clients in the mining industry, encompassing iron ore and coal plant, materials handling, and power generation.

Rio Tinto

We have completed projects at Rio Tinto sites in Western Australia in recent years, including process control network optimisation, upgrades to PLC hardware and software, seamless wireless radio redundancy system for stockyard balanced machines, and many more.

Fortescue Metal Group

We worked with Fortescue Metals Group in Western Australia to redesign process control network architecture and migration from Hirschmann to Stratix products.

We also provide site process control systems support as required.

STRATEGIC PARTNERS

E&C Engineering has strong relationships with a number of specialist partners to deliver effective and sustainable solutions suited to its clients' needs.

Tasman Power

Specialists in providing electrical services in WA's north west including; electrical and instrumentation installations, upgrades, and ongoing support.

Fusion Networks Australia

More than a decade of experience in telecommunication and remote mining communications with Rio Tinto, BHP, Fortescue, Telecom NZ, Transfield, Downer, Calibre, Fast, Lycopodium, Fluor, GHD, KBR, and SKM.

Ultimate Energy Engineering

Power generation specialist for mining, island grids, standby power, remote communities, hospitals, hybrid systems

RioTinto



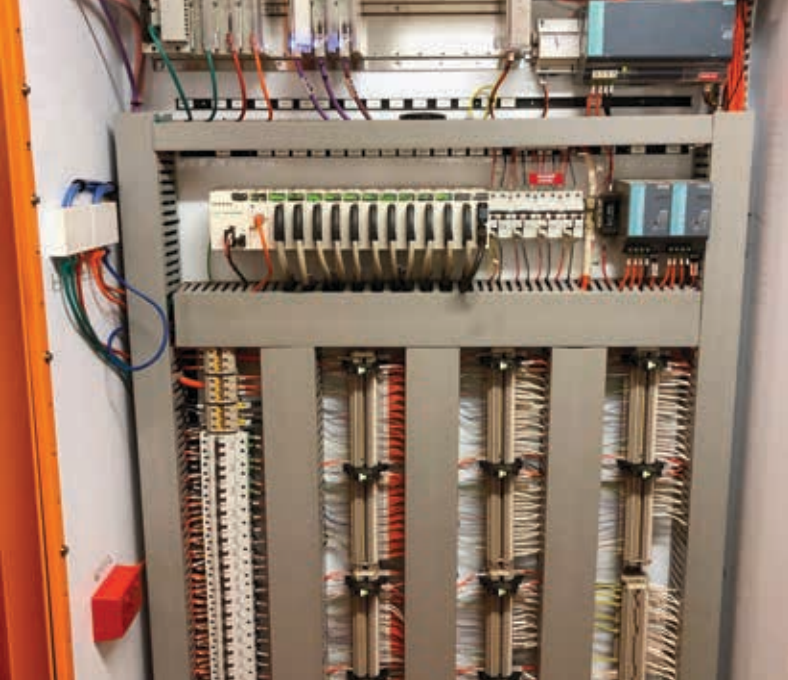

OUR CORE COMPETENCIES

SE CONCEPT & PROWORX TO CONTROL EXPERT

E&C Engineering successfully upgraded various plant PLC from Concept and Proworx to Control Expert in a rapid pace, delivering a fault free result. This was achieved through a methodical approach in engineering design, checks, testing, commissioning, and acceptance. As a result, E&C was able to solve its clients' problem with minimum to no interruption to operation.

PLC DATA BACKUP & RESTORE SYSTEM

E&C Engineering has successfully used SCADA systems to implement automatic backup and restore functions for PLC data. This has included a configuration of a SCADA tool to restore PLC data automatically.

HIRSCHMANN CRITICAL NETWORK OPTIMISATION

E&C Engineering was engaged to rectify broadcast network storm issue in a large critical production network caused by unfiltered network traffic in a significant broadcast domain. Network protection were done with several techniques and features on the managed switch

As a result, E&C was able to establish a resilient critical production network that minimised and localised the network broadcast storm and its source.

HV REMOTE SWITCHING PANEL INTEGRATION

E&C Engineering was trusted to do an engineering design study to provide a remote operating panel for the MV switchgear using Schneider Electric HMI and SCADA products for ABB relays. E&C Engineering not only managed to meet the client needs but also exceed expectation by creating user friendly templates for the client to scale up the project implementation.

POWER STATION DESIGN & COMMISSIONING

E&C Engineering was appointed to execute final control systems integration, commissioning, and handover of 200MW Power Station. Control systems scope include PCN design and configuration, RTAC, Protection Relay, Fire and Gas system, Balance of Plant controller, engine controller, and supervisory controller integration. Project execution was completed in a safe, cost effective, and efficient way.

TURNKEY SOLUTIONS

E&C Engineering delivers turnkey solutions in brownfield and greenfield industrial sites, encompassing control systems, network and communications, electrical and instrumentation, process control optimisation, and systems integration.

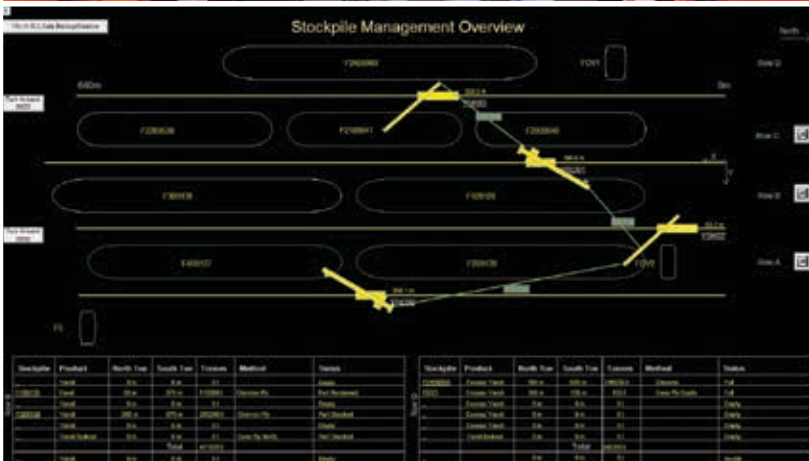
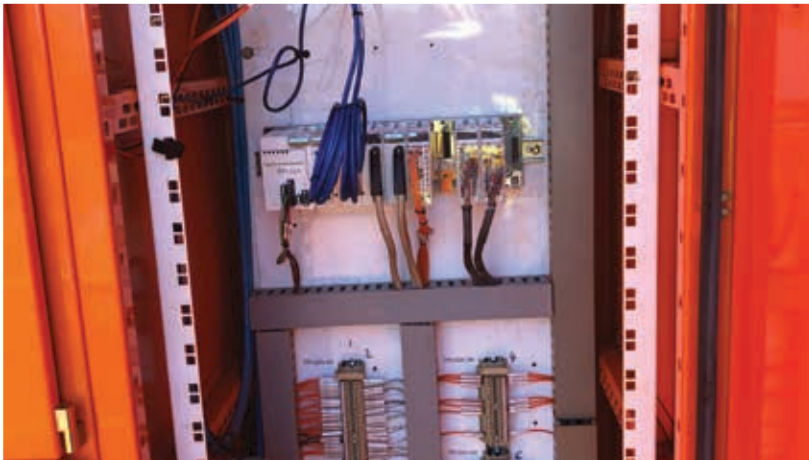

Client: Fusion Networks (FMG)

Project: Hirschmann MICE to Rockwell Stratix switch migration

Year: 2020

Value: \$100,000

Scope of work: Provide configuration specifications, solutions, and implementation to migrate control systems network products from Hirschmann (Power MICE) to Rockwell (Stratix).

Work completed: Standardise Layer 2 and Layer 3 network switch implementation to process control network and integration to corporate/IT network with the introduction of ring and sub-ring redundancies.

Result: The implementation was run smoothly on time and on budget with minimum downtime required.

Client: Tasman Power (Rio Tinto)

Project: Schneider Electric Prowox 32 to Unity Pro XL upgrade

Year: 2019

Value: \$100,000

Scope of work: Provide engineering services to upgrade PLC hardware and software for the Stockyard Management System PLC and Water Pumping Stations.

Work completed: Electrical and control systems design from Quantum platform to X80 platform, and migrating LL984 ladder logic to Unity Pro Function Block

Result: The client trusted us to implement the upgraded Stockyard Management Systems PLC straight after FAT and it was implemented early with no errors.



Client: Tasman Power (Rio Tinto)

Project: Ore product profiler instrumentation design and system integration

Year: 2019

Value: \$100,000

Scope of work: Deliver electrical and control systems packages to provide a cost-effective profiling solution for vacuum belt filter cake thickness.

Work completed: The cake thickness profiler solution was delivered for four belt filters on site.

Result: The project was completed on time and on budget and met all client requirements.

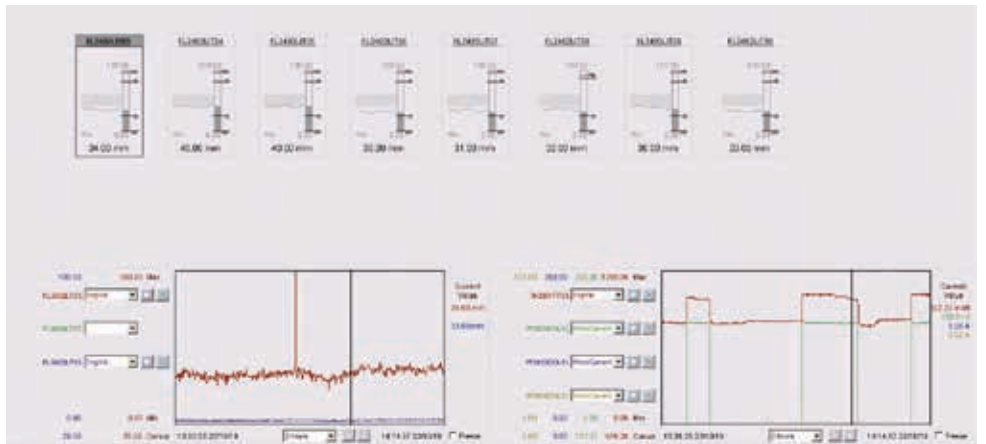
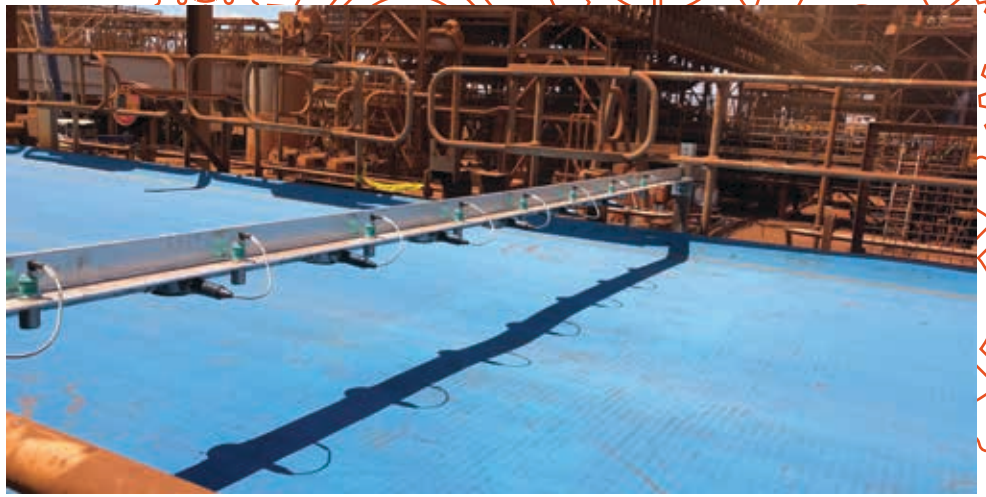

System Status - Master		
Equipment		
Attributes	Value	Units
Link Name	YSK02	
Site Name	RTIO Yandicoogina (YSR28)	
Software Version	50650-01-42	
Hardware Version	B0P05.00-1	
Unit ESN	0004565090FF	
Unit MSN	U9SK00876TTH	
Regulatory Band	3 - 5.8 GHz - Australia	
Elapsed Time Indicator	159 Days 21:52:08	
Ethernet / Internet		
Main PSU Port Status	Copper Link Up	
Main PSU Port Speed And Duplex	100 Mbps Full Duplex	
MAC Address	00:04:56:50:90:ff	
Remote MAC Address	00:04:56:50:5d:cf	
Remote Internet Address	http://10.192.128.218	
TDD Synchronization		
TDD Synchronization Interface	Disabled	
Status Page Refresh Period	3600	Seconds
Attributes	Value	Units
Spectrum Management Page Refresh Period	3600	seconds
Tx Color Code	A	
Asymmetric DSO	<input checked="" type="radio"/> Disabled <input type="radio"/> Enabled	
Hopping Counter	233 (+0)	
Channel Bandwidth	10	MHz

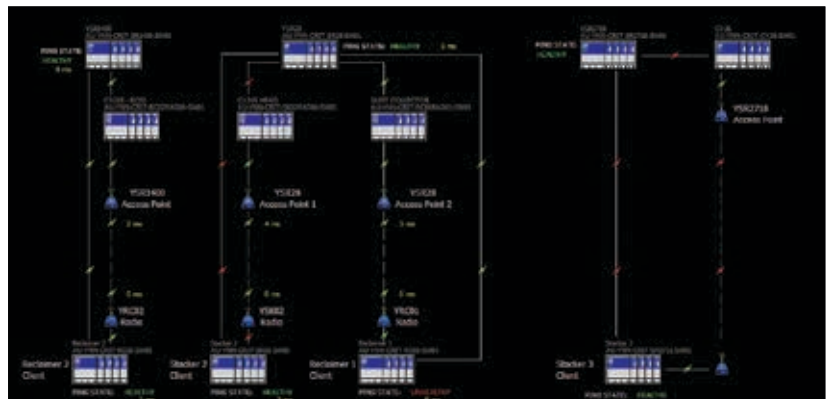

Client: Tasman Power (Rio Tinto)

Project: Railed machines seamless radio back-up redundancy

Year: 2016

Value: \$175,000

Scope of work: Provide an engineering solution to deliver a seamless communication redundancy using wireless radio technology in the process control network for Stockyard balanced machine.

Work Completed: Point to point redundancy was installed for four balanced machines and ring redundancy technology provided in the network switch.

Result: The radio link was tested for a week with no interruption and the ring redundancy switched seamlessly from fiber link to radio link. The entire project was completed on time and on budget.

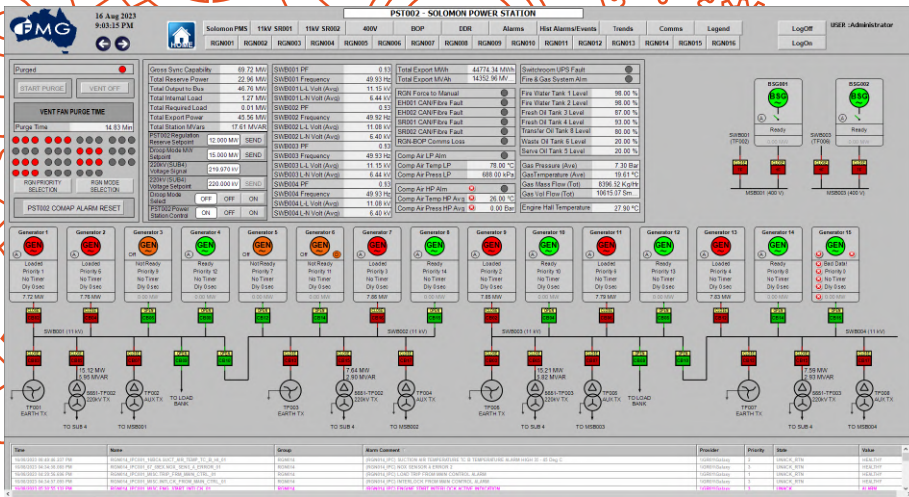

Client: Tasman Power (Rio Tinto)

Project: Yandicoogina Remote Switching Panel HMI Upgrade

Year: 2022

Value: \$150,000

Scope of work: Provide electrical, network, and control systems design, FAT, commissioning, and handover of HMI Panel Upgrade

Work completed: Design HMI Panel architecture, Protection relay data collection and distribution for PLC and SCADA, Switchgear remote control via HMI and SCADA

Result: Turnkey (Electrical, network, and control system) project executed on time and on budget with no interruption to plant operation

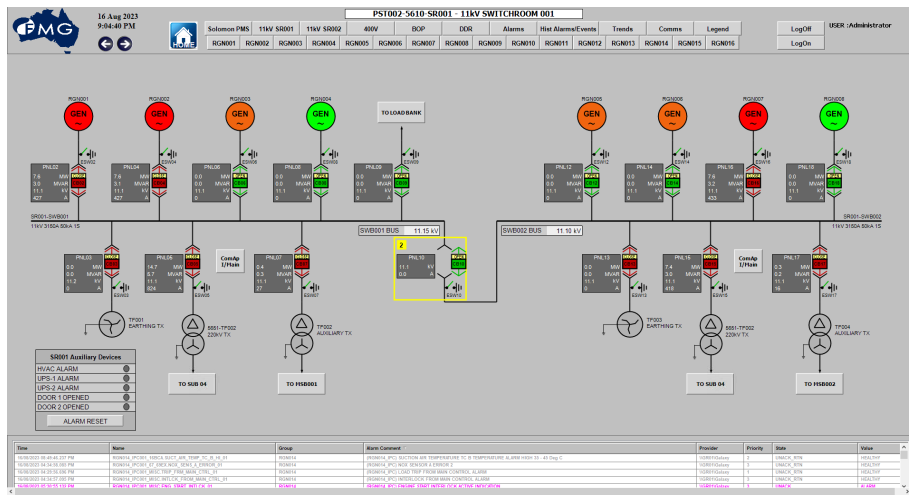

Client: Pacific Energy (FMG)

Project: Solomon 200MW Power Station Commissioning

Year: 2022-2023

Value: \$500,000

Scope of work: Provide control system project management, design, commissioning, close out, and operational support of the newly built PST002 Power Station

Work completed: Design integration of Process Control Network, GPS Clock, Firewall, RTAC, Disturbance Recorder, HV Protection Relay, ComAp, Engine Controller, Fire & Gas System, SCADA, and ESXi build

Result: The client trusted us with cost effective implementation, commissioning, and handover to operational team

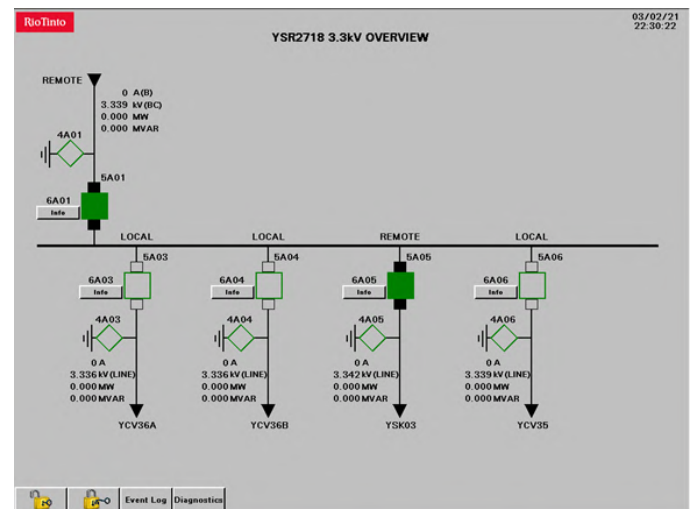

Client: Tasman Power (Rio Tinto)

Project: Paraburdo
Profibus PA Device Network
Upgrade

Year: 2021

Value: \$150,000

Scope of work: Provide control systems design, FAT, commissioning, close out, and operational support.

Work completed: Design transparent Profibus PA communication to 80+ instrumentation, Decommission third party controller (Siemens PCS7 PC), Handover upgraded Profibus PA network with remote configuration ability to individual instrument.

Result: Turnkey (Electrical, network, and control system) project executed on time and provide saving up to \$500,000 due to exceptional design and knowledge of Profibus PA



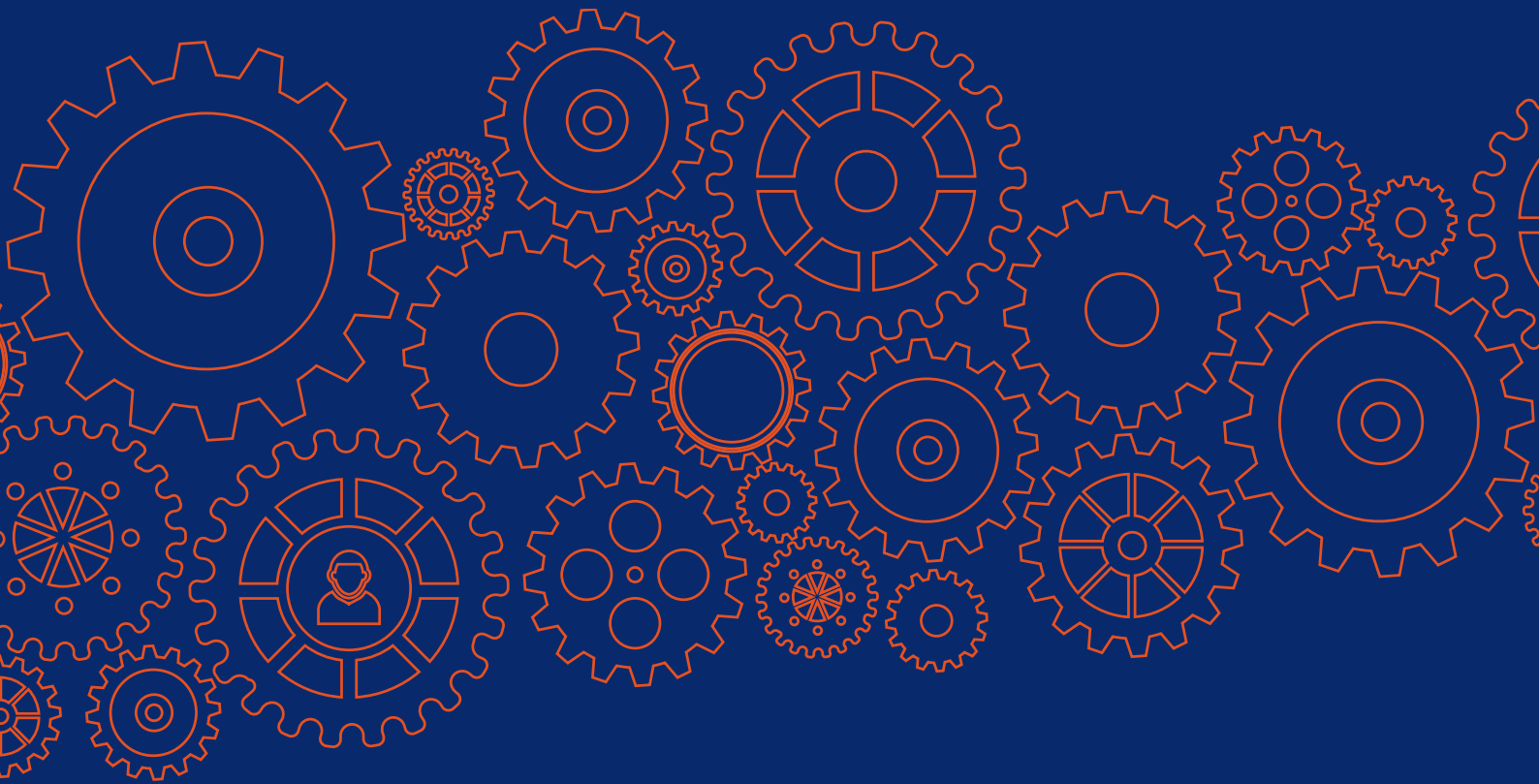

CONTACT INFORMATION

A: Unit 15, 64-66 Bannister Road
Canning Vale WA 6155

P: +61 8 6323 2123

E: info@ecengineering.com.au

W: <https://ecengineering.com.au>

