

**HebTech, LLC**  
**Digital Resistance Tester – Model 5050-06XP**



Specifications & Dimensions	2
Theory of Operation	2-3
Operator Controls & Connectors	4
Test Connections	5
Calibration Procedure	6-7
Options	8
RS-232 Configuration	9-10
Temperature Compensation Option	11
Temperature Compensation Calibration	12
Trouble Shooting Hints	13-14
Return Policy	14
Warranty	15
Assembly Drawings	15-16

## SPECIFICATIONS

<i>ACCURACY (% FULL SCALE)</i>	$\pm 0.02\%$ (Includes +/- 1 digit) at 25 ° C $\pm 0.001\%$ per ° C from 0 to 70 ° C
<i>RANGES</i>	0 to .1999, 1.999, 19.99, 199.9, 1.999K, 19.99K Ohms
<i>DISPLAY</i>	4 ½ digit LED Display and 5 ½ Digit RS-232 Output
<i>READING RATE</i>	4 readings per second (minimum)
<i>TERMINALS</i>	Max. Full-scale voltage is 2.0 Volts and less than 100 mA. Current
<i>POWER REQUIREMENTS</i>	117 VAC +/- 10 %, 50-60 Hz, 5 Watts. 2 amp Slo-Blo fuse (230 VAC optional)
<i>TEST CONNECTIONS</i>	4 wire Kelvin required
<i>CONNECTORS</i>	Rear panel MS-style circular connector and front panel banana jacks
<i>LIMIT ALARM TERMINALS</i>	Dry contacts rated at 2A. At 117 VAC

## DIMENSIONS

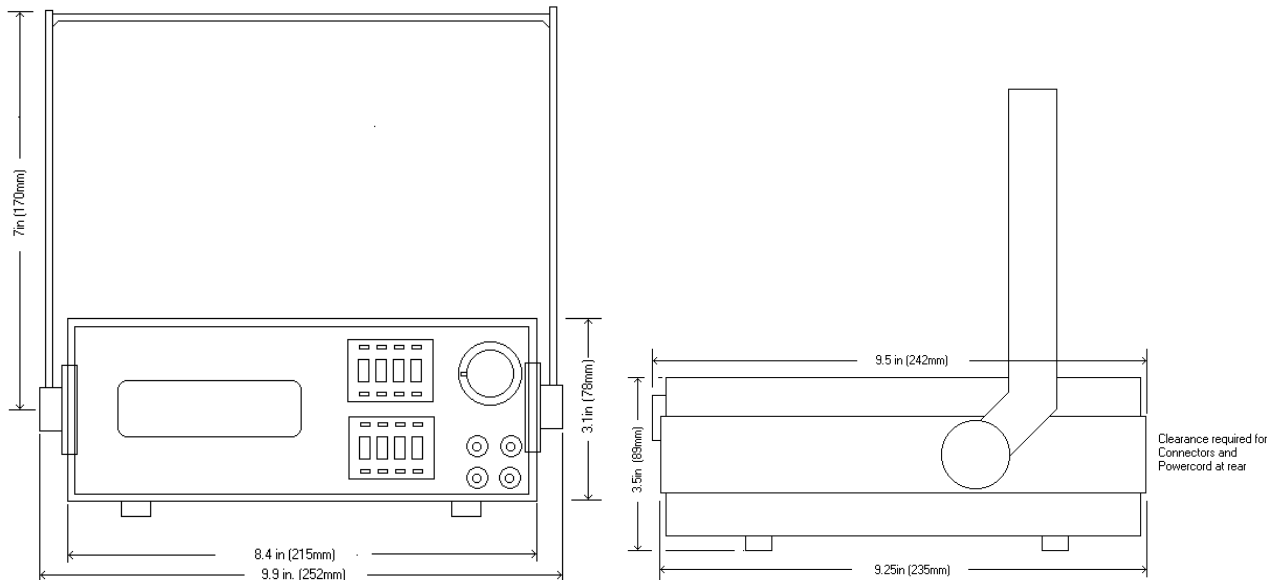

## THEORY of OPERATION

The HebTech, LLC Model 5050-06XP Resistance Tester is a digital ohmmeter that includes a precision constant current source which drives a known current through an unknown resistance. It features four readings per second and a temperature compensated voltage reference serving both the DVM and the constant current source. This results in a stable calibration reference. A digital voltmeter measures the

potential across the resistance and presents a digital display of the resistance in Ohms.

The 16F877 Microprocessor based circuit includes a dual limit comparator which compares the measured resistance with upper and lower tolerance values entered on front panel thumbwheels. Red and green front panel light emitting diodes indicate whether or not the resistance is within tolerance. An output relay permits the resistance tester to be converted to a rejection device. For “fail-safe” operation the contacts are normally open. The contacts close if the part is within tolerance. The Microprocessor based circuit also provides for electronic range switching and system control.

**BLOCK DIAGRAM of Main X Series Ohmmeter Board**

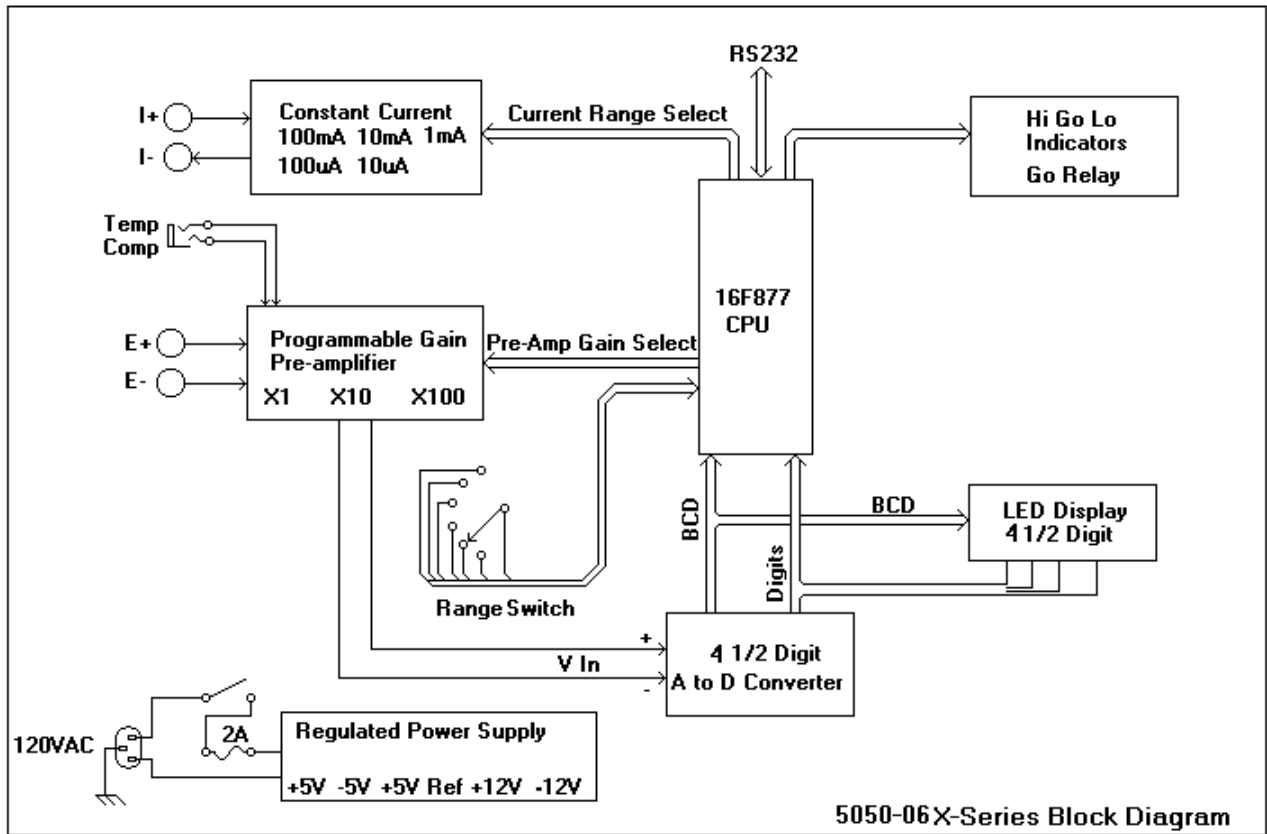

# OPERATION of UNIT

## FRONT PANEL VIEW:

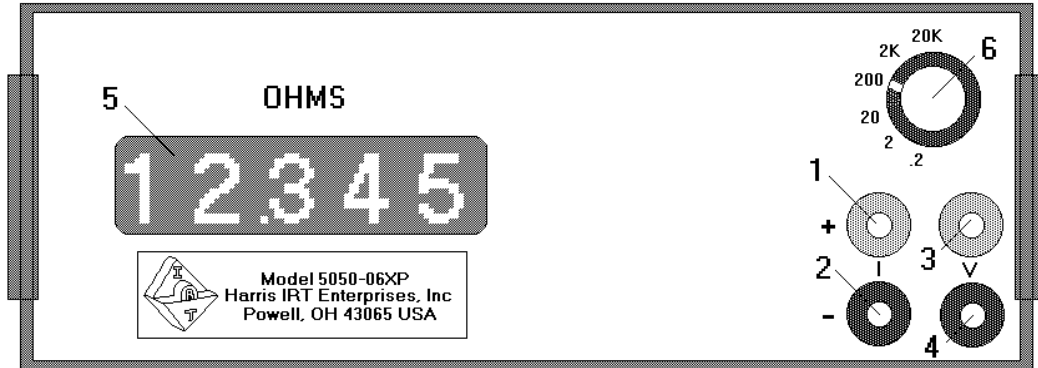

- 1. Current Terminal (Constant Current Source)
- 2. Current Terminal (Constant Current Sink)
- 3. Differential Voltage Input -
- 4. Differential Voltage Input +
- 5. LED Digital Display (4 1/2 Digit Max 19999)
- 6. Range Selector Switch

## REAR PANEL VIEW:

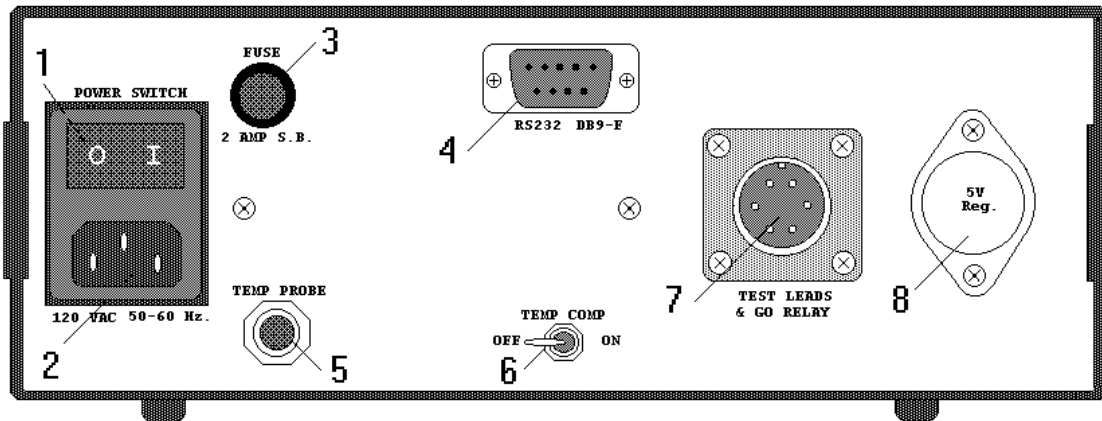

- 1. Power On-Off Switch
- 2. Power Entry Connector (120V 50-60Hz.)
- 3. 2 Amp 3AG Slo-Blo Fuse (Power Line)
- 4. RS232 Serial Port (9600, N, 8, 1 default)
- 5. Temperature Compensation Probe Jack
- 6. Temperature Compensation Switch (On/Off)
- 7. MS Style Kelvin Connections and Go Relay Out
- 8. Regulator (Insulated from Case) 5 Volt

**TEST CONNECTIONS:**

**NOTE:**

*For greatest accuracy each voltage and current lead must connect separately to the component under test. This is most critical in low resistance measurements.*

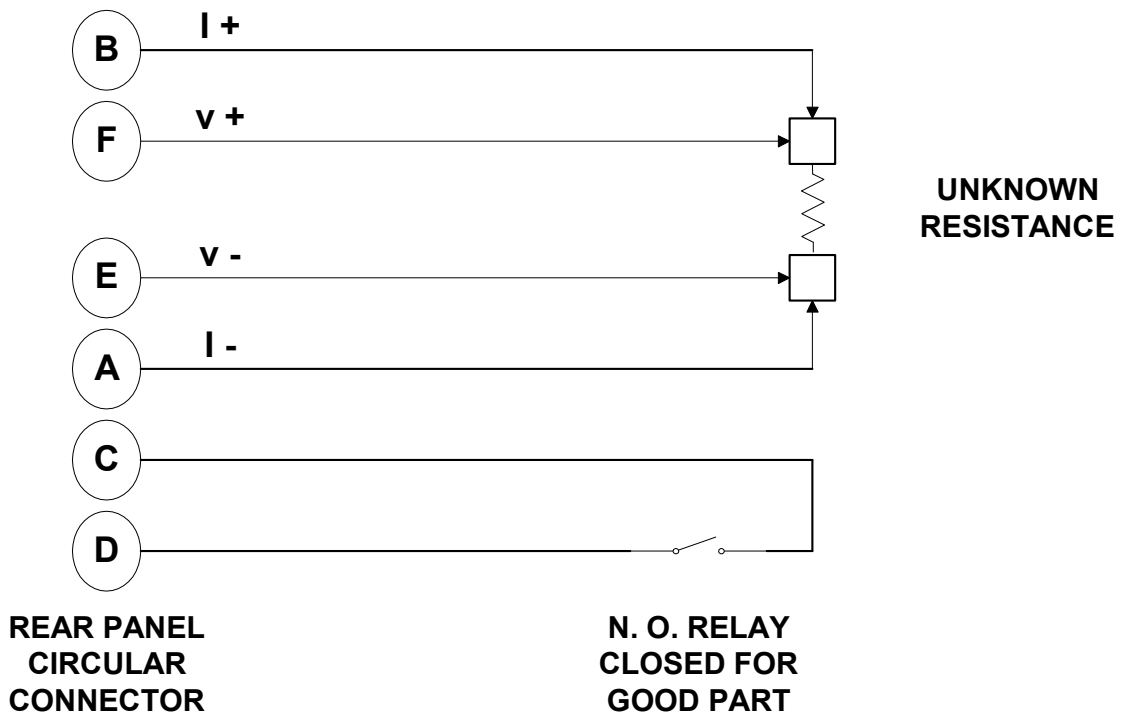
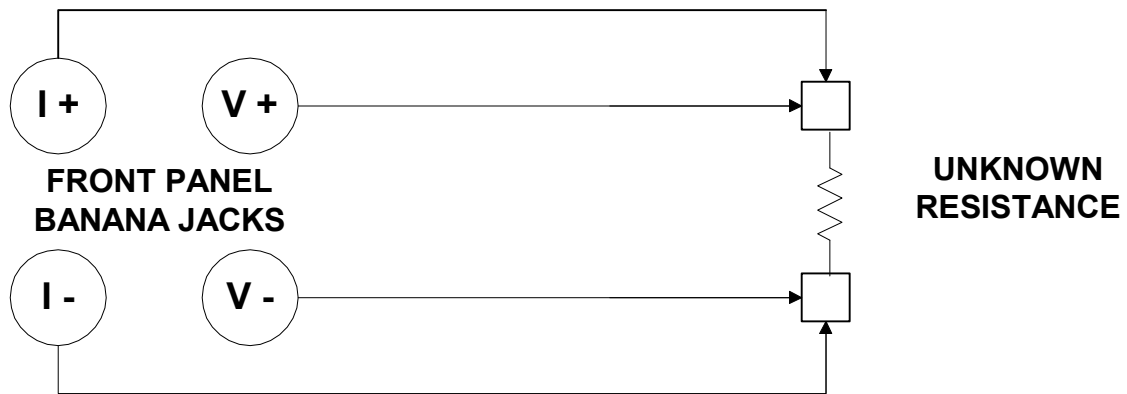

## 5050-06XP CALIBRATION PROCEDURE

### **REQUIRED EQUIPMENT:**

A digital voltmeter with a 4½ digit resolution and a 200 millivolt full scale range is required. You will need a set of six standard resistances, one for each range to be calibrated. A precision of at least 0.02% is necessary to calibrate this instrument to specifications. HebTech, LLC can supply a 0.02% resistance set, Model 2005, with standard resistances and switchable Kelvin connections.

#### Recommended standard resistance

199.90 Milliohms (if .2 Ohm range)

1.9900 Ohms

19.900 Ohms

199.00 Ohms

1990.0 Ohms

19,900 Ohms

199,000 Ohms (if 200K range)

#### **NOTE:**

*The resistances must be just below the full scale value of each range.*

It is important to check the instrument calibration before attempting any adjustments. The Calibration check procedure is listed below. A suitable set of 4-wire Kelvin test leads will be required for connecting the standard resistances to the instrument. Either the front panel jacks or the rear panel MS-Style connector may be used for the Kelvin test leads.

**Calibration Check:** Turn Power On to the instrument and allow a five minute warm-up time before checking calibration. **Be certain that temperature compensation switch is turned to the 'OFF' position while checking calibration or adjusting calibration.** Check each range using a certified standard value near full scale for the range being checked. All readings must be within 2 counts of the certified value near full scale. Next check all ranges at 10% of full scale using the certified standard for the next lower range. Again the readings must be within 2 counts of the certified value. Note that 1 additional digit of 'dither' is permitted by the specifications. **If the instrument meets these specifications on all ranges, do not perform a calibration procedure.** You will eventually wear out the adjustment potentiometers. If all of the ranges require major adjustment, there is likely a component failure or some problem in the test setup.

#### **Calibration Procedure:**

**Note: Adjustment locations are shown on the next page.**

1. Connect the Kelvin Test leads as follows: Solder together the wires from the E+, E-, and I- terminals. Select the 0.2-Ohm range (if it is provided) or the 2-Ohm range if that is the

lowest range. Adjust the **ZERO** potentiometer for a display reading of 0000.

2. Connect a 19900-Ohm standard to the four wire Kelvin test leads and select the 20K Ohm range. Connect a 4 ½-Digit voltmeter across the standard resistor and adjust the potentiometer marked '**I x 1**' until a voltage of 1.9900-V is indicated on the voltmeter. You may also adjust the potentiometer marked **100µA** if more range is needed. With the external voltmeter removed, the 5050-06XP display should be within a percent or so of the correct reading at this point. The **I x 1** control can be used to bring the ohmmeter reading to the exact value of the standard resistor used.
3. If a 200K Ohm range is provided on this Ohmmeter, connect the 199,000-Ohm Standard to the Kelvin test leads and select the 200K range on the ohmmeter. Adjust the potentiometer marked '**I x.1**' until the Ohmmeter display reads the certified value of the standard resistor.
4. Connect the 1.9900-Ohm standard and select the 2-Ohm Range. Adjust the '**E x 10**' control until the certified value is displayed on the Ohmmeter.
5. Connect the 19.900-Ohm standard resistor and select the 20-Ohm range. Adjust the control marked 10 mA until the Ohmmeter display indicates the certified value of this standard.
6. Connect the 199.00-Ohm standard resistor to the Kelvin test leads and select the 200-Ohm range. Adjust the 1 mA potentiometer until the certified value is displayed.
7. Connect the 1990.0-Ohm standard and select the 2K Ohm range. Adjust the 100 µA potentiometer until the proper resistance value is displayed. (This value should not require adjustment since it was part of the 20K calibration.)
8. Perform a complete calibration check as described at the beginning of this procedure. Your calibration should now be within factory specifications. An annual calibration check is recommended to keep your instrument within specifications.

## 5050-06XP Component and Adjustment Locations:

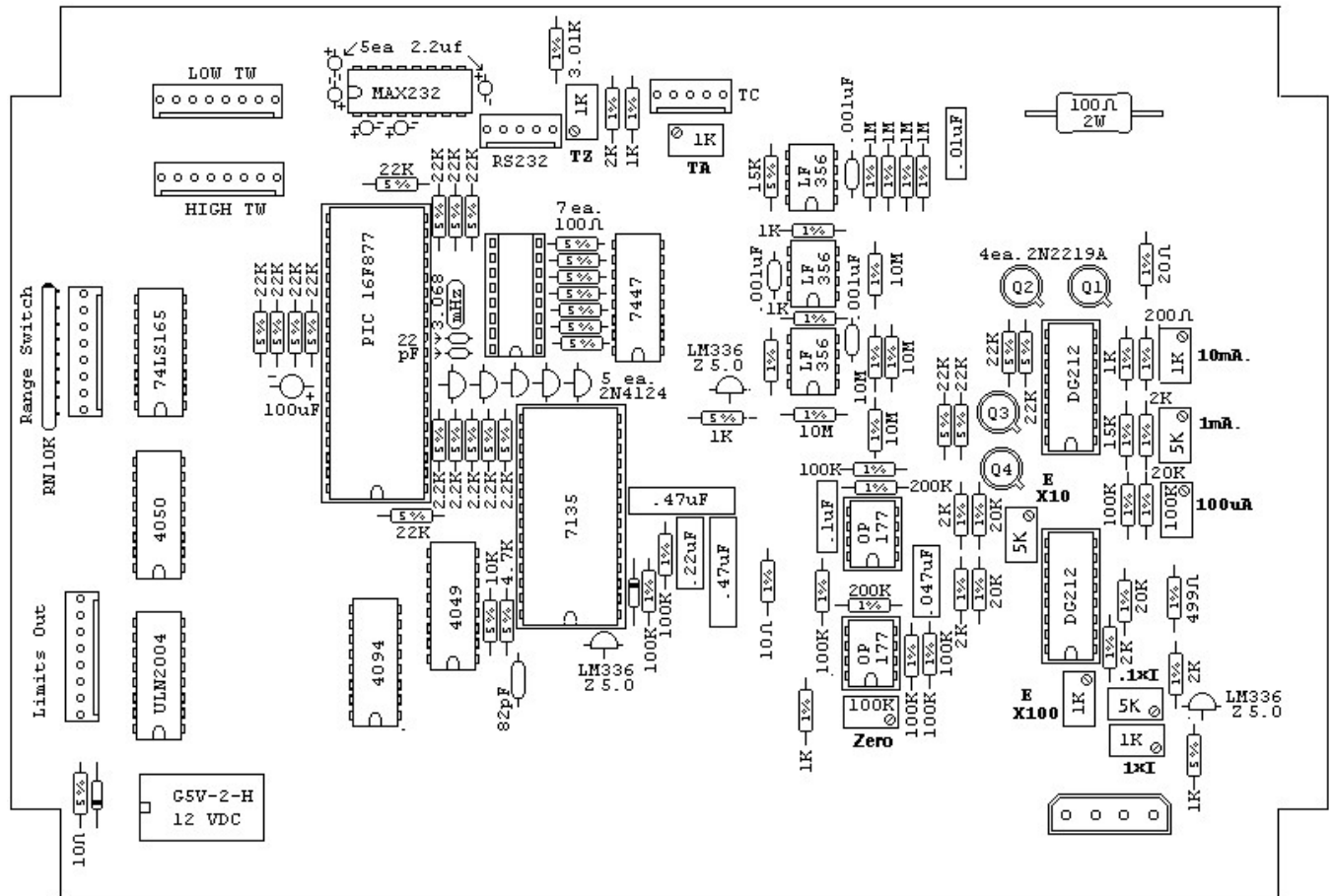

## OPTIONS

### TEMPERATURE COMPENSATION ( TC ):

Temperature changes of a few degrees in a product can have significant effects on the product's resistance. Therefore, the need for temperature compensation may arise when the temperature of the part being tested changes over a period of time.

The benefits of temperature compensation include the saving of time, energy, and money by eliminating the need to refer to coefficient tables as the ambient plant temperature varies during the day. Before now, such compensation was available only in expensive and delicate laboratory-grade instruments. HebTech, LLC has now made it available in rugged resistance testers designed for use in production.

With temperature compensation, a probe sends ambient temperature data to the instrument. This temperature information is used to modify the constant current that is being passed through the part under test. The resistance then registered is the resistance the item under test would have at the specified



temperature. The compensation option can be calibrated for the measurement of either of two measurement coefficients or it can be operated without any compensation. The accuracy of the compensation is within 0.2 % of the actual resistance between 0 and 50°C.

### ***BINARY CODED DECIMAL ( BCD ):***

BCD is not available on the portable –XP Series Ohmmeters. It is available in the Rack Mount –XR series cases.

The BCD output allows the resistance tester to transmit readings to a Programmable Logic Controller (PLC). The BCD option generates a 1, 2, 4, and 8 bit for each of the 5 characters in the resistance reading. An output strobe is also provided to allow synchronization of the resistance tester with the PLC. The BCD output is a TTL logic level of 0 to 5 VDC and a maximum output current of 24 mA.

### ***REMOTE RANGE SELECT ( RR ):***

The remote range select option is typically used in on-line testing when various resistances must be tested. This option allows a PLC or other controller on the production line to set the range of the resistance tester. This option is usually used in conjunction with the BCD or RS-232 options. In the new ‘X-series’ of the HebTech Testers the remote range selection is done through the RS-232 serial port. The serial port can also be used to externally set upper and lower limit sensors. This feature is most useful with the Test Channel Multiplex Option.

### ***SAMPLE and HOLD ( SH ):***

This option is available only in the Rack Mount –XR series ohmmeters because of space restrictions. It permits the measurement of a component’s resistance ‘on-the-fly’ even though the contact time with the component is very brief (a few milliseconds). It is possible to hold a resistance reading for digital processing and display. 100 % testing is possible under such conditions.

### ***SAFETY RELAY ( RY ):***

When a resistance tester is used in conjunction with high pot or surge tests, an internal safety relay can be provided to lock-out the resistance tester circuitry during other testing. This will protect the resistance tester from possible high-voltage or high-current damage. Due to space requirements, this is only available in the Rack Mount cases.

### ***RS-232 COMPUTER INTERFACE ( RS232 ):***

A three-wire link between the resistance tester and a computer can be made through the RS-232 port. This is a standard null-modem connection with a 9600-Baud rate, and a word length of 8 bits. The default Baud rate is set to 9600 at the factory. This permits the reading shown on the front panel display to be sent to an external computer or PLC, every time the instrument receives an ASCII from the host. This interface is useful for the statistical analysis of production, predictive control, and data logging. It is compatible with

any computer or PLC having an RS-232 port.

Factory settings for the Serial Port: 9600 Baud, No stop bit, 8 bit word, No parity. (9600,N,8,1) Program changes can permit operation up to 56K Baud on special order.

### **NULL MODEM CONNECTIONS:**

The RS-232 port is usually interfaced to a computer using terminal software and responds much like a dumb terminal. For the connecting cable use a MALE DB-9 style connector wired with the following pin configuration.

<b>Function</b>	<b>Connector Pin</b>
<i>Receive ( Rx )</i>	<i>Pin 2</i>
<i>Common ( Com )</i>	<i>Pin 5</i>
<i>Transmit ( Tx )</i>	<i>Pin 3</i>

Whenever the host computer sends any character to the RS-232 port, it will respond by returning the 5 characters plus the decimal shown in the display of the resistance tester. In the case of the Model 5050-06XP-Series resistance tester, which has only a four-digit display, a six-digit character group is still sent. The fifth digit is the least significant digit. After the five-character resistance reading is sent including the decimal point, the port will stand by, waiting to receive the next character from the computer before returning the current reading.

#### **NOTE:**

*The resistance tester does not send Start Of Text (0X02 Hex), End Of Text (0X03 Hex) or a Carriage Return (0X0D Hex). The unit simply stops sending data after the 5th digit. Special ASCII characters can be appended on a custom basis.*

# TEMPERATURE COMPENSATION PROCEDURE

## PRE-CALIBRATION PROCEDURE:

Plug the Temperature Compensation Probe into the jack located on the rear panel. Make a coil of copper wire, approximately one Ohm in resistance that will easily fit into your water bath containers. Make up a 4-wire Kelvin connection to the Standard coil and connect the 4 wires to the test jacks on the front panel of your Ohmmeter.

Using a Voltmeter, measure the voltage between the green and gray wires on the stereo jack located on the rear panel. The measured reading should be approximately 2.73 Volts +10 mV per C°. For example, the room temperature is 25°C. The voltage reading should be about 2.98 Volts. If the voltage reading is more than ±20 mV from the calculated reading or the reading is 12 V, then the TC probe is defective.

Replacement TC probes can be ordered from HebTech, LLC as part # -TCP.

### Note:

*TC probes are not interchangeable without re-calibration. Each Probe must be calibrated to work with its own HebTech Unit.*

## PREPARING THE WATER BATHS:

Three water baths will be needed for proper calibration: One bath at the specified STANDARD temperature; a HOT bath at +20°C from the specified temperature and a COLD bath at -20°C from the specified temperature. For example, if the specified temperature is 25 °C, using a Celsius thermometer prepare one bath for 25°C, a HOT bath at 45°C and a COLD bath (using ice cubes if necessary) at 5 °C. It is important that enough water is used in each bath so that room temperature will not effect the temperatures of the baths before the calibration is complete. Also make sure that the STANDARD bath is EXACTLY what the standard temperature should be.

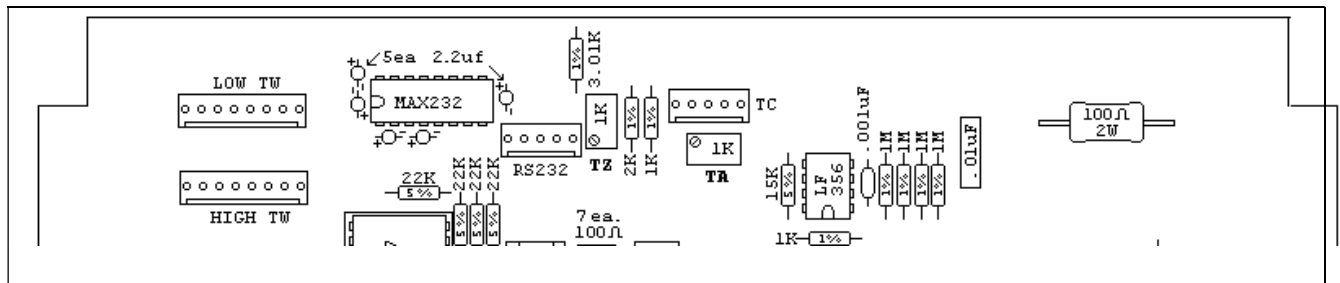

Location of Temp. Comp. Adjustments

**CALIBRATION PROCEDURE:**

- 1) Plug the temperature compensation probe into the rear of the resistance tester. Connect the 1- Ohm Standard coil to either the MS-connector or the Front Panel Test terminals using a 4-wire Kelvin connection.
- 2) Set the resistance tester to the 2-Ohm range. Make sure the temperature compensation switch located on the rear panel is in the OFF (center) position.
- 3) Place the TC probe and the resistance standard into the specified temperature bath. "Stir" the TC probe and the resistance standard a few times until the readings stabilize. After the display stabilizes (usually a few minutes) record the coil resistance reading.

**Step #3 Reading** \_\_\_\_\_

- 4) Switch the temperature compensation switch to the **ON** position.
- 5) Adjust the **TZ** Potentiometer until the display reads the same as the recorded reading in Step #3. Place the TC probe and the resistance standard into the HOT bath. "Stir" the TC probe and the resistance standard a few times until the display stabilizes (usually a few minutes), adjust POT **TA** until the display reads the same as the recorded reading in Step #3.
- 6) Place the TC probe and the one Ohm standard coil into the COLD bath. "Stir" the TC probe and the coil standard a few times until the display stabilizes.

**Step #6 Reading** \_\_\_\_\_

- 7) Subtract the reading from Step #6 from the recorded reading in Step #3. Divide the ANSWER by 2. Add this result to the original reading in Step #7, and record the result.

<b>Step #3 reading</b> _____	<b>Answer/2 =</b> _____
<b>Step #6 reading</b> _____	<b>+ Step #6 +</b> _____
<b>Answer =</b> _____	<b>Step #7 result</b> _____

- 8) Adjust potentiometer **TA** until the display reads the same as the recorded result in Step #7
- 9) Turn the temperature compensation switch to the OFF position. The temperature compensation procedure is completed.

## TROUBLE-SHOOTING HINTS

### SYMPTOM:

The Resistance Testers' display flashes "0000".

### POSSIBLE SOLUTIONS:

- The Resistance Tester is in over-range mode, select a higher range.
- The ICL7135 CPI A/D converter could be burned-out. This IC is socketed and can easily be replaced by the user<sup>1</sup>.

### SYMPTOM:

The Resistance Tester displays changing numbers or "garbage" readings.

### POSSIBLE SOLUTIONS:

- Check to make sure a "load" is connected to the Resistance Tester via the back panel circular connector or front panel banana plugs. While the Kelvin Connection is open circuit (I+ not connected to E+ and I<sub>-</sub> not connected to E-) the voltage present on the Voltage input terminals will be random. Because there is a small capacitor on the input circuit, you will display any static charge that has accumulated on this capacitor. This is the normal behavior of a Kelvin input instrument.
- Check to make sure you have a valid 4 wire Kelvin connection. (see illustration below)

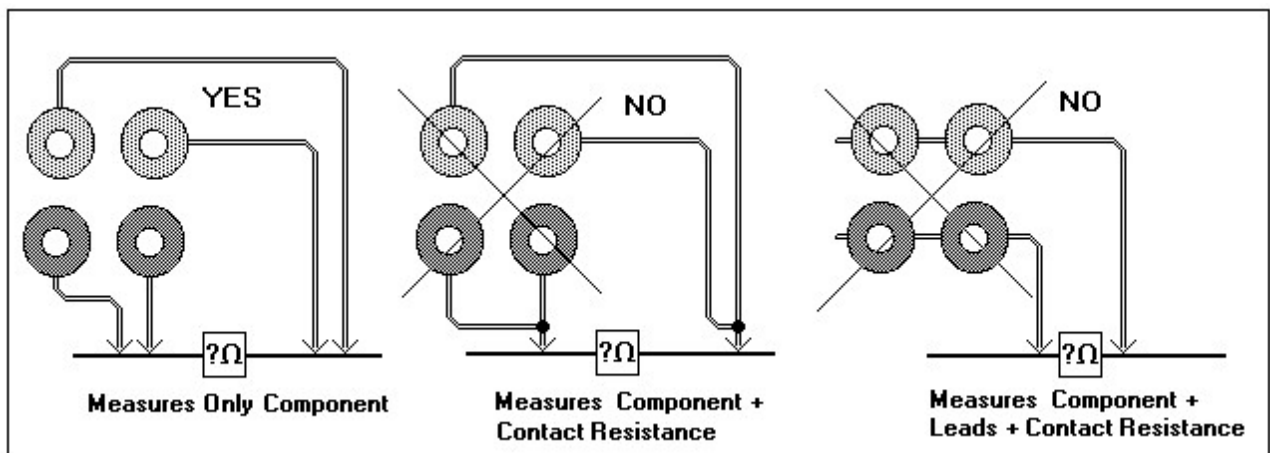

### SYMPTOM:

Readings all appear to be incorrect.

<sup>1</sup> Opening the meter to replace any IC's could void the manufacturer's warranty.

## POSSIBLE SOLUTIONS:

- Check to see if the Temperature Compensation switch is in the proper position and that the TC probe is completely inserted into the rear panel Jack. Is the Resistance Tester due for calibration? A calibration should be performed once a year.
- Insure that the front panel I and E terminals are not connected to permit a 2-wire non-Kelvin test. Although the meter accuracy will be OK on the higher ranges, this will cause severe errors on the lower resistance ranges. This will be a problem even if you are using the MS-Style connector for you Kelvin Leads.
- Using the 4-wire test leads but connecting them to only two 'pogo' pins will leave the 'pogo pin' resistance and the contact resistance in the measurement. Four individual connections must be made to the test component's terminals to get a real Kelvin connection.
- One or more of the OP177 op-amps could be burned-out. These IC's are socketed and can easily be replaced by the user<sup>1</sup>.
- Check to make sure you have a true 4-wire Kelvin connection.

### NOTE:

*Resistance changes as temperature changes. If the ambient temperature varies during the day so will the resistance of the part under test. This could make it appear that the Resistance Tester is not working properly. You may require the use of Temperature Compensation.*

**For Technical assistance call HebTech, LLC at (740) 957-4979**

## RETURN POLICY

### NOTE:

*Before returning a Resistance Tester for repair or calibration you must **first** call or email [service@hebtechnology.com](mailto:service@hebtechnology.com) and receive an RMA#. Any package received without an RMA# will be returned to shipper. Please write the RMA# on the package and packing slip.*

**To return a Resistance Tester for repair after you receive an RMA# ship to:**

**HebTech, LLC  
78 Scottwood Court  
Delaware, Ohio 43015  
Phone: (740) 957-4979  
[www.hebtechnology.com](http://www.hebtechnology.com)**

# MANUFACTURER'S WARRANTY

Equipment shall meet all engineering performance data and design requirements described in the specifications. Within a period of one year from the date of shipment, if the equipment should fail to function due to a defect in parts or workmanship, HebTech, LLC, at its option, will replace or repair the equipment at its facility in Delaware, Ohio.

### NOTE:

*Removing the calibration seal and performing unauthorized repairs will void the calibration and could void the manufacturer's warranty. Please call HebTech, LLC before performing any repairs.*

## MODEL 5050-06XP MAIN PCB ASSEMBLY DRAWING

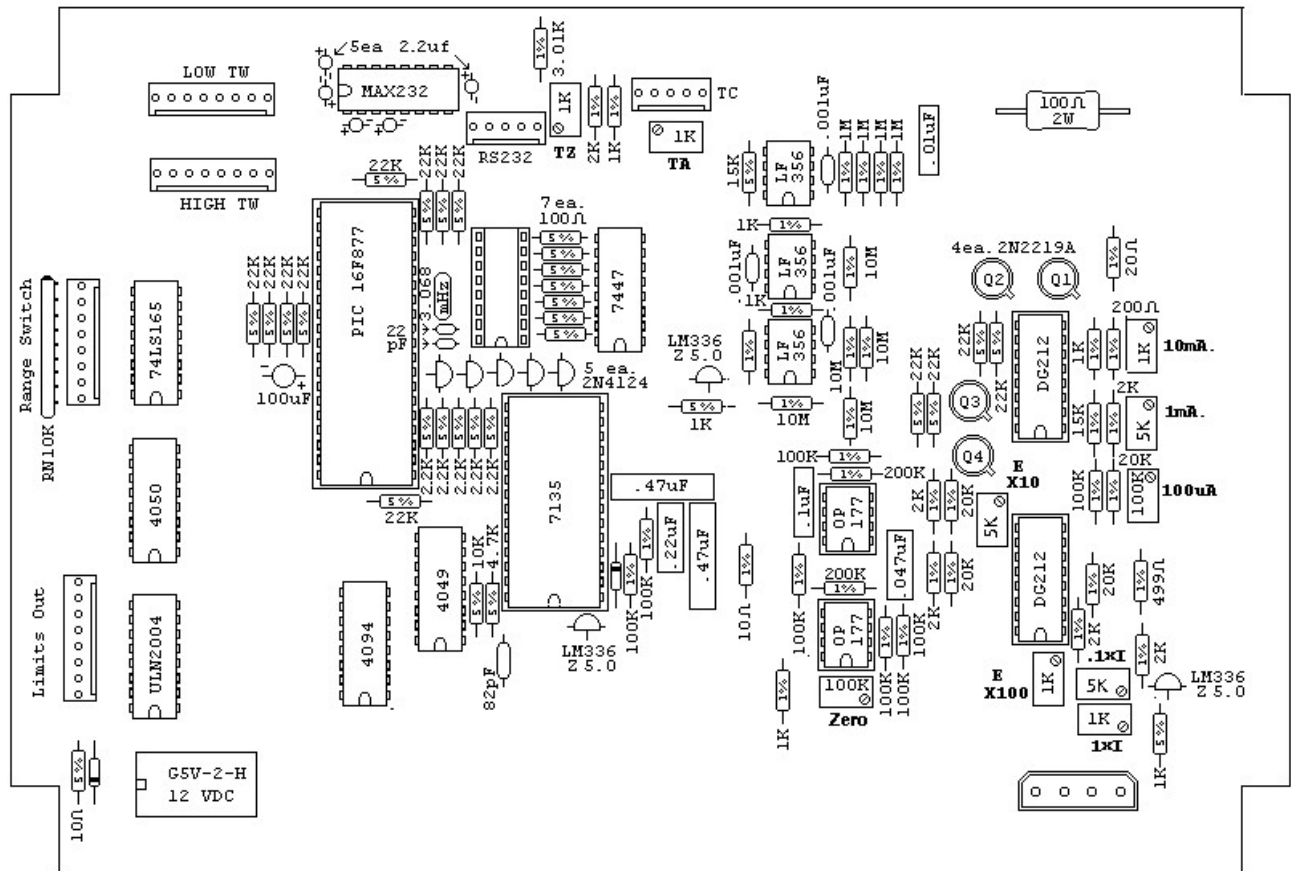

# 5050-06XP-Series Display Board

