

HARRIS INSTRUMENT

INDUSTRIAL
RESISTANCE TEST
EQUIPMENT

Model 5012-05A Limit-Sensing Resistance Tester



Operators Manual

Harris Instrument Corporation
Limit-Sensing Resistance Tester – Model 5012-05A

| | |
|------------------------------------|----|
| Equipment Configuration | 2 |
| Specifications & Dimensions | 3 |
| Theory of Operation | 4 |
| Operation of Unit | 5 |
| Calibration Procedure | 7 |
| Options | 9 |
| RS-232 Configuration | 11 |
| BCD Configuration | 13 |
| Remote Range Configuration | 13 |
| Temperature Compensation Procedure | 14 |
| Trouble Shooting Hints | 17 |
| Return Policy | 18 |
| Warranty | 18 |
| Spare Parts List | 19 |
| Assembly Drawings | 20 |

EQUIPMENT CONFIGURATION:

Resistance Tester Model 5012-05A, serial number _____, is equipped with the following options as indicated.

- _____ Temperature Compensation at _____ for _____
- _____ RS-232 Computer Interface
- _____ Binary Coded Decimal Computer Interface
- _____ Remote Range Select
- _____ Sample and Hold
- _____ Safety Relay
- _____ High Current
- _____ Low Current
- _____ 230 VAC Service
- _____ Diode Polarity Test
- _____ Foot Switch
- _____ Buzzer
- _____ Other _____

SPECIFICATIONS

| | |
|--------------------------------|---|
| <i>ACCURACY (% FULL SCALE)</i> | <i>±0.05% (Includes +/- 1 digit) at 25 ° C</i> <i>±0.001% per ° C from 0 to 70 ° C</i> |
| <i>RANGES</i> | <i>0 to 1.999, 19.99, 199.9, 1.999K, 19.99K Ohms</i> |
| <i>DISPLAY</i> | <i>3 1/2 digit LED</i> |
| <i>READING RATE</i> | <i>4 readings per second (minimum)</i> |
| <i>TERMINALS</i> | <i>Max. Full-scale voltage is 2.0 Volts and less than 100 ma. Current</i> |
| <i>POWER REQUIREMENTS</i> | <i>117 VAC +/- 10 %, 50-60 Hz, 5 Watts. 2 amp Slo-Blo fuse (230 VAC optional)</i> |
| <i>TEST CONNECTIONS</i> | <i>4 wire Kelvin required</i> |
| <i>CONNECTORS</i> | <i>Rear panel MS-style circular connector and front panel banana jacks</i> |
| <i>LIMIT ALARM TERMINALS</i> | <i>Dry contacts rated at 5A. At 117 VAC</i> |

DIMENSIONS

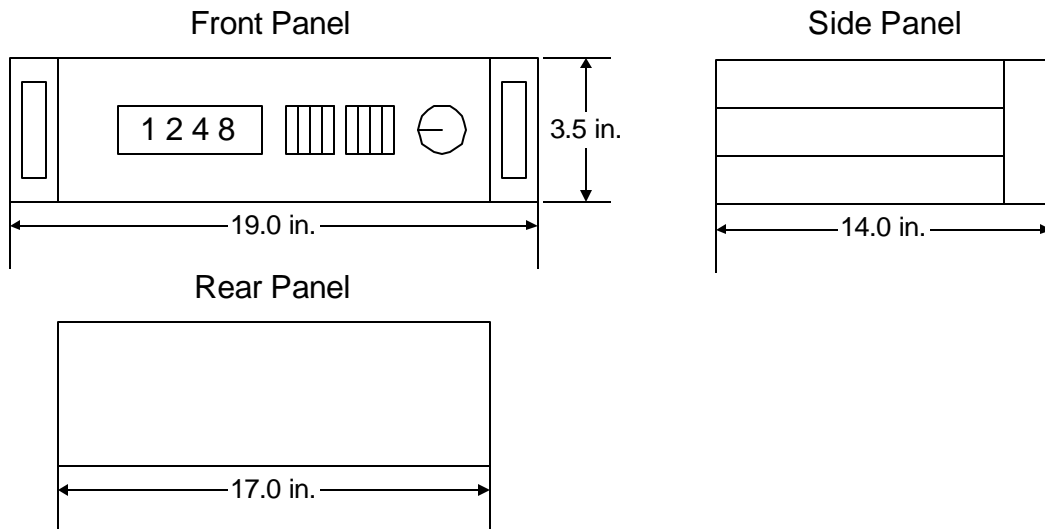

THEORY of OPERATION

The Harris Instrument Corporation Model 5012-05A Resistance Tester is a digital ohmmeter that includes a precision constant current source which drives a known current through an unknown resistance. It features four readings per second and a temperature compensated voltage reference serving both the DVM and the constant current source. This results in a stable calibration reference. A digital voltmeter measures the potential across the resistance and presents a digital display of the resistance in Ohms.

CMOS circuit construction includes a dual limit comparator which compares the measured resistance with upper and lower tolerance values entered on front panel thumbwheels. Red and green front panel lights indicate whether or not the resistance is within tolerance. An output relay permits the resistance tester to be converted to a rejection device. For “fail-safe” operation the contacts are normally open. The contacts close if the part is within tolerance.

BLOCK DIAGRAM

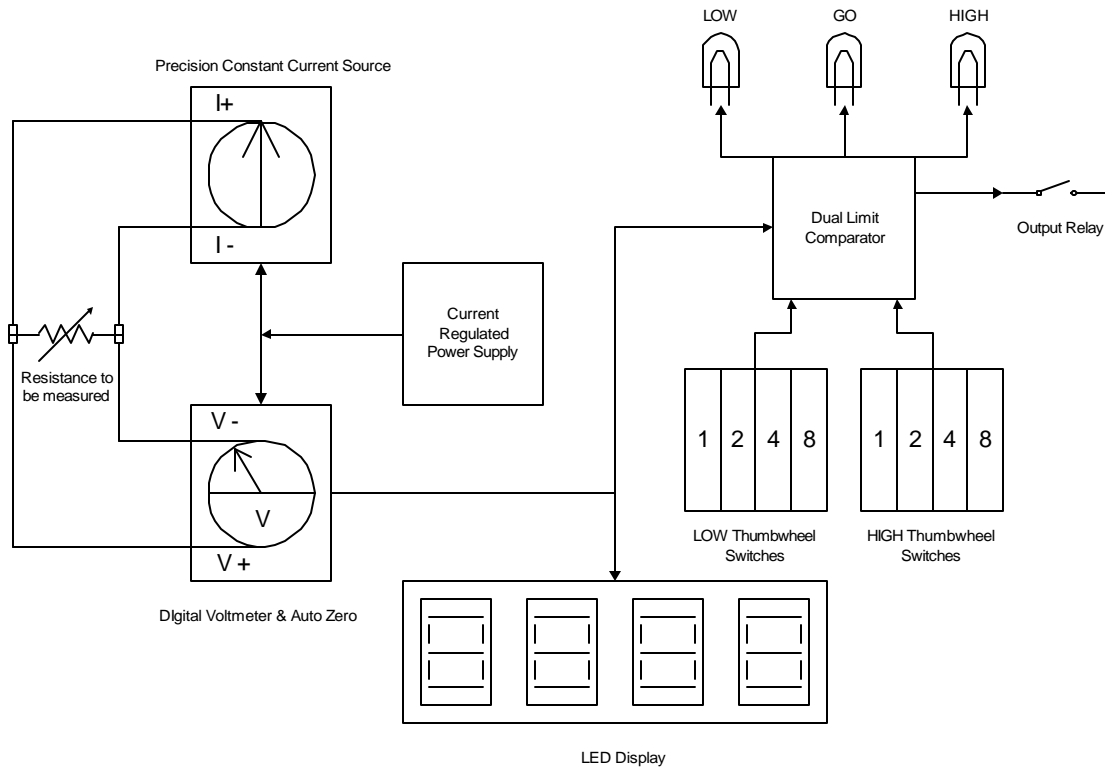

OPERATION of UNIT

FRONT PANEL VIEW:

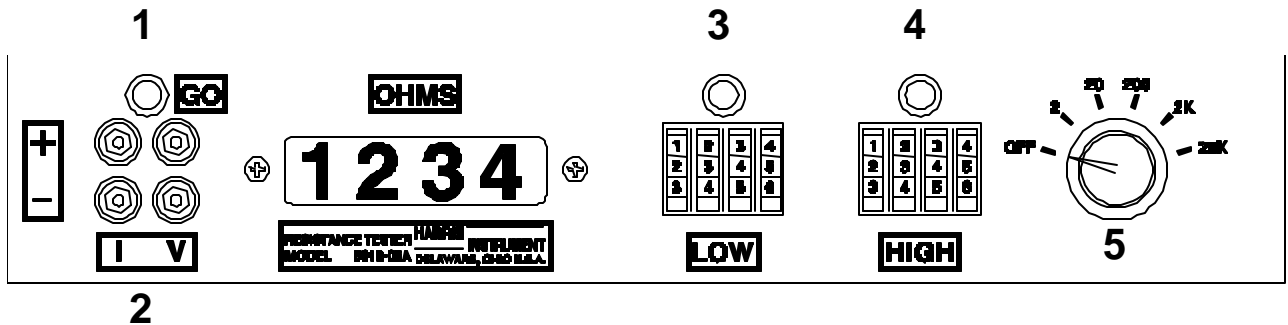

- 1) Green light indicates that the part under test is within tolerance.
- 2) Front panel banana jacks allows a 4-wire Kelvin connection to be made.
- 3) Select LOW limit. Red light located above LOW limit thumbwheel switches indicates that the part under test is below tolerance.
- 4) Select HIGH limit. Red light located above HIGH limit thumbwheel switches indicates that the part under test is above tolerance.
- 5) Range select knob. Rotate to correct range.

Resistance of the part under test appears on the LED display. A flashing “0000” display indicates that the RANGE SELECTOR (5) is set *lower* than the resistance being measured.

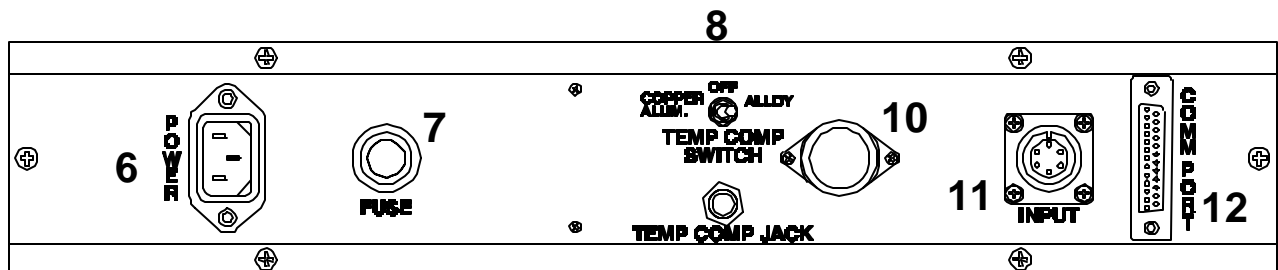

REAR PANEL VIEW:

- 6) Power cord. Connect to 117 VAC 50-60 Hz. Optional 230 VAC operation available.
- 7) Fuse holder. Use a 2 Amp Slo-Blo Fuse.
- 8) Temperature compensation switch.¹ Center position is OFF.
- 9) Temperature compensation jack for Harris Instrument Corporation temperature probe (TC Probe).²
- 10) LM340 KC-5 regulator transistor.
- 11) 6-pin female MS-style circular connector.³

¹ Optional equipment.

² Optional equipment. Order MA1061 for replacement TC probe.

5012 Manual.DOC

07/19/00

Digital Resistance Tester – Model 5012-05A
Operators Manual

12) 25-pin female DB-style connector, for use with RS-232 and BCD.⁴

TEST CONNECTIONS:

NOTE:

For greatest accuracy each voltage and current lead must connect separately to the component under test.

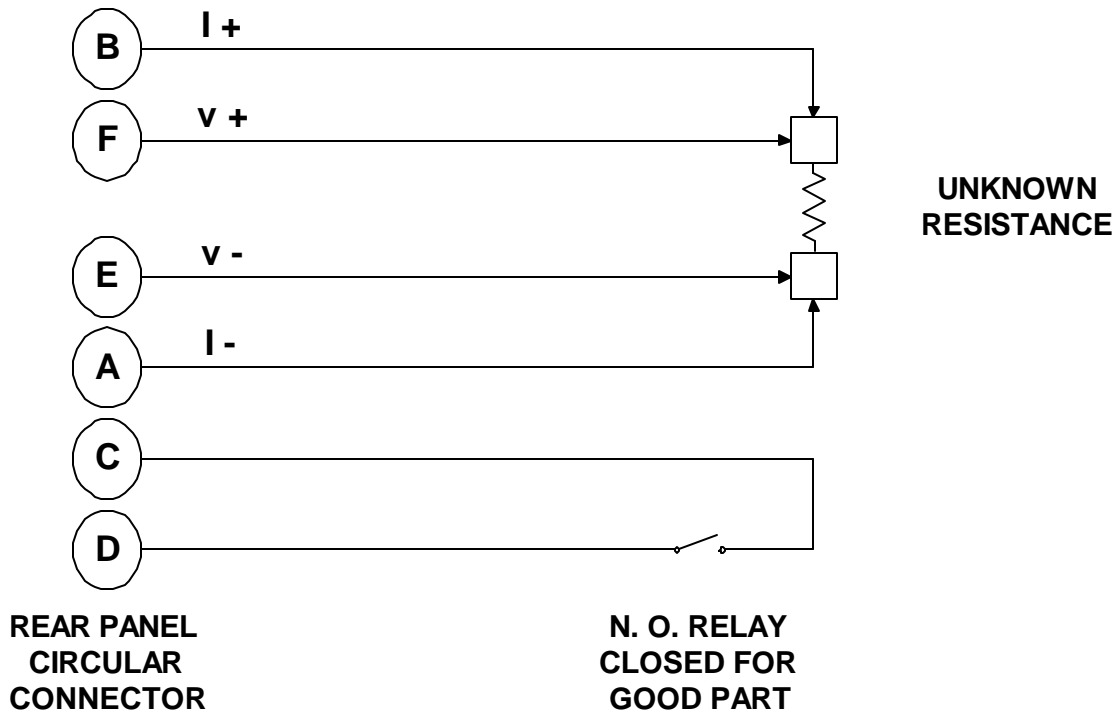
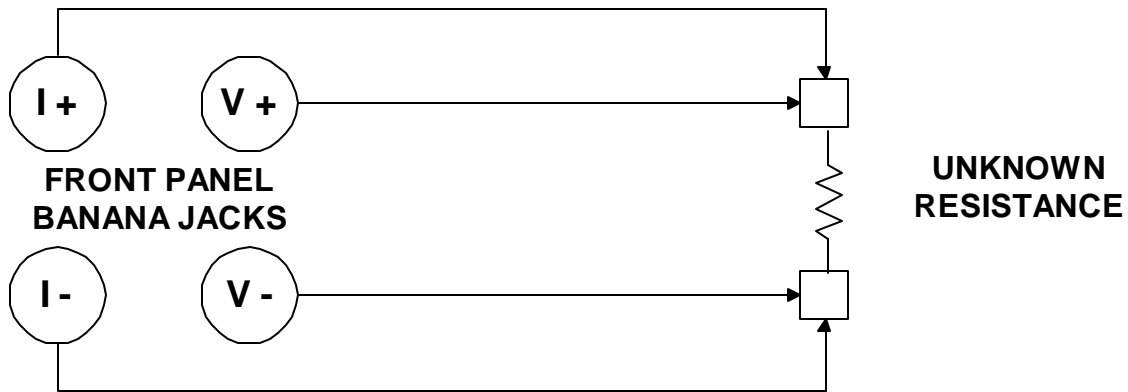

³ Mating connector for rear panel connection is available from Harris Instrument, part # 97.

⁴ Optional equipment

5012-05A CALIBRATION PROCEDURE

REQUIRED EQUIPMENT:

- A. A digital voltmeter / milliammeter with a 4½ digit resolution is required. A Fluke® Model 8050A is suitable.
- B. A set of five standard resistances, one for each range to be calibrated. A precision of at least 0.02% is necessary to calibrate this instrument to specifications. Harris Instrument Corporation can supply a 0.02% resistance set, Model 2005, with standard resistances and switchable Kelvin connections.

Recommended standard resistance

1.9990 Ohms
19.990 Ohms
199.90 Ohms
1999.0 Ohms
19990 Ohms

NOTE:

The resistances must be just below the full scale value of each range.

- C. A set of test leads for a four wire Kelvin connection between the resistance standards and the resistance tester.

PRE-CALIBRATION PROCEDURE:

Before undertaking a complete calibration, it is advisable to check each range using standard resistors at full scale and 1/10th full scale. Analysis of any deviation from specifications could make calibration much simpler. If steps A, B, and C do not bring the resistance tester into specification then proceed through all steps starting with step 1.

- A. If all ranges are off slightly at full scale, but are still accurate at the low end of their ranges, the D to A converter span adjustment needs minor adjustment. See step 8.
- B. If all ranges are off slightly at both the top and bottom of their ranges, the D to A converter zero adjustment needs adjustment. See step 6.
- C. If only one range is out of calibration, with the worst errors near full scale, the individual range current source needs adjustment.

| <u>For the range:</u> | <u>Go to step:</u> |
|-----------------------|--------------------|
| 20K Ohms | 7 |
| 2K Ohms | 5 |
| 200 Ohms | 9 |
| 20 Ohms | 10 |
| 2 Ohms | 11 |

NOTE:

Actual certified resistance may be other than 19990. The display should be set to read the actual certified resistance of each standard value when using this procedure.

- 1) Connect the 1999.0 Ohm standard to the Model 5012-05A binding posts or rear panel MS-style circular connector using the Kelvin test leads.
- 2) Set the voltmeter to the 200 mV range and connect the voltmeter to measure the voltage across the standard resistor.
- 3) Adjust the “2 K” potentiometer for a minimum reading on the voltmeter.
- 4) Adjust the “R” potentiometer until the voltmeter displays a value of 199.70 mV \pm 10 mV.
- 5) Adjust the “2 K” potentiometer until the voltmeter displays a value of 199.90 mV. Disconnect the voltmeter leads from the resistance standard.
- 6) Remove the standard resistor and short all four Kelvin lead connections together for a zero ohm standard. Select the 200 ohm range on the Model 5012-05A and adjust the “zero” potentiometer until “000.0” is displayed.
- 7) Connect the 19990 ohm standard to the Model 5012-05A. Select the 20K ohm range, and adjust the “FS” potentiometer until a reading of “1999” is displayed.
- 8) Connect the 1999.0 ohm standard to the Model 5012-05A. Select the 2K ohm range, and adjust the “10 X” potentiometer until a reading of “1999” is displayed.
- 9) Connect the 199.90 ohm standard to the Model 5012-05A. Select the 200 ohm range, and adjust the “200” potentiometer until a reading of “199.9” is displayed.
- 10) Connect the 19.990 ohm standard to the Model 5012-05A. Select the 20 ohm range, and adjust the “20” potentiometer until a reading of “19.99” is displayed.
- 11) Connect the 1.9990 ohm standard to the Model 5012-05A. Select the 2 ohm range, and adjust the “2” potentiometer until a reading of “1.999” is displayed.

Model 5012-05A calibration procedure is completed.

OPTIONS

TEMPERATURE COMPENSATION (TC):

Temperature changes of a few degrees in a product can have significant effects on the product's resistance. Therefore, the need for temperature compensation may arise when the temperature of the part being tested changes over a period of time.

The benefits of temperature compensation include the saving of time, energy, and money by eliminating the need to refer to coefficient tables as the ambient plant temperature varies during the day. Before now, such compensation was available only in expensive and delicate laboratory-grade instruments. Harris Instrument has now made it available in rugged resistance testers designed for use in production.

With temperature compensation, a probe sends ambient temperature data to the instrument. This temperature information is used to modify the constant current that is being passed through the part under test. The resistance then registered is the resistance the item under test would have at the specified temperature. The compensation option can be calibrated for the measurement of either of two measurement coefficients or it can be operated without any compensation. The accuracy of the compensation is within 0.2 % of the actual resistance between 0 and 50 ° C.

RS-232 COMPUTER INTERFACE (RS232):

A three wire link between the resistance tester and a computer can be made through the RS-232 port. This is a standard null-modem connection with an adjustable baud rate (50 - 19,200) and word length of 7 or 8 bit. This permits the reading shown on the front panel display to be sent to the computer at the set baud rate every time the instrument is sent a character by the computer. This interface is useful for the statistical analysis of production, predictive control, and data logging. It is compatible with any computer having an RS-232 port and any terminal program.

Factory settings: 9600 Baud, No stop bit, 7 bit word, No parity. (9600,N,7,1)

BINARY CODED DECIMAL (BCD):

The BCD output allows the resistance tester to transmit readings to a Programmable Logic Controller (PLC). The BCD option generates a 1, 2, 4, and 8 bit for each of the 5 characters in the resistance reading. An output strobe is also provided to allow synchronization of the resistance tester with the PLC. The BCD output is a TTL logic level of 0 to 5 VDC and a maximum output current of 24 mA.

REMOTE RANGE SELECT (RR):

The remote range select option is typically used in on-line testing when various resistances must be tested. This option allows a PLC or other controller on the production line to set the range of the resistance tester. This option is usually used in conjunction with the BCD or RS-232 options.

SAMPLE and HOLD (SH):

This option permits the measurement of a component's resistance 'on-the-fly' even though the contact time with the component is very brief (a few milliseconds). It is possible to hold a resistance reading for digital processing and display. 100 % testing is possible under such conditions.

SAFETY RELAY (RY):

When a resistance tester is used in conjunction with high pot or surge tests, an internal safety relay can be provided to lock-out the resistance tester circuitry during other testing. This will protect the resistance tester from possible high-voltage or high-current damage.

HIGH CURRENT (HC):

Some materials require the application of a higher current to insure accurate resistance measurement. This is often true when products having low resistance values are being tested. This option increases the maximum current to a level of 1 amp.

LOW CURRENT (LC):

Traditionally, a very low resistance is measured by passing a very high current through a device and measuring the voltage drop across the device. However, in some applications it is necessary to measure resistance with a very low current to prevent damage to the item being tested. Photo flash bulbs, fuses, and electronically-actuated explosives are examples of items which may be damaged by the current ordinarily required to measure the low resistance.

Optional use of a solid state, chopper-stabilized pre-amplifier allows full-scale, non-destructive resistance testing with only 2 millivolts across the tested resistance. The combination of this low current option with the four-terminal resistance measuring system permits accurate measurement of very low resistance without risk of damage to the product.

RS-232 CONFIGURATION

The RS-232 option supplied with your Harris Instrument Resistance Tester will permit you to automatically enter resistance measurement data into a computer for statistical analysis or process control. Refer to assembly drawing of PCB 92028B on Pg. 21 for locations of jumper headers.

BAUD:

The RS-232 port baud rate is set to 9600 at the factory. It may be adjusted with the internal jumper headers to whatever baud rate is most convenient, from 50 to 19,200 baud. See table below for the proper jumper settings.

| Jumper Settings (1 2 3 4) | Baud Rate | Jumper Settings (1 2 3 4) | Baud Rate |
|--------------------------------|--------------|--------------------------------|--------------|
| 0 0 0 0 | 50 | 1 0 0 0 | 1800 |
| 0 0 0 1 | 75 | 1 0 0 1 | 2000 |
| 0 0 1 0 | 110 | 1 0 1 0 | 2400 |
| 0 0 1 1 | 134.5 | 1 0 1 1 | 3600 |
| 0 1 0 0 | 150 | 1 1 0 0 | 4800 |
| 0 1 0 1 | 300 | 1 1 0 1 | 7200 |
| 0 1 1 0 | 600 | 1 1 1 0 | 9600 |
| 0 1 1 1 | 1200 | 1 1 1 1 | 19200 |

0 = No Jumper, 1 = Jumper Installed

Common Configurations:

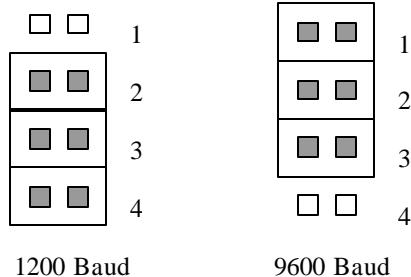

WORD LENGTH:

The word length is set to 7 Bit at the factory. The word length is also adjustable for 7 or 8 bit via a jumper header. Jumper the left most header and the center header for 8 bit word length. Jumper the right most header and the center header for 7 bit word length.



INTERNAL / EXTERNAL:

The RS-232 port can be set for internal or external use. With the board jumped for internal use, the unit will respond to any RS-232 input with a 5 character output. In external use, a foot switch or other contact closure

is required to prompt the RS-232 for a 5 character output. The RS-232 port is set for internal use at the factory.



PARITY and DUPLEX:

The parity is set to NONE and duplex is set to HALF. Parity and Duplex parameters are hard wired and will require circuit modification to change.

NULL MODEM CONNECTIONS:

The RS-232 port is usually interfaced to a computer using terminal software and responds much like a dumb terminal. For the connecting cable use a MALE DB-25 style connector wired with the following pin configuration.

| Function | Wire Color | Connector Pin |
|-----------------|---------------|---------------|
| Receive (Rx) | Blue / White | Pin 2 |
| Common (Com) | Gray | Pin 1 & Pin 7 |
| Transmit (Tx) | Green / White | Pin 3 |

Whenever the host computer sends any character to the RS-232 port, it will respond by returning the 5 characters in the digital display of the resistance tester. In the case of the 5012-05A resistance tester, which has only a four digit display, a five digit character group is still sent. The fifth digit is the least significant digit. After the five character resistance reading is sent, the port will stand by, waiting to receive a character from the computer before returning the next reading.

NOTE:

The resistance tester does not send Start Of Text (0X02 Hex), End Of Text (0X03 Hex) or a Carriage Return (0X0D Hex). The unit simply stops sending data after the 5th digit.

BCD OUTPUT and REMOTE RANGE SELECT CONFIGURATION:

The BCD and Remote Range Select options are supplied with a FEMALE DB-25 style connector located on the rear panel with the following connections.

| Pin Number | Data | Explanation |
|------------|-------------------|--------------------------------|
| 1 | 1 | <i>MSD</i> |
| 2 | 2 | |
| 3 | 1 | |
| 4 | 2 | <i>2nd</i> |
| 5 | 4 | <i>Digit</i> |
| 6 | 8 | |
| 7 | 1 | |
| 8 | 2 | <i>3rd</i> |
| 9 | 4 | <i>Digit</i> |
| 10 | 8 | |
| 11 | 1 | |
| 12 | 2 | <i>4th</i> |
| 13 | 4 | <i>Digit</i> |
| 14 | 8 | |
| 15 | 1 | <i>LSD</i> |
| 16 | 2 | |
| 17 | 4 | |
| 18 | 8 | |
| 19 | <i>Range #5</i> | <i>Highest Range (Default)</i> |
| 20 | <i>Range #4</i> | |
| 21 | <i>Range #3</i> | |
| 22 | <i>Range #2</i> | |
| 23 | <i>Range #1</i> | <i>Lowest Range</i> |
| 24 | <i>Data Ready</i> | |
| 25 | <i>Common</i> | |

Pins 1 through 18 are TTL-buffered BCD data output from a 74LS244 buffer. Data common is available at Pin 25. Pins 19 through 23 are range selector pins. Ranges are selected by connecting these pins one at a time to common (Pin 25). If no range is selected, the unit will default to the highest range (20 K). Data is valid only while the Data Ready pulse on Pin 24 is high. This pulse has a 10 % duty cycle. Data taken at any other time may be invalid because digits are strobed sequentially.

TEMPERATURE COMPENSATION PROCEDURE

PRE-CALIBRATION PROCEDURE:

Plug the Temperature Compensation Probe into the stereo jack located on the rear panel.

Using a Voltmeter, measure the voltage between the green and gray wires on the stereo jack located on the rear panel. The measured reading should be approximately 2.73 Volts +10 mV per C°. For example, the room temperature is 25°C. The voltage reading should be about 2.98 Volts. If the voltage reading is more than ±20 mV from the calculated reading or the reading is 12 V, then the TC probe is defective. Replacement TC probes can be ordered from Harris Instrument Corp. as part # MA1061.

Note:

TC probes are not interchangeable without re-calibration.

PREPARING THE WATER BATHS:

Three water baths will be needed for proper calibration. One bath at the SPECIFIED temperature, a HOT bath at +20°C from the specified temperature and a COLD bath at -20°C from the specified temperature. For example, the specified temperature is 25°C. Using a Celsius thermometer prepare one bath for 25°C, a HOT bath at 45°C and a COLD bath (using ice cubes if necessary) at 5°C. It is important that enough water is used in each bath so that room temperature will not effect the temperatures of the baths before the calibration is complete. Also make sure that the specified bath is EXACTLY what the temperature should be.

Temperature Compensation PC Board

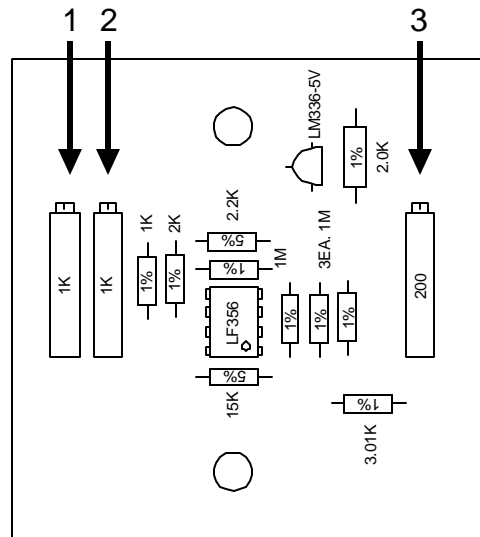

CALIBRATION PROCEDURE:

- 1) Plug the temperature compensation probe and the resistance standard⁵ into the rear of the resistance tester.
- 2) Set the resistance tester to the lowest range. Make sure the temperature compensation switch located on the rear panel is in the OFF (center) position.
- 3) Place the TC probe and the resistance standard into the specified temperature bath. “Stir” the TC probe and the resistance standard a few times until the readings stabilize. After the display stabilizes (usually a few minutes) record the reading.

Step #3 Reading _____

- 4) Switch the temperature compensation switch to the Cu/Al (right) position.
- 5) Adjust POT #3 until the display reads the same as the recorded reading in Step #3. Switch the temperature compensation switch to the Alloy (left) position. Adjust POT #3 until the display reads the same as the recorded reading in Step #3. Make sure no change occurs when switching through all three positions of the temperature compensation switch. Return the temperature compensation switch to the Cu/Al position before proceeding.
- 6) Place the TC probe and the resistance standard into the HOT bath. “Stir” the TC probe and the resistance standard a few times until the display stabilizes. After the display stabilizes (usually a few minutes), adjust POT #1 until the display reads the same as the recorded reading in Step #3.
- 7) Place the TC probe and the resistance standard into the specified temperature bath. After a few minutes, place the TC probe and the resistance standard into the COLD bath. “Stir” the TC probe and the resistance standard a few times until the display stabilizes. Record the reading.

Step #6 Reading _____

- 8) Subtract the reading from Step #6 from the recorded reading in Step #3. Divide the ANSWER by 2. Add this result to the original reading in Step #6, and record the result.

| | | | |
|--------------------------|-------|-----------------------|---------|
| Step #3 reading | _____ | Answer / 2 = | _____ |
| Step #6 reading - | _____ | + Step #6 | + _____ |
| Answer = | _____ | Step #7 result | _____ |

- 9) Adjust POT #1 until the display reads the same as the recorded result in Step #7.
- 10) Switch the temperature compensation switch to the OFF position. Record the displayed reading.

Step #9 Reading _____

- 11) Subtract the reading from Step #9 from the recorded reading in Step #3. Divide the ANSWER by 2. Add this result to the original reading in Step #9, and record the result.

| | | | |
|--------------------------|-------|---------------------|---------|
| Step #3 reading | _____ | Answer / 2 = | _____ |
| Step #9 reading - | _____ | + Step #9 | + _____ |

⁵ Resistance standard: A coil of the product being tested, usually copper, of a known resistance that can be measured on the lowest range of the resistance tester.

Answer = _____ Step #10 result _____

- 12)** Switch the temperature compensation switch to the Alloy position and adjust POT #2 until the display reads the same as the recorded result in Step #10.
- 13)** Turn the temperature compensation switch to the OFF position. The temperature compensation procedure is completed.

TROUBLE-SHOOTING HINTS

SYMPTOM:

The Resistance Testers' display flashes "0000".

POSSIBLE SOLUTIONS:

The Resistance Tester is in over-range mode, select a higher range.

The ICL7135 CPI A/D converter could be burned-out. This IC is socketed and can easily be replaced by the user⁶.

SYMPTOM:

The Resistance Tester displays changing numbers or "garbage" readings.

POSSIBLE SOLUTIONS:

Check to make sure a "load" is connected to the Resistance Tester via the back panel circular connector or front panel banana plugs.

Check to make sure you have a true 4 wire Kelvin connection.

SYMPTOM:

Readings appear to be incorrect.

POSSIBLE SOLUTIONS:

Check to see if the Resistance Tester is due for calibration. A calibration should be performed once a year.

One or more of the MAX400 op-amps could be burned-out. These IC's are socketed and can easily be replaced by the user¹.

Check to make sure you have a true 4 wire Kelvin connection.

NOTE:

Resistance changes as temperature changes. If the ambient temperature varies during the day so will the resistance of the part under test. This could make it appear that the Resistance Tester is not working properly. You may require the use of Temperature Compensation.

For Technical assistance call Harris Instrument Corp., Resistance Tester Division at (740) 369-3580.

⁶ Opening the meter to replace any IC's could void the manufacturers warranty.
5012 Manual.DOC
07/19/00
Digital Resistance Tester – Model 5012-05A
Operators Manual

RETURN POLICY

NOTE:

*Before returning a Resistance Tester for repair or calibration you must **first** call and receive an RMA#. Any package received without an RMA# will be returned to shipper. Please write the RMA# on the package and packing slip.*

To return a Resistance Tester for repair after you receive an RMA# ship to:

**Harris Instrument Corporation
Resistance Tester Service Department
155 Johnson Drive
Delaware, Ohio 43015
Phone: (740) 369-3580
Fax: (740) 369-2653**

MANUFACTURERS WARRANTY

Equipment shall meet all engineering performance data and design requirements described in the specifications. Within a period of one year from the date of shipment, if the equipment should fail to function due to a defect in parts or workmanship, Harris Instrument Corp., at its option, will replace or repair the equipment at its facility in Delaware, Ohio.

NOTE:

Removing the calibration seal and performing unauthorized repairs will void the calibration and could void the manufacturers warranty. Please call Harris Instrument Corporation before performing any repairs.

SPARE PARTS LIST FOR DIGITAL RESISTANCE TESTER MODEL 5012-05A

| MANUFACTURER | STOCK NUMBER | PRICE |
|--------------------------|-------------------------------|----------|
| <i>Eldema</i> | <i>CF03-RTS-2102 (Red)*</i> | \$ 8.95 |
| <i>Eldema</i> | <i>CF03-GTS-2102 (Green)*</i> | \$ 8.95 |
| <i>Harris Instrument</i> | <i>MA1061 TC Probe</i> | \$ 50.00 |
| <i>Intersil</i> | <i>ICL 7135 CPI *</i> | \$ 22.50 |
| <i>Maxim</i> | <i>MAX 400 CPA *</i> | \$ 18.00 |
| <i>Motorola</i> | <i>7447</i> | \$ 2.60 |
| <i>National</i> | <i>LF 356 N</i> | \$ 3.60 |
| <i>National</i> | <i>LM 320 T-12 (7912)</i> | \$ 5.10 |
| <i>National</i> | <i>LM 340 T-12 (7812)</i> | \$ 3.75 |
| <i>National</i> | <i>LM 340 KC-5 (7805)</i> | \$ 6.30 |
| <i>National</i> | <i>LM 3999Z</i> | \$ 6.60 |
| <i>National</i> | <i>74C85 N</i> | \$ 5.00 |
| <i>National</i> | <i>75491</i> | \$ 2.40 |
| <i>RCA</i> | <i>4011</i> | \$ 0.80 |
| <i>RCA</i> | <i>4013</i> | \$ 1.90 |
| <i>RCA</i> | <i>4016</i> | \$ 1.90 |
| <i>RCA</i> | <i>4042</i> | \$ 2.70 |

* These parts are plug-in components, easily replaced by the user.

NOTE:

Prices are subject to change without notice. Minimum billing for spare parts order is \$50.00

MODEL 5012-05A MAIN PCB ASSEMBLY DRAWING

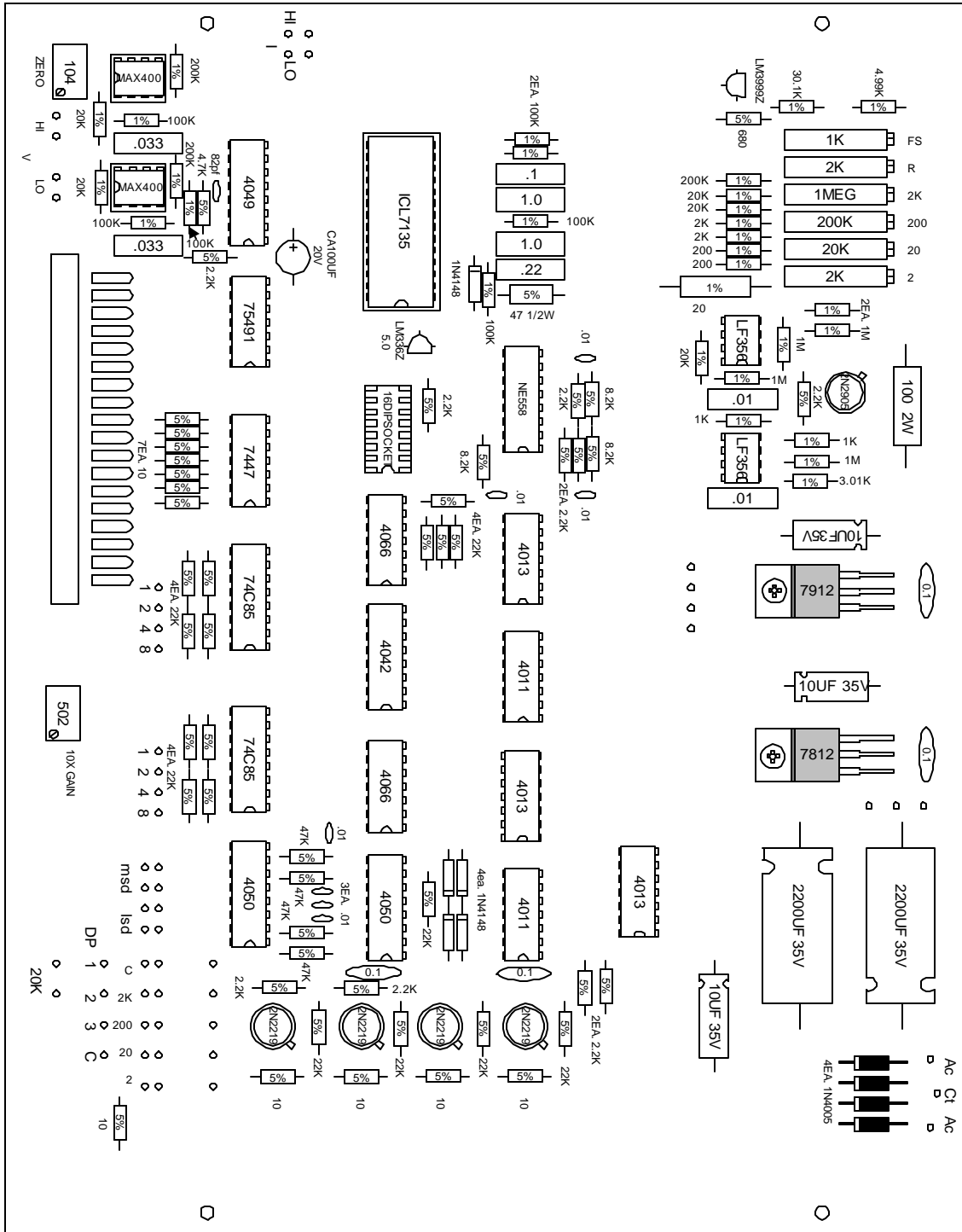

This drawing copyright 1995 by Harris Instrument Corp. This drawing contains information which is the proprietary property of Harris Instrument Corp. Copies may not be made or the contents disclosed beyond the expressed authorization of Harris Instrument Corp. and this print shall be returned upon request.

5012-05A MAIN BOARD 11-19-95
A A 9 2 0 4 1

MODEL 5012-05A RS-232 ASSEMBLY DRAWING

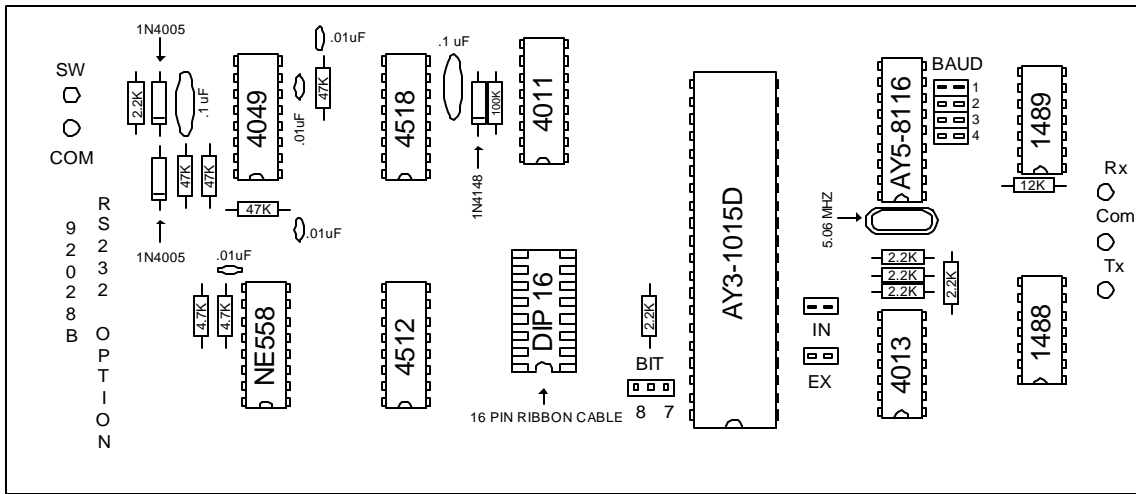

ALL RESISTORS ARE 5% 1/4 WATT

MODEL 5012-05A TEMPERATURE COMPENSATION ASSEMBLY DRAWING

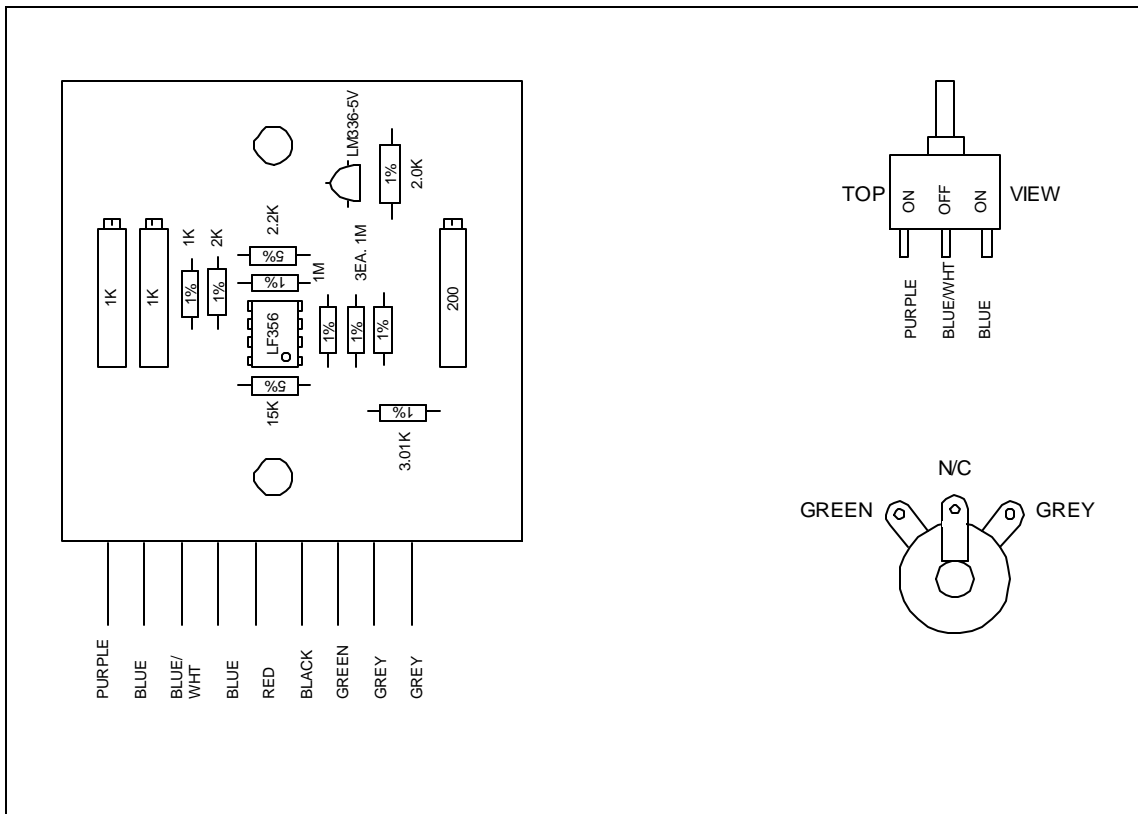

This drawing copyright 1995 by Harris Instrument Corp. This drawing contains information which is the proprietary property of Harris Instrument Corp. Copies may not be made or the contents disclosed beyond the expressed authorization of Harris Instrument Corp. and this print shall be returned upon request.

5012-05A TEMP. COMP BOARD
A81004N 9-11-95