

# Taisync

## **User Manual**

[www.taisync.com](http://www.taisync.com)

## Contents

1.	Package Contents .....	1
2.	Product Description .....	2
2.1.	Parameters .....	2
2.2.	Air Unit Interfaces .....	3
2.3.	Ground Unit Interfaces .....	4
3.	System setup .....	6
3.1.	Air Unit Installation .....	6
3.1.1.	Antenna installation .....	6
3.1.2.	Power supply .....	6
3.1.3.	Connect camera .....	7
3.1.4.	Connect flight controller (RC & telemetry) .....	7
3.2.	Ground unit installation .....	8
3.2.1.	Antenna installation .....	8
3.2.2.	Power supply .....	8
3.2.3.	Telemetry connection .....	9
3.2.4.	Connect remote controller .....	9
3.2.5.	Setup video output .....	10
3.2.6.	Use Taisync system .....	10
4.	Device Management .....	12
4.1.	Webpage Configuration .....	12
5.	Applications .....	14
5.1.	Telemetry connection .....	14
5.1.1.	Telemetry over Mission Planner (MP) .....	14
5.1.2.	Telemetry over QGroundControl (QGC): .....	16
5.2.	Get live video .....	17
5.2.1.	Getting Video through QGC .....	17
5.2.2.	Getting Video through VLC .....	18
6.	Notes .....	18
6.1.	Link performance .....	18
6.2.	RC link & remote controller .....	20
6.3.	Firmware update .....	20
6.4.	Bind operation .....	20
6.5.	Telemetry & RC .....	21
6.6.	PC Windows firewall .....	21
6.7.	Set PC IP address .....	22
7.	FAQ .....	23

# 1. Package Contents

## Air Unit & Ground Unit

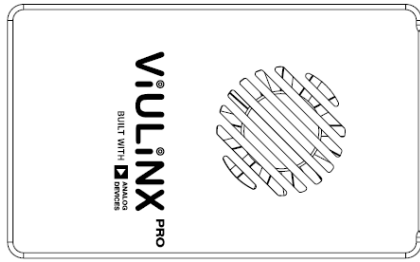

### Air unit antenna & adaptation cable × 2

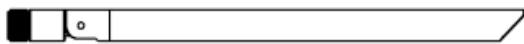

(antenna for air unit)

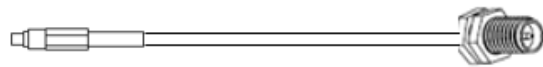

(adaptation cable for air unit)

### Ground unit antenna & adaptation cable × 2



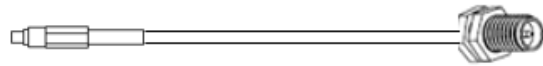

(antenna for ground unit)





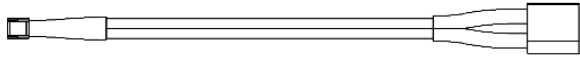

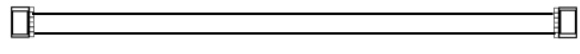
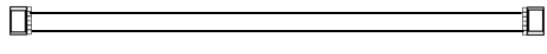
(adaptation cable for ground unit)

## Air Unit Cables

Power cable x1	
This is used to connect the output of a battery to the power input of the air unit.	
RJ45 cable x1	
This is used to connect the ETH output of a camera to the ETH input of the air unit.	
RC cable x1	
This is used to connect the PPM/S.bus port of flight controller to the RC port of the air unit.	
Serial cable x1	
This is used to connect the telemetry port of flight controller to the serial port of the air unit.	

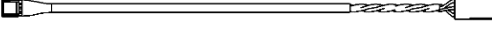
## Ground Unit Cables

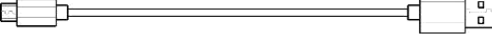
<b>Power cable x1</b>	
This is used to connect the output of a battery to the power input of the ground unit.	
<b>RJ45 cable x1</b>	
This is used to connect the ETH output of ground unit to the ETH input of a pc.	
<b>PPM RC cable x1</b>	
This is used to connect the training port of a remote controller to the RC port of the ground unit.	
<b>SBUS RC cable x1</b>	
This is used to connect the SBUS receiver to the RC port of the ground unit.	
<b>Serial cable (UART) x1</b>	
This is used to connect the telemetry port of ground station to the serial port of the ground unit.	
<b>USB cable (Micro to Type-A)×1</b>	
This is used to connect the USB port of a PC to the Micro USB port of the ground unit.	

## 2. Product Description

### 2.1. Parameters

Frequency	2.4GHz
Band width	10MHz (uplink), 10MHz(downlink)
Power	27dBm (FCC), 20dBm (CE)
Modulation	OFDM
Constellation	BPSK, QPSK, 16QAM
FEC	LDPC (1/2, 2/3, 3/4, 5/6)
Duplex	TDD
Downlink throughput	2.3Mbps ~ 8Mbps
Uplink throughput	600kbps
Encryption	AES 256
Interface	Ethernet, Serial, PPM/S.BUS
Dimension	77.8X47.3X23.5mm
Weight	97g
Rated voltage/current	DC 9~26V/1.2A (or 3S lithium battery)
Working temperature	-30°C ~65°C

## 2.2. Air Unit Interfaces

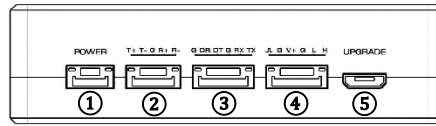

- ① Power Input Port  
Connect a 12V power source to this port. Recommended power supply is 3S battery.
- ② RJ45 Port  
Connect the Ethernet output of camera to the Ethernet input of the air unit.
- ③ Serial Port (UART)  
Connect this port to the telemetry port of a flight controller for telemetry communication with the ground unit. UART signal: LVCMOS-3.3V.
- ④ Remote Control Port (RC)  
Connect this port to the PPM/S.BUS port of a flight controller for remote control communication with the ground unit. Pin V + can provide 5V power supply.
- ⑤ Micro USB Port  
Used for debugging.

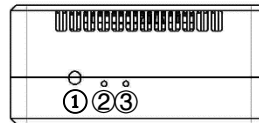

- ① Bind Button  
Press-and-hold this button to perform the binding operation.
- ② LED 1  
It's off during radio connection.
- ③ LED 2  
LED2 will be flashing in green when air unit is under binding mode. It's off during radio connection.



- ① RF2 Port  
Connect the 2nd air unit antenna to this port.
- ② RF1 Port  
Connect the 1st air unit antenna to this port.

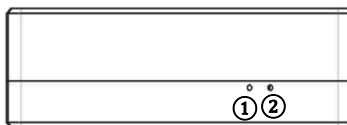

① LED3

When this LED is flashing, it means the Ethernet data link is connected; otherwise, it means the data link of the Ethernet network is disconnected.

② LED4

When this LED is on, it means the physical link of the Ethernet port is connected; when this LED is off, it means the physical link of the Ethernet port is disconnected.

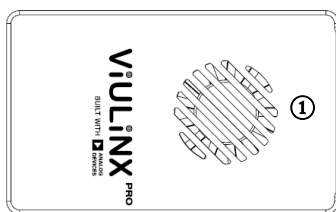

① Fan Ventilation Outlet

Don't block this fan ventilation outlet to ensure effective cooling.

## 2.3. Ground Unit Interfaces

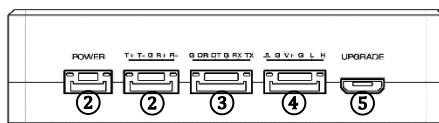

① Power Input Port

Connect a 12V power source to this port. Recommended power supply is 3S battery.

② RJ45 Port

Connect this Ethernet output port to the Ethernet input port of a PC using the supplied RJ45 cable.

③ Serial Port (UART)

Connect this port to the telemetry port of a remote controller, or the serial port of a ground control station to setup a telemetry link between the drone and the remote controller or the ground control station. UART signal: LVCMOS-3.3V.

④ Remote Control Port (RC)

Connect this port to the PPM/S.BUS port of a remote controller. Pin V + can provide 5V power supply.

⑤ Micro USB Port

Used for debugging.

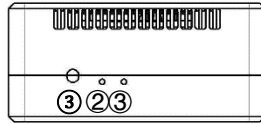

① Bind Button

Press-and-hold this button to perform the binding operation.

② LED 1

When this LED is on, it means the air-to-ground link is connected; when this LED is off, it means the air-to-ground link is disconnected.

③ LED 2

When this LED is on, it means the ground -to-air link is connected; when this LED is off, it means the ground -to-air link is disconnected.

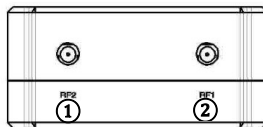

① RF2 Port

Connect the 2nd air unit antenna to this port.

② RF1 Port

Connect the 1st air unit antenna to this port.

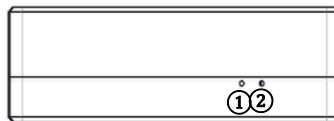

① LED3

When this LED is flashing, it means the Ethernet data link is connected; when this LED is off, it means the data link of the Ethernet network is disconnected.

② LED4

When this LED is on, it means the physical link of the Ethernet port is connected; when this LED is off, it means the physical link of the Ethernet port is disconnected.

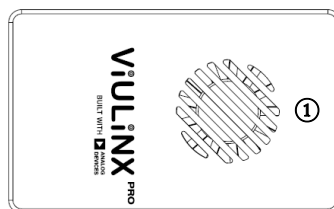

① Fan Ventilation Outlet

Don't block this fan ventilation outlet to ensure effective cooling.

### 3. System setup

#### 3.1. Air Unit Installation

##### 3.1.1. Antenna installation

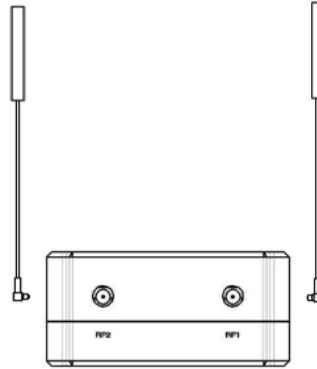

Insert the air unit antennas into the RF ports. Antenna connector clicks in when properly installed.

**Note:**

1. To avoid equipment damage, install antennas before powering on the units.
2. When mount air unit to drone, make sure the antennas are not both blocked by any part of the drone.
3. Both antennas need to be installed.
4. Ensure the antenna connector is vertical to the module when it is pushed into the RF port.
5. Do not pull the cable to uninstall the antenna. Hold the connector and pull it vertically out of the RF port to uninstall antennas properly.

##### 3.1.2. Power supply

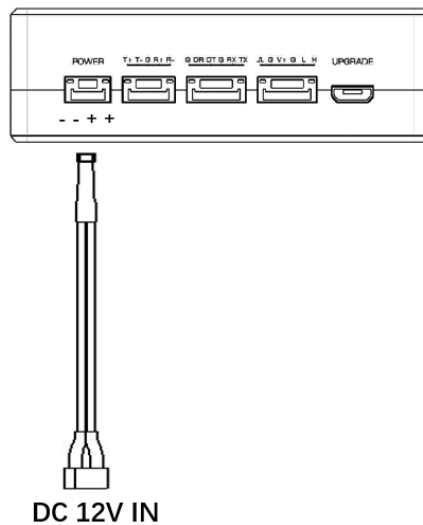

Pin-out: - - + +. Insert the four-pin connector of supplied power cable to the power port of the air unit and connect the orange power connector of supplied power cable to a battery output, or the power supply port of a drone. Recommended voltage is 12V.

**Note:**

1. To avoid equipment damage, install antennas before powering on the units.
2. Recommended rated voltage/current is DC12V/1.2A (or 3S lithium battery).

**3.1.3. Connect camera**

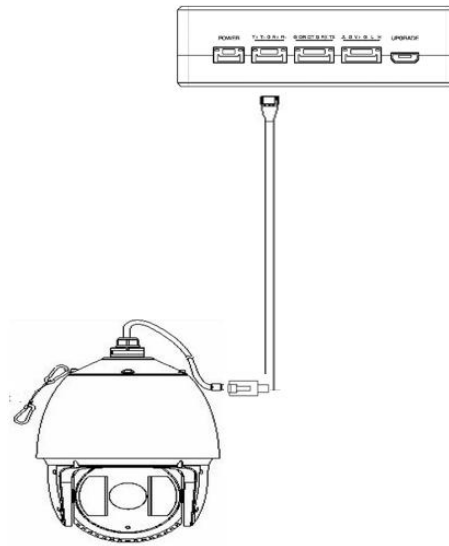

Connect the Ethernet video output port of a camera to the Ethernet video input port of the air unit.

**3.1.4. Connect flight controller (RC & telemetry)**

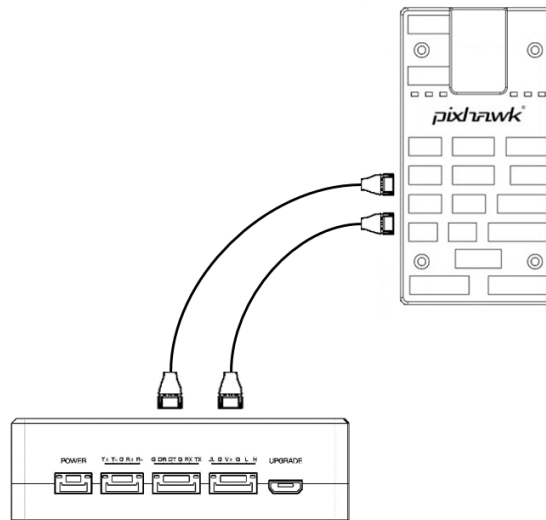

Insert the six-pin connector of supplied serial cable to the serial port of the air unit and connect the other end of the serial cable to the telemetry port of a flight controller.

Insert the supplied RC cable to the RC port of the air unit and connect the other end of the RC cable to the PPM/S.BUS port of a flight controller.

## 3.2. Ground unit installation

### 3.2.1. Antenna installation

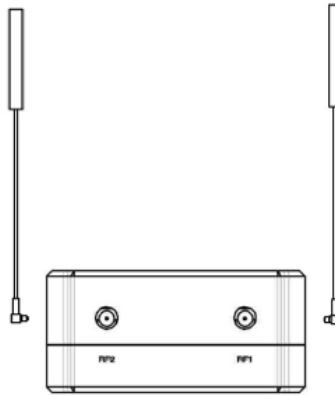

Insert the ground unit antennas into the RF ports. Antenna connector clicks in when properly installed.

**Note:**

1. To avoid equipment damage, install antennas before powering on the units.
2. Both antennas need to be installed.
3. Ensure the antenna connector is vertical to the module when it is pushed into the RF port.
4. Do not pull the cable to uninstall the antenna. Hold the connector and pull it vertically out of the RF port to uninstall antennas properly.

### 3.2.2. Power supply

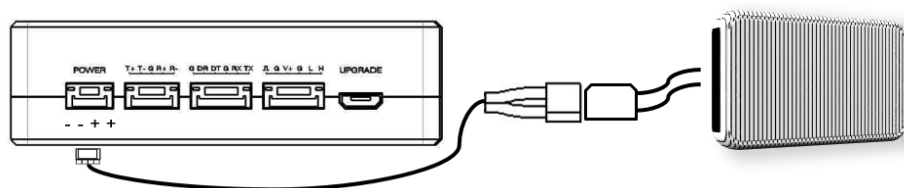

Insert the power connector of a power source into the power port of the ground unit.

**Note:**

1. Recommended rated voltage/current is DC12V/1.2A (or 3S lithium battery).
2. To avoid equipment damage, install antennas before powering on the units.

### 3.2.3. Telemetry connection

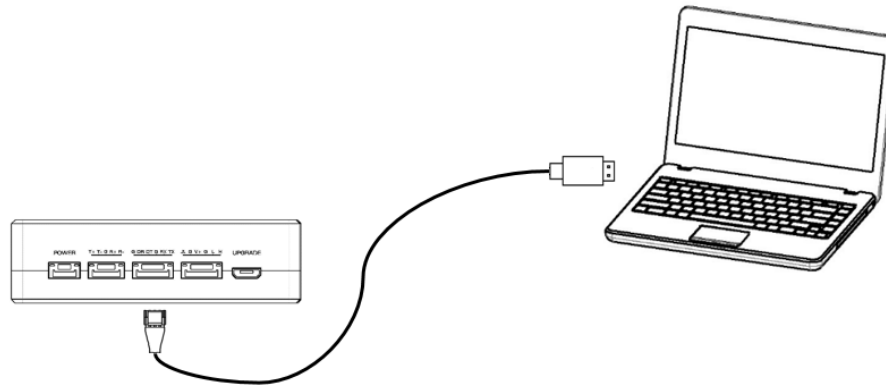

Insert the six-pin connector of supplied serial cable to the serial port of the ground unit and connect the other end of supplied serial cable to the telemetry port of the ground control station.

**Note:**

1. Ensure the baud rate of ground station's serial port and the baud rate of Taisync module's serial port are configured to be the same.
2. Ensure the pin-out of serial cable matches the pin-out of Taisync module's serial port.

### 3.2.4. Connect remote controller

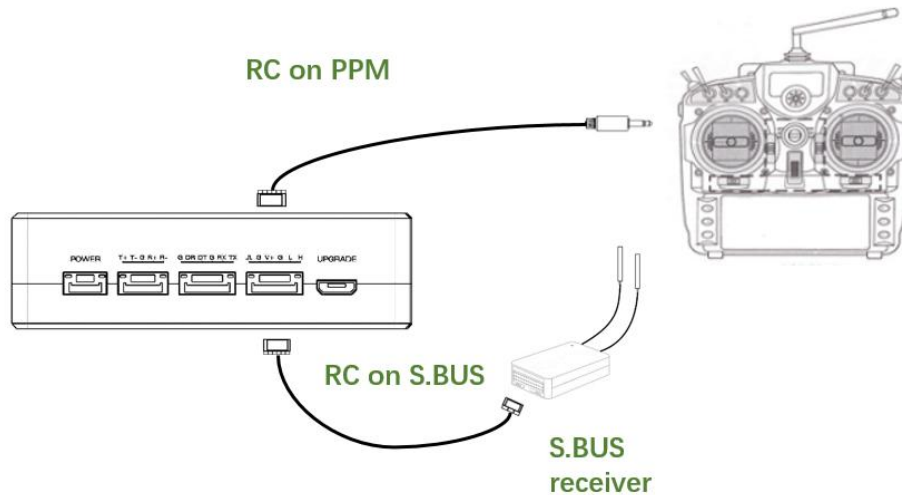

Using PPM mode: Insert the trainer port connector of the supplied RC cable to the trainer port of a remote controller and connect the six-pin connector of the RC cable to the RC port of the ground unit.

Using S.BUS mode: Insert the six-pin connector of the RC cable to the RC port of the ground unit, connect the other end of the RC cable to a S.BUS receiver, and the S.BUS receiver communicates with the remote controller wirelessly.

**Note:**

1. Ensure the RC cable's pin-out matches the pin-out of Taisync module RF port.
2. If a S.BUS receiver is used, there should be enough guard band between the working frequency band of the receiver and the working frequency band of Taisync module, for instance, 2.4GHz receiver and 2.4GHz Taisync module could not be used at the same time.

### 3.2.5. Setup video output



Ground unit can output video over Ethernet cable to a PC

**Note:**

To get the video on PC, connect the Ethernet port of the ground unit to the Ethernet port of a PC, the IP address of the PC is configured in the same subnet with camera.

### 3.2.6. Use Taisync system

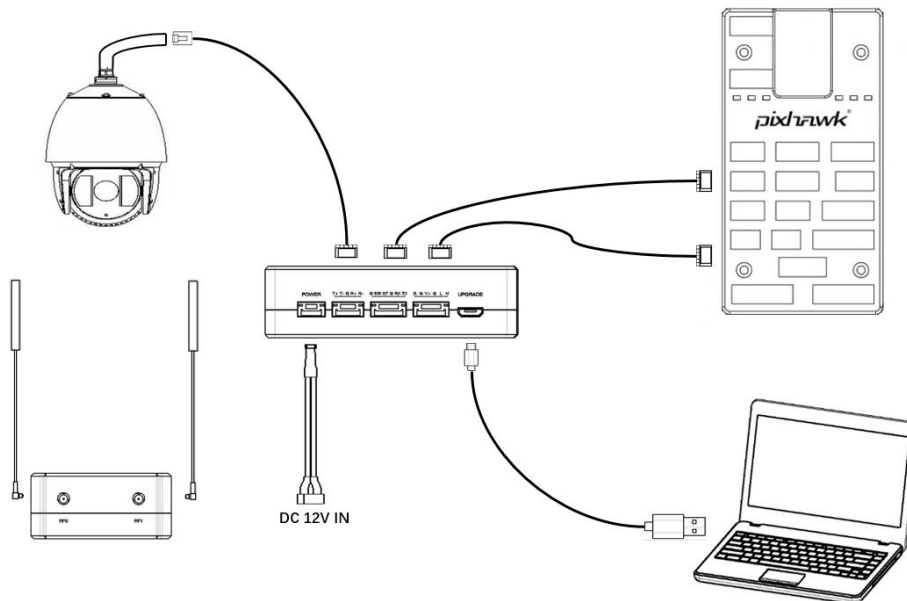

1. Install antennas to the air unit.
2. Connect camera's Ethernet video output to Ethernet port of the air unit.

3. Connect the PPM/S.BUS port of the flight controller to the RC port of the air unit.
4. Connect the telemetry port of the flight controller to the serial port of the air unit.
5. Turn on the camera and set the PC IP address in the same subnet of camera.
6. Connect a 12V DC power source to the power port of the air unit and turn it on.
7. If the latest firmware is needed, can upgrade through Web UI. For further details go through the next topic Device management.

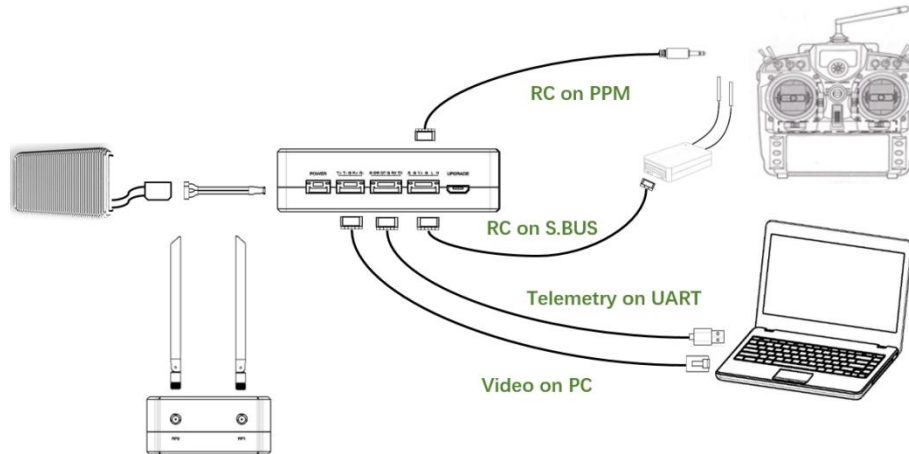

1. Install antennas to the ground unit.
2. Configure the remote controller to be in trainer mode. If PPM mode is used, connect the RC port of the ground unit to the trainer port of the remote controller. If S.BUS mode is used, a S.BUS receiver needs to be connected to the ground unit using supplied cable, and the wireless connection between the S.BUS receiver and the remote controller need to be established.
3. Connect the USB port of a ground control station to the serial port of the ground unit through a TTL-2-USB adaptor if you want to use telemetry link.
4. Connect a PC to the Ethernet port of the ground unit.
5. Connect a 12V DC power to the power port of the ground unit and turn on the power.
6. If the latest firmware is needed, can upgrade through Web UI. For further details go through the next topic Device management.
7. After downlink and uplink are established, both LEDs of the ground unit will be on.

## 4. Device Management

### 4.1. Webpage Configuration

Equipment management can be done via webpage. Management IP address of Ground unit is 192.168.199.16 by default, and 192.168.199.18 for Air unit.

At page of **Status**→**Baseband Status**, there're detailed real-time information displayed, like LDPC, RSSI, SNR, link status, etc.

Product: Wireless		Software Version: 1.2	
Wireless			
Status	Config	Upgrade	
<b>BaseBand Status</b>			
<b>Device Information</b>		<b>BaseBand Status</b>	
A-LdpcPass	36571	G-LdpcPass	335189
A-LdpcFail	21	G-LdpcFail	77
A-Snr	11	G-Snr	19
A-RSSI1	-54	G-RSSI1	-80
A-RSSI2	-56	G-RSSI2	-52
A-RxVga1	36	G-RxVga1	61
A-RxVga2	38	G-RxVga2	33
A-TxPower	30	G-TxPower	30
A-LinkStatus	track	G-LinkStatus	track
A-LinkQuality	100%	G-LinkQuality	100%
A-AD9361Temp	45	G-AD9361Temp	50
A-FPGATemp	47	G-FPGATemp	44
A-CurrentAntenna	auto-rf1	G-CurrentAntenna	auto-rf2
Bind Status	bind	Uart1 RecvByte	0
MCS	16QAM_1_2(7.86Mbps)	Uart1 SendByte	0
Distance	48	SBUS Recv Count	0
Downlink DataRate	0kbs	PPM Recv Count	0
Uplink DataRate	0kbs		
Current Tx Freq	1461		
Current Rx Freq	1461		

At page of **Status**→**Device Information**, there're SN, software version, Antenna mode, Radio, Bandwidth and Maximum communication range.

Product: Wireless		Software Version: 1.2	
Wireless			
Status	Config	Upgrade	
<b>BaseBand Status</b>			
<b>Device Information</b>		<b>Device Information</b>	
SN			
Firmware Version	3.4.1.2_20231007		
Baseband Version	C20211018		
Antenna Mode	DUAL_ANT_1T2R		
Radio	1.4G_1W		
Max Range	55KM		
Bandwidth	10M-10M		

At page of **Config**→**Network Settings**, user can configure equipment IP address of Ground unit and telemetry destination IP address/UDP port.

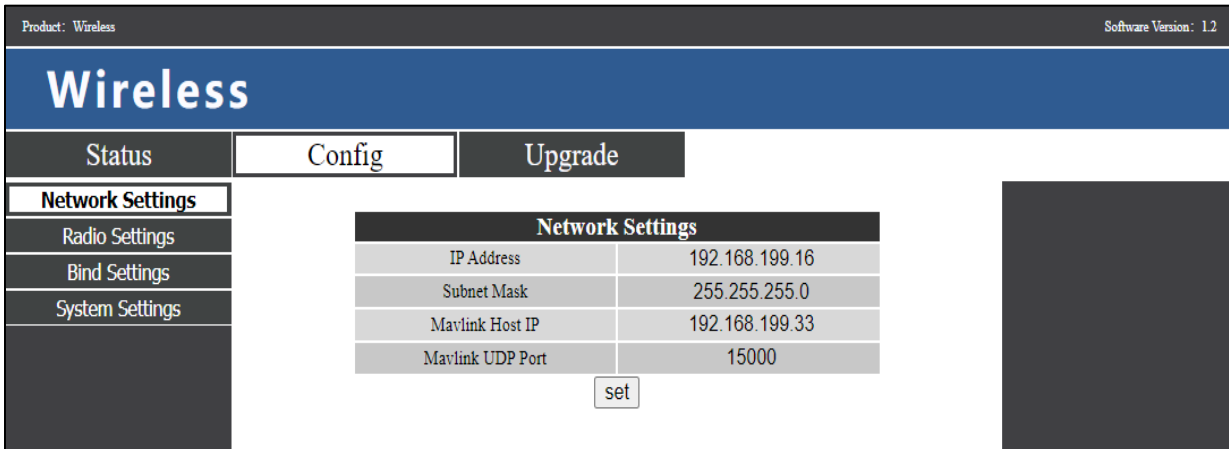

At page of **Config**→**Radio Settings**, frequency hopping can be enabled/disabled by selecting auto/manual; frequency can be manually input when hop is manual; options of auto/antenna1/antenna2 are available for antenna select of both Air and Ground Unit.

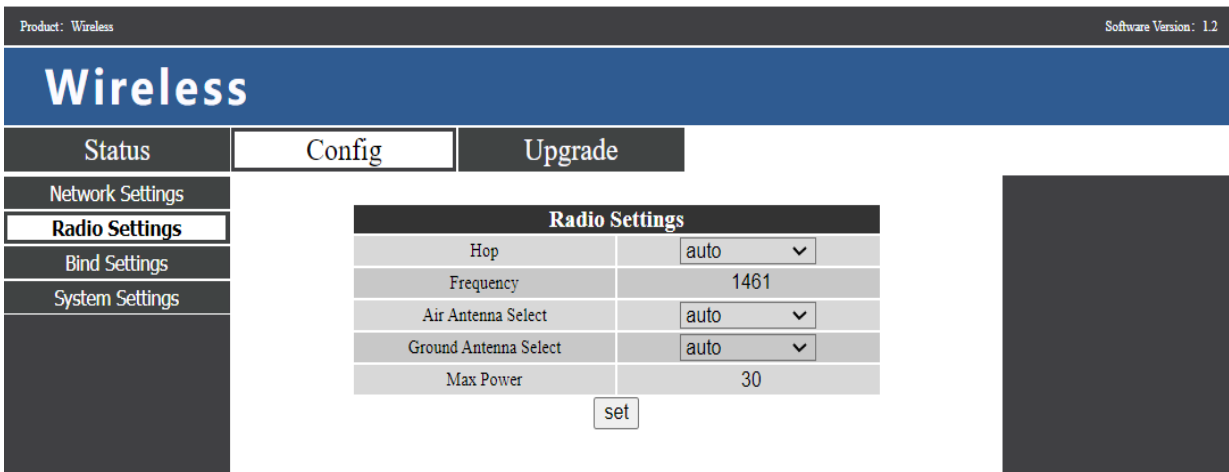

At page of **Config**→**Bind Settings**, bind can be done by clicking bind button.

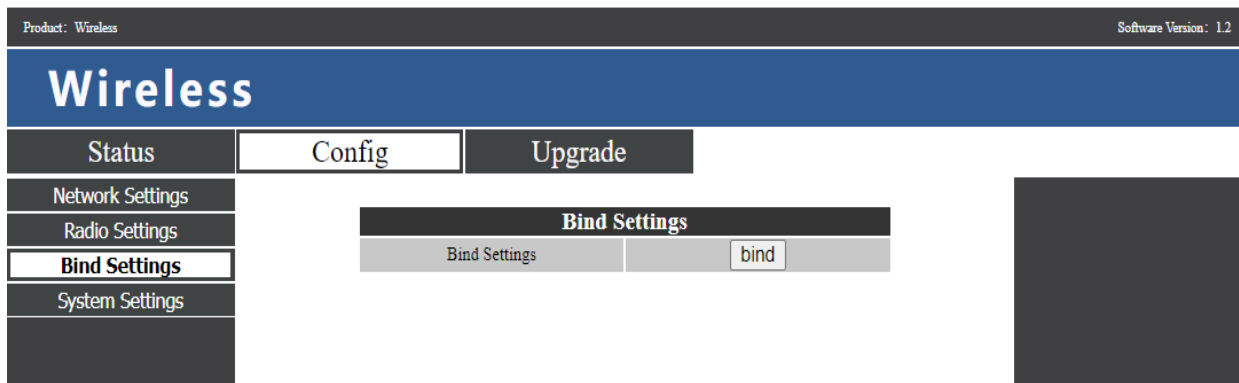

At page of **Config**→**System Settings**, options of 9600/57600/115200 are available for serial port baud rate; Options ppm / sbus are available for RC Type; Options of BPSK/QPSK/16QAM/Adaptive are available for modulation mode; Also options Pilot / Observer for Ground Role in the network are there; restore to factory setting by option of enable.

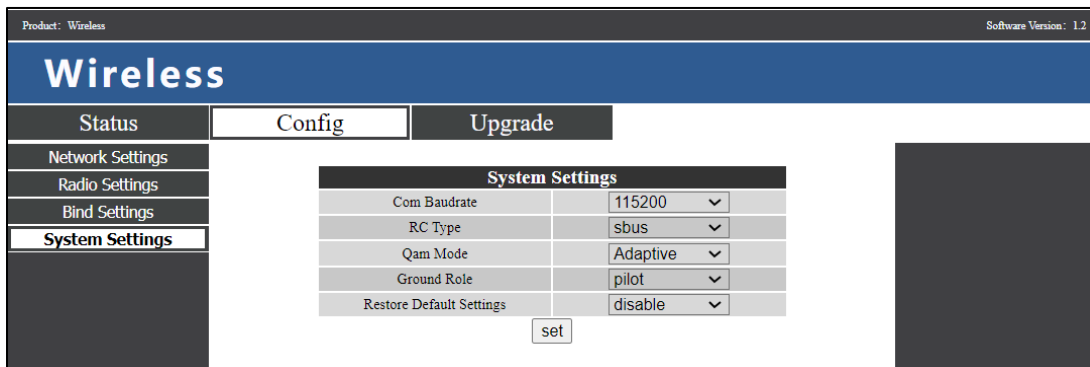

At page of **Upgrade**→**Upgrade**, firmware replacement can be done.

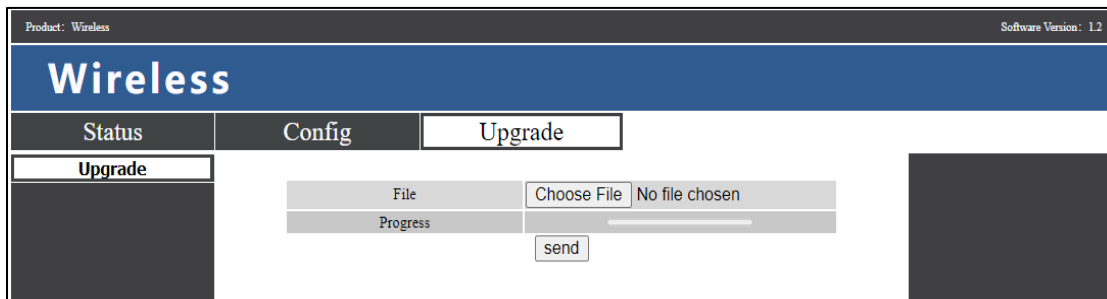

## 5. Applications

### 5.1. Telemetry connection

At the Air side telemetry Port of air unit connects “TELEM1” Port of a flight control (Pixhawk4). Getting telemetry data through QGC and MP are described below.

#### 5.1.1. Telemetry over Mission Planner (MP)

- I. **Telemetry data through Serial (TTL to USB):** Connect the TTL to USB connector of the ground unit to the USB port of the PC. As always, it's compulsory to have the same communication baud rate.

Open MP, select the serial port, enter the baud rate, and click on connect as circled in the screenshot below

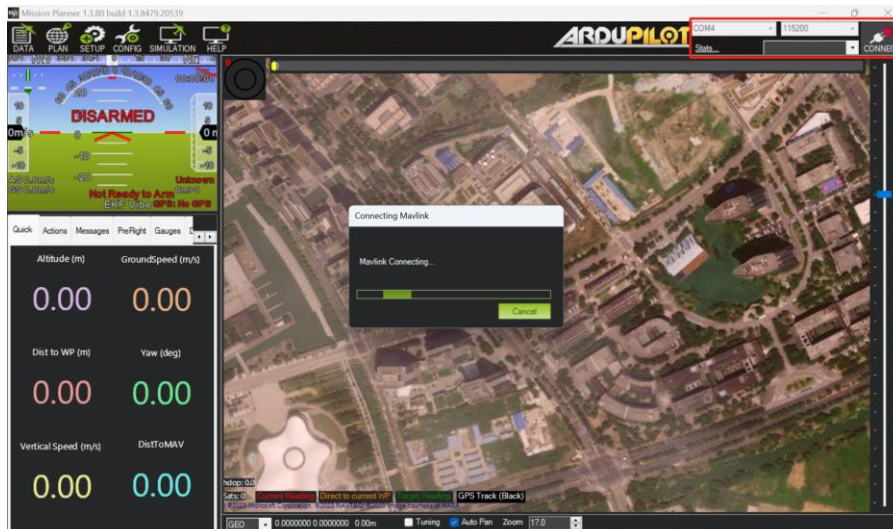

- II. **Telemetry data through UDP:** Connect the ethernet connector of the ground unit to the ethernet port of the PC. Select the UDP and enter the baud rate and click on connect. The destination address (MavLink Host IP) should be the IP address of the PC and enter the UDP port the same as MavLink UDP port. i.e. 15000.

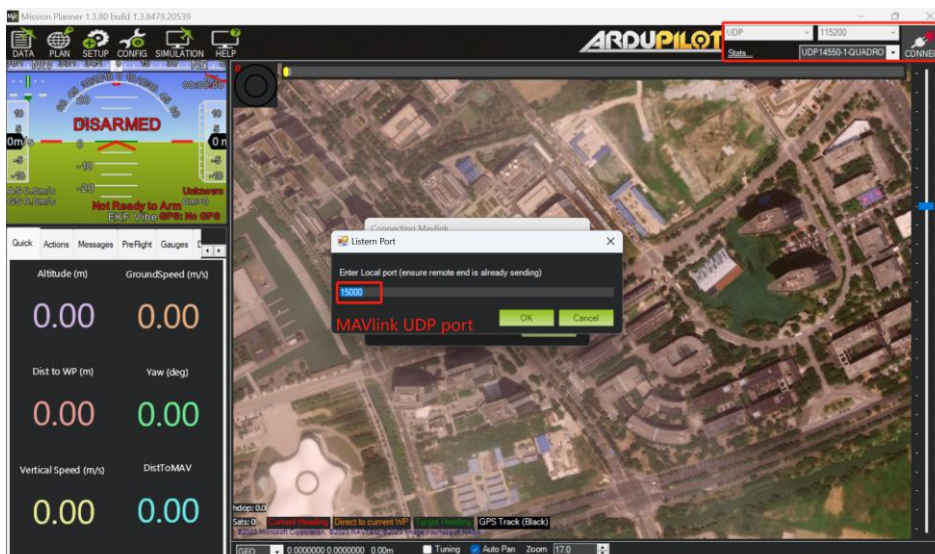
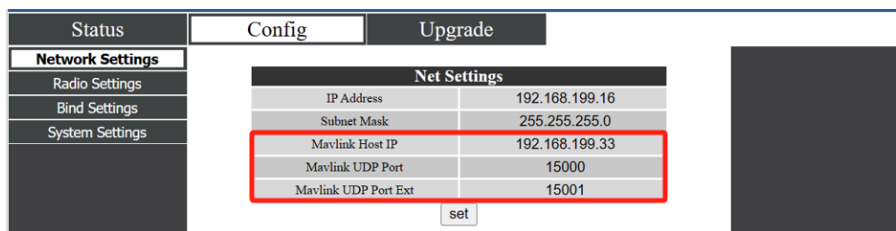

## 5.1.2. Telemetry over QGroundControl (QGC):

- I. **Telemetry data through Serial (TTL to USB):** For telemetry data go to the QGC **application settings** → **Comm Link** → **Add** and enter the name select the Type Serial select the serial port of the PC connected to the telemetry port of the ground unit and the Baud Rate same as web UI system settings and click ok.

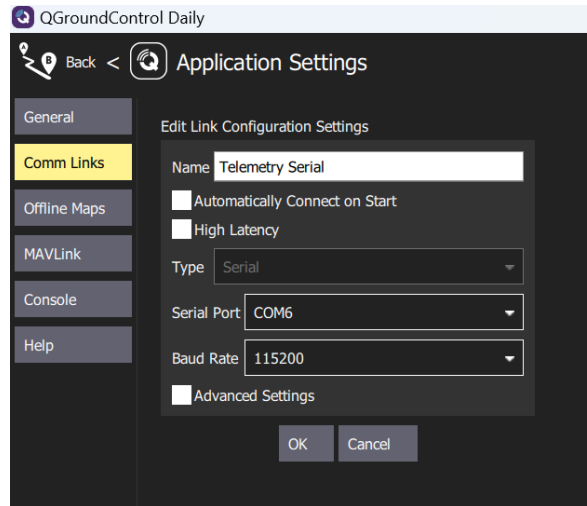

Status	Config	Upgrade
Network Settings		
Radio Settings		
Bind Settings		
<b>System Settings</b>		

System Settings	
Com Baudrate	115200
RC Type	sbus
Qam Mode	Adaptive
Ground Role	pilot
Restore Default Settings	disable

set

- II. **Telemetry data through UDP:** For telemetry data go to the QGC **application settings** → **Comm Link** → **Add** and enter the name select the Type UDP enter the MavLink UDP port the same as web UI Network settings and click ok.

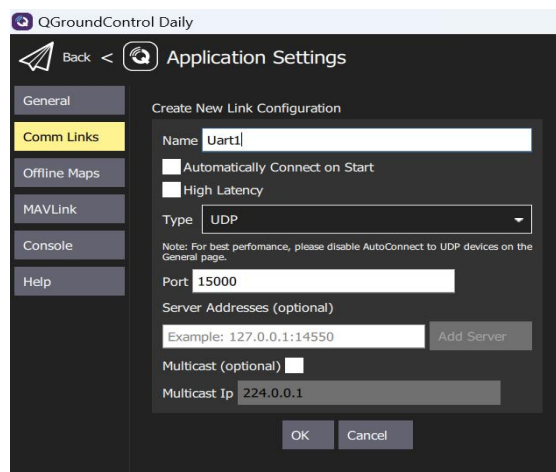

Status	Config	Upgrade
<b>Network Settings</b>	<b>Net Settings</b>	
Radio Settings	IP Address	192.168.199.16
Bind Settings	Subnet Mask	255.255.255.0
System Settings	Mavlink Host IP	192.168.199.33
	Mavlink UDP Port	15000
	Mavlink UDP Port Ext	15001

## 5.2. Get live video

Get real-time video through RTSP on media players like QGC/VLC. Make sure IP addresses of PC and camera are in the same subnet. Connect the IP camera to the Air unit through the ETH cable.

### 5.2.1. Getting Video through QGC

For real time video go to the QGC application settings → General → Video settings. Select RTSP video stream from the source dropdown and RTSP URL i.e., `rtsp://admin:12345678@192.168.0.2:554` here admin means the username, 12345678 means the password, and 192.168.0.2 is the IP address of the camera.

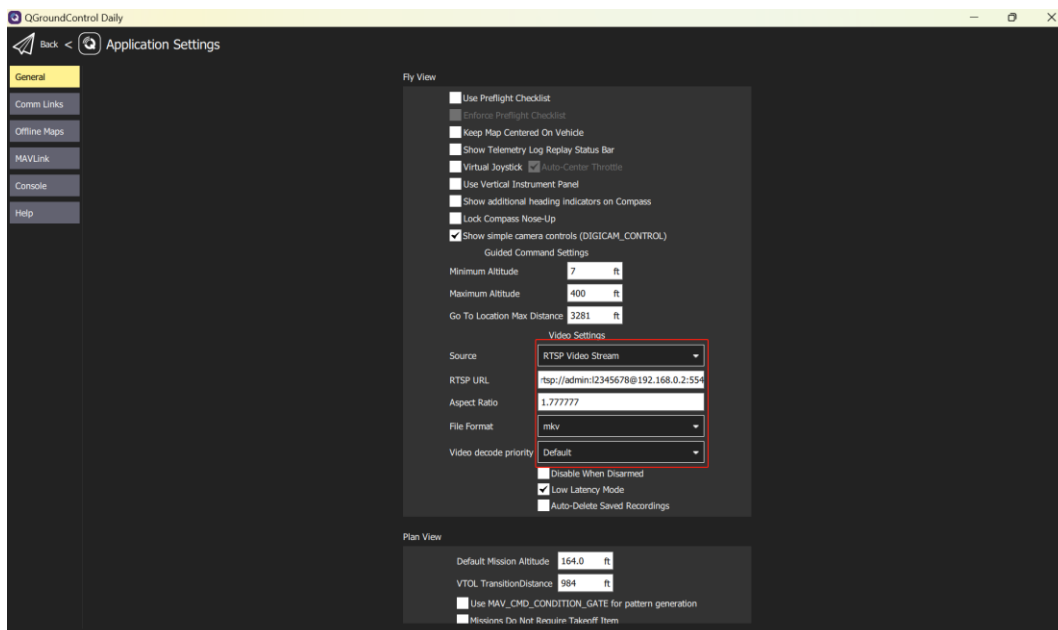

## 5.2.2. Getting Video through VLC

Open VLC go to media on left top corner and select open network stream from the dropdown menu a popup window will open go to network and enter the RTSP URL i.e., <rtsp://admin:12345678@192.168.0.2:554> here admin means the username, 12345678 means the password, and 192.168.0.2 is the IP address of the camera.

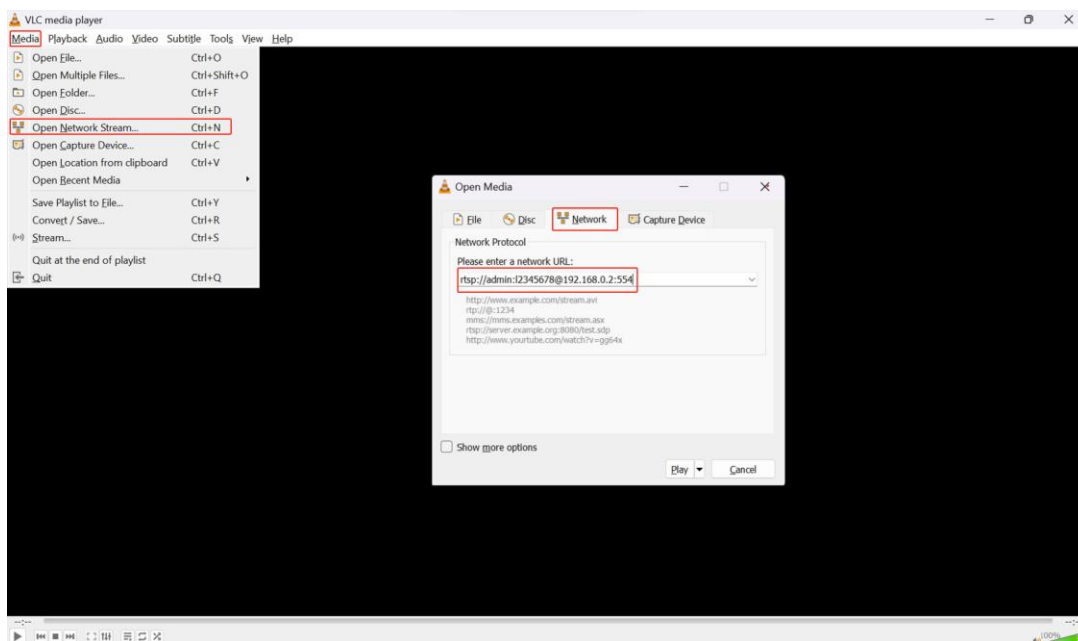

## 6. Notes

### 6.1. Link performance

- Interference from 2.4GHz WiFi

WiFi operates at 2.4GHz band with bandwidths of 20MHz and 40MHz. WiFi can generate both co-channel interference and adjacent channel interference to the 2.4GHz wireless link of a drone. Even if there is not a WiFi router is available for a WiFi device (for example, WiFi of a phone) to connect with, a WiFi device periodically transmits beacon/probe signals. So, when you operate a drone in the field with 2.4GHz wireless link, it is important to turn off WiFi modem/hotspot of a phone, or a laptop. If WiFi relay of the video from the ground station is desired, it is recommended to use a 5.8GHz WiFi modem.

- Interference from Bluetooth device

Bluetooth operates on 2.4GHz in frequency hopping mode. So a Bluetooth mouse, Bluetooth joystick, car key or any Bluetooth device that is actively working and next to ground station will interfere the reception of downlink video. Please avoid using Bluetooth device when operate a drone with 2.4GHz wireless link.

- **Interference from wireless device in co-existence**

Another wireless device that operates on bands close to 2.4GHz and the device is placed close to the drone's 2.4GHz wireless module can interfere the drone's wireless link. For example, some drones have both LTE link and point-to-point wireless link. Particularly, the LTE operating on 2.3GHz band can be a problem. If the antenna of the LTE module is placed close to the antenna of the 2.4GHz point-to-point wireless module, the receiver of 2.4GHz module can be saturated by the LTE signal when it is transmitting. Thus, the range/performance of the 2.4GHz module will be significantly degraded.

- **Interference from HDMI**

When HDMI source/cable is close the antenna of 2.4GHz wireless modem, the HDMI source/video will interfere the 2.4GHz wireless signal (including WiFi).

<https://h30434.www3.hp.com/t5/Notebooks-Archive-Read-Only/HDMI-interfering-with-WiFi-connectivity/td-p/4535026>

<http://www.dslreports.com/forum/r27141612-HDMI-connect-interferes-with-wifi>

It is recommended that install the antenna at least 25cm away from the HDMI source/cable. A good shield HDMI cable can be a resolution too. The following shield HDMI cable uses 360-degree shield termination, which is recommended practice.

<https://interferencetechnology.com/hdmi-cables-emi/>

<http://www.l-com.com/content/Article.aspx?Type=P&ID=10699>

<http://www.l-com.com/audio-video-micro-hdmi-to-hdmi-cables>

<http://www.l-com.com/audio-video-hdmi-female-to-micro-hdmi-male-adapter>

- **Interference from USB3.0 divider/hub**

USB3.0 dividers or hubs may cause EMI to wireless device. When using USB3.0 dividers or hubs, please check if EMI is existing.

- **RF cable connector/Antenna connector check**

Before flight, check if the antennas are connected to the modules. Running module without antenna connected results in very short range and potentially can damage the module. It is recommended to check the connection of all RF connectors. Loose connection can degrade the range significantly.

- **Antenna placement**

Place the two air antennas so that no matter what position the drone is, at least one antenna is not blocked by the payload from the ground station.

If the drone will fly in full throttle, it will lean forward. Install the air antenna so that it is close to be vertical to the ground when the drone moves forward in full throttle.

- **Battery level**

The performance will degrade if the battery runs low, even though it might still power the units up.

## **6.2. RC link & remote controller**

The RC link of Taisync module supports the PPM and S.BUS protocols. If the PPM protocol is used, you need to configure the remote controller to PPM mode and turn off the wireless transmission of the remote controller. If the S.BUS protocol is used, the wireless working frequency of the receiver connected to the remote controller must work in different frequency bands with the working frequency of Taisync module and have a certain isolation guarantee.

If you do not use the RC link of Taisync module, you should pay attention to the remote link working frequency of the remote controller when using the RC link of the remote controller. If it is in the same frequency band as the working frequency of Taisync module, it will cause interference with each other.

Avoid interference with Taisync module by the wireless link of the remote controller or receiver when using Taisync system.

## **6.3. Firmware update**

Upgrade files: FPGA upgrade file for air unit, FPGA upgrade file for ground unit, MCU1 upgrade file for air unit, MCU1 upgrade file for ground unit, MCU2 upgrade file for air unit, MCU2 upgrade file for ground unit.

Upgrade files are upgraded using webUI. During the upgrade, the power can not be powered off and the normal connection of ETH cable should be ensured at the same time. If the upgrade fails, the power can not be powered off, please try to upgrade again directly. Otherwise, it will be necessary to return to us to use special burning tools for firmware burning.

## **6.4. Bind operation**

“Bind” is used to pair an air unit with ground unit.

To pair an air unit and a ground unit:

1. Both air unit and ground unit are powered on.
2. Connect the air and ground unit.

3. Press the physical bind button of the air unit, last 5s+. The LED light next to the bind button flashes green, indicating that it is in the binding state.
4. Press the physical bind button of the ground unit, last 5s+. The LED light next to the bind button flashes green, indicating that it is in the binding state.
5. When the link indicator LEDs of ground unit are always on, it indicates that the air and ground unit is binded.

**Note:**

1. If modules binding with different firmware version, the binding operation may fail.
2. If the program of the air unit or the ground unit is burned incorrectly, such as burning the air unit to the ground unit, and performing the binding operation between the wrong air unit and the ground unit, the binding operation will fail.
3. Units are bound already before factory delivery, customer do not need to bind again after unboxing.
4. If unit is restored to factory setting, bind again is needed.

## 6.5. Telemetry & RC

### ●Telemetry

UART signal: LVCMOS-3.3V.

Pin-out: G DR DT G RX TX.

Debug-DR/DT, Telemetry-RX/TX.

### ●RC

PPM/S.BUS signal: LVCMOS-3.3V.

Pin-out: II G V+ G L H.

II: PPM/SBUS G: GND V+: Power (5V) G: GND L: CAN-bus-L

H: CAN-bus-H (CAN-bus is not supported yet).

The RC port can provide 5V power supply for S. BUS mode.

## 6.6. PC Windows firewall

Make sure PC firewall is disabled in case video and/or telemetry is blocked. Here take Windows10 operation system for reference. Path: Control Panel\System and Security\Windows Firewall\Customize Settings. Set Private/Public network settings as 'Turn off Windows Firewall' as below, click 'OK'.

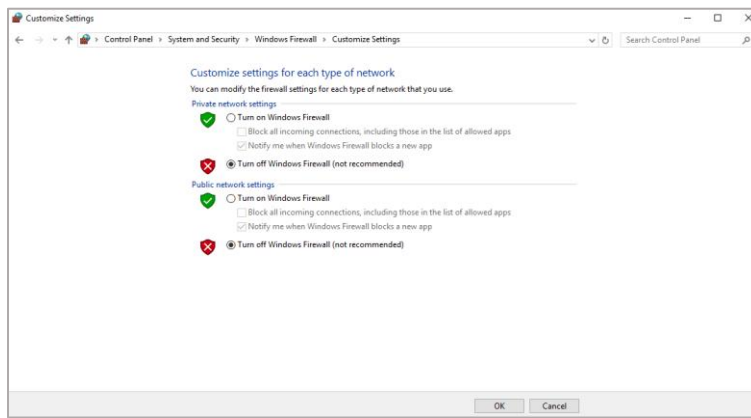

## 6.7. Set PC IP address

PC IP address should be set in the same subnet with camera, IP address can be set following below steps:  
Double click 'Ethernet' at Control Panel\Network and Internet\Network Connections.

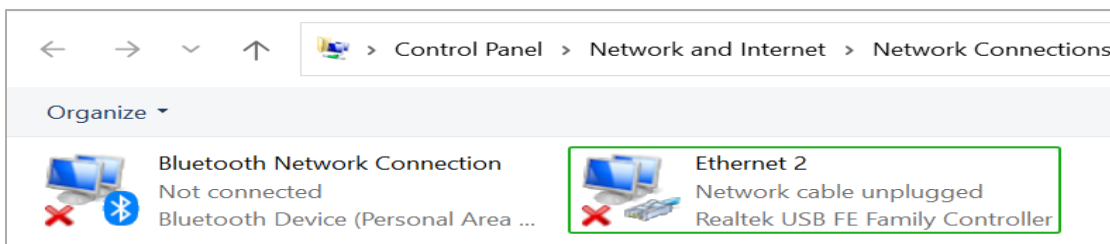

Double click 'Internet protocol version 4(TCP/IPv4)', set PC IP address like below, click 'OK' to finish.

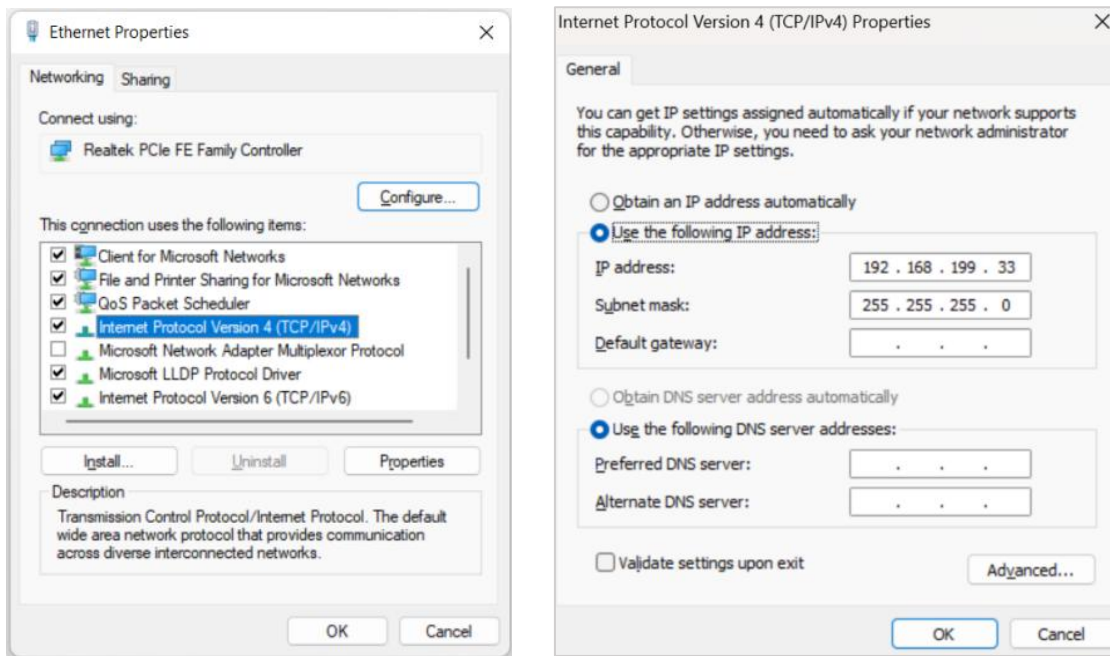

## 7. FAQ

<b>Q1: How does the Taisync module supply power?</b>
Old hardware version Ethernet port unit: DC, power supply range: 9-15V, recommended to use 12V, Taisync provides power supply cables.
New hardware version Ethernet port unit: DC, power supply range: 9-26V, recommended to use 12V, Taisync provides power supply cables.
HDMI port Ground unit: DC, power supply range: 9-15V, recommended to use 12V, Taisync provides power supply cables.
HDMI+AV/SDI+AV Air unit: DC, power supply range: 9-26V, recommended to use 12V, Taisync provides power supply cables.
<b>Q2: Can the Taisync module be powered on before antennas installation?</b>
The antennas must be installed before power on.
<b>Q3: How many antennas do Taisync's air unit need to be installed?</b>
Two antennas need to be installed.
<b>Q4: How many antennas do Taisync's ground unit need to be installed?</b>
Two antennas need to be installed.
<b>Q5: Can different types of remote controllers be used to control drone?</b>
Yes, just output standard PPM signals through the coach port, or use S. BUS receiver.
<b>Q6: Can two air units be installed on a drone?</b>
No, a drone can only integrate one air unit.
<b>Q7: Can two ground units be installed at the receiving end?</b>
The ptp system can only install one ground unit; the ptmp system supports more than one ground units.
<b>Q8: There are some devices nearby, such as WIFI, Bluetooth and so on. Can they be opened when flying?</b>
If 2.4GHz Taisync modules used, make sure to turn off WIFI, Bluetooth and other functions of other devices like mobile phone, car key, because these devices are working in 2.4 GHz band, it can cause interference.
<b>Q9: There are USB3.0 hub and/or HDMI cable used, will they affect the Taisync wireless system?</b>
If 2.4GHz Taisync modules used, make sure to keep USB3.0 hub and/or HDMI cable away from antenna.
<b>Q10: After integrating the Taisync air unit, GPS is not good at searching for stars. What should we do?</b>
Please check whether the antennas of air unit is far away from GPS to avoid blocking interference to GPS. The frequency band of 1.4G module is close to working frequency of GPS, so it is necessary to ensure a certain degree of antenna isolation.

<b>Q11: What do the four LED lights of the ground unit stand for?</b>
LED 1 (downlink Indicator): The LED is on indicates that the air-to-ground link is connected; the LED is not on indicates that the air-to-ground link is disconnected. LED1 locates at the same side of bind button and next to bind button.
LED 2(uplink Indicator): The LED is on indicates that the ground-to-air link is connected; LED is not on indicates that the ground-to-air link is disconnected. LED2 locates at the same side of bind button and next to LED1.
LED 3 (Network Data Link Indicator): The LED is flickering indicates that the data link is connected; not flickering indicates that the data link is disconnected. Seen from fan up-ward view, LED3 locates at the left side of LED4.
LED 4 (Network Physical Link Indicator): The LED is on indicates that the data link is connected; otherwise it indicates that the data link is disconnected. Seen from fan up-ward view, LED4 locates at the right side of LED3.
<b>Q12: What do the two LED lights of the HDMI ground unit stand for?</b>
LED 1 (downlink Indicator): The LED is on indicates that the air-to-ground link is connected; the LED is not on indicates that the air-to-ground link is disconnected.
LED 2(uplink Indicator): The LED is on indicates that the ground-to-air link is connected; the LED is not on indicates that the ground-to-air link is disconnected.
<b>Q13: What if the uplink LED indicator of ground unit is not on?</b>
Please follow the following steps:
1) Please check the power supply of the air and ground unit is normal.
2) Please check if air unit and ground unit is bound successfully.
3) Please check the antennas installation of the air and ground units is normal: whether the antennas is blocked; whether the antennas connection is loose; whether the rf cable and port is not tightened;
4) Check whether the TX frequency of the ground unit is consistent with the RX frequency of the air unit with Taiysnc PC management software.
5) If the above steps can not solve the problem, please contact Taisync technical support staff.
<b>Q14: What if the downlink LED indicator of ground unit is not on?</b>
Please follow the following steps:
1) Please check the power supply of the air and ground unit is normal.
2) Please check if air unit and ground unit is bound successfully.
3) Please check the antennas installation of the air and ground units is normal: whether the antennas is blocked; whether the antennas connection is loose; whether the rf cable and port is not tightened;
4) Check whether the TX frequency of the ground unit is consistent with the RX frequency of the air unit with Taiysnc PC management software.
5) If the above steps can not solve the problem, please contact Taisync technical support staff.
<b>Q15: What if the Ethernet physical link LED indicator of ETH ground unit is not on?</b>
Please follow the following steps:
1) Please check whether the power supply of the air and ground unit is normal.
2) Please check whether the RJ45 cable is normal.
3) Please check power supply of camera.

4) If the above steps can not solve the problem, please contact Taisync technical support staff.
<b>Q16: What if the Ethernet datel link LED indicator of ETH ground unit is not flashing?</b>
Please follow the following steps:
1) Please check whether the Ethernet physical link LED indicator is on.
2) Please check whether there's stream coming out from camera.
3) If the above steps can not solve the problem, please contact Taisync technical support staff.
<b>Q17: After connecting Taisync module, telemetry can not be connected properly?</b>
Please follow the following steps:
1) Please check whether the link state is normal, please refer to Question 13 and Question 14 if it is abnormal.
2) Please check whether the RC port both the air and the ground units is correct.
3) Please check whether the RC connecting between flight controller and air unit is correct and that between ground unit and remote controller is correct.
4) If using PPM mode, check the mode configuration of the remote controller; if using S. BUS mode, check the configuration of the receiver and remote controller.
5) Please check whether the RC connection of the air and ground unit is correct. We provides standard cables. If you make it by yourself, please check the pin.
6) Please check whether the RC mode is configured correctly with Taiysnc PC management software.
7) If above steps cannot solve the problem, please contact Taisync technical support staff.
<b>Q18: After connecting Taisync module, RC can not be connected properly?</b>
Please follow the following steps:
1) Please check whether the link state is normal, please refer to Question 12 and Question 13 if it is abnormal.
2) Please check whether the RC port both the air and the ground units is correct.
3) Please check whether the RC connecting between flight controller and air unit is correct and that between ground unit and remote contriller is correct.
4) If using PPM mode, check the mode configuration of the remote controller; if using S. BUS mode, check the configuration of the receiver and remote controller;
5) Please check whether the RC connection of the air and ground unit is correct. We provides standard cables. If you make it by yourself, please check the pin.
6) Please check whether the RC mode is configured correctly with Taiysnc PC management software.
7) If the above steps can not solve the problem, please contact Taisync technical support staff.

<b>Q19: After connecting Taisync module, video can not be output properly?</b>
Please follow the following steps:
1) Please check whether the link state is normal, please refer to Question 13 and Question 14 if it is abnormal.
2) Please confirm whether the Ethernet physical link and the Ethernet data link indicators are normal, if not, please refer to Question 15 and Question 16(only applicable for ETH ground unit).
3) Please confirm the IP address, login username and password of the used IP camera.
4) Please check whether the IP address configuration of the ground station and the network camera is in the same network segment (only applicable for ETH-ETH scenario).
5) Please confirm PC IP address set as 192.168.0.X, 192.168.0.2 excluded (only applicable for ETH/HDMI-ETH scenario).
6) Please check whether the RTSP video stream configuration for playing RTSP is correct (only applicable for HDMI-ETH scenario).
7) Please check HDMI cable connection or USB to ETH cable connection of ground unit (only applicable for ETH/HDMI-HDMI scenario).
8) If watch video on PC through USB to ETH convertor, make sure PC IP address set as 192.168.199.33 (only applicable for ETH/HDMI-HDMI scenario).
9) If watch video on PC through USB to ETH convertor, make sure video source choose UDP H.264 (only applicable for ETH/HDMI-HDMI scenario).
10) Please check HDMI cable connection of air unit and HDMI camera working properly (only applicable for HDMI-ETH/HDMI scenario).
11) Please try to power on Taisync system first, after Taisync system startup, connecting HDMI camera (only applicable for HDMI-ETH/HDMI scenario).
12) Make sure PC windows firewall is disabled.
13) If above steps cannot solve the problem, please contact Taisync technical support staff.
<b>Q20: After connecting Taisync module, what if the video carton or mosaic?</b>
Please follow the following steps:
1) Please confirm whether the downlink mode configuration is reasonable.
2) Please check whether the connection of HDMI cable/Ethernet cable is normal.
3) Please check if there is interference exists, we can consider changing the working frequency.
4) If there is no interference, whether the limit distance of communication link has been reached.
5) Please check if peak rate of camera is approaching or exceeding the downlink mode setting.
6) Please check real-time downlink rate via Taisync app if there're bi-stream coming out from camera.
7) If above steps cannot solve the problem, please contact Taisync technical support staff.

**Q21: After connecting Taisync module, what if the transmission distance of the module is short, which is not up to expectation?**

Please follow the following steps:

1) Please verify whether the antenna and RF cable are installed correctly, check whether they are Taisync standard materials.

2) Please launch antenna test function through Taisync PC app. If air unit is about 5 meters away from ground unit, RSSI should be -35dBm above.

3) Please ensure that the antennas installation of air unit is not blocked by the payload, and there is no obvious blocking at the ground unit near the antennas, and no contacting with electrical material like carbon fiber and the antennas of the air and ground units are perpendicular to the ground.

4) Please do sanity check of Taisync units to confirm if hardware like PA is damaged.

5) Please check whether the downlink mode configuration is reasonable or not, the high-speed downlink mode will significantly reduce the transmission distance.

6) Please check whether the working frequency is obviously interfered or not, select working frequency properly.

7) Please check whether there is serious obstruction between the air and the ground unit during flight, and the complex geographical environment will affect the transmission distance.

8) If above steps cannot solve the problem, please contact Taisync technical support staff.