

CHARGING SYSTEM

	Page
PRECAUTIONS	CH-2
TROUBLESHOOTING	CH-2
ON-VEHICLE INSPECTION	CH-3
ALTERNATOR	CH-6
ENGINE MAIN RELAY	CH-16

PRECAUTIONS

1. Check that the battery cables are connected to the correct terminals.
2. Disconnect the battery cables when the battery is given a quick charge.
3. Do not perform tests with a high voltage insulation resistance tester.
4. Never disconnect the battery when the engine is running.

TROUBLESHOOTING

Problem	Possible cause	Remedy	Page
Discharge warning light does not light with ignition ON and engine not running	Fuse blown Light burned out Wiring connections loose IC regulator faulty	Check "CHARGE" and "IGN" fuses Replace light Tighten loose connections Replace IC regulator	CH-6
Discharge warning light does not go out with engine running (battery requires frequent recharging)	Drive belt loose or worn Battery cables loose, corroded or worn Fuse blown Fusible link blown IC regulator or alternator faulty Wiring faulty	Adjust or replace drive belt Repair or replace cables Check "ENGINE" fuse Replace fusible link Check charging system Repair wiring	CH-3 CH-4

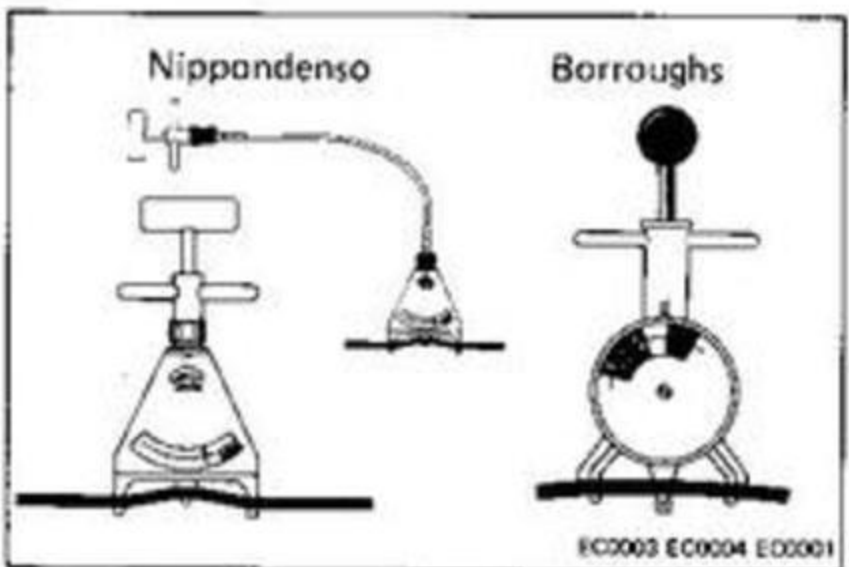
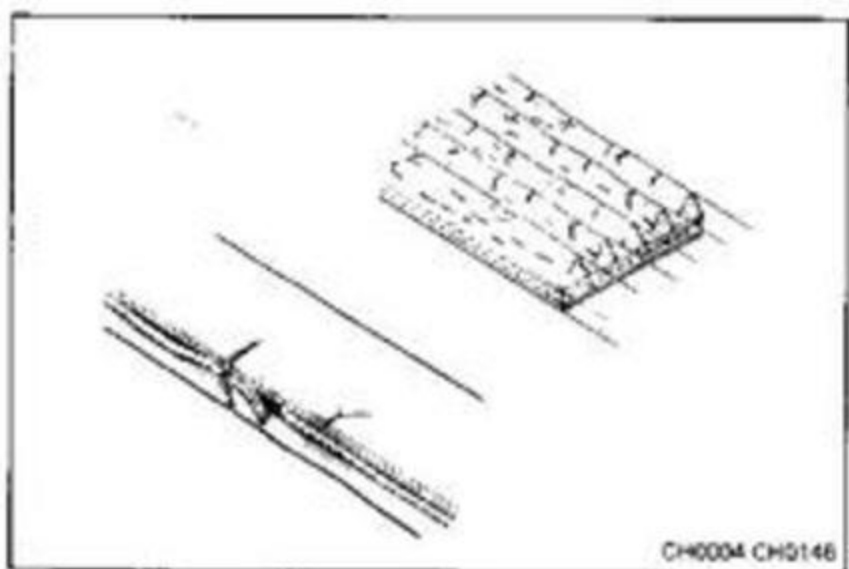
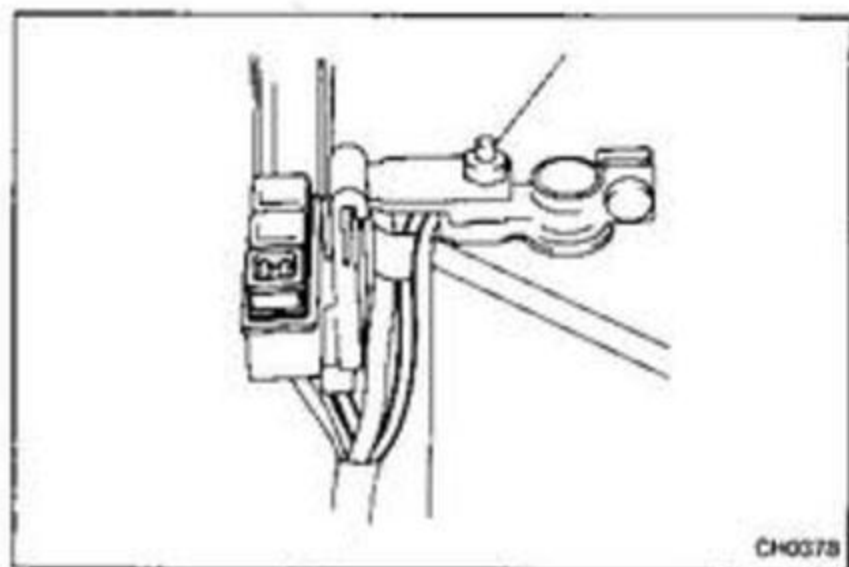
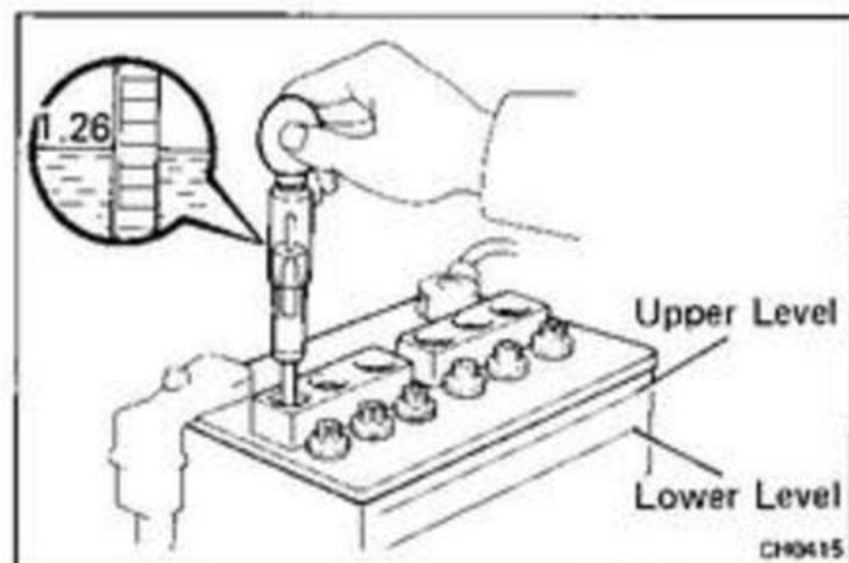

ON-VEHICLE INSPECTION

1. INSPECT BATTERY SPECIFIC GRAVITY AND ELECTROLYTE LEVEL

- (a) Check the specific gravity of each cell.

Standard specific gravity:

1.25 — 1.27 when fully charged at 20°C (68°F)

If not within specifications, charge the battery.

- (b) Check the electrolyte quantity of each cell.

If insufficient, refill with distilled (or purified) water.

2. CHECK BATTERY TERMINALS, FUSIBLE LINKS AND FUSES

- (a) Check that the battery terminals are not loose or corroded.

- (b) Check the fusible links and fuses for continuity.

Fusible link: ALT 80A
AM1 40A
AM2 30A

Fuse: ENGINE 10A
CHARGE 7.5A
IGN 7.5A

3. INSPECT DRIVE BELT

- (a) Visually check the belt for separation of the adhesive rubber above and below the core, core separation from the belt side, a severed core, separation of the rib from the adhesive rubber, cracking or separation of the ribs, torn or worn ribs or cracks in the inner ridges of the ribs.

If the belt has any of the above defects, replace it.

- (b) Using a belt tension gauge, measure the drive belt tension.

Belt tension gauge:

Nippondenso BTG-20 (95506-00020)

Borroughs No. BT-33-73F

Drive belt tension:

3S-FE	w/	Air con.	New belt	175 ± 5 lb
			Used belt	130 ± 10 lb
	w/o	Air con.	New belt	125 ± 25 lb
			Used belt	95 ± 20 lb
3S-GE	w/	Air con.	New belt	175 ± 5 lb
			Used belt	115 ± 20 lb
	w/o	Air con.	New belt	150 ± 25 lb
			Used belt	130 ± 25 lb

If the belt tension is not as specified, adjust it.

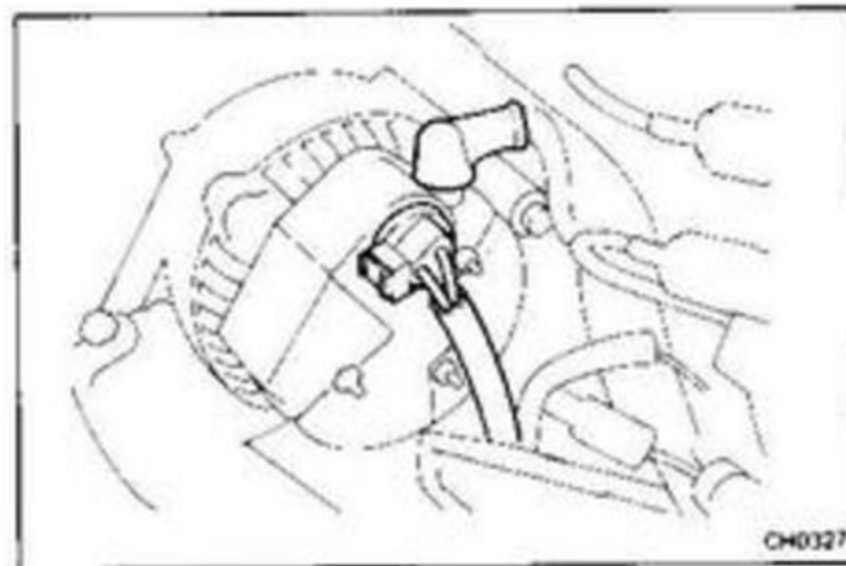
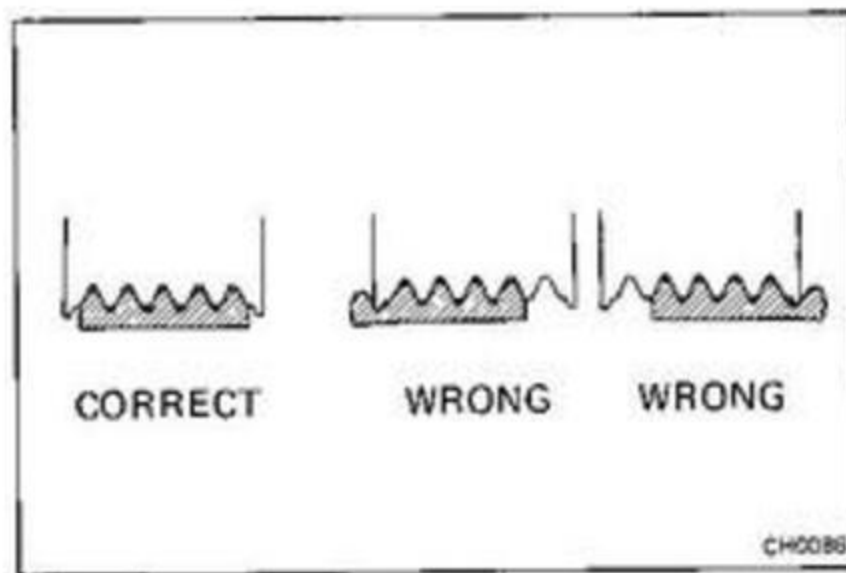

NOTE:

- "New belt" refer to a belt which has been used 5 minutes or less on a running engine.
- "Used belt" refers to a belt which has been used on a running engine for 5 minutes or more.
- After installing a belt, check that it fits properly in the ribbed grooves.
- Check by hand to confirm that the belt has not slipped out of the groove on the bottom of the pulley.
- After installing a new belt, run the engine for about 5 minutes and recheck the belt tension.

4. VISUALLY CHECK ALTERNATOR WIRING AND LISTEN FOR ABNORMAL NOISES

- Check that the wiring is in good condition.
- Check that there is no abnormal noise from the alternator while the engine is running.

5. INSPECT CHARGE WARNING LIGHT CIRCUIT

- Warm up the engine and then turn it off.
- Turn off all accessories.
- Turn the ignition switch to "ON". Check that the charge warning light is lit.
- Start the engine. Check that the light goes out.

If the light does not go off as specified, troubleshoot the charge light circuit.

6. INSPECT CHARGING CIRCUIT WITHOUT LOAD

NOTE: If a battery/alternator tester is available, connect the tester to the charging circuit as per manufacturer's instructions.

- If a tester is not available, connect a voltmeter and ammeter to the charging circuit as follows:
 - Disconnect the wire from terminal B of the alternator and connect it to the negative (\ominus) probe of the ammeter.
 - Connect the positive (\oplus) probe of the ammeter to terminal B of the alternator.
 - Connect the positive (\oplus) probe of the voltmeter to terminal B of the alternator.
 - Ground the negative (\ominus) probe of the voltmeter.

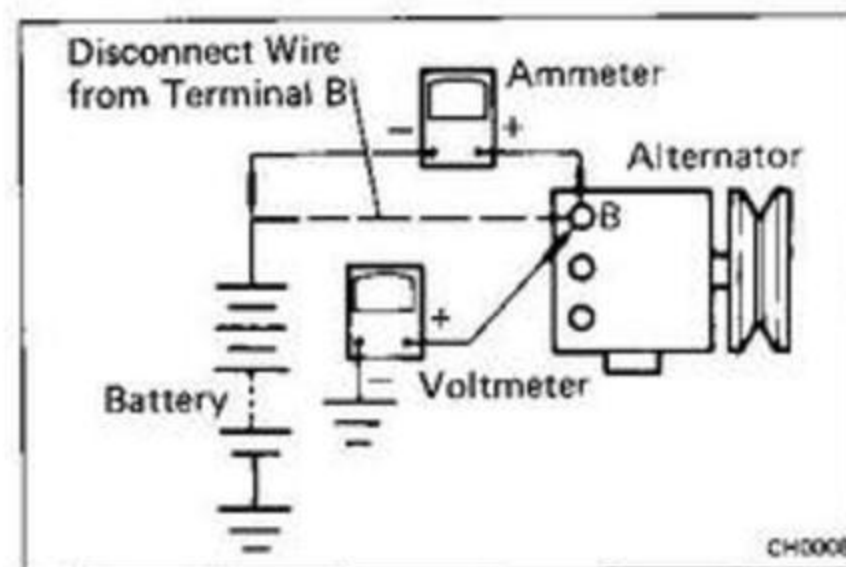

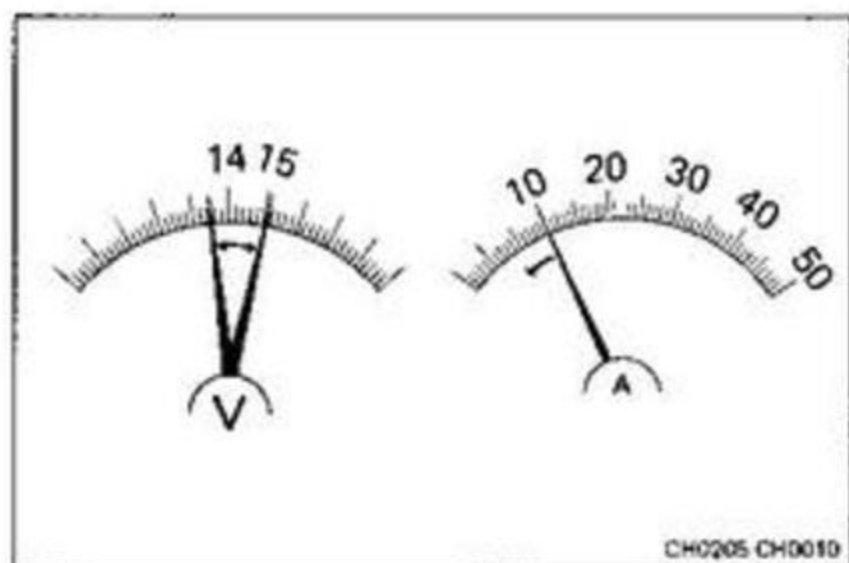

- (b) Check the charging circuit as follows:
With the engine running from idling to 2,000 rpm, check the reading on the ammeter and voltmeter.

Standard amperage: 10 A or less

Standard voltage: 13.5 – 15.1 V at 25°C (77°F)

If the voltmeter reading is greater than standard voltage, replace the IC regulator.

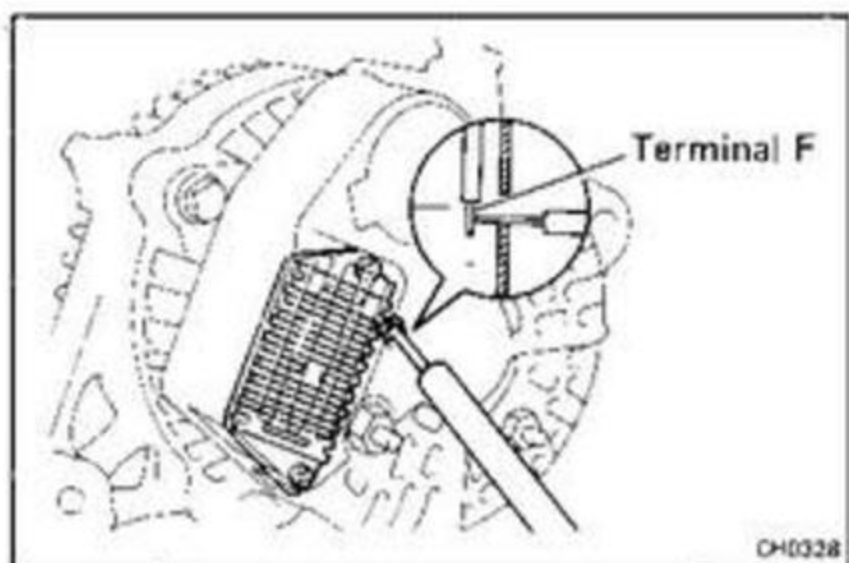

If the voltmeter reading is less than standard voltage, check the IC regulator and alternator as follows:

- With terminal F grounded, start the engine and check the voltmeter reading of terminal B.

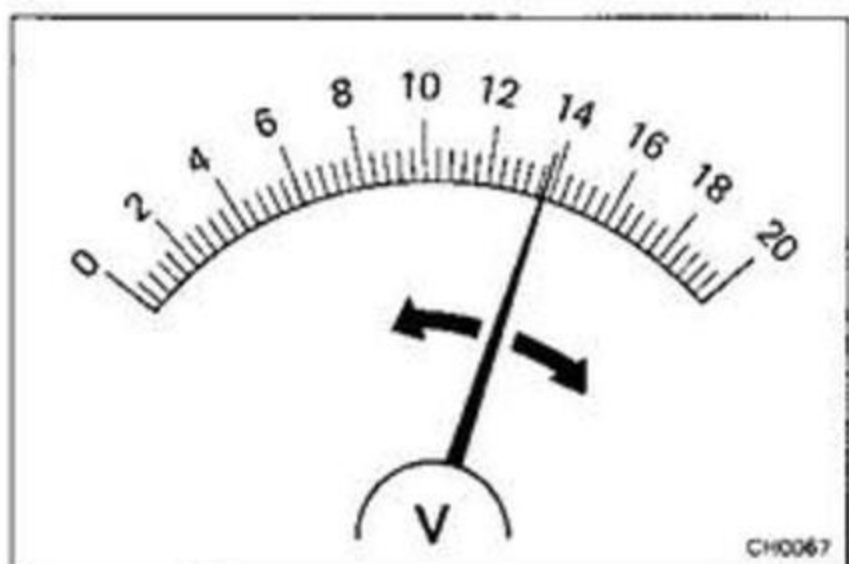

- If the voltmeter reading is greater than standard voltage, replace the IC regulator.
- If the voltmeter reading is less than standard voltage, check the alternator.

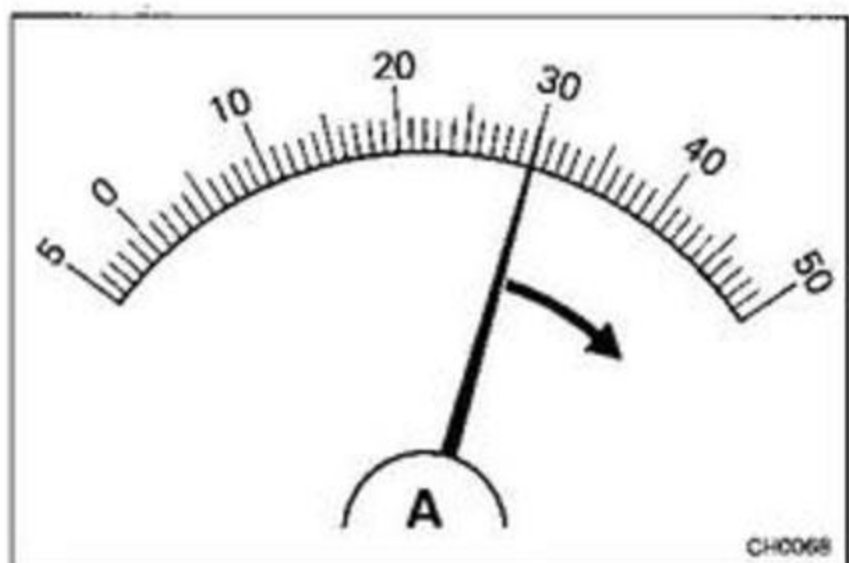

7. INSPECT CHARGING CIRCUIT WITH LOAD

- (a) With the engine running at 2,000 rpm, turn on the high beam headlights and place the heater blower switch at "HI".

- (b) Check the reading on the ammeter.

Standard amperage: 30 A or more

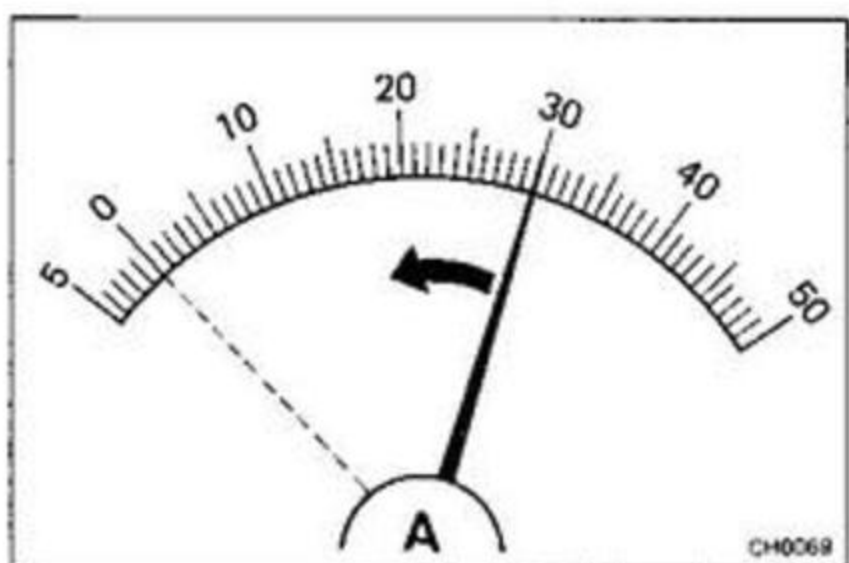

If the ammeter reading is less than standard amperage, repair the alternator. (See page CH-6)

NOTE: With the battery fully charged, the indication will sometimes be less than standard amperage.

ALTERNATOR COMPONENTS

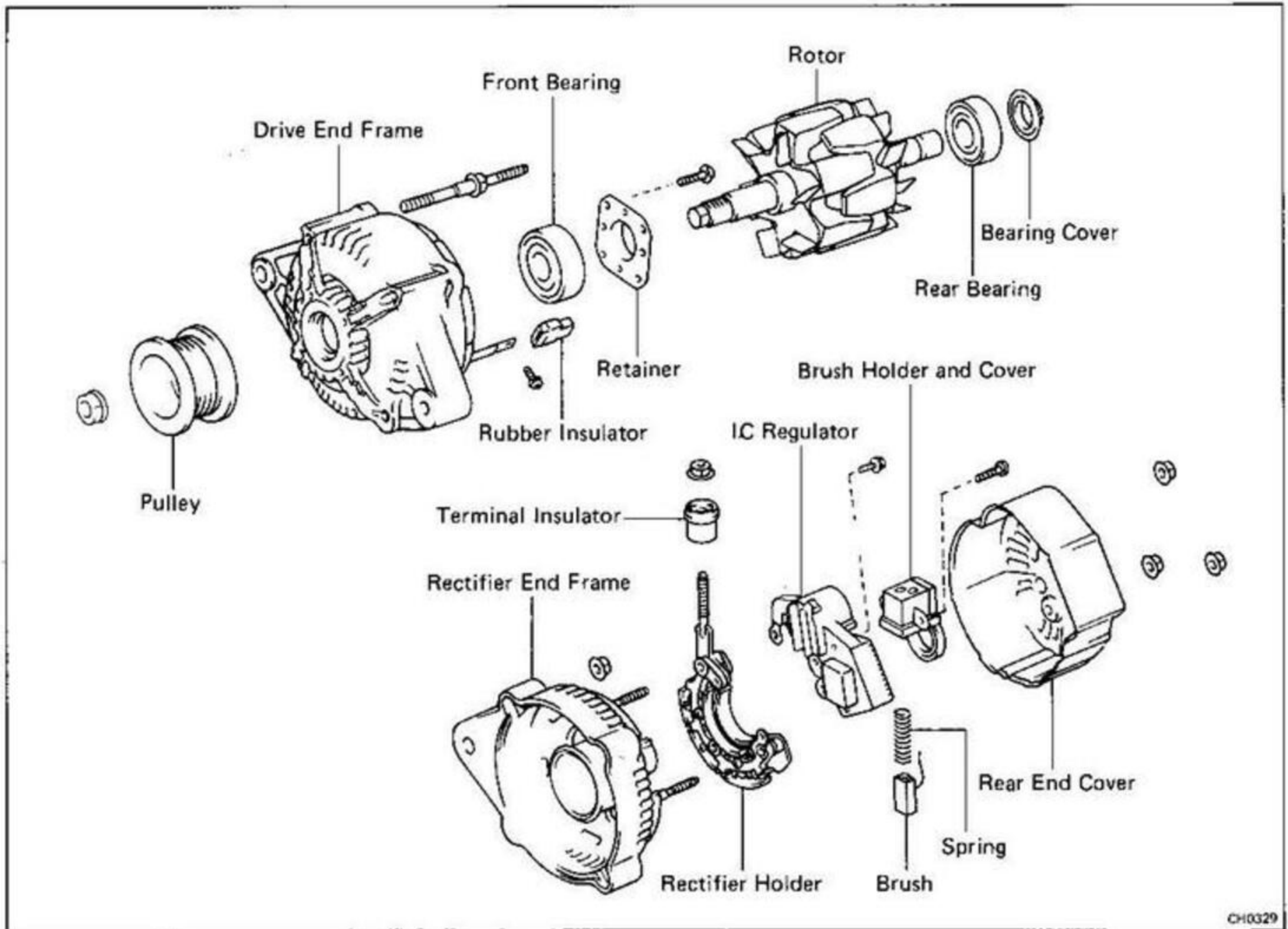

CH0329

REMOVAL OF ALTERNATOR

1. DISCONNECT CABLE FROM NEGATIVE TERMINAL OF BATTERY
2. DISCONNECT CONNECTOR AND WIRE
 - (a) Alternator connector
 - (b) Alternator wire
 - (c) (3S-GE)
A/C compressor connectors
 - (d) (3S-GE)
Water temperature switch connector
3. REMOVE DRIVE BELT

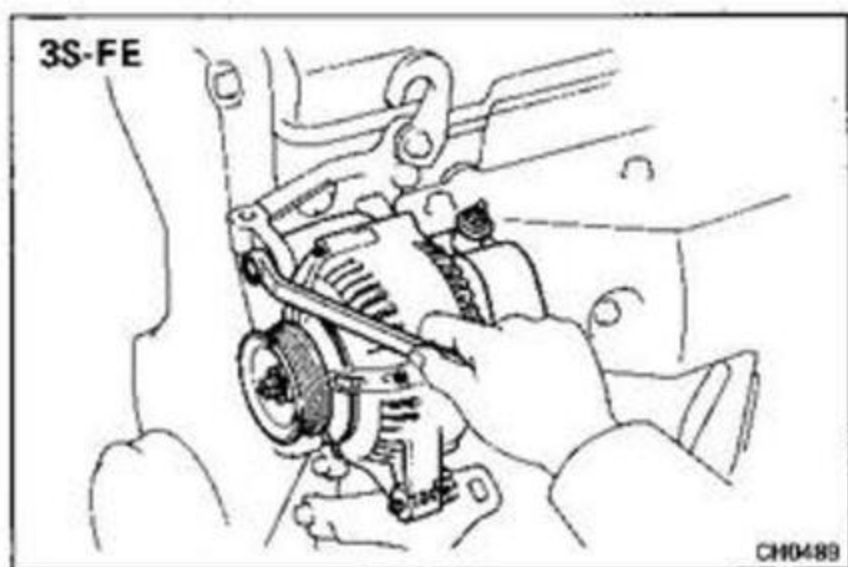
**4. REMOVE ALTERNATOR**

(3S-FE)

Remove the adjusting lock bolt, pivot bolt and alternator.

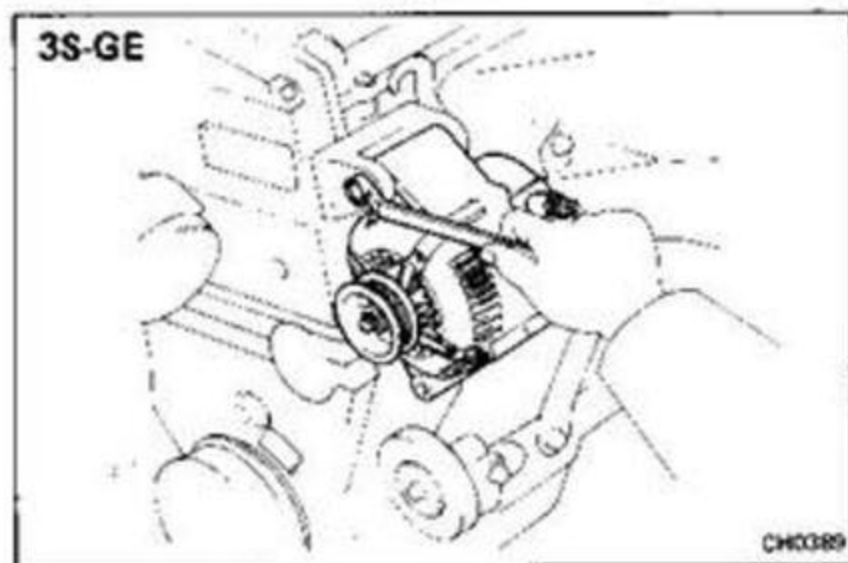

(3S-GE)

Remove the two bolts and alternator.

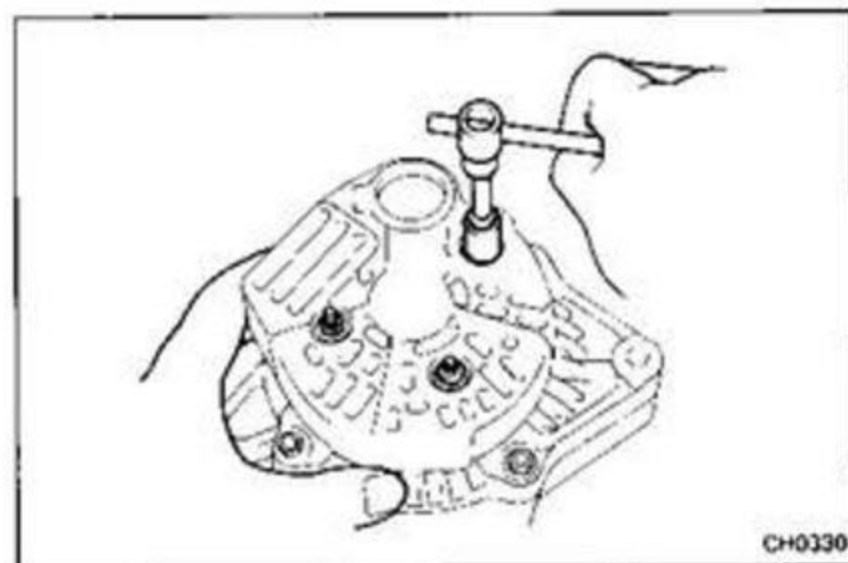
**DISASSEMBLY OF ALTERNATOR**

(See page CH-6)

1. REMOVE REAR END COVER

- (a) Remove the nut and terminal insulator.
- (b) Remove the three nuts and end cover.

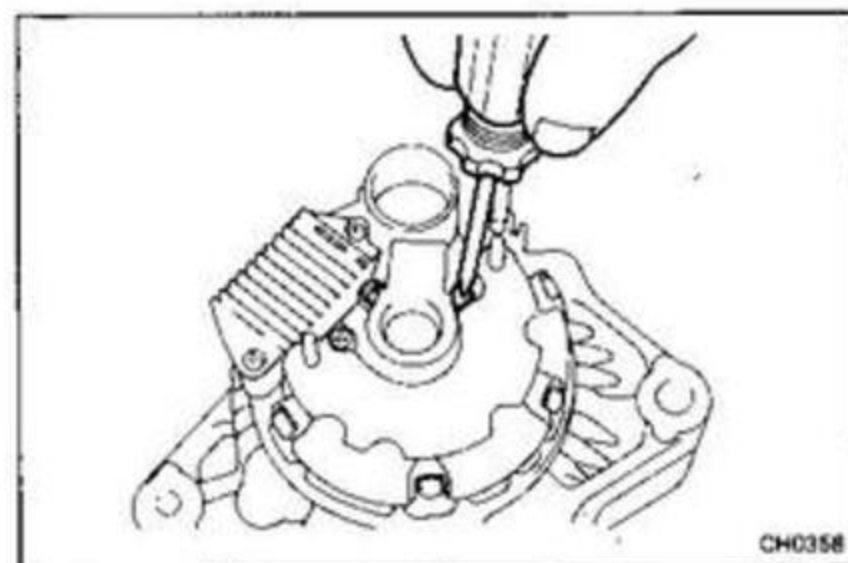
**2. REMOVE BRUSH HOLDER AND IC REGULATOR**

Remove the five screws, brush holder and IC regulator.

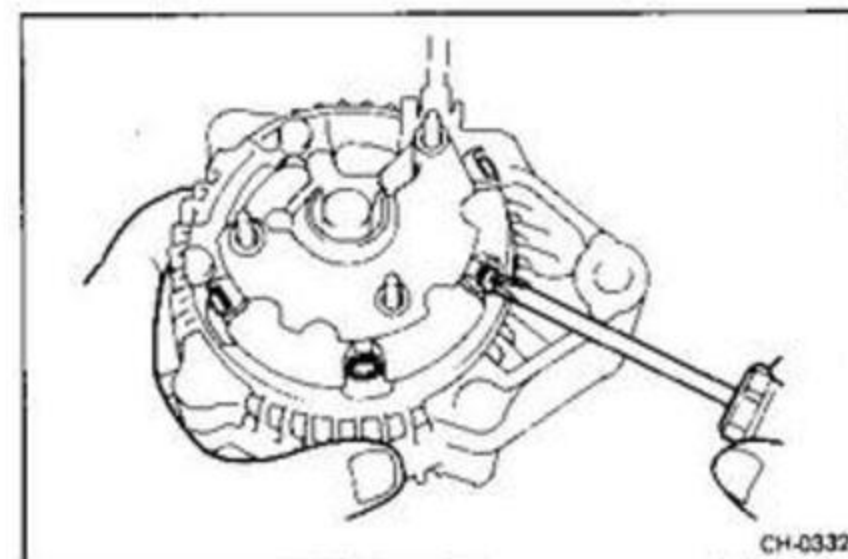
**3. REMOVE RECTIFIER HOLDER**

- (a) Remove the four screws and rectifier holder.
- (b) Remove the four rubber insulators.

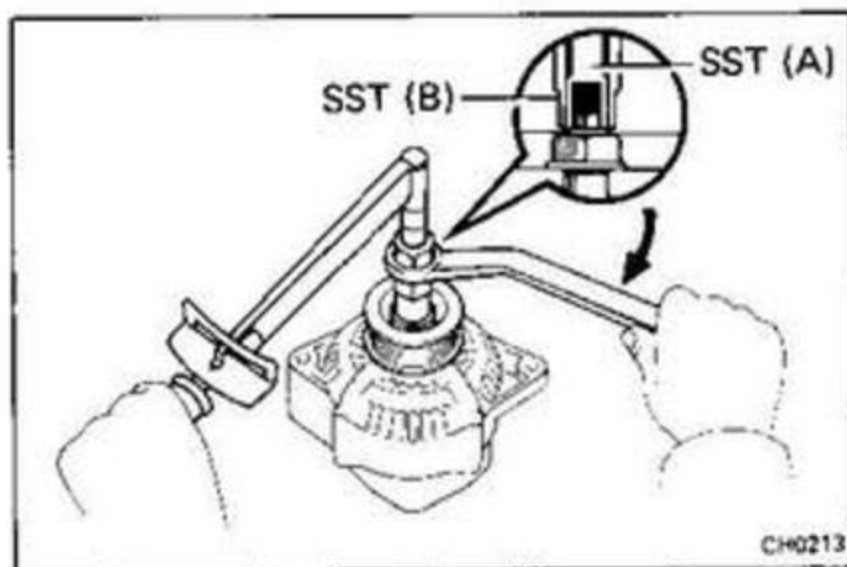

4. REMOVE PULLEY

- (a) Hold SST (A) with a torque wrench, and tighten SST (B) clockwise to the specified torque.

SST 09820-63010

Torque: 400 kg-cm (29 ft-lb, 39 N·m)

- (b) Check that SST (A) is secured to the rotor shaft.

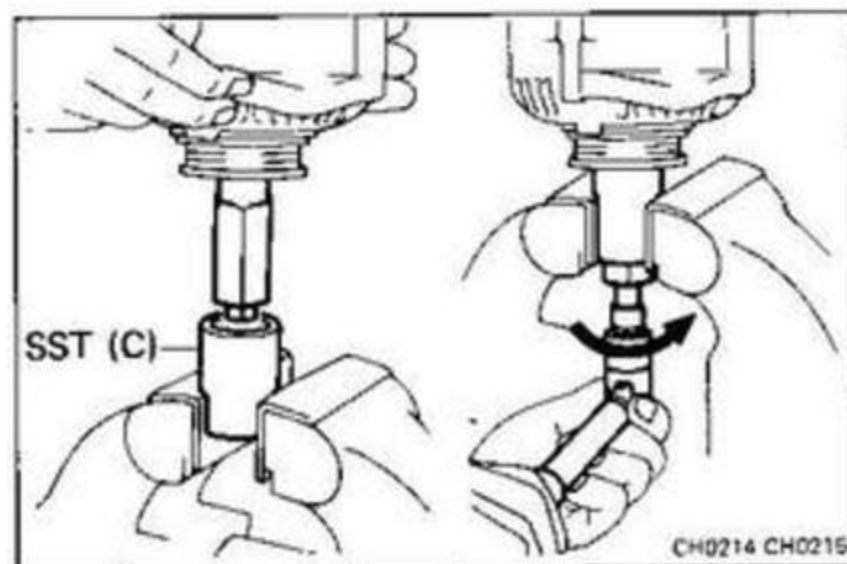

- (c) As shown in the figure, mount SST (C) in a vise, and install the alternator to SST (C).

- (d) To loosen the pulley nut turn SST (A) in the direction shown in the figure.

CAUTION: To prevent damage to the rotor shaft, do not loosen the pulley nut more than one-half of a turn.

- (e) Remove the alternator from SST (C).

- (f) Turn SST (B) and remove SST (A and B).

- (g) Remove the pulley nut and pulley.

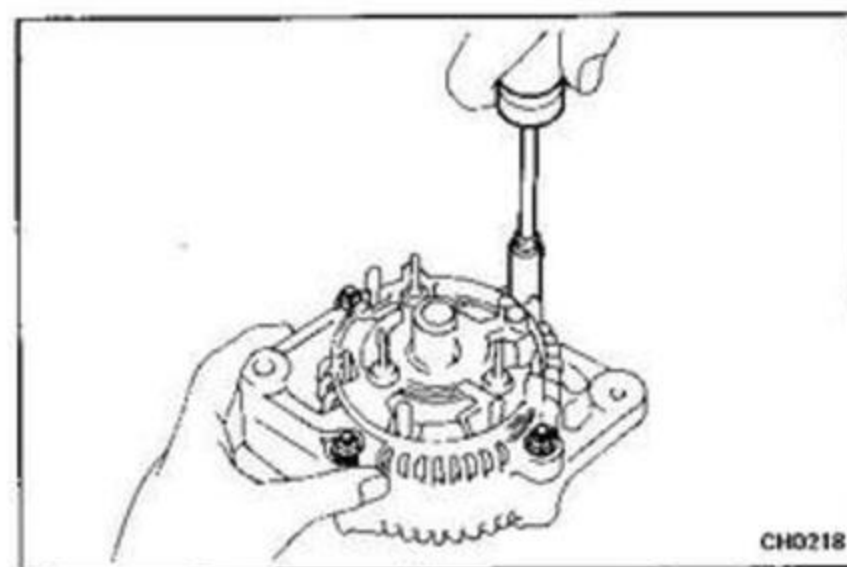

5. REMOVE RECTIFIER END FRAME

- (a) Remove the four nuts.

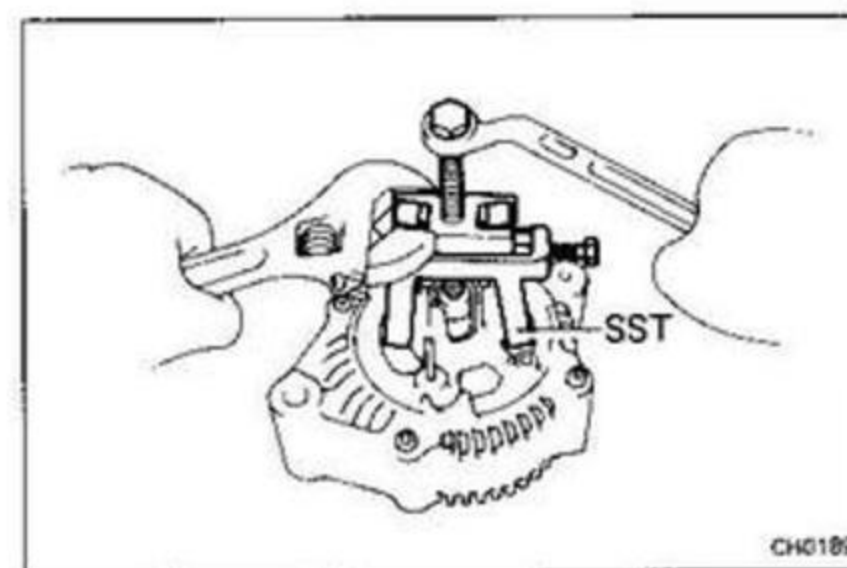

- (b) Using SST, remove the rectifier end frame.

SST 09286-46011

6. REMOVE ROTOR FROM DRIVE END FRAME

INSPECTION AND REPAIR OF ALTERNATOR**Rotor****1. INSPECT ROTOR FOR OPEN CIRCUIT**

Using an ohmmeter, check that there is continuity between the slip rings.

Standard resistance(Cold): 2.8 – 3.0 Ω

If there is no continuity, replace the rotor.

2. INSPECT ROTOR FOR GROUND

Using an ohmmeter, check that there is no continuity between the slip ring and rotor.

If there is continuity, replace the rotor.

3. INSPECT SLIP RINGS

(a) Check that the slip rings are not rough or scored. If rough or scored, replace the rotor.

(b) Using calipers, measure the slip ring diameter.

**Standard diameter: 14.2 – 14.4 mm
(0.559 – 0.567 in.)**

Minimum diameter: 12.8 mm (0.504 in.)

If the diameter is less than minimum, replace the rotor.

Stator**1. INSPECT STATOR FOR OPEN CIRCUIT**

Using an ohmmeter, check that there is continuity between the coil leads.

If there is no continuity, replace the drive end frame assembly.

2. INSPECT STATOR FOR GROUND

Using an ohmmeter, check that there is no continuity between the coil lead and drive end frame.

If there is continuity, replace the drive end frame assembly.

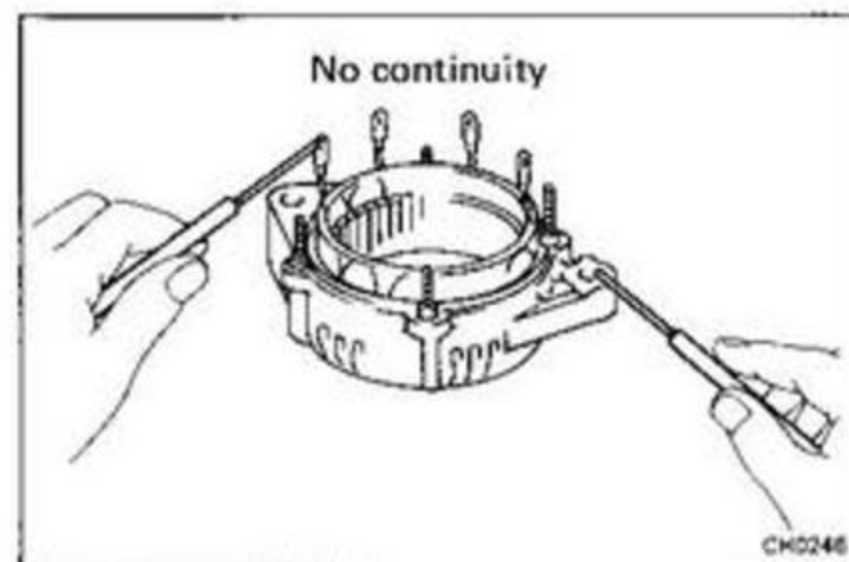
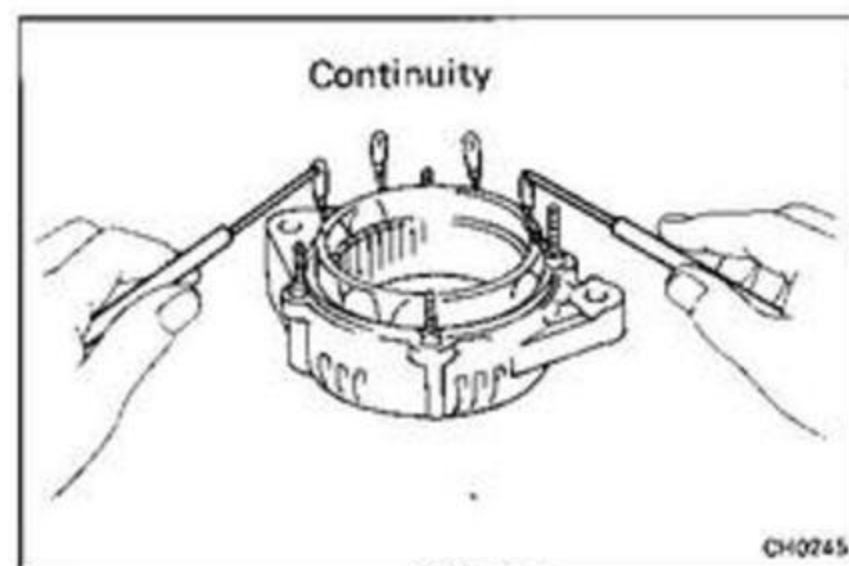
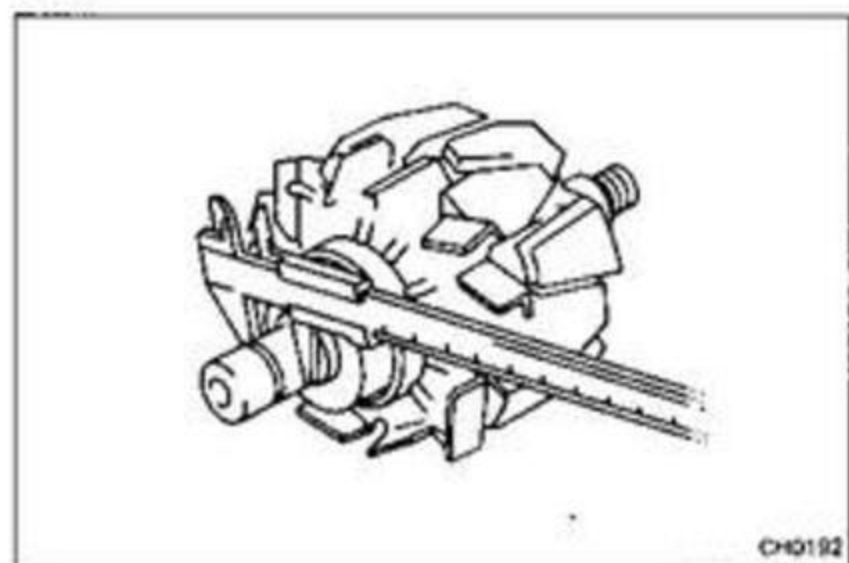
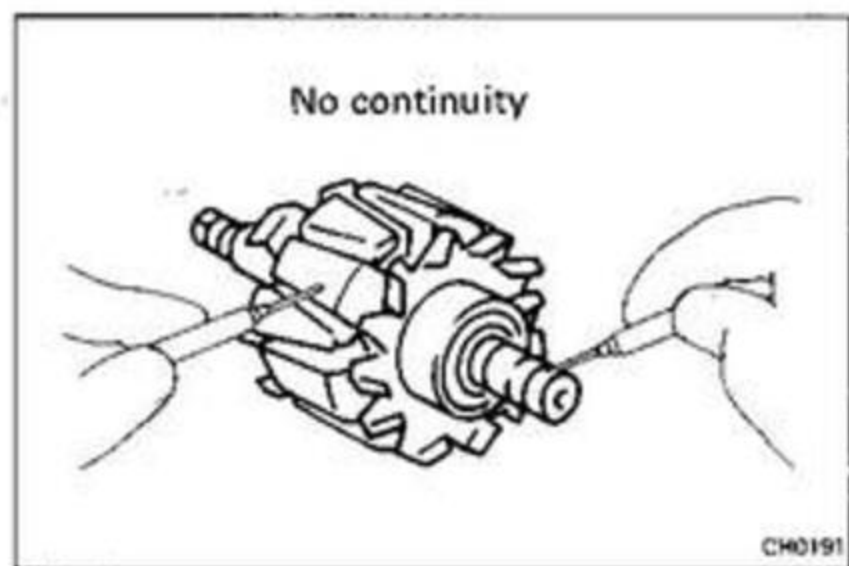
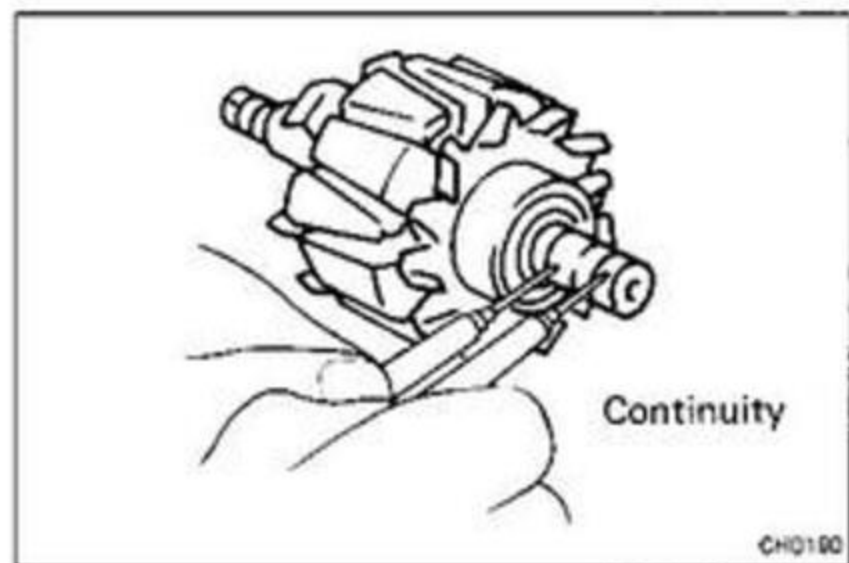

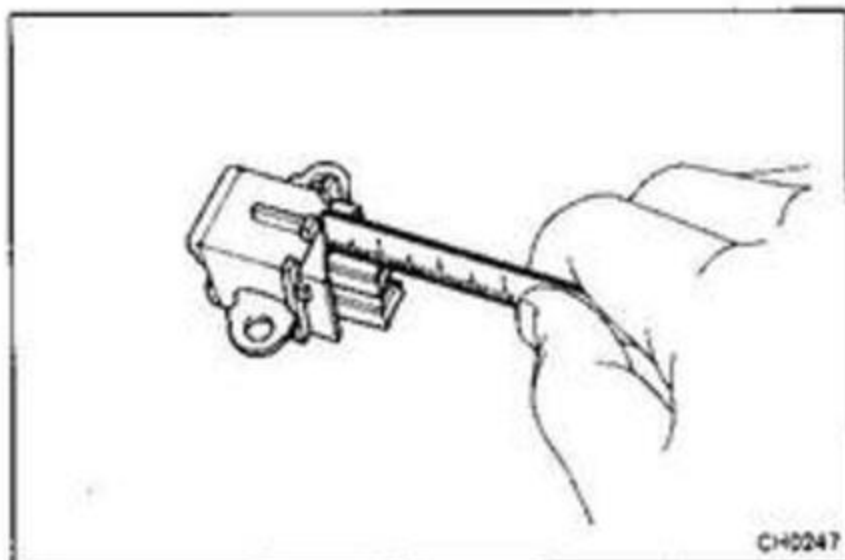

Brushes

1. INSPECT EXPOSED BRUSH LENGTH

Using a scale, measure the exposed brush length.

Standard exposed length: 10.5 mm (0.413 in.)

Minimum exposed length: 1.5 mm (0.059 in.)

If the exposed length is less than minimum, replace the brushes.

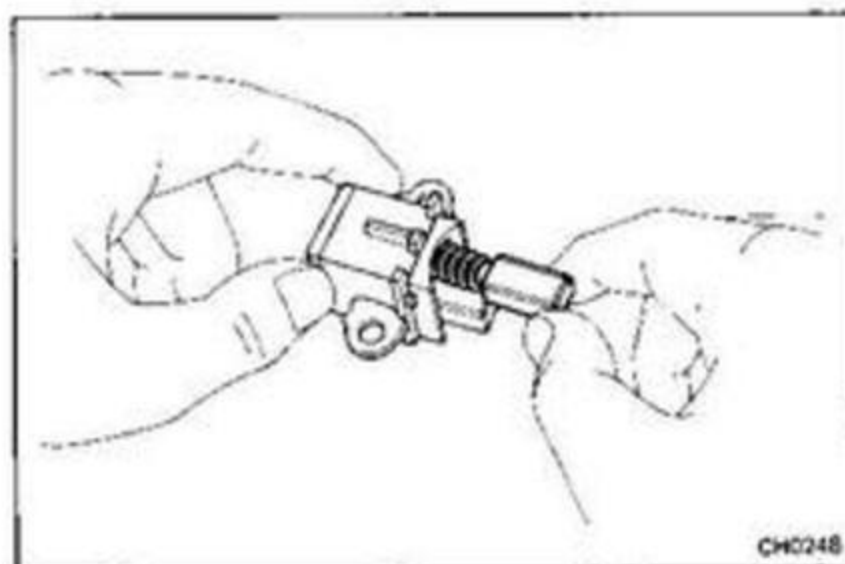

2. IF NECESSARY, REPLACE BRUSHES

(a) Unsolder and remove the brush and spring.

(b) Run the wire of a new brush through the hole in the brush holder, and insert the spring and brush into the brush holder.

(c) Solder the brush wire to the brush holder at specified exposed length.

Exposed length: 10.5 mm (0.413 in.)

(d) Check that the brush moves smoothly in the brush holder.

(e) Cut off the excess wire.

(f) Apply insulation paint to the soldered point.

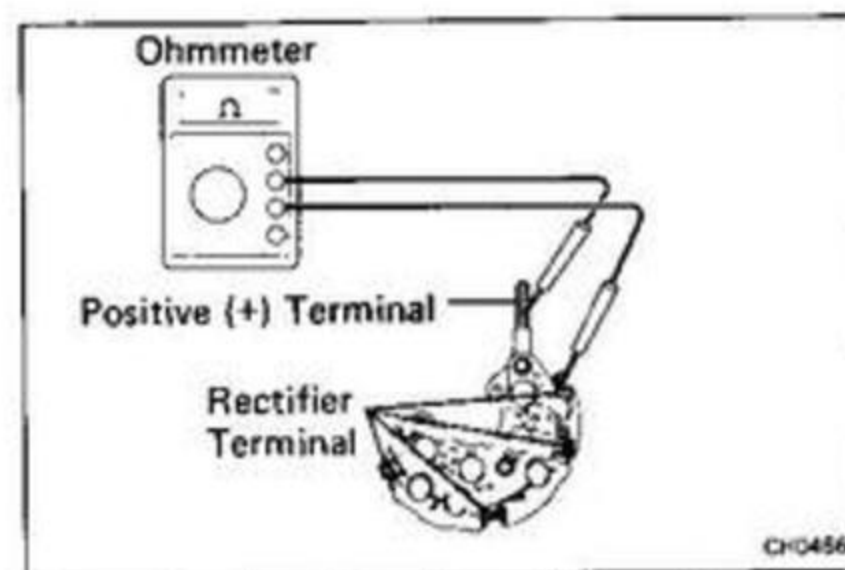
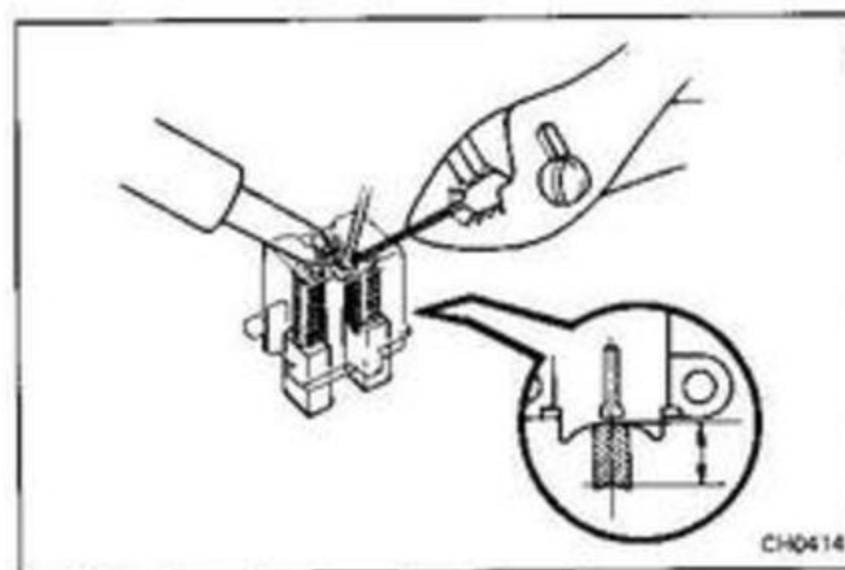

Rectifiers (Rectifier Holder)

1. INSPECT POSITIVE RECTIFIER

(a) Connect the ohmmeter positive (+) probe to each rectifier terminal and the negative (-) probe to the positive (+) terminal, and check that there is no continuity.

(b) Reverse the ohmmeter probes, and check that there is continuity.

If continuity is not as specified, replace the rectifier holder.

2. INSPECT NEGATIVE RECTIFIER

(a) Connect the ohmmeter positive (+) probe to each rectifier terminal and the negative (-) probe to each negative (-) terminal, check that there is continuity.

(b) Reverse the ohmmeter probes, and check that there is no continuity.

If continuity is not as specified, replace the rectifier holder.

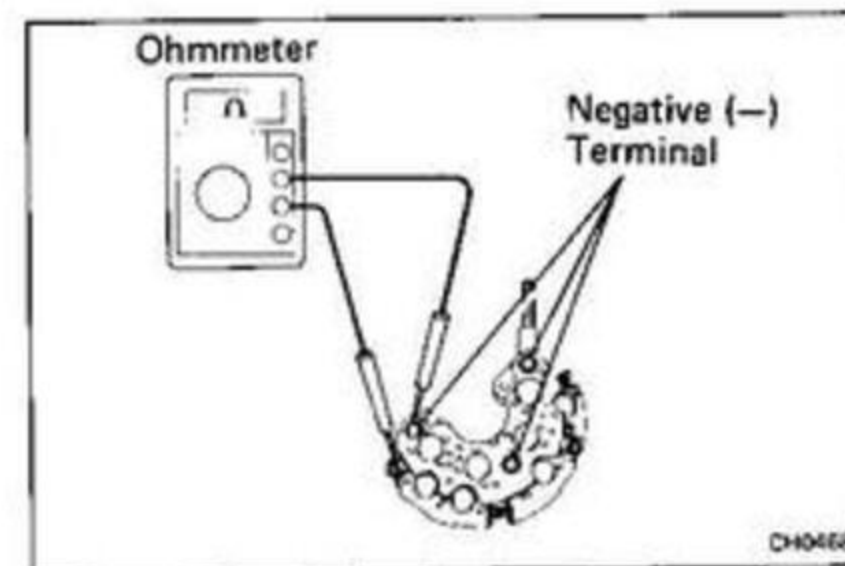

Bearings

1. INSPECT FRONT BEARING

Check that the bearing is not rough or worn.

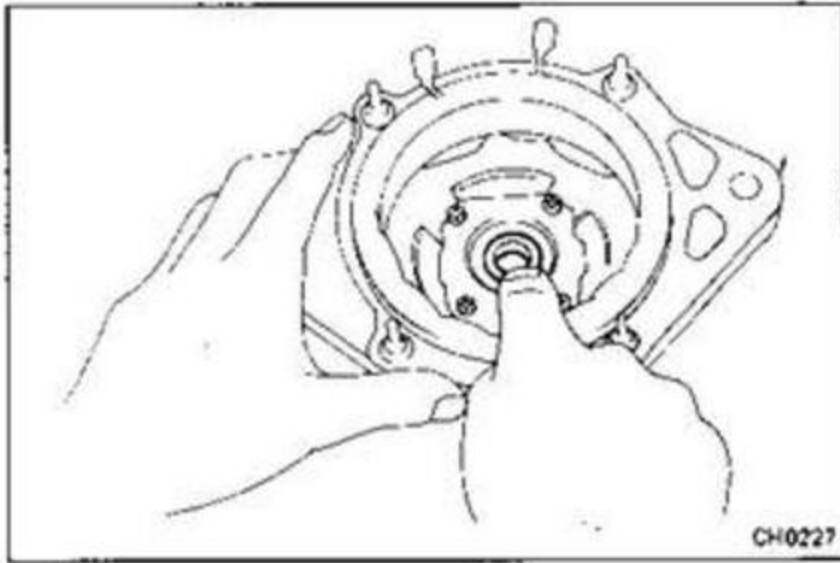

2. IF NECESSARY, REPLACE FRONT BEARING

(a) Remove the four screws, bearing retainer and bearing.

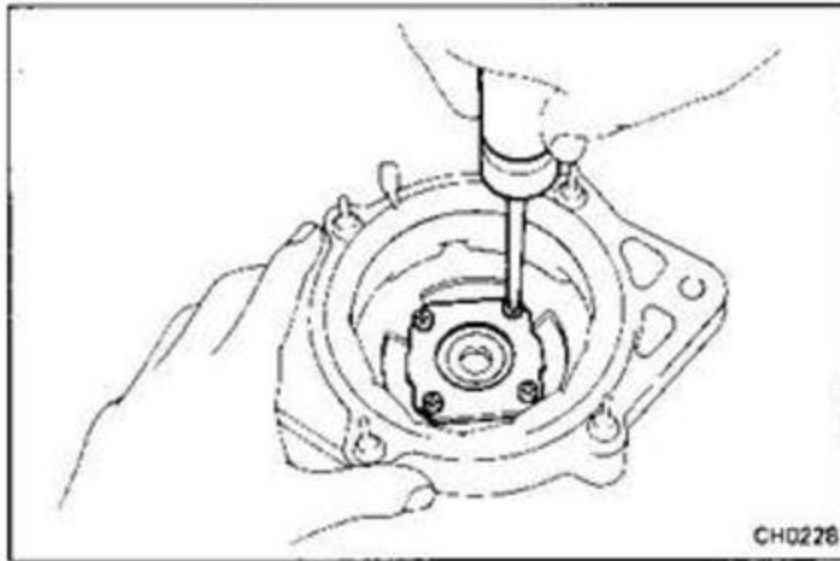

(b) Using a socket wrench and press, press out the bearing.

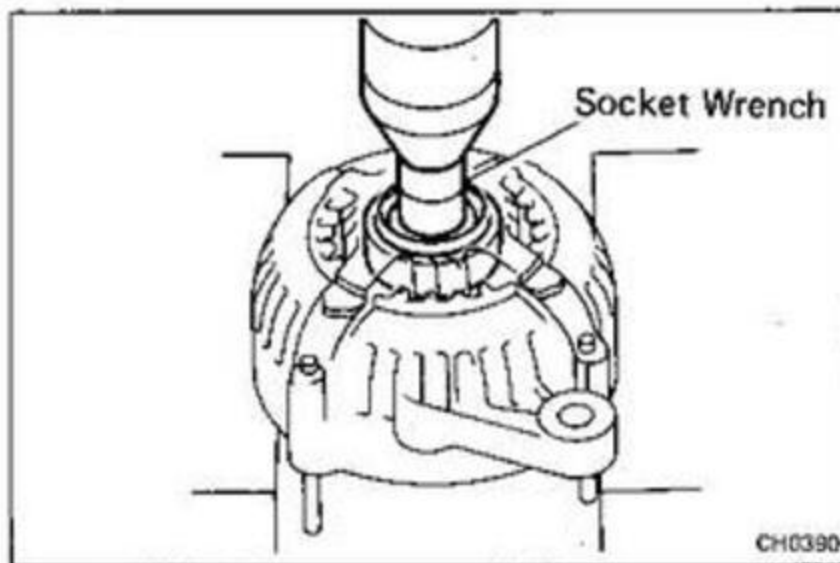

(c) Using SST and a press, press in a new bearing.
SST 09608-20012 (09608-00030)

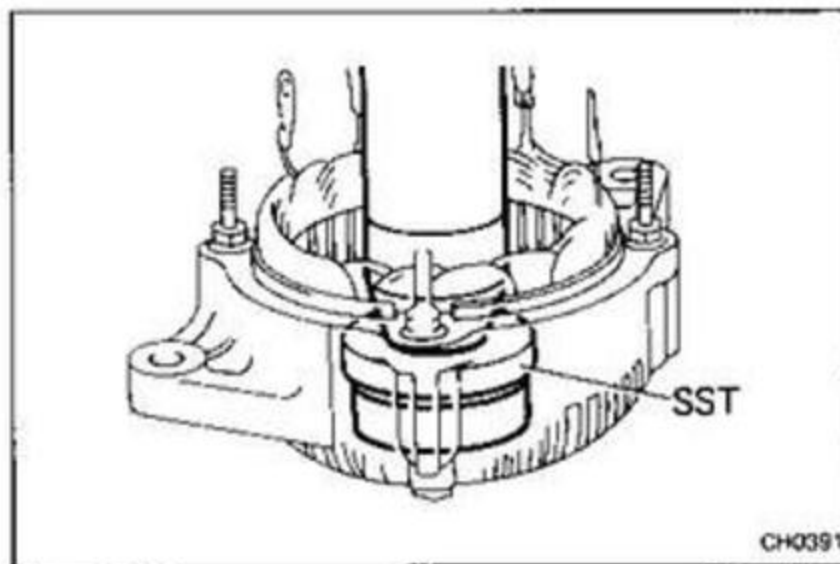

(d) Install the bearing retainer with the four screws.

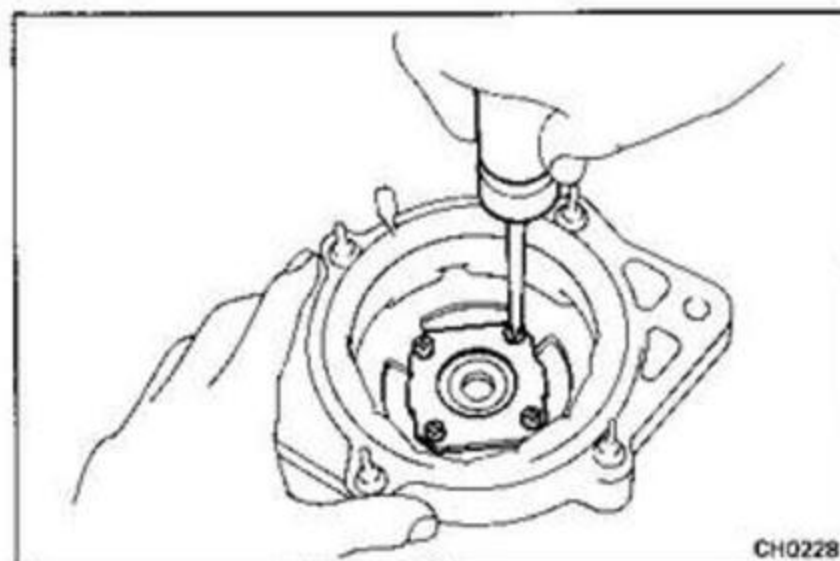

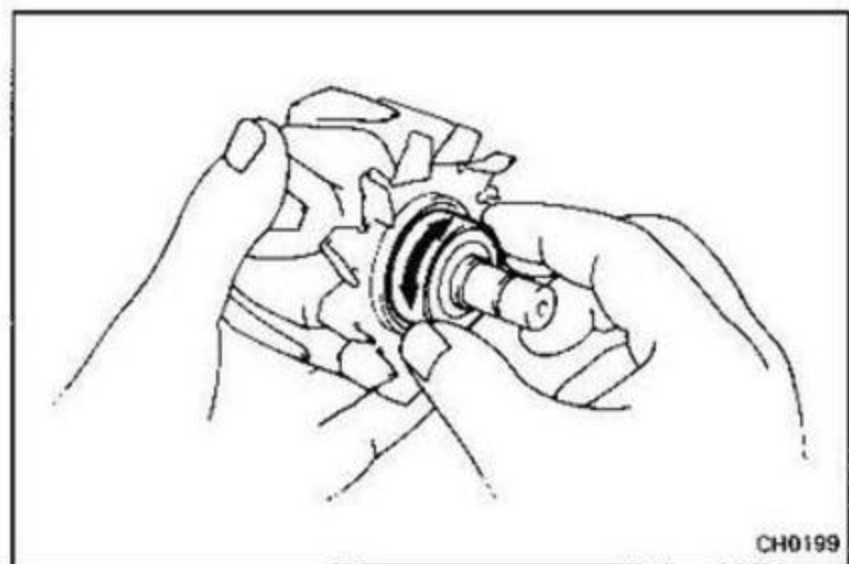
**3. INSPECT REAR BEARING**

Check that the bearing is not rough or worn.

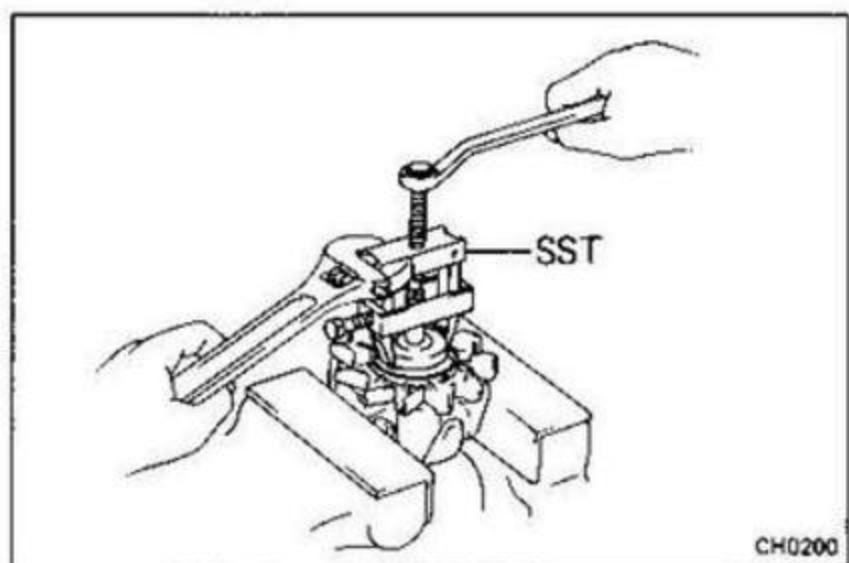
**4. IF NECESSARY, REPLACE REAR BEARING**

(a) Using SST, remove the bearing cover and bearing.

SST 09820-00021

CAUTION: Be careful not to damage the fan.

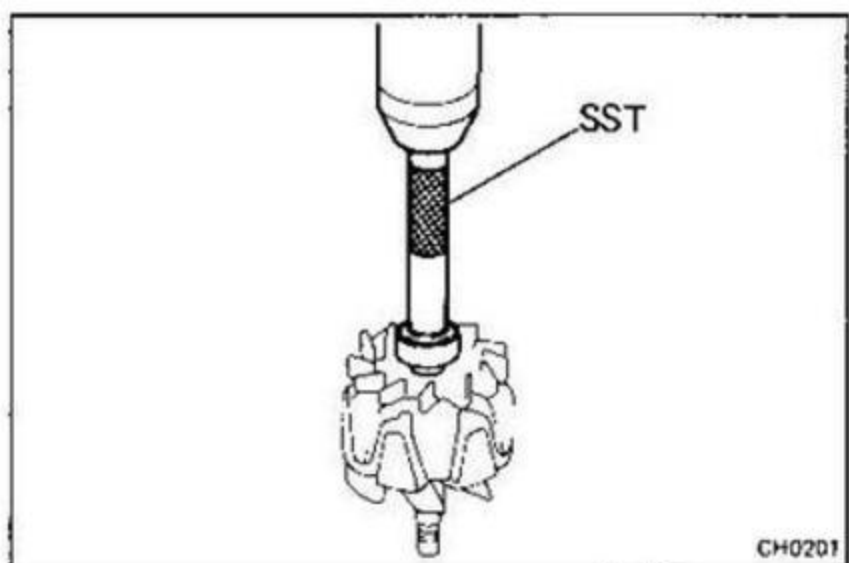

(b) Using SST and a press, press in a new bearing and bearing cover.

SST 09285-76010

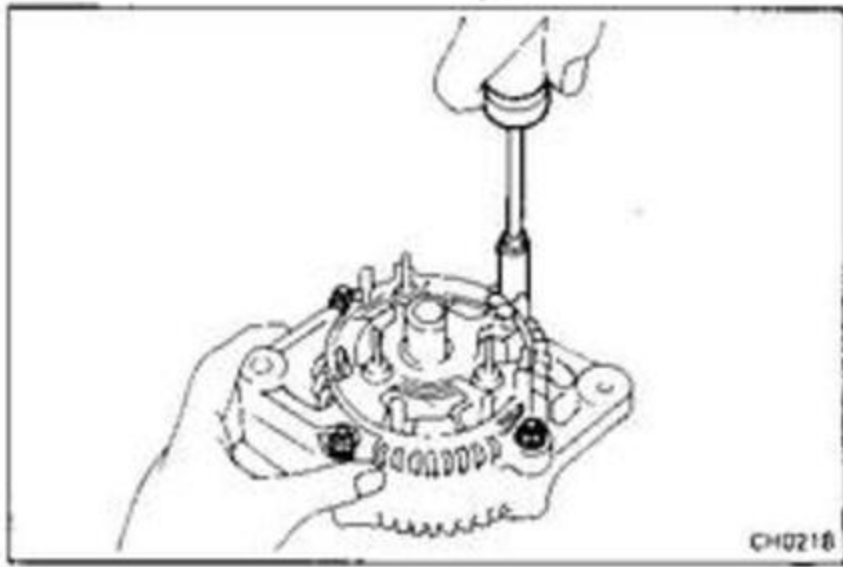

ASSEMBLY OF ALTERNATOR

(See page CH-6)

1. **INSTALL ROTOR TO DRIVE END FRAME**
2. **ASSEMBLE DRIVE END FRAME AND RECTIFIER END FRAME**

- (a) Using a plastic-faced hammer, lightly tap in the end frame.
- (b) Install the four nuts.

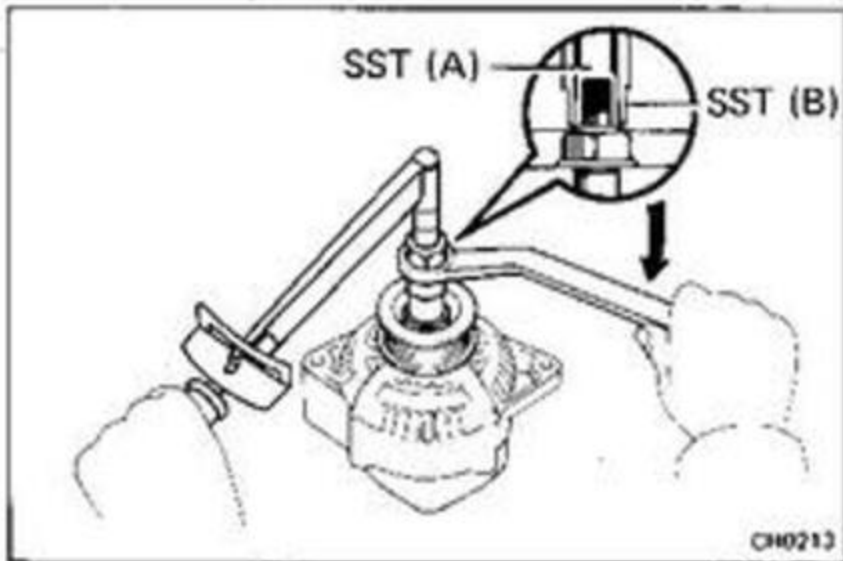

3. **INSTALL PULLEY**

- (a) Install the pulley to the rotor shaft by tightening the pulley nut by hand.
- (b) Hold SST (A) with a torque wrench, and tighten SST (B) clockwise to the specified torque.

SST 09820-63010

Torque: 400 kg-cm (29 ft-lb, 39 N·m)

- (c) Check that SST (A) is secured to the pulley shaft.

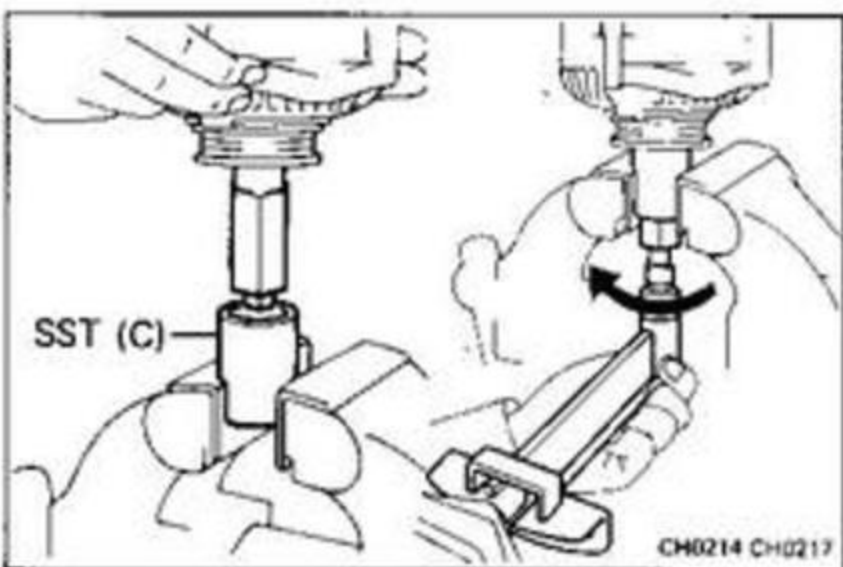

- (d) As shown in the figure, mount SST (C) in a vise, and install the alternator to SST (C).

- (e) To torque the pulley nut turn SST (A) in the direction shown in the figure.

Torque: 1,125 kg-cm (81 ft-lb, 110 N·m)

- (f) Remove the alternator from SST (C).
- (g) Turn SST (B) and remove SST (A and B).

4. **INSTALL RECTIFIER HOLDER**

- (a) Install the four rubber insulators on the lead wires.

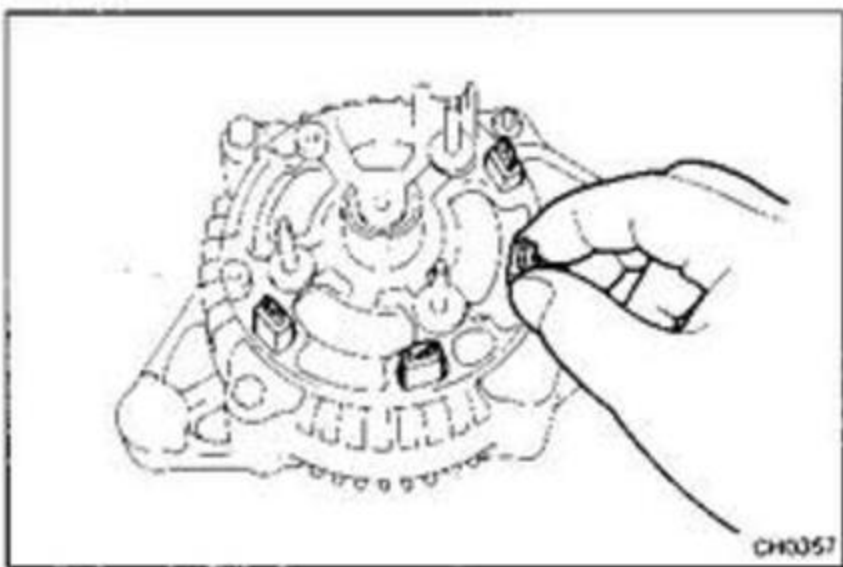

- (b) Install the rectifier holder with the four screws.

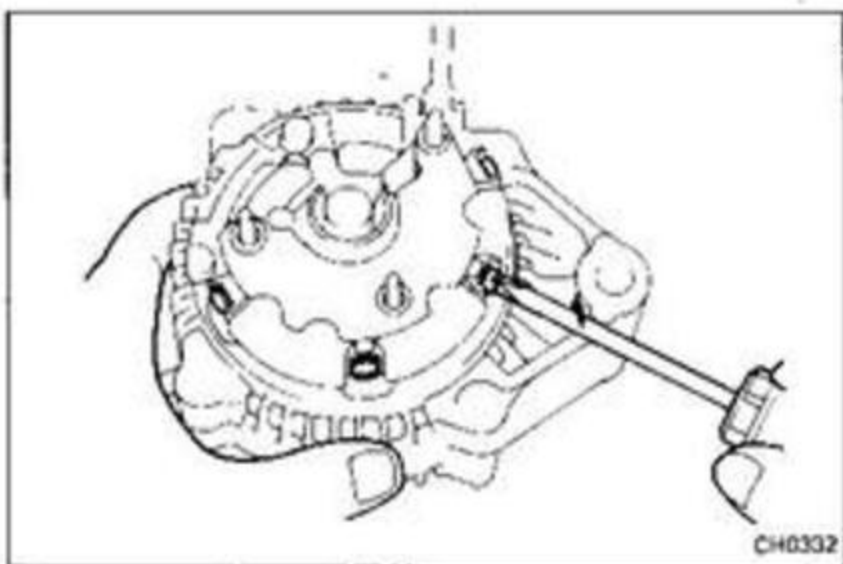

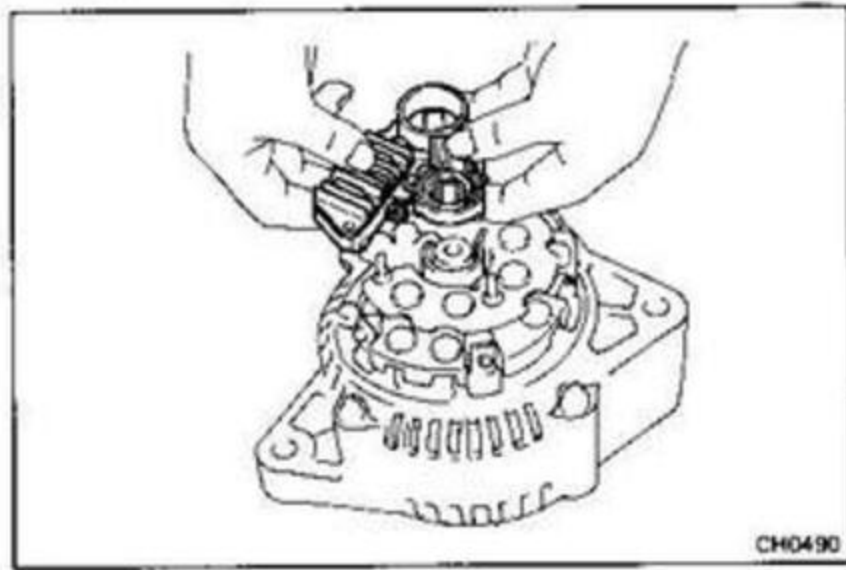

5. INSTALL IC REGULATOR AND BRUSH HOLDER

- (a) Install the brush holder cover to the brush holder.
- (b) Install the IC regulator together with the brush holder horizontally as shown.

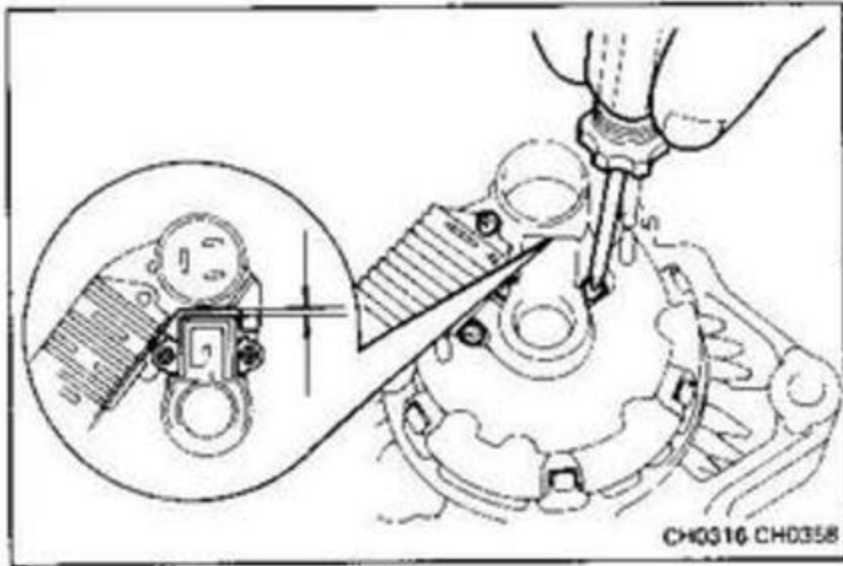

- (c) Install the five screws until there is a clearance of approx. 1 mm (0.04 in.) between the brush holder and connector.

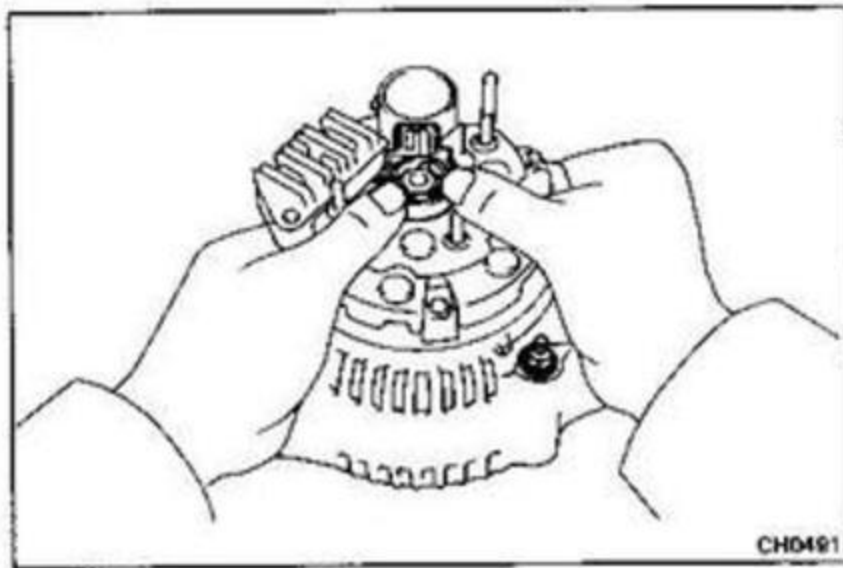

- (d) Fit the brush holder cover.

6. INSTALL REAR END COVER

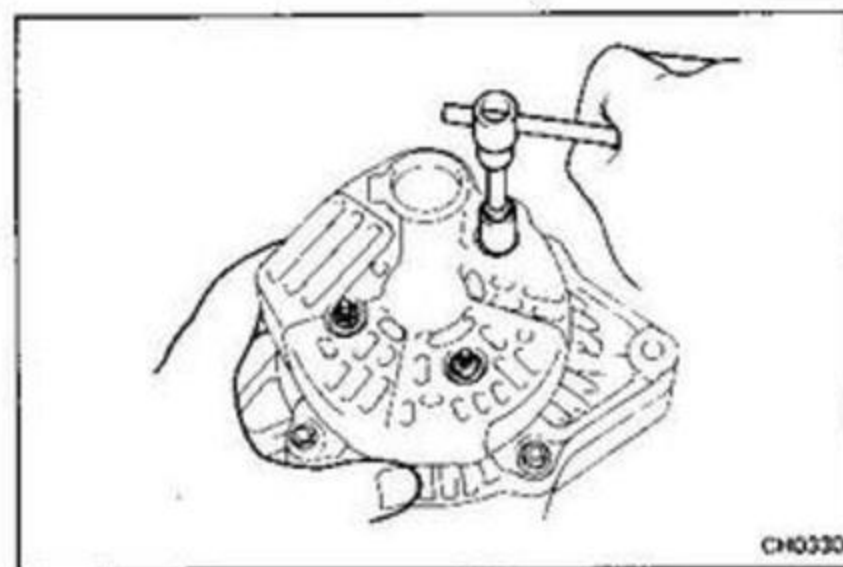

- (a) Install the end cover with the three nuts.
- (b) Install the terminal insulator with the nut.

7. CHECK THAT ROTOR ROTATES SMOOTHLY

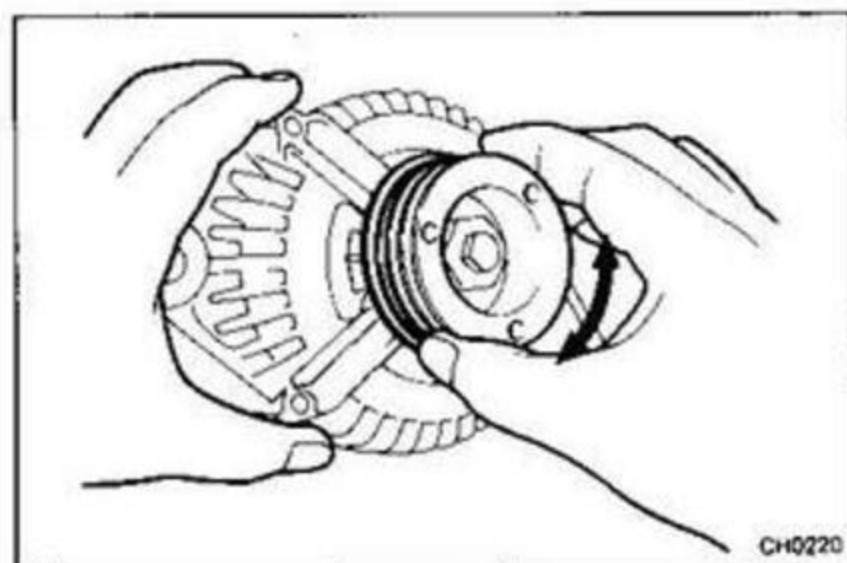

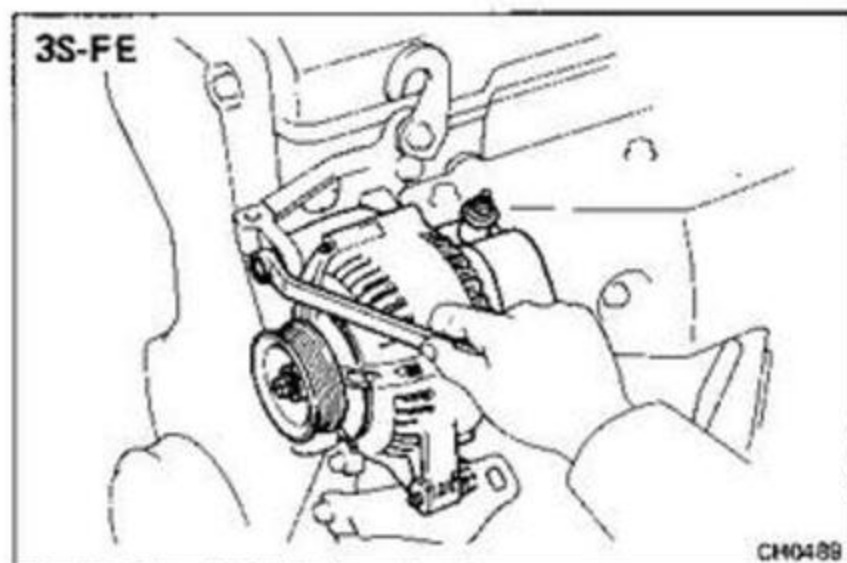

INSTALLATION OF ALTERNATOR

1. INSTALL ALTERNATOR

(3S-FE)

Mount the alternator on the alternator brackets with the pivot bolt and adjusting lock bolt. Do not tighten the bolts yet.

(3S-GE)

Mount the alternator on the alternator brackets with the two bolts.

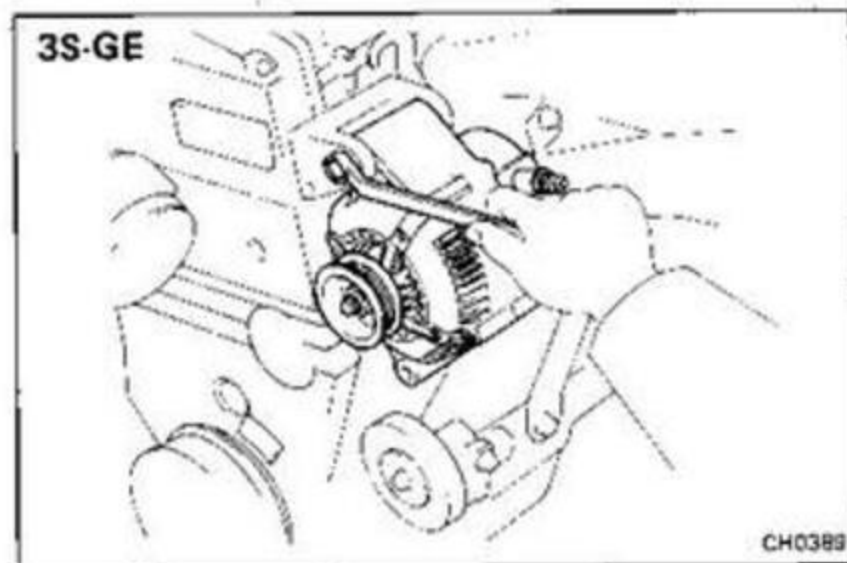

2. INSTALL DRIVE BELT

Adjust the drive belt tension.

(See step 3 on page CH-3)

Drive belt tension:

3S-FE	w/	Air con.	New belt	175 ± 5 lb
			Used belt	130 ± 10 lb
	w/o	Air con.	New belt	125 ± 25 lb
			Used belt	95 ± 20 lb
3S-GE	w/	Air con.	New belt	175 ± 5 lb
			Used belt	115 ± 20 lb
	w/o	Air con.	New belt	150 ± 25 lb
			Used belt	130 ± 25 lb

3. CONNECT CONNECTOR AND WIRE

- (a) Alternator connector
- (b) Alternator wire
- (c) (3S-GE)
A/C compressor connectors
- (d) (3S-GE)
Water temperature switch connector

4. CONNECT CABLE TO NEGATIVE TERMINAL OF BATTERY

5. PERFORM ON-VEHICLE INSPECTION

(See steps 5 to 7 on pages CH-4 to 5)

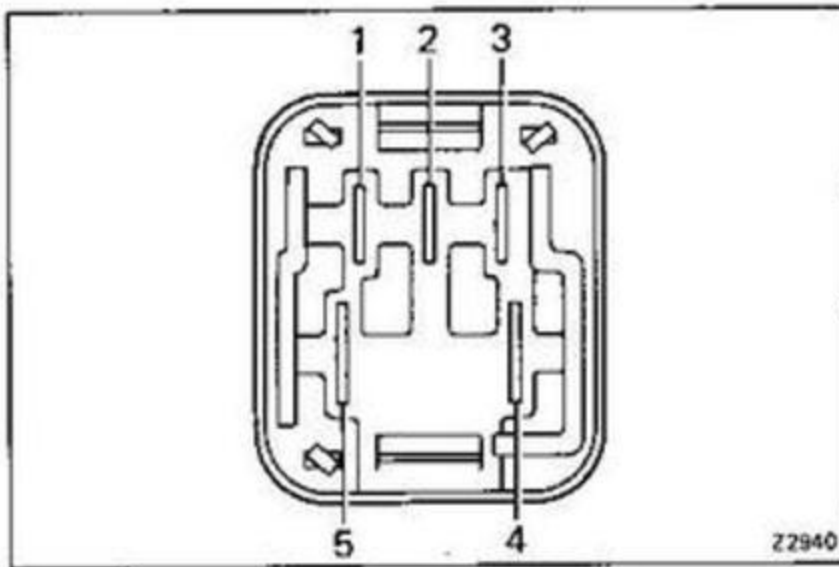

ENGINE MAIN RELAY

INSPECTION OF ENGINE MAIN RELAY

LOCATION: In the engine compartment relay box.

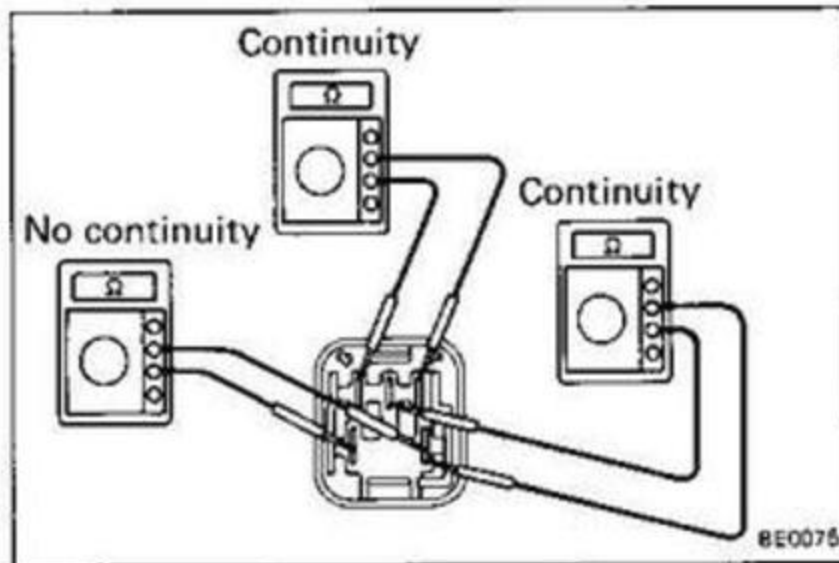

1. INSPECT RELAY CONTINUITY

- Using an ohmmeter, check that there is continuity between terminals 1 and 3.
- Check that there is continuity between terminals 2 and 4.
- Check that there is no continuity between terminals 4 and 5.

If continuity is not as specified, replace the relay.

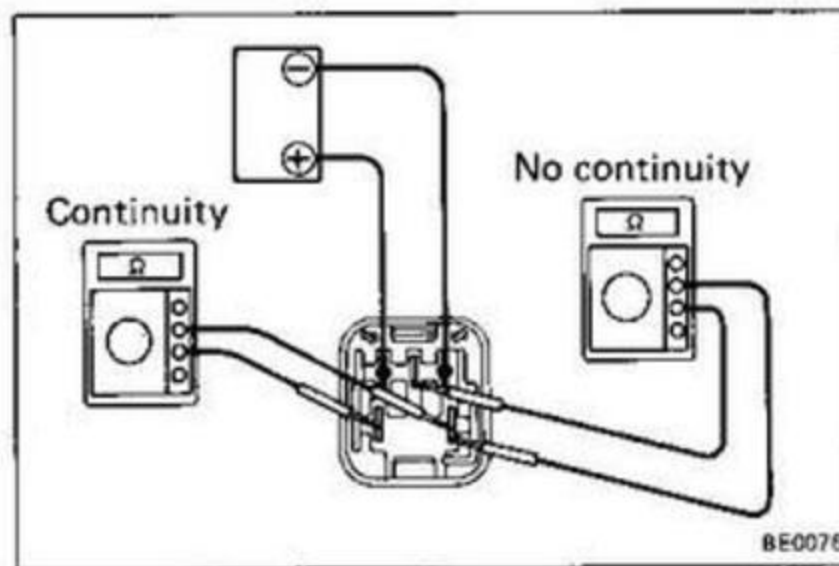

2. INSPECT RELAY OPERATION

- Apply battery voltage across terminals 1 and 3.
- Using an ohmmeter, check that there is continuity between terminals 2 and 4.
- Check that there is no continuity between terminals 4 and 5.

If operation is not as specified, replace the relay.