

COOLING SYSTEM

	Page
DESCRIPTION	CO-2
TROUBLESHOOTING	CO-5
CHECK AND REPLACEMENT OF ENGINE COOLANT	CO-6
WATER PUMP	CO-7
THERMOSTAT	CO-10
RADIATOR	CO-11
ELECTRIC COOLING FAN	CO-17

CO

DESCRIPTION

This engine utilizes a pressurized water forced circulation cooling system which includes a thermostat equipped with a bypass valve mounted on the inlet side.

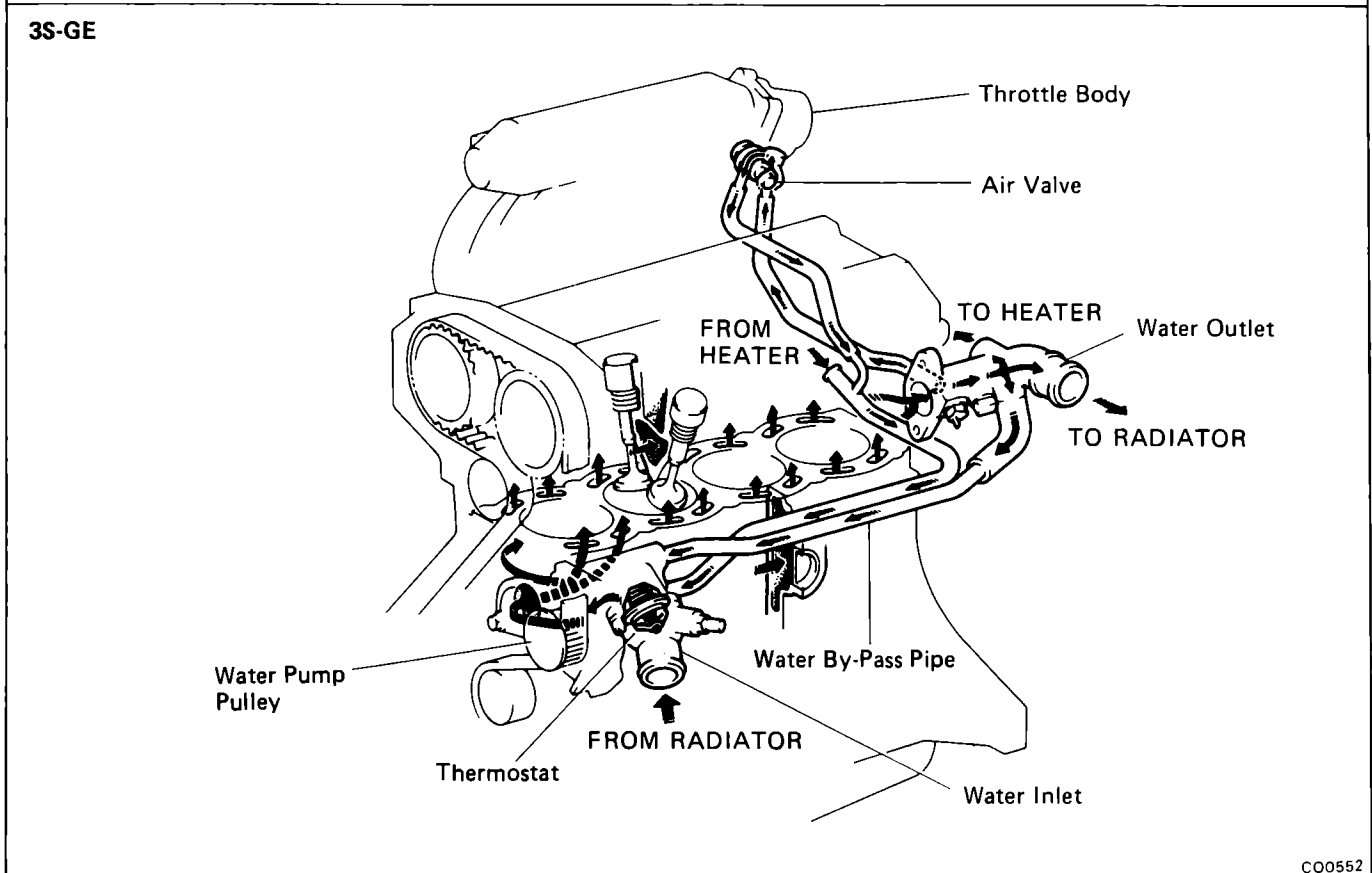
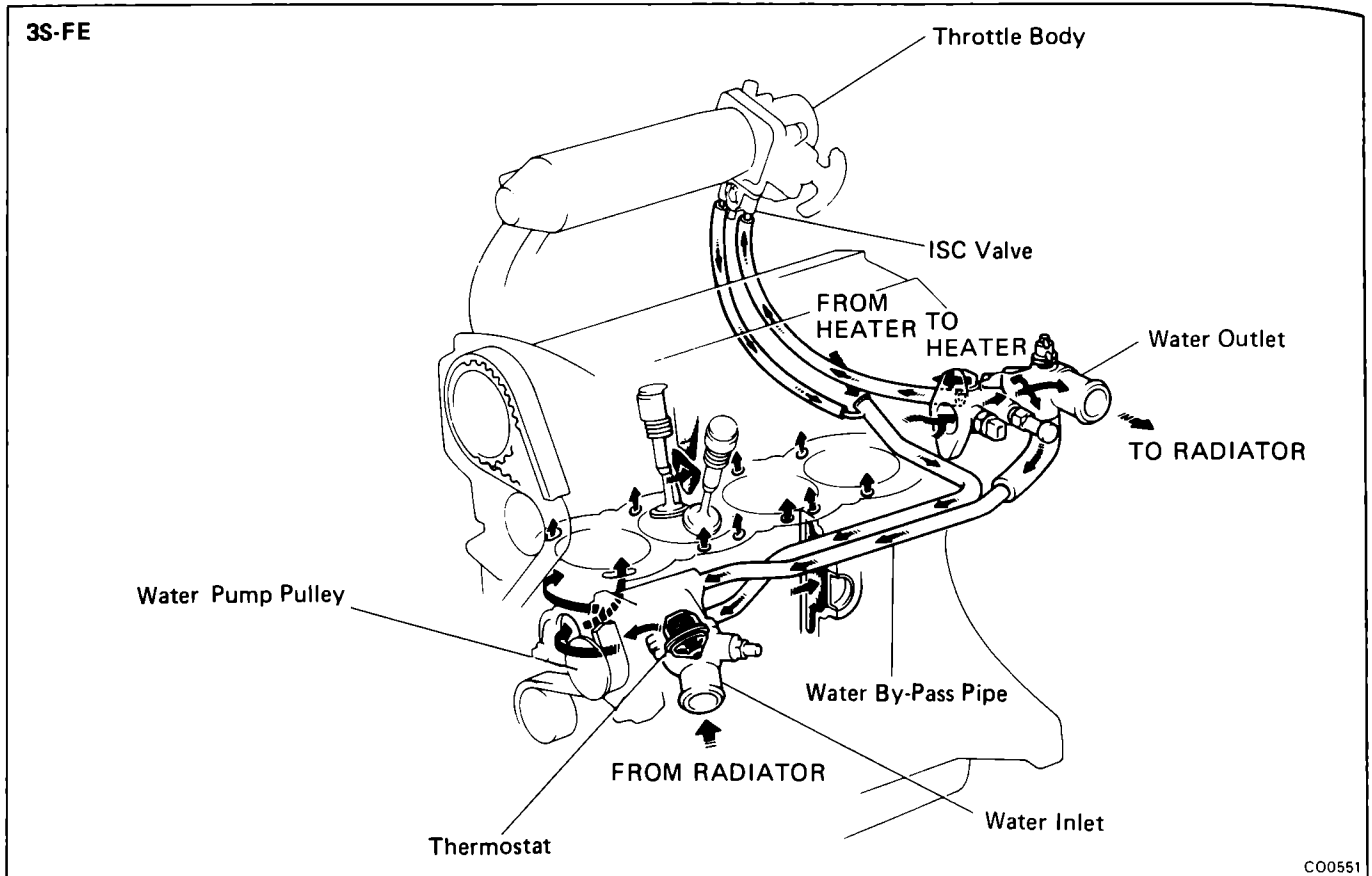

3S-GTE

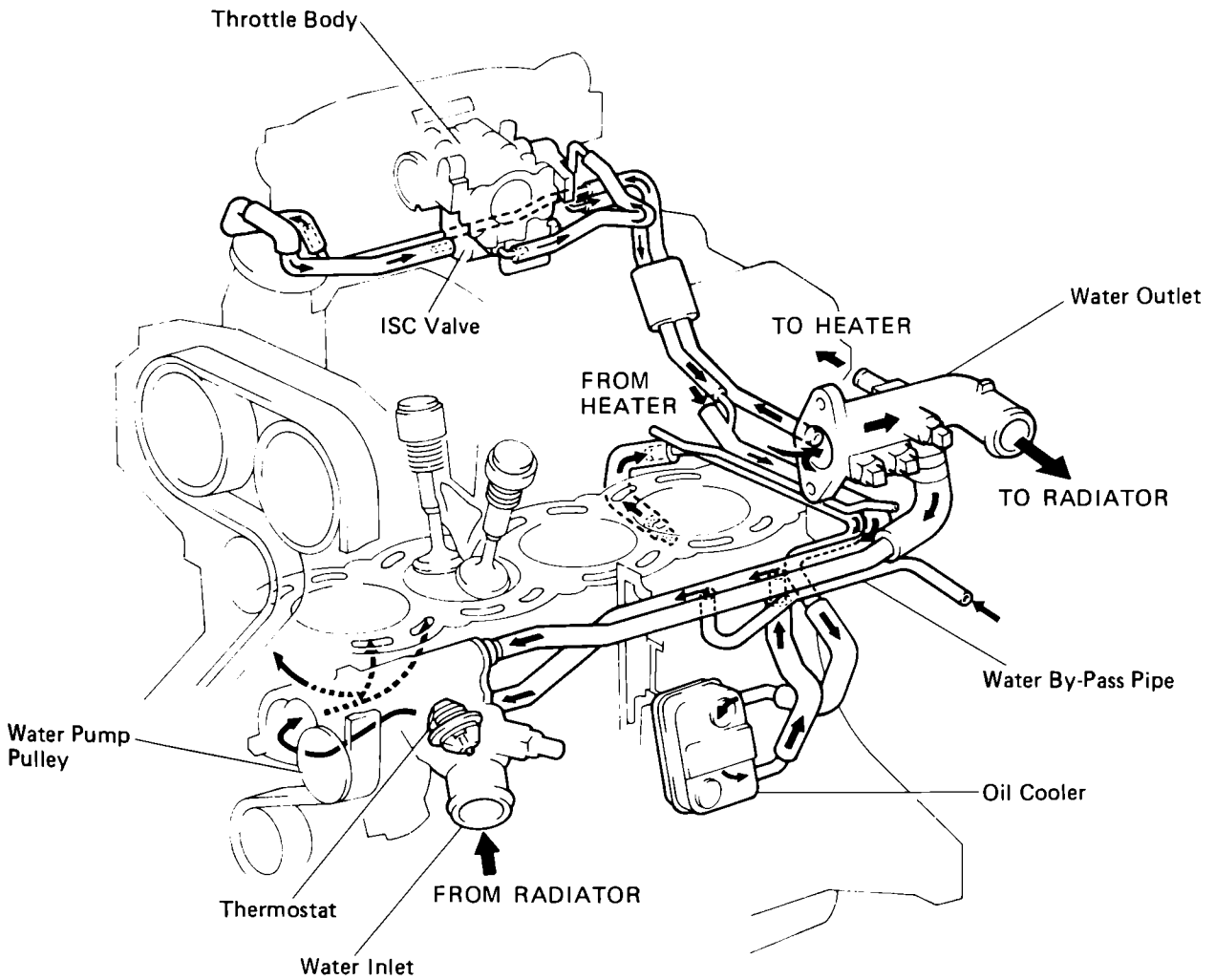

The cooling system is composed of the water jacket (inside the cylinder block and cylinder head), radiator, water pump, thermostat, electric cooling fan, hoses and other components.

Coolant which is heated in the water jacket is pumped to the radiator, through which an electric cooling fan blows air to cool the coolant as it passes through. Coolant which has been cooled is then sent back to the engine by the water pump, where it cools the engine.

The water jacket is a network of channels in the shell of the cylinder block and cylinder head through which coolant passes. It is designed to provide adequate cooling of the cylinders and combustion chambers which become the hottest during engine operation.

RADIATOR

The radiator performs the function of cooling the coolant which has passed through the water jacket and become hot, and it is mounted in the front of the vehicle. The radiator consists of an upper tank and lower tank, and a core which connects the two tanks. The upper tank contains the inlet for coolant from the water jacket and the filter inlet. It also has a hose attached through which excess coolant or steam can flow. The lower tank has an outlet and drain cock for the coolant. The core contains many tubes through which coolant flows from the upper tank to the lower tank as well as cooling fins which radiate heat away from the coolant in the tubes. The air sucked through the radiator by the electric cooling fan, as well as the wind generated by the vehicle's travel, passes through the radiator, cooling the coolant. Models with automatic transmissions include an automatic transmission fluid cooler built into the lower tank of the radiator. A fan with an electric motor is mounted behind the radiator to assist the flow of air through the radiator. The fan operates when the coolant temperature becomes high in order to prevent it from becoming too high.

RADIATOR CAP

The radiator cap is a pressure-type cap which seals the radiator, resulting in pressurization of the radiator as the coolant expands. The pressurization prevents the coolant from boiling even when the coolant temperature exceeds 100°C (212°F). A relief valve (pressurization valve) and a vacuum valve (negative pressure valve) are built into the radiator cap. The relief valve opens and lets steam escape through the overflow pipe when the pressure generated inside the cooling system exceeds the limit (coolant temperature; 110 – 120°C, 230 – 248°F, pressure; 0.3 – 1.0 kg/cm², 4.3 – 14.2 psi, 29.4 – 98.1 kPa). The vacuum valve opens to alleviate the vacuum which develops in the coolant system after the engine is stopped and the coolant temperature drops. The valve's opening allows the pressure in the cooling system to return to the reservoir tank.

RESERVOIR TANK

The reservoir tank is used to catch coolant which overflows the cooling system as a result of volumetric expansion when the coolant is heated. The coolant in the reservoir tank returns to the radiator when the coolant temperature drops, thus keeping the radiator full at all times and avoiding needless coolant loss. Check the reservoir tank level to find out if the coolant needs to be replenished.

WATER PUMP

The water pump is used for forced circulation of coolant through the cooling system. It is mounted on the front of the cylinder block and driven by a V-ribbed belt.

THERMOSTAT

The thermostat has a wax type by-pass valve and is mounted in the water inlet housing. The thermostat includes a type of automatic valve operated by fluctuations in the coolant temperature. This valve closes when the coolant temperature drops, preventing the circulation of coolant through the engine and thus permitting the engine to warm up rapidly. The valve opens when the coolant temperature has risen, allowing the circulation of coolant. Wax inside the thermostat expands when heated and contracts when cooled. Heating the wax thus generates pressure which overpowers the force of the spring which keeps the valve closed, thus opening the valve. When the wax cools, its contraction causes the force of the spring to take effect once more, closing the valve. The thermostat in this engine operates at a temperature of 82°C (180°F).

TROUBLESHOOTING

Problem	Possible cause	Remedy	Page
Engine overheats	Dirt, leaves or insects in radiator or condenser Hoses, water pump, thermostat housing, radiator, heater, core plugs or head gasket leakage	Clean radiator or condenser Repair as necessary	CO-11
	Thermostat faulty	Check thermostat	CO-10
	Incorrect ignition timing	Reset timing	IG-17, 20
	Electric cooling system faulty	Inspect electric cooling system	CO-17
	Radiator hose plugged or rotted	Replace hose	
	Water pump faulty	Replace water pump	CO-7
	Radiator plugged or cap faulty	Check radiator and cap	CO-11
	Cylinder head or block cracked or water passage clogged	Repair as necessary	

NOTE: If the engine tends to overheat, removal of the thermostat will adversely effect, cooling efficiency.

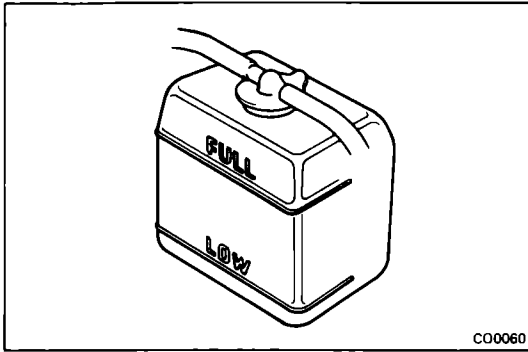

CO0060

CHECK AND REPLACEMENT OF ENGINE COOLANT

1. CHECK ENGINE COOLANT LEVEL AT RESERVE TANK

The coolant level should be between the "LOW" and "FULL" lines.

If low, check for leaks and add coolant up to the "FULL" line.

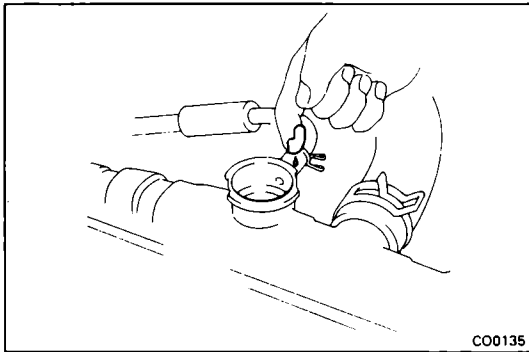

CO0135

2. CHECK ENGINE COOLANT QUALITY

There should not be any excessive deposits of rust or scales around the radiator cap or radiator filler hole, and the coolant should be free from oil.

If excessively dirty, replace the coolant.

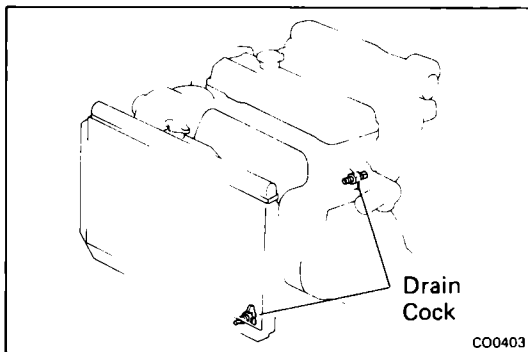

CO0403

3. REPLACE ENGINE COOLANT

- (a) Remove the radiator cap.
- (b) Drain the coolant from the radiator and engine drain cocks. (Engine drain cock at the right rear of engine block.)
- (c) Close the drain cocks.

Torque (Engine drain cock):

130 kg-cm (9 ft-lb, 13 N·m)

- (d) Fill the system with coolant.
Use a good brand of ethylene-glycol base coolant, mixed according to the manufacturer's directions.

Capacity (w/ Heater):

3S-FE	M/T	6.3 liters (6.7 US qts, 5.5 Imp. qts)
	A/T	6.2 liters (6.6 US qts, 5.5 Imp. qts)
3S-GE	M/T	6.2 liters (6.6 US qts, 5.5 Imp. qts)
	A/T	6.1 liters (6.4 US qts, 5.4 Imp. qts)
3S-GTE		6.4 liters (6.8 US qts, 5.6 Imp. qts)

- (e) Install the radiator cap.
- (f) Start the engine and check for leaks.
- (g) Recheck the coolant level and refill as necessary.

WATER PUMP COMPONENTS

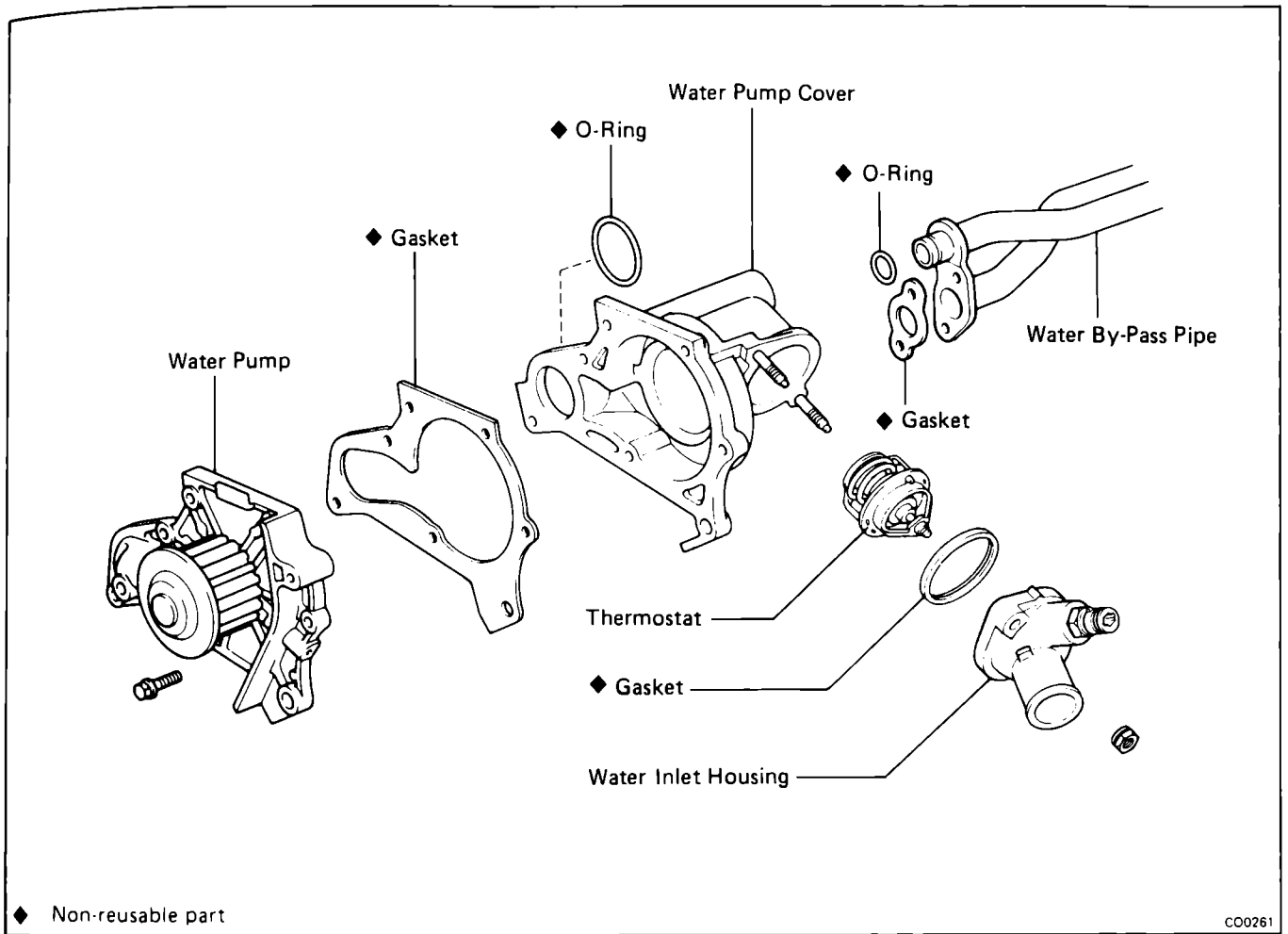

REMOVAL OF WATER PUMP

1. DRAIN ENGINE COOLANT (See page CO-6)
2. DISCONNECT WATER TEMPERATURE SWITCH CONNECTOR
3. DISCONNECT RADIATOR LOWER HOSE FROM WATER INLET HOUSING
4. REMOVE PULLEYS AND TIMING BELT
3S-FE (See pages EM-27 to 30)
3S-GE and 3S-GTE (See pages EM-38 to 41)
5. (3S-FE)
REMOVE ALTERNATOR ADJUSTING BAR
6. (3S-GE AND 3S-GTE)
REMOVE ALTERNATOR BRACKET AND IDLER PULLEY BRACKET

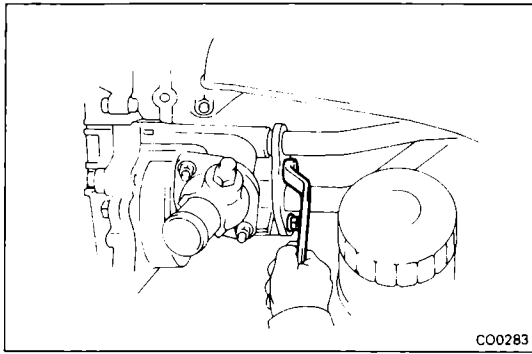

7. REMOVE WATER PUMP AND WATER PUMP COVER ASSEMBLY

- (a) Remove the two nuts holding the pump pump to the water by-pass pipe.

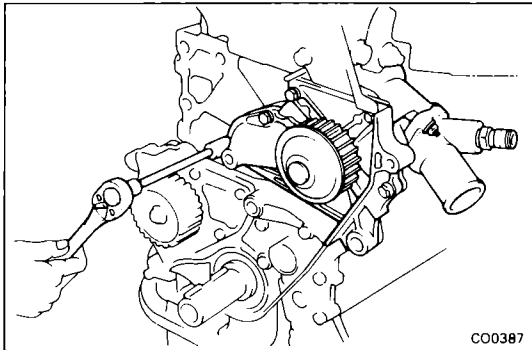

- (b) Remove the three bolts in the sequence shown.
 (c) Pull out the water pump together with pump cover.
 (d) Remove the two O-rings and gasket.

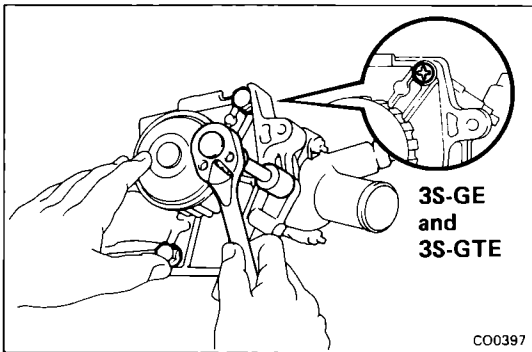

8. DISASSEMBLE WATER PUMP AND WATER PUMP COVER

Remove the three bolts, water pump and gasket from the pump cover.

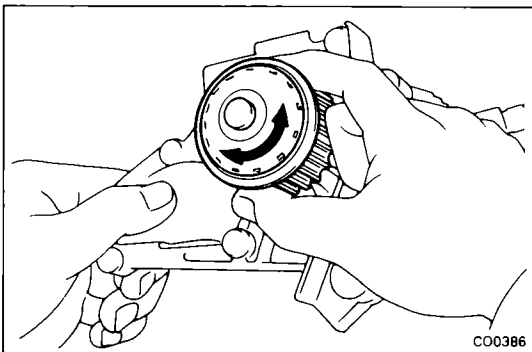

INSPECTION OF WATER PUMP

INSPECT WATER PUMP

Turn the pulley and check that the water pump bearing moves smoothly and quietly.

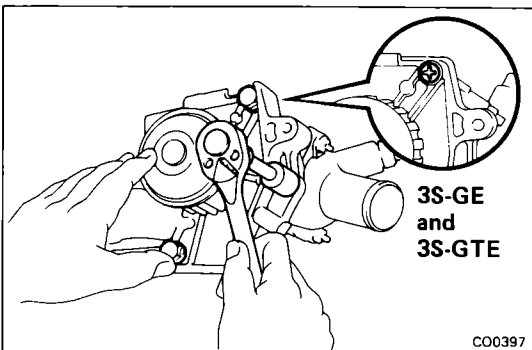

INSTALLATION OF WATER PUMP

(See page CO-7)

1. ASSEMBLE WATER PUMP AND WATER PUMP COVER

Install a new gasket and the pump to the pump cover with the three bolts.

Torque: 90 kg-cm (78 in.-lb, 8.8 N·m)

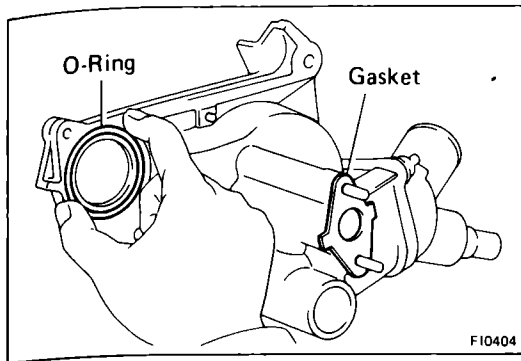

2. INSTALL WATER PUMP AND WATER PUMP COVER ASSEMBLY

(a) Install new two O-rings and gasket to the pump cover and water by-pass pipe.

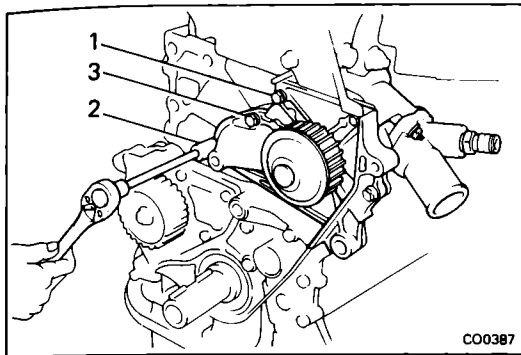

(b) Apply a light coat of engine oil on the O- ring of the water by-pass pipe.

(c) Connect the pump cover to the water by-pass pipe. Do not install the nuts yet.

(d) Install the water pump with the three bolts. Torque the bolts in the sequence shown.

Torque: 95 kg-cm (82 in.-lb, 9.3 N·m)

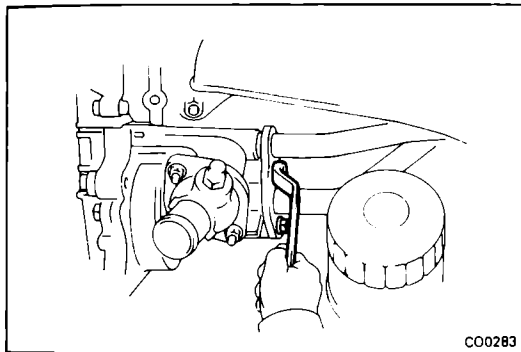

(e) Install the two nuts holding the pump cover to the water by-pass pipe.

Torque: 95 kg-cm (82 in.-lb, 9.3 N·m)

3. (3S-FE)

INSTALL ALTERNATOR ADJUSTING BAR

4. (3S-GE AND 3S-GTE)

INSTALL ALTERNATOR BRACKET AND IDLER PULLEY BRACKET

5. INSTALL PULLEYS AND TIMING BELT

3S-FE (See pages EM-33 to 37)

3S-GE and 3S-GTE (See pages EM-44 to 53)

6. CONNECT RADIATOR LOWER HOSE

7. CONNECT WATER TEMPERATURE SWITCH CONNECTOR

8. FILL WITH ENGINE COOLANT (See page CO-6)

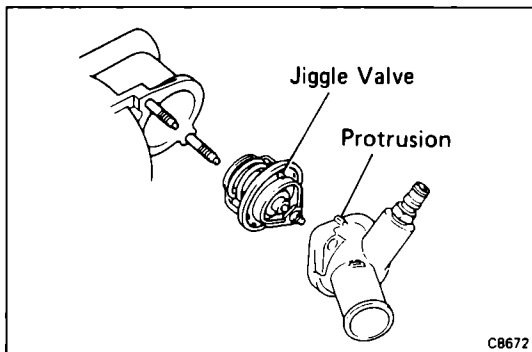
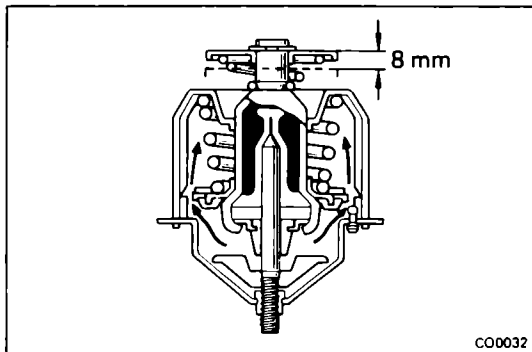
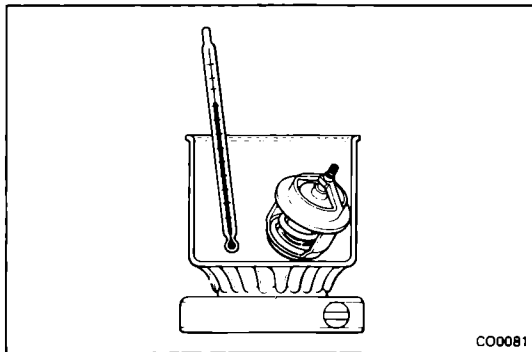
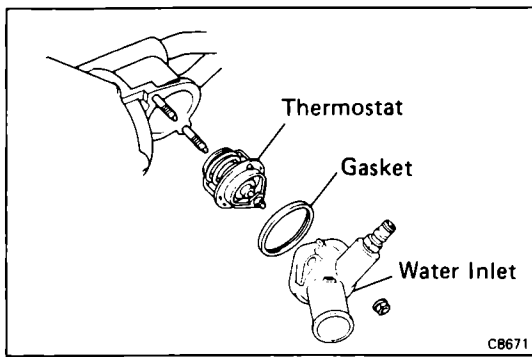

THERMOSTAT

REMOVAL OF THERMOSTAT

1. DRAIN ENGINE COOLANT (See page CO-6)
2. DISCONNECT WATER TEMPERATURE SWITCH CONNECTOR
3. DISCONNECT RADIATOR FROM WATER INLET
4. REMOVE WATER INLET
Remove the two nuts and water inlet from the water pump.
5. REMOVE THERMOSTAT AND GASKET

INSPECTION OF THERMOSTAT

INSPECT THERMOSTAT

NOTE: The thermostat is numbered with the valve opening temperature.

- (a) Immerse the thermostat in water and gradually heat the water.
- (b) Check the valve opening temperature.

Valve opening temperature:
80 – 84°C (176 – 183°F)

If the valve opening temperature is not as specified, replace the thermostat.

- (c) Check the valve lift.

Valve lift:
8 mm (0.31 in.) or more at 95°C (203°F)

If the valve lift is less than specification, replace the thermostat.

INSTALLATION OF THERMOSTAT

1. PLACE THERMOSTAT IN WATER INLET
 - (a) Install a new gasket to the thermostat.
 - (b) Align the jiggle valve of the thermostat with protrusion of the water inlet and, insert the thermostat in the water inlet.
2. INSTALL WATER INLET AND THERMOSTAT ASSEMBLY
Install the water inlet and thermostat assembly with the two nuts.
Torque: 90 kg-cm (78 in.-lb, 8.8 N·m)
3. CONNECT RADIATOR LOWER HOSE
4. CONNECT WATER TEMPERATURE SWITCH CONNECTOR
5. FILL WITH ENGINE COOLANT (See page CO-6)
6. START ENGINE AND CHECK FOR LEAKS

RADIATOR COMPONENTS

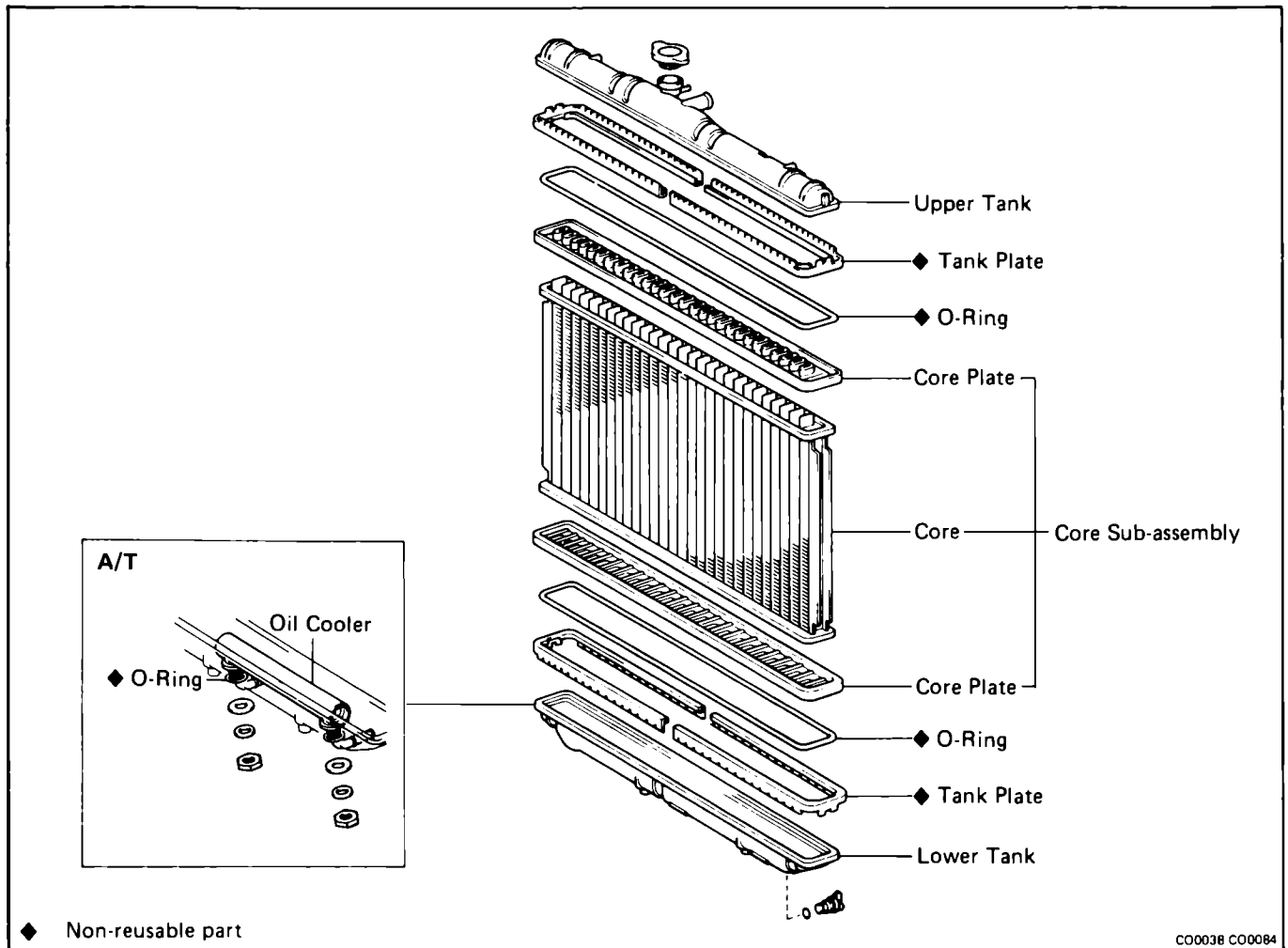

CLEANING OF RADIATOR

Using water or a steam cleaner, remove any mud and dirt from the radiator core.

CAUTION: If using a high pressure type cleaner, be careful not to deform the fins of the radiator core. If the cleaner nozzle pressure is 30 – 35 kg/cm² (427 – 498 psi, 2,942 – 3,432), keep a distance of at least 40 – 50 cm (15.75 – 19.69 in.) between the radiator core and cleaner nozzle.

INSPECTION OF RADIATOR

1. INSPECT RADIATOR CAP

Using a radiator cap tester, pump the tester and measure the relief valve opening pressure.

Standard opening pressure:

0.75 – 1.05 kg/cm²
(10.7 – 14.9 psi, 74 – 103 kPa)

Minimum opening pressure:

0.6 kg/cm² (8.5 psi, 59 kPa)

If the opening pressure is less than minimum, replace the radiator cap.

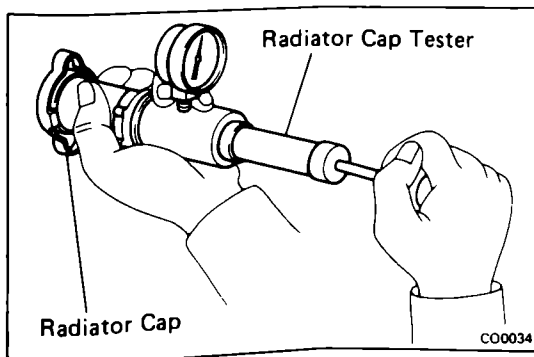

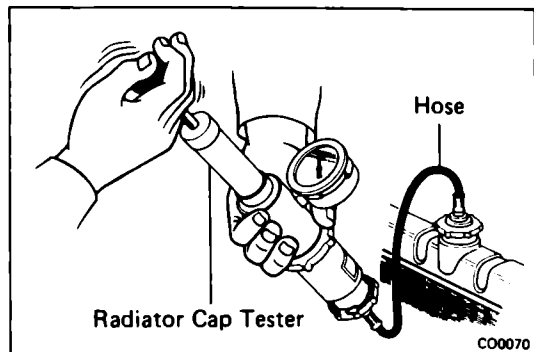

2. INSPECT COOLING SYSTEM FOR LEAKS

- (a) Fill the radiator with coolant and attach a radiator cap tester.
- (b) Warm up the engine.
- (c) Pump it to 1.2 kg/cm² (17.1 psi, 118 kPa), check that pressure does not drop.

If the pressure drops, check for leaks the hoses, radiator or water pump. If no external leaks are found, check the heater core, cylinder block and head.

REMOVAL OF RADIATOR

1. DRAIN ENGINE COOLANT (See page CO-6)
2. DISCONNECT COOLANT RESERVOIR HOSE
3. DISCONNECT RADIATOR HOSES
4. DISCONNECT COOLING FAN MOTOR CONNECTORS
5. REMOVE ENGINE ELECTRIC COOLING FAN ASSEMBLY
6. (w/ A/C)
REMOVE AIR CONDITIONER (A/C) ELECTRIC COOLING FAN ASSEMBLY
7. (A/T)
DISCONNECT OIL COOLER HOSES
8. REMOVE RADIATOR
Remove the two bolts, supports and radiator.

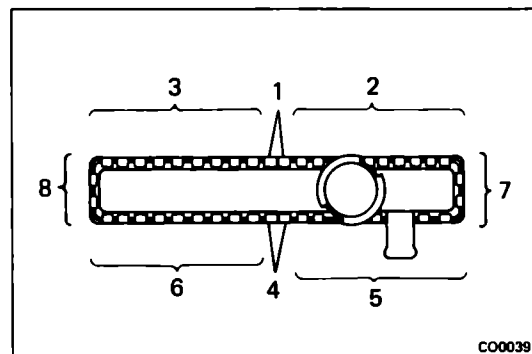
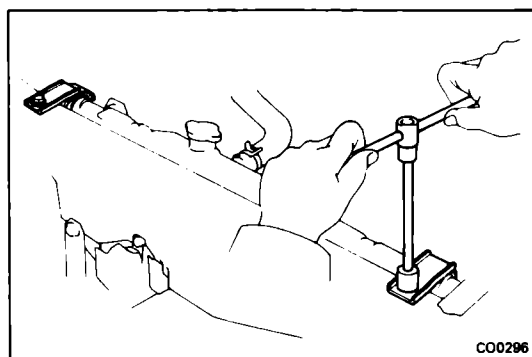

DISASSEMBLY OF RADIATOR

(See page CO-11)

1. REMOVE TANK PLATE
 - (a) Raise the claws of the tank plates with SST in the numerical order shown in the figure.

SST 09230-00010

CAUTION: Be careful not to damage the core plate.

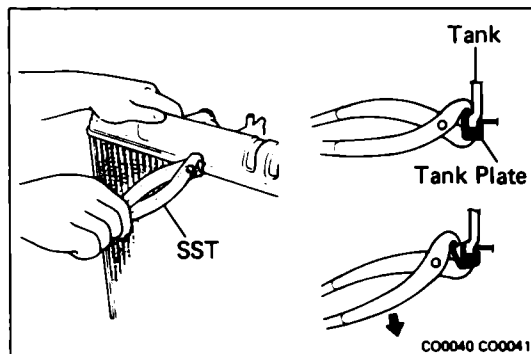

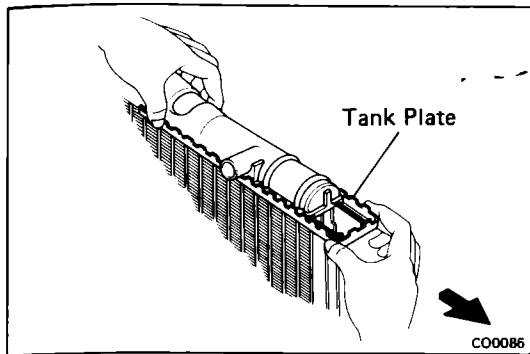

(b) Pull the tank plates outward.

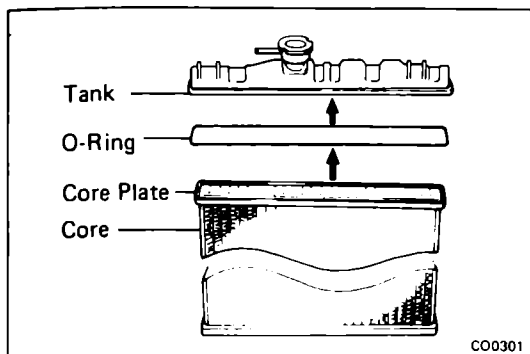

2. REMOVE TANK

- (a) Pull the tank upward.
- (b) Remove the O-ring.

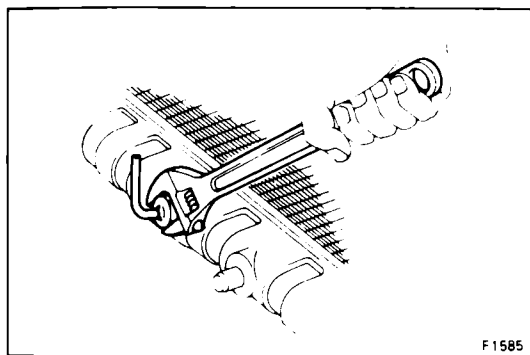

3. (A/T) REMOVE OIL COOLER FROM LOWER TANK

Remove the two nuts, spring washers, plate washers, oil cooler and two O-rings.

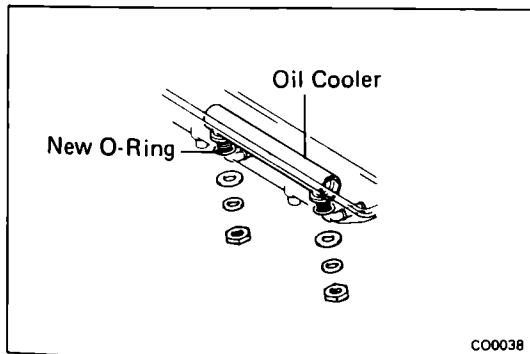

ASSEMBLY OF RADIATOR

(See page CO-11)

1. (A/T) INSTALL OIL COOLER TO LOWER TANK

- (a) Install new two O-rings to the oil cooler.
- (b) Install the oil cooler with the two plate washers, spring washers and nuts.

Torque: 220 kg-cm (16 ft-lb, 22 N·m)

2. CHECK CORE PLATE FOR DAMAGE

NOTE:

- If the sides of the core plate groove are deformed, reassembly of the tank will be impossible. Therefore, first correct any deformation with pliers.
- Water leakage will result if the bottom of the core plate groove is damaged or dented. Therefore, repair or replace if necessary.

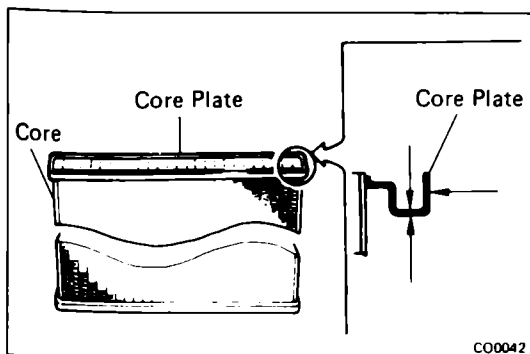

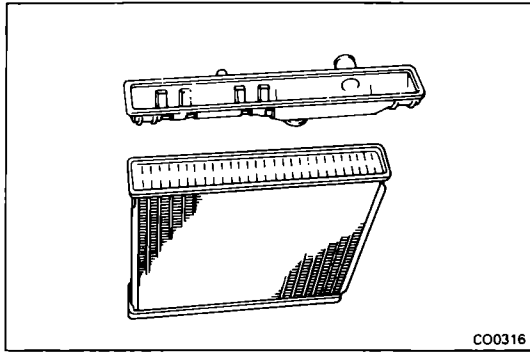

3. INSTALL TANK

Install a new O-ring and the tank.

NOTE:

- Clean the tank and core plate.

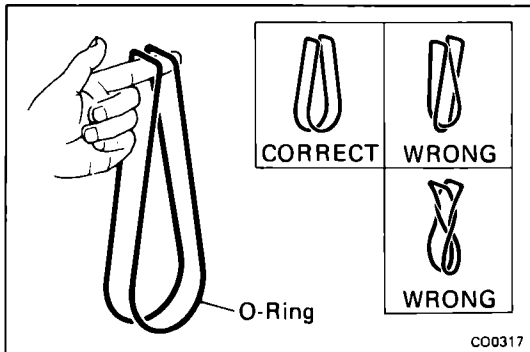

- Take out any twists.

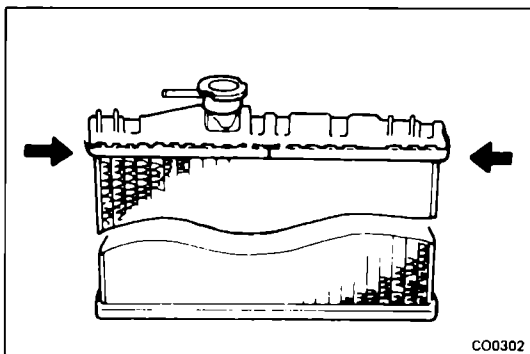

4. INSTALL TANK PLATE

Insert new tank plates from both ends in the direction of the arrows. Firmly set the tank plates in the core plate.

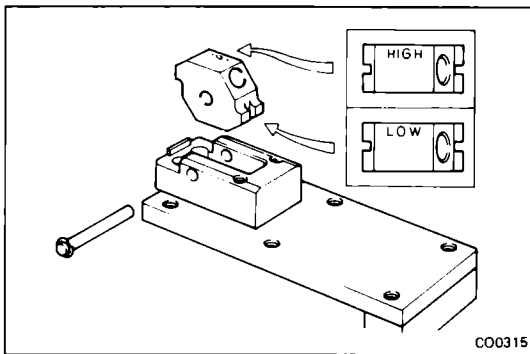

5. STAKE CLAWS OF TANK PLATES

(a) Set the punch of SST to "LOW".

SST 09230-00010

(b) Stake the claws of the tank plates with SST in the numerical order shown in the figure.

SST 09230-00010

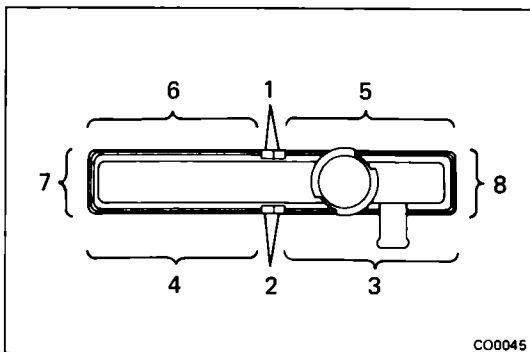

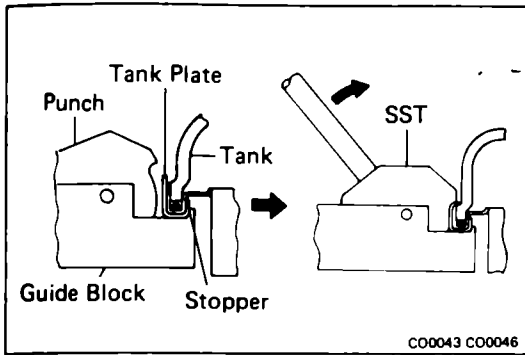

CAUTION: If the bottom of the core plate is staked with the SST on the guide block stopper, it may result in water leakage.

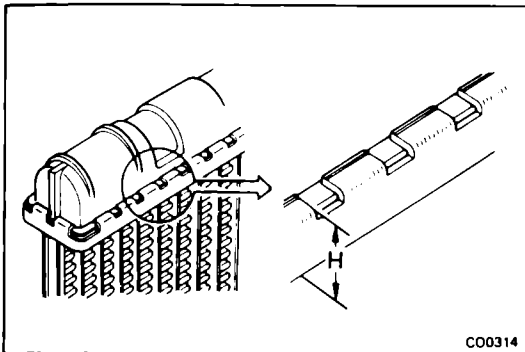

NOTE:

- Stake with just enough pressure to leave a mark on the claw. The staked plate height (H) should be as follows:

Plate height (H): 9.0 – 9.4 mm (0.354 – 0.370 in.)

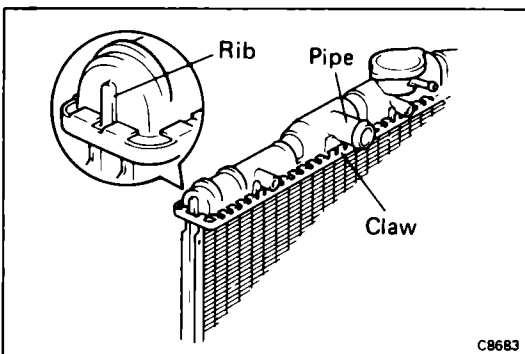

- Do not stake the areas protruding around the pipes, brackets or tank ribs.

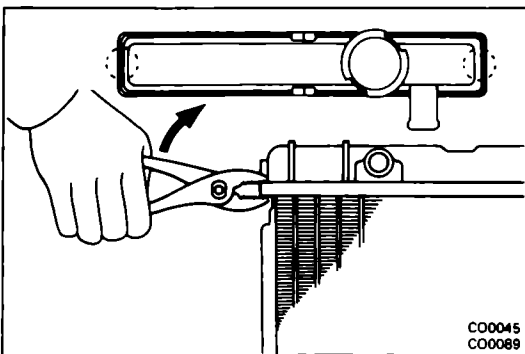

- The points shown in the illustration cannot be staked with the SST. Use pliers or a like object and be careful not to damage the core plates.

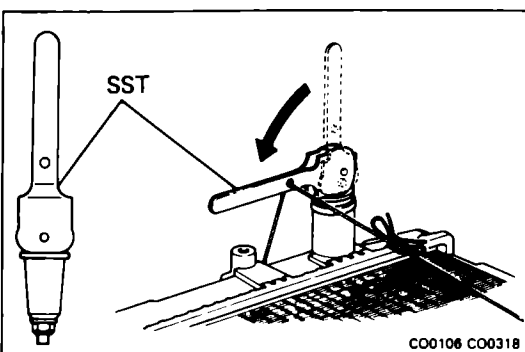

6. CHECK FOR WATER LEAKS

- Tighten the drain plug.
- Plug the inlet and outlet pipes of the radiator with SST. SST 09230-00010
- Using a radiator cap tester, apply pressure to the radiator.

Test pressure: 1.8 kg/cm² (26 psi, 177 kPa)

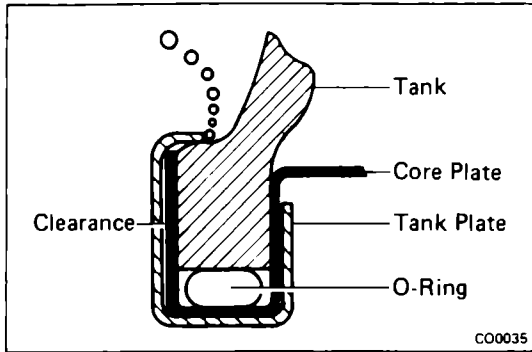

(d) Check for water leaks.

NOTE: On radiators with resin tanks, there is a clearance between the core plate and tank plate where a minute amount of air will remain, giving the appearance of an air leak when the radiator is submerged in water. therefore, before performing the water leak test, first swish the radiator around in the water until all air bubbles disappear.

7. PAINT TANK PLATE

NOTE: If the water leak test checks out okay, allow the radiator to completely dry and then paint the tank plate.

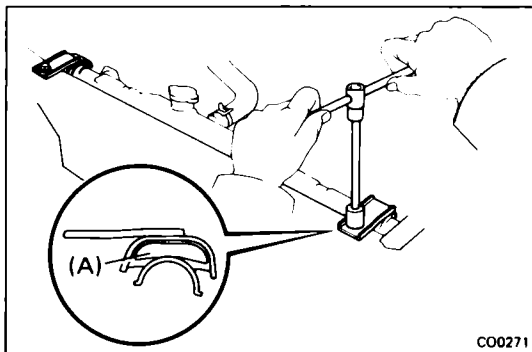

INSTALLATION OF RADIATOR

1. INSTALL RADIATOR

Place the radiator in position, and install the two supports with the two bolts.

NOTE: After installation, check that the rubber cushion (A) of the supports are not depressed.

2. (A/T)

CONNECT OIL COOLER HOSES

3. INSTALL ENGINE ELECTRIC COOLING FAN ASSEMBLY

4. (w/ A/C)

INSTALL AIR CONDITIONER (A/C) ELECTRIC COOLING FAN ASSEMBLY

5. CONNECT COOLING FAN MOTOR CONNECTORS

6. CONNECT RADIATOR HOSES

7. CONNECT COOLANT RESERVOIR HOSE

8. FILL WITH ENGINE COOLANT (See step 3 on page CO-6)

9. START ENGINE AND CHECK FOR LEAKS

10. (A/T)

CHECK AUTOMATIC TRANSMISSION FLUID LEVEL

CAUTION: Do not overfill.

ELECTRIC COOLING FAN

COMPONENTS

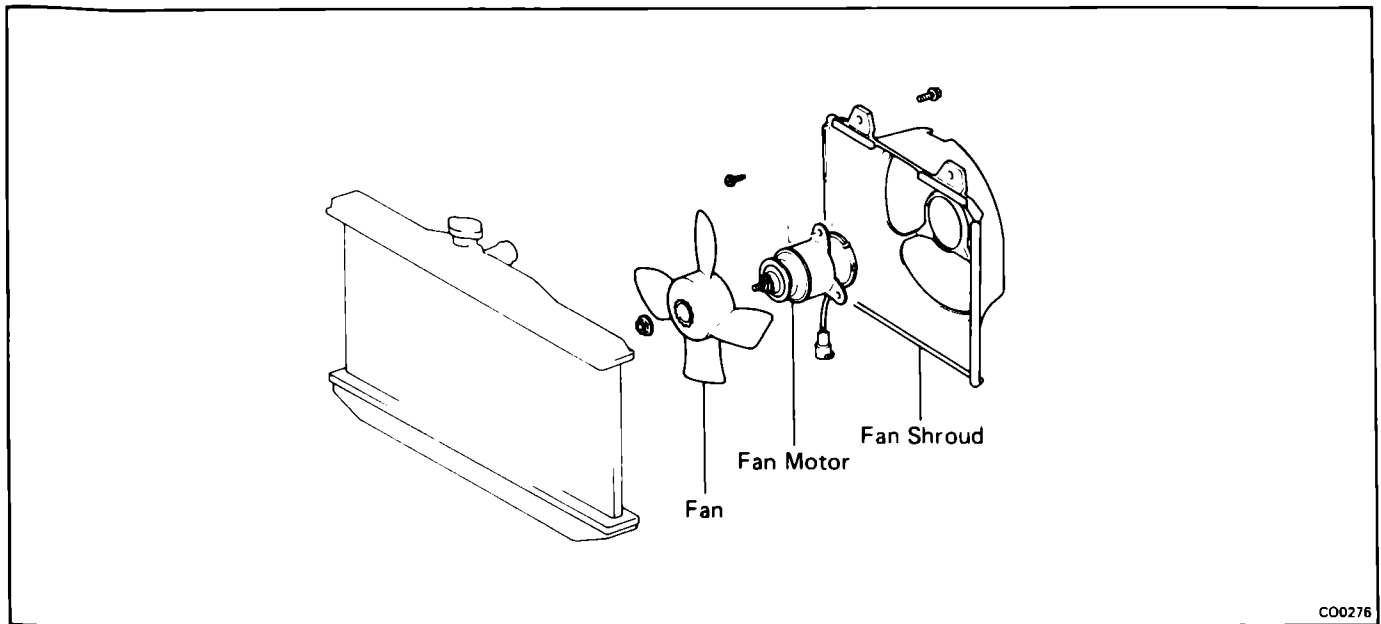

CO0276

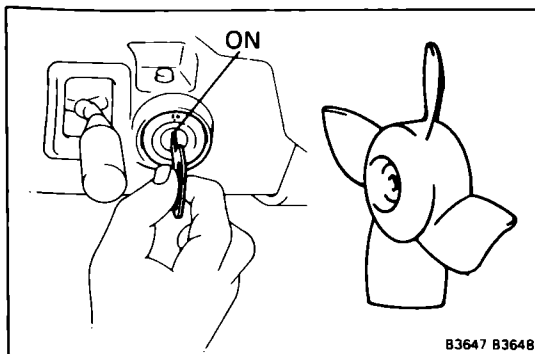

B3647 B3648

ON-VEHICLE INSPECTION

Low Temperature (Below 83°C (181°F))

1. TURN IGNITION SWITCH "ON"

Check that the fan stops.

If not, check the cooling fan relay and water temperature switch, and check for a separated connector or severed wire between the cooling fan relay and water temperature switch.

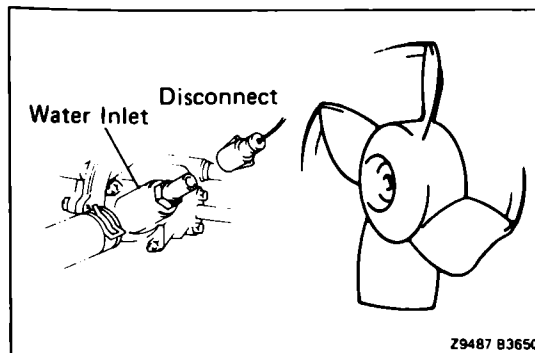

Z9487 B3650

2. DISCONNECT WATER TEMPERATURE SWITCH CONNECTOR

Check that fan rotates.

If not, check the cooling fan relay, fan motor, engine main relay and fuse, and check for a short circuit between the cooling fan relay and water temperature switch.

3. CONNECT WATER TEMPERATURE SWITCH CONNECTOR

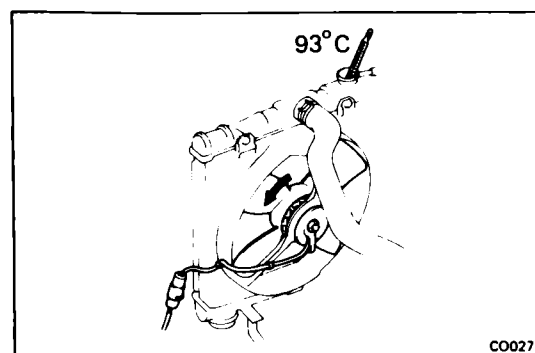

CO0272

High Temperature (Above 93°C (199°F))

4. START ENGINE

(a) Raise coolant temperature to above 93°C (199°F).

(b) Check that the fan rotates.

If not, replace the water temperature switch.

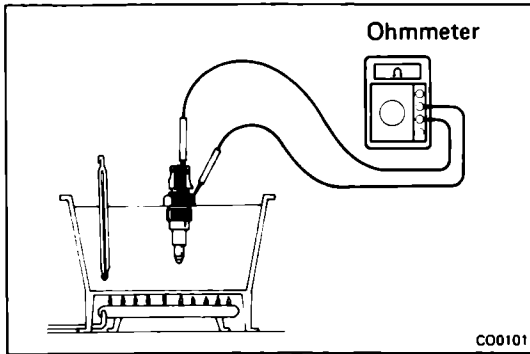

INSPECTION OF ELECTRIC COOLING FAN COMPONENTS

1. INSPECT WATER TEMPERATURE SWITCH

LOCATION: On the water inlet housing.

- (a) Using an ohmmeter, check that there is no continuity between the terminal and body when the coolant temperature is above 93°C (199°F).
- (b) Check that there is continuity between the terminal and body when the coolant temperature is below 83°C (181°F).

If continuity is not as specified, replace the switch.

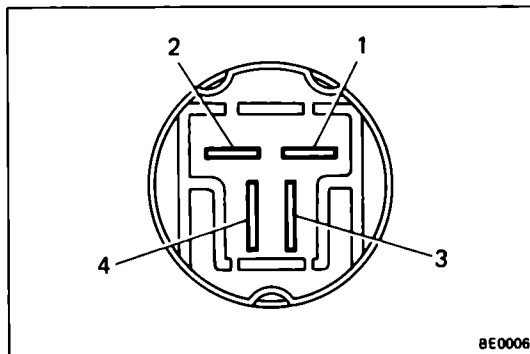

2. INSPECT COOLING FAN RELAY ("FAN NO1")

LOCATION: In the engine compartment relay box.

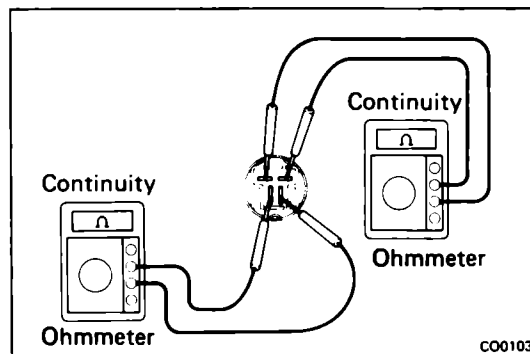

A. Inspect relay continuity

- (a) Using an ohmmeter, check that there is continuity between terminals 1 and 2.
- (b) Check that there is continuity between terminals 3 and 4.

If continuity is not as specified, replace the relay.

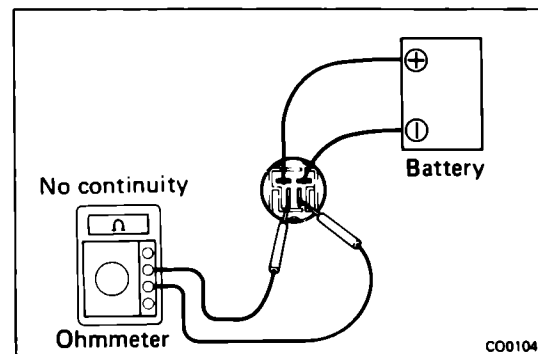

B. Inspect relay operation

- (a) Apply battery voltage across terminal 1 and 2.
- (b) Using an ohmmeter, check that there is no continuity between terminals 3 and 4.

If operation is not as specified, replace the relay.

3. INSPECT ENGINE MAIN RELAY (See page CH-16)

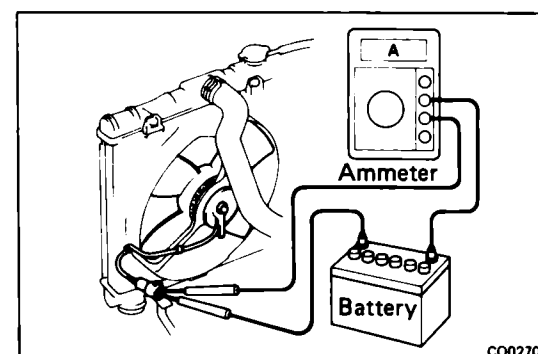

4. INSPECT COOLING FAN MOTOR

- (a) Connect battery and ammeter to the fan motor connector.
- (b) Check that the fan motor rotates smoothly, and check the reading on the ammeter.

Standard amperage:

3.2 – 4.4 A	3S-FE and 3S-GE (M/T)
5.8 – 7.4 A	3S-FE and 3S-GE (A/T)
8.6 – 11.6 A	3S-GTE