

STARTING SYSTEM

	Page
TROUBLESHOOTING	ST-2
STARTER	ST-3
STARTER RELAY (M/T only)	ST-18
CLUTCH STARTER SWITCH (M/T only)	ST-18

ST

TROUBLESHOOTING

Problem	Possible cause	Remedy	Page
Engine will not crank	Battery charge low	Check battery specific gravity	CH-3
	Battery cables loose, corroded or worn	Check or replace battery	
	Clutch start switch faulty (M/T)	Repair or replace cables	CL-4
	Neutral start switch faulty (A/T)	Adjust or replace clutch start switch	
	Starter relay faulty (M/T)	Adjust or repair switch	
	Fusible link blown	Replace starter relay	
	Starter faulty	Replace fusible link	ST-3
Engine cranks slowly	Ignition switch faulty	Repair starter	ST-3
	Battery charge low	Check battery specific gravity	CH-3
	Battery cables loose, corroded or worn	Charge or replace battery	
Starter keeps running	Starter faulty	Repair starter	ST-3
	Ignition switch faulty	Replace ignition switch	
	Short in wiring	Repair wiring	
Starter spins — engine will not crank	Starter faulty	Repair starter	ST-3
	Pinion gear teeth broken or starter faulty	Replace flywheel	
	Flywheel teeth broken		

STARTER

COMPONENTS (3S-FE and 3S-GTE)

1.0 kW Type

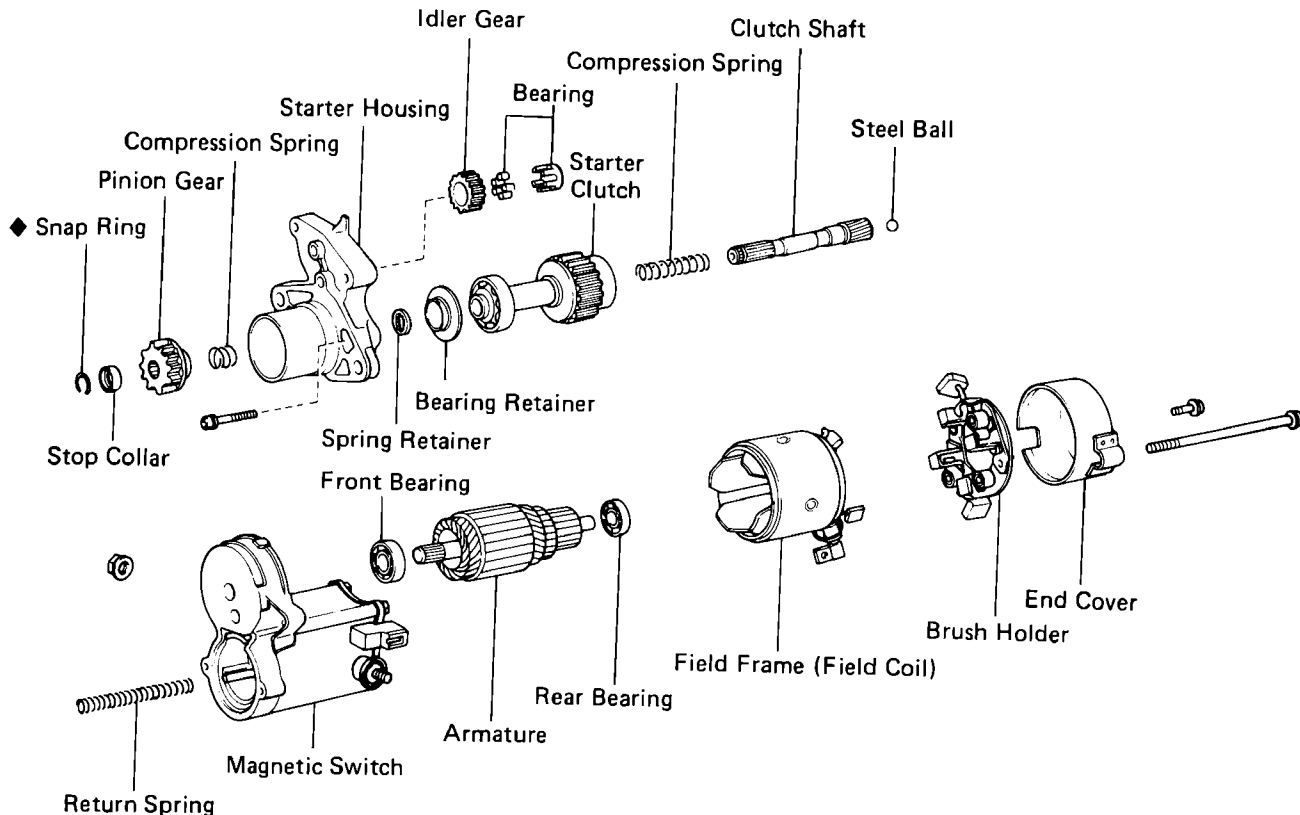

1.4 kW Type

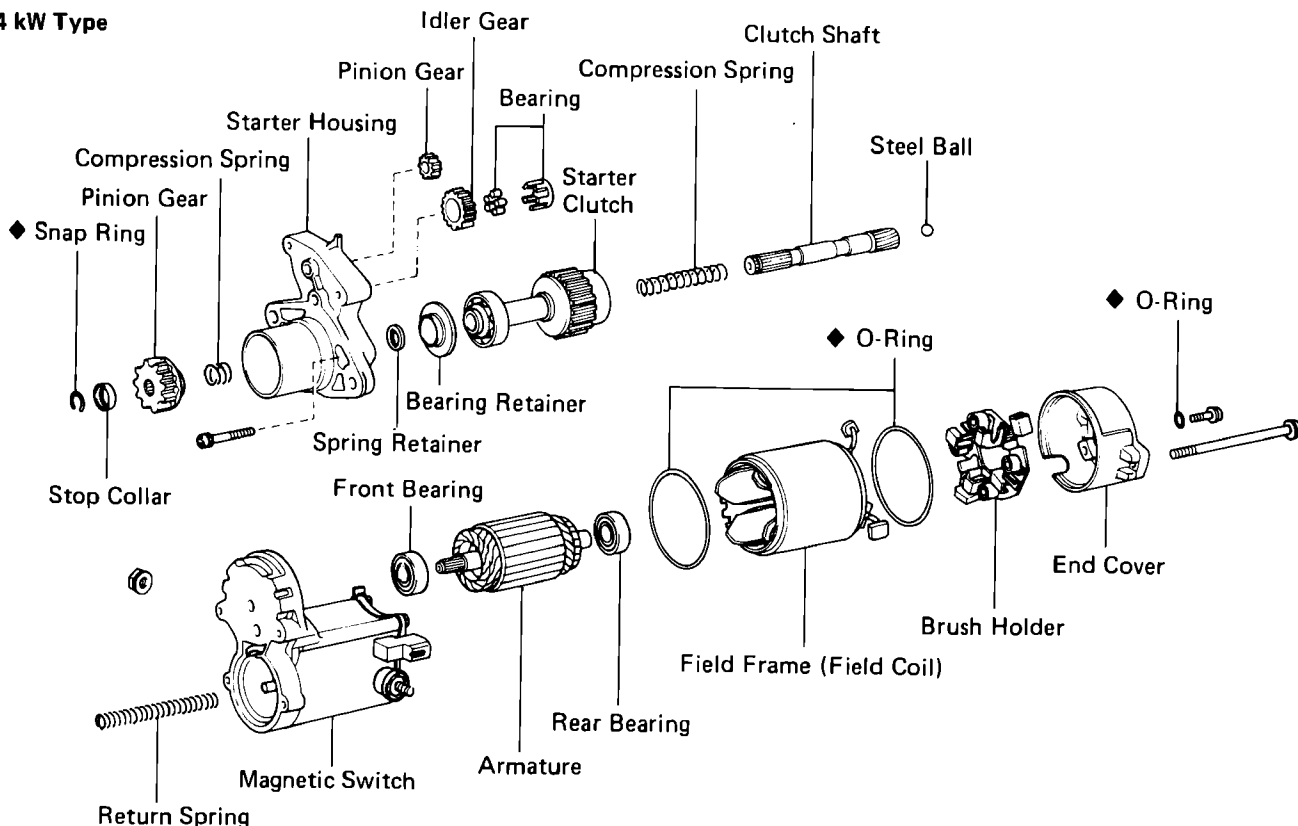

◆ Non-reusable part

COMPONENTS (3S-GE)

1.0 kW Type

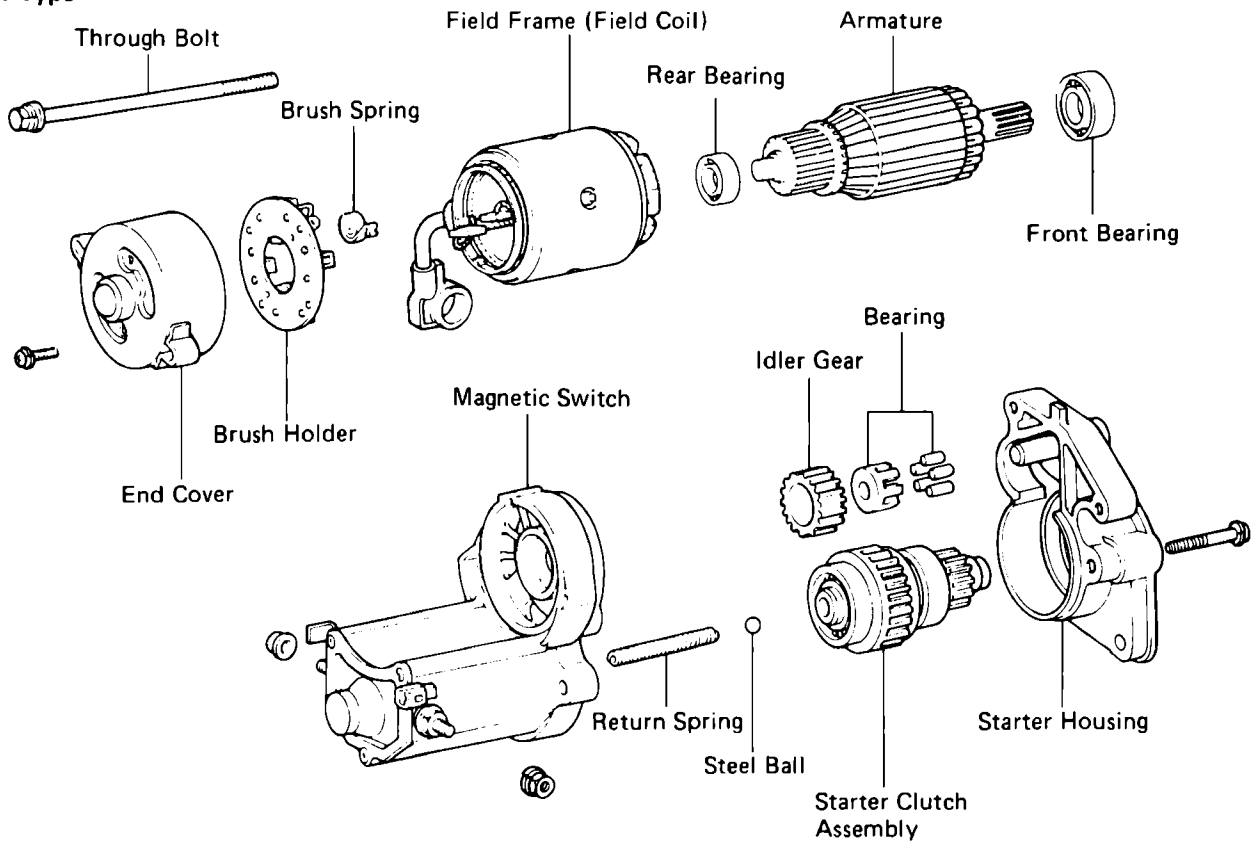

1.4 kW Type

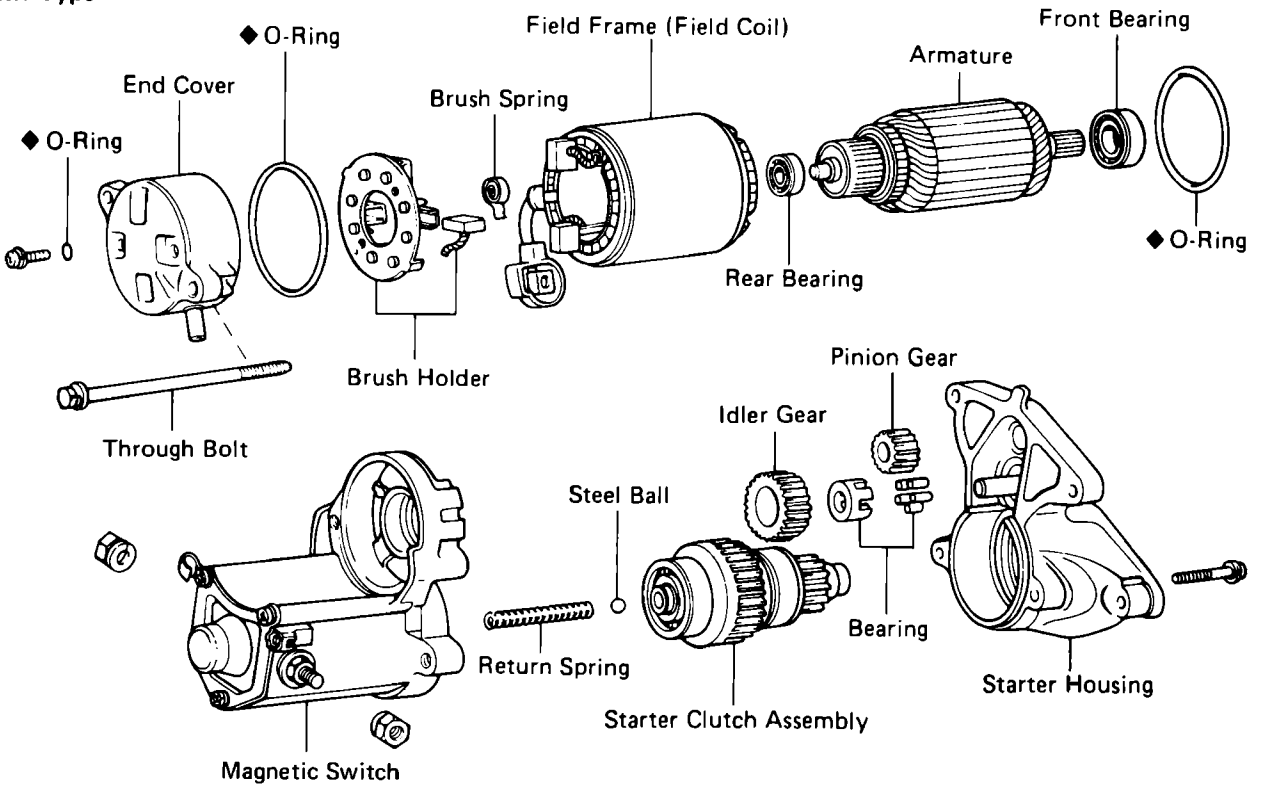

◆ Non-reusable part

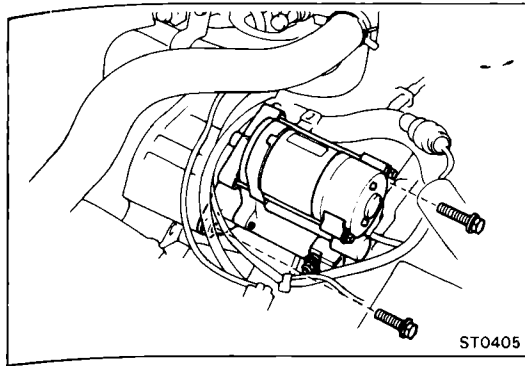

REMOVAL OF STARTER (3S-FE and 3S-GTE)

1. REMOVE BATTERY
2. (3S-GTE)
REMOVE AIR CLEANER ASSEMBLY
(See step 11 page EM-124)
3. DISCONNECT CONNECTOR AND WIRE FROM STARTER
4. REMOVE STARTER
Remove the two bolts and starter.

REMOVAL OF STARTER (3S-GE)

1. DISCONNECT CABLE FROM NEGATIVE TERMINAL OF BATTERY
2. DISCONNECT CONNECTOR AND CABLE
 - (a) Disconnect the cable from the positive (+) terminal of the battery.
 - (b) Disconnect the starter connector located on the transaxle.
3. DISCONNECT EXHAUST FRONT PIPE FROM EXHAUST MANIFOLD
(See step 28 on page EM-106)
4. REMOVE STARTER
 - (a) Remove the two bolts and starter.
 - (b) Remove the starter cover.
 - (c) Remove the starter cable.

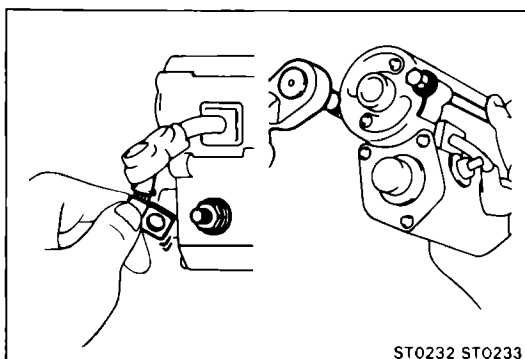
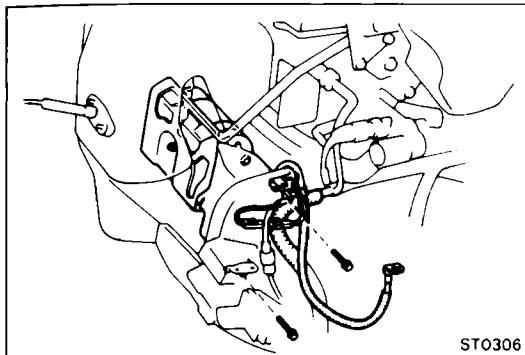

DISASSEMBLY OF STARTER

3S-FE and 3S-GTE (See page ST-3)

3S-GE (See page ST-4)

1. REMOVE FIELD FRAME AND ARMATURE
 - (a) Remove the nut, and disconnect the lead wire from the magnetic switch terminal.
 - (b) Remove the two through bolts, and pull out the field frame together with the armature.
 - (c) (1.4 kW Type)
Remove the O-ring.
2. REMOVE STARTER HOUSING, CLUTCH ASSEMBLY AND GEARS
 - (a) Remove the two screws.

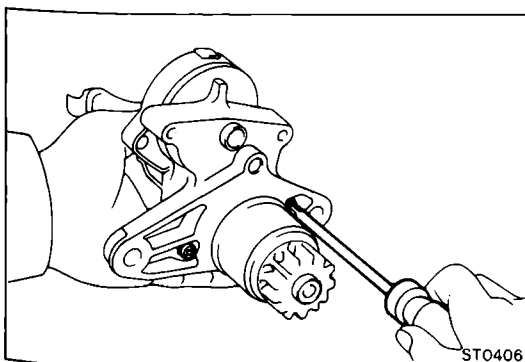

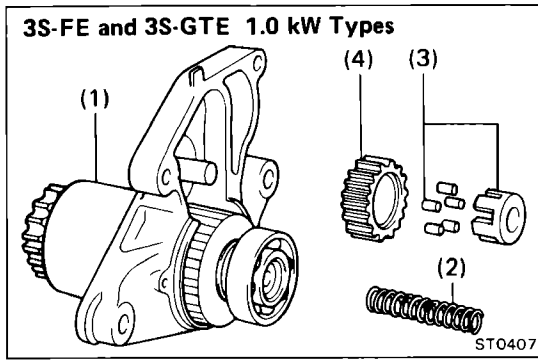

(b) Remove the following parts from the magnetic switch:

(3S-FE and 3S-GTE 1.0 kW Types)

- (1) Starter housing and clutch assembly
- (2) Return spring
- (3) Bearing
- (4) Idle gear

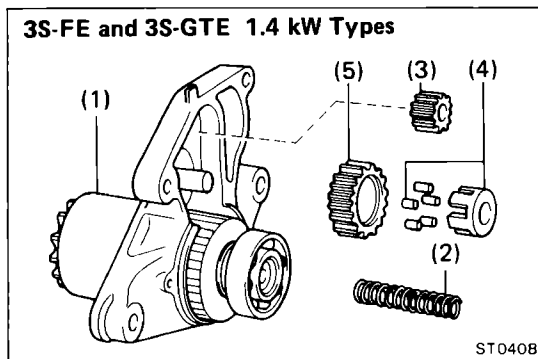

(3S-FE and 3S-GTE 1.4 kW Types)

- (1) Starter housing and clutch assembly
- (2) Return spring
- (3) Pinion gear
- (4) Bearing
- (5) Idle gear

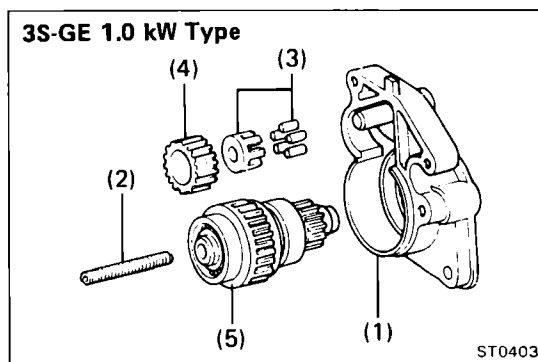

(3S-GE 1.0 kW Type)

- (1) Starter housing
- (2) Return spring
- (3) Bearing
- (4) Idler gear
- (5) Clutch assembly

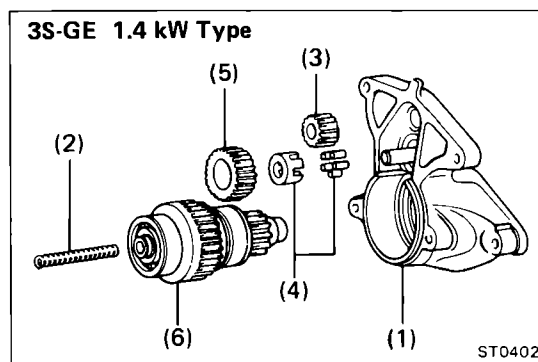

(3S-GE 1.4 kW Type)

- (1) Starter housing
- (2) Return spring
- (3) Pinion gear
- (4) Bearing
- (5) Idler gear
- (6) Clutch assembly

3. REMOVE STEEL BALL

Using a magnetic finger, remove the steel ball from the clutch shaft hole.

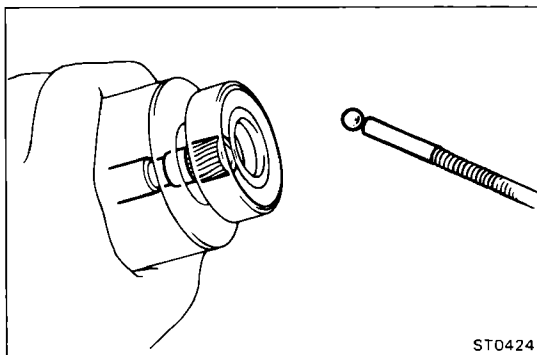

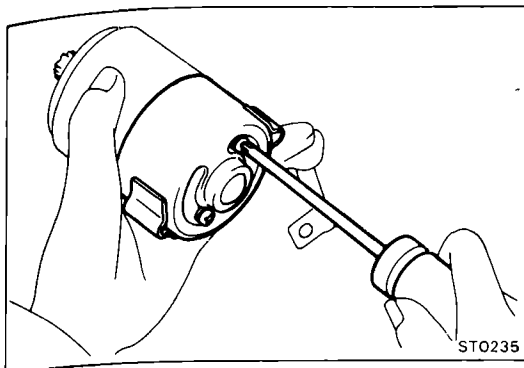

4. REMOVE BRUSH HOLDER

- (a) Remove the two screws and end cover from the field frame.
- (b) (1.4 kW Type)
Remove the O-ring.
- (c) Using a screwdriver, hold the spring back and disconnect the brush from the brush holder. Disconnect the four brushes, and remove the brush holder.

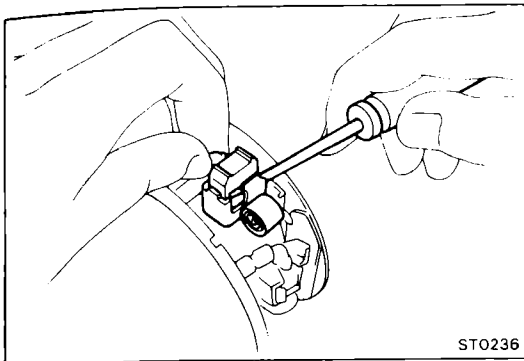

5. REMOVE ARMATURE FROM FIELD FRAME

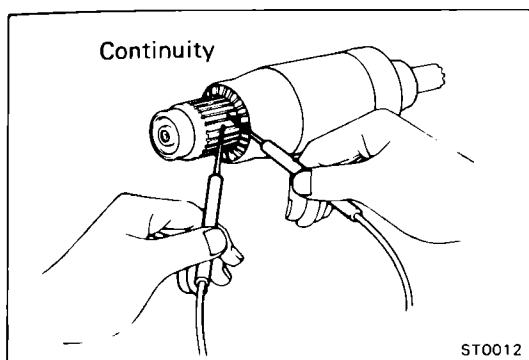

INSPECTION AND REPAIR OF STARTER

Armature Coil

1. INSPECT COMMUTATOR FOR OPEN CIRCUIT

Using an ohmmeter, check that there is continuity between the segments of the commutator.

If there is no continuity, replace the armature.

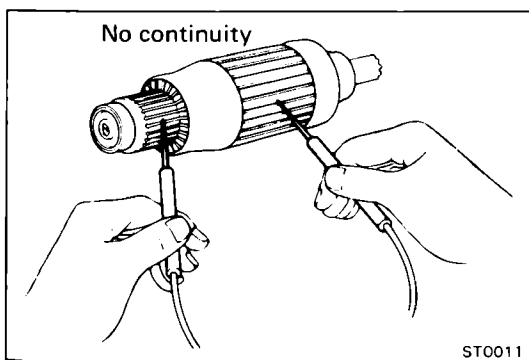

2. INSPECT COMMUTATOR FOR GROUND

Using an ohmmeter, check that there is no continuity between the commutator and armature coil core.

If there is continuity, replace the armature.

Commutator

1. INSPECT COMMUTATOR FOR DIRTY AND BURNT SURFACE

If the surface is dirty or burnt, correct with sandpaper (No.400) or on a lathe.

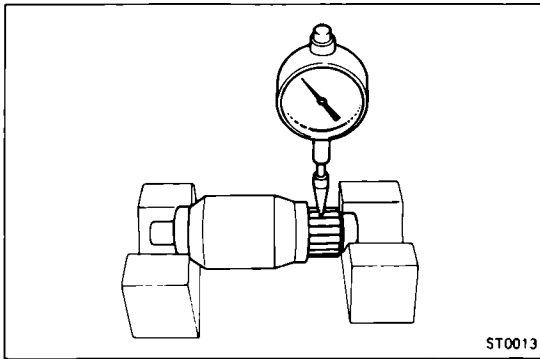

2. INSPECT COMMUTATOR FOR RUNOUT

- (a) Place the commutator on V-blocks.
- (b) Using a dial indicator, measure the circle runout.

Maximum circle runout: 0.05 mm (0.0020 in.)

If the circle runout is greater than maximum, correct it on a lathe.

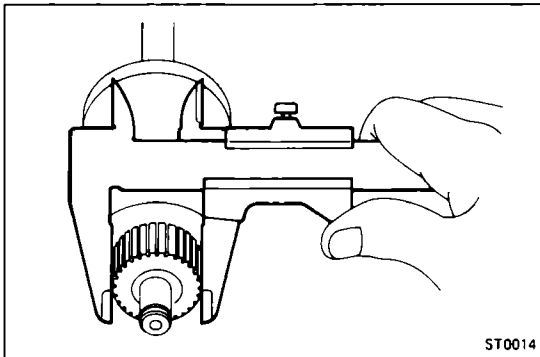

3. INSPECT COMMUTATOR DIAMETER

Using calipers, measure the diameter.

Standard diameter: 30.0 mm (1.142 in.)

Minimum diameter: 29.0 mm (1.181 in.)

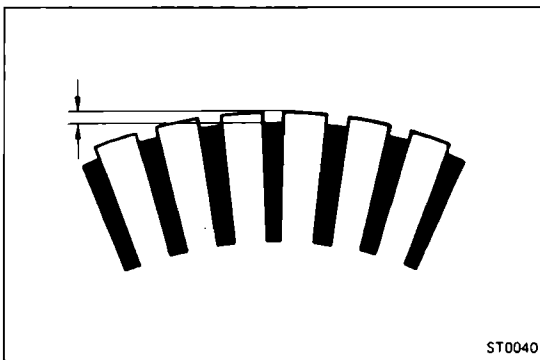

4. INSPECT UNDERCUT DEPTH

Check that the undercut depth is clean and free of foreign material. Smooth out the edge.

Standard undercut depth: 0.6 mm (0.024 in.)

Minimum undercut depth: 0.2 mm (0.008 in.)

If the undercut depth is less than minimum, correct it with a hacksaw blade.

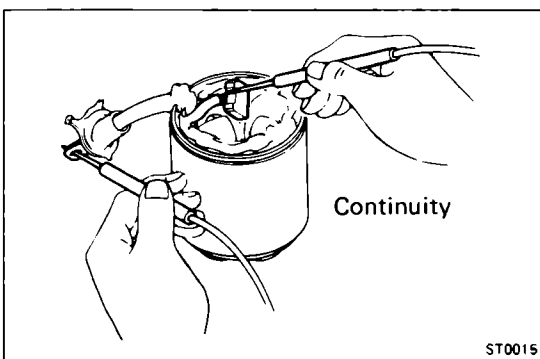

Field Coil (Field Frame)

1. INSPECT FIELD COIL FOR OPEN CIRCUIT

Using an ohmmeter, check that there is continuity between the lead wire and field coil brush lead.

If there is no continuity, replace the field frame.

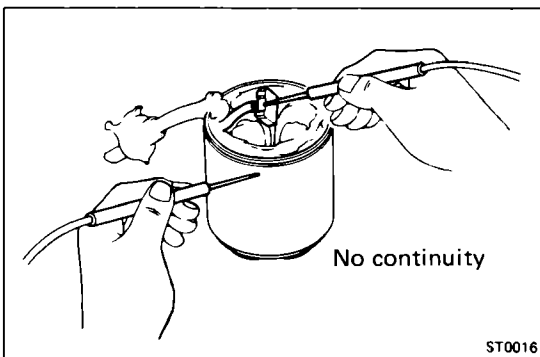

2. INSPECT FIELD COIL FOR GROUND

Using an ohmmeter, check that there is no continuity between the field coil end and field frame.

If there is continuity, replace the field frame.

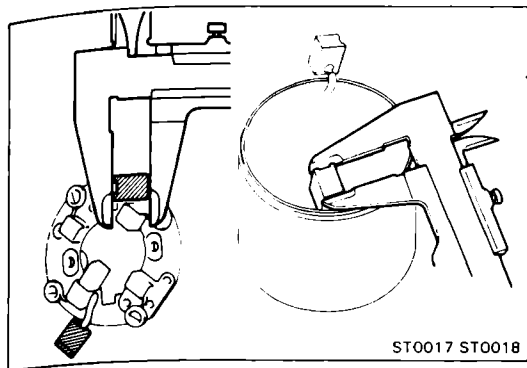

Brushes

INSPECT BRUSH LENGTH

Using calipers, measure the brush length.

Standard length:

1.0 kW type	13.5 mm (0.531 in.)
1.4 kW type	15.5 mm (0.610 in.)

Minimum length:

1.0 kW type	8.5 mm (0.335 in.)
1.4 kW type	10.0 mm (0.394 in.)

If the length is less than minimum, replace the brush holder and field frame.

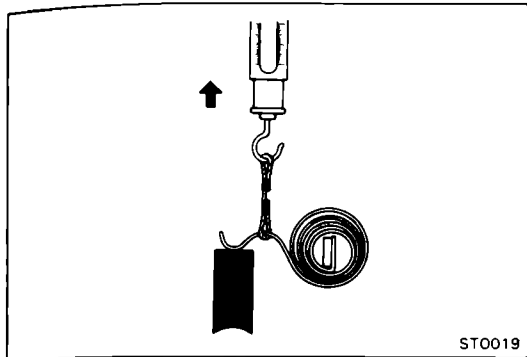

Brush Springs

INSPECT BRUSH SPRING LOAD

Take the pull scale reading the instant the brush spring separates from the brush.

Standard installed load:

1.79 – 2.41 kg (3.9 – 5.3 lb, 18 – 24 N)

If the installed load is not as specified, replace the brush springs.

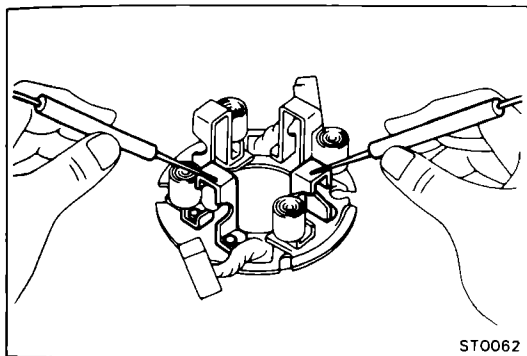

Brush Holder

INSPECT BRUSH HOLDER INSULATION

Using an ohmmeter, check that there is no continuity between the positive (+) and negative (–) brush holders.

If there is continuity, repair or replace the brush holder.

Clutch and Gears

1. INSPECT GEAR TEETH

Check the gear teeth on the pinion gear, idler gear and the clutch assembly for wear or damage.

If damaged, replace the gear or clutch assembly.

If damaged, also check the flywheel ring gear for wear or damage.

2. INSPECT CLUTCH PINION GEAR

Rotate the pinion gear counterclockwise (3S-FE and 3S-GTE) or clockwise (3S-GE) and check that it turns freely. Try to rotate the pinion gear clockwise (3S-FE and 3S-GTE) or counterclockwise (3S-GE) and check that it locks.

If necessary, replace the clutch assembly.

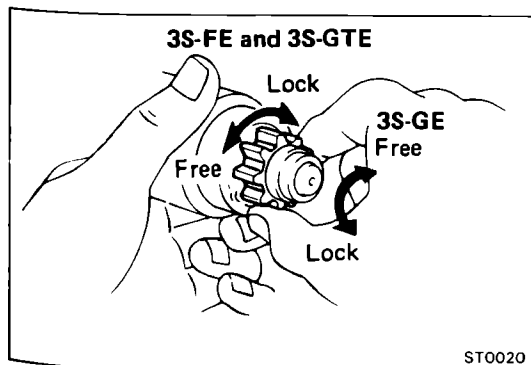

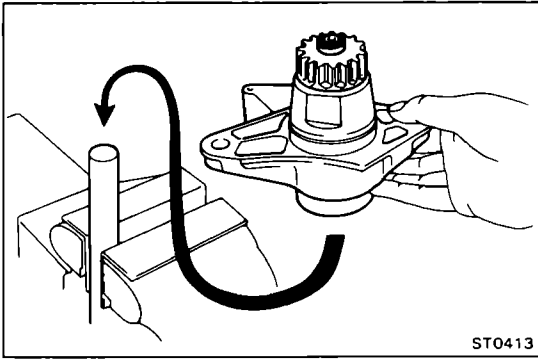

ST0413

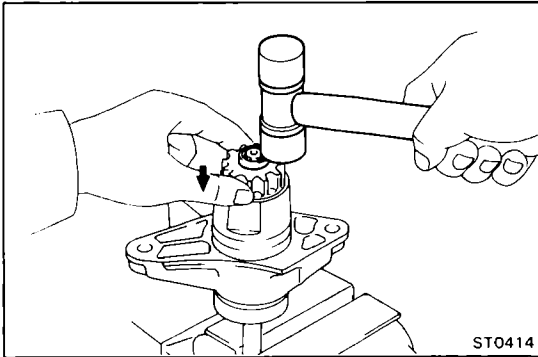

ST0414

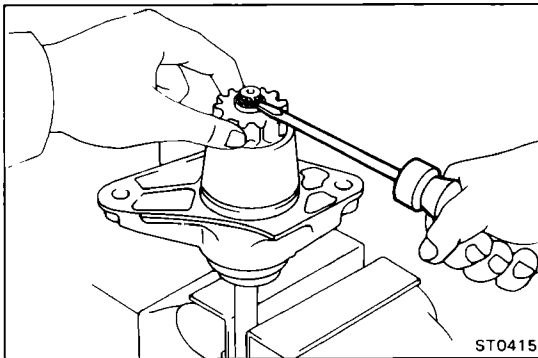

ST0415

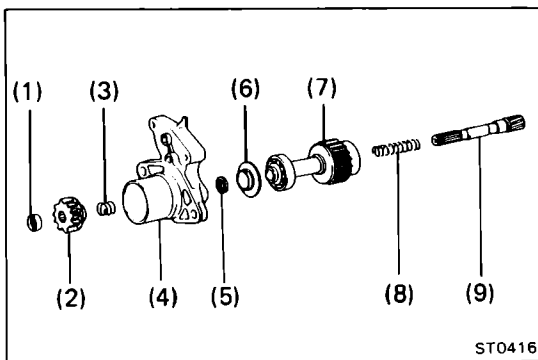

ST0416

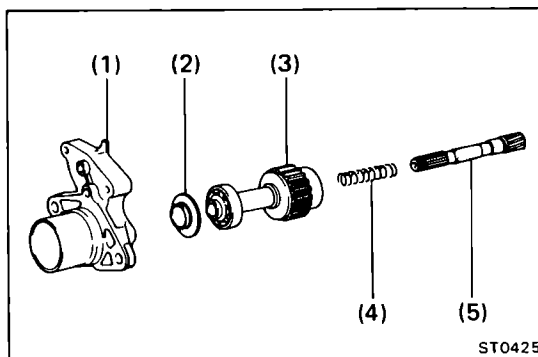

ST0425

3. (3S-FE AND 3S-GTE) IF NECESSARY, REPLACE CLUTCH ASSEMBLY

A. Disassemble starter housing and clutch assembly

(a) Mount a brass bar in a vise, and install the starter housing and clutch assembly to the brass bar.

(b) Push down the pinion gear.

(c) Using a plastic-faced hammer, tap in the stop collar.

(d) Using a screwdriver, pry out the snap ring.

(e) Disassembly the following parts:

- (1) Stop collar
- (2) Pinion gear
- (3) Compression spring
- (4) Starter housing
- (5) Spring retainer
- (6) Bearing retainer
- (7) Starter clutch
- (8) Compression spring
- (9) Clutch shaft

B. Assemble starter housing and clutch assembly

(a) Assemble the following part:

- (1) Starter housing
- (2) Bearing retainer
- (3) Starter clutch
- (4) Compression spring
- (5) Clutch shaft

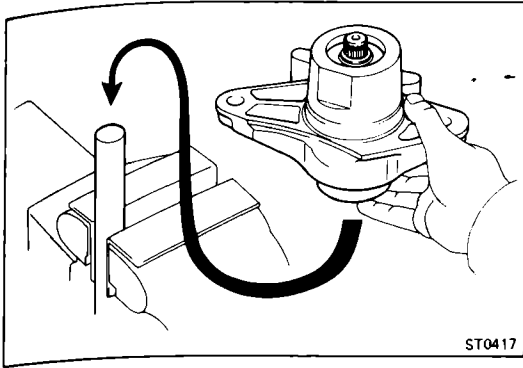

- (b) Mount a brass bar in a vise, install the starter housing and clutch assembly to the brass bar.

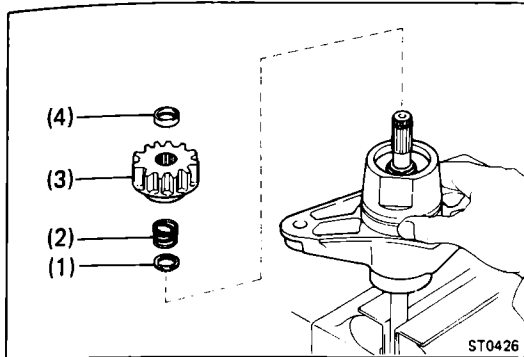

- (c) Push down the starter housing, and install the following parts:
- (1) Spring retainer
 - (2) Compression spring
 - (3) Pinion gear
 - (4) Stop collar

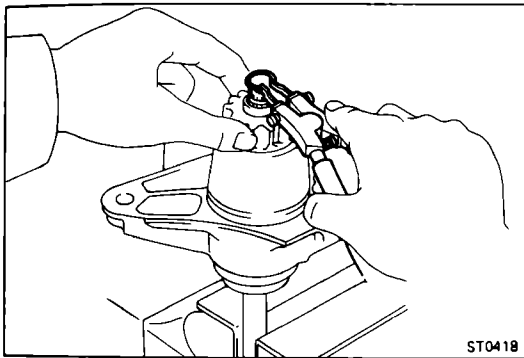

- (d) Push down the pinion gear.
 (e) Using snap ring pliers, install the snap ring.

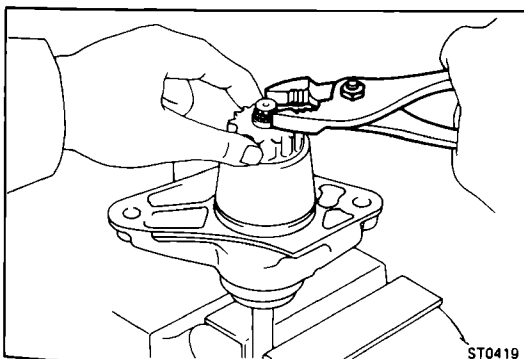

- (f) Using pliers, compress the snap ring.
 (g) Check that the snap ring fits correctly.

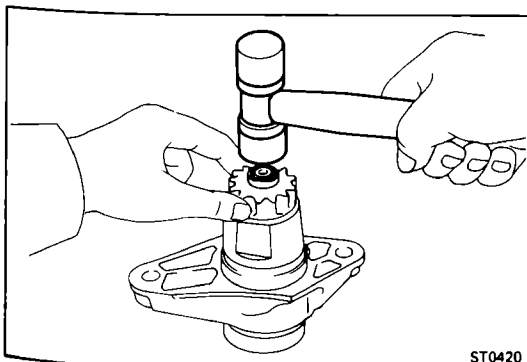

- (h) Remove the starter housing and clutch assembly from the brass bar.
 (i) Using a plastic-faced hammer, tap the clutch shaft and install the stop collar onto the snap ring.

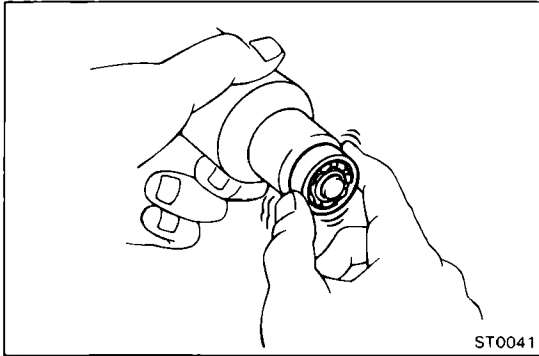

ST0041

Bearings

1. INSPECT BEARINGS

Turn each bearing by hand while applying inward force. If resistance is felt or if the bearing sticks, replace the bearing.

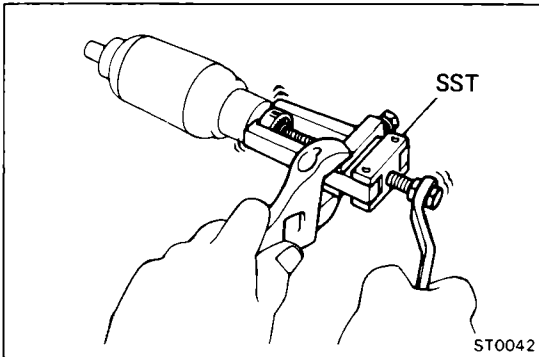

ST0042

2. IF NECESSARY, REPLACE BEARINGS

(a) Using SST, remove the bearing.

SST 09286-46011

(b) Using SST and a press, press in a new front bearing.

SST 1.0 kW Type 09285-76010

1.4 kW Type 09201-41020

(c) Using a press, press in a new rear bearing.

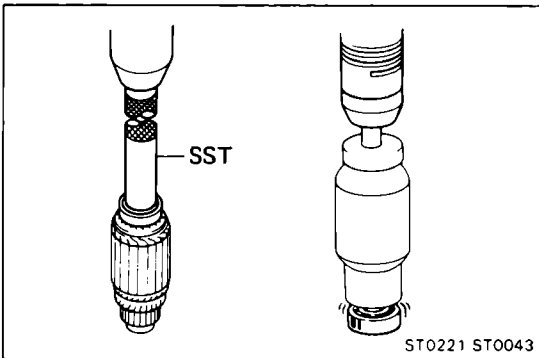

ST0221 ST0043

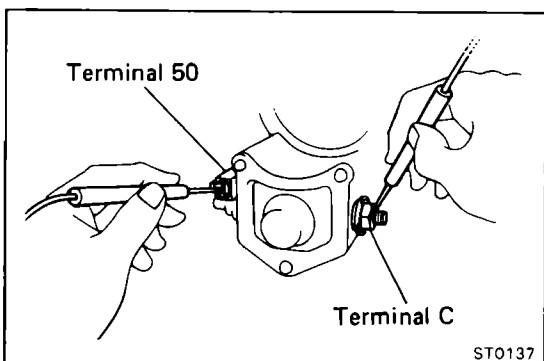

ST0137

Magnetic Switch

1. PERFORM PULL-IN COIL OPEN CIRCUIT TEST

Using an ohmmeter, check that there is continuity between terminals 50 and C.

If there is no continuity, replace the magnetic switch.

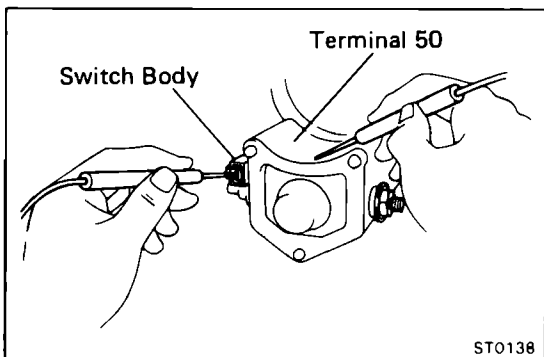

ST0138

2. PERFORM HOLD-IN COIL OPEN CIRCUIT TEST

Using an ohmmeter, check that there is continuity between terminal 50 and the switch body.

If there is no continuity, replace the magnetic switch.

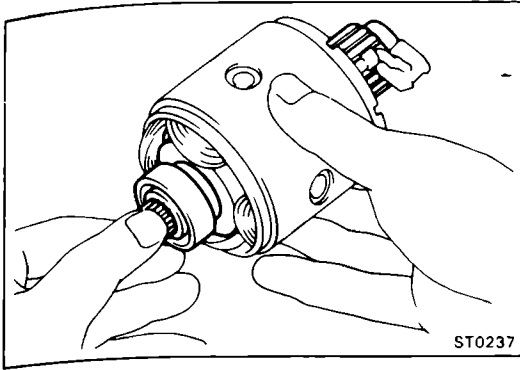

ASSEMBLY OF STARTER

3S-FE and 3S-GTE (See page ST-3)

3S-GE (See page ST-4)

NOTE: Use high-temperature grease to lubricate the bearings and gears when assembling the starter.

1. PLACE ARMATURE INTO FIELD FRAME

Apply grease to the armature bearings, and insert the armature into the field frame.

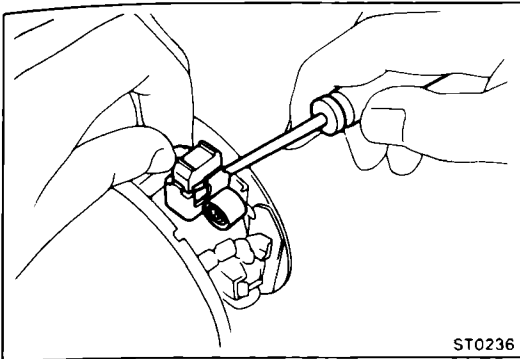

2. INSTALL BRUSH HOLDER

- Place the brush holder in position on the armature.
- Using a screwdriver, hold the brush spring back, and connect the brush into the brush holder. Connect the four brushes.

NOTE: Check that positive (+) lead wires are not grounded.

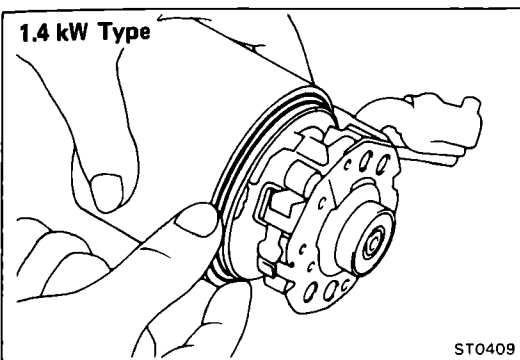

- (1.4 kW Type)

Place a new O-ring in position on the field frame.

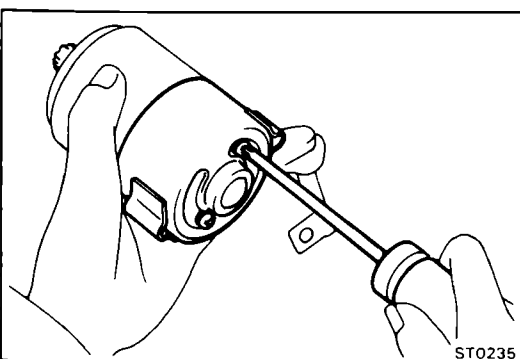

- Install the end cover with the two screws.

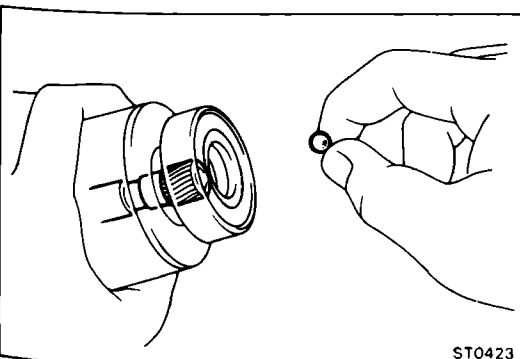

3. INSERT STEEL BALL INTO CLUTCH SHAFT HOLE

- Apply grease to the steel ball.
- Insert the steel ball into the clutch shaft hole.

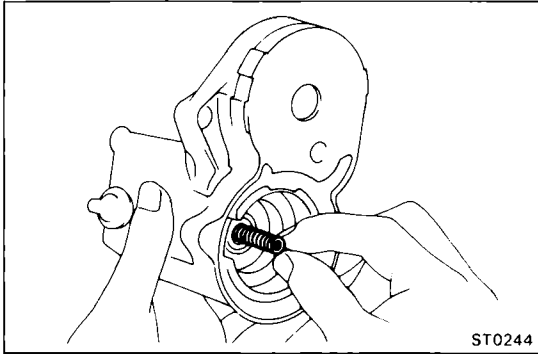

- 4. INSTALL CLUTCH ASSEMBLY (3S-GE) AND GEARS**
- (a) Apply grease to the return spring.
 - (b) Insert the return spring into the magnetic switch hole.

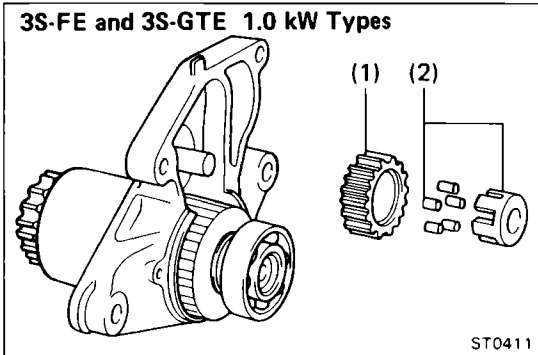

- (c) Place the following parts in position on the starter housing:
(3S-FE and 3S-GTE 1.0 kW Types)
- (1) Idler gear
- (2) Bearing

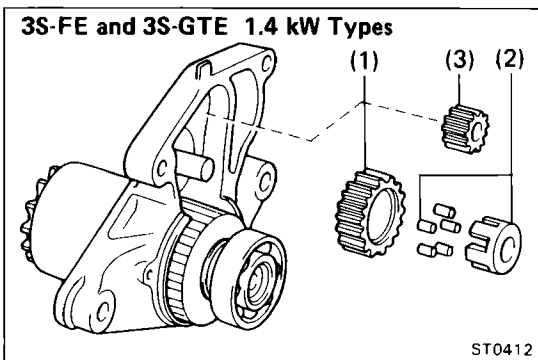

- (3S-FE and 3S-GTE 1.4 kW Types)
- (1) Idler gear
- (2) Bearing
- (3) Pinion gear

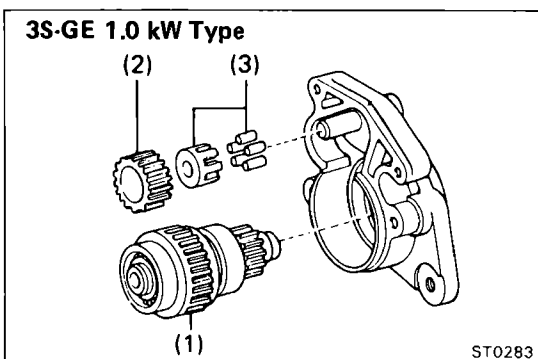

- (3S-GE 1.0 kW Type)
- (1) Clutch assembly
- (2) Idler gear
- (3) Bearing

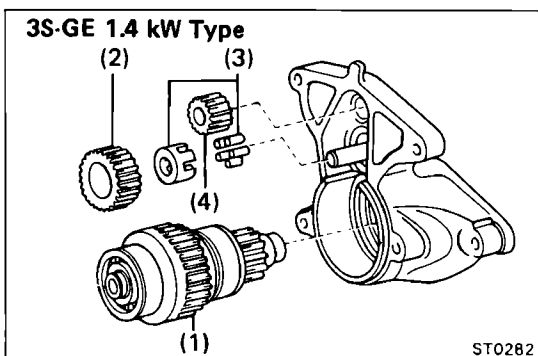

- (3S-GE 1.4 kW Type)
- (1) Clutch assembly
- (2) Idler gear
- (3) Bearing
- (4) Pinion gear

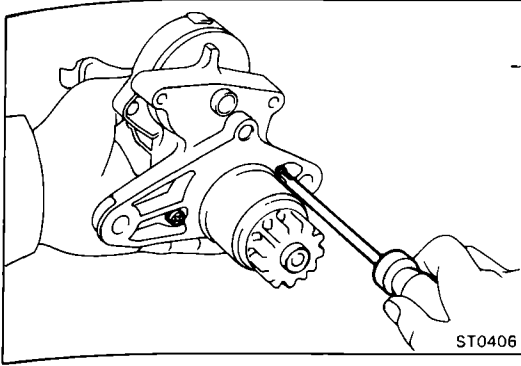

- (d) Assemble the starter housing and magnetic switch with the two screws.

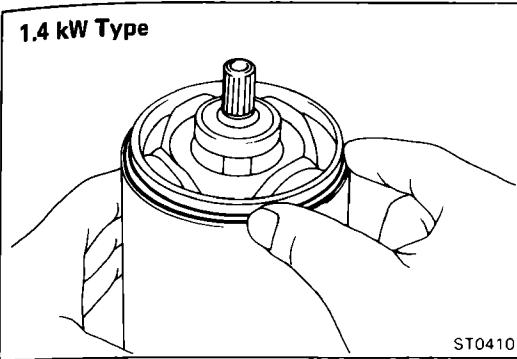

5. INSTALL FIELD FRAME AND ARMATURE ASSEMBLY

- (a) (1.4 kW Type)
Place a new O-ring in position on the field frame.

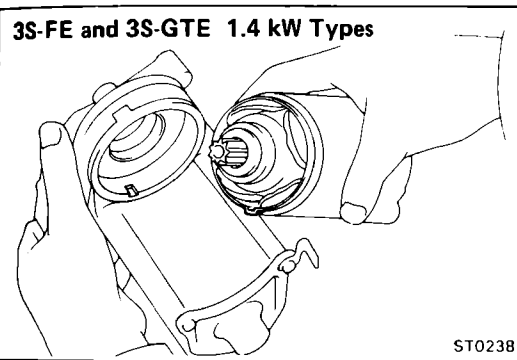

- (b) Align the protrusion of the field frame with the cutout of the magnetic switch.

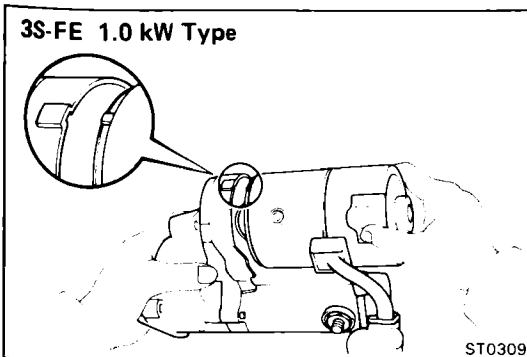
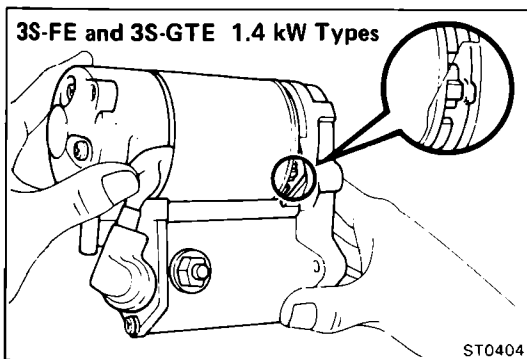

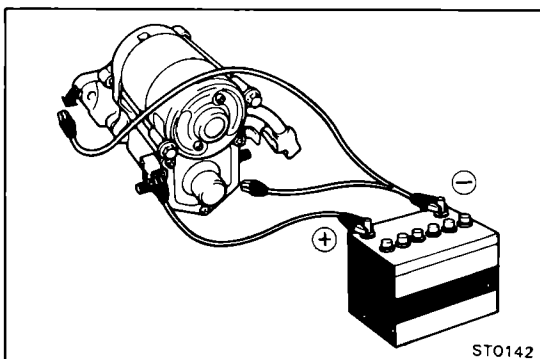
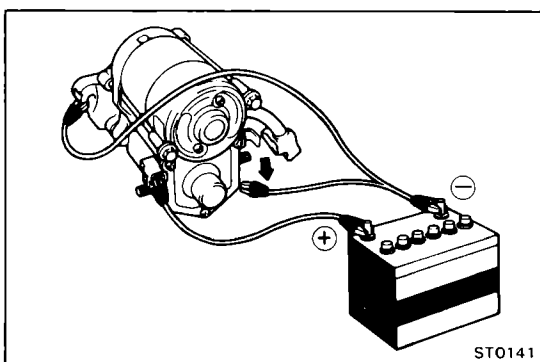
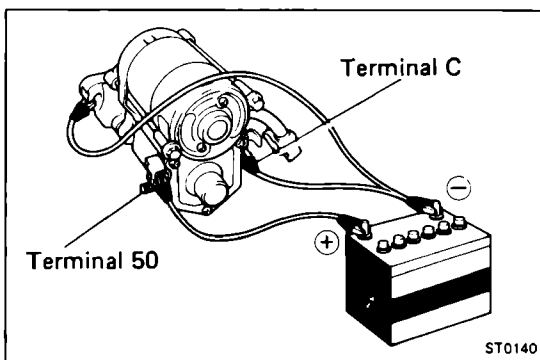
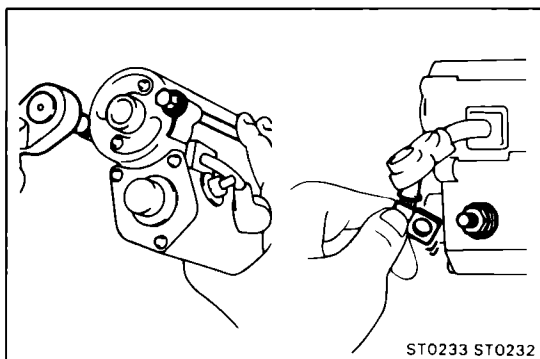
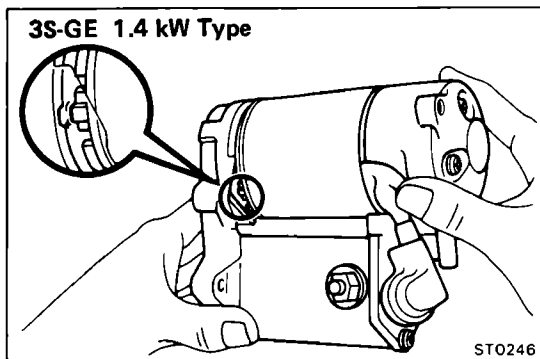

- (c) Install the field frame and armature assembly with the two through bolts.
- (d) Connect the lead wire to terminal C, and install the nut.

PERFORMANCE TEST OF STARTER

CAUTION: These tests must be performed within 3 to 5 seconds to avoid burning out the coil.

1. PERFORM PULL-IN TEST

- (a) Disconnect the field coil lead wire from terminal C.
- (b) Connect battery to the magnetic switch as shown. Check that the pinion gear moves outward.

If the pinion gear does not move, replace the magnetic switch.

2. PERFORM HOLD-IN TEST

While connected as above with the pinion gear out, disconnect the negative (—) lead from terminal C. Check that the pinion gear remains out.

If the pinion gear returns inward, replace the magnetic switch.

3. INSPECT PLUNGER RETURN

Disconnect the negative (—) lead from the switch body. Check that the pinion gear returns inward.

If the pinion gear does not return, replace the magnetic switch.

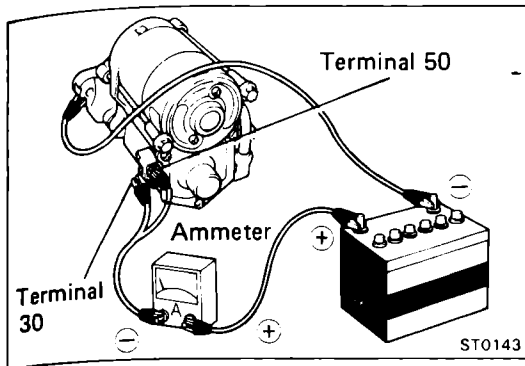

4. PERFORM NO-LOAD PERFORMANCE TEST

- (a) Connect battery and ammeter to the starter as shown.
- (b) Check that the starter rotates smoothly and steadily with the pinion gear moving out. Check the reading on the ammeter.

Standard amperage: 90 A or less at 11.5 V

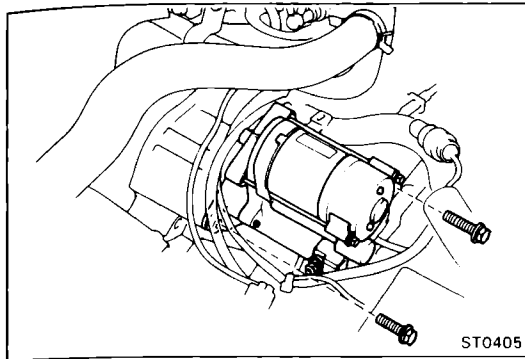

INSTALLATION OF STARTER (3S-FE and 3S-GTE)

1. INSTALL STARTER

Install the starter with the two bolts.

Torque: 400 kg-cm (29 ft-lb, 39 N·m)

2. CONNECT CONNECTOR AND WIRE TO STARTER

3. (3S-GTE)

INSTALL AIR CLEANER ASSEMBLY
(See step 21 on page EM-51)

4. INSTALL BATTERY

5. CHECK THAT ENGINE STARTS

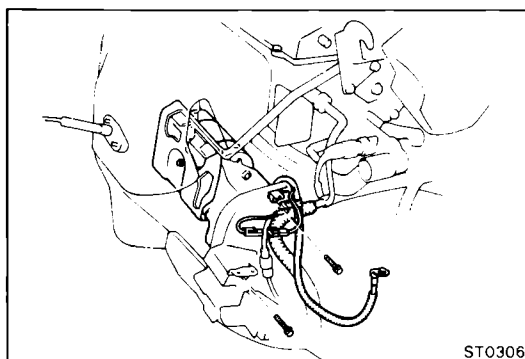

INSTALLATION OF STARTER (3S-GE)

1. INSTALL STARTER

- (a) Install the starter cable to the starter.
- (b) Install the starter cover to the starter.
- (c) Install the starter with the two bolts.

Torque: 400 kg-cm (29 ft-lb, 39 N·m)

2. CONNECT EXHAUST FRONT PIPE TO EXHAUST MANIFOLD (See step 10 on page EM-152)

3. CONNECT CONNECTOR AND CABLE

- (a) Connect the starter connector.
- (b) Connect the cable to the positive (—) terminal of the battery.

4. CONNECT CABLE TO NEGATIVE TERMINAL OF BATTERY

5. CHECK THAT ENGINE STARTS

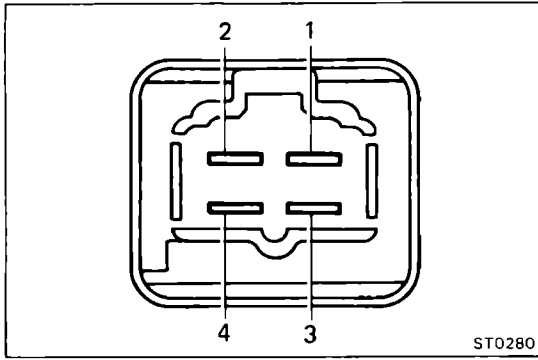

STARTER RELAY (M/T only)

INSPECTION OF STARTER RELAY

LOCATION: In the left cowl side.

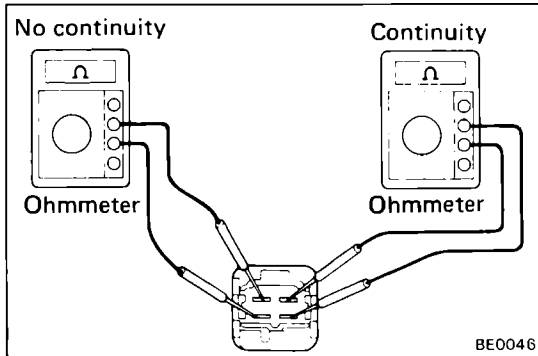

1. INSPECT RELAY CONTINUITY

- Using an ohmmeter, check that there is continuity between terminals 1 and 3.
- Check that there is no continuity between terminals 2 and 4.

If continuity is not as specified, replace the relay.

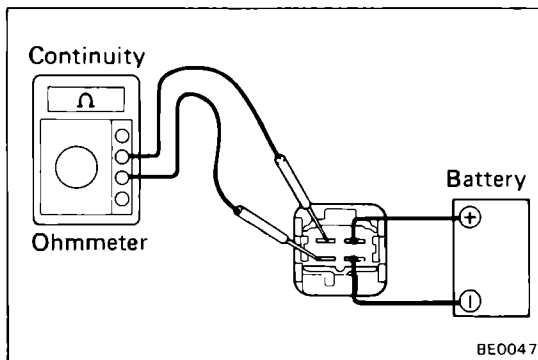

2. INSPECT RELAY OPERATION

- Apply battery voltage across terminals 1 and 3.
- Using an ohmmeter, check that there is continuity between terminals 2 and 4.

If operation is not as specified, replace the relay.

CLUTCH START SWITCH (M/T only)

(See page CL-4)