BODY ELECTRICAL SYSTEM

	Page
GENERAL INFORMATION	BE-2
LOCATION OF SWITCHES AND RELAYS	BE-7
IGNITION SWITCH	BE-14
LIGHTING	BE-15
WIPERS AND WASHERS	BE-25
INSTRUMENTS, GAUGES AND WARNING LIGHTS	BE-30
REAR WINDOW DEFOGGER	BE-40
HEATER	BE-43
POWER WINDOW	BE-53
DOOR LOCK CONTROL SYSTEM	BE-55
SUN ROOF	BE-57
REMOTE CONTROL MIRROR	BE-59
MIRROR HEATER	BE-60
POWER SEAT	BE-60
CRUISE CONTROL SYSTEM	BE-61
AUDIO SYSTEM	BE-87
CLOCK	BE-101

GENERAL INFORMATION

WIRING COLOR CODE

Wire colors are indicated by an alphabetical code.

- | | | |
|------------|------------------|------------|
| B = Black | L = Blue | R = Red |
| BR = Brown | LG = Light Green | V = Violet |
| G = Green | O = Orange | W = White |
| GR = Gray | P = Pink | Y = Yellow |

The first letter indicates the basic wire color and the second letter indicates the color of the stripe.

CONNECTOR

1. PIN NUMBER OF FEMALE CONNECTOR

Numbered in order from upper left to lower right.

2. PIN NUMBER OF MALE CONNECTOR

Numbered in order from upper right to lower left.

3. DISTINCTION OF MALE AND FEMALE CONNECTORS

Male and female connectors are distinguished by shape of their internal pins.

(a) All connectors are shown from the open end, and the lock is on top.

(b) To pull apart the connectors, pull on the connector itself, not the wires.

Example:

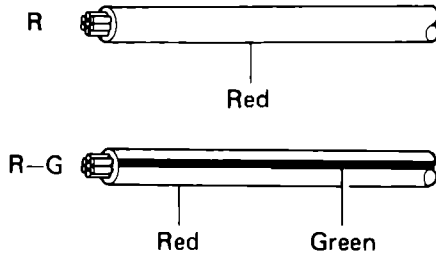

BE1359

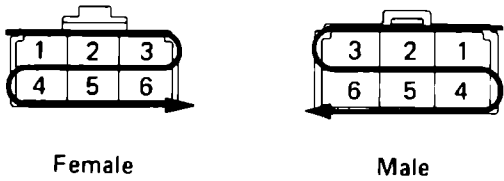

Female

Male

BE0832

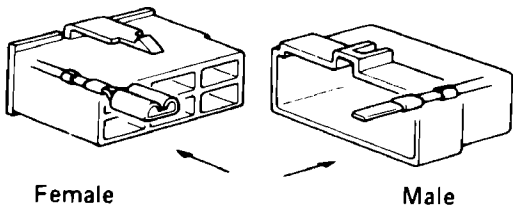

Female

Male

BE0833

WRONG

CORRECT



IN0001

REPLACEMENT OF COMBINATION SWITCH

REMOVE TERMINALS FROM CONNECTOR

(a) From the open end, insert a miniature screwdriver between the locking lugs and terminal.

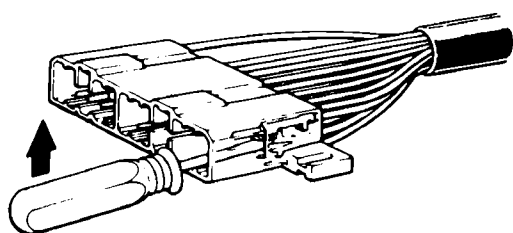

BE0163

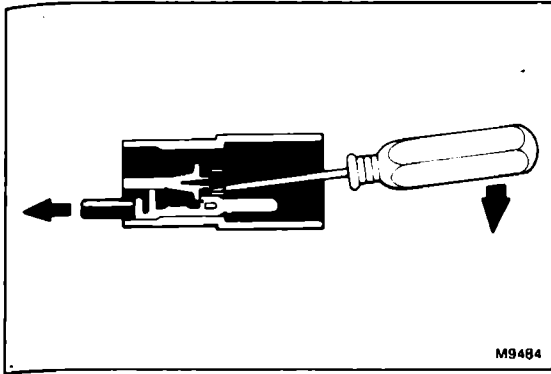

- (b) Pry up the locking lugs with the screwdriver and pull the terminal out from the rear.

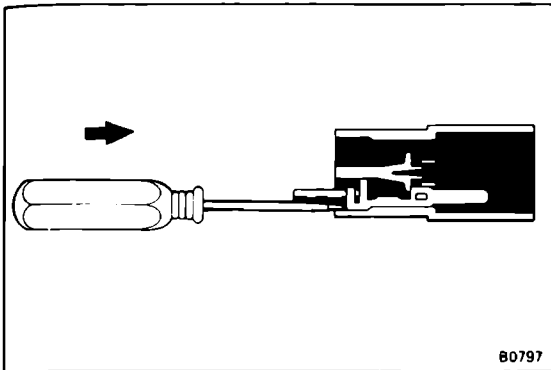

INSTALL TERMINALS TO CONNECTOR

- (a) Push in the terminal until it is securely locked in the connector lug.
- (b) Pull on the wire to confirm that it is securely locked.

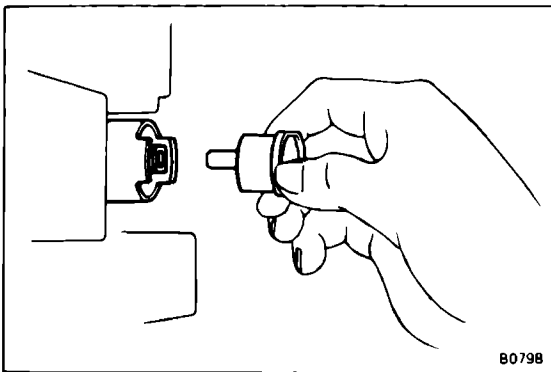

RESET CIRCUIT BREAKER

1. REMOVE CIRCUIT BREAKER

- (a) Remove the kick panel.
- (b) Remove the circuit breaker.

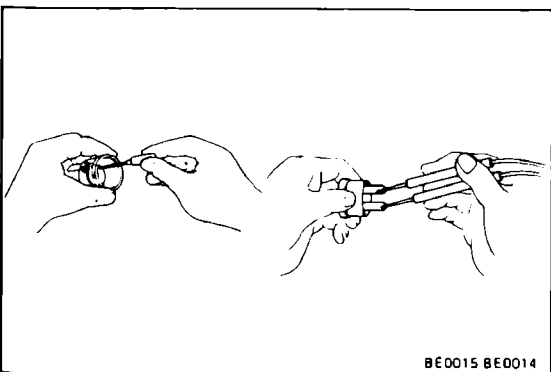

2. RESET CIRCUIT BREAKER

- (a) Insert the needle into the reset hole and push it.
- (b) Using an ohmmeter, check that there is continuity between both terminals of the circuit breaker.

If there is no continuity, replace the circuit breaker.

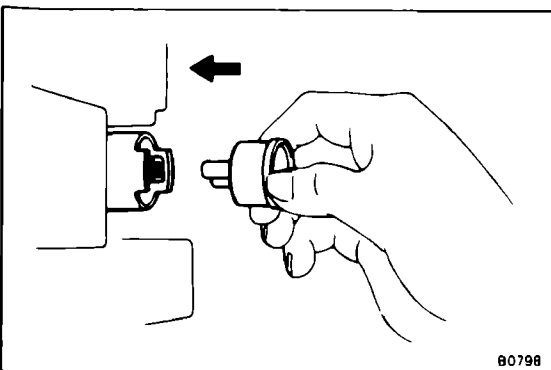

3. INSTALL CIRCUIT BREAKER

- (a) Install the circuit breaker.

NOTE: If a circuit breaker continues to cut out, a short circuit is indicated. Have the system checked by a qualified technician.

- (b) Install the kick panel.

REPLACEMENT OF FUSES

Install new fuses with correct amperage ratings.

CAUTION:

1. Turn off all electrical components and the ignition switch before replacing a fuse. Do not exceed the fuse amp rating.
2. Always use a fuse puller for removing and inserting a fuse. Remove and insert straight in and out without twisting. Twisting could force open the terminals too much, resulting in a bad connection.

If a fuse continues to blow, the circuit is probably shorted. Have the system checked by a qualified technician.

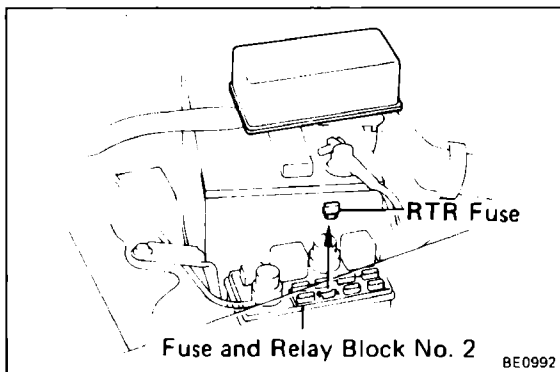

TAKE CARE WHEN INSPECTING HEADLIGHT CIRCUIT

WARNING: With the headlight switch OFF, disconnect the "RTR" (30A) fuse before beginning work.

VOLTAGE CHECK

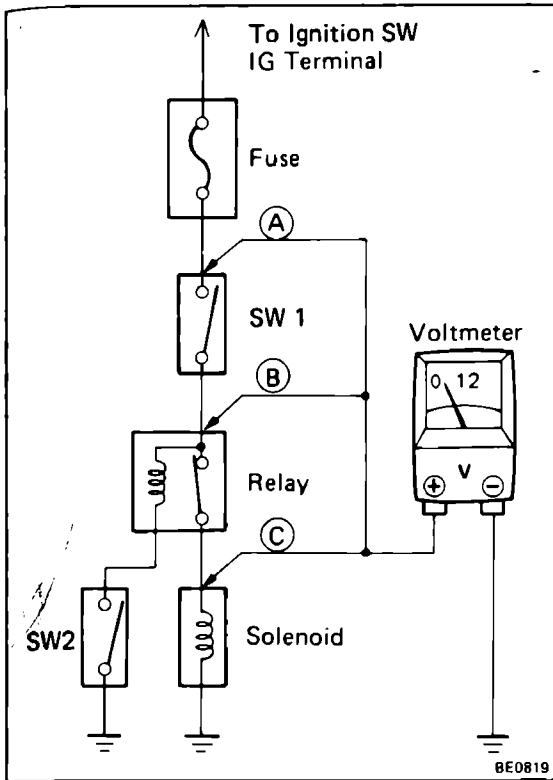

- (a) Establish conditions in which voltage is present at the check point.

Example:

- Ⓐ – Ignition SW on
- Ⓑ – Ignition SW and SW 1 on
- Ⓒ – Ignition SW, SW 1 and Relay on (SW 2 off)

- (b) Using a voltmeter, connect the negative lead to a good ground point or negative battery terminal, and the positive lead to the connector or component terminal. This check can be done with a test light instead of a voltmeter.

CONTINUITY AND RESISTANCE CHECK

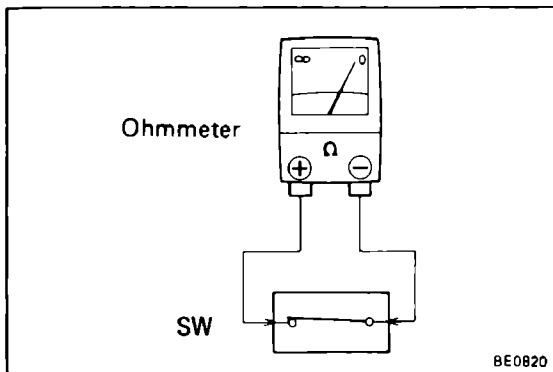

- (a) Disconnect the battery terminal or wire so there is no voltage between the check points.
- (b) Contact the two leads of an ohmmeter to each of the check points.

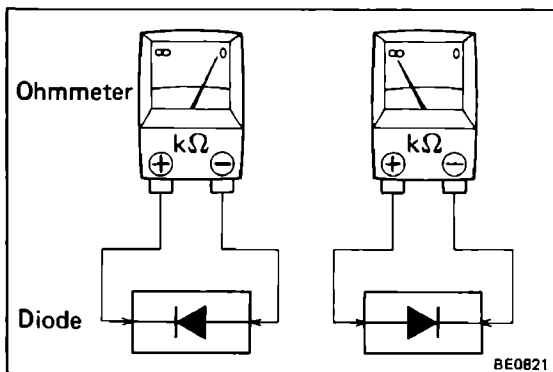

If the circuit has diodes, reverse the two leads and check again.

When contacting the negative (–) lead to the diode positive (+) side and the positive (+) lead to the negative (–) side, there should be continuity.

When contacting the two leads in reverse, there should be no continuity.

NOTE: Specifications may vary depending on the type of tester, so refer to the tester's instruction manual before performing the inspection.

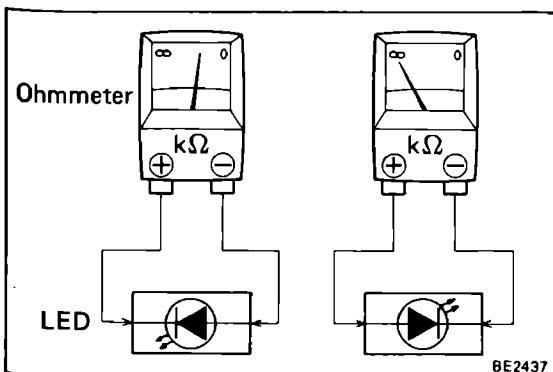

Check LED (Light Emitting Diode) in the same manner as that for diodes.

NOTE:

- Use a tester with a power source of 3 V or greater to overcome the circuit resistance.
- If a suitable tester is not available, apply voltage and check that the LED lights up.

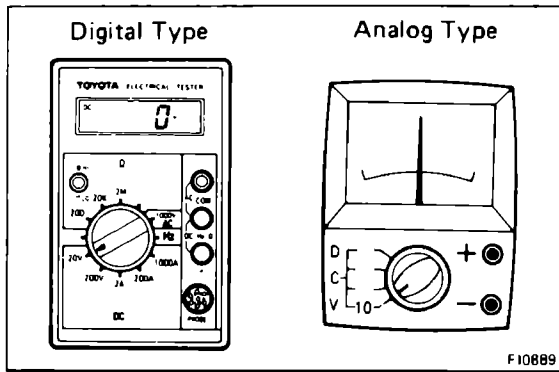

- (c) Use a volt/ohmmeter with high impedance ($10\text{ k}\Omega/\text{V}$ minimum) for troubleshooting of the electrical circuit.

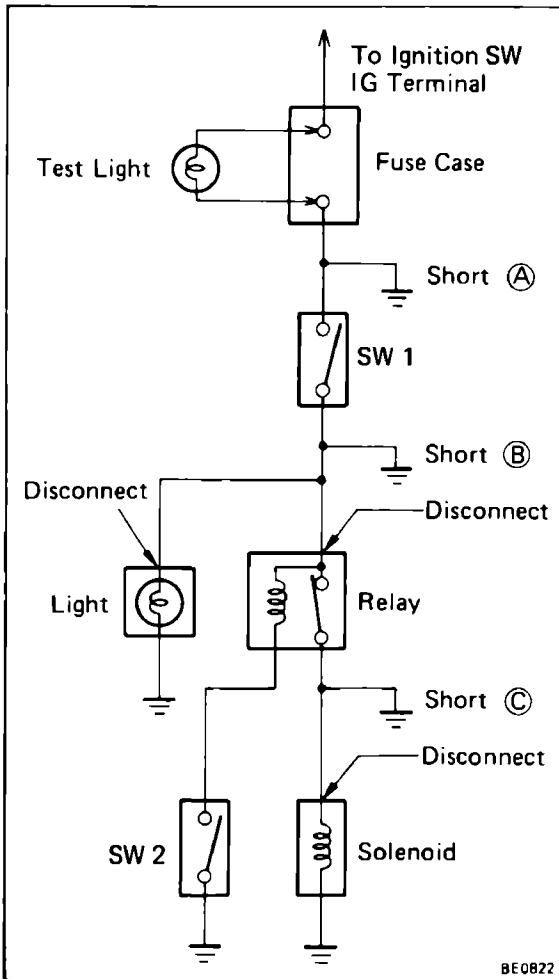

FINDING A SHORT CIRCUIT

- (a) Remove the blown fuse and disconnect all loads of the fuse.
 (b) Connect a test light in place of the fuse.
 (c) Establish conditions in which the test light comes on.

Example:

- (A) – Ignition SW on
 (B) – Ignition SW and SW 1 on
 (C) – Ignition SW, SW 1 and Relay on (Connect the Relay) and SW 2 off (or Disconnect SW 2)

- (d) Disconnect and reconnect the connectors while watching the test light.
 The short lies between the connector where the test light stays lit and the connector where the light goes out.
 (e) Find the exact location of the short by lightly shaking the problem wire along the body.

LOCATION OF SWITCHES AND RELAYS

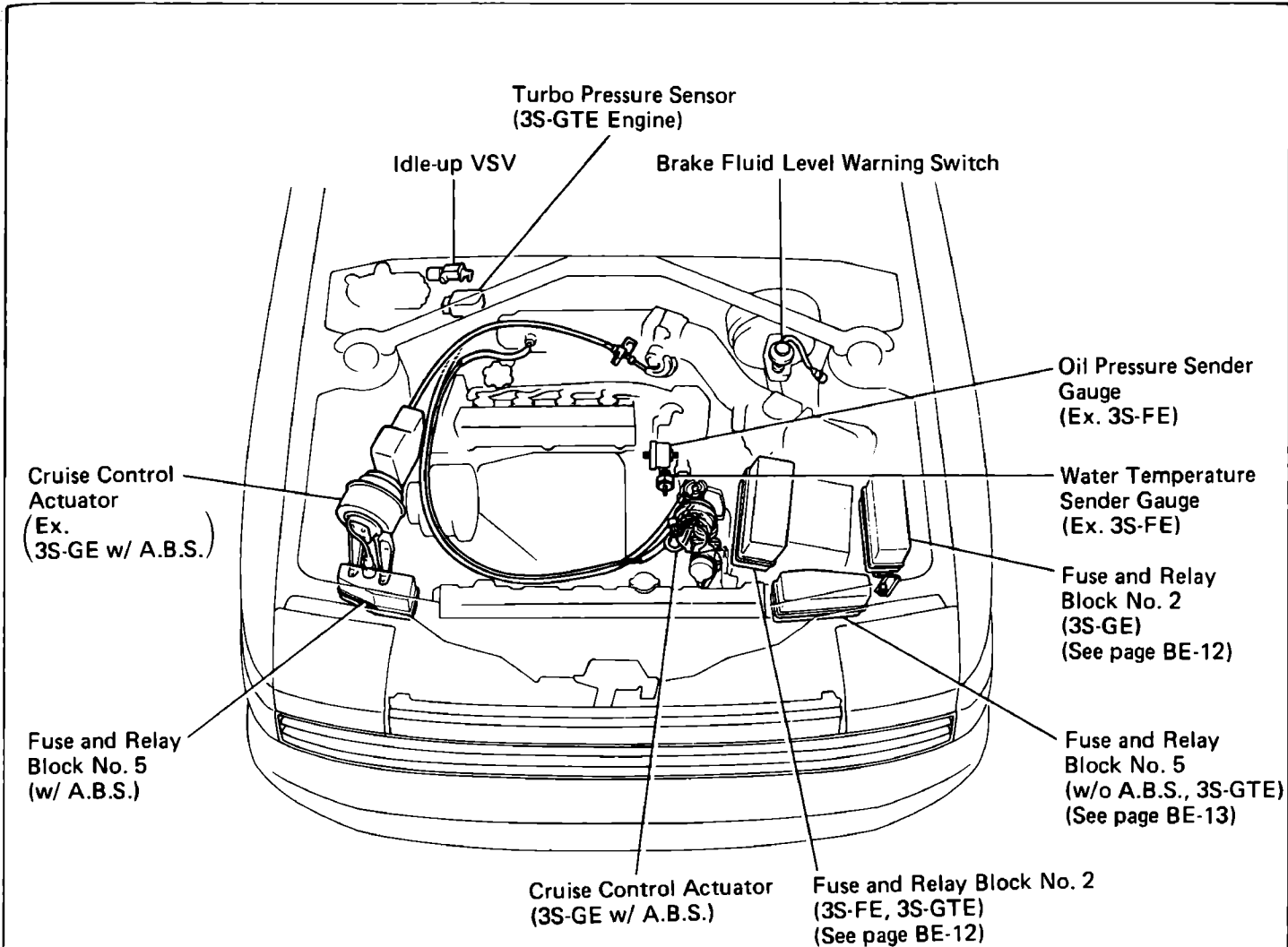

3S-FE Engine

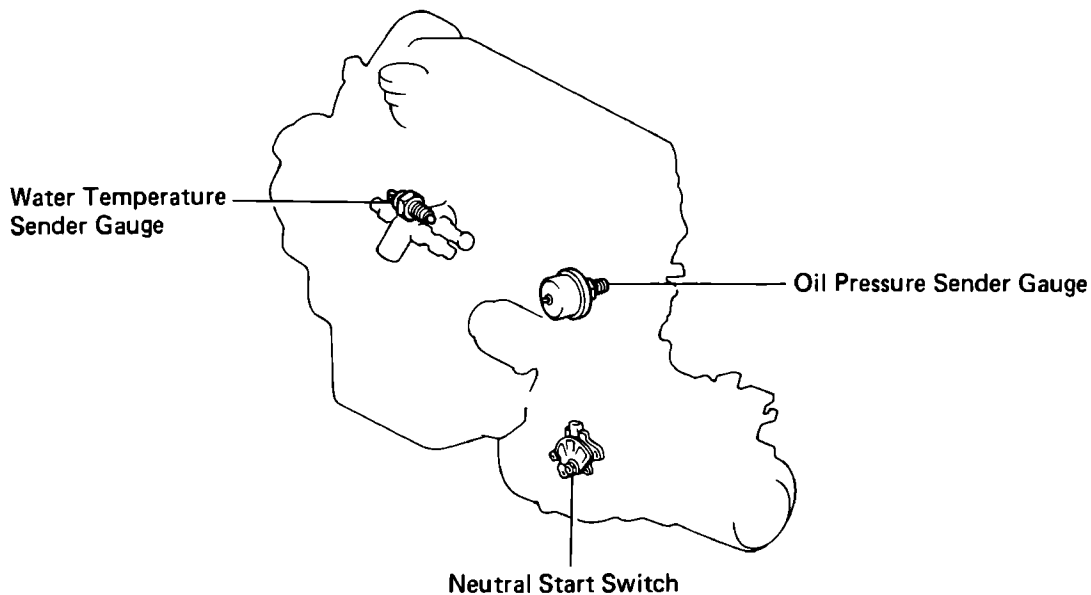

LOCATION OF SWITCHES AND RELAYS (Cont'd)

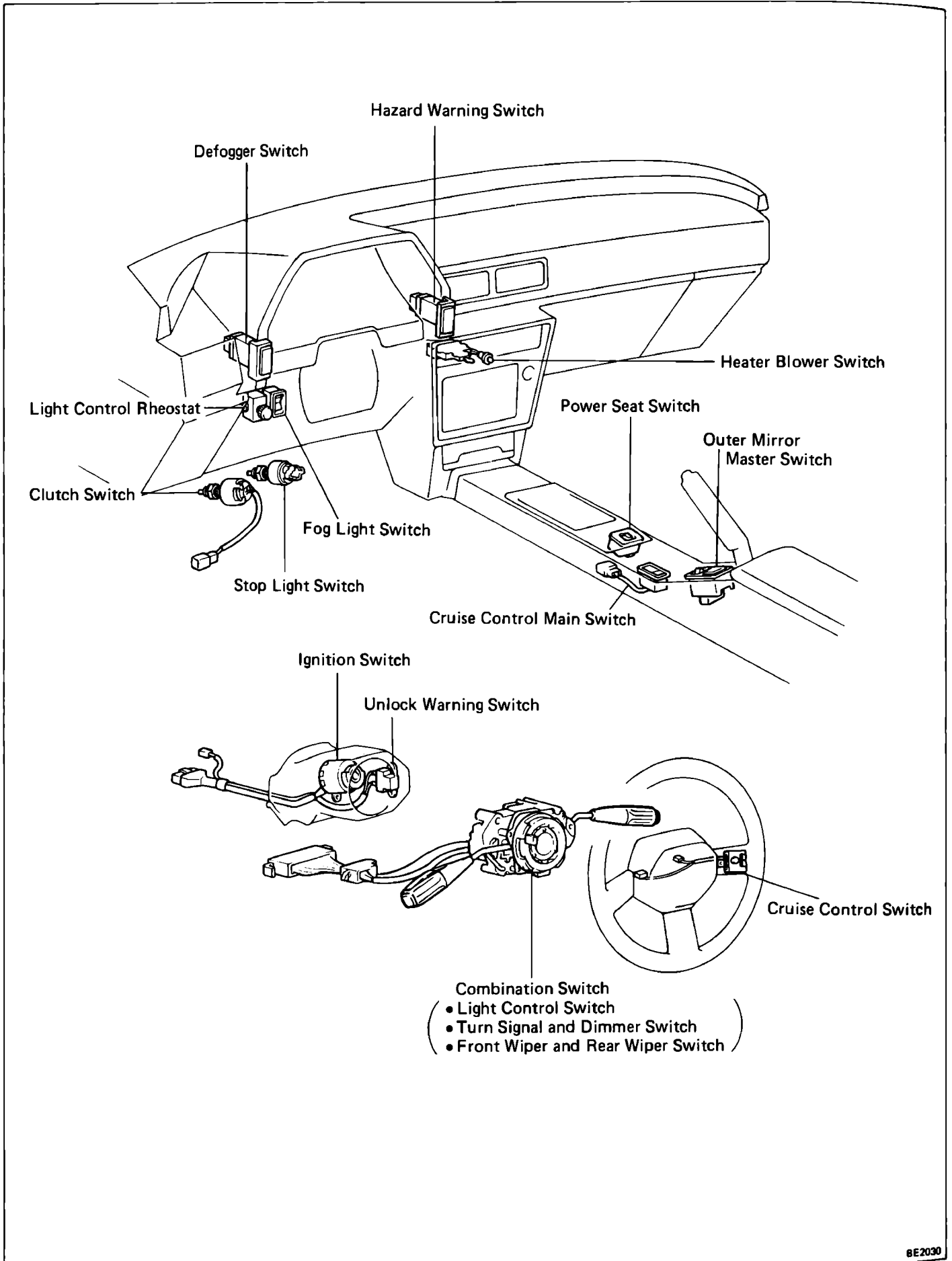

LOCATION OF SWITCHES AND RELAYS (Cont'd)

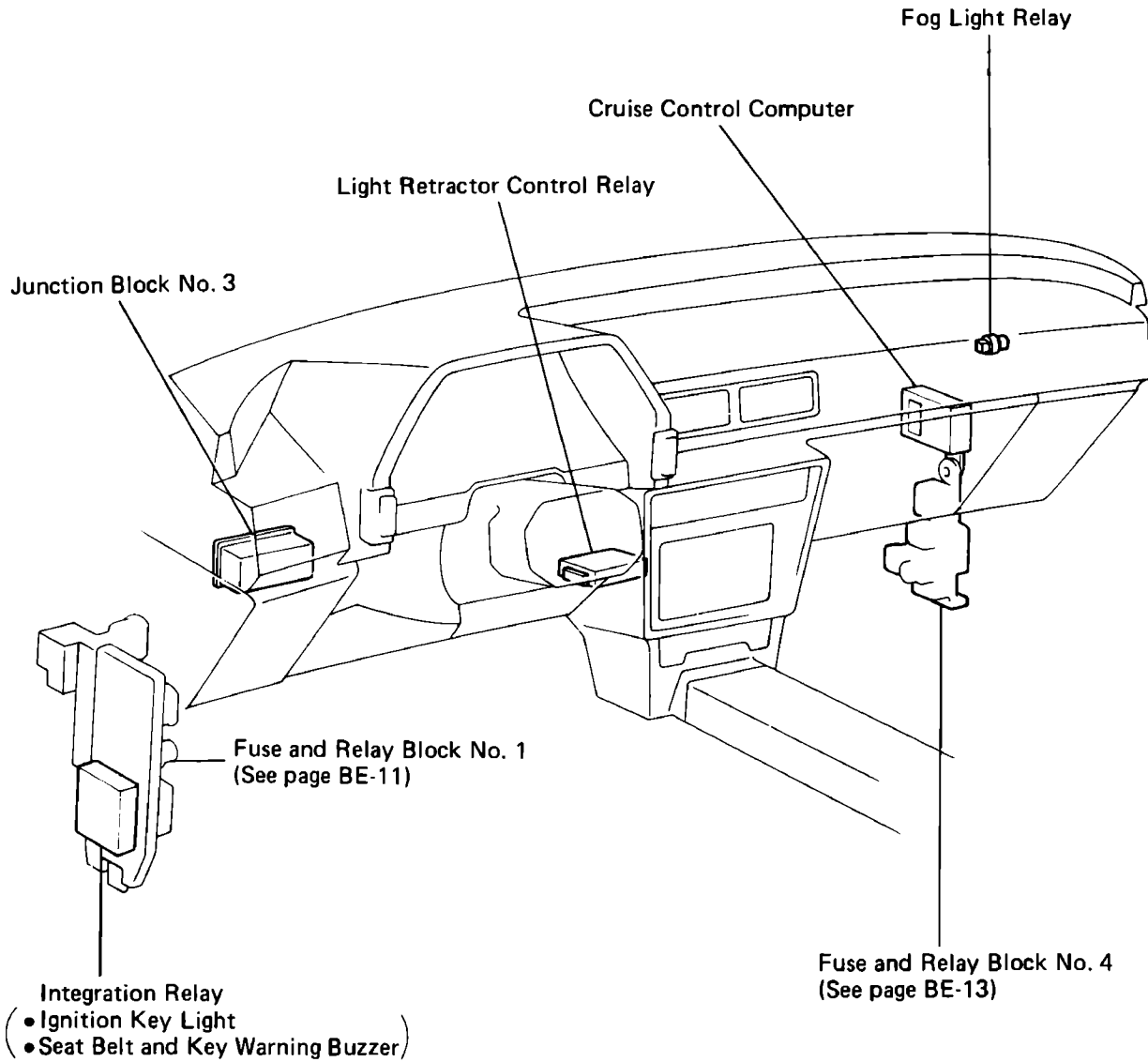

LOCATION OF SWITCHES AND RELAYS (Cont'd)

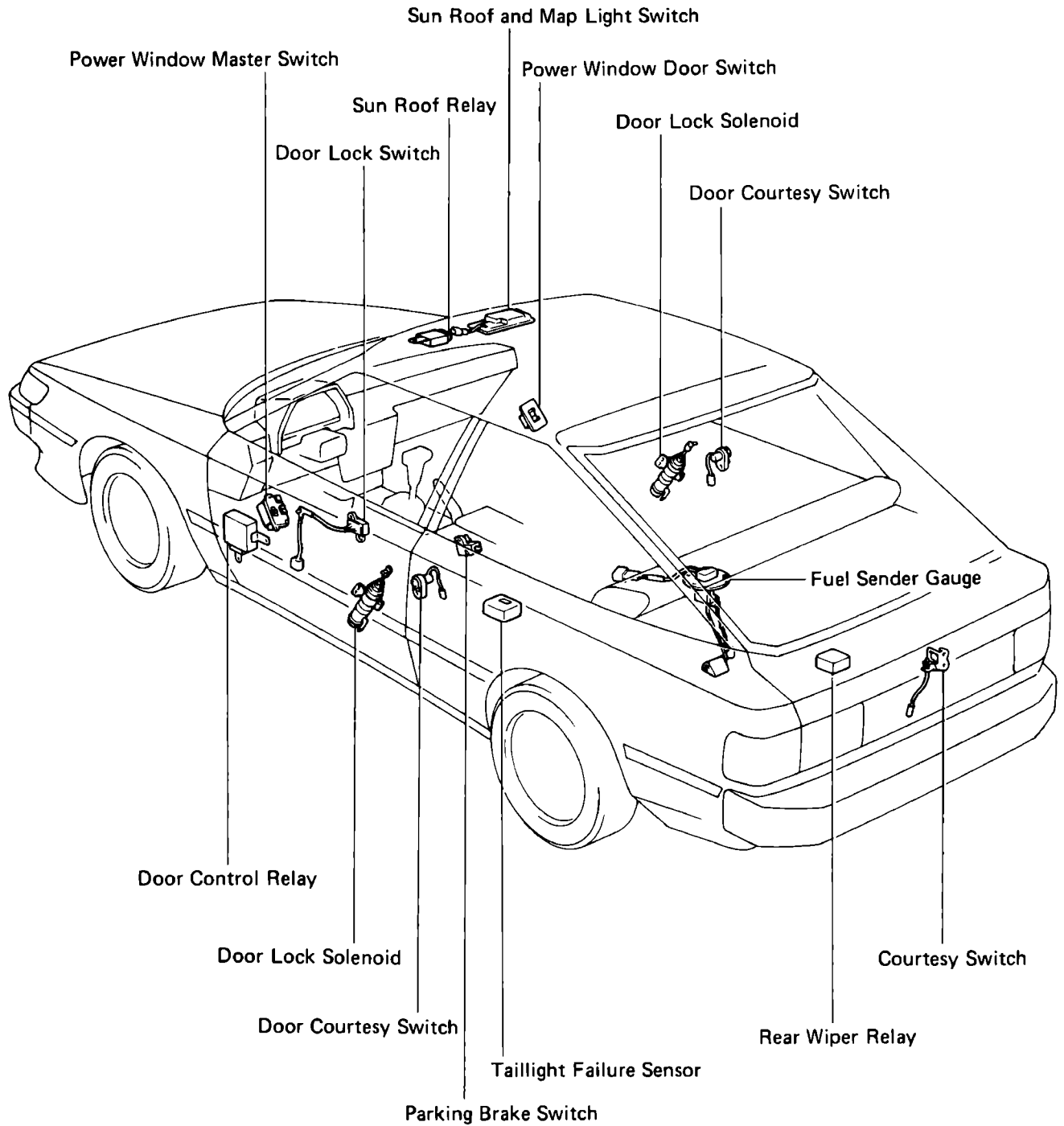

FUSE AND RELAY BLOCKS

FUSE AND RELAY BLOCK NO. 1 (LOCATION: Driver's Side Kick Panel)

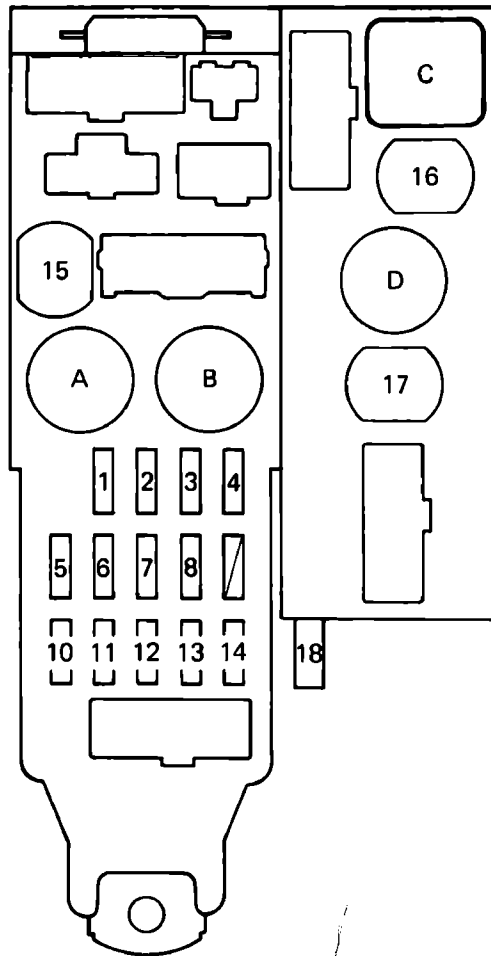

Fuses

- | | | |
|-----|--------------------------------|-------|
| 1. | GAUGE | 15 A |
| 3. | STOP | 15 A |
| 4. | TAIL | 15 A |
| 5. | CIG | 15 A |
| 6. | RADIO | 7.5 A |
| 7. | TURN | 10 A |
| 8. | MIR-HTR | 10 A |
| 10. | ENGINE | 10 A |
| 11. | WIPER | 20 A |
| 12. | ECU-IG | 15 A |
| 14. | IGN | 7.5 A |
| 15. | Circuit Breaker (Defogger) | |
| 16. | Circuit Breaker (Door Lock) | |
| 17. | Circuit Breaker (Power Window) | |
| 18. | FOG | 15 A |

Relays

- | | |
|----|-------------------------|
| A. | Defogger Relay |
| B. | Taillight Control Relay |
| C. | Turn Signal Flasher |
| D. | Clutch Start Relay |

FUSE AND RELAY BLOCKS (Cont'd)

**FUSE AND RELAY BLOCK NO. 2 (LOCATION: Engine Compartment)
(3S-GE Engine)**

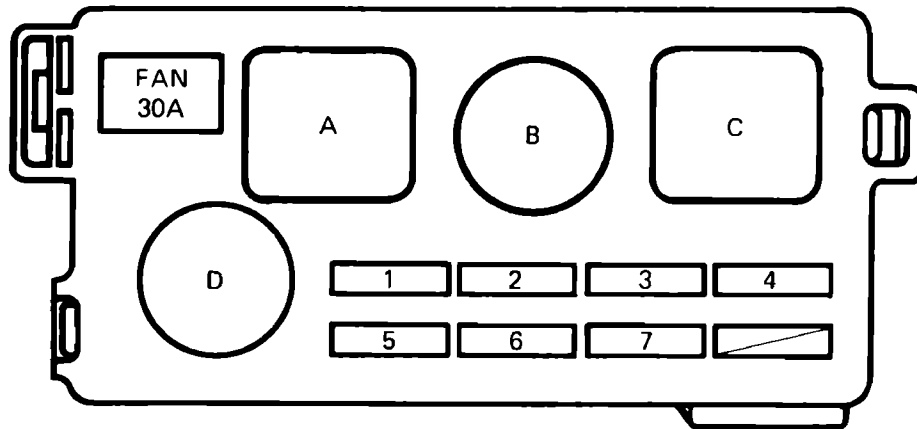

Fuses

- | | |
|--------------|-------|
| 1. HEAD (LH) | 15 A |
| 2. HAZ-HORN | 15 A |
| 3. EFI | 15 A |
| 4. CHARGE | 7.5 A |
| 5. HEAD (RH) | 15 A |
| 6. RTR | 30 A |
| 7. DOME | 20 A |

Relays

- | | |
|----|-------------------------|
| A. | Engine Main Relay |
| B. | EFI Main Relay |
| C. | Headlight Control Relay |
| D. | Fan No. 1 Relay |

(3S-FE, 3S-GTE Engine)

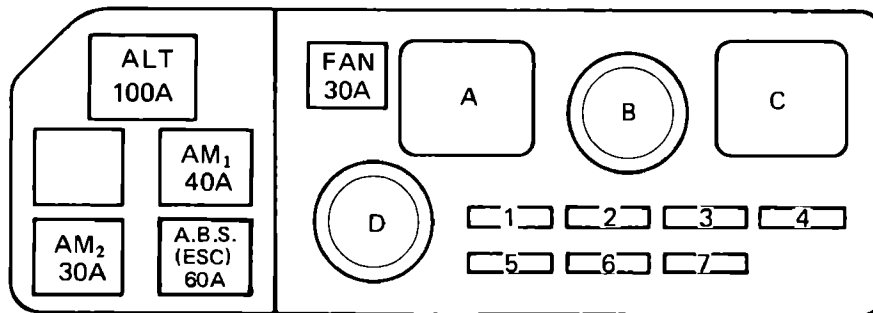

Fuses

- | | |
|--------------|-------|
| 1. HEAD (LH) | 15 A |
| 2. HAZ-HORN | 15 A |
| 3. EFI | 15 A |
| 4. CHARGE | 7.5 A |
| 5. HEAD (RH) | 15 A |
| 6. RTR | 30 A |
| 7. DOME | 20 A |

Relays

- | | |
|----|-------------------------|
| A. | Engine Main Relay |
| B. | EFI Main Relay |
| C. | Headlight Control Relay |
| D. | Fan No. 1 Relay |

FUSE AND RELAY BLOCKS (Cont'd)

FUSE AND RELAY BLOCK NO. 4 (LOCATION: Passenger's Side Kick Panel)

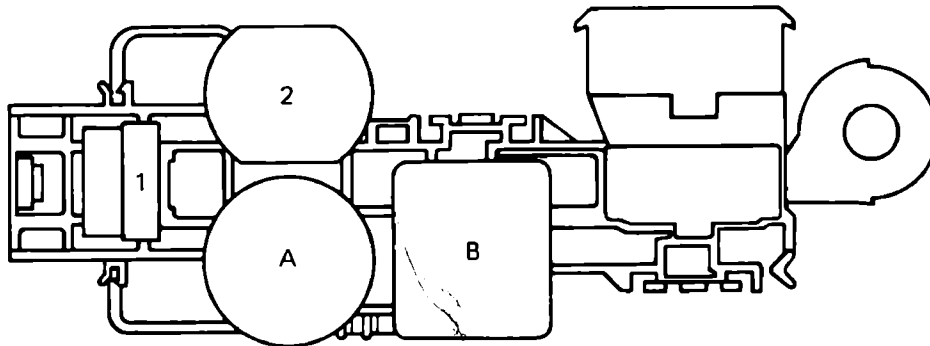

Fuses

- 1. A/C 10 A
- 2. Circuit Breaker (Heater)

Relays

- A. Horn Relay
- B. Heater Relay

FUSE AND RELAY BLOCK NO. 5 (LOCATION: Engine Compartment)

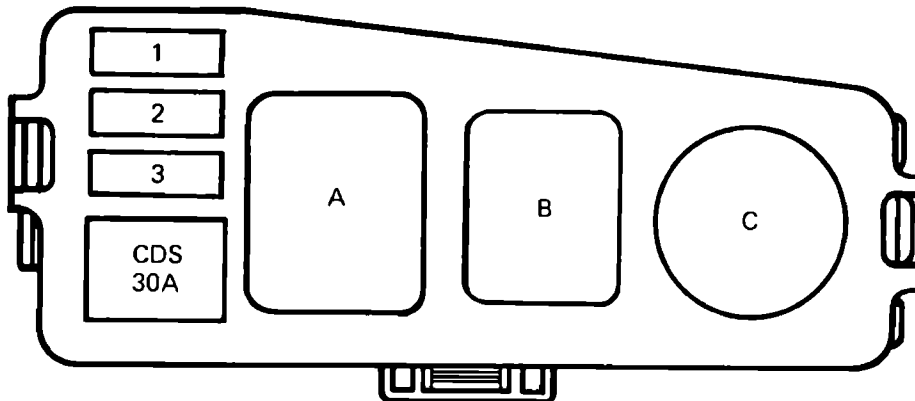

Relays

- A. A/C Fan No. 2 Relay
- B. A/C Magnetic Clutch Relay
- C. A/C Fan No. 3 Relay

IGNITION SWITCH

INSPECTION OF IGNITION SWITCH

INSPECT SWITCH CONTINUITY

Inspect the switch continuity between terminals.

Terminal		Terminal											
		4	3	2	1	8	7	5	9	10			
Switch position	LOCK												
	ACC	○—○											
	ON	○—○—○				○—○							
	START	○—○—○—○				○—○—○							
Unlock Warning	Normal												
	Push										○—○		

If continuity is not as specified, replace the switch.

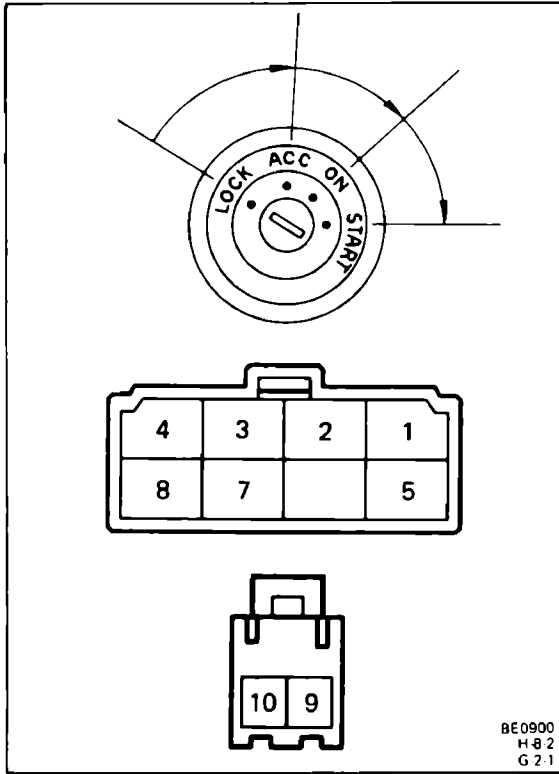

LIGHTING

Troubleshooting

Problem	Possible cause	Remedy	Page
Only one light does not light (all exterior)	Light bulb burned out Socket, wire or ground faulty	Replace bulb Repair as necessary	
Headlights do not flip up	Fusible link blown RTR fuse blown Light retractor control relay faulty Light retractor motor faulty Wiring or ground faulty	Replace fusible link Replace fuse and check for short Check relay Check motor Repair as necessary	BE-4 BE-19 BE-21
No headlights light	Fusible link blown Headlight control relay faulty Light control switch faulty Wiring or ground faulty	Replace fusible link Check relay Check switch Repair as necessary	BE-17 BE-16
High beam headlights or headlight flasher do not operate	Light control switch faulty Wiring faulty	Check switch Repair as necessary	BE-16
Tail, parking and license lights do not light	TAIL fuse blown Fusible link blown Taillight control relay faulty Light control switch faulty Wiring or ground faulty	Replace fuse and check for short Replace fusible link Check relay Check switch Repair as necessary	BE-4 BE-18 BE-16
Stop lights do not light	STOP fuse blown Stop light switch faulty Wiring or ground faulty	Replace fuse and check for short Adjust or replace switch Repair as necessary	BE-4
Stop lights stay on	Stop light switch faulty	Adjust or replace switch	
Instrument lights do not light (taillights light)	Light control rheostat faulty Wiring or ground faulty	Check rheostat Repair as necessary	BE-24
Turn signal does not flash on one side	Turn signal switch faulty Wiring or ground faulty	Check switch Repair as necessary	BE-16
Turn signals do not operate	TURN fuse blown Turn signal flasher faulty Turn signal switch faulty Wiring or ground faulty	Replace fuse and check for short Check flasher Check switch Repair as necessary	BE-4 BE-22 BE-16
Hazard warning lights do not operate	HAZ-HORN fuse blown Turn signal flasher faulty Hazard warning switch faulty Wiring or ground faulty	Replace fuse and check for short Check flasher Check switch Repair as necessary	BE-4 BE-22 BE-21

Light Control Switch, Headlight Dimmer Switch and Turn Signal Switch

INSPECTION OF LIGHT CONTROL SWITCH, HEADLIGHT DIMMER SWITCH AND TURN SIGNAL SWITCH

INSPECT CONTINUITY OF LIGHT CONTROL SWITCH, HEADLIGHT DIMMER SWITCH AND TURN SIGNAL SWITCH

Inspect the switch continuity between terminals.

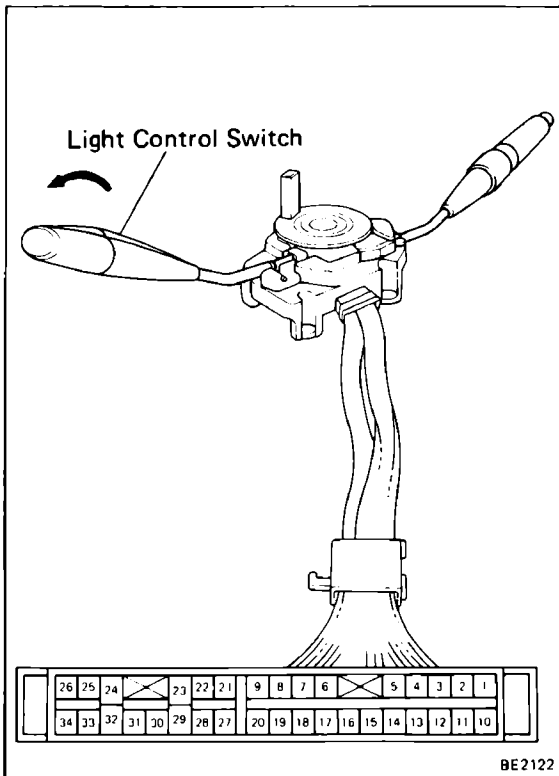

Light control switch

Switch position \ Terminal (Wire color)	31 EL (W)	22 T	23 H (R)	20 U (G)
OFF				
UP	○			○
TAIL	○	○	○	○
HEAD	○	○	○	

Headlight dimmer switch

Switch position \ Terminal (Wire color)	29 Ed (W-B)	23 HL (R-G)	32 Hu (R-Y)	34 Hf (R-W)
Flash	○		○	○
Low Beam	○	○		
High Beam	○		○	

Turn signal switch

Switch position \ Terminal (Wire color)	25 TL (G-B)	21 Tb (G-W)	28 Tr (G-Y)
Left Turn	○	○	
Neutral			
Right Turn		○	○

If continuity is not as specified, replace the switch.

REPLACEMENT OF LIGHT CONTROL SWITCH, HEADLIGHT DIMMER SWITCH AND TURN SIGNAL SWITCH

REPLACE LIGHT CONTROL SWITCH, HEADLIGHT DIMMER SWITCH AND TURN SIGNAL SWITCH

- Remove the terminals from the connector. (See pages BE-2, 3)
- Remove the slip ring (w/Cruise control only).
- Remove the light control switch.
- Remove the headlight dimmer and turn signal switch.

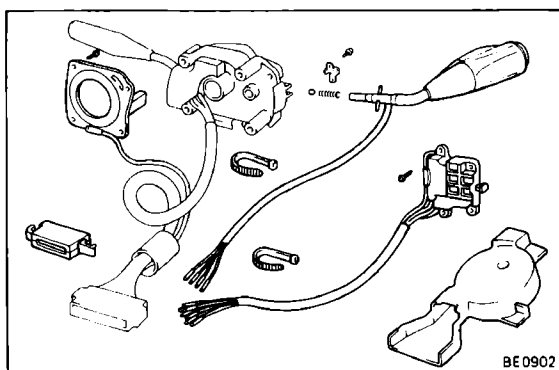

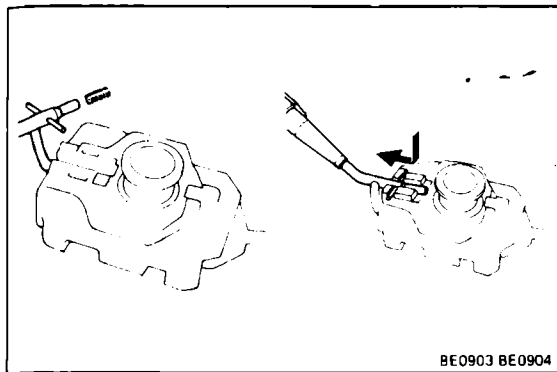

- (e) Install the headlight dimmer switch.
- (f) Insert the spring into the lever, and install the lever.

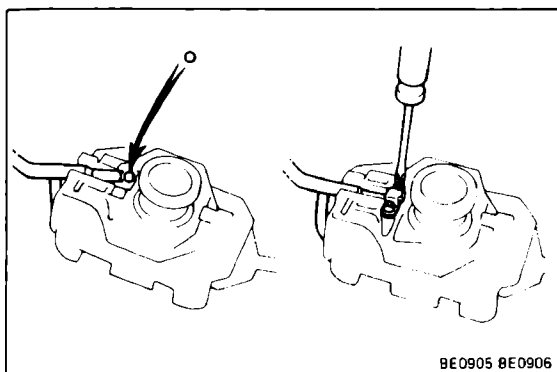

- (g) Place the ball on the spring, position the lever at HI and install the plate with the two screws.

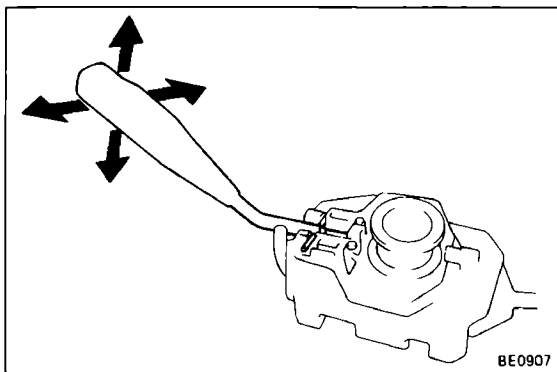

- (h) Insure that the switch operates smoothly.
- (i) Install the slip ring (w/Cruise control only).
- (j) Install the terminals to the connector.
(See pages BE-3, 16)

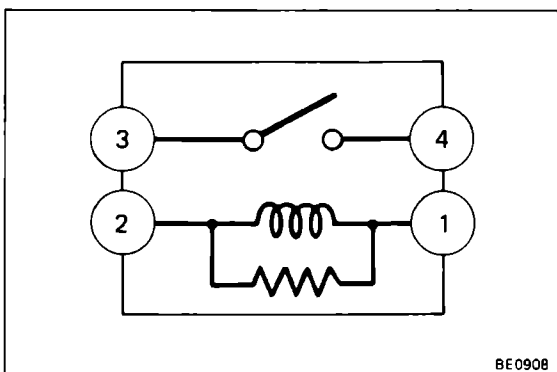

Headlight Control Relay

INSPECTION OF HEADLIGHT CONTROL RELAY

1. INSPECT RELAY CONTINUITY

- (a) Check that there is continuity between terminals 1 and 2.
- (b) Check that there is no continuity between terminals 3 and 4.
- (c) Check that there is no continuity between terminals 1 and 4.

If continuity is not as specified, replace the relay.

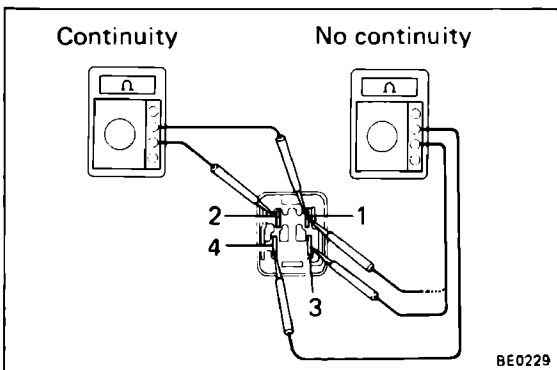

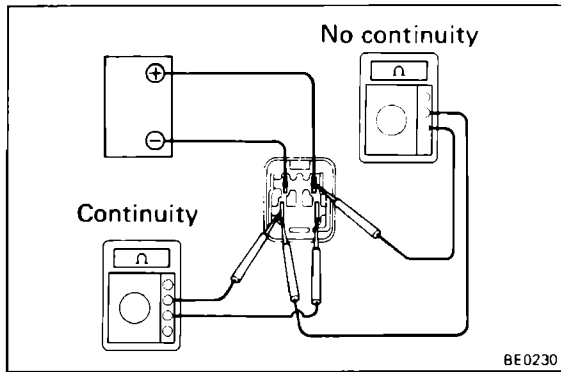

2. INSPECT RELAY OPERATION

- Apply battery voltage across terminals 1 and 2.
- Check that there is continuity between terminals 3 and 4.
- Check that there is no continuity between terminals 1 and 4.

If operation is not as specified, replace the relay.

Taillight Control Relay

INSPECTION OF TAILLIGHT CONTROL RELAY

1. INSPECT RELAY CONTINUITY

- Check that there is continuity between terminals 1 and 3.
- Check that there is no continuity between terminals 2 and 4.
- Check that there is no continuity between terminals 3 and 4.

If continuity is not as specified, replace the relay.

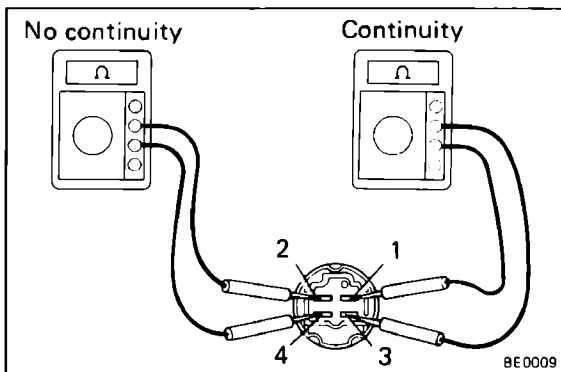
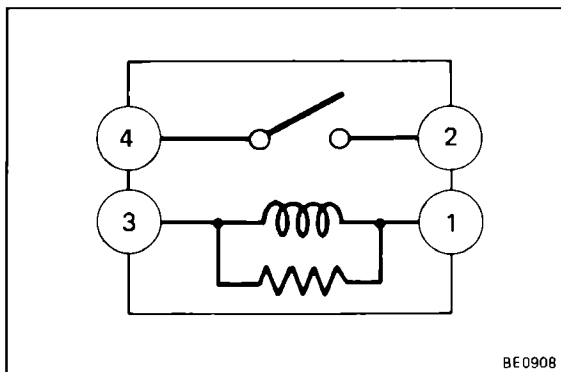

2. INSPECT RELAY OPERATION

- Apply battery voltage across terminals 1 and 3.
- Check that there is continuity between terminals 2 and 4.
- Check that there is no continuity between terminals 3 and 4.

If operation is not as specified, replace the relay.

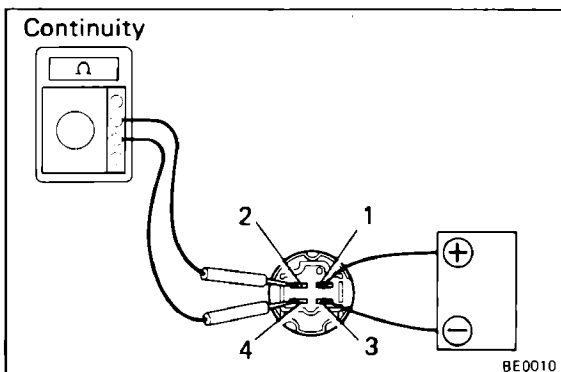

Light Retractor Control Relay

INSPECTION OF LIGHT RETRACTOR CONTROL RELAY

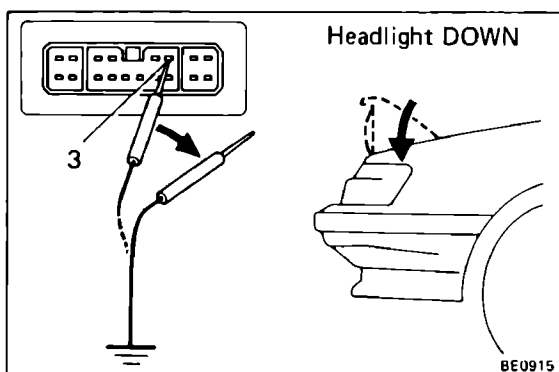
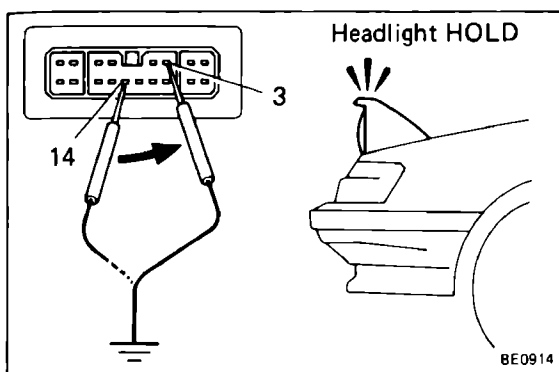
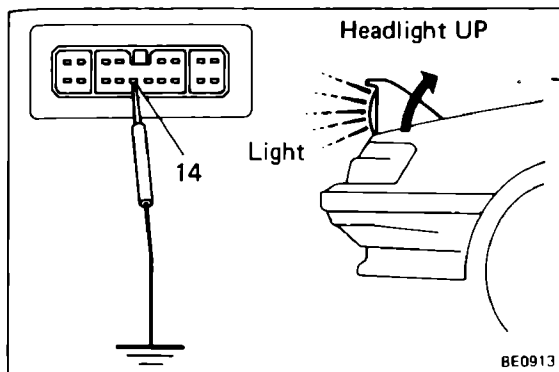

1. INSPECT LIGHT RETRACTOR RELAY OPERATION

- (a) With the light control switch off, connector connected, and terminal 14 grounded, raise the headlights with the lights lit.
- (b) Quickly ground terminal 3. The light will go out, but the headlight should remain up.

- (c) When terminal 3 is taken off ground, the headlights should flip down.

If operation is not as specified, replace the relay.

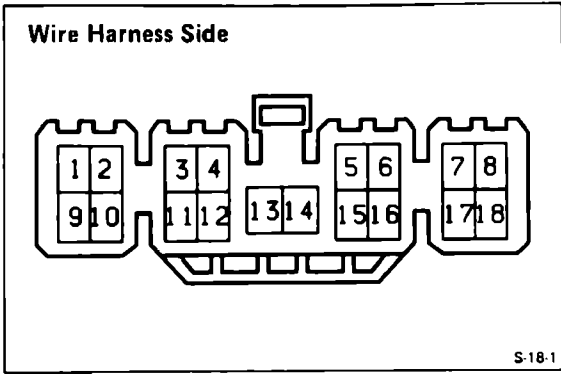

2. INSPECT RELAY CIRCUIT

Disconnect the relay connector and inspect the connector on the wire harness side as shown in the chart.

NOTE: This circuit includes the diode, if the circuit shows no continuity change the positive and negative probes and recheck the circuit.

Check item	Tester connection	Condition	Voltage or resistance
Voltage	8 – Ground	—	Battery voltage
Continuity	18 – Ground	—	Continuity
Voltage	4 – Ground	Ignition switch to LOCK or ACC	No voltage
		Ignition switch ON	Battery voltage
	2 – Ground	—	Battery voltage
	10 – Ground	—	Battery voltage
	15 – Ground	Door courtesy switch OFF (Door close)	Battery voltage
Door courtesy switch ON (Door open)		No voltage	
Continuity	3 – Ground	Light switch to OFF or HEAD	No continuity
		Light switch to HOLD or TAIL	Continuity
	13 – Ground	Light switch to OFF or HOLD	No continuity
		Light switch to TAIL or HEAD	Continuity
	14 – Ground	Light switch to OFF, HOLD or HEAD and dimmer switch Low beam or High beam.	No continuity
		Light switch to HEAD or Dimmer switch Flash	Continuity
	6 – Ground	—	Continuity
	16 – Ground	—	Continuity
	5 – 1	Headlight lowermost position	No continuity
		Headlight any position except lowermost position	Continuity
	7 – 1	Headlight lowermost position	No continuity
		Headlight any position except lowermost position	Continuity
	5 – 9	Headlight uppermost position	No continuity
		Headlight any position except uppermost position	Continuity
	7 – 9	Headlight uppermost position	No continuity
		Headlight any position except uppermost position	Continuity

If circuit is as specified, replace the relay.

Light Retractor Motor

INSPECTION OF LIGHT RETRACTOR MOTOR

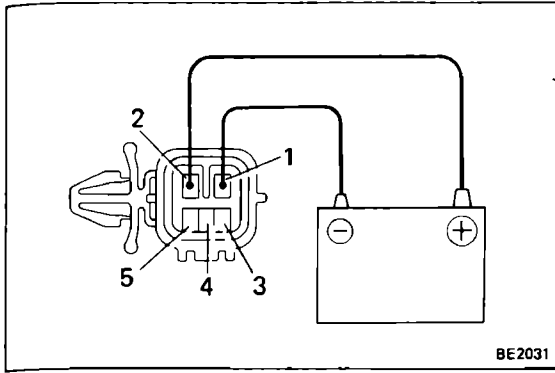

1. INSPECT MOTOR OPERATION

Connect the positive (+) lead from the battery to terminal 2 and connect the negative (-) lead to terminal 1. Check that the motor operates.

If there is no motor operation, replace the motor.

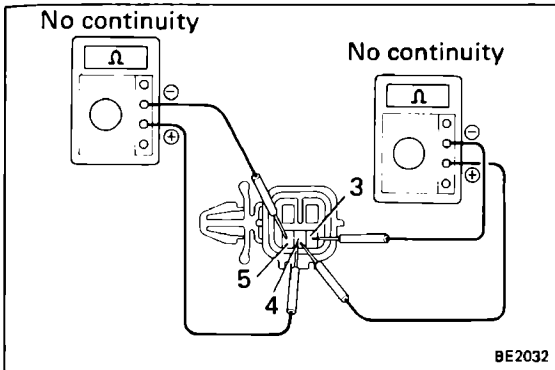

2. INSPECT DIODE CONTINUITY OF MOTOR

(a) Move the headlights to position except the uppermost or lowermost positions.

(b) Connect the ohmmeter positive (+) lead to terminal 4 and the negative (-) lead to terminal 5.

(c) Check that there is no continuity.

(d) Connect the ohmmeter positive (+) lead to terminal 4 and the negative (-) lead to terminal 3.

(e) Check that there is no continuity.

If there is continuity, replace the motor assembly.

(f) Reverse the test leads of the ohmmeter.

(g) Check that there is continuity.

If there is no continuity, replace the motor assembly.

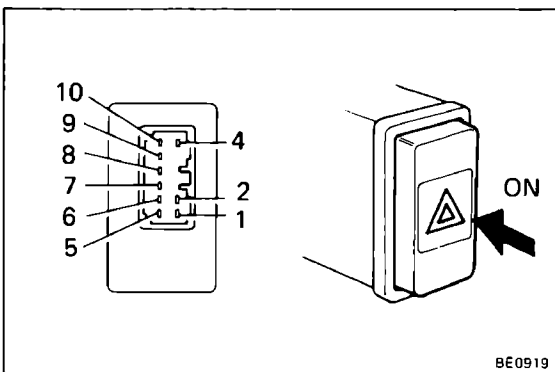
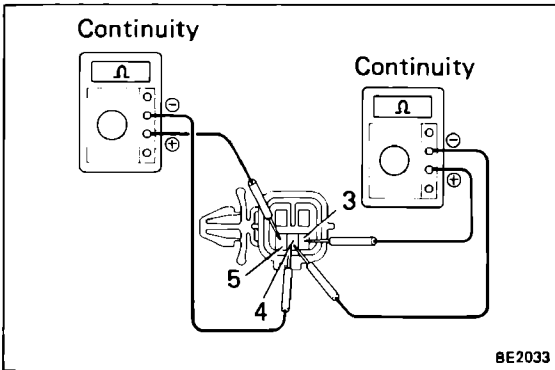

Hazard Warning Switch

INSPECTION OF HAZARD WARNING SWITCH

INSPECT HAZARD WARNING SWITCH CONTINUITY

Inspect the switch continuity between terminals.

Switch position	Terminal								
	9	4	10	2	6	7	8	5	1
OFF (Free)	○	○	○					○	○
ON (Lock)		○	○	○	○	○	○	○	○

If continuity is not as specified, replace the switch or bulb.

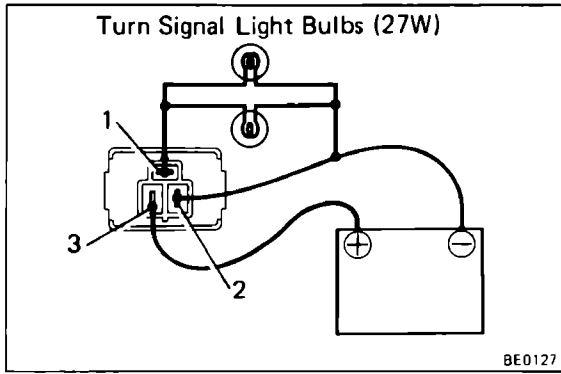

Turn Signal Flasher

INSPECTION OF TURN SIGNAL FLASHER

INSPECT FLASHER OPERATION

- (a) Connect the positive (+) lead from the battery to terminal 3 and the negative (-) lead to terminal 2.
- (b) Connect the two turn signal light bulbs parallel to each other to terminals 1 and 2.

Check that the bulbs turn on and off.

NOTE: The turn signal lights should flash 60 to 120 times per minute.

If one of the front or rear turn signal lights has an open circuit, the number of flashes will be more than 140 per minute.

If operation is not as specified, replace the flasher.

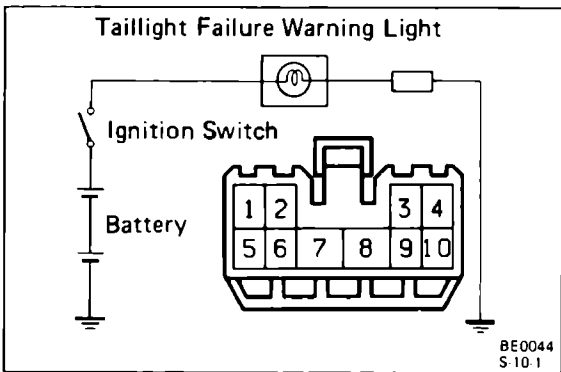

Taillight Failure Sensor

INSPECTION OF TAILLIGHT FAILURE SENSOR

1. INSPECT WARNING LIGHT OPERATION

- (a) Disconnect the connector from the failure sensor. Connect terminal 3 of wire harness side connector and body ground.
- (b) Remove CHARGE fuse and turn the ignition switch on. Check that the bulb lights.

If operation is not correct, remove and test the bulb.

2. INSPECT FAILURE SENSOR CIRCUIT

Disconnect the failure sensor and inspect the connector on the wire harness side as shown in the following chart.

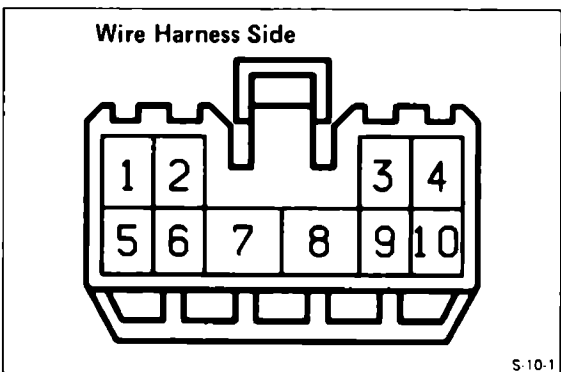

Check for	Tester connection	Condition	Specified value
Continuity	1 – Ground	Always	Continuity
Voltage	2 – Ground	Turn ignition switch to LOCK or ACC	No voltage
		Turn ignition switch ON	Battery voltage
	3 – Ground	Turn ignition switch to LOCK or ACC	No voltage
		Turn ignition switch ON	Remove CHARGE fuse Install CHARGE fuse
Continuity	4 – Ground	Always	Continuity
Voltage	7 – Ground	Stop light switch OFF (Brake pedal released)	No voltage
		Stop light switch ON (Brake pedal depressed)	Battery voltage
Continuity	9 – Ground	Always	Continuity
Voltage	10 – Ground	Turn light control switch to OFF or HOLD	No voltage
		Turn light control switch to TAIL or HEAD	Battery voltage

If circuit is correct as specified above, replace the failure sensor.

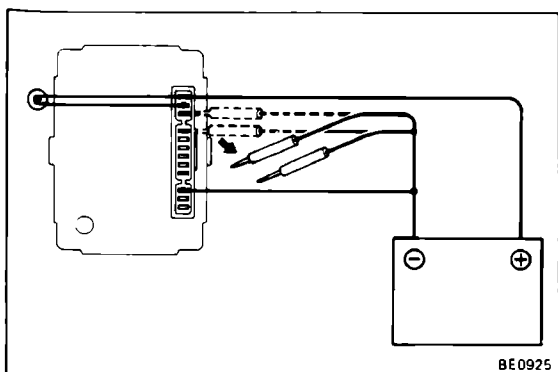
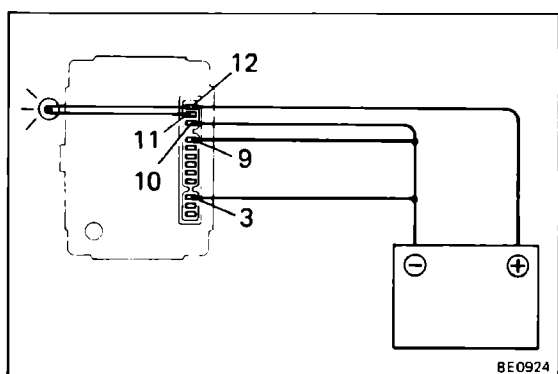

Integration Relay

INSPECTION OF INTEGRATION RELAY

INSPECT RELAY OPERATION (KEY ILLUMINATION)

Connect the positive (+) lead from the battery to terminal 12. Connect the negative (–) lead to terminals 3, 9 and 10. Connect a 3.4W test bulb between terminals 11 and 12.

(a) Check that the bulb lights.

(b) Disconnect the negative (–) lead from terminals 9 and 10, and check that the bulb goes out 5 seconds later.

If operation is not as specified, replace the relay.

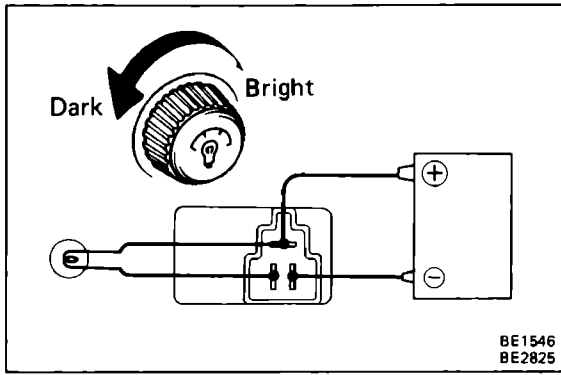

Light Control Rheostat

INSPECTION OF LIGHT CONTROL RHEOSTAT

INSPECT RHEOSTAT OPERATION

- (a) Connect the positive (+) lead from the battery to terminal 1 and the negative (-) lead to terminal 2.
- (b) Connect the terminals 1 and 3 through a 3.4 W test bulb.
- (c) Gradually turn the rheostat knob from the bright side to dark side, check that the test bulb brightness changes from bright to dark.

If operation is not as specified, replace the rheostat.

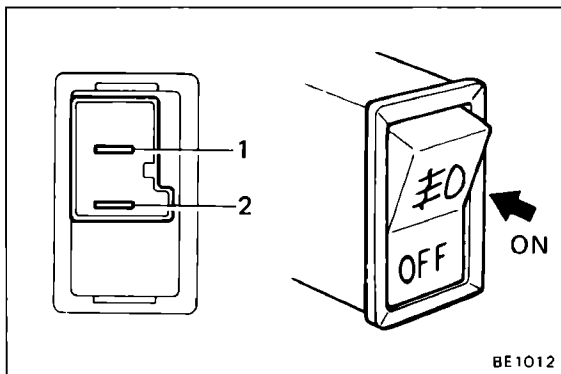

Fog Light Switch

INSPECT SWITCH CONTINUITY

Inspect the switch continuity between terminals.

Terminals	1	2
Position		
ON	○ — ○	
OFF		

If continuity is not as specified, replace the switch.

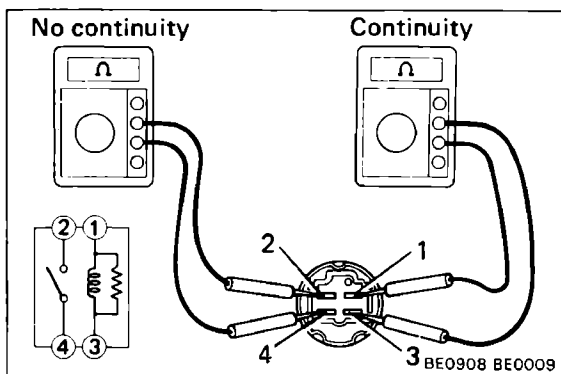

Fog Light Relay

1. INSPECT RELAY CONTINUITY

- (a) Check that there is continuity between terminals 1 and 3.
- (b) Check that there is no continuity between terminals 2 and 4.
- (c) Check that there is no continuity between terminals 3 and 4.

If continuity is not as specified, replace the relay.

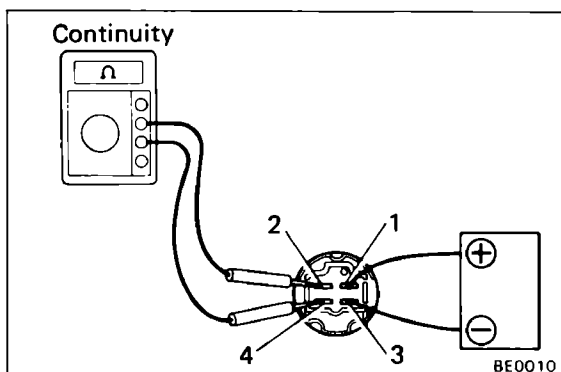

2. INSPECT RELAY OPERATION

- (a) Apply battery voltage to terminals 1 and 3.
- (b) Check that there is continuity between terminals 2 and 4.
- (c) Check that there is no continuity between terminals 3 and 4.

If operation is not as specified, replace the relay.

WIPERS AND WASHERS

Troubleshooting

Problem	Possible cause	Remedy	Page	
			Front	Rear
Wipers do not operate or return to off position	WIPER fuse blown	Replace fuse and check for short	BE-4	BE-4
	Wiper motor faulty	Check motor	BE-27	BE-28
	Wiper switch faulty	Check switch	BE-25	BE-28
	Wiring or ground faulty	Repair as necessary		
Wipers do not operate in INT position	Wiper relay faulty	Check relay		BE-28
	Wiper switch faulty	Check switch	BE-25	BE-28
	Wiper motor faulty	Check motor	BE-27	BE-28
	Wiring or ground faulty	Repair as necessary		
Washers do not operate	Washer hose or nozzle clogged	Repair as necessary		
	Washer motor faulty	Replace motor		
	Washer switch faulty	Check switch	BE-25	BE-28
	Wiring faulty	Repair as necessary		

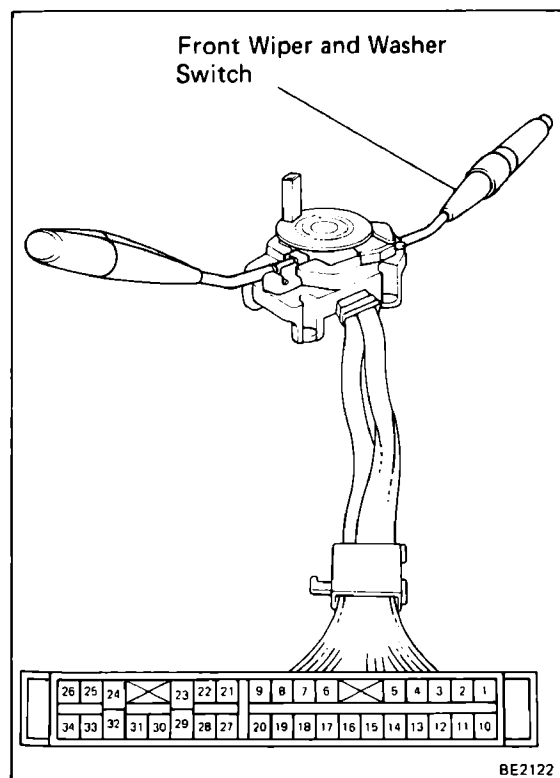

Front Wiper and Washer Switch

INSPECTION OF FRONT WIPER AND WASHER SWITCH

1. INSPECT FRONT WIPER AND WASHER SWITCH CONTINUITY

Inspect the switch continuity between terminals.

Switch	Switch position	Terminal (Wire color)					
		18 +B (L-W)	13 +2 (L-O)	7 +1 (L-B)	4 +S (L-R)	16 Ew (B)	8 W (L)
Wiper	OFF			○—○			
	INT			○—○			
	LO	○—○		○			
	HI	○—○					
Washer	OFF						
	ON						○—○

If continuity is not as specified, replace the switch.

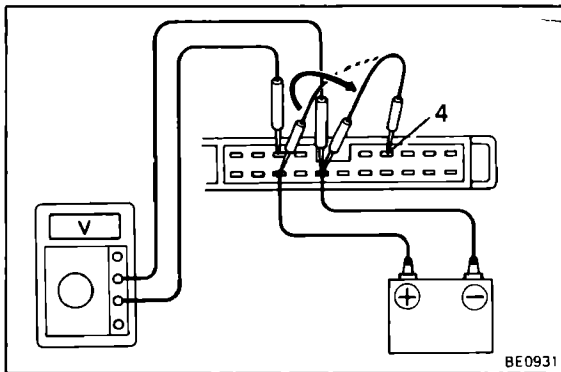
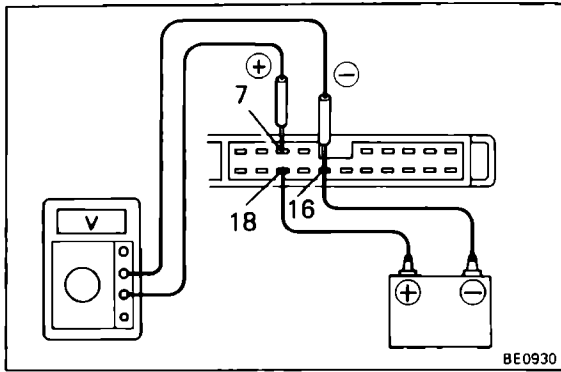

2. INSPECT INTERMITTENT OPERATION OF SWITCH

- (a) Turn the wiper switch to INT position.
- (b) Turn the INT switch to FAST position. (Variable type)
- (c) Connect the positive (+) lead from the battery to terminal 18 and the negative (-) lead to terminal 16.
- (d) Connect the positive (+) lead from the voltmeter to terminal 7 and the negative (-) lead to terminal 16. Check that the meter needle indicates battery voltage.
- (e) After connecting terminal 4 to terminal 18, connect it to terminal 16.

Then, check that the voltage rises from 0 volts to battery voltage with in the times as shown in the table.

INT time control switch position	Voltage
FAST	Approx. 1.6 sec. Battery voltage 0 volt
SLOW	10.7 ± 5 sec. Battery voltage 0 volt
Non variable type	3.3 ± 1 sec. Battery voltage 0 volt

If operations are not as specified, replace the wiper and washer switch.

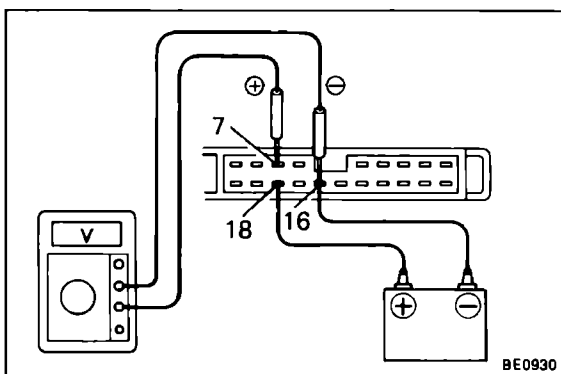

3. INSPECT WASHER SWITCH OPERATION

- (a) Connect the positive (+) lead from the battery to terminal 18 and the negative (-) lead to terminal 16.
- (b) Connect the positive (+) lead from the voltmeter to terminal 7 and the negative (-) lead to terminal 16.
- (c) Push in the washer switch. Check that the voltage changes as shown in the table.

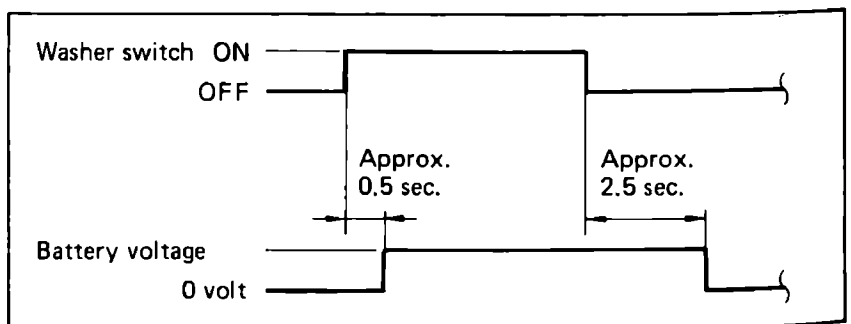

If operation is not as specified, replace the wiper and washer switch.

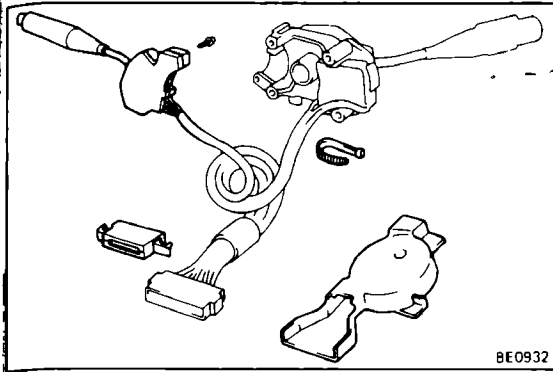

REPLACEMENT OF WIPER AND WASHER SWITCH

REPLACE WIPER AND WASHER SWITCH

- (a) Remove the terminals from the connector. (See pages BE-2, 3)
- (b) Remove the wiper and washer switch.
- (c) Install the wiper and washer switch.
- (d) Install the terminals to the connector. (See pages BE-3, 25)

Front Wiper Motor

INSPECTION OF FRONT WIPER MOTOR

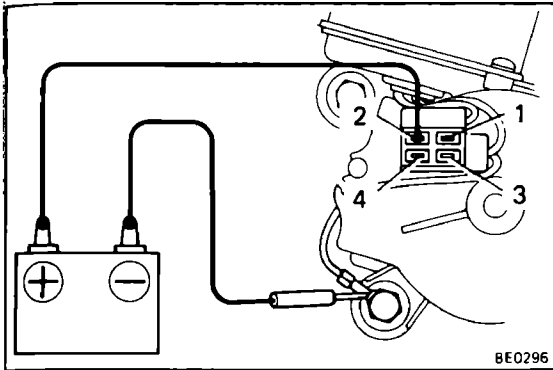

1. INSPECT THAT MOTOR OPERATES AT LOW SPEED

- (a) Disconnect the connector from the wiper motor.
- (b) Connect the positive (+) lead from the battery to terminal 2. Connect the negative (-) lead to the motor body.
- (c) Check that the motor operates at low speed. If operation is not as specified, replace the motor.

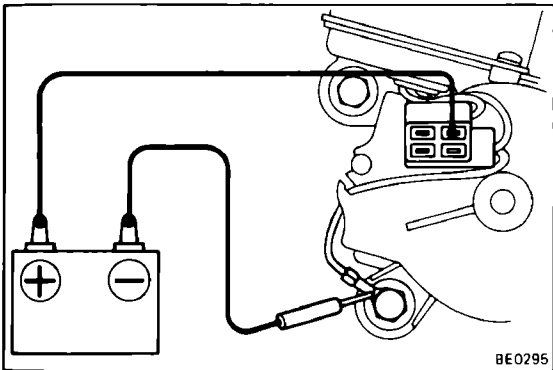

2. INSPECT THAT MOTOR OPERATES AT HIGH SPEED

- (a) Connect the positive (+) lead from the battery to terminal 1. Connect the negative (-) lead to the motor body.
- (b) Check that the motor operates at high speed. If operation is not as specified, replace the motor.

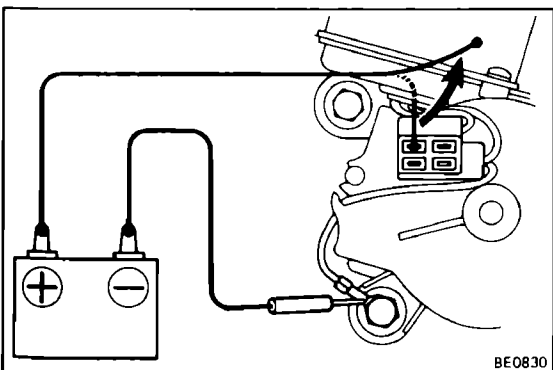

3. INSPECT THAT MOTOR OPERATES, STOPPING AT STOP POSITION

- (a) Operate the motor at low speed.
- (b) Stop motor operation anywhere except at the off position by disconnecting terminal 2.

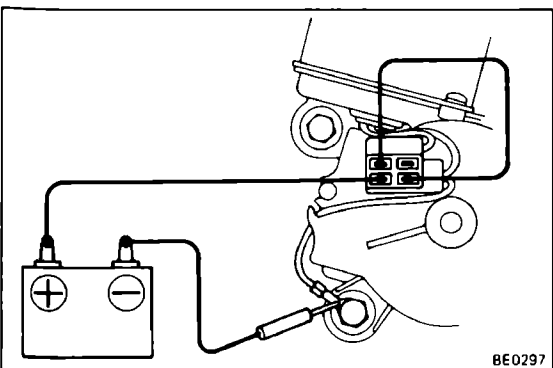

- (c) Connect terminals 2 and 3.
- (d) Connect the positive (+) lead from the battery to terminal 4.
- (e) Check that the motor stops running at the off position after the motor operates again.

If operation is not as specified, replace the motor.

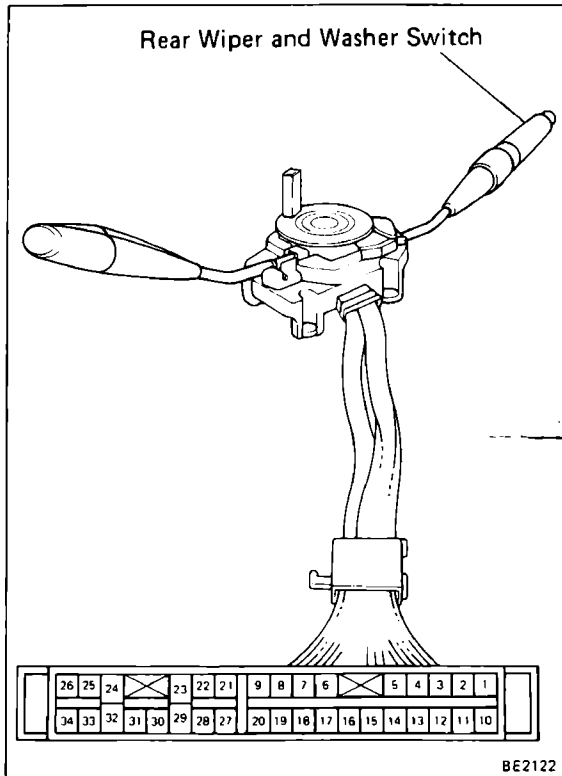

Rear Wiper and Washer Switch

INSPECTION OF REAR WIPER AND WASHER SWITCH

INSPECT SWITCH CONTINUITY

Inspect the switch continuity between terminals.

Terminal (Wire color)	16 Ew (B)	2 WR (V)	10 C ₁ R (O)	1 +1R (GR)
Washer I	○ — ○			
OFF				
INT	○ — ○		○	
ON	○ — ○		○ — ○	○
Washer II	○ — ○	○ — ○	○ — ○	○

If continuity is not as specified, replace the switch.

REPLACEMENT OF REAR WIPER AND WASHER SWITCH

(See Front Wiper and Washer Switch on page BE-25)

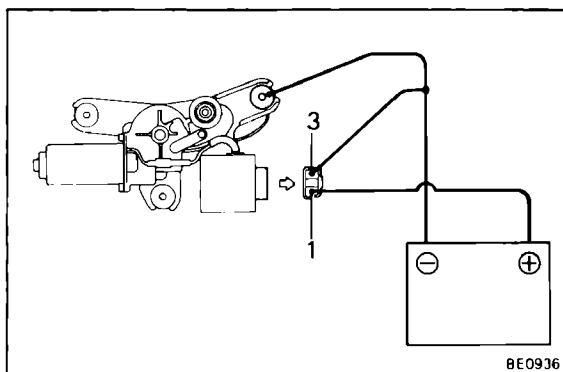

Rear Wiper Motor and Relay

INSPECTION OF REAR WIPER MOTOR AND RELAY

1. INSPECT RELAY AND MOTOR OPERATES

Check that the motor operates after connecting the positive (+) battery lead to terminal 1 and the negative (-) battery lead to both terminal 3 and motor body.

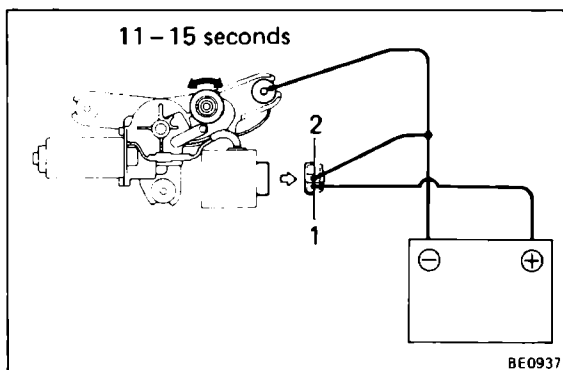

2. INSPECT INTERMITTENT OPERATION OF RELAY

Check that the motor operates intermittently for 10 – 15 seconds after connecting the positive (+) battery lead to terminal 1 and the negative (-) battery lead to both terminal 2 and motor body.

If operation is not as specified, replace the relay.

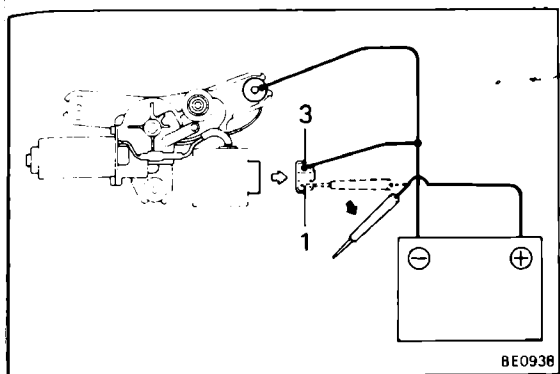

3. INSPECT THAT MOTOR OPERATES, STOPPING AT STOP POSITION

- (a) Start motor operation by connecting the positive (+) battery lead to terminal 1 and the negative (–) battery lead to both terminal 3 and motor body.
- (b) Stop motor operation anywhere except stop position by disconnecting terminal 1.

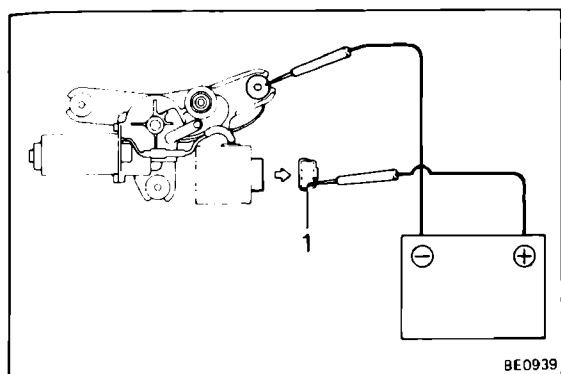

- (c) Connect the positive (+) lead from the battery to terminal 1. Connect the negative (–) lead to the motor body.
- (d) Check that the motor stops running at the off position after the motor operates again.

If operation is not as specified, replace the motor.

INSTRUMENTS, GAUGES AND WARNING LIGHTS

Troubleshooting

Problem	Possible cause	Remedy	Page
Tachometer does not work	"GAUGE" fuse blown Tachometer faulty Wiring or ground faulty	Replace fuse and check for short Check tachometer Repair as necessary	BE-4 BE-32, 57
Fuel gauge does not work	"GAUGE" fuse blown Fuel gauge faulty Sender gauge faulty Wiring or ground faulty	Replace fuse and check for short Check gauge Check sender gauge Repair as necessary	BE-4 BE-33, 58 BE-34, 58
Water temperature gauge does not work	"GAUGE" fuse blown Water temperature gauge faulty Sender gauge faulty Wiring or ground faulty	Replace fuse and check for short Check gauge Check sender gauge Repair as necessary	BE-4 BE-35, 58 BE-35, 59
Oil pressure gauge does not work	"GAUGE" fuse blown Oil pressure gauge faulty Sender gauge faulty Wiring or ground faulty	Replace fuse and check for short Check gauge Check sender gauge Repair as necessary	BE-4 BE-36 BE-36
Low oil pressure light does not light	"GAUGE" fuse blown Bulb burned out Oil pressure switch faulty Wiring or ground faulty	Replace fuse and check for short Replace bulb Check switch Repair as necessary	BE-4 BE-59 BE-59
Brake warning light and indicator light does not light	"GAUGE" fuse blown Bulb burned out Brake fluid level warning switch faulty Parking brake switch faulty Wiring or ground faulty	Replace fuse and check for short Replace bulb Check switch Check switch Repair as necessary	BE-4 BE-36, 60 BE-37, 60

Combination Meter and Gauge

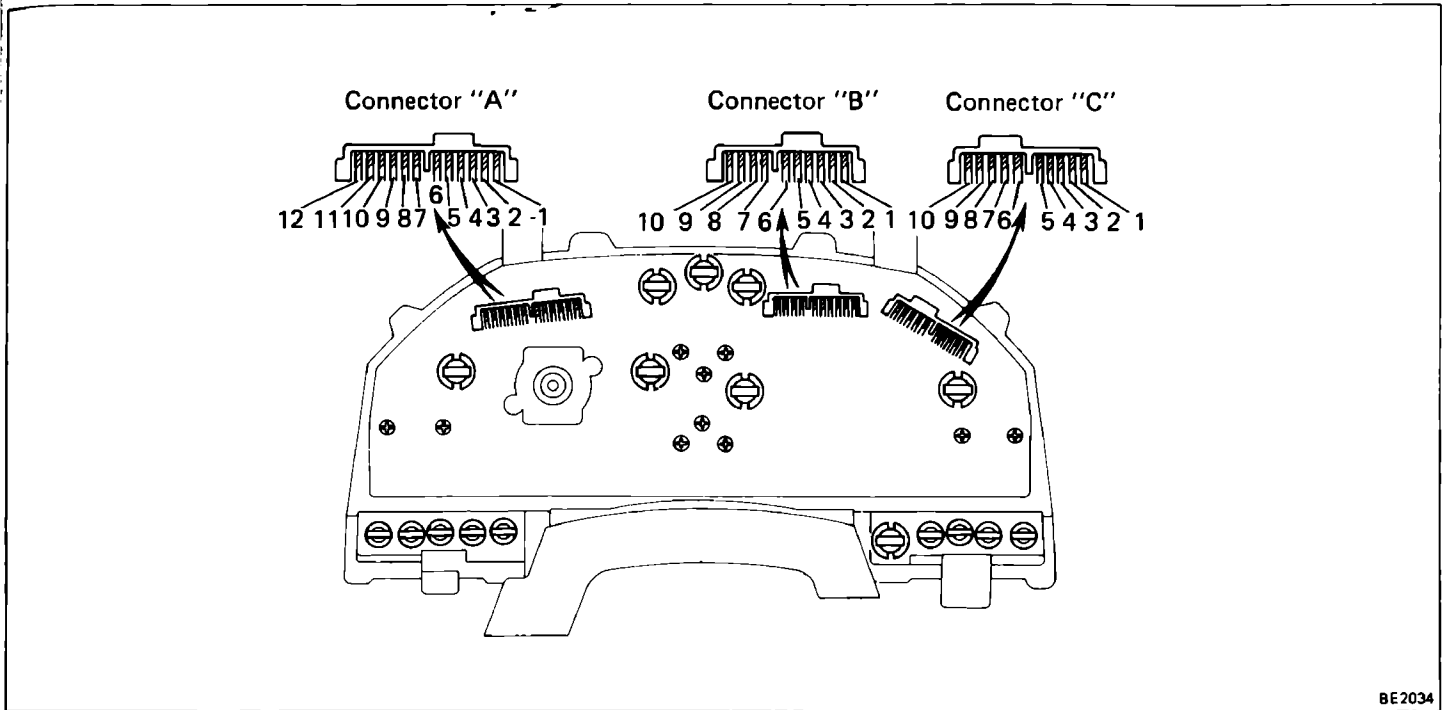

BE2034

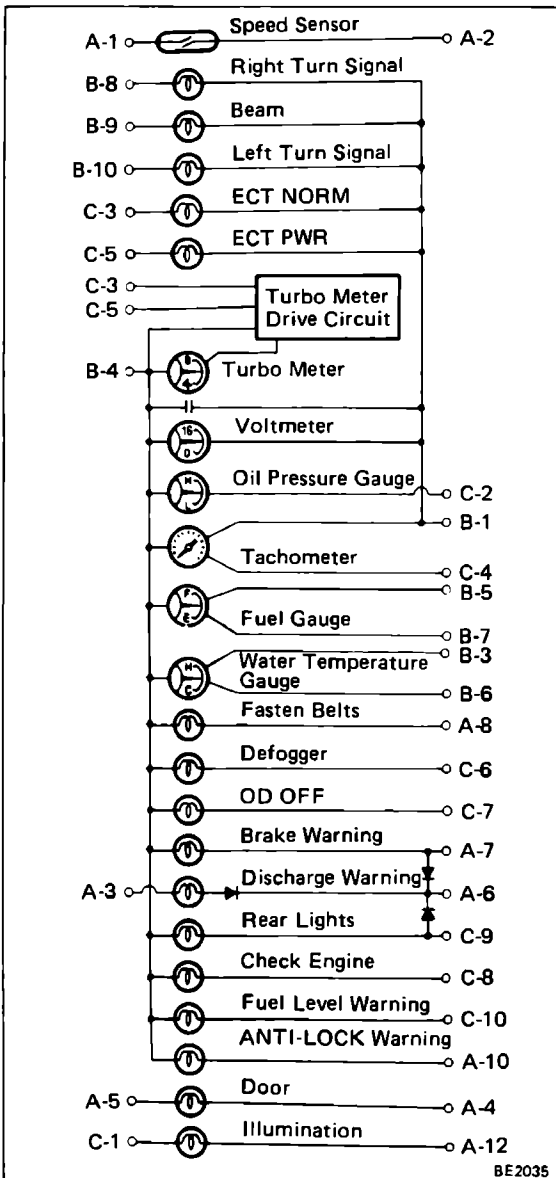

BE2035

COMBINATION METER CIRCUIT

No.	Wiring connector side	
A	1 TCCS ECU, Cruise Control ECU and ECT ECU	
	2 Ground	
	3 IGN Fuse	
	4 Door Courtesy Switch	
	5 DOME Fuse	
	6 CHARGE Fuse	
	7 Parking Brake Switch and Brake Fluid Level Warning Switch	
	8 Seat Belt Warning Relay	
	10 A.B.S. Computer	
	12 Light Control Rheostat	
	B	1 Ground
		3 Water Temperature Gauge
4 GAUGE Fuse		
5 Ground		
6 Ground		
7 Fuel Sender Gauge		
8 Turn Signal Switch		
9 Headlight Dimmer Switch		
10 Turn Signal Switch		
C		1 TAIL Fuse
	2 Oil Pressure Sender Gauge	
	3 ECT Select Switch NORM (w/ 3S-GTE) Turbo Pressure Sensor	
	4 IIA or Ignition Coil	
	5 ECT Select Switch PWR (w/ 3S-GTE) Turbo Pressure Sensor (Ground)	
	6 Rear Window Defogger Switch	
	7 OD Main Switch	
	8 TCCS ECU	
	9 Light Failure Sensor	
	10 Fuel Sender Gauge	

Speedometer

ON-VEHICLE INSPECTION OF SPEEDOMETER

- (a) Using a speedometer tester, inspect the speedometer for allowable indication error and check the operation of the odometer.

NOTE: Tire wear and tire over or under inflation will increase the indication error.

Standard indication (km/h)	Allowable range (km/h)
20	18 – 23
40	40 – 44
60	60 – 64.5
80	80 – 85
100	100 – 105
120	120 – 125.5
140	140 – 146
160	160 – 167

Standard indication (mph)	Allowable range
20	20 – 23
40	40 – 43.5
60	60 – 64
80	80 – 84.5
100	100 – 105
120	120 – 125.5

If error is excessive, replace the speedometer.

- (b) Check the speedometer for pointer vibration and abnormal noises.

NOTE: Pointer vibration can be caused by a loose speedometer cable.

Tachometer

ON-VEHICLE INSPECTION OF TACHOMETER

- (a) Connect a tune-up test tachometer, and start the engine.

CAUTION:

- Reversing the connection of the tachometer will damage the transistors and diodes inside.
- When removing or installing the tachometer, be careful not to drop or subject it to heavy shocks.

- (b) Compare the tester and tachometer indications.

Temp. and volts	rpm	700	3,000	5,000	7,000
	25° C	3S-GE	+20	±200	±200
3S-GTE		-120	±200	±200	±300
DC 13.5V	3S-FE	+20	±200	±200	±300
		-120	±200	±200	±300

If error is excessive, replace the tachometer.

Voltmeter

INSPECTION OF VOLTMETER

INSPECT VOLTMETER

Compare the tester and voltmeter indications.
If error is excessive, replace the voltmeter.

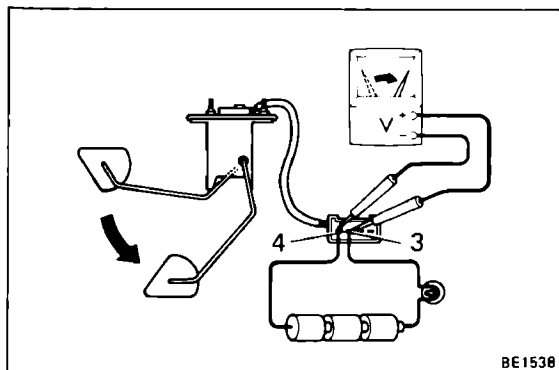
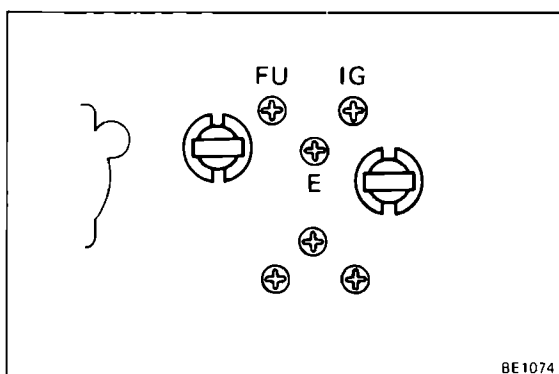
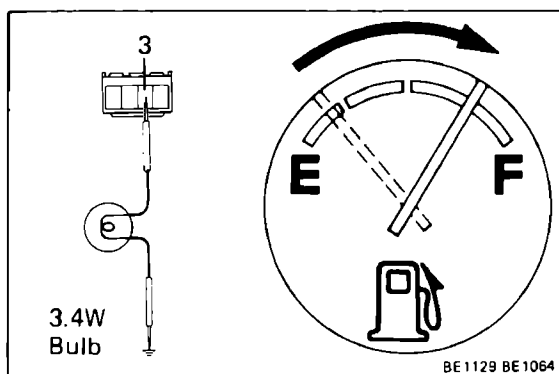
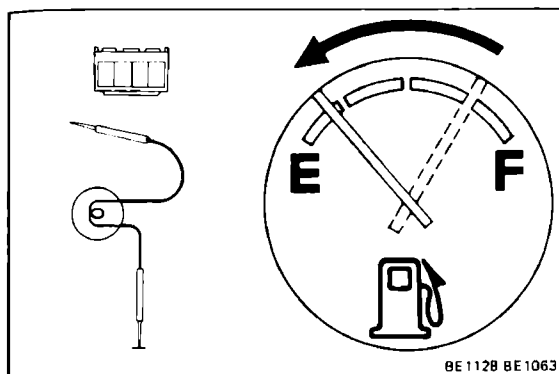

Fuel Gauge

INSPECTION OF FUEL GAUGE

1. INSPECT RECEIVER GAUGE OPERATION

(a) Disconnect the connector from the fuel sender gauge. Turn the ignition switch on. Check that the receiver gauge needle moves to the empty position.

(b) Connect a 3.4W bulb between terminal 3 and body ground. Check that the bulb lights and that the receiver gauge needle operates.

NOTE: Because of the silicon oil in the gauge, it will take about 90 seconds for the needle to stabilize.

If indications are not correct, remove and test the receiver gauge.

2. MEASURE RECEIVER GAUGE RESISTANCE BETWEEN TERMINALS

Measure the resistance between terminals.

Between terminals	Resistance (Ω)
IG – FU	Approx. 101.9
FU – E	Approx. 101.3
IG – E	Approx. 203.2

If each resistance value is not as shown in the table above, replace the receiver gauge.

3. INSPECT SENDER GAUGE OPERATION

- Connect a series of three 1.5V dry cell batteries.
- Connect the positive (+) lead from the dry cell batteries to terminal 3 through a 3.4W test bulb and the negative (-) lead to terminal 4.
- Check that the voltage rises between terminals 3 and 4 as the float is moved from the top to bottom position.

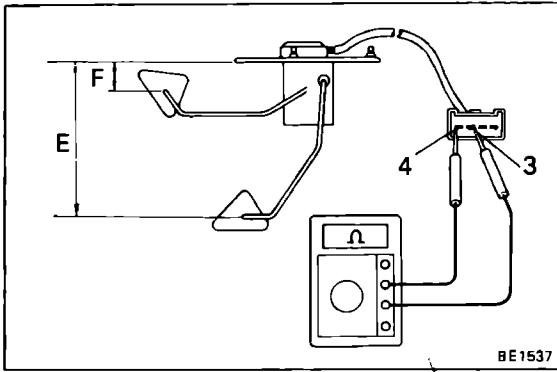

(d) Measure the resistance between terminals 3 and 4 for each float position.

	Float position	mm (in.)	Resistance (Ω)
F	Ex. 3S-GTE	Approx. 76 (2.99)	Approx. 4
	3S-GTE	Approx. 70 (2.76)	Approx. 3
E	Ex. 3S-GTE	Approx. 186 (7.32)	Approx. 110
	3S-GTE	Approx. 234 (9.21)	Approx. 110

If each resistance value is not as shown in the table above, replace the sender gauge.

Fuel Level Warning

INSPECTION OF FUEL LEVEL WARNING

1. INSPECT WARNING LIGHT OPERATION

- Disconnect the connector from the fuel level warning switch. Connect terminal 2 of wire harness side connector and body ground.
- Turn the ignition switch. Check that the bulb lights. If operation is not correct, remove and test the bulb.

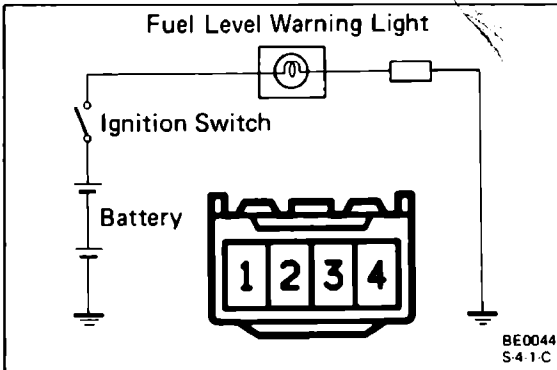

2. INSPECT LEVEL WARNING SWITCH OPERATION

- Apply battery voltage between terminals 1 and 2 through a 3.4W bulb. Check that the bulb lights.

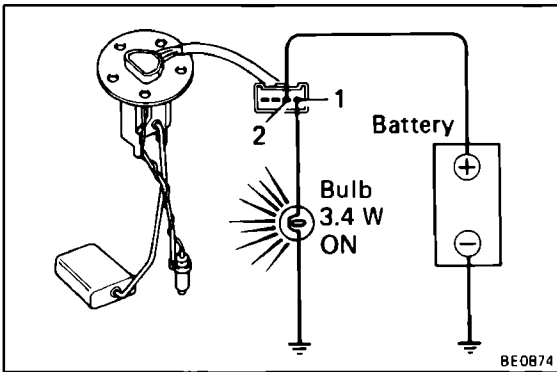

- Submerge the switch in gasoline. Check that the bulb goes out.

If operation is not correct, replace the sender gauge.

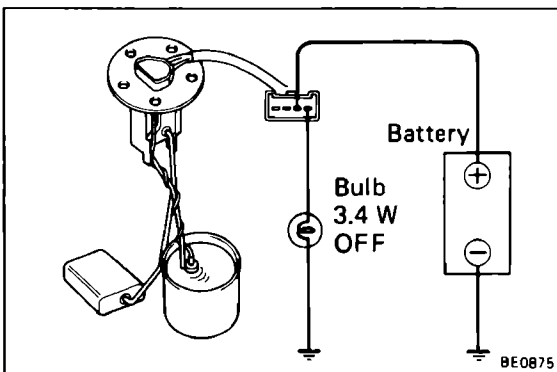

Water Temperature Gauge

INSPECTION OF WATER TEMPERATURE GAUGE

1. INSPECT RECEIVER GAUGE OPERATION

- Disconnect the connector from the sender gauge. Turn the ignition switch on. Check that the receiver gauge needle moves to the cold position.

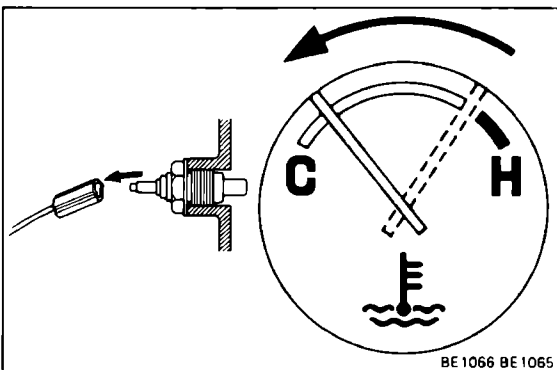

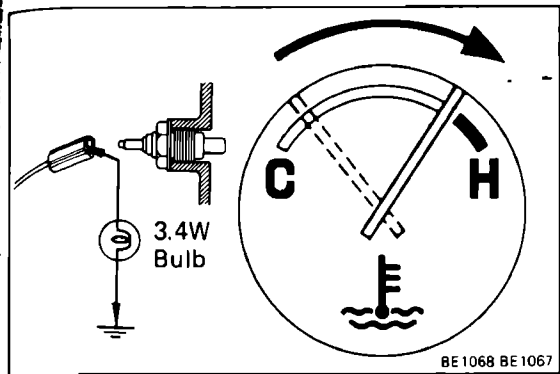

(b) Ground the terminal through a 3.4W bulb as shown. Turn the ignition switch on. Check that the bulb lights and that the receiver gauge needle operates. If indications are not correct, remove and test the receiver gauge.

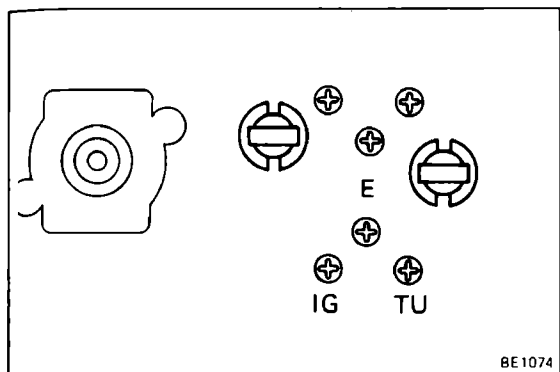

2. MEASURE RECEIVER GAUGE RESISTANCE BETWEEN TERMINALS

Measure the resistance between terminals. If each resistance value is not as shown in the table below, replace the receiver gauge.

Between terminals	Resistance (Ω)
IG – TU	Approx. 56
TU – E	Approx. 201.8
IG – E	Approx. 145.8

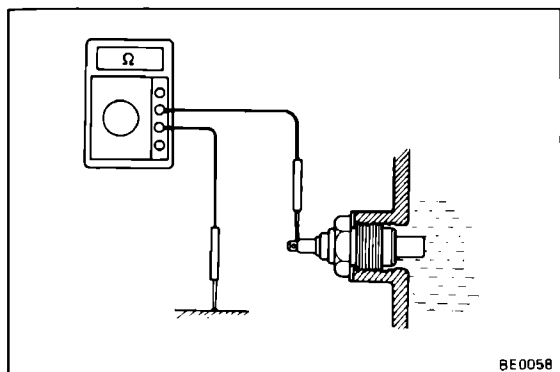

3. MEASURE SENDER GAUGE RESISTANCE

Measure the resistance between terminal and body ground. If each resistance value is not as shown in the table below, replace the sender gauge.

Water temperature $^{\circ}\text{C}$ ($^{\circ}\text{F}$)	Resistance (Ω)	
	Yazaki	Nippondenso
50 (122)	–	$226^{+33.6}_{-36.6}$
60 (140)	152.7	–
115 (239)	$26.4^{+2.2}_{-2.6}$	$26.4^{+1.71}_{-2.21}$

Oil Pressure Gauge

INSPECTION OF OIL PRESSURE GAUGE

1. INSPECT RECEIVER GAUGE OPERATION

(a) Disconnect the connector from the sender gauge. Turn the ignition switch on. Check that the receiver gauge needle moves to the low position.

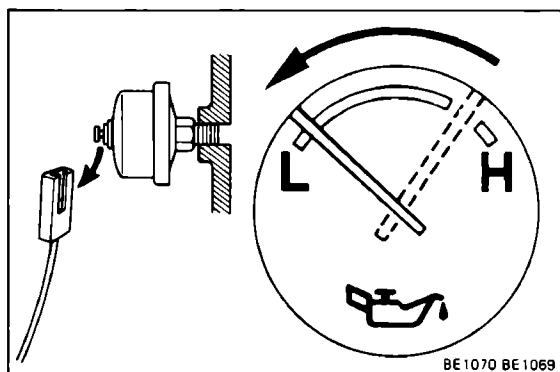

(b) Connect a 3.4W bulb between terminal and body ground. Check that the bulb lights and that the receiver gauge needle operates.

If indications are not correct, remove and test the receiver gauge.

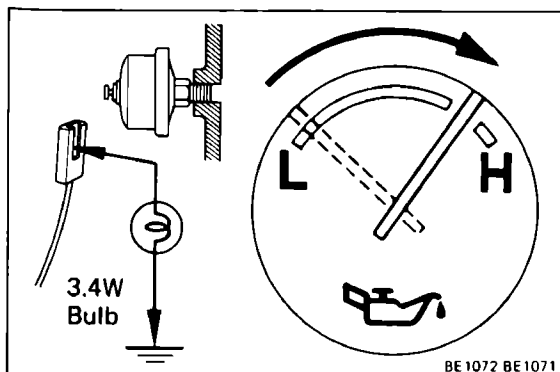

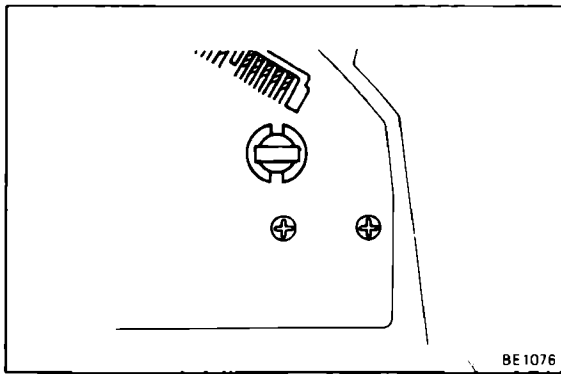

2. MEASURE RECEIVER GAUGE RESISTANCE BETWEEN TERMINALS

Measure the resistance between terminals.

Resistance: Approx. 42 Ω

If resistance value is not correct, replace the receiver gauge.

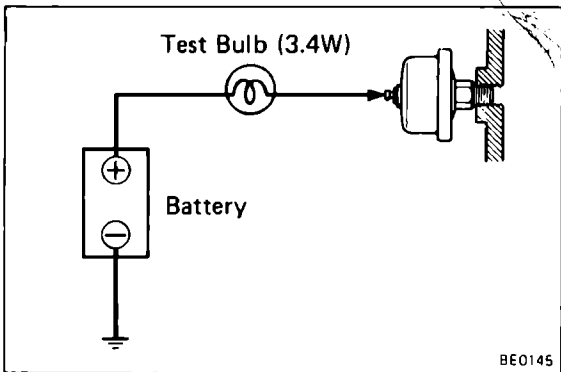

3. INSPECT SENDER GAUGE OPERATION

(a) Disconnect the connector from the sender gauge.

(b) Connect a 12V battery to the sender gauge terminal in series with a 3.4W bulb. Check that the bulb does not light when the engine is stopped, and flashes when the engine is running.

The number of flashes should vary with engine speed.

If operation is not correct, replace the sender gauge.

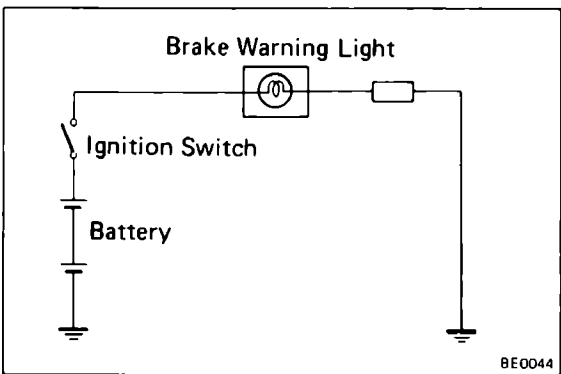

Brake Warning

INSPECTION OF BRAKE WARNING

1. INSPECT WARNING LIGHT OPERATION

(a) Disconnect the connectors from the level warning switch and parking brake switch.

(b) Connect the terminals on the wire harness side of the level warning switch connector.

(c) Remove the CHARGE fuse and turn the ignition switch ON.

Check that the warning light lights.

If the warning light does not light, test the bulb.

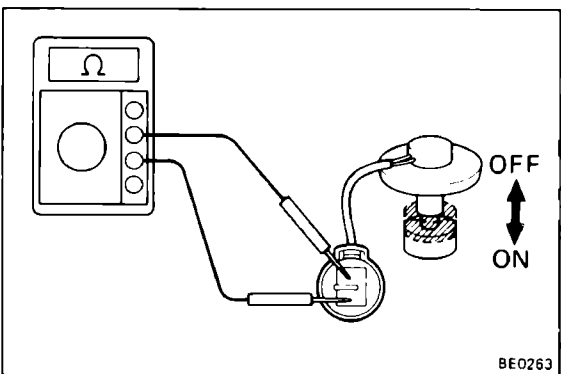

2. INSPECT LEVEL WARNING SWITCH OPERATION

(a) Check that there is no continuity between terminals with the switch OFF (float up).

(b) Check that there is continuity between terminals with the switch ON (float down).

If operation is not as specified, replace the switch.

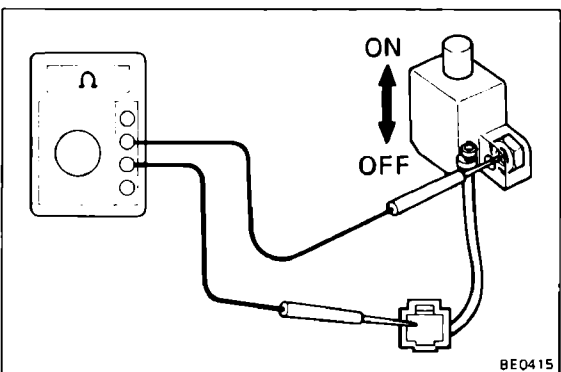

3. INSPECT PARKING BRAKE SWITCH OPERATION

(a) Check that there is continuity between terminal and switch set nut with the switch pin released (parking brake lever pulled up).

(b) Check that there is no continuity between terminal and switch set nut with the switch pin pushed in (parking brake lever released).

If operation is not as specified, replace the switch.

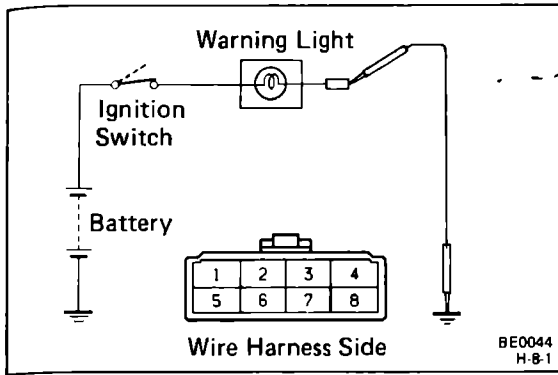

Fasten Belt Warning

INSPECTION OF BELT WARNING

1. INSPECT WARNING LIGHT OPERATION

- (a) Disconnect the connector from the integration relay and ground terminal 4 on the wire harness side.
- (b) Turn the ignition switch ON, check that the warning light lights.

If warning light does not light, test the bulb.

2. INSPECT BUCKLE SWITCH CONTINUITY

- (a) Disconnect the connector from the switch.
- (b) Check that there is continuity between terminals on the switch side connector with the belt fastened.
- (c) Check that there is no continuity between terminals on the switch side connector with the belt unfastened.

If operation is not as specified, replace the seat belt inner.

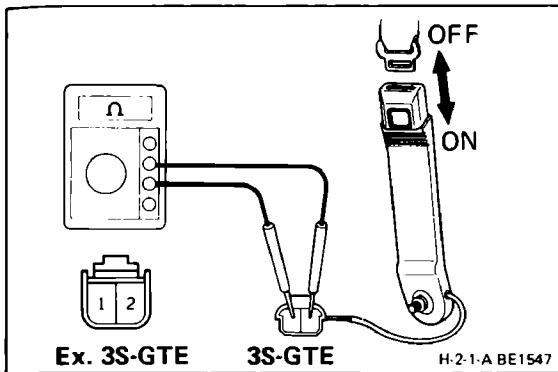

3. INSPECT INTEGRATION RELAY CIRCUIT (FASTEN BELT WARNING)

Disconnect the integration relay and inspect the connector on the wire harness side as shown in the following chart.

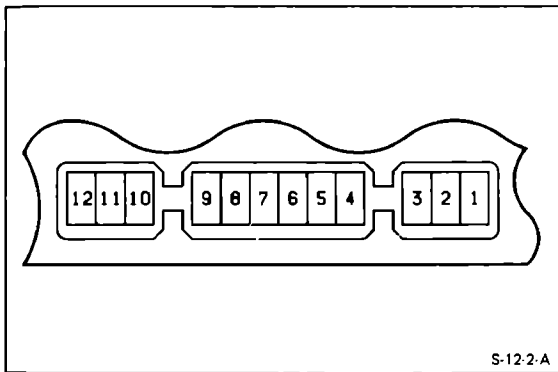

Check for	Tester connection	Condition	Specified value
Continuity	3 – Ground	Always	Continuity
Voltage	4 – Ground	Turn ignition switch to LOCK or ACC	No voltage
		Turn ignition switch ON	Battery voltage
Continuity	5 – Ground	Buckle switch OFF (seat belt unfastened)	No continuity
		Buckle switch ON (seat belt fastened)	Continuity
Voltage	6 – Ground	Turn ignition switch to LOCK or ACC	No voltage
		Turn ignition switch ON	Battery voltage
Voltage	12 – Ground	Always	Battery voltage

If circuit is as specified, replace the relay.

Turbo Meter

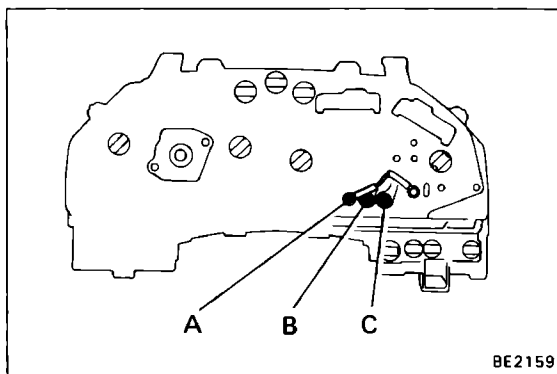
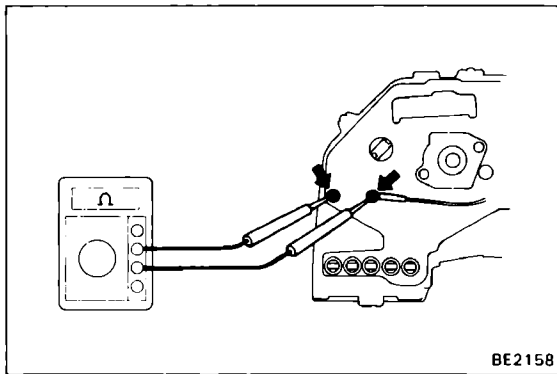
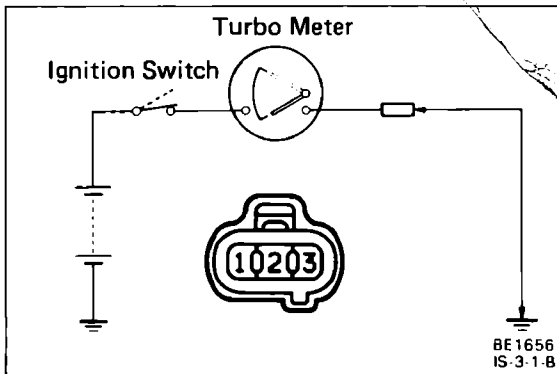
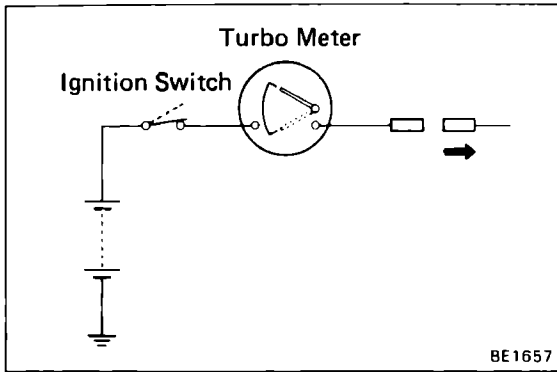

1. INSPECT METER OPERATION

- (a) Disconnect the connector from the pressure sensor.
- (b) Turn the ignition switch ON. Check that the meter needle moves to upper position.

- (c) Ground terminal 2 on the wire harness side. Check that the meter needle moves to lower position.

If operation is not as specified, inspect the turbo meter circuit and resistance.

2. MEASURE METER RESISTANCE

Measure the resistance between terminals.

Resistance: Approx. 72 Ω

If resistance value is not as specified, replace the turbo meter.

3. INSPECT METER DRIVE CIRCUIT

- (a) Remove the combination meter with connected the wire harness.
- (b) Inspect terminals of the meter drive circuit as shown in the chart.

Check for	Tester connection	Condition	Specification value
Continuity	B — Ground	Always	Continuity
Voltage	A — Ground	Turn ignition switch to ACC or LOCK	No voltage
		Turn ignition switch ON	Battery voltage
	C — Ground	Turn ignition switch to ACC or LOCK	No voltage
		Turn ignition switch ON	Approx. 2.6 V
		Engine idling	Less than Approx. 2.0 V

If operation is as specified, replace the drive circuit.

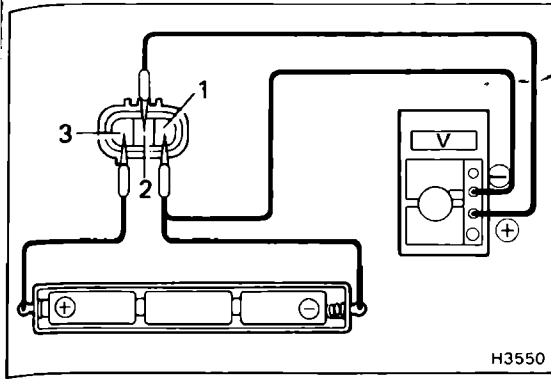

4. INSPECT PRESSURE SENSOR

- (a) Connect a series of three 1.5 V dry cell batteries.
- (b) Connect the positive (+) lead from the dry cell batteries to terminal 3 and the negative (-) lead to terminal 1.
- (c) Connect the positive (+) lead from the voltmeter to terminal 2 and the negative (-) lead to terminal 1.
- (d) Check that the voltage between terminals 2 and 1.

Voltage: Approx. 2.6 V

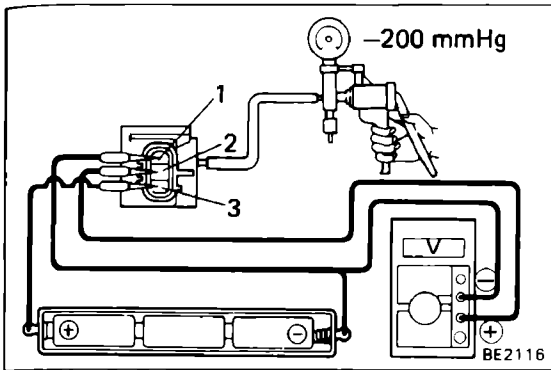

- (e) Apply 200 mmHg (7.87 in.Hg. 26.7 kPa) of vacuum. Check that the voltage drops below approximately 2.6 V.

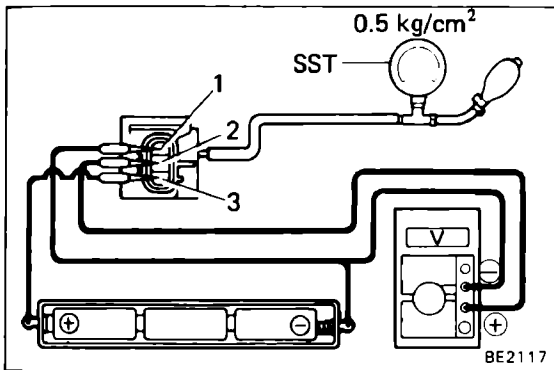

- (f) Using SST, apply 0.5 kg/cm² (7.1 psi, 49 kPa) of pressure.

Check that the voltage rises approximately 2.6 V.

SST 09992-00241

If operations are not as specified, replace the sensor.

REAR WINDOW DEFOGGER

Troubleshooting

Problem	Possible cause	Remedy	Page
Rear window defogger does not work	Circuit breaker OFF	Reset breaker and check for short	BE-4
	GAUGE fuse blown	Replace fuse and check for short	BE-4
	Defogger switch faulty	Check switch	BE-40
	Defogger relay faulty	Check relay	BE-40
	Defogger wire broken	Check wires	BE-41
	Wiring and ground faulty	Repair as necessary	

Rear Window Defogger Switch

INSPECTION OF DEFOGGER SWITCH (w/o Timer)

INSPECT SWITCH CONTINUITY

Inspect the switch continuity between terminals.

Terminal Switch position	5	6	1	3
OFF (Free)			○—○	○—○
ON (Lock)	○—○	○—○	○—○	○—○

If continuity is not as specified, replace the switch or bulb.

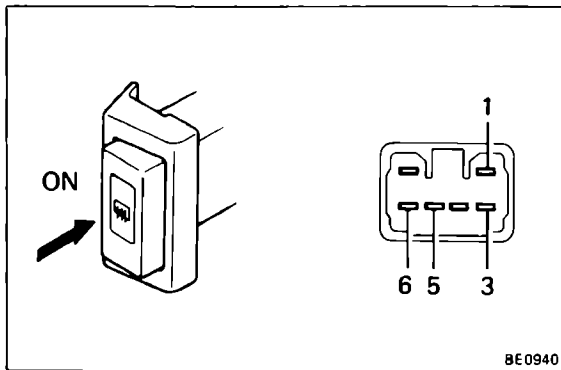

BE0940

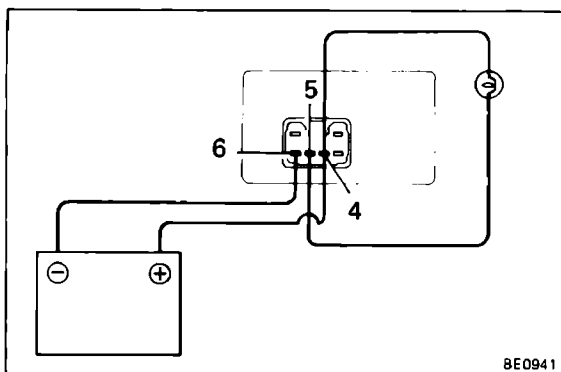

BE0941

(w/ Timer)

INSPECT SWITCH OPERATION

- (a) Connect the positive (+) lead from the battery to terminal 4 and connect the negative (–) lead to terminal 6. Connect terminals 4 and 5 through a 3.4W test bulb.
 - (b) Push the defogger switch ON. Check that the bulb lights for 12 to 18 minutes, then the bulb goes out.
- If operation is not as specified, replace the switch.

Rear Window Defogger Relay

(See Taillight Control Relay on page BE-18)

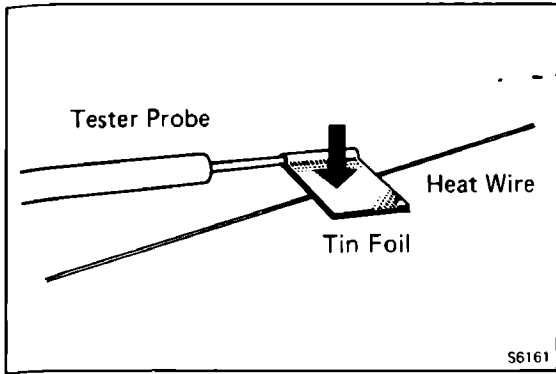

Rear Window Defogger Wires

CAUTION:

- When cleaning the glass, use a soft, dry cloth, and wipe the glass in the direction of the wire. Take care not to damage the wires.
- Do not use detergents or glass cleaners with abrasive ingredients.
- When measuring voltage, wind a piece of tin foil around the tip of the negative probe and press the foil against the wire with your finger as shown.

INSPECTION OF REAR WINDOW DEFOGGER WIRES

1. INSPECT FOR WIRE BREAKAGE

- (a) Turn the ignition switch to ON.
- (b) Turn the defogger switch to ON.

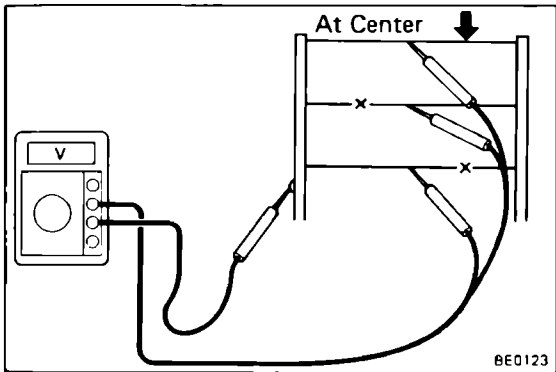

- (c) Inspect the voltage at the center of each heat wire as shown.

Voltage	Criteria
Approx. 5V	Okay (No break in wire)
Approx. 10V or 0V	Broken wire

NOTE: If there is 10 V, the wire is broken between the center of the wire and positive (+) end. If there is no voltage, the wire is broken between the center of the wire and ground.

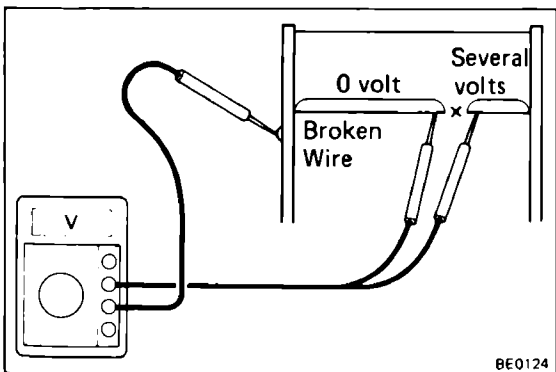

2. INSPECT FOR WIRE BREAKAGE POINT

- (a) Place the voltmeter positive (+) lead against the defogger positive (+) terminal.
- (b) Place the voltmeter negative (-) lead with the foil strip against the heat wire at the positive (+) terminal end and slide it toward the negative (-) terminal end.
- (c) The point where the voltmeter deflects from zero to several volts is the place where the heat wire is broken.

NOTE: If the heat wire is not broken, the voltmeter will indicate 0 V at the positive (+) end of the heat wire but gradually increases to about 12 V as the meter probe is moved to the other end.

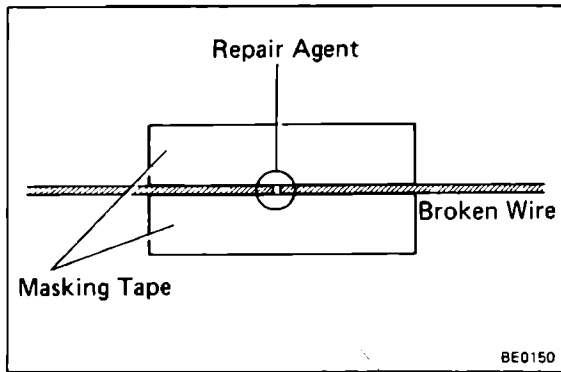

REPAIR OF REAR WINDOW DEFOGGER WIRES

1. CLEAN BROKEN WIRE TIPS WITH CLEANER
2. PLACE MASKING TAPE ALONG BOTH SIDES OF WIRE TO BE REPAIRED

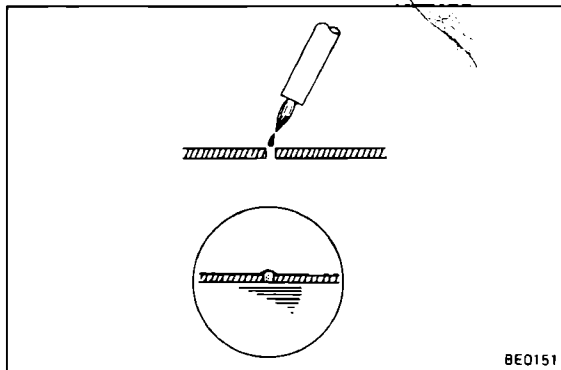

3. REPAIR DEFOGGER WIRES

- (a) Thoroughly mix the repair agent (Dupont paste No. 4817).
- (b) Using a fine tip brush, apply a small amount to the wire.
- (c) After a couple of minutes, remove the masking tape.
- (d) Allow the repair to stand at least 24 hours.

HEATER

Wiring Diagram (Push Type)

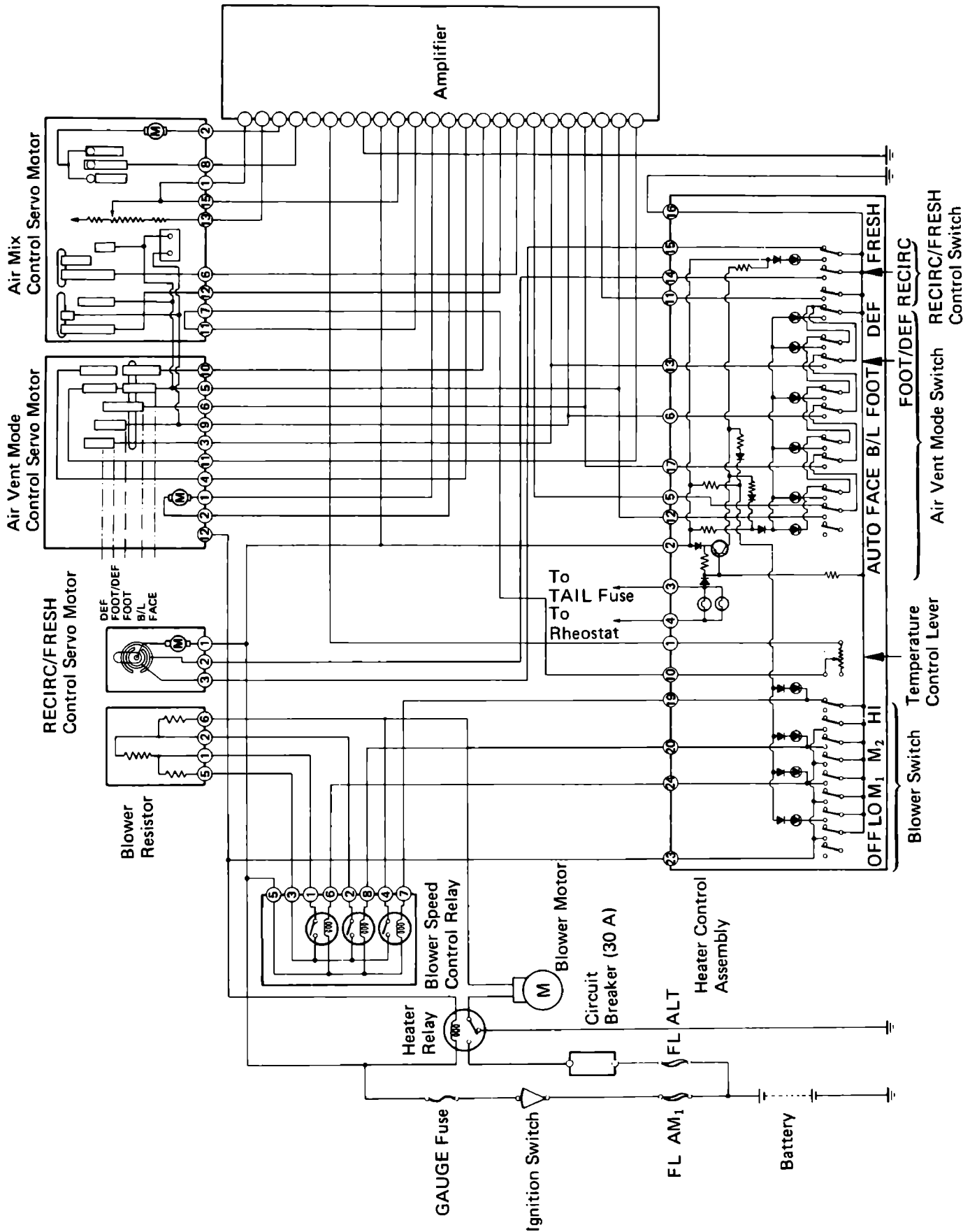

Connectors

Heater Control Assembly

Connector "A"

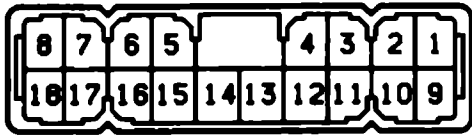

Connector "B"

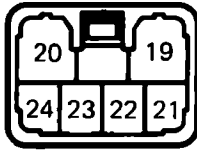

Amplifier

Connector "A"

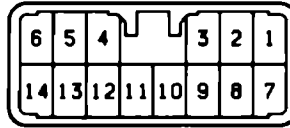

Connector "B"

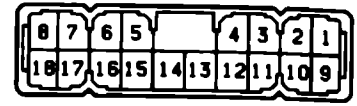

Air Vent Mode Control Servo Motor

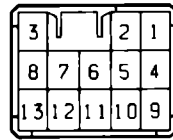

RECIRC/FRESH Control Servo Motor

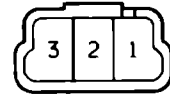

Air Mix Control Servo Motor

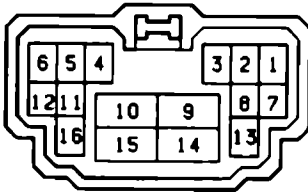

Blower Speed Control Relay

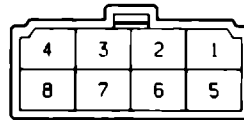

Blower Motor

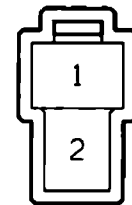

Blower Resistor



Light Control Switch

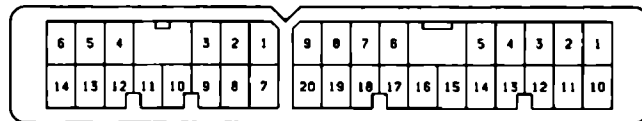

Taillight Control Relay

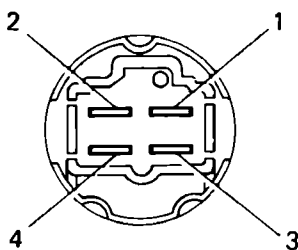

Heater Relay

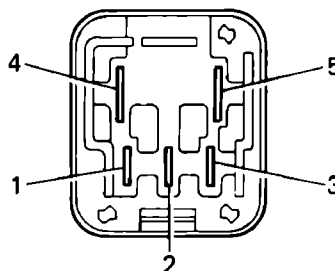

Troubleshooting

Problem	Possible cause	Remedy	Page	
			Push	Lever
Blower does not work when fan switch is on	Heater circuit breaker OFF	Reset breaker and check for short	BE-3	BE-3
	GAUGE fuse blown	Replace fuse and check for short	BE-4	BE-4
	Heater relay faulty	Check relay	BE-46	BE-46
	Blower speed control relay faulty	Check control relay	BE-48	
	Heater blower switch faulty	Check switch	BE-48	BE-45
	Heater blower resistor faulty	Check resistor	BE-46	BE-46
	Heater blower motor faulty	Check motor		
	Wiring or ground faulty	Repair as necessary		
Incorrect temperature output	Control cables broken or binding	Check cables	BE-50	BE-52
	Servo motor faulty	Check servo motor		
	Heater hoses leaking or clogged	Replace hoses		
	Water valve faulty	Replace water valve		
	Air dampers broken	Repair air dampers		
	Air ducts clogged	Repair air ducts		
	Heater radiator leaking or clogged	Repair heater radiator		
	Heater control unit faulty	Repair control unit		

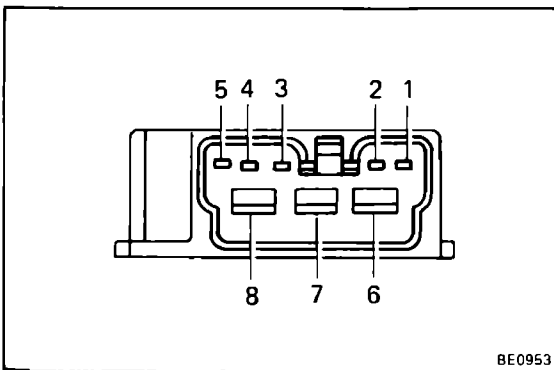

Heater Blower Switch (Lever Type)

INSPECTION OF HEATER BLOWER SWITCH

INSPECT SWITCH CONTINUITY

Inspect the heater blower switch continuity.

Terminal	6	5	1	2	8	*3	*4
Switch position							
OFF						○—○	○—○
LO	○—○					○—○	○—○
■	○—○—○					○—○	○—○
■	○—○—○—○					○—○	○—○
HI	○—○			○—○		○—○	○—○

*For illumination light

If continuity is not as specified, replace the switch.

Heater Relay

INSPECTION OF HEATER RELAY

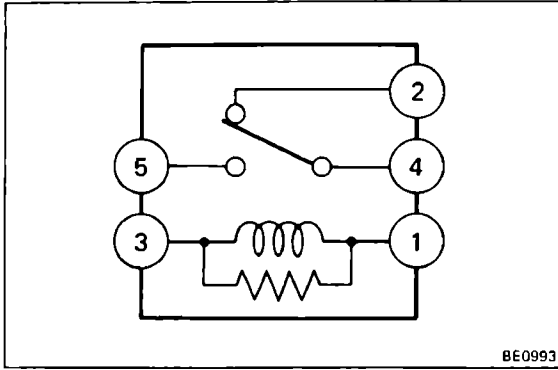

BE0993

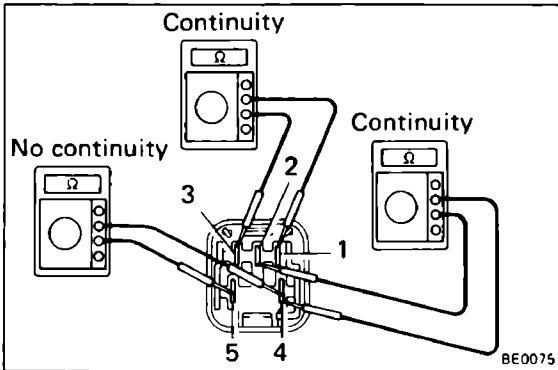

BE0075

1. INSPECT RELAY CONTINUITY

- (a) Check that there is continuity between terminals 1 and 3.
- (b) Check that there is continuity between terminals 2 and 4.
- (c) Check that there is no continuity between terminals 4 and 5.

If continuity is not as specified, replace the relay.

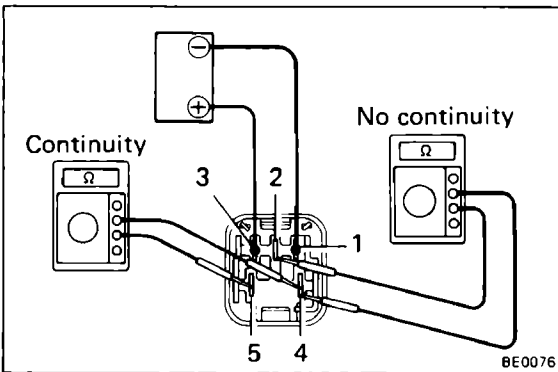

BE0076

2. INSPECT RELAY OPERATION

- (a) Apply battery voltage across terminals 1 and 3.
- (b) Check that there is continuity between terminals 4 and 5.
- (c) Check that there is no continuity between terminals 2 and 4.

If operation is not as specified, replace the relay.

Heater Blower Resistor

INSPECTION OF HEATER BLOWER RESISTOR

INSPECT RESISTOR CONTINUITY

(Lever type)

- Check that there is continuity between terminals 1 and 3.
- If there is no continuity, replace the resistor.

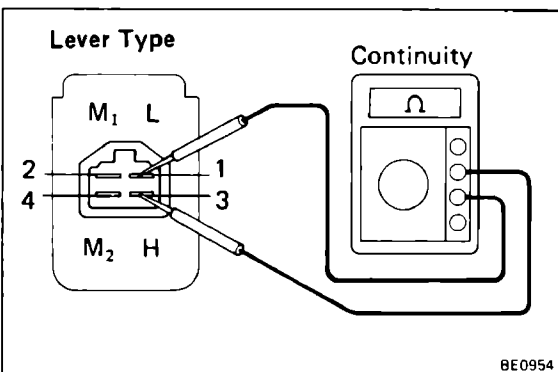

BE0954

(Push type)

- Check that there is continuity between terminals 5 and 6.
- If there is no continuity, replace the resistor.

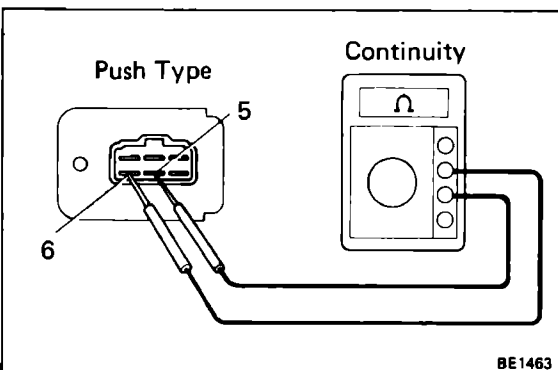

BE 1463

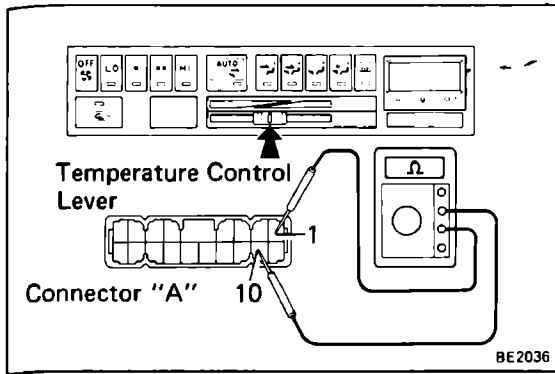

Heater Control Assembly (Push Type)

INSPECTION OF HEATER CONTROL ASSEMBLY

1. MEASURE TEMPERATURE CONTROL LEVER RESISTANCE

Measure the resistance between terminals A1 and A10 for each lever position.

Lever position	Resistance (kΩ)
Max. Cool	∞
Middle	1.5 ± 0.2
Max. Warm	0

If each resistance value is not as shown in the table above, replace the heater control assembly.

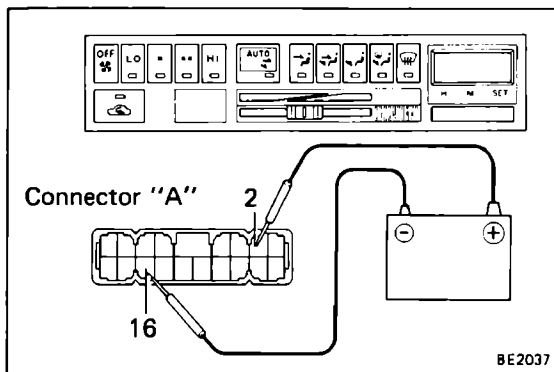

2. INSPECT INDICATOR LIGHT OPERATION

- Connect the positive (+) battery lead to terminal A2 and the negative (-) battery lead to terminal A16.
- With the blower button pushed in, check that the indicator light is lit. (The indicator light will not go on when the blower button is in the OFF position.)
- With the RECIRC/FRESH control button pushed in, check that the (RECIRC) indicator light is lit.
- Next, press the RECIRC/FRESH control button in again (FRESH) and check that the indicator light goes off.
- Press each of the mode buttons in and check that their indicator lights go on.

If operation is not as specified, replace the heater control.

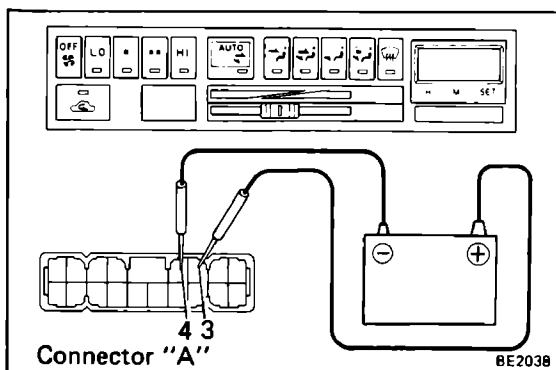

3. INSPECT ILLUMINATION OPERATION

Check that the illumination lights come on when the positive (+) battery lead is connected to terminal A3, and the negative (-) battery lead is connected to terminal A4.

If operation is not as specified, inspect the bulbs.

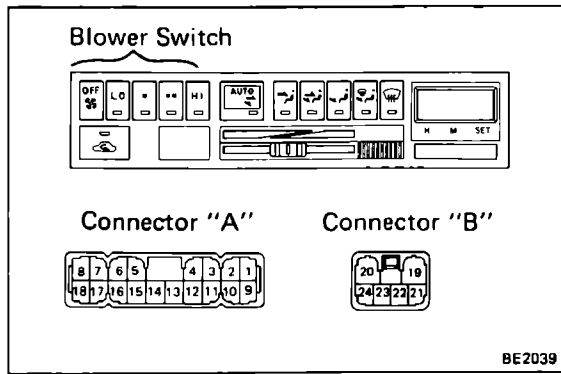

4. INSPECT BLOWER SWITCH CONTINUITY

Inspect the blower switch continuity between terminals.

Switch position \ Terminal	A16	B23	B24	B20	B19
OFF					
LO	○—○				
■	○—○—○				
■ ■	○—○—○—○				
HI	○—○—○—○—○				

If continuity is not as specified, replace the heater control.

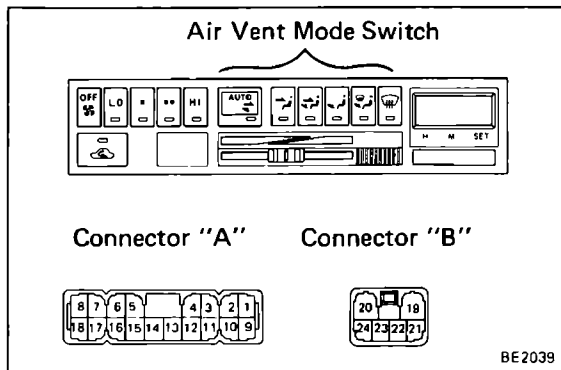

5. INSPECT AIR VENT MODE SWITCH CONTINUITY

Inspect the mode switch continuity between terminals.

Switch position \ Terminal	A16	A5	A12	A17	A6	A13	A11
AUTO	○—○						
FACE	○—○—○						
BI-LEVEL	○—○—○—○						
FOOT	○—○—○—○—○						
FOOT/DEF	○—○—○—○—○—○						
DEF	○—○—○—○—○—○—○						

If continuity is not as specified, replace the heater control.

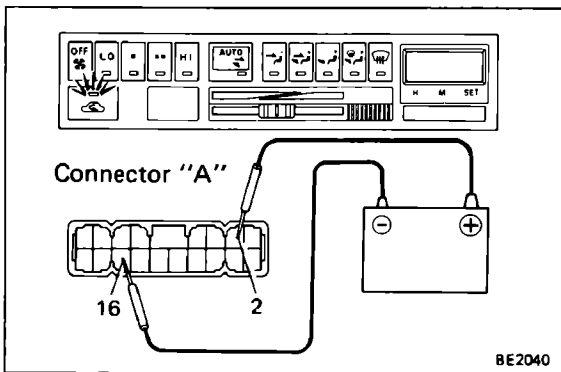

6. INSPECT RECIRC/FRESH CONTROL SWITCH OPERATION

- With the positive (+) battery lead connected to terminal A2, and the negative (-) battery lead connected to terminal A16, check that the RECIRC indicator light comes on.
- Remove the battery leads.
- Check that there is continuity between terminals A15 and A16, and no continuity between terminals A14 and A16 with the control switch is FRESH.
- Check that there is continuity between terminals A14 and A16, and no continuity between terminals A15 and A16 with the control switch is RECIRC.

If operation is not as specified, replace the heater control.

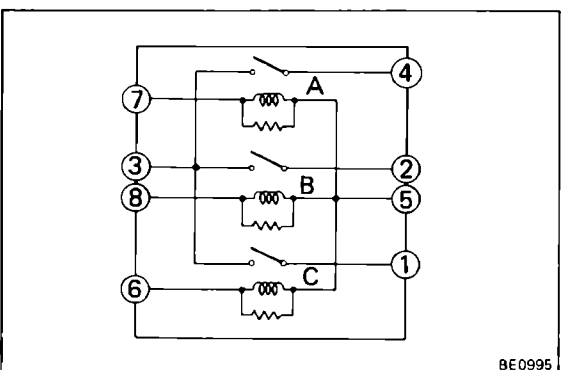
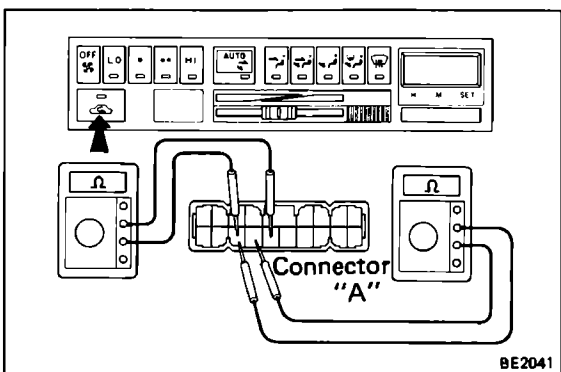

Blower Speed Control Relay (Push Type)

INSPECTION OF BLOWER SPEED CONTROL RELAY

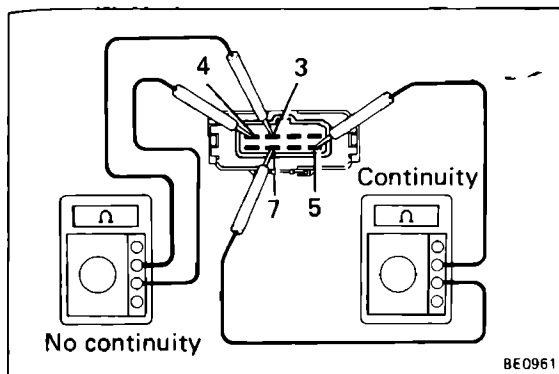

1. INSPECT RELAY "A" CONTINUITY

- (a) Check that there is continuity between terminals 5 and 7.
- (b) Check that there is no continuity between terminals 3 and 4.

If continuity is not as specified, replace the relay.

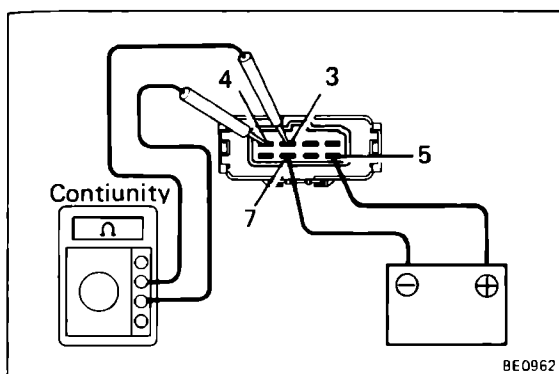

2. INSPECT RELAY "A" OPERATION

- (a) Apply battery voltage across terminals 5 and 7.
- (b) Check that there is continuity between terminals 3 and 4.

If operation is not as specified, replace the relay.

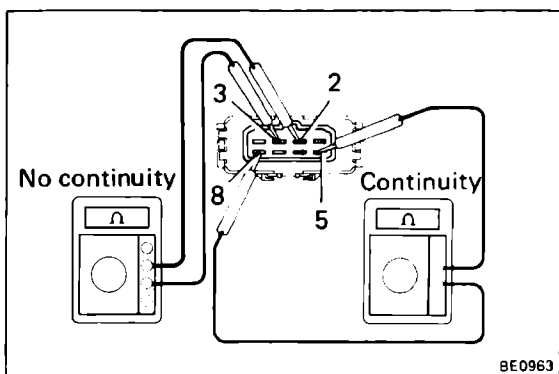

3. INSPECT RELAY "B" CONTINUITY

- (a) Check that there is continuity between terminals 5 and 8.
- (b) Check that there is no continuity between terminals 2 and 3.

If continuity is not as specified, replace the relay.

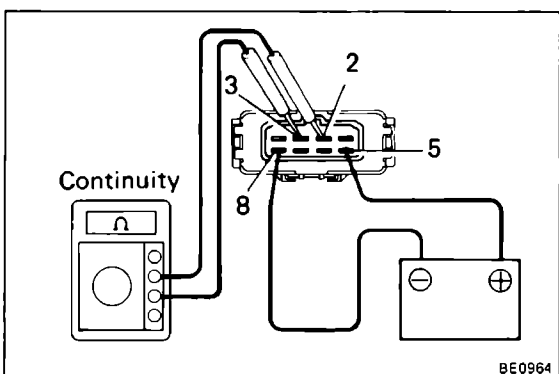

4. INSPECT RELAY "B" OPERATION

- (a) Apply battery voltage across terminals 5 and 8.
- (b) Check that there is continuity between terminals 2 and 3.

If operation is not as specified, replace the relay.

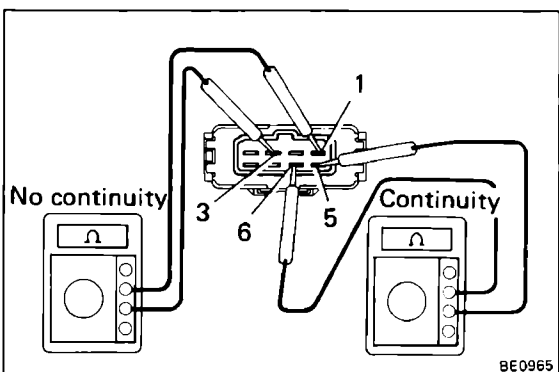

5. INSPECT RELAY "C" CONTINUITY

- (a) Check that there is continuity between terminals 5 and 6.
- (b) Check that there is no continuity between terminals 1 and 3.

If continuity is not as specified, replace the relay.

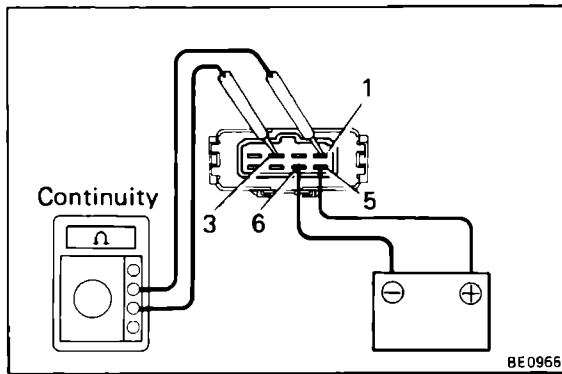

6. INSPECT RELAY "C" OPERATION

- Apply battery voltage across terminals 5 and 6.
- Check that there is continuity between terminals 1 and 3.

If operation is not as specified, replace the relay.

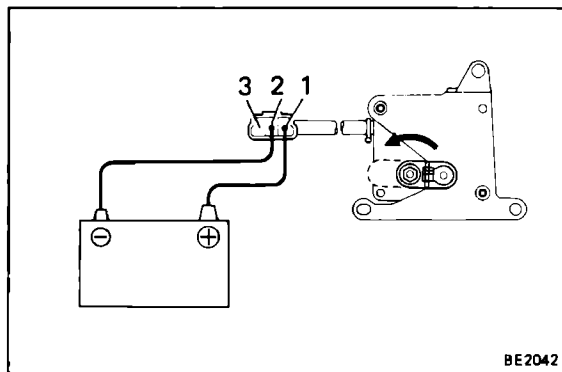

RECIRC/FRESH Control Servo Motor (Push Type)

INSPECTION OF SERVO MOTOR

INSPECT SERVO MOTOR OPERATION

- With the positive (+) lead from the battery connected to terminal 1 and negative (-) lead connected to terminal 2, check that the lever moves smoothly from FRESH to RECIRC.
- With the positive (+) lead from the battery connected to terminal 1 and negative (-) lead connected to terminal 3, check that the lever moves smoothly from RECIRC to FRESH.

If operation is not as specified, replace the servo motor.

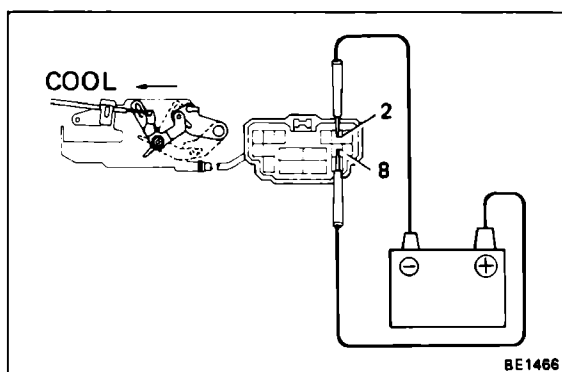
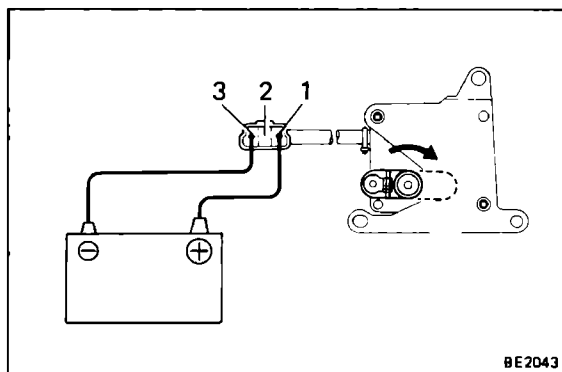

Air Mix Control Servo Motor (Push Type)

INSPECTION OF AIR MIX CONTROL SERVO MOTOR

INSPECT SERVO MOTOR OPERATION

- With the positive (+) battery lead connected to terminal 8, and the negative (-) battery lead connected to terminal 2, check that the lever moves smoothly from WARM to COOL.
- With the positive (+) battery lead connected to terminal 2, and the negative (-) battery lead connected to terminal 8, check that the lever moves smoothly from COOL to WARM.

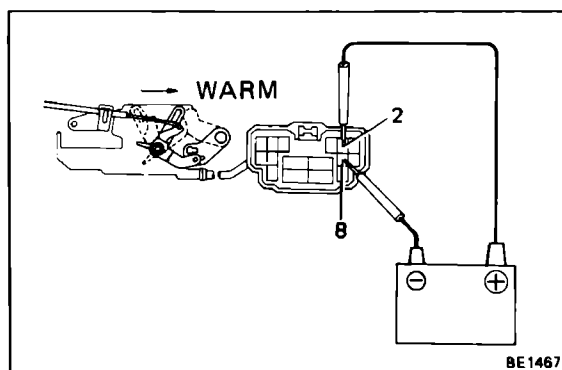

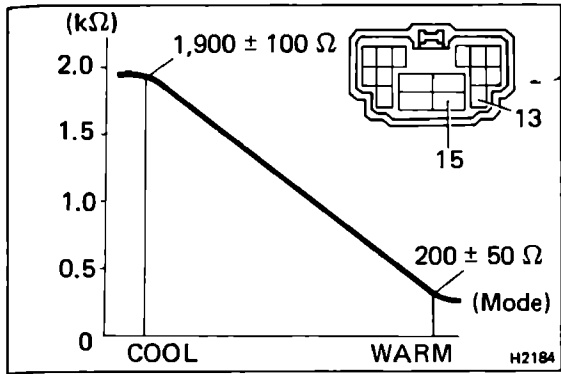

(c) While operating the servo motor from either points (a) or (b), measure the resistance values of terminals 13 and 15.

Position	Resistance (Ω)
COOL	1,900 ± 100
WARM	200 ± 50

The resistance values from COOL to WARM will successively decrease.

If operation is not as specified, replace the servo motor.

Air Vent Mode Control Servo Motor (Push Type)

INSPECTION OF SERVO MOTOR

INSPECT SERVO MOTOR OPERATION

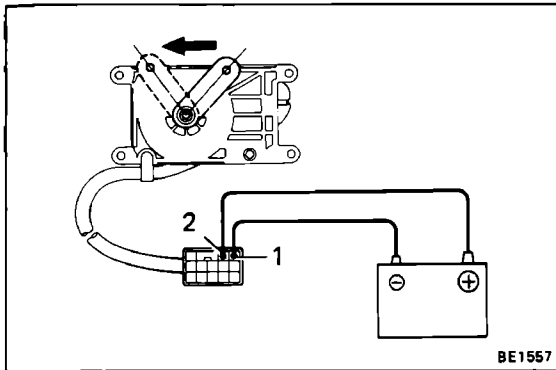

(a) Connect the positive (+) lead from the battery to terminal 2 and negative (-) lead to terminal 1, check that the lever moves smoothly from FACE to DEF.

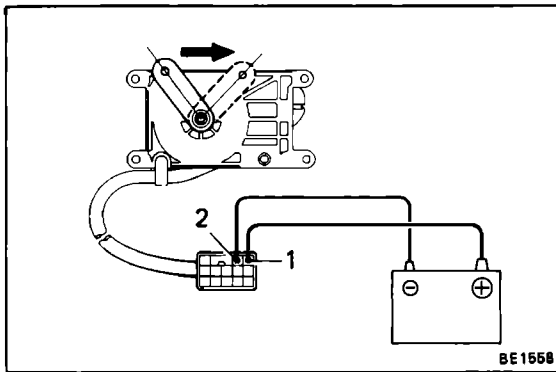

(b) Connect the positive (+) lead from the battery to terminal 1 and negative (-) lead to terminal 2, check that the lever moves smoothly from DEF to FACE.

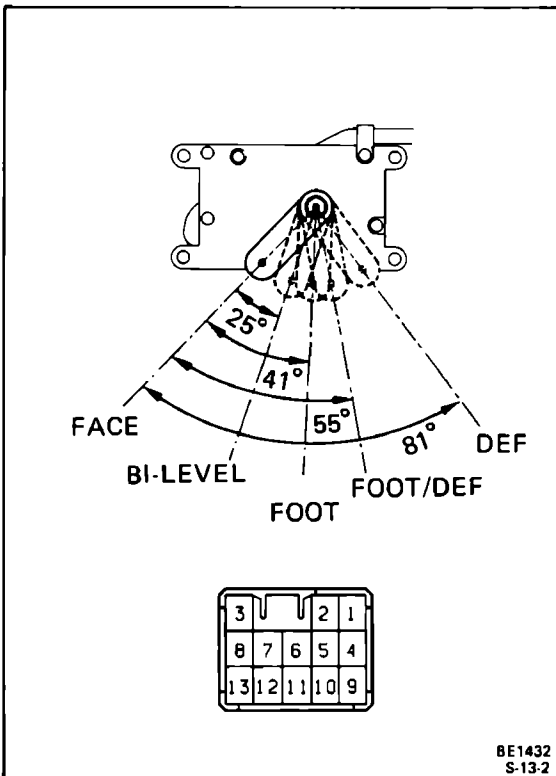

(c) Check for continuity between terminal as shown below.

Lever position \ Terminal	Terminal						
	3	5	4	6	10	11	9
FACE							
BI-LEVEL		○ ←			○		
FOOT		○ ←		○	○		
FOOT/DEF		○ ←		○	○	→	○
DEF	○ ←		○	○		○	→

If operation is not as specified, replace the motor.

Heater Control (Lever Type)

ADJUSTMENT OF HEAT CONTROL

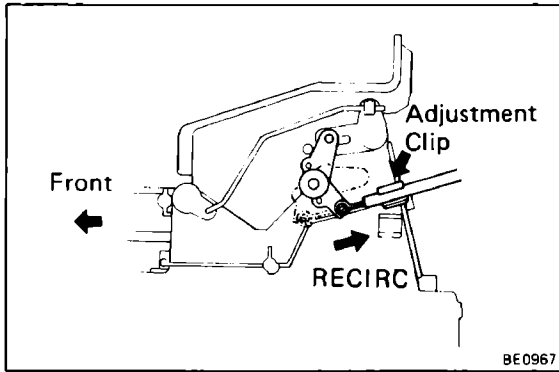

1. SET AIR INLET DAMPER

Set the air inlet damper and control lever to "RECIRC."

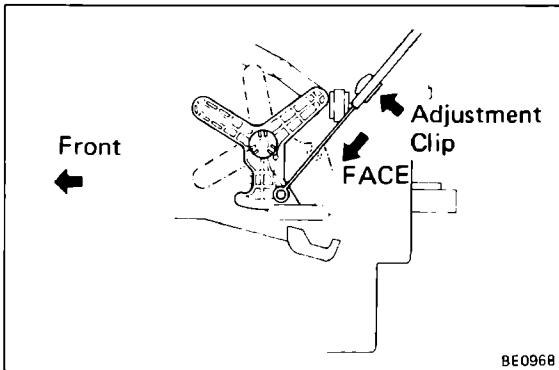

2. SET MODE SELECTOR DAMPER

Set the mode selector damper and control lever to "FACE."

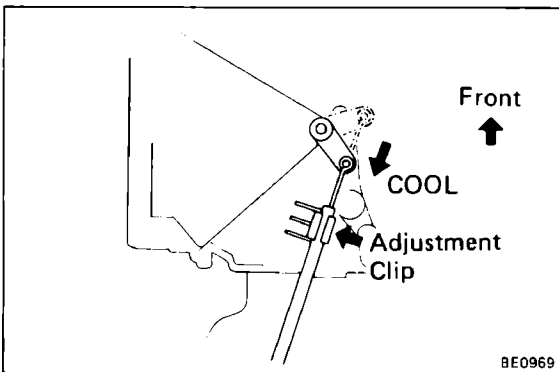

3. SET AIR MIX DAMPER

Set the air mix damper and control lever to "COOL."

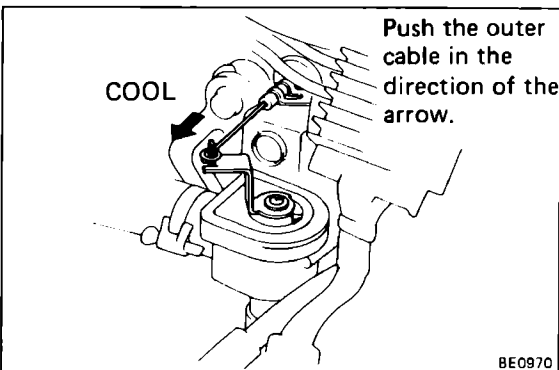

4. SET WATER VALVE

Set the water valve and control lever to "COOL."

NOTE: Place the water valve lever on "COOL" and while pushing the outer cable in the "COOL" direction, clamp the outer cable to the water valve bracket.

5. TEST CONTROL CABLE OPERATION

Move the control levers right and left and check for stiffness or binding through the full range of the levers.

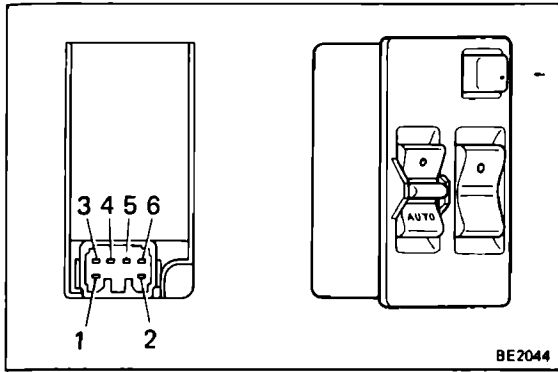

POWER WINDOW

Power Window Master Switch

INSPECTION OF POWER WINDOW MASTER SWITCH

INSPECT SWITCH CONTINUITY

Inspect the switch continuity between terminals.

Operation window		Driver's side				Passenger's side			
Terminal		1	2	6	5	1	3	4	5
Window Unlock	UP	○—○		○—○		○—○		○—○	
	OFF		○—○		○—○		○—○		○—○
	DOWN	○—○		○—○		○—○		○—○	
Window Lock	UP	○—○		○—○		○—○			
	OFF		○—○		○—○		○—○		
	DOWN	○—○		○—○		○—○			

If continuity is not as specified, replace the switch.

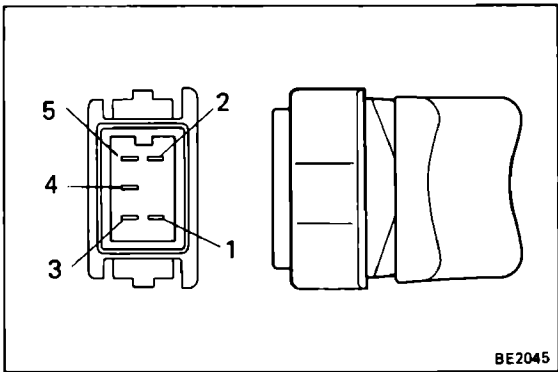

Power Window Door Switch

INSPECTION OF POWER WINDOW DOOR SWITCH

INSPECT SWITCH CONTINUITY

Inspect the switch continuity between terminals.

Terminal		5	1	2	3	4
UP		○—○			○—○	○—○
OFF			○—○		○—○	○—○
DOWN		○—○		○—○		○—○

If continuity is not as specified, replace the switch.

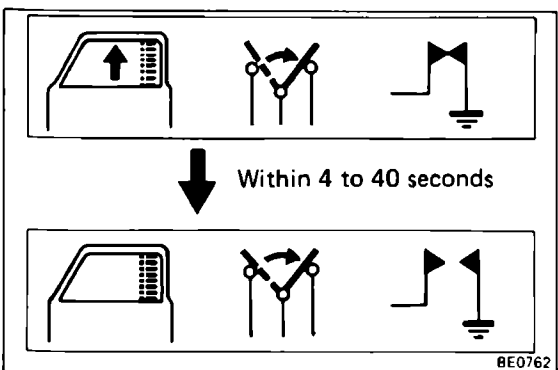

Power Window Motor

INSPECTION OF POWER WINDOW MOTOR

1. INSPECT CIRCUIT BREAKER OPERATION

- (a) With the window in the full closed position, hold the power window switch in "UP" position and check that there is a circuit breaker operation noise within 4 to 40 seconds.

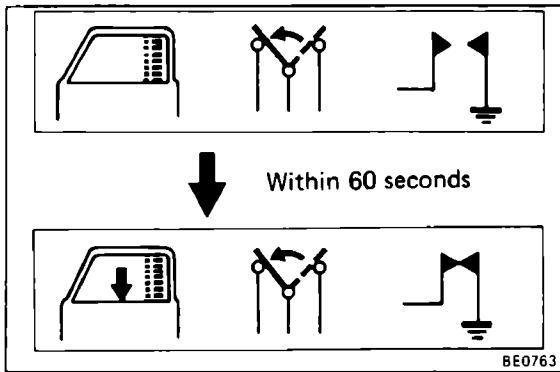

- (b) With the window in the full closed position, hold the switch in "DOWN" and check that the window begins to descend within 60 seconds.

If operation is not as specified, replace the motor.

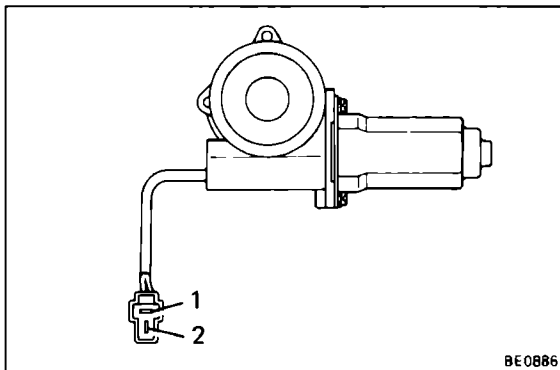

2. INSPECT MOTOR OPERATION

- (a) Connect the positive (+) lead from the battery to terminal 1 and negative (-) lead to terminal 2, and check that the motor turns.
- (b) Connect the positive (+) lead from the battery to terminal 2 and negative (-) lead to terminal 1, and check that the motor turns the opposite way.

If operation is not as specified, replace the motor.

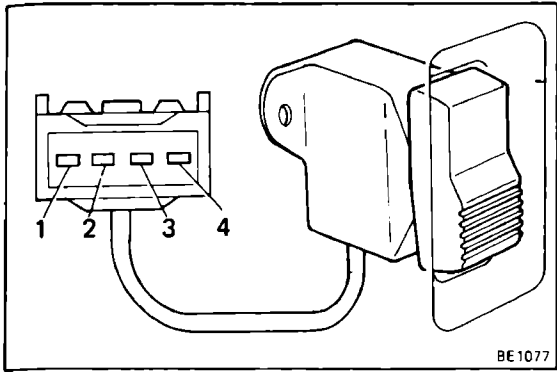

DOOR LOCK CONTROL SYSTEM

Door Lock Control Switch

INSPECTION OF DOOR LOCK CONTROL SWITCH

INSPECT SWITCH CONTINUITY

Inspect the switch continuity between terminals.

Switch position \ Terminal	3	4	1
LOCK	○ — ○		○
OFF			
UNLOCK		○ — ○	

If continuity is not as specified, replace the switch.

Unlock Warning Switch

(See page BE-14)

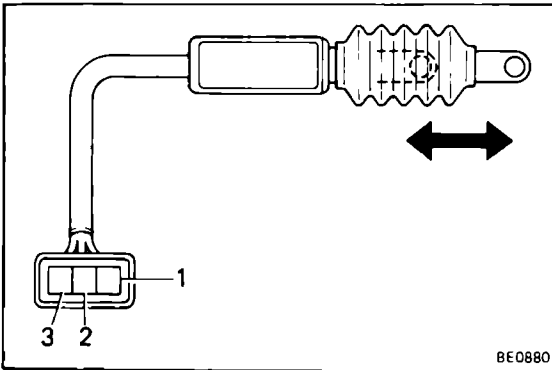

Door Lock Key Switch

INSPECTION OF DOOR LOCK KEY SWITCH

INSPECT CONTINUITY OF DOOR LOCK KEY SWITCH

Inspect the switch continuity between terminals.

Switch position \ Terminal	3	2	1
LOCK	○ — ○	○	
UNLOCK		○ — ○	

If continuity is not as specified, replace the switch.

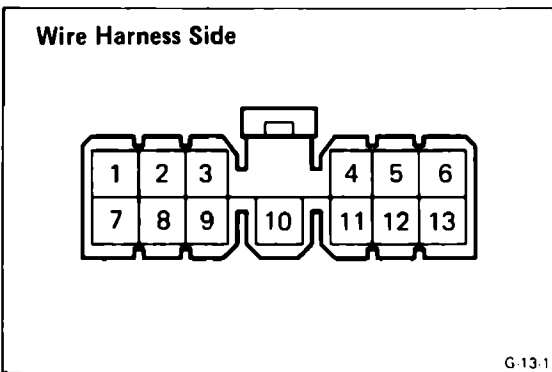

Door Lock Control Relay

INSPECTION OF DOOR LOCK CONTROL RELAY

INSPECT DOOR LOCK CONTROL RELAY CIRCUIT

- (a) Disconnect the relay connector and inspect the connector on the wire harness side as shown in the following chart.

Check For	Tester Connection	Condition	Specified Value
Continuity	1 – Body ground	LH door opened	Continuity
		LH door closed	No continuity
Voltage	2 – Body ground	—	Battery voltage
Continuity	6 – Body ground	Turn the following switches, one by one to lock <ul style="list-style-type: none"> • Control switch • LH door key switch • RH door key switch 	Continuity
		Turn the following switches, one by one to except lock <ul style="list-style-type: none"> • Control switch • LH door key switch • RH door key switch 	No continuity
	7 – Body ground	RH door opened	Continuity
		RH door closed	No continuity
	9 – Body ground	LH door lock switch to unlock	Continuity
		LH door lock switch to lock	No continuity
	10 – Body ground	—	Continuity
		11 – Body ground	RH door lock switch to unlock
	11 – Body ground	RH door lock switch to lock	No continuity
		12 – Body ground	Set unlock warning switch ON (Insert ignition key)
	Set unlock warning switch OFF (Remove ignition key)		No continuity
	13 – Body ground	Turn the following switches, one by one to unlock <ul style="list-style-type: none"> • Control switch • LH door key switch • RH door key switch 	Continuity
		Turn the following switches, one by one to except unlock <ul style="list-style-type: none"> • Control switch • LH door key switch • RH door key switch 	No continuity

- (b) Connect the positive (+) lead from the battery to terminal 3 and the negative (–) lead to terminal 4, check that the solenoids operate unlock direction. Then, reverse the polarity, check that the solenoids operate lock direction. If any of the solenoids does not operate, remove and test the solenoid.

If circuit operation is correct, replace the relay.

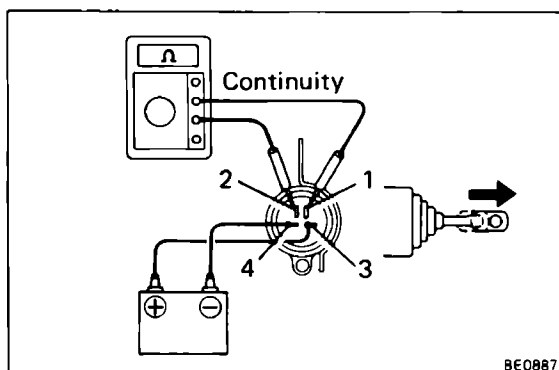

Door Lock Solenoid

INSPECTION OF DOOR LOCK SOLENOID

INSPECT SOLENOID OPERATION

- (a) Connect the positive (+) lead from the battery to terminal 3. Connect the negative (–) lead to terminal 4. Check the solenoid operates in the unlock direction.
- (b) Check that there is continuity between terminals 1 and 2.

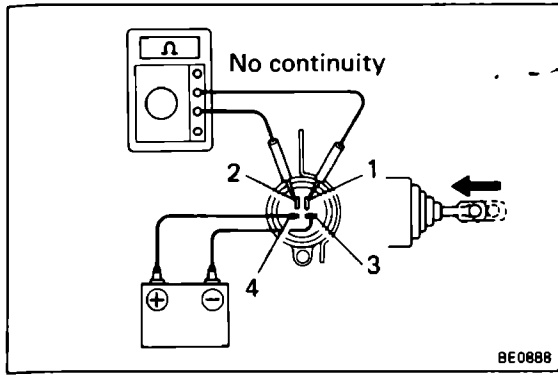

(c) Connect the positive (+) lead from the battery to terminal 4. Connect the negative (-) lead to terminal 3. Check that the solenoid operates in the lock direction.

(d) Check that there is no continuity between terminals 1 and 2.

If operation is not as specified, replace the solenoid.

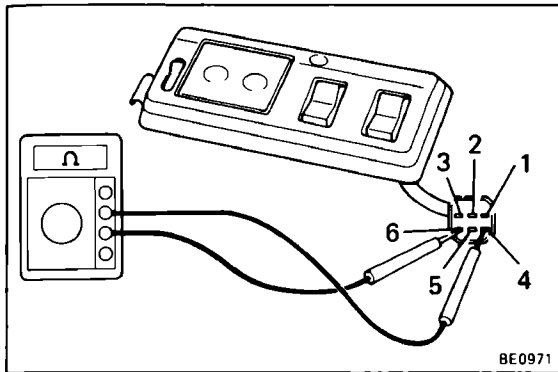

SUN ROOF

Sun Roof Switch

INSPECTION OF SUN ROOF SWITCH

INSPECT SWITCH CONTINUITY

Inspect the switch continuity between terminals.

Switch position		Terminal (Wire color)	1 (GR)	2 (R-W)	3 (G-W)	4 (W-B)	5 (R-Y)	6 (G-Y)
		Slide switch	OPEN			○—○		
Slide switch	CLOSE				○—○			
Tilt switch	DOWN		○—○					
	UP				○—○			
Map light	ON		○—○					
	OFF							

If continuity is not as specified, replace the switch.

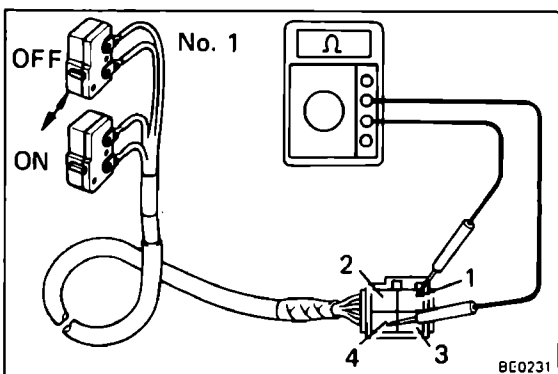

Limit Switch

INSPECTION OF LIMIT SWITCH

1. INSPECT NO. 1 SWITCH CONTINUITY

(a) Check that there is continuity between terminals 1 and 4 when the No. 1 switch is ON.

(b) Check that there is no continuity between terminals 1 and 4 when the No. 1 switch is OFF.

If continuity is not as specified, replace the switch.

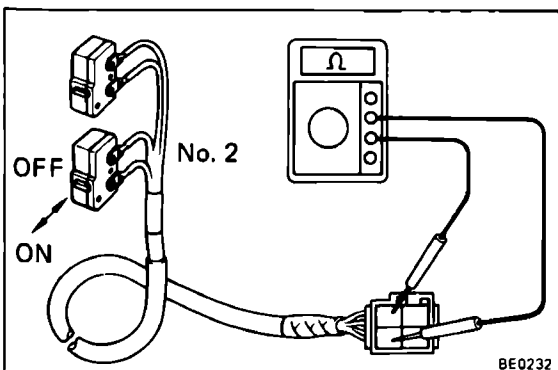

2. INSPECT NO. 2 SWITCH CONTINUITY

(a) Check that there is continuity between terminals 2 and 4 when the No. 2 switch is ON.

(b) Check that there is no continuity between terminals 2 and 4 when the No. 2 switch is OFF.

If continuity is not as specified, replace the switch.

(See page BO-53)

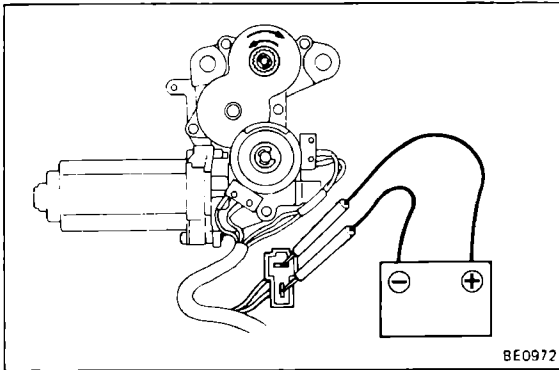

BE0972

Sun Roof Motor

INSPECTION OF SUN ROOF MOTOR

INSPECT MOTOR OPERATION

- (a) Connect the positive (+) lead from the battery to terminal 1 and the negative (–) lead to terminal 2 and check that the motor turns clockwise.
- (b) Connect the positive (+) lead from the battery to terminal 2 and the negative (–) lead to terminal 1 and check that the motor turns counterclockwise.

If operation is not as specified, replace the motor.

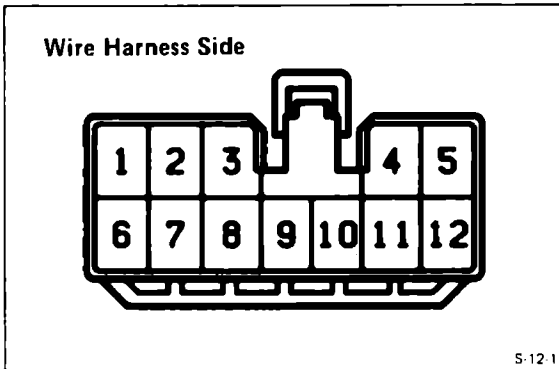

5-12.1

Sun Roof Control Relay

INSPECTION OF SUN ROOF CONTROL RELAY

INSPECT RELAY VOLTAGE AND CONTINUITY

- (a) Disconnect the relay connector and inspect the connector on the wire harness side as shown in the below.

Check for	Tester connection	Condition	Specified value
Continuity	2 – Body ground	Push sun roof switch to UP	Continuity
		Push sun roof switch to except UP	No continuity
	4 – Body ground	Limit switch No. 2 on	Continuity
		Limit switch No. 2 off	No continuity
Voltage	6 – Body ground	Turn ignition switch on	Battery voltage
		Turn ignition switch off	No voltage
Continuity	7 – Body ground	Push sun roof switch to CLOSE	Continuity
		Push sun roof switch to except CLOSE	No continuity
	8 – Body ground	Push sun roof switch to OPEN	Continuity
		Push sun roof switch to except OPEN	No continuity
	9 – Body ground	Push sun roof switch to DOWN	Continuity
		Push sun roof switch to except DOWN	No continuity
	10 – Body ground	Limit switch No. 1 on	Continuity
		Limit switch No. 1 off	No continuity
	12 – Body ground	—	Continuity

- (b) Connect the positive (+) lead from the battery to terminal 1 and the negative (–) lead to terminal 5, check that the sun roof (motor) operates to close and tilt up. Then, reverse the polarity, check that the sun roof (motor) operates to tilt down and open. If motor does not operate, remove and test the motor.

If circuit operation is correct, replace the relay.

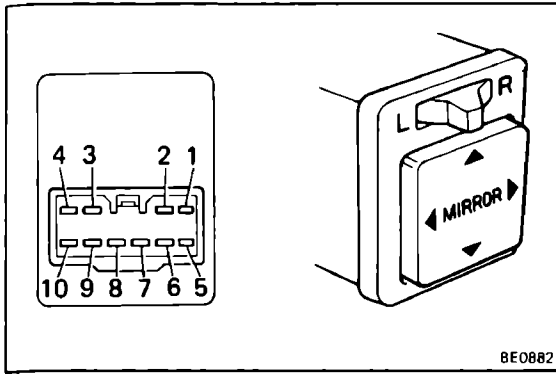

REMOTE CONTROL MIRROR

Mirror Switch

INSPECTION OF MIRROR SWITCH

INSPECT SWITCH CONTINUITY

Inspect the switch continuity between terminals.

Mirror Terminal	Left				Right				
	10	9	1	4	3	4	1	2	6
UP	○—○			○—○	○—○		○—○		
DOWN	○—○		○—○		○—○		○—○		
LEFT		○—○		○—○	○—○		○—○		
RIGHT		○—○		○—○		○—○		○—○	

If continuity is not as specified, replace the switch.

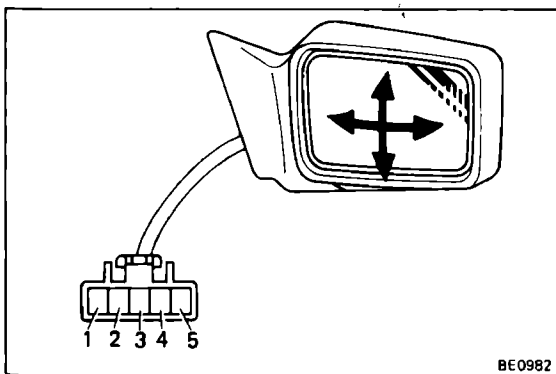

Remote Control Mirror

INSPECTION OF REMOTE CONTROL MIRROR

INSPECT MIRROR OPERATION

- (a) Connect the positive (+) lead from the battery to terminal 3 and negative (-) lead to terminal 4, and check that the mirror moves downward.
Then, reverse the polarity, and check that the mirror revolution is reversed.
- (b) Connect the positive (+) lead from the battery to terminal 3 and negative (-) lead to terminal 2, and check that the mirror moves to the right.
Then, reverse the polarity, and check that the mirror revolution is reversed.

If operation is not as specified, replace the mirror.

MIRROR HEATER

Rear Window Defogger and Mirror Heater Switch

INSPECTION OF REAR WINDOW DEFOGGER SWITCH

(See page BE-37)

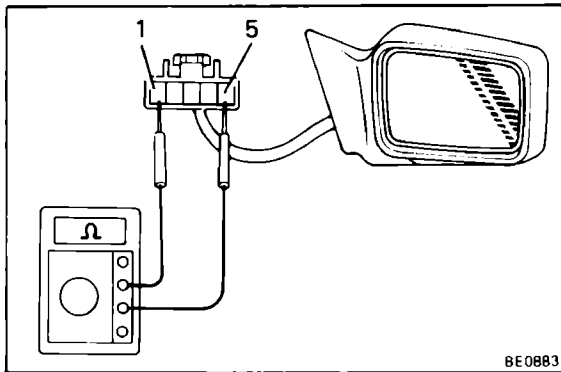

Mirror Heater

INSPECTION OF MIRROR HEATER

MEASURE MIRROR HEATER RESISTANCE

Measure the resistance between terminals 1 and 5.

Resistance: 5 – 30Ω

If resistance value is not correct, replace the mirror.

NOTE: The resistance value increases as the temperature rises.

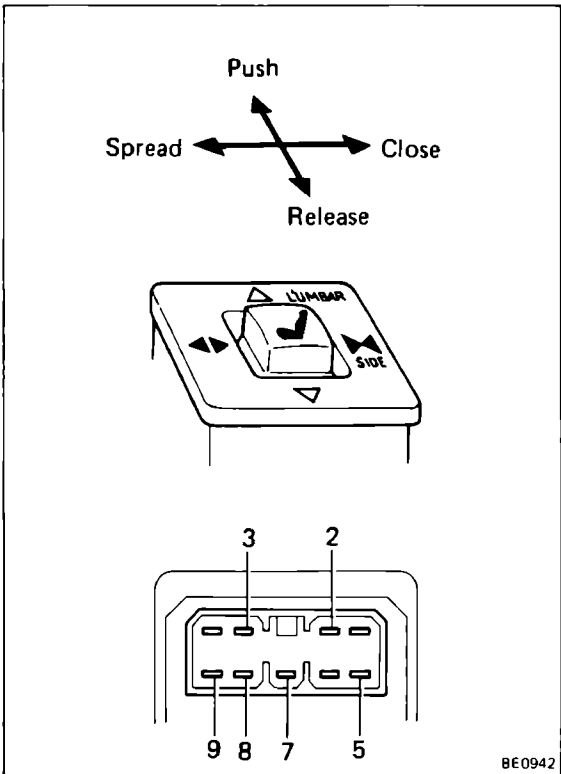

POWER SEAT

Power Seat Switch

INSPECTION OF POWER SEAT SWITCH

INSPECT SWITCH CONTINUITY

Inspect the switch continuity between terminals.

Switch position		Terminal					
		7	8	2	9	5	3
LUMBAR	Push	○		○			
	Off		○	○	○		
	Release	○		○		○	
SIDE	Spread	○				○	
	Off		○			○	○
	Close	○					○

If continuity is not as specified, replace the switch.

Power Seat Motors

INSPECTION OF POWER SEAT MOTORS

INSPECT MOTOR OPERATION

- Apply battery voltage to both terminals of the connector and check that the motor operates.
- Then, reverse the polarity, and check that the motor revolution is reversed.
- Similarly check the other motors.

If operation is not as specified, replace the motor.

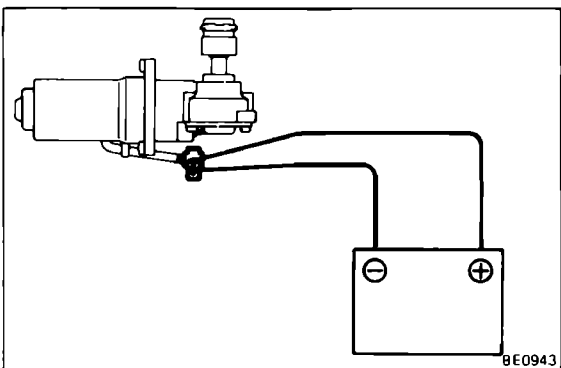

CRUISE CONTROL SYSTEM

Wiring Diagram

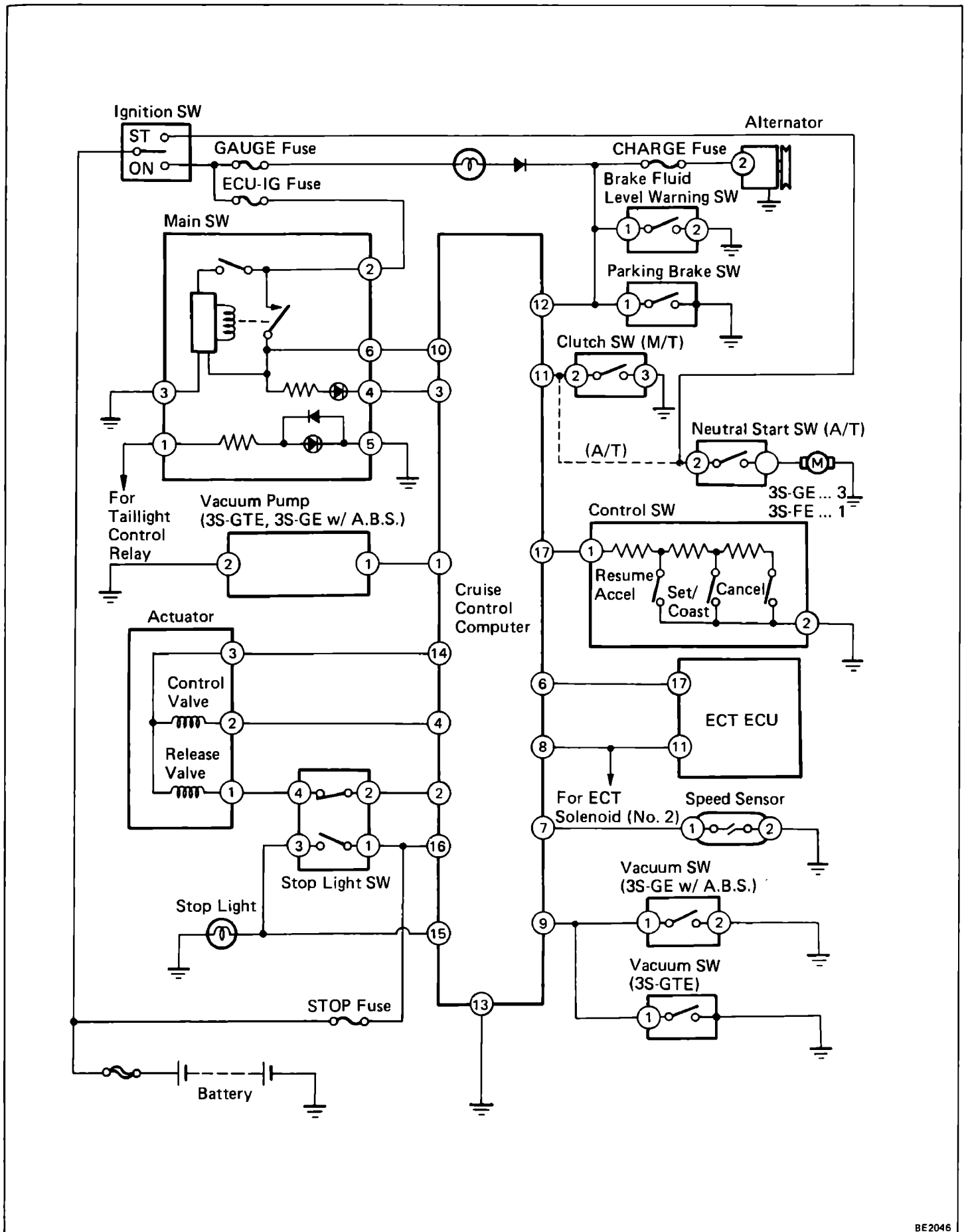

Connectors

Cruise Control Computer

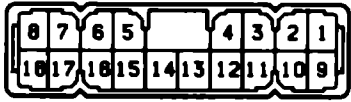

Main SW

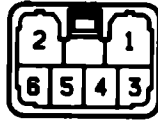

Control SW

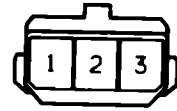

Parking Brake SW



Neutral Start Switch
(3S-GE) (3S-FE)

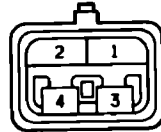

Actuator

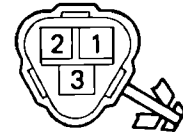

Clutch SW



Speed Sensor



Stop Light Switch

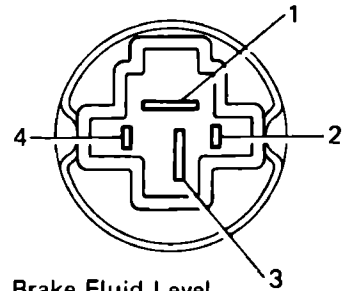

ECT Computer
Wire Harness Side

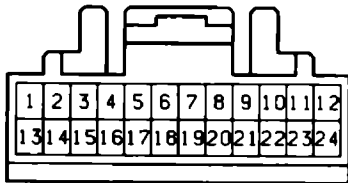

Alternator
Wire Harness Side



Brake Fluid Level
Warning Switch

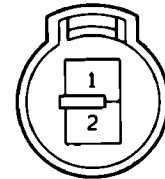

(3S-GTE)

Vacuum SW



(3S-GE w/ A.B.S.)

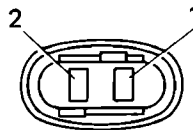

Vacuum Pump
(3S-GTE, 3S-GE w/ A.B.S.)

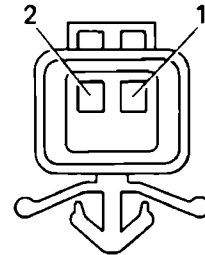

S-18-2-A S-6-2 GA-3-1
H-1-2 SH-9-2-A SH-4-2-A BE2124
H-3-2 IS-2-2-B BE0336
R-24-1 IA-3-1-C IC-2-2
IS-1-2-A BE2047 BE2048

System Description

The system description is as follows:

When the ignition switch is turned on, the current is led from the battery to Terminal 2 of the Main switch.

1. Main Switch Operation

When the CCS main SW is turned on, the current flows through Terminal 2 → Terminal 3 of the CCS main SW → body ground.

And then, turns on (closes) the relay contact in the main SW. As a result, current flows from Terminal 2 → Terminal 6 of the main SW → So it is supplied to Terminal 10 of the CCS computer.

Also, current flows from Terminal 2 → the indicator light → Terminal 4 of main switch SW → Terminal 3 of CCS computer.

Therefore, the main SW remains on and continues to supply current to the CCS computer.

2. Control Switch Operation

The control SW controls the SET, COAST, RESUME, ACCEL and CANCEL functions.

When the control SW is turned to each position → Sends a signal (each voltage) to Terminal 1 of control switch → Terminal 17 of CCS computer.

Then, the vehicle speed at the moment the SW (SET) is released is registered in memory.

3. Speed Control Operation

When the vehicle speed is set by the control SW, the CCS computer sends a signal from Terminal 2 of CCS computer to Terminal 2 → Terminal 4 of stop light SW → Terminal 1 of actuator (release valve side).

At the same time, the CCS computer sends a signal from terminal 4 of the CCS computer to Terminal 2 of actuator (control valve side).

Then, the actuator increases or decreases the throttle valve opening angle in accordance with the signal from the CCS computer.

4. Cancel Switch Operation

The CCS is provided with several types of cancel SW, such as the Control SW (CANNCEL), the Stop Light SW, the Parking Brake SW, the Neutral Start SW and the clutch SW.

(a) Speed Control SW (CANCEL)

When the Control SW is turned to CANCEL → Sends a cancellation signal to the Terminal 1 of control SW → Terminal 17 of CCS computer.

(b) Parking Brake SW

When the parking brake lever is pulled, the Parking Brake SW is turned on → Sends a cancellation signal (earth voltage) to Terminal 12 of the CCS computer.

(c) Neutral Start SW (A/T)

When the shift lever is set to the N or P range, the Neutral Start SW goes on → Sends a cancellation signal (earth voltage) to Terminal 11 of CCS computer.

(d) Clutch SW (M/T)

When the clutch pedal is depressed, the Clutch SW goes on → Sends a cancellation signal (earth voltage) to Terminal 11 of CCS computer.

(e) Stop Light SW

When the brake pedal is depressed, SW A of the stop light SW is turned off → the release valve (in actuator) is opened, and SW B of the stop light SW is turned on → Sends a cancelation signal to Terminal 16 of CCS computer.





Therefore, the operation of the CCS is canceled and the actuator is shut off due to the operation of these switches.

Diagnosis System

OUTPUT OF DIAGNOSTIC CODES

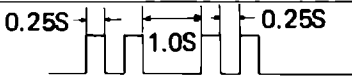
1. READ TYPE A CODE

- (a) Turn the ignition switch on.
- (b) Push the set/coast switch on, and keep it on.
- (c) Push the main switch on.
- (d) Push the set/coast switch off.
- (e) Meet the conditions listed below.
- (f) Read the diagnostic code on the main switch indicator.

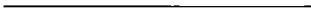
No.	Conditions	Indication Code	Diagnosis
1	Set/coast switch on	ON OFF 	Set/coast switch circuit is normal.
2	Resume/accel switch on	ON OFF 	Resume/accel switch circuit is normal.
3	Vacuum switch on (3S-GTE, 3S-GE w/ A.B.S.)	ON OFF 	Vacuum switch circuit is normal.
4	Each cancel switch on (Stop light switch, Parking brake switch, Clutch switch, Neutral start switch, Cancel switch)	ON OFF 	Each cancel switch circuit is normal.
5	Drive 40 km/h (25 mph) or over	ON OFF 	Speed sensor circuit is normal.
6	Drive 30 km/h (19 mph) or below	ON OFF 	Speed sensor circuit is normal.

BE0658

NOTE:

- To save time performing the next test, do not turn off the ignition switch when steps (a) – (f) are completed.
- Checking of No. 4 code is done with the vehicle jacked up and the engine idling.
- If there is no indication code, perform diagnosis and inspection. (See page BE-67)

2. READ TYPE B CODE

- (a) If while driving with the cruise control on, the system is cancelled by a malfunction in either the actuator, speed sensor, or control switch circuit, the main switch indicator will blink 5 times.
- (b) While driving at a speed of 16 km/h (10 mph) or less, press the SET/COAST switch three times in two seconds.

NOTE: In order to retain the diagnostic code when a malfunction has occurred, always inspect with the ignition and main switches on.

Should the power be cut, the diagnostic code will be erased from the computer memory.

- (c) Read the diagnostic code on the main switch indicator.

Indication Code		Diagnosis
	ON OFF	Normal.
11	ON OFF	Actuator circuit is abnormal.
21	ON OFF	Speed sensor signal circuit is abnormal.
23	ON OFF	*Vehicle speed decreases to 16 km/h (10 mph) or more below set speed.
31	ON OFF	Resume/accel switch circuit is abnormal.
*: If the set speed can be maintained when the speed control switch is again set at SET/COAST, there is no malfunction.		

NOTE:

- Indication codes appear in order from No. 11.
- Indication is stopped when vehicle speed is over 16 km/h (10 mph) or main switch is turned off.
- If there is no indication code, perform diagnosis and inspection. (See page BE-67)

Troubleshooting

Problem	Inspection Item		No.
Cruise control does not operate.	(a) Inspect type A codes.	No. 1 NO No. 2 NO No. 3 NO No. 4 NO No. 5 NO No. 6 NO	B C K F to J E E
	(b) Inspect type B codes.	11 21 23 31	D E D, E C
	(c) All codes are normal.		A, D, E
Vehicle speed fluctuates when set switch pushed on.	Inspect No. 1 of type A code.	OK NO	D B
Vehicle speed does not decrease when coast switch pushed on.			
Vehicle speed does not accelerate when accel switch pushed on.	Inspect No. 2 of type A code.	OK NO	D C
Vehicle speed does not return to memorized speed when resume switch pushed on.			
Setting speed deviates on high side.	_____	_____	D, E
Setting speed deviates on low side.			
Return and acceleration response is sluggish. (3S-GTE, 3S-GE w/ A.B.S.)	Inspect No. 3 of type A code.	OK NO	D K
Setting speed does not fluctuate when set switch pushed on.	Inspect No. 4 of type A code.	OK NO	D F
Setting speed does not cancel when brake pedal depressed.	Inspect No. 4 of type A code.	OK NO	D G
Setting speed does not cancel when parking brake lever pulled.	Inspect No. 4 of type A code.	OK NO	D H
Setting speed does not cancel when clutch pedal depressed (M/T only).	Inspect No. 4 of type A code.	OK NO	D I
Setting speed does not cancel when shifted to "N" range (A/T only).	Inspect No. 4 of type A code.	OK NO	D J
Speed can be set below about 40 km/h (25 mph).	Inspect No. 5 of type A code. Inspect No. 6 of type A code.	OK NO	D E
Cruise control will not disengage even about 40 km/h (25 mph).			
A short period after the O/D cut, (Approx. within 14 seconds) the O/D will resume.	_____	_____	L

A INSPECTION OF POWER SOURCE CIRCUIT

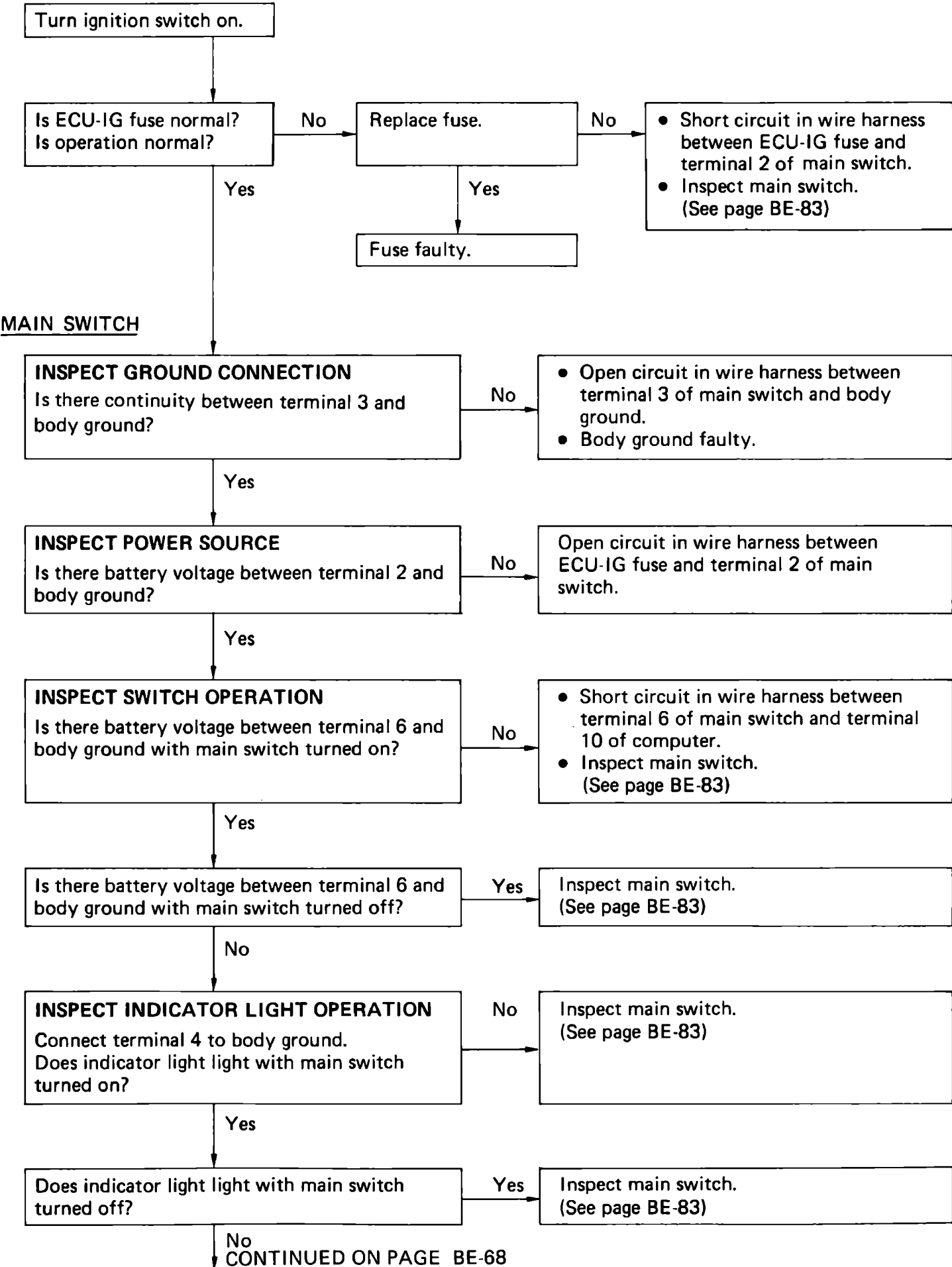

CONTINUED FROM PAGE BE-67

COMPUTER

Disconnect connector from computer and inspect connector on wire harness side as follows.

INSPECT GROUND CONNECTION
Is there continuity between terminal 13 and body ground?

No

- Open circuit in wire harness between terminal 13 and body ground.
- Body ground faulty.

Yes

INSPECT POWER SOURCE
Is there battery voltage between terminal 10 and body ground with main switch turned on?

No

Open circuit in wire harness between terminal 10 of computer and terminal 6 of main switch.

Yes

INSPECT INDICATOR LIGHT CIRCUIT
Connect terminal 3 to body ground. Does indicator light light with main switch turned on?

No

Open circuit in wire harness between terminal 3 of computer and terminal 4 of main switch.

Yes

Disconnect connector from main switch. Is there continuity between terminal 3 and body ground?

Yes

Short circuit in wire harness between terminal 3 of computer and terminal 4 of main switch.

No

Replace computer.

B INSPECTION OF SET/COAST SWITCH CIRCUIT

Turn ignition switch off.

CONTROL SW

INSPECT GROUND CONNECTION
 Disconnect connector from control switch.
 Is there continuity between terminal 2 of wire harness side connector and body ground?

No

- Open circuit in wire harness between terminal 2 and body ground.
- Body ground faulty.

Yes

INSPECT SET/COAST SWITCH OPERATION
 Is set/coast switch operation normal?
 (See page BE-83)

No

Replace control switch.

Yes

Connect connector to control switch.

COMPUTER

Disconnect connector from computer and inspect connector on wire harness side as follows.

INSPECT SET/COAST SWITCH CIRCUIT
 Is resistance value about 198 ohm between terminal 17 and body ground with set/coast switch pushed on?

No

Open or short circuit in wire harness between terminal 17 of computer and terminal 1 of control switch.

Yes

Replace computer.

C INSPECTION OF RESUME/ACCEL SWITCH CIRCUIT

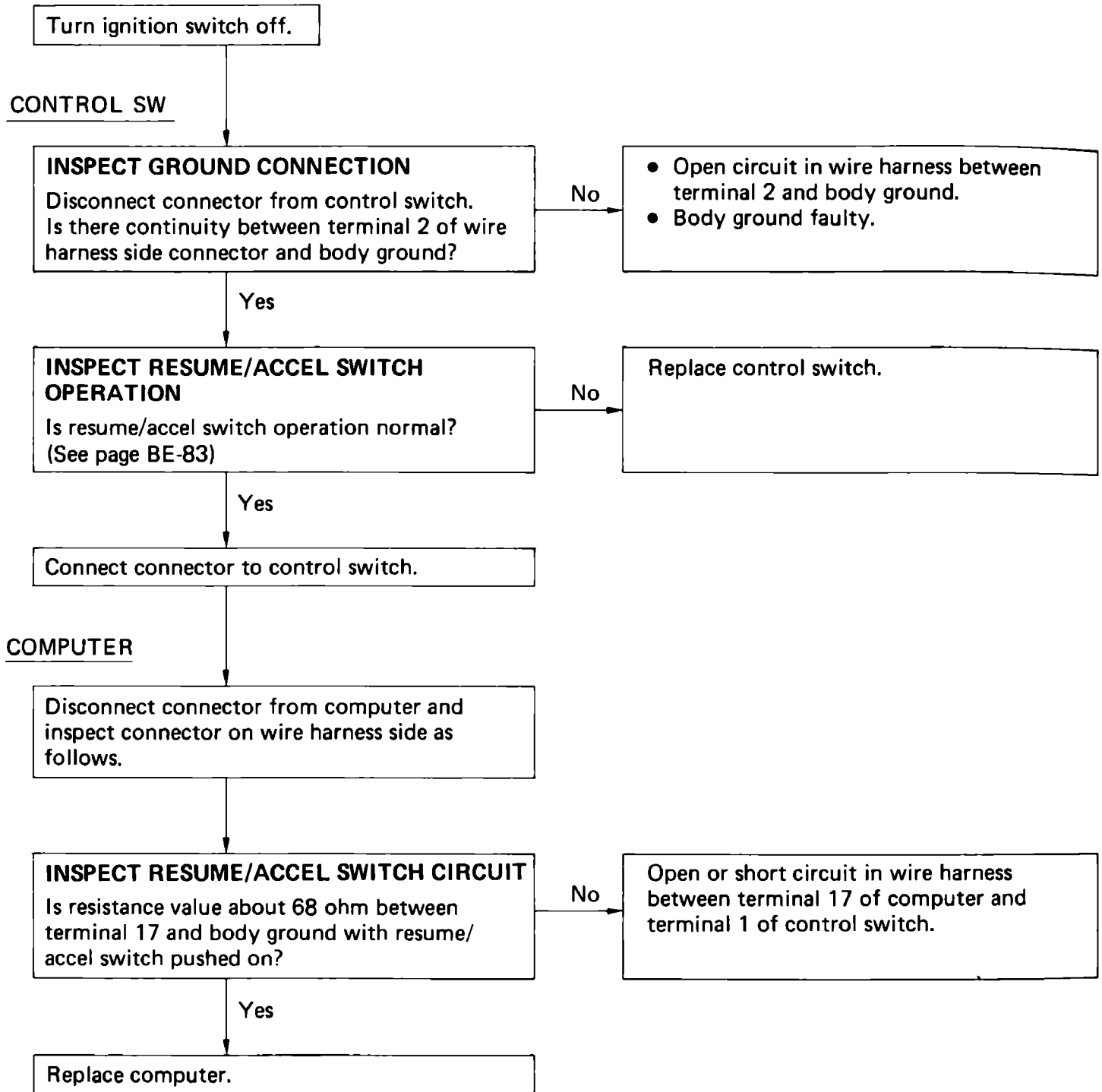

D INSPECTION OF ACTUATOR CIRCUIT

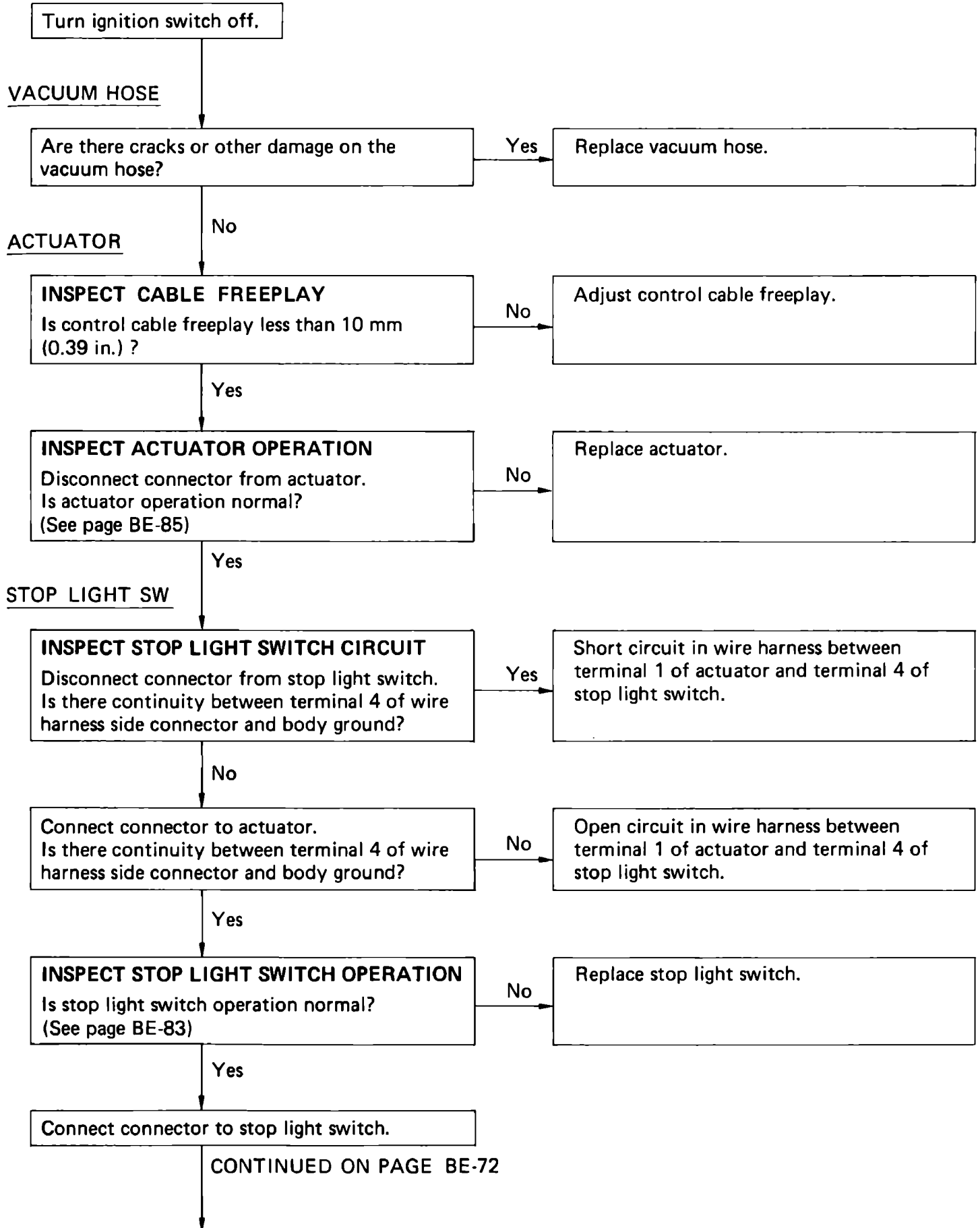

CONTINUED FROM PAGE BE-71

COMPUTER

Disconnect connector from computer and inspect connector on wire harness side as follows.

INSPECT STOP LIGHT SWITCH CIRCUIT
Is there continuity between terminals 2 and 14 with stop light switch released ?

No

Open circuit in wire harness between terminals 2 and 14 of computer.

Yes

Is there continuity between terminals 2 and 14 with stop light switch depressed?

Yes

Short circuit in wire harness between terminals 2 and 14 of computer.

No

Is there continuity between terminals 4 and 14?

No

Open circuit in wire harness between terminals 4 and 14 of computer.

Yes

Replace computer.

E INSPECTION OF SPEED SENSOR CIRCUIT

SPEEDOMETER CABLE

INSPECT SPEEDOMETER CABLE
Does the meter fluctuate when driving at a steady speed?

Yes

Meter cable faulty.

No

Turn ignition switch off.

SPEED SENSOR

INSPECT GROUND CONNECTION
Disconnect connector from meter (speed sensor).
Is there continuity between terminal 2 of wire harness side connector and body ground?

No

Open circuit in wire harness between terminal 2 and body ground.

Yes

INSPECT SPEED SENSOR OPERATION
Is speed sensor operation normal?
(See page BE-85)

No

Speed sensor faulty.

Yes

COMPUTER

INSPECT SPEED SENSOR CIRCUIT
Disconnect connector from computer.
Is there continuity between terminal 1 of wire harness side connector and terminal 7 of computer ?

No

Open circuit in wire harness between terminal 1 of speed sensor and terminal 7 of computer.

Yes

Replace computer.

F INSPECTION OF CANCEL SWITCH CIRCUIT

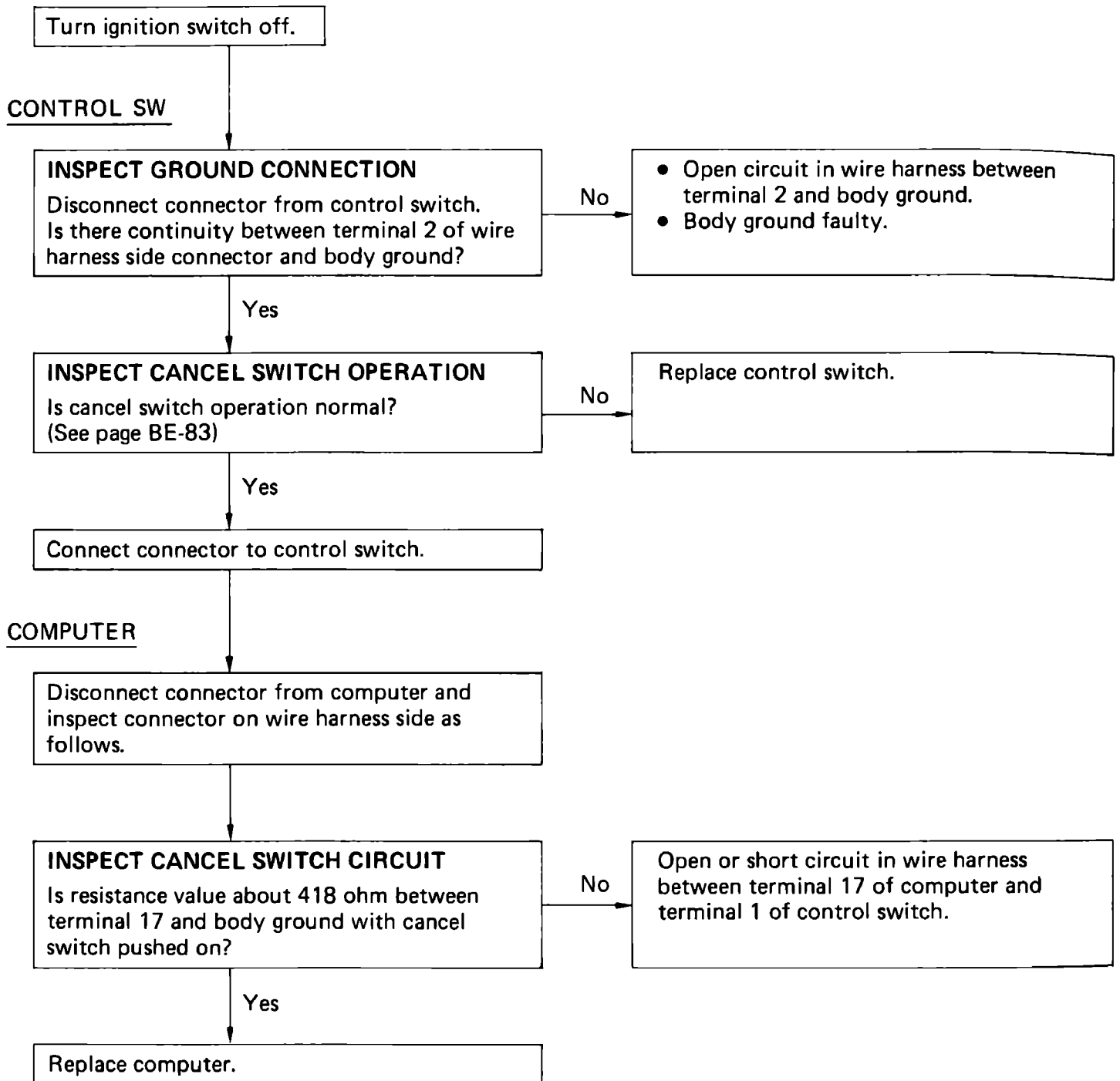

G INSPECTION OF STOP LIGHT SWITCH CIRCUIT

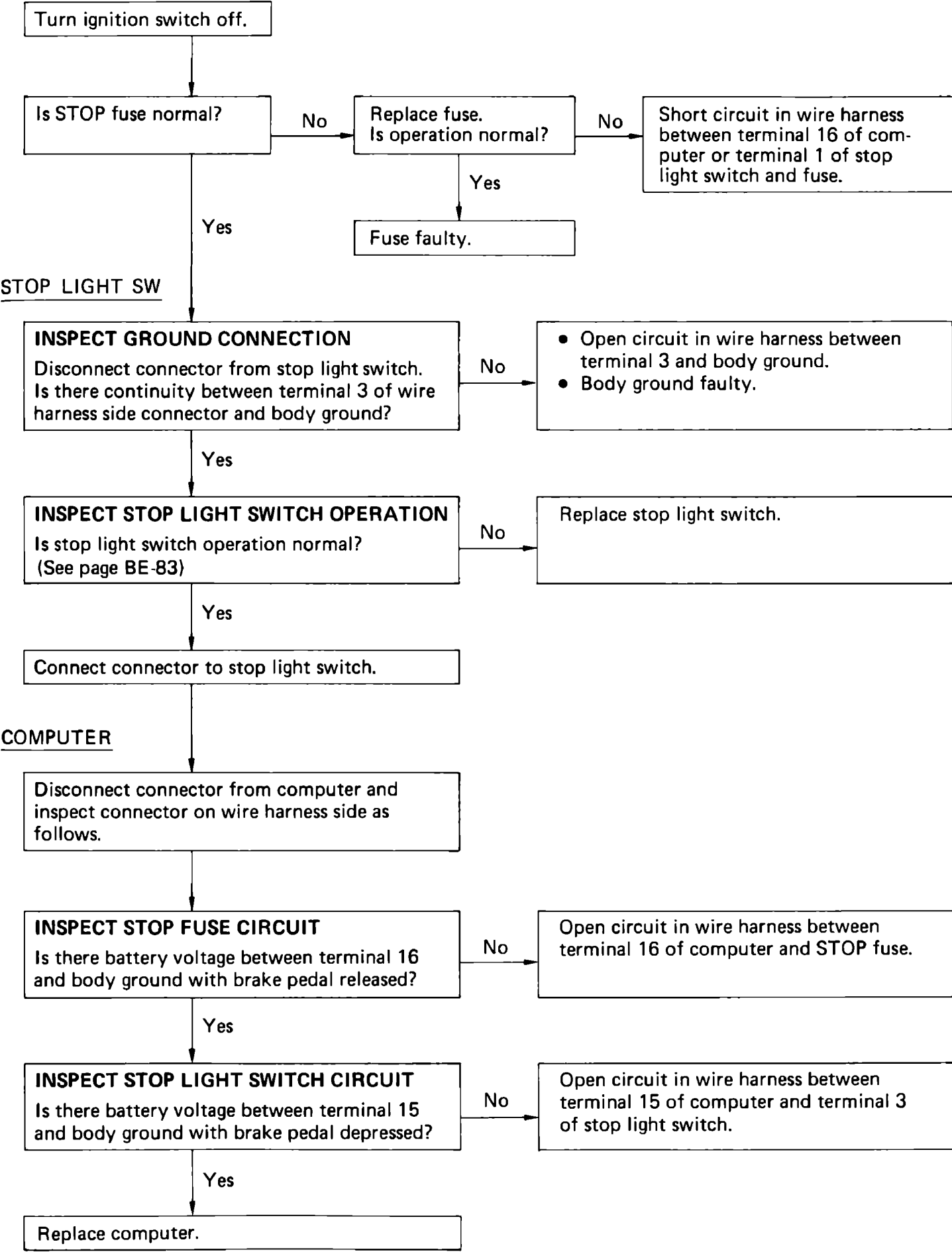

H INSPECTION OF PARKING BRAKE SWITCH CIRCUIT

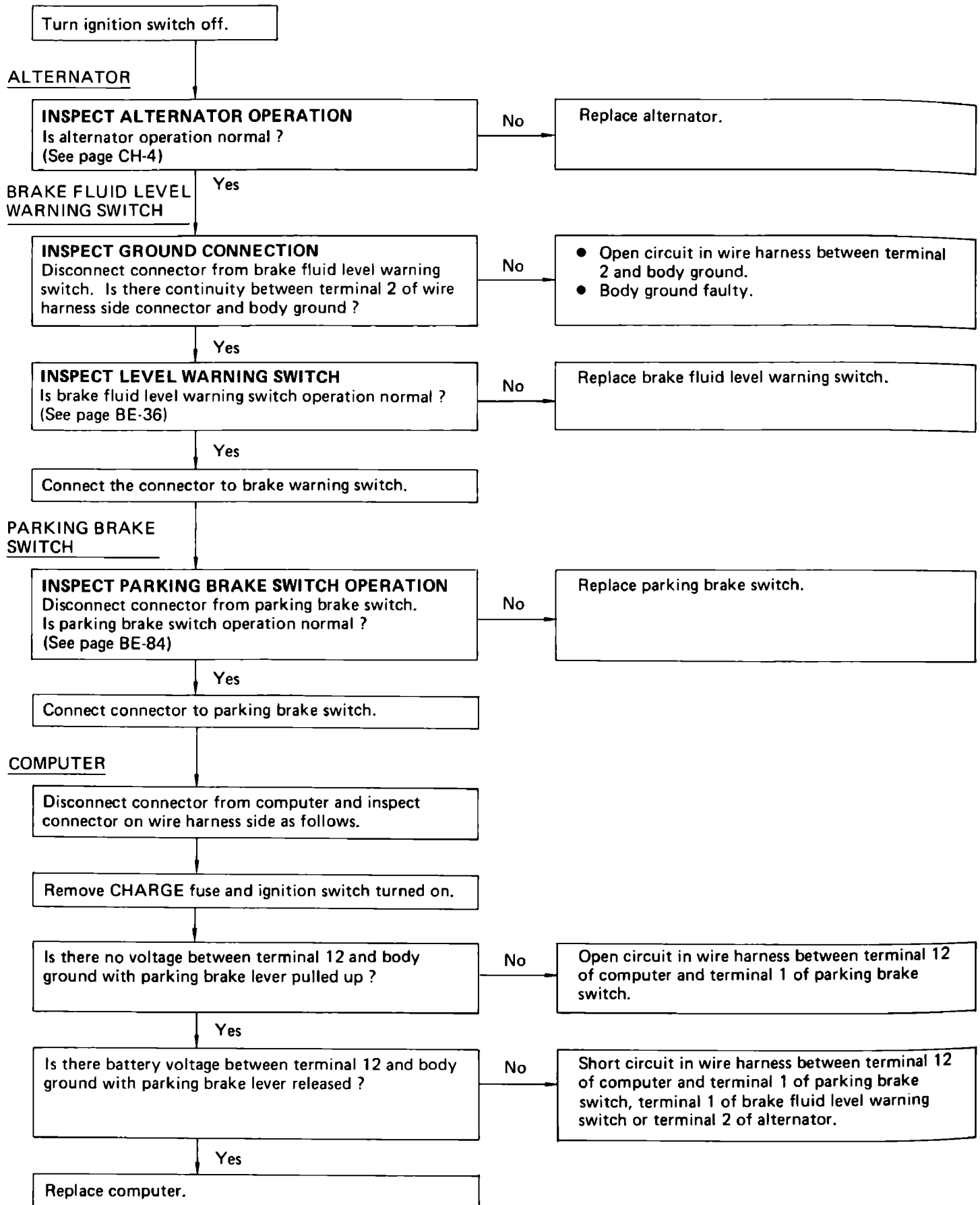

I INSPECTION OF CLUTCH SWITCH CIRCUIT

Turn ignition switch off.

CLUTCH SW

INSPECT GROUND CONNECTION
 Disconnect connector from clutch switch.
 Is there continuity between terminal 2 of wire harness side connector and body ground?

No

- Open circuit in wire harness between terminal 2 and body ground.
- Body ground faulty.

Yes

INSPECT CLUTCH SWITCH OPERATION
 Is clutch switch operation normal?
 (See page BE-84)

No

Replace clutch switch.

Yes

Connect connector to clutch switch.

COMPUTER

Disconnect connector from computer and inspect connector on wire harness side as follows.

INSPECT CLUTCH SWITCH CIRCUIT
 Is there continuity between terminal 11 and body ground with clutch pedal depressed?

No

Open circuit in wire harness between terminal 11 of computer and terminal 3 of clutch switch.

Yes

Is there continuity between terminal 11 and body ground with clutch pedal released?

Yes

Short circuit in wire harness between terminal 11 of computer and terminal 3 of clutch switch.

No

Replace computer.

J INSPECTION OF NEUTRAL START SWITCH CIRCUIT

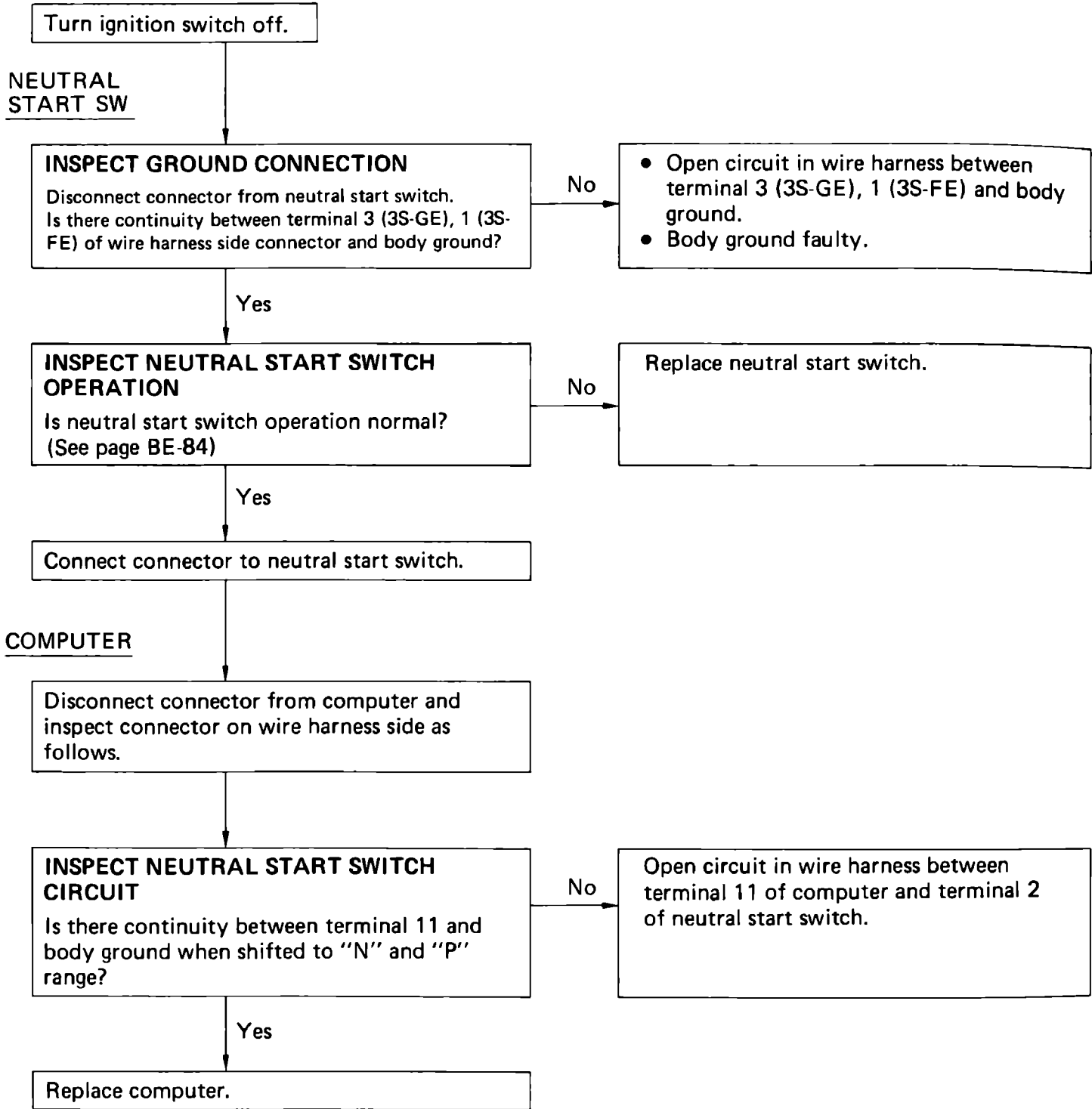

K INSPECTION OF VACUUM CIRCUIT (3S-GTE, 3S-GE w/A.B.S.)

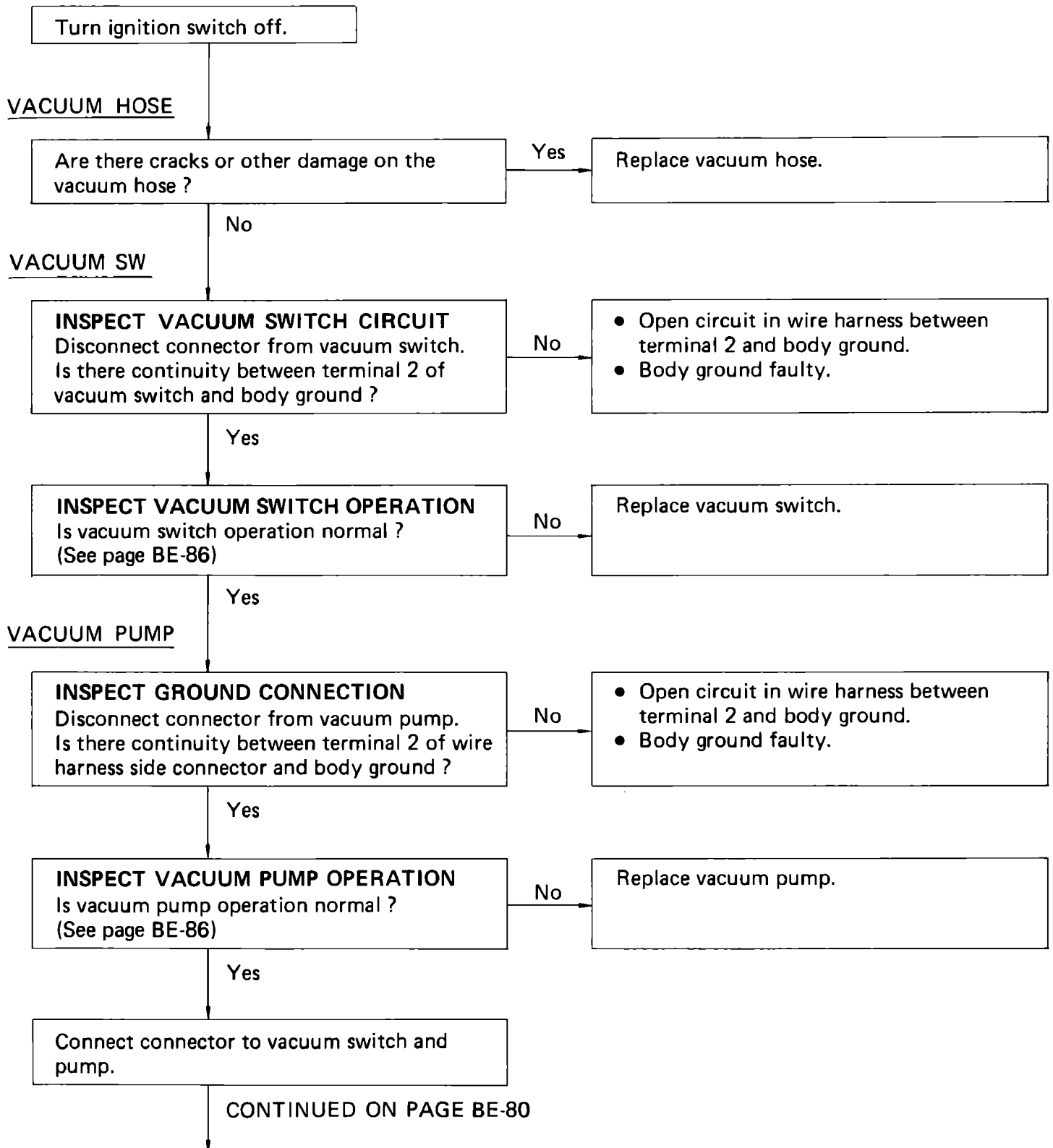

CONTINUED FROM PAGE BE-79

COMPUTER

Disconnect connector from computer and inspect connector on wire harness side as follows.

INSPECT VACUUM SWITCH CIRCUIT
Is there continuity between terminal 9 and body ground ?

No

Open circuit in wire harness between terminal 9 of computer and terminal 1 of vacuum switch.

Yes

Start engine (idling).

Is there continuity between terminal 9 and body ground ?

Yes

Short circuit in wire harness between terminal 9 of computer and terminal 1 of vacuum switch.

No

Stop the engine.

INSPECT VACUUM PUMP CIRCUIT
Is there continuity between terminal 1 and body ground ?

No

Open circuit in wire harness between terminal 1 of computer and terminal 1 of vacuum pump.

Yes

Is there continuity between terminal 1 and body ground when disconnect connector from vacuum pump ?

Yes

Short circuit in wire harness between terminal 1 of computer and terminal 1 of vacuum pump.

No

Replace computer.

L INSPECTION OF ECT SOLENOID CIRCUIT

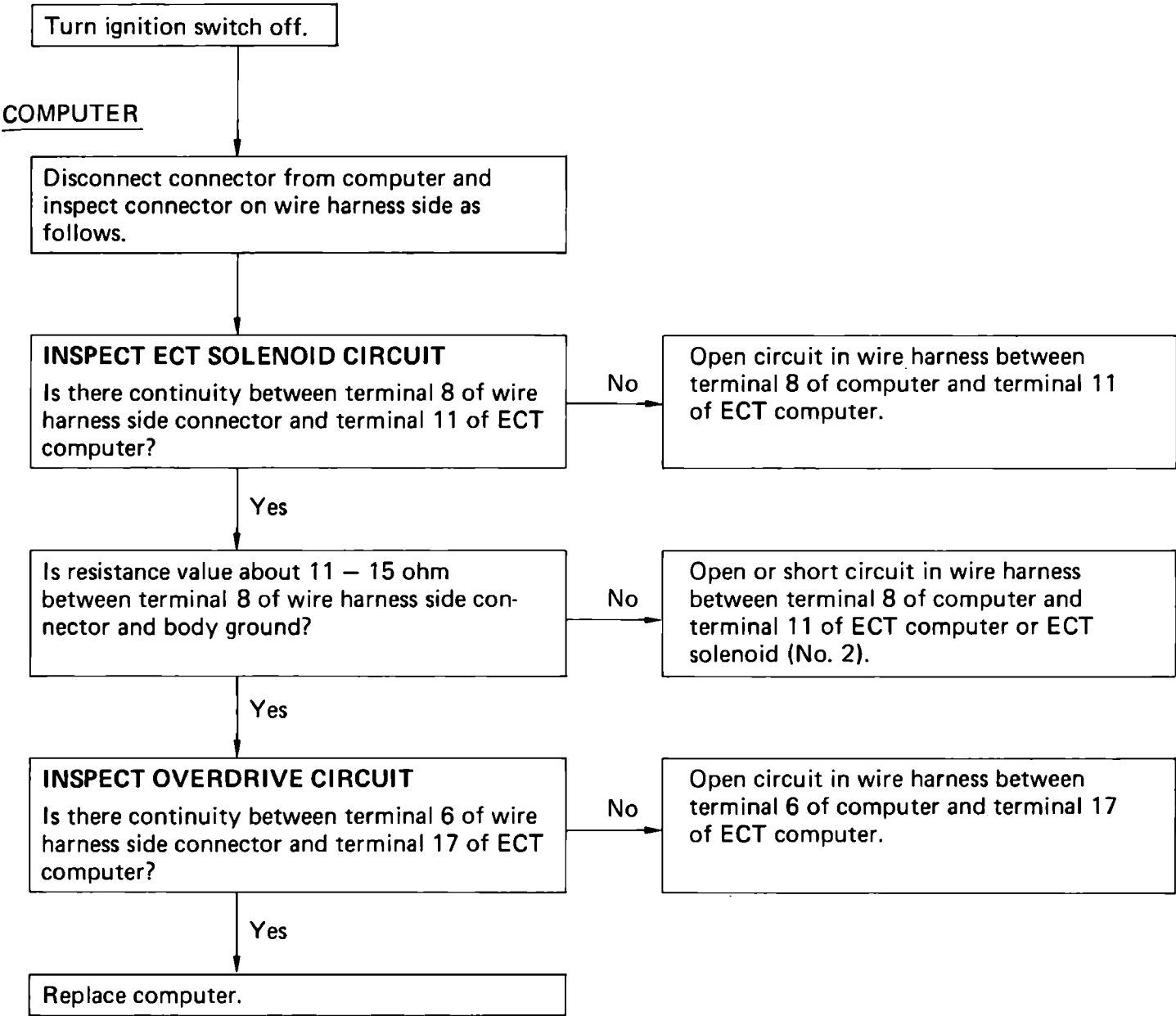

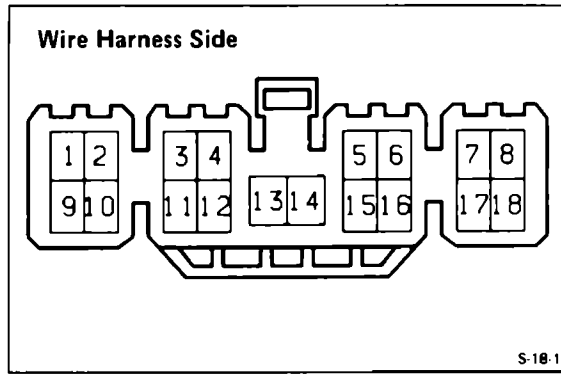

Cruise Control Computer Circuit

INSPECTION OF COMPUTER CIRCUIT

Disconnect the computer connector and inspect the connector on wire harness side as shown in the below.

Connection or measure item	Check for	Tester connection	Condition	Specified value
Stop Fuse	Voltage	16 – Body ground	—	Battery voltage
Stop Light Switch	Voltage	15 – Body ground	Brake pedal depressed	Battery voltage
			Brake pedal released	No voltage
Stop Light Switch and Release Valve	Resistance	2 – 14	Brake pedal released	Approx. 68 ohm
Control Valve	Resistance	4 – 14	—	Approx. 30 ohm
Main Switch	Voltage	10 – Body ground	Turn ignition switch and main switch on	Battery voltage
			Turn ignition switch and main switch off	No voltage
Main Switch (indicator circuit)	Voltage	3 – Body ground	Turn ignition switch and main switch on	Battery voltage
			Turn ignition switch and main switch off	No voltage
Control Switch (set/coast)	Resistance	17 – Body ground	Push set/coast switch on	Approx. 198 ohm
Control Switch (resume/accel)	Resistance	17 – Body ground	Push resume/accel switch on	Approx. 68 ohm
Control Switch (cancel)	Resistance	17 – Body ground	Push cancel switch on	Approx. 418 ohm
Speed Sensor	Continuity	7 – Body ground	Vehicle moving slowly	1 pulse each 40 cm (15.75 in.)
Clutch Switch (M/T) or Neutral Start Switch (A/T)	Continuity	11 – Body ground	Clutch pedal depressed or shifted into "N" and "P" range	Continuity
			Clutch pedal released or shifted into only range except "N" range	No continuity
Parking Brake Switch	Voltage	12 – Body ground	Remove CHARGE fuse and ignition switch turned on with parking brake lever pulled up.	No voltage
			Remove CHARGE fuse and ignition switch turned on with parking brake lever released.	Battery voltage
Vacuum Switch (3S-GTE, 3S-GE w/ A.B.S.)	Continuity	9 – Body ground	Apply vacuum about 170 mmHg (6.69 in.Hg, 22.7 kPa)	No continuity
			No vacuum	Continuity
Vacuum Pump (3S-GTE, 3S-GE w/ A.B.S.)	Continuity	1 – Body ground	—	Continuity
Body Ground	Continuity	13 – Body ground	—	Continuity

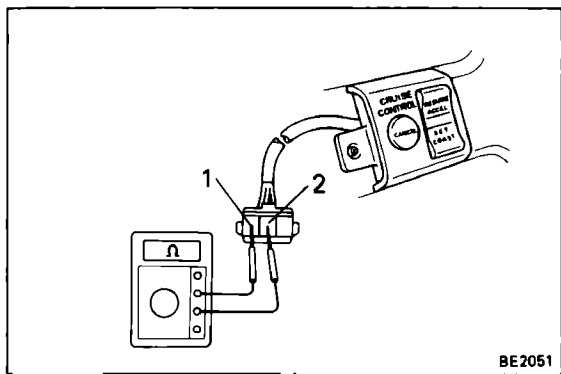
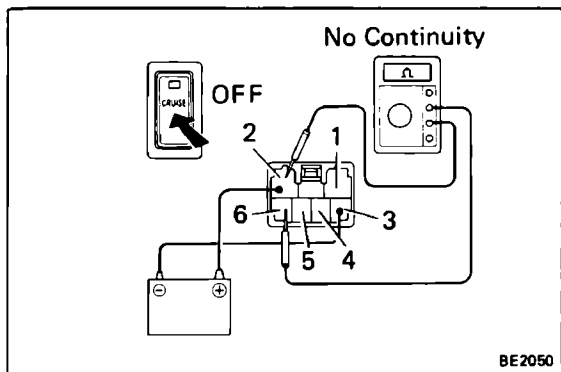
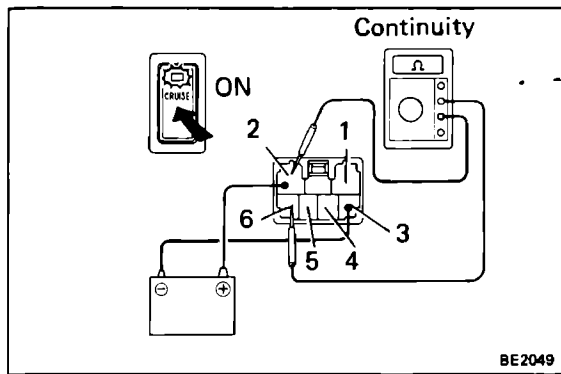

Main Switch

INSPECTION OF MAIN SWITCH

INSPECT SWITCH CONTINUITY

- (a) Connect the positive (+) lead from the battery to terminal 2 and the negative (-) lead to terminal 3.
- (b) Check that there is continuity between terminals 2 and 6 with the main switch pushed on.

- (c) Check that there is no continuity between terminals 2 and 6 with the main switch pushed off.

If continuity is not as specified, replace the switch.

Control Switch

INSPECTION OF SWITCH

INSPECT SWITCH RESISTANCE

Inspect the switch resistance value between terminals 1 and 2 at each switch position.

Switch position	Resistance value (Ω)
RESUME/ACCEL	68
SET/COAST	198
CENCEL	418

If resistance value is not as specified, replace the switch.

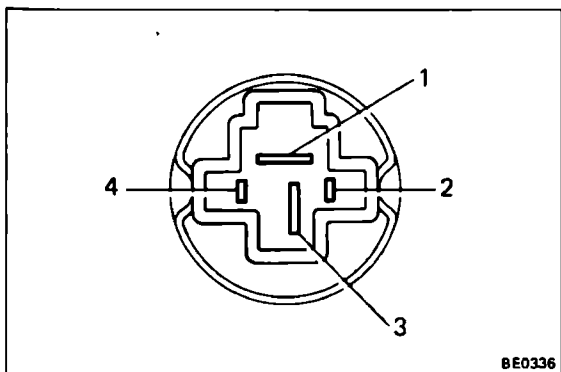

Stop Light Switch

INSPECTION OF SWITCH

INSPECT SWITCH CONTINUITY

Inspect the switch continuity between terminals.

Terminal	1	2	3	4
Switch position				
Switch free	○	○		
Switch Pin pushed		○	○	○

If continuity is not as specified, replace the switch.

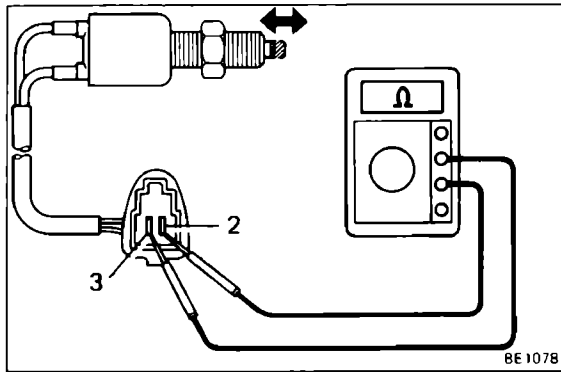

Clutch Switch

INSPECTION OF SWITCH

INSPECT SWITCH CONTINUITY

- (a) Check that there is continuity between terminals 2 and 3 with the switch free.
(Clutch pedal depressed)
- (b) Check that there is no continuity between terminals 2 and 3 with switch pin pushed.
(Clutch pedal released)

If continuity is not as specified, replace the switch.

Parking Brake Switch

INSPECTION OF SWITCH

INSPECT SWITCH OPERATION

- (a) Check that there is continuity between terminal and screw hole with the switch free.
(Parking brake lever pulled up)
- (b) Check that there is no continuity between terminal and screw hole with the switch pin pushed.
(Parking brake lever released)

If operation is not as specified, replace the switch.

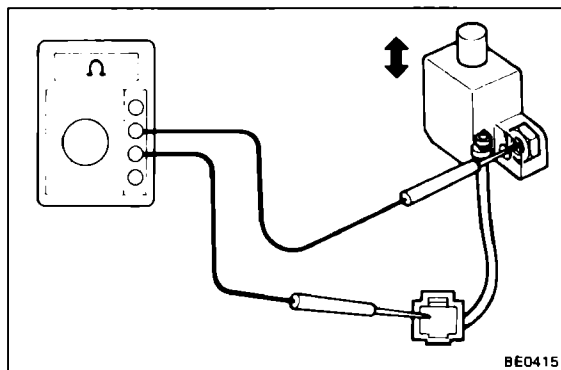

3S-FE Engine

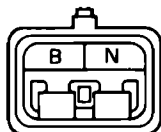

3S-GE Engine



Neutral Start Switch

INSPECTION OF SWITCH

INSPECT SWITCH CONTINUITY

Check that there is continuity between terminals B and N with switch position "P" and "N" ranges.

If continuity is not as specified, replace the switch.

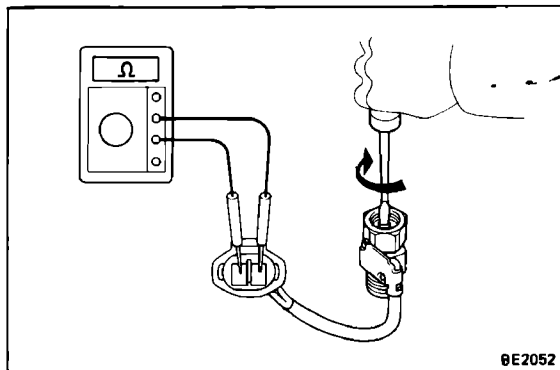

8E2052

Speed Sensor

INSPECTION OF SPEED SENSOR

INSPECT SENSOR CONTINUITY

Check that there is continuity between terminals four times per each revolution of the shaft.

If continuity is not as specified, replace the sensor.

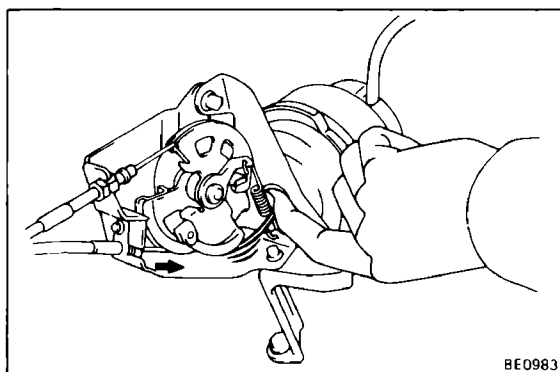

8E0983

Actuator

INSPECTION OF ACTUATOR

1. INSPECT CONTROL CABLE FREEPLAY

Inspect that the control cable freeplay is less than 10 mm (0.39 in.)

If freeplay is not as specified, adjust the control cable freeplay.

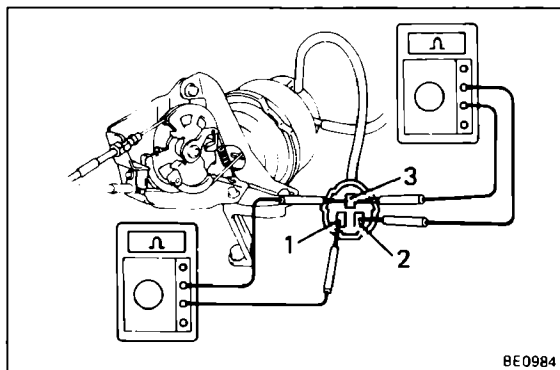

8E0984

2. INSPECT ACTUATOR RESISTANCE

Measure the resistance value between terminals as follows.

Resistance: 2 – 3 approx. 30 Ω

1 – 3 approx. 68 Ω

If the resistance value is not as specified, replace the actuator.

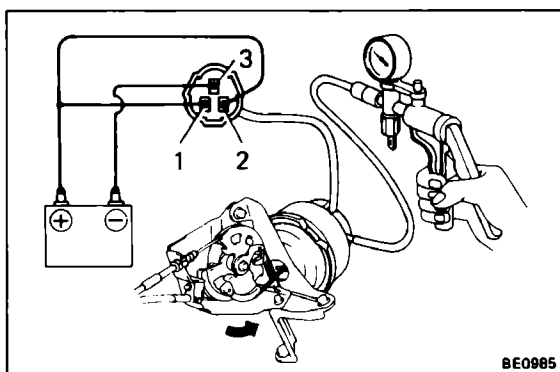

8E0985

3. INSPECT ACTUATOR OPERATION

(a) Connect the positive (+) lead from battery to terminals 1 and 2, and the negative (-) lead to terminal 3.

(b) Slowly apply vacuum from 0 – 300 mmHg (0 – 11.81 in.Hg, 0 – 40.0 kPa), and check that the control cable can be pulled smoothly.

(c) Disconnect terminal 1 or 2 and check that the control cable returns to its original position and the vacuum returns to 0 mmHg (0 in.Hg, 0 kPa).

If operation is not as specified, replace the actuator.

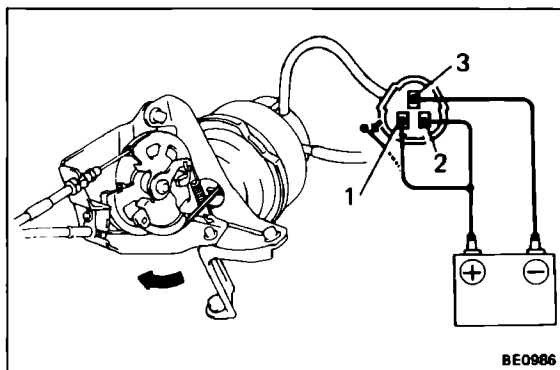

8E0986

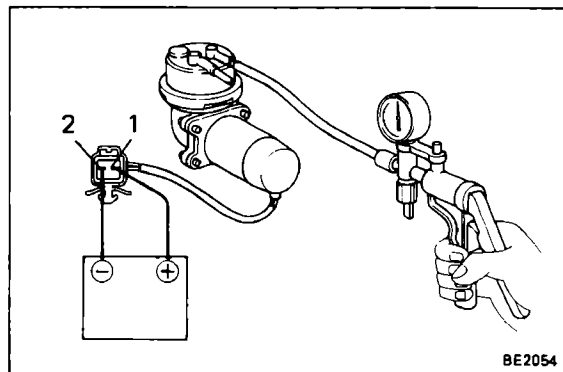
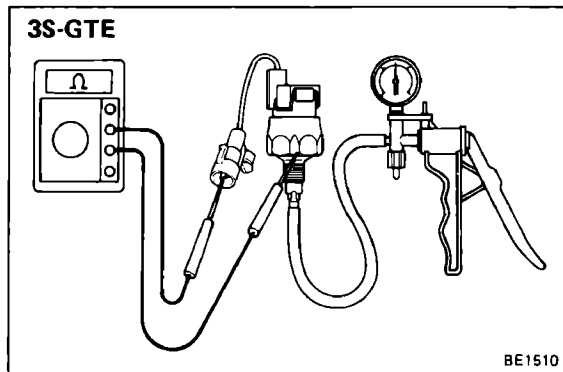
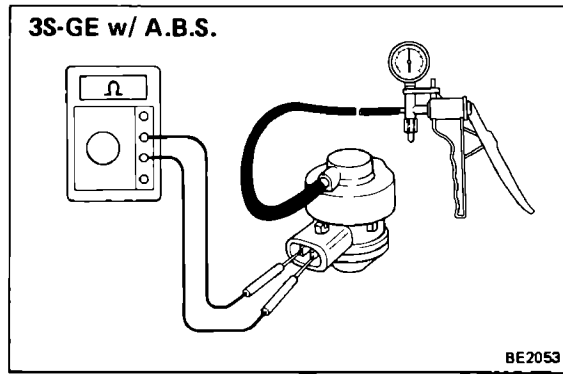

Vacuum Switch

(3S-GTE, 3S-GE w/A.B.S.)

INSPECTION OF SWITCH

INSPECT SWITCH OPERATION

- Check that there is no continuity between terminals with a vacuum of 170 ± 10 mmHg (6.69 ± 0.39 in.Hg, 22.7 ± 1.3 kPa) or above.
- Check that there is continuity between terminals with no vacuum.

If operation is not as specified, replace the switch.

Vacuum Pump

(3S-GTE, 3S-GE w/A.B.S.)

INSPECTION OF PUMP

INSPECT VACUUM PUMP OPERATION

- Connect a vacuum gauge to the ACT side of the pump.
- Connect the positive (+) lead from the battery to terminal 1 and the negative (–) lead to terminal 2.
- Check that there is the vacuum of 200 mmHg (7.87 in.Hg, 26.7 kPa) or above.

If operation is not as specified, replace the pump.

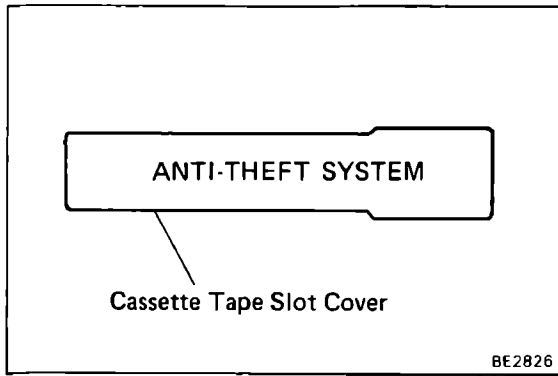

AUDIO SYSTEM

System Description

Anti-Theft System (USA only)

The anti-theft system is only provided for audio systems equipped with an Acoustic Flavor function.

NOTE: The words "ANTI-THEFT SYSTEM" are displayed on the cassette tape slot cover.

For operation instructions for the anti-theft system, please consult the audio system section in the Owner's Manual (hereafter called O/M).

1. SETTING SYSTEM

The system is in operation once the customer has pushed the required buttons and entered the customer-selected 3-digit ID number.

(Refer to the O/M section, "Setting the anti-theft system")

NOTE:

- When the audio system is shipped the ID number has not been input, so the anti-theft system is not in operation.
- If the ID number has not been input, the audio system remains the same as a normal audio system.

2. ANTI-THEFT SYSTEM OPERATION

If the normal electrical power source (connector or battery terminal) is cut off, the audio system becomes inoperable, even if the power supply resumes.

3. CANCELLING SYSTEM

The ID number chosen by the customer is input to cancel the anti-theft system.

(Refer to the O/M section, "If the system is activated")

NOTE: To change or cancel the ID number, please refer to the O/M section, "Cancelling the system".

Troubleshooting

NOTE: For audio systems with anti-theft system, troubleshooting items marked (*) indicate that "Troubleshooting for ANTI-THEFT SYSTEM" should be carried out first.

No.	Problem	
1.	DEAD RADIO AND TAPE PLAYER	* (a) No power to radio or tape player, or power but no sound.
		(b) Tape player okay but no sound from AM and FM or either one.
		(c) No sound from one speaker.
2.	FAINT RECEPTION	—
3.	BAD SOUND QUALITY	(a) Sound quality bad when radio played.
		(b) Sound quality bad when tape player played.
4.	DEFECTIVE AUTO-SEARCH MACHANISM	—
Troubleshooting for CD player		See page BE-95

Troubleshooting for ANTI-THEFT SYSTEM

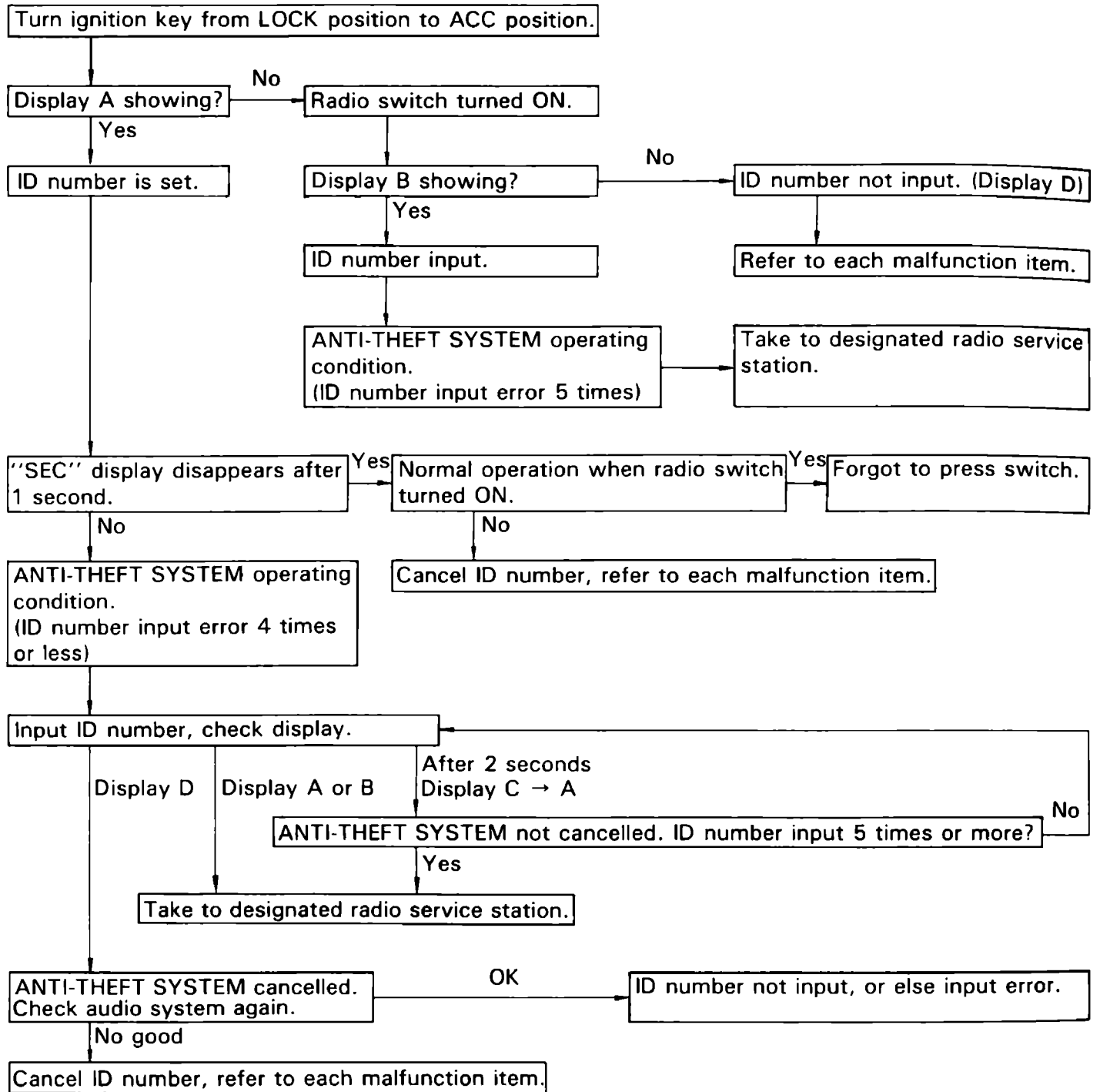

(Liquid Crystal Display (LCD) for Audio System)

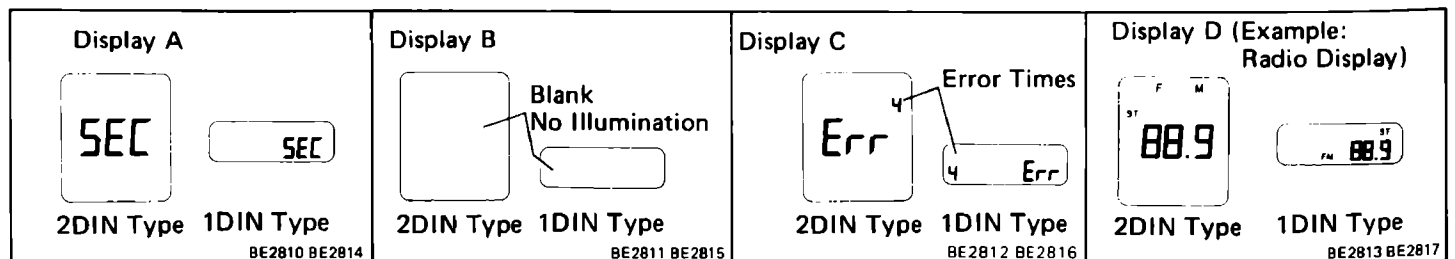

NOTE:

- Refer to O/M for operation details of ANTI-THEFT SYSTEM.
- When the ID number has been cancelled, reset the same number after completing the operation, or inform the customer that it has been cancelled.

DESCRIPTION OF SYMBOLS

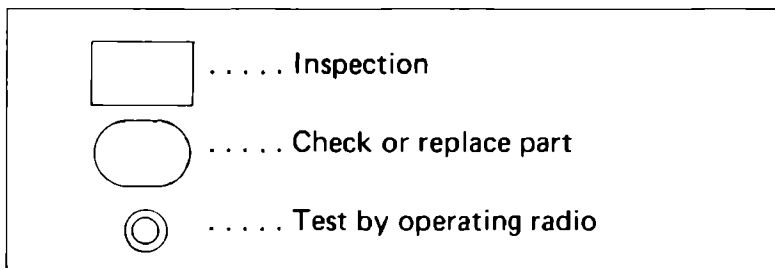

1. DEAD RADIO AND TAPE PLAYER

(a) No power to radio or tape player, or power but no sound.

Possible causes:

- Blown DOME fuse
- Short circuit or broken wire in power source wire harness
- Loose connectors behind radio and tape player
- Loose speaker connector
- Defective speaker
- Broken wire in speaker wire harness
- Improperly installed radio or tape player
- Defective radio or tape player

TEST 1

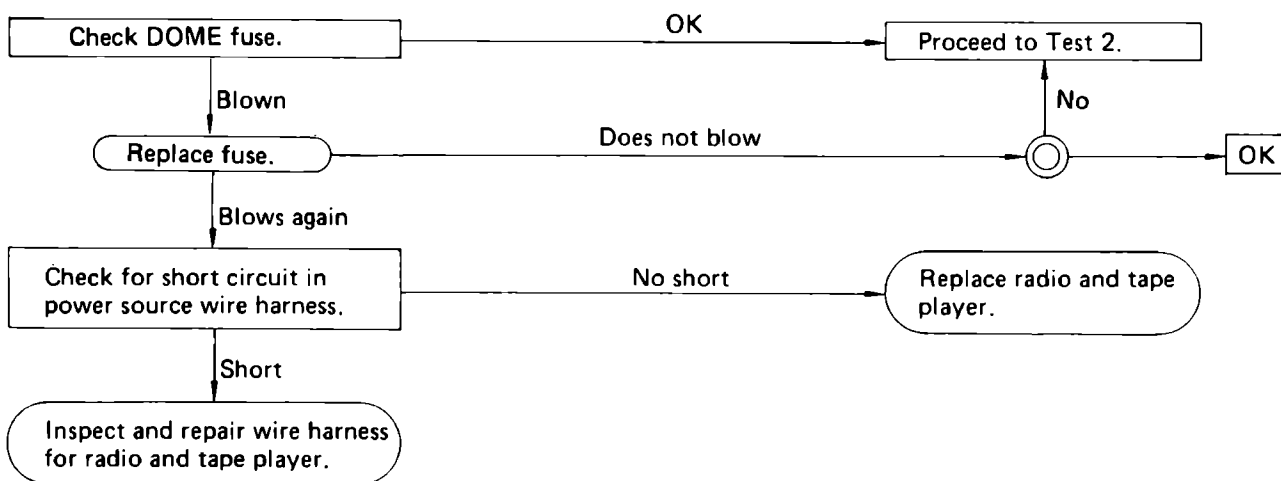

TEST 2

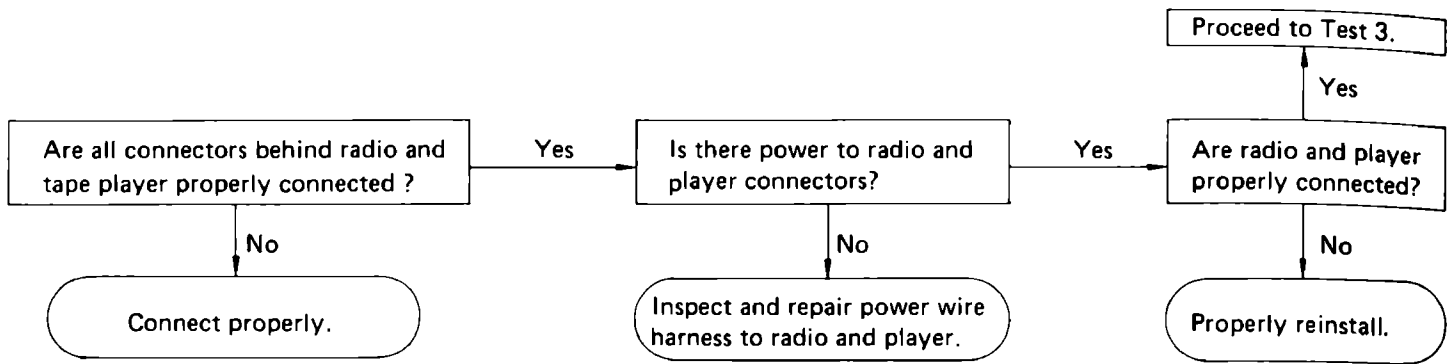

TEST 3

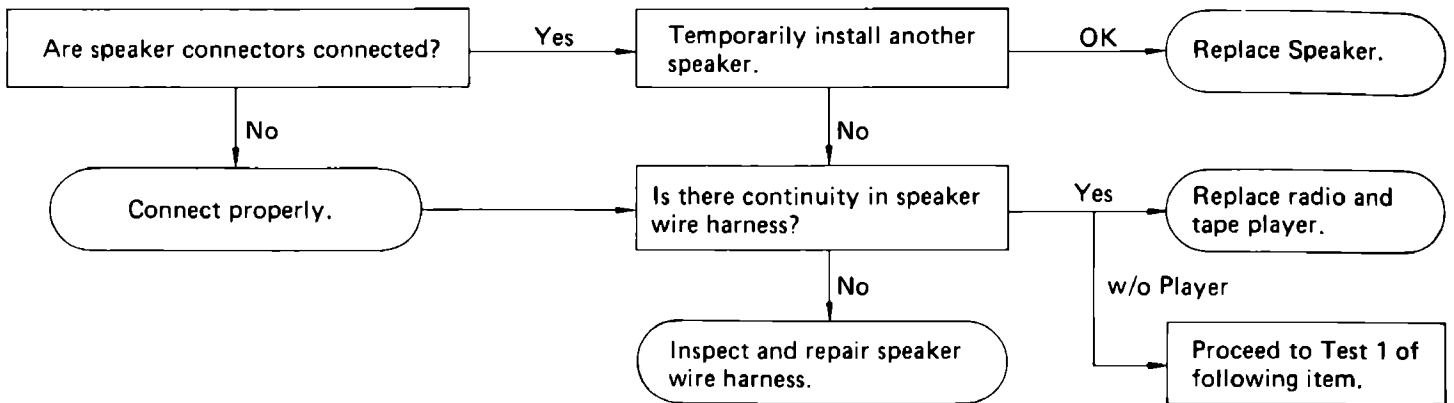

(b) Tape player okay but no sound from either the AM or FM band.

Possible causes:

- Antenna disconnected
- Antenna plug not properly connected
- Defective antenna
- Defective antenna cable
- Defective radio or tape player
- Blown RADIO fuse
- Short circuit or broken wire in wire harness for back-up power source

TEST 1

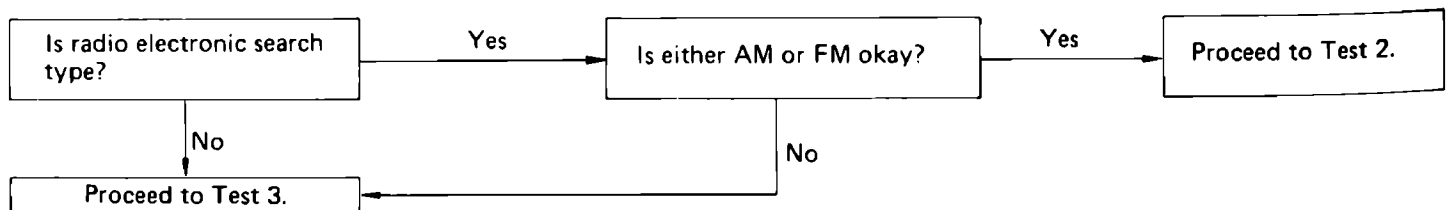

TEST 2

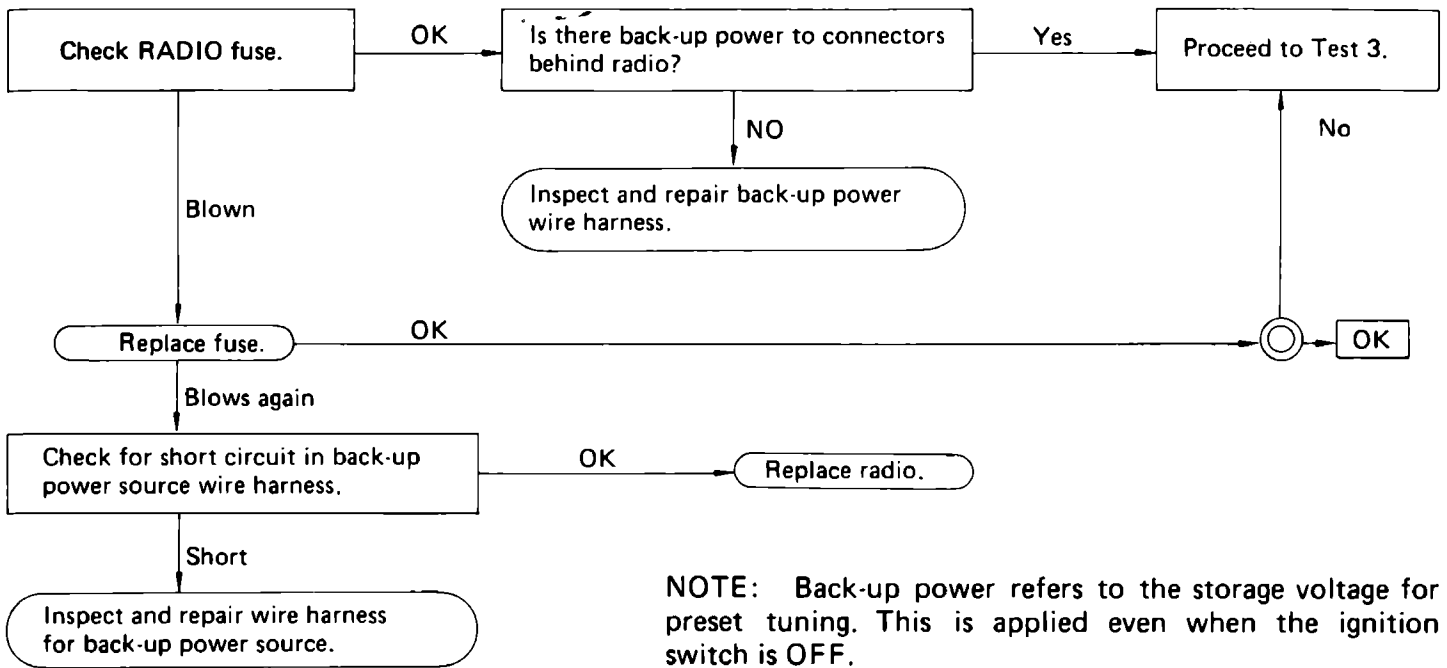

TEST 3

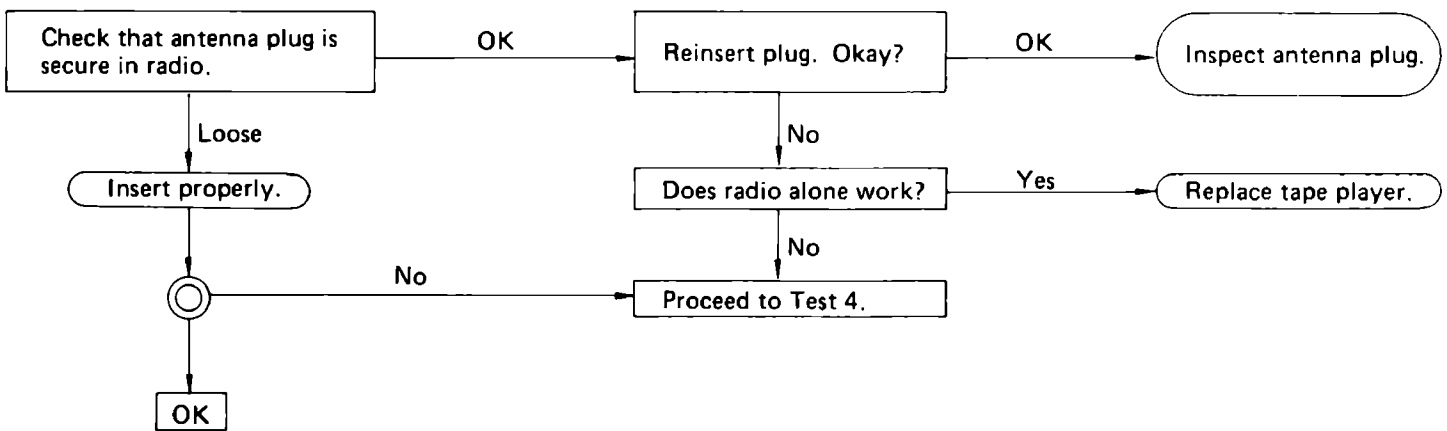

TEST 4

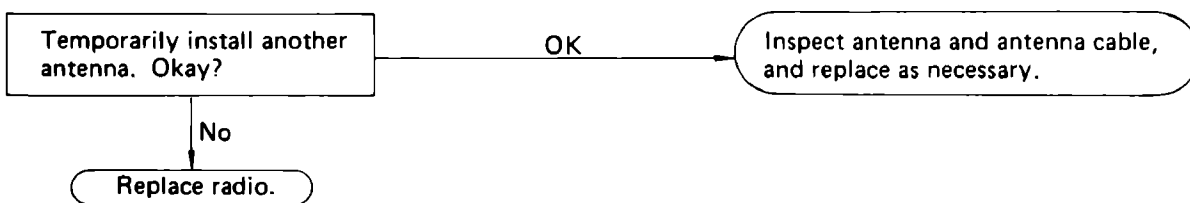

(c) No sound from one speaker.

Possible causes:

- Loose speaker connector
- Broken wire in speaker wire harness
- Defective speaker
- Defective radio and tape player

TEST 1

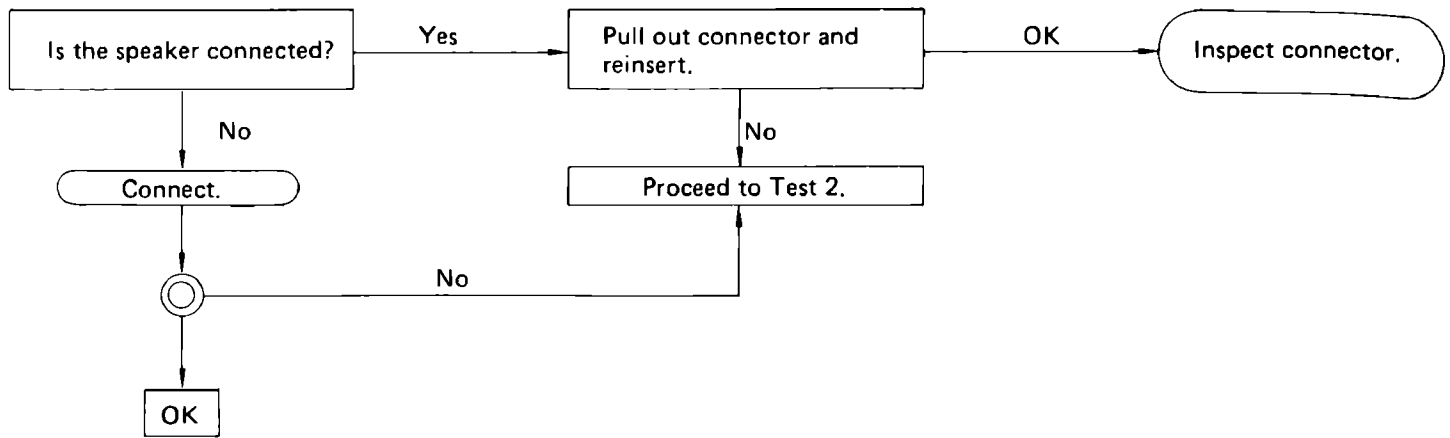

TEST 2

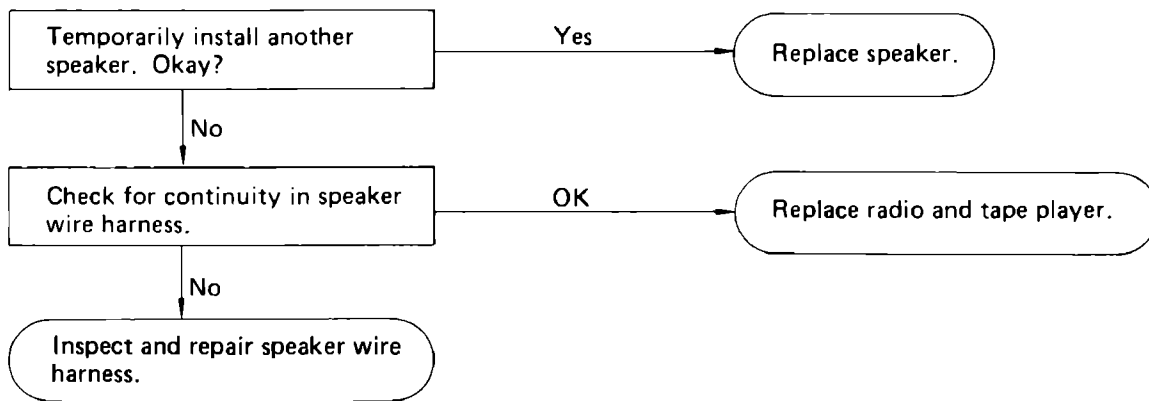

2. FAINT RECEPTION

Possible causes:

- Defective antenna or antenna cable
- Defective speaker
- Defective radio

TEST

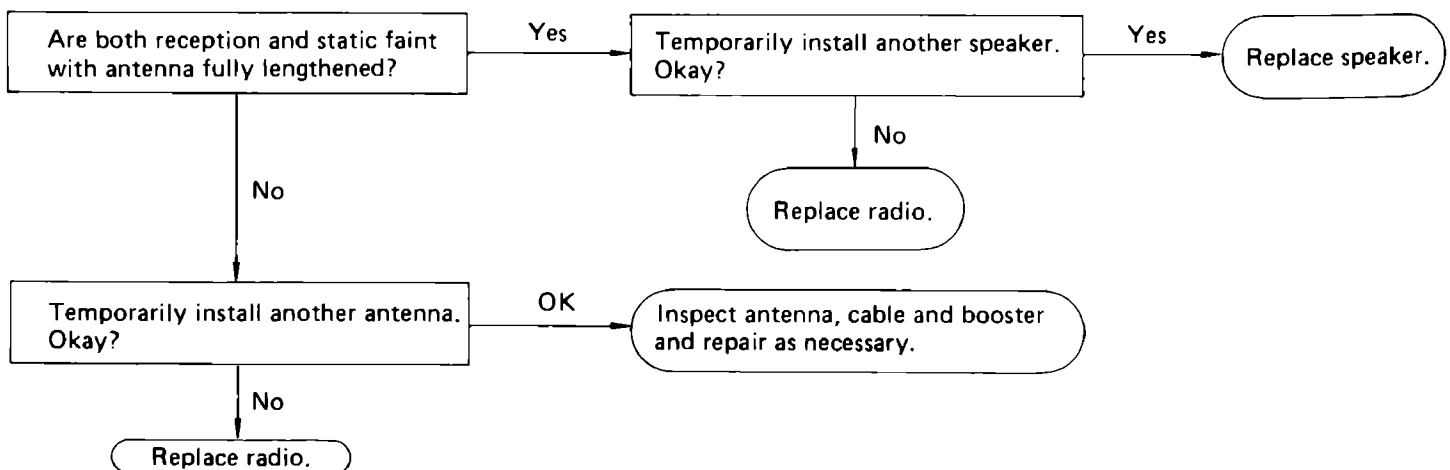

3. BAD SOUND QUALITY

(a) Sound quality bad when radio played.

Possible causes:

- Multipath interference of excessive interception
- Tuner dial not synchronized with station
- Defective antenna or antenna cable
- Speaker improperly installed
- Vibration sound from components near speaker
- Defective speaker
- Defective radio

TEST 1

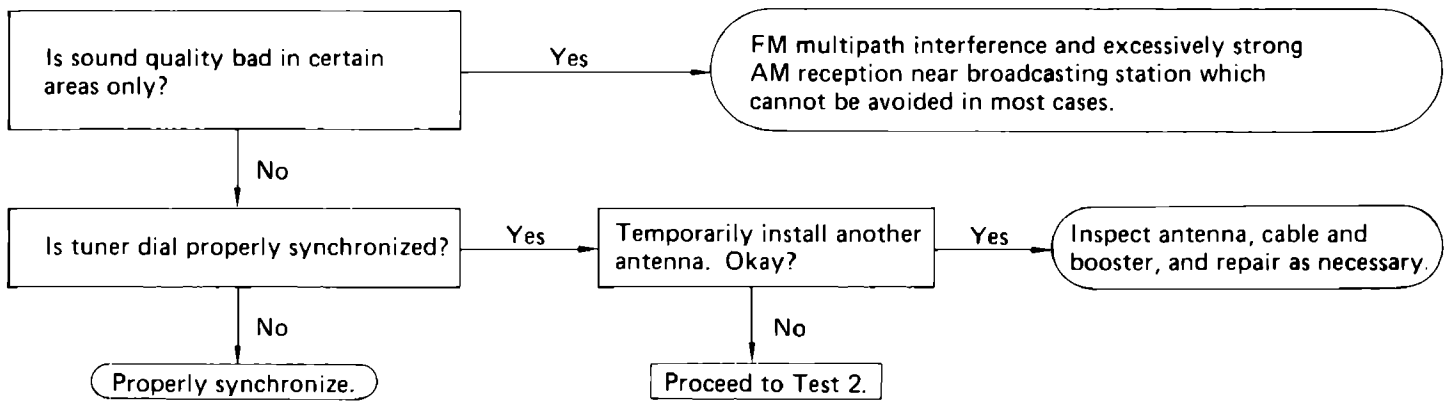

TEST 2

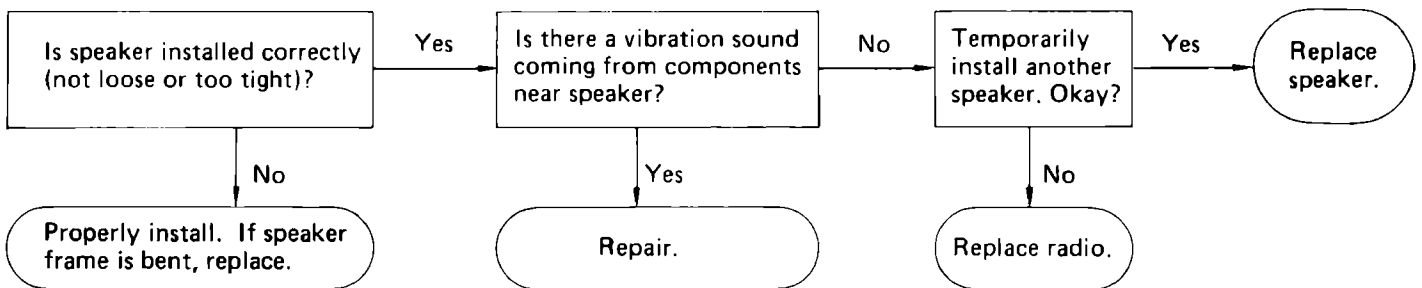

NOTE: FM distortion tends to increase sharply if the tuner is not synchronized.

(b) Sound quality bad when tape player played.

Possible causes:

- Bad tape
- Dirty head
- Incorrectly installed speaker
- Vibration noise from around speaker
- Defective speaker
- Defective tape player

TEST 1

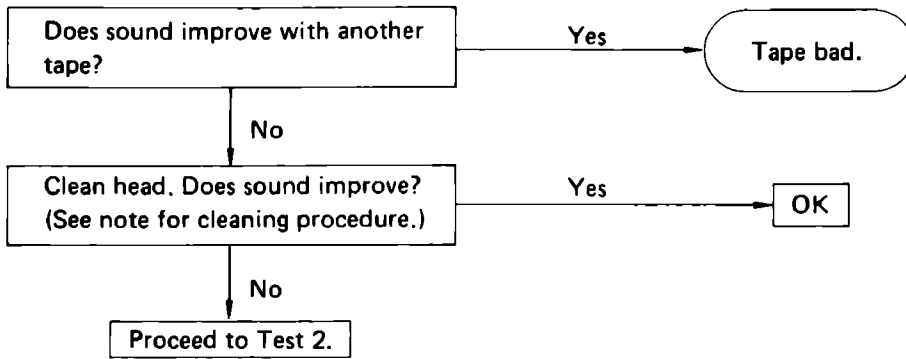

TEST 2

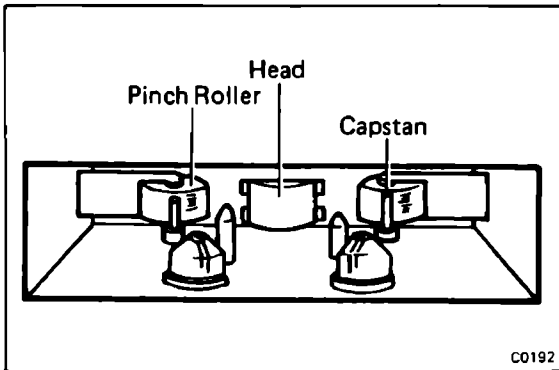
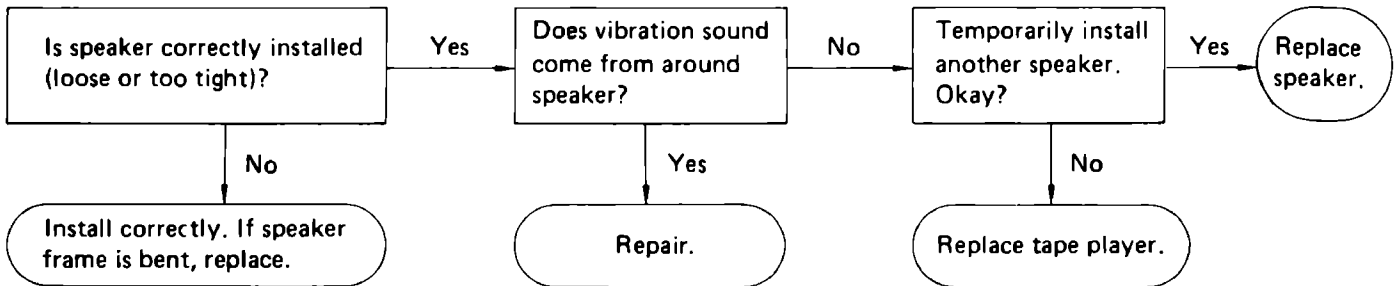

NOTE: Head cleaning procedure.

- (1) Raise the cassette door with your finger. Next, using a pencil or like object, push in the guide as shown.
- (2) Using a cleaning pen or cotton applicator soaked in alcohol, clean the head surface, pinch rollers and capstans.
- (3) Push in the "eject" button.

4. DEFECTIVE AUTO-SEARCH MECHANISM

Manual search possible but automatic search mechanism does not function or does not stop at all receivable stations.

Possible causes:

- Poor search sensitivity (SENS button)
- Defective radio

TEST

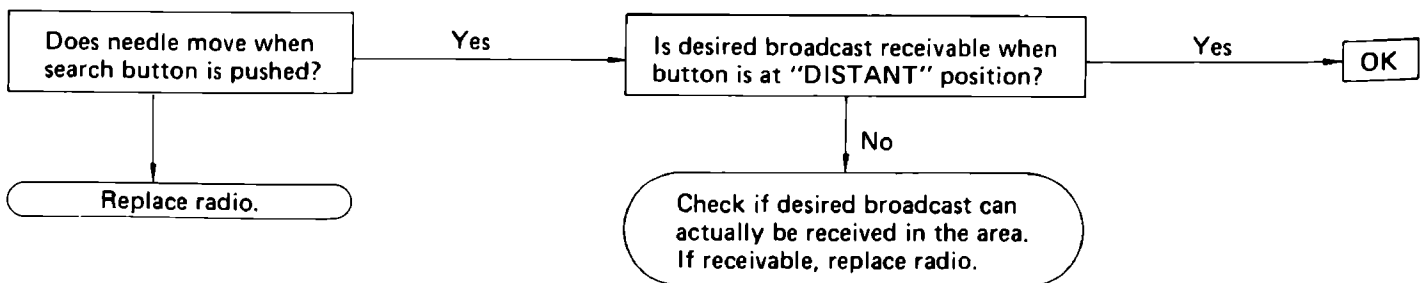

CD Player

Troubleshooting

Check that the operation of other audio systems (Radio, Cassette etc.) are normal.

NOTE: Never attempt to disassemble or oil any part of the player unit. Do not insert any object other than a disc into the slot. Remember there are no user-serviceable parts inside.

CAUTION: Compact Disc players use invisible laser beam which could cause hazardous radiation exposure if directed. Be sure to operate the player correctly as instructed.

Problem	Section
* CD can not be inserted	A
* Does not play	B
Sound jumps	C
Bad sound quality	D
CD will not eject	E

NOTE: For audio systems with anti-theft system, troubleshooting items marked (*) indicate that "Troubleshooting for ANTI-THEFT SYSTEM" should be carried out first.

A CD can not be inserted

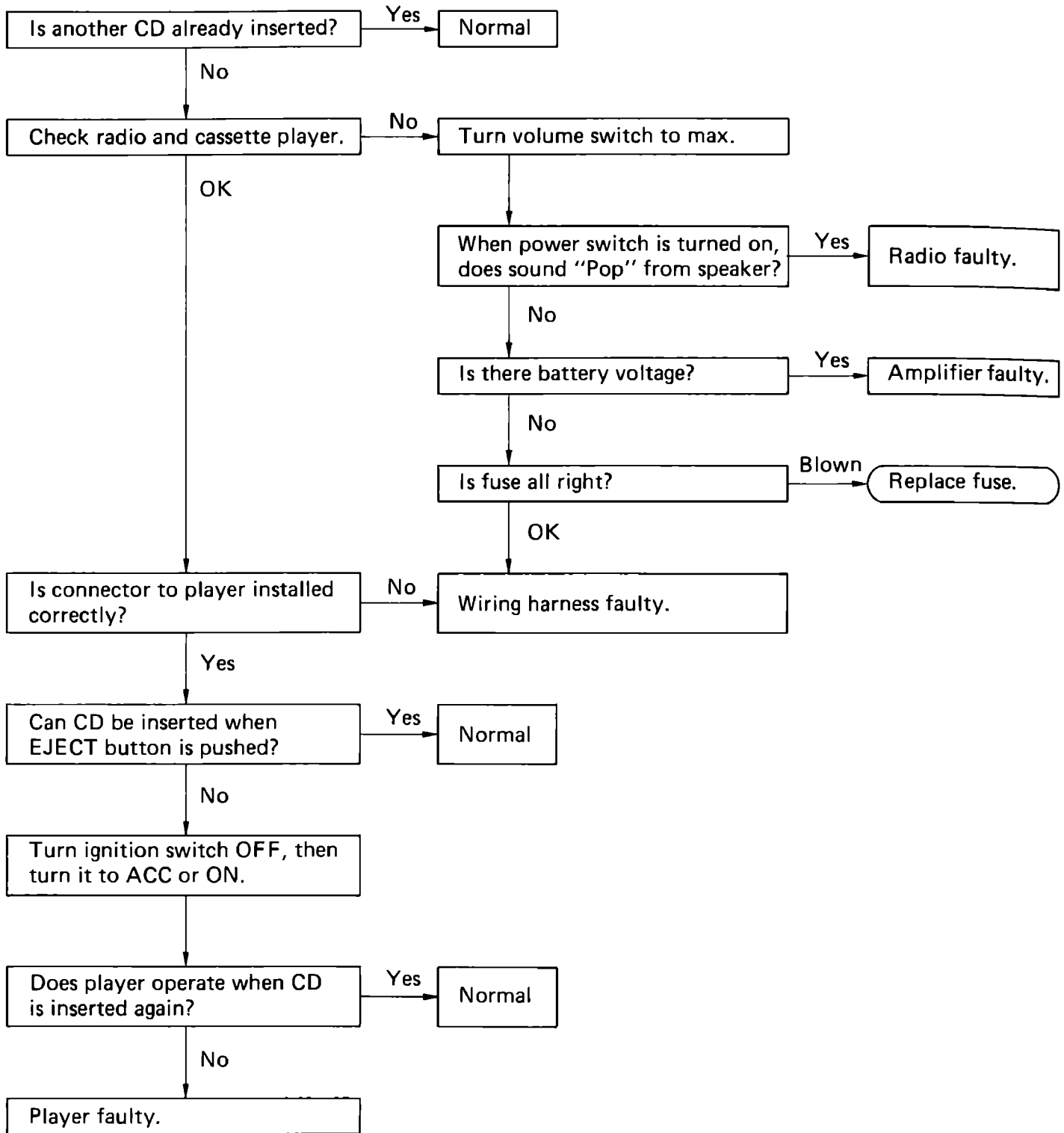

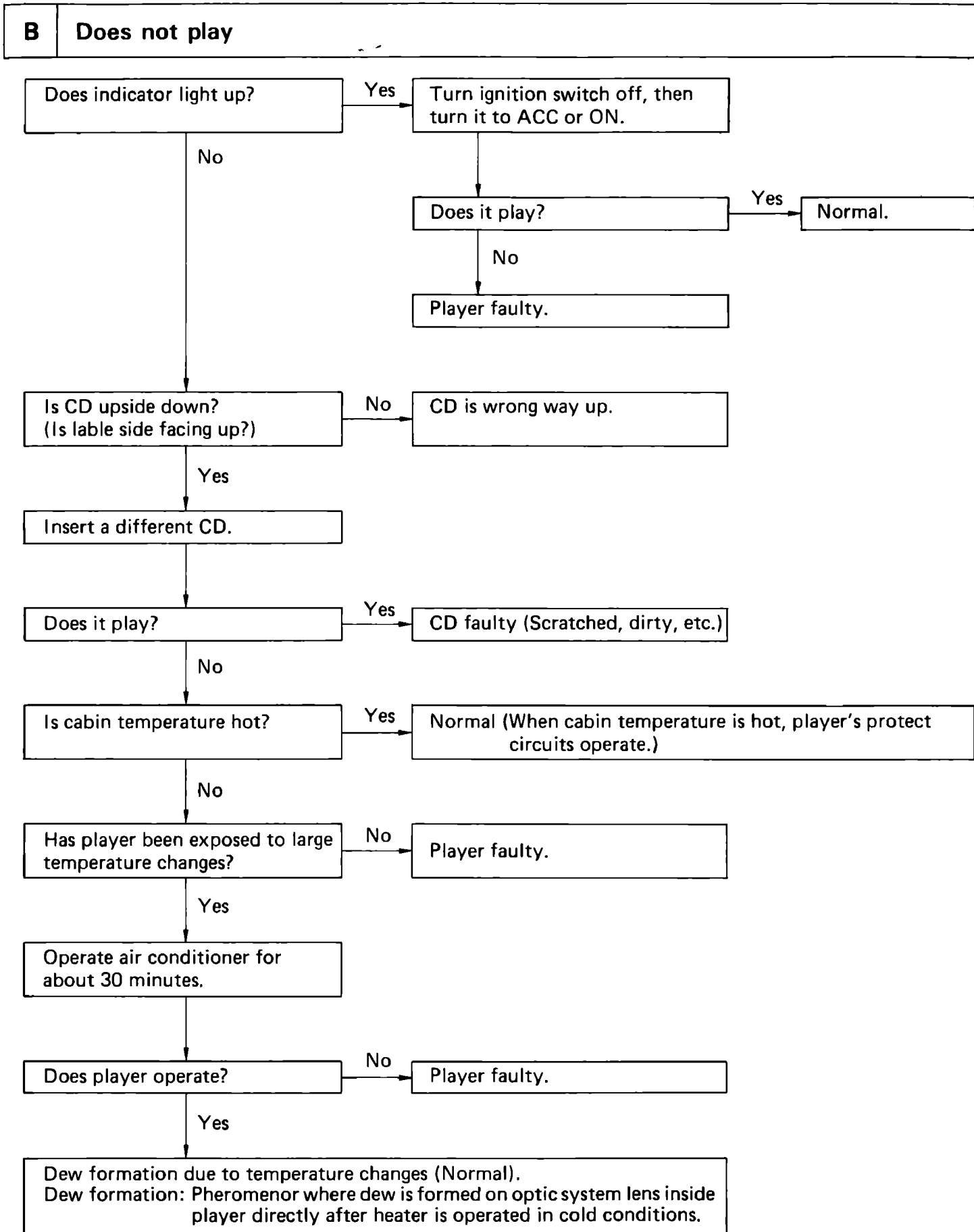

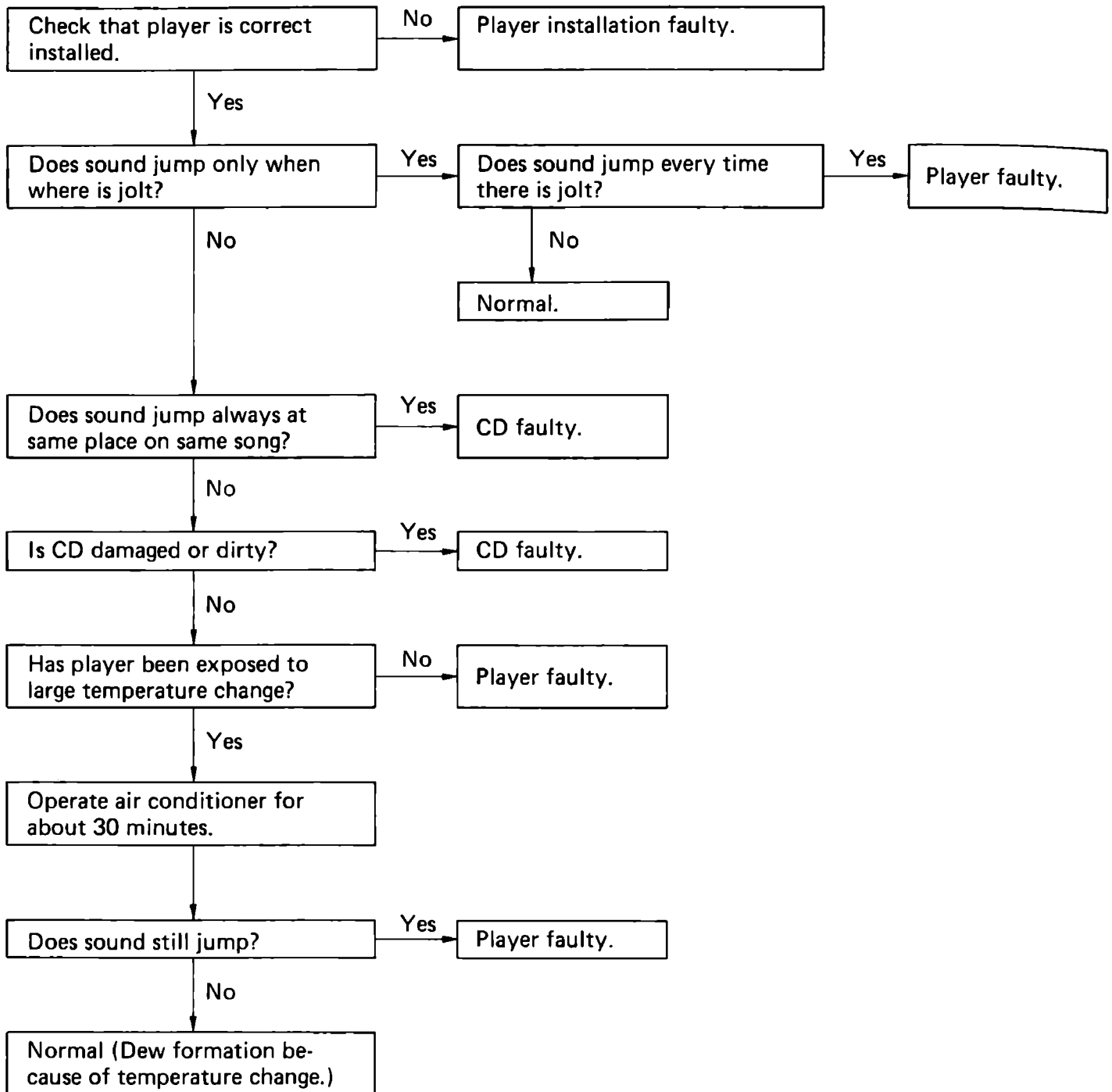
C Sound jumps

D Bad sound quality

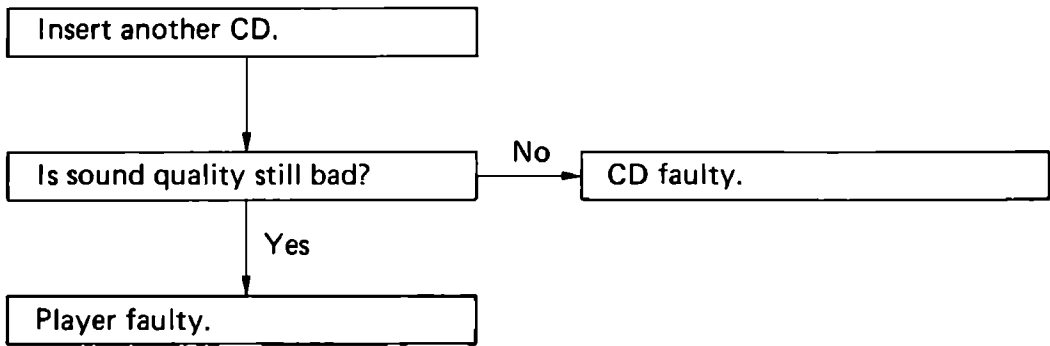

E CD will not eject

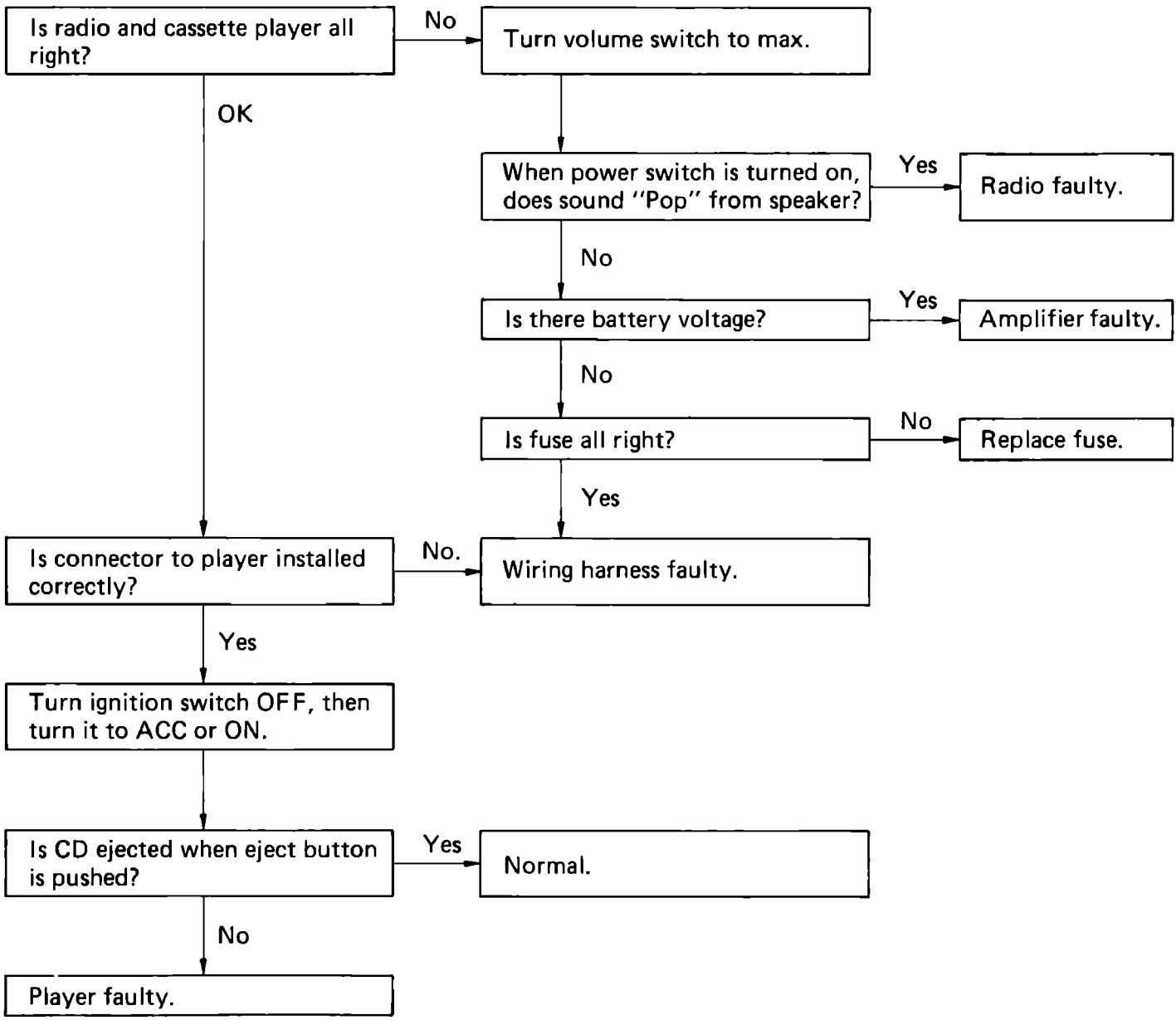

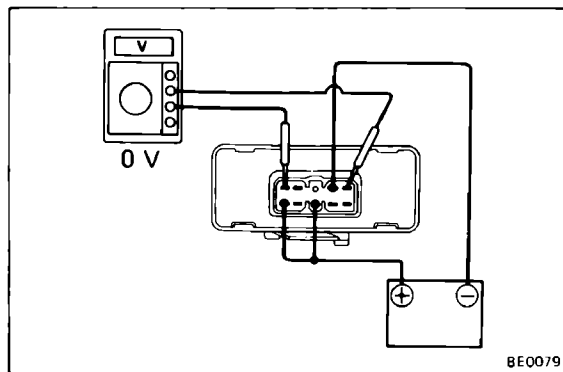
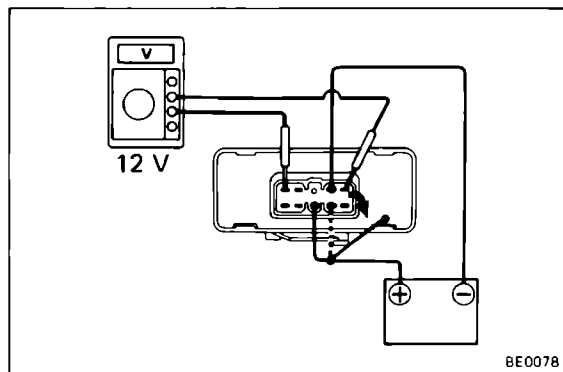
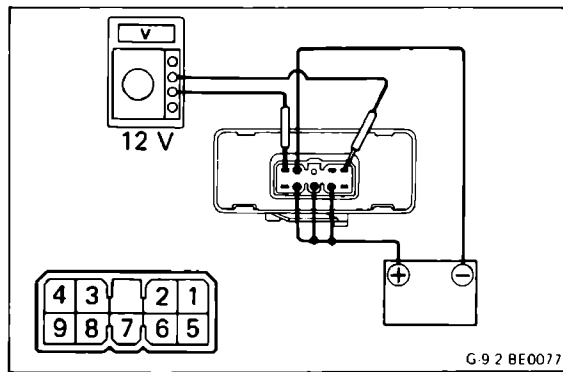

Antenna Motor Control Relay

INSPECTION OF ANTENNA MOTOR CONTROL RELAY

1. INSPECT RELAY OPERATION (ANTENNA UP)
 - (a) Connect the voltmeter positive (+) lead to terminal 1 and the negative (–) lead to terminal 4.
 - (b) Connect the positive (+) lead from the battery to terminals 6, 7 and 8. Connect the negative (–) lead to terminal 3.
 - (c) Check that there is battery voltage.
- NOTE: Measure the voltage within 7 seconds after connecting the positive (+) battery lead to terminal 8.

2. INSPECT RELAY OPERATION (ANTENNA DOWN)
 - (a) Connect the voltmeter positive (+) lead to terminal 4 and the negative (–) lead to terminal 1.
 - (b) Connect the positive (+) lead from the battery to terminals 6 and 7. Connect the negative (–) lead to terminal 2.
 - (c) Disconnect the positive (+) battery lead from terminal 6.
 - (d) Check that there is battery voltage.
- NOTE: Measure the voltage within 7 seconds after disconnecting the positive (+) battery lead from terminal 6.

3. INSPECT RELAY OPERATION (ANTENNA STOP)
 - (a) Connect the voltmeter positive (+) lead to terminal 1 and the negative (–) lead to terminal 4.
 - (b) Connect the positive (+) lead from the battery to terminals 7 and 9. Connect the negative (–) lead to terminal 2.
 - (c) Check that there is no battery voltage.
- If operation is not as specified, replace the relay.

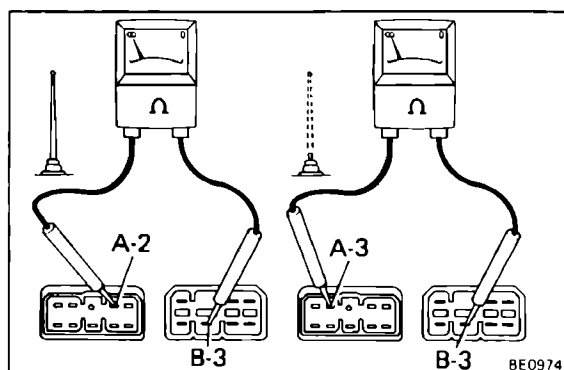

Antenna Motor

INSPECTION OF ANTENNA MOTOR

INSPECT LIMIT SWITCH OPERATION

- (a) If the motor stops with the antenna up, check that there is no continuity between terminals A-2 and B-3.
 - (b) If the motor stops with the antenna down, check that there is no continuity between terminals A-3 and B-3.
- If continuity is not as specified, replace the motor.

CLOCK

Troubleshooting

CLOCK WILL NOT OPERATE

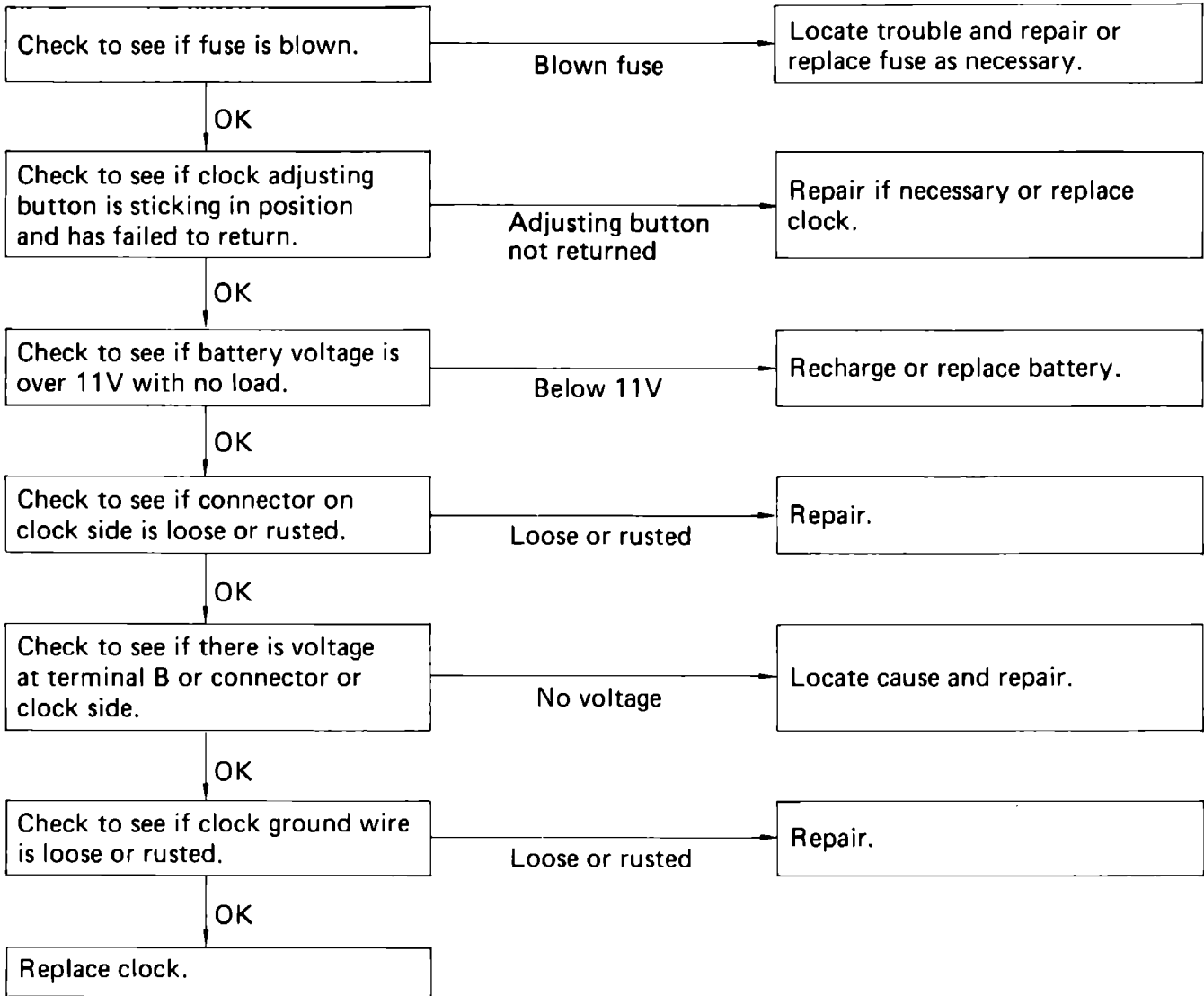

CLOCK LOSES OR GAINS TIME

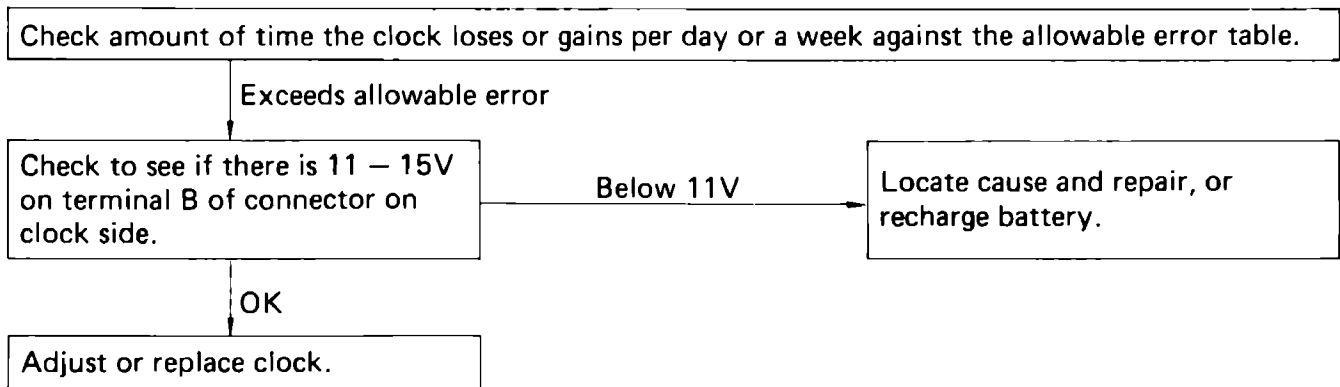

1. INSPECT ALLOWABLE ERROR OF CLOCK

Check the allowable error of the clock.

Allowable error (per day): ± 1.5 seconds

2. ADJUSTMENT OF CLOCK

Adjustment of the quartz clock requires a precise digital counter. Adjustment must be made in a shop specified by the manufacturer.

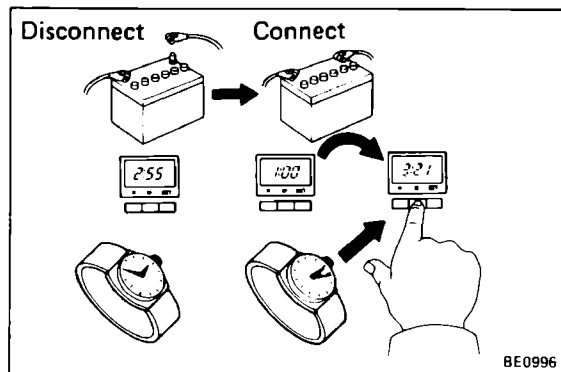
**3. STARTING OF CLOCK**

(a) Connect the battery terminal.

(b) Check the clock to see that it is running, and then set it to the correct time.

NOTE: Whenever the battery terminal is disconnected, make sure to set the clock to the correct time after reconnecting it.