

TOYOTA
ELECTRICAL WIRING DIAGRAM

CELICA

1986 MODEL

FOREWORD

This wiring diagram has been prepared to provide information on the electrical system of the 1986 TOYOTA CELICA ST161, 162 series.

All information in the manual is based on the latest product information at the time of publication. However, specifications and procedures are subject to change without notice.

TOYOTA MOTOR CORPORATION

1986 TOYOTA CELICA ELECTRICAL WIRING DIAGRAM

INTRODUCTION	A	LIGHT AUTO TURN OFF SYSTEM	6
HOW TO USE THIS MANUAL	B	HEADLIGHTS	7
TROUBLESHOOTING	C	INTERIOR LIGHTS	8
GLOSSARY OF TERMS AND SYMBOLS	D	ILLUMINATION	9
POWER SOURCE	1	TAILLIGHTS	10
STARTING AND IGNITION SYSTEM ..	2	BACK-UP LIGHTS	11
CHARGING SYSTEM	3	STOP LIGHTS	12
EFI SYSTEM	4	TURN SIGNAL AND HAZARD WARNING LIGHTS	13
ELECTRICAL IDLE-UP SYSTEM	5	FRONT WIPER AND WASHER	14
		REAR WIPER AND WASHER	15
		REMOTE CONTROL MIRRORS	16
		REAR WINDOW DEFOGGER	17
		DOOR LOCKS	18
		POWER SEAT	19
		POWER WINDOWS	20
		CRUISE CONTROL	21
		ECT AND A/T INDICATOR	22
		AUTO ANTENNA	23
		HORNS	24
		OVERDRIVE	25
		SUN ROOF	26
		CIGARETTE LIGHTER AND CLOCK	27
		UNLOCK AND SEAT BELT WARNING	28
		RADIO AND TAPE PLAYER	29
		COMBINATION METER	30
		RADIATOR FAN AND AIR CONDITIONER	31
		GROUND POINTS	32
		RELAY LOCATIONS	
		ELECTRICAL WIRING ROUTING	
		OVER ALL ELECTRICAL WIRING DIAGRAM	

© 1985 TOYOTA MOTOR CORPORATION

All rights reserved. This book may not be reproduced or copied, in whole or in part, without the written permission of Toyota Motor Corporation.

A INTRODUCTION

This manual is composed of the following 5 elements.

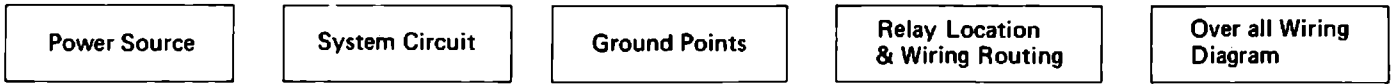

Circuit from battery to each fuse

Each circuit classified by system

Relation between ground points of each component

Relay & Connector location

Shows relation between each system

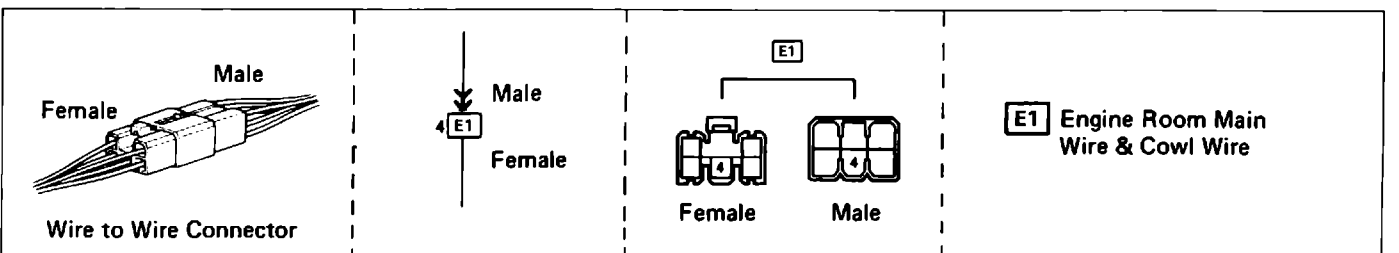
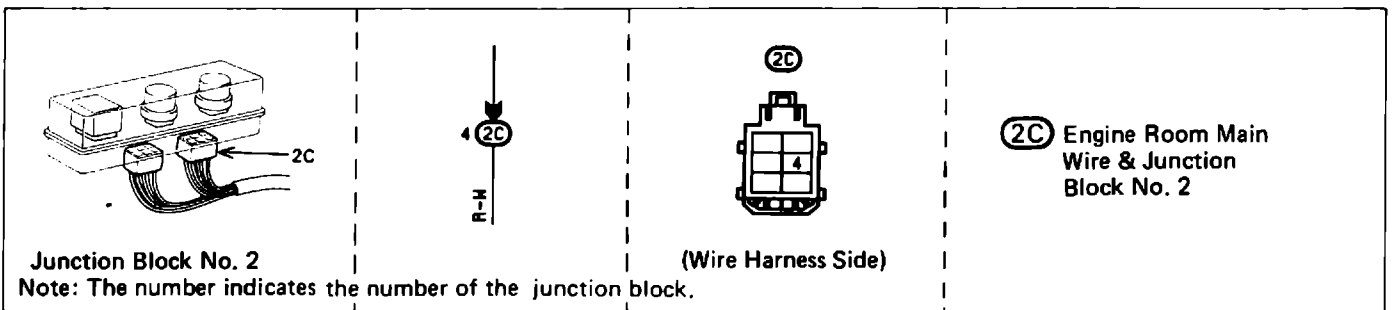
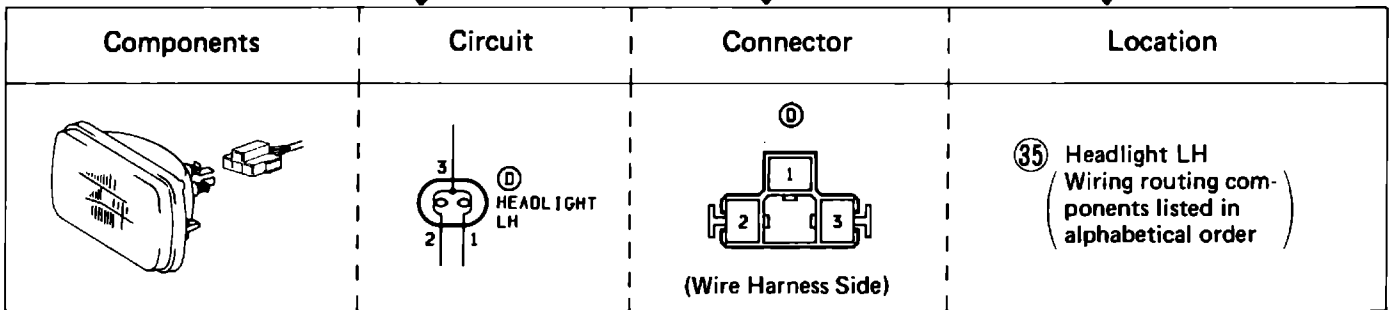
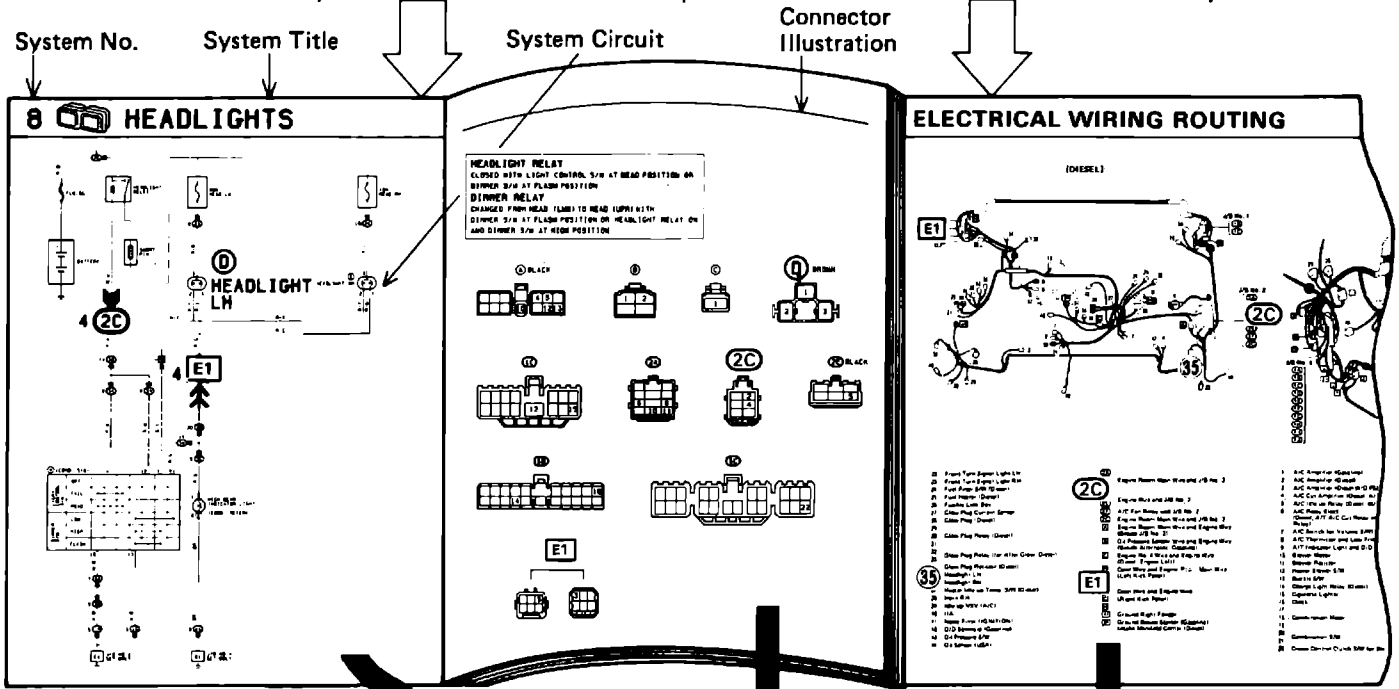

14 REAR WINDOW DEFOGGER

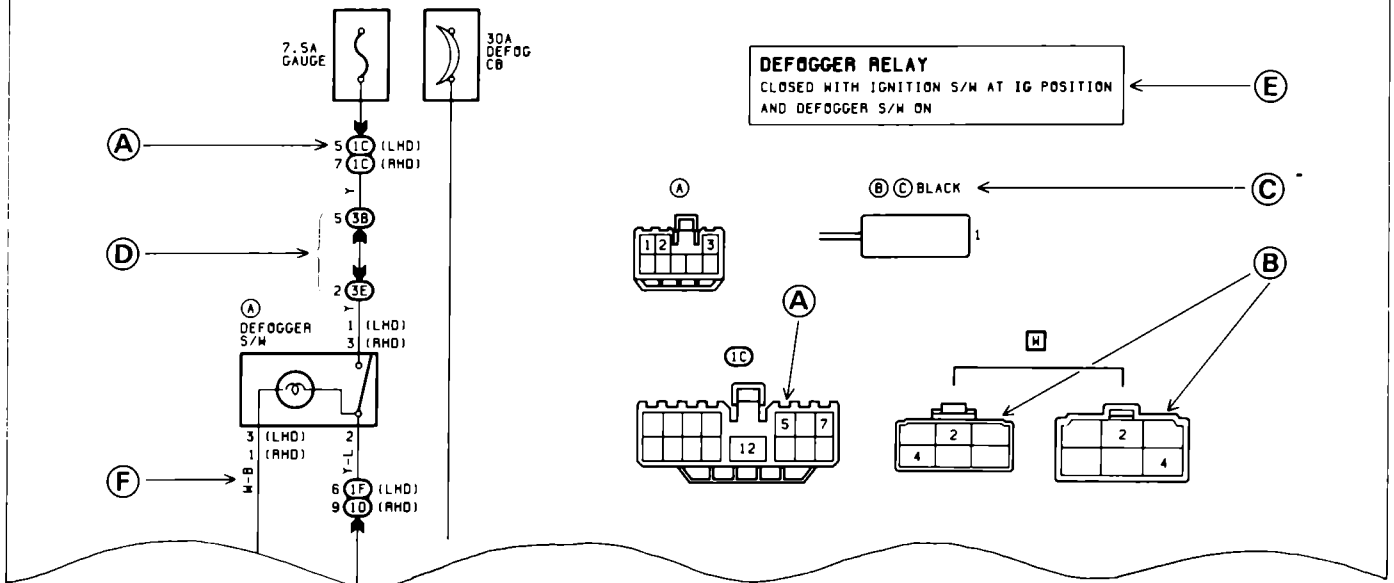

(A) Pin Number

Numbered in order from upper left to lower right

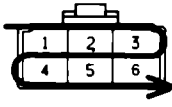

Female

Numbered in order from upper right to lower left

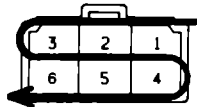

Male

(B) Male & female connectors distinguished by shape of their internal pins.

- All connectors are shown from the open end, and the lock is on top.

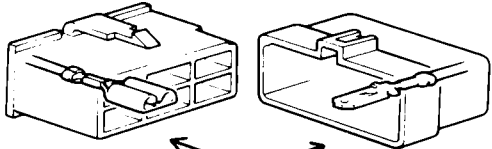

Female

Male

(C) Connector Color

Connectors not indicated are milky white in color.

(D) Indicates circuit in Junction Block No. 3.

Example:

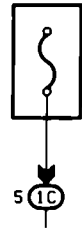

IC indicates that it is inside Junction Block No. 1.

(E) Troubleshooting Hints & Components Operation

(F) Wire Color

Wire colors are indicated by an alphabetical code.

- B = Black L = Light Blue R = Red
- BR = Brown LG = Light Green V = Violet
- G = Green O = Orange W = White
- GR = Gray P = Pink Y = Yellow

The first letter indicates the basic wire color and the second letter indicates the color of the stripe.

Example: R-G

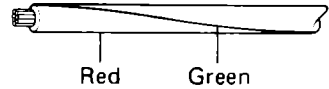

Red Green

ABBREVIATIONS

The following abbreviations are used in this manual.

- | | | |
|---------------------------------|---------------------------|------------------------------|
| A/C = Air Conditioner | FL = Fusible Link | RH = Right-hand |
| A/T = Automatic Transmission | J/B = Junction Block | S/W = Switch |
| CB = Circuit Breaker | LH = Left-hand | VSV = Vacuum Switching Valve |
| C/P = Coupe Type | M/T = Manual Transmission | W/ = With |
| EFI = Electrical Fuel Injection | O/D = Overdrive | W/O = Without |

B HOW TO USE THIS MANUAL

To better understand how to use this manual, let's assume that the headlights will not light, and go through an actual troubleshooting procedure.

CONFIRMATION OF TROUBLE

Turn on the headlight switch and check for yourself that the headlights do not come on.

READ THE CIRCUIT DIAGRAM

1. Locate the headlight system number in the index and open the manual to the page indicated. (The system number is written in bold at the top corner of each page).
2. Read the circuit diagram to learn how it works.
3. Unfold the ELECTRICAL WIRING ROUTING page at the back of the manual.

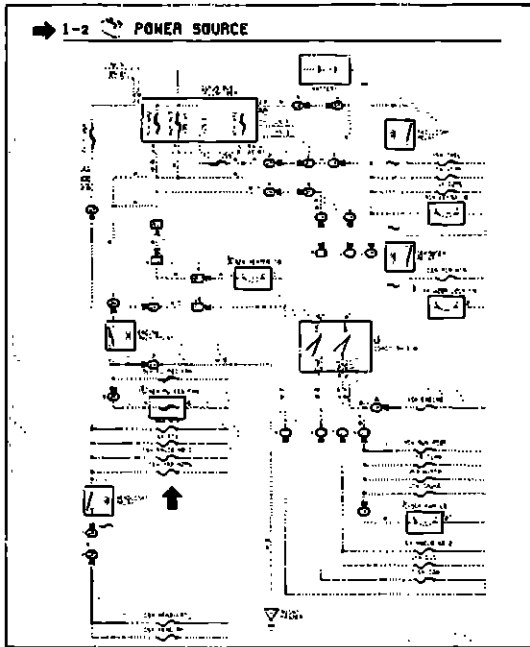

PINPOINT THE TROUBLE

If the circuit is in common with others (power circuit or ground point), problems will occur in some of the others also. Please refer to POWER SOURCE (System No. 1-2). Since the headlights are related to the HAZ-HORN, check this circuit.

Okay	Trouble lies within the headlight circuit.
Bad	Check circuits in common.

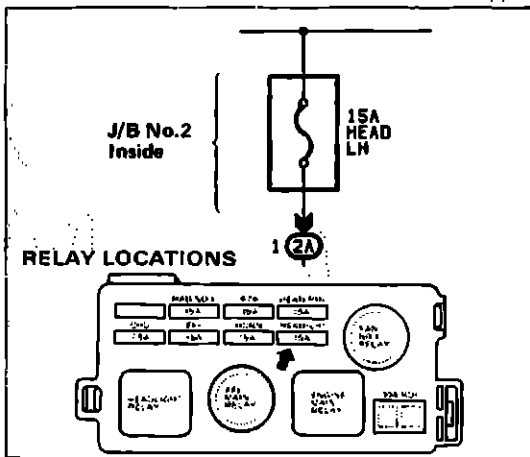

1. Inspection of Headlight Circuit
(Return to HEADLIGHT page.)

(a) Check Headlight Fuse

- ① According to 2A of the circuit, the headlight fuse is in J/B No. 2.
- ② The location of J/B No. 3 can be found by referring to the RELAY LOCATIONS page just before the ELECTRICAL WIRING ROUTING page.
- ③ Check if either fuse is blown.

(b) Check if there is power to pin No. 1 of 2A .

- ① Turn the light control switch to HEAD.
- ② Using a voltmeter, check for voltage as shown below.

{	Negative (-) Probe	Good ground point or negative battery terminal.
	Positive (+) Probe	Pin No. 1 of 2A

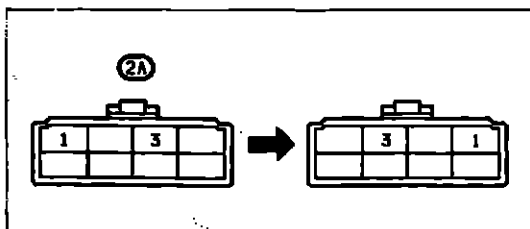

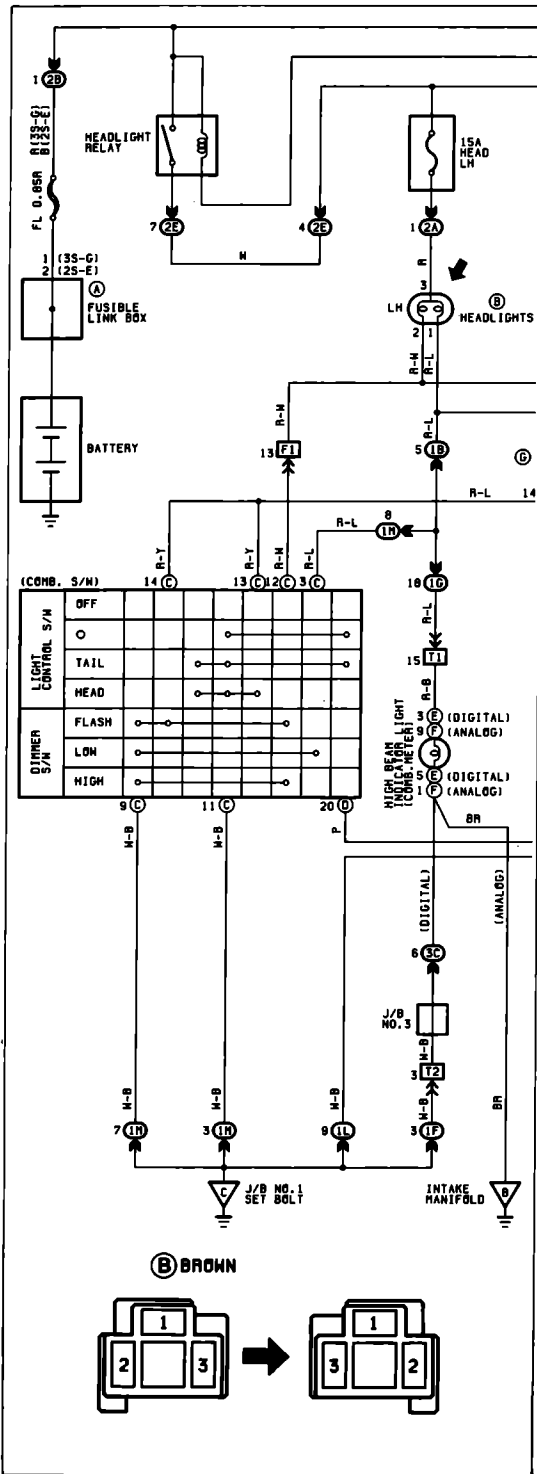

Battery Voltage Trouble is past pin No. 1 of 2A .
 No Battery Voltage Trouble is before pin No. 1 of 2A .

CAUTION:

Insert the tester probes from the wire harness side of the connector. Consequently, note that the pin numbers will be in reverse order of that shown in the illustration.

(c) Check if there is power to the headlights.

- ① From the circuit we can see that ② is the headlight connector and that there is power from pin No. 3 to 2 when the headlights are at high beam.
- ② Turn the light control switch to HEAD.
- ③ Place the dimmer switch at HI.
- ④ Using a voltmeter, check for voltage as shown below.

{ Negative (-) probe . . . Pin No. 2 of connector ② .
 { Positive (+) probe . . . Pin No. 3 of connector ② .

Voltage Trouble is in the headlight.
 No Voltage Probable defective ground past pin No.2 so make contact with negative lead to a good ground point or battery negative terminal and check for voltage.

Voltage Trouble is past pin No. 2 of ② .
 No Voltage Trouble is before pin No. 3 of ② .

CAUTION:

Do not check for continuity while voltage is applied or it may result in damage to the tester.

(d) To check the low beam, place the dimmer switch at LOW and perform the check in the same sequence.

(e) Check ground point

- 1 The ground point is indicated by the ▽ J/B No. 1 SET BOLT in the circuit.
- 2 The location of the ground point on the vehicle can be found by referring to the same symbol ▽ in ELECTRICAL WIRING ROUTING.

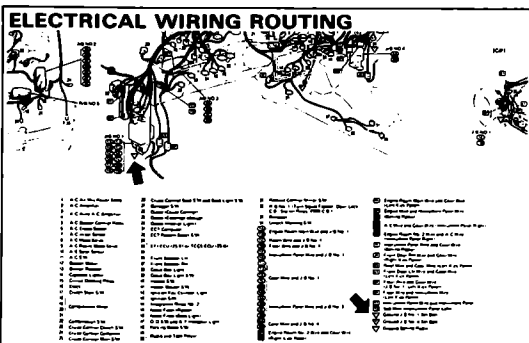

B HOW TO USE THIS MANUAL

➔ 1-1 POWER SOURCE (Power-Load Reference)

J/B No.2 (Engine Compartment)		
30A	RFR	Retract Control Relay
7.5A	CHARGE	Alternator
➔ 15A	HEAD LH	Headlight (LH)
15A	HEAD RH	Headlight (RH)
15A	HAZ HORN	Turn Signal Flasher Horn, Horn Relay
15A	EFI	Circuit Opening Relay, TCCS ECU, Check Connect
		Radio and Tape Player
		ECT Computer
15A	RADIO NO. 1	Auto Antenna
		Clock
		Combination Meter (Optional)

2. Inspection of Common Circuits

(a) Check battery and fusible link

(b) Check related systems

Check how the HEAD FUSE is related to the system. In system No. 1-1 (POWER SOURCE), you will find a chart listing the relationship between the fuses and components. Here we can see that the HEAD fuses are related only to their respective headlights.

(c) Check the circuit from the battery to the HEAD FUSE.

① In system No. 1-2 (POWER SOURCE), the power circuits for all fuses are listed. The circuit between the battery and HEAD fuse branches off with fuses HAZ-HORN 15A etc.

② Turn on the HAZARD switch

Okay No trouble in circuit up to HAZ-HORN junction.

Bad Trouble lies between fusible link and J/B No. 2.

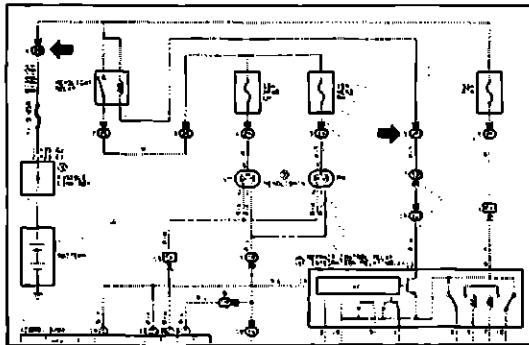
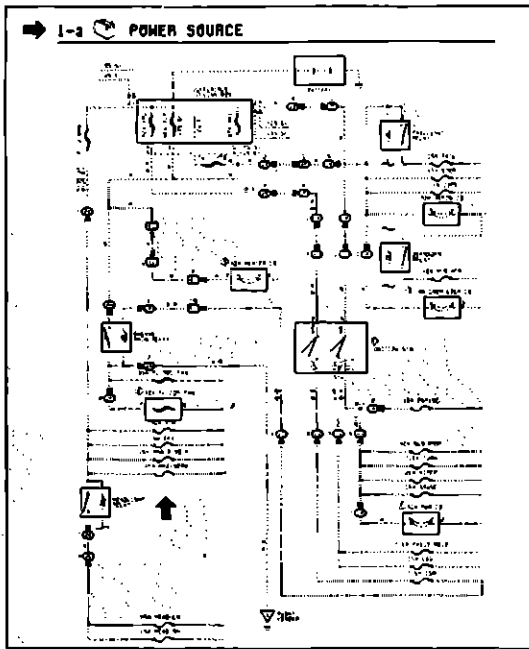

(d) Check the HEADLIGHT RELAY
(Return to HEADLIGHT page)

1 The circuit shows that the HEADLIGHT RELAY is in J/B No. 2.

2 Installation of the relay can be found by referring to the RELAY LOCATIONS. The HEADLIGHT RELAY is located in J/B No. 2 in the engine compartment as shown.

3 Check for power to the headlight relay coil.

① Turn the headlight switch to HEAD.

② Using a voltmeter, check for voltage as shown below.

{ Negative (-) Probe Pin No. 5 of . . .
Positive (+) Probe Pin No. 1 of . . .

Confirm that there is voltage

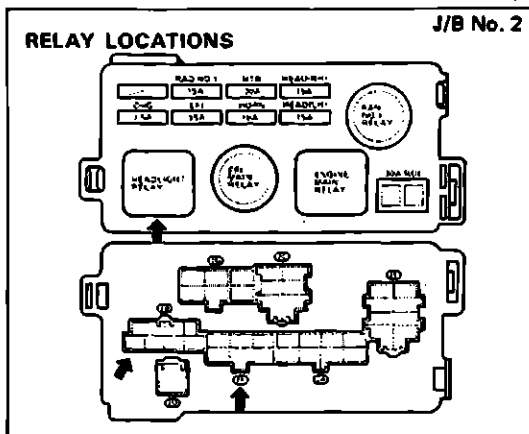

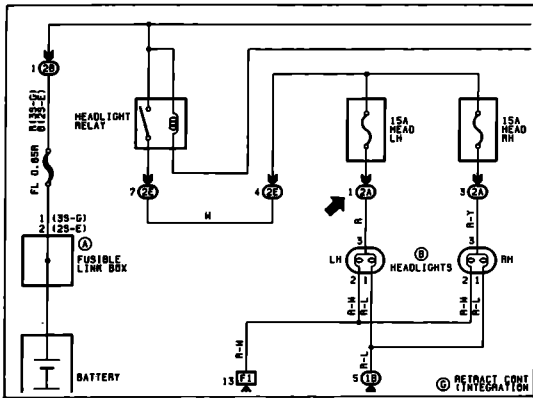

- 4 Next, check if the headlight relay points are closed and there is power to the pin No. 1 of 2A. See step 1-(b)

If no voltage, trouble lies in the headlight relay.

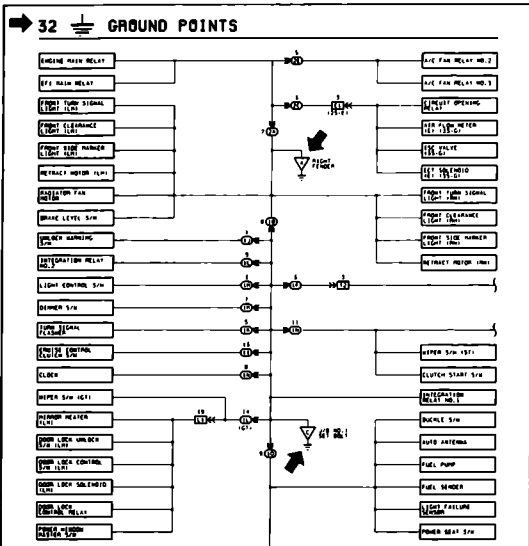

- (e) Check which systems (components) have the same ground point. The ground points are listed in system No. 32 (GROUND POINTS). As shown, GROUND POINT ∇ is used for other components besides the HEADLIGHT SYSTEM, and it also connected to GROUND POINT ∇ .

CELICA SYSTEM INDEX			
CELICA		1988 Model (Page 1 to Page 7)	
SYSTEMS	LOCATION	SYSTEMS	LOCATION
Air Conditioner, Cooler and Heater	2-5, 3-5	Power Seats	6-7
Auto Antenna	7-4	Power Source	1-1
EFI	1-5	Taillights and Illumination	5-4
Front Wiper and Washer	2-7	Turn Signal and Hazard	8-4
Headlights	5-7	Unlock and Safe Bolt Warning	6-1
Horn	8-5	Idle-up	1-8
Ignition	2-1		

- (f) Check how the HEADLIGHT SYSTEM is connected to the other systems. 1 From the EWD SYSTEM INDEX (facing the first EWD), we can find the location of the headlight system within the ELECTRICAL WIRING DIAGRAM at the back of the book (Page 5 of 7, grid 8).

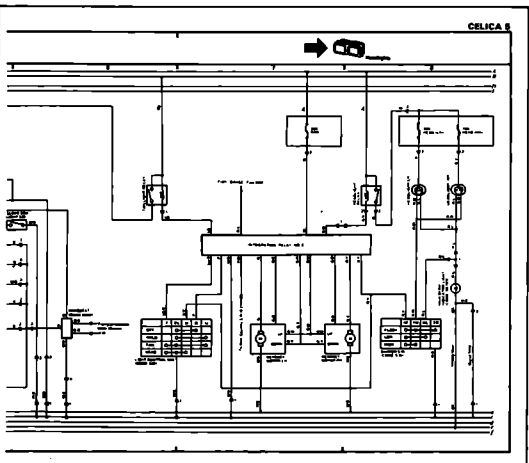

- 2 By referring to the ELECTRICAL WIRING DIAGRAM, we can see that the HEADLIGHT SYSTEM is related to the TAIL and ILLUMINATION SYSTEM.

- NOTE: The relationship between system circuits is not shown so always confirm with the overall wiring diagram.
- (g) Re-check After repair, check that the circuit functions normally. Always follow the steps described above to narrow down the possible range of the trouble.

C TROUBLESHOOTING

TROUBLESHOOTING PROCEDURE

1. Determine what is wrong with the system.
2. First read the diagram so you understand the system. Refer to the component operation boxed within the system circuit.
3. Locate the cause of the problem.
 - a. Determine whether the problem is with the common circuit (power source or ground) or individual circuit.

Check other loads or switches which are in parallel with the problem component.

If they are normal, the problem lies within the particular system itself.

Refer to the POWER SOURCE or GROUND POINTS and check the related systems.

(NOTE: Each component is grounded at 2 or 3 points.)

If the related systems are normal, the common circuit (power source or ground points) is okay.

The problem lies within the individual system.
 - b. Locate the exact point of the problem by narrowing down the area with a voltmeter or test-lamp.
4. Repair and re-check the circuit.

If any wiring was disconnected for troubleshooting, reconnect it and check the related circuits.

VOLTAGE CHECK

1. Establish conditions in which voltage is present at the check point.

(Refer to component operations.)

Example:

- A - Ignition S/W on
- B - Ignition S/W and S/W 1 on
- C - Ignition S/W, S/W 1 and Relay on
(S/W 2 off)

2. Using a voltmeter, connect the negative lead to a good ground point or negative battery terminal and the positive lead to the connector or component terminal. This check can be done with a test lamp instead of a voltmeter.

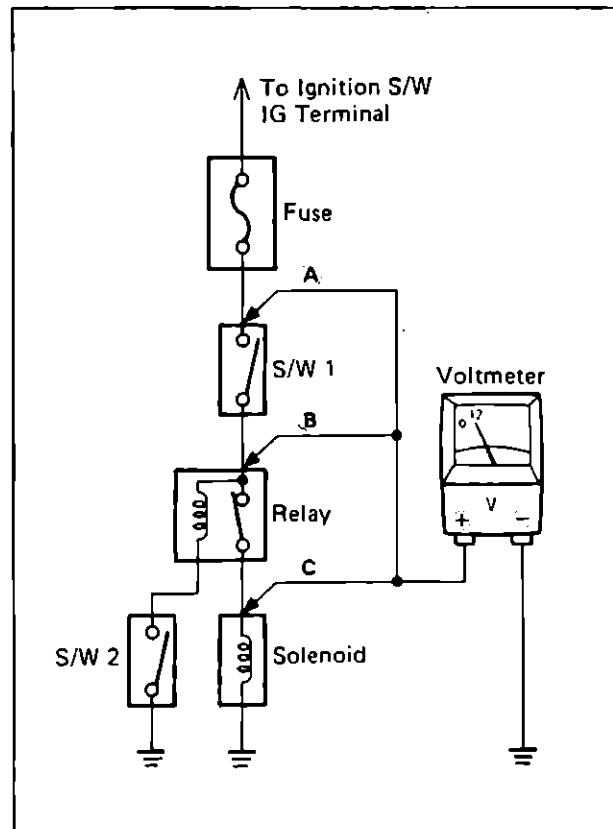

CONTINUITY AND RESISTANCE CHECK

1. Disconnect the battery terminal or wire so there is no voltage between the check points.
2. Contact the two leads of an ohmmeter to each of the check points.

If the circuit has diodes, reverse the two leads and check again.

When contacting the negative lead to the diode positive side and the positive lead to the negative side, there should be continuity.

When contacting the two leads in reverse, there should be no continuity.

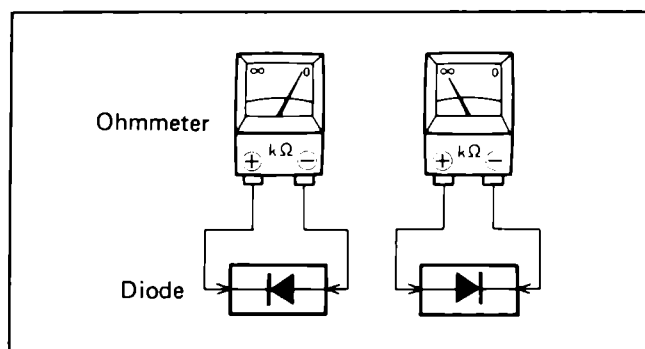
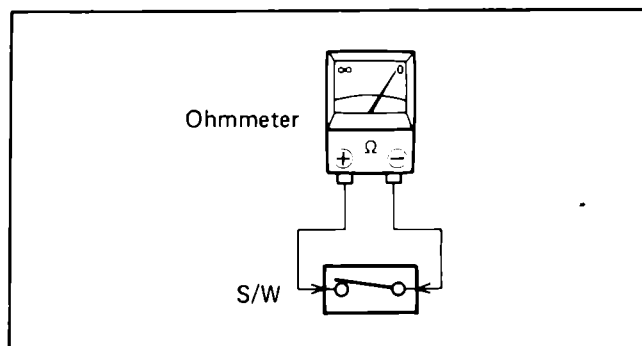

FINDING A SHORT CIRCUIT

1. Remove the blown fuse and disconnect all loads of the fuse.
2. Connect a test lamp in place of the fuse.
3. Establish conditions in which the test lamp comes on.

(Refer to component operations.)

Example:

- Ⓐ — Ignition S/W on
- Ⓑ — Ignition S/W and S/W 1 on
- Ⓒ — Ignition S/W, S/W 1 and Relay on
(Connect the Relay) and S/W 2 off
(or Disconnect S/W 2)







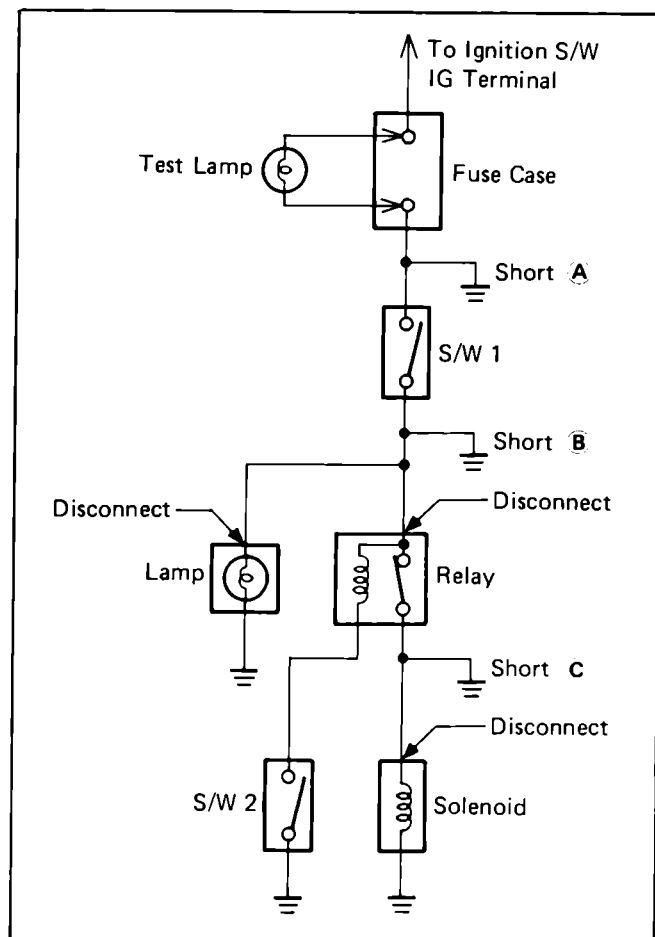



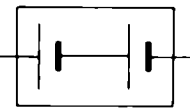

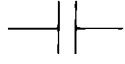

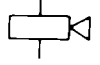
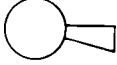
4. Disconnect and reconnect the connectors while watching the test lamp.

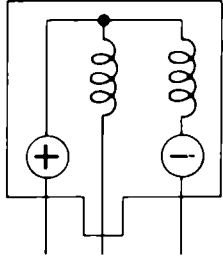

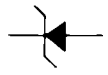
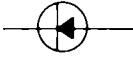
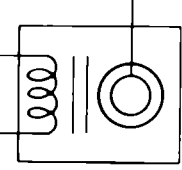



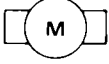



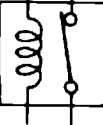
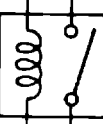

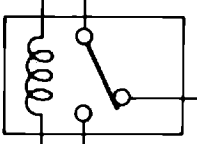
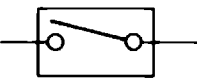
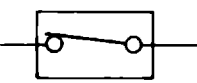
The short lies between the connector where the test lamp stays lit and the connector where the lamp goes out.

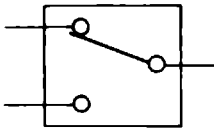
5. Find the exact location of the short by lightly shaking the problem wire along the body.

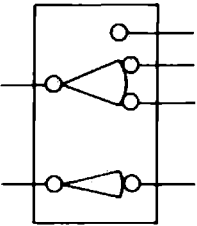

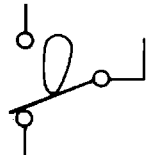
D GLOSSARY OF TERMS AND SYMBOLS

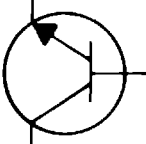
 <p>BATTERY Stores chemical energy and converts it into electrical energy. Provides DC current for the auto's various electrical circuits.</p>	 <p>HEADLIGHTS Current flow causes a headlight filament to heat up and emit light. A headlight may have either a single (1) filament or a double (2) filament.</p> <p>1. SINGLE FILAMENT</p>
 <p>CAPACITOR (Condenser) A small holding unit for temporary storage of electrical voltage. Capacitors with a ground connection are frequently called Condensers.</p>	<p>2. DOUBLE FILAMENT</p> 
 <p>CIGARETTE LIGHTER An electric resistance heating element.</p>	<p>HORN An electric device which sounds a loud audible signal.</p> 
 <p>CIRCUIT BREAKER Basically a reusable fuse, a circuit breaker will heat and open if too much current flows through it. Some units automatically reset when cool, others must be manually reset.</p>	<p>IGNITION COIL Converts low-voltage DC current into high-voltage ignition current for firing the spark plugs.</p> 
 <p>DIODE A semiconductor which allows current flow in only one direction.</p>	<p>LIGHT Current flow through a filament causes the filament to heat up and emit light.</p> 
<p>DIODE, ZENER</p>  <p>A diode which allows current flow in one direction but blocks reverse flow only up to a specific voltage. Above that potential, it passes the excess voltage. This acts as a simple voltage regulator.</p>	<p>LED (LIGHT EMITTING DIODE) Upon current flow, these diodes emit light without producing the heat of a comparable light. Used in instrument displays.</p> 
 <p>DISTRIBUTOR, IIA Channels high-voltage current from the ignition coil to the individual spark plugs.</p>	<p>METER, ANALOG Current flow activates a magnetic coil which causes a needle to move, thereby providing a relative display against a background calibration.</p> 
 <p>FUSE A thin metal strip which burns through when too much current flows through it, thereby stopping current flow and protecting a circuit from damage.</p>	<p>METER, DIGITAL Current flow activates one or many LED's, LCD's, or fluorescent displays, which provide a relative or digital display.</p> 
 <p>FUSIBLE LINK A heavy-gauge wire placed in high amperage circuits which burns through on overloads, thereby protecting the circuit.</p>	<p>MOTOR A power unit which converts electrical energy into mechanical energy, especially rotary motion.</p> 
 <p>GROUND The point at which wiring attaches to the chassis, thereby providing a return path for an electrical circuit; without a ground, current cannot flow.</p>	

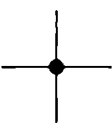
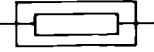
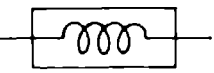
<p>RELAY</p>  <p>1. NORMALLY CLOSED</p>  <p>2. NORMALLY OPEN</p> <p>Basically, an electrically operated switch which may be normally closed (1) or open (2). Current flow through a small coil creates a magnetic field which either opens or closes an attached switch.</p>	 <p>SPEAKER</p> <p>An electromechanical device which creates sound waves from current flow.</p>
 <p>RELAY, DOUBLE THROW</p> <p>A relay which passes current through one set of contacts or the other.</p>	<p>SWITCH, MANUAL Opens and closes circuits, thereby stopping (1) or allowing (2) current flow.</p> <p>1. NORMALLY OPEN</p>  <p>2. NORMALLY CLOSED</p> 
 <p>RESISTOR</p> <p>An electrical component with a fixed resistance, placed in a circuit to reduce voltage to a specific value.</p>	<p>SWITCH, DOUBLE THROW</p> <p>A switch which continuously passes current through one set of contacts or the other.</p> 
 <p>RESISTOR, TAPPED</p> <p>A resistor which supplies two or more different non-adjustable resistance values.</p>	<p>SWITCH, IGNITION</p> <p>A key operated switch with several positions which allow various circuits, Particularly the primary ignition circuit, to become operational.</p> 
 <p>RESISTOR, VARIABLE or RHEOSTAT</p> <p>A controllable resistor with a variable rate of resistance. Also called a potentiometer or rheostat.</p>	<p>SWITCH, WIPER PARK</p> <p>Automatically returns wipers to the stop position when the wiper switch is turned off.</p> 
 <p>SENSOR (Thermistor)</p> <p>A resistor which varies its resistance with temperature.</p>	<p>TRANSISTOR</p> <p>A solidstate device typically used as an electronic relay; stops or passes current depending on the applied voltage at "base"</p> 
 <p>SENSOR, ANALOG SPEED</p> <p>Uses magnetic impulses to open and close a switch to create a signal for activation of other components.</p>	<p>WIRES</p> <p>1. NOT CONNECTED</p>  <p>2. SPLICED</p>  <p>Wires are always drawn as straight lines on wiring diagrams. Crossed wires (1) without a black dot at the junction are not joined; crossed wires (2) with a black dot at the junction are spliced (joined) connections.</p>
 <p>SHORT PIN</p> <p>Used to provide an unbroken connection within a junction block.</p>	
 <p>SOLENOID</p> <p>An electromagnetic coil which creates a magnetic field upon current flow, to move a plunger, etc.</p>	



J/B No.1 (Left kick Panel)

Power		Load	System No.
7.5A	IGN	Engine Main Relay	1
		Charge Warning Light	3
		EFI Main Relay	4
		Radiator Fan Relay No. 1, A/C Fan Relay No. 3	31
20A	WIPER	Washer Motor, Wiper Motor, Wiper Relay	14
		Rear Washer Motor, Rear Wiper Relay, Rear Wiper Motor	15
15A	STOP	TCCS ECU	4
		Stop Lights, Hi Mount Stop Light, Light Failure Sensor	12
		Cruise Control Computer	21
		ECT ECU	22
7.5A	TURN	Turn Signal Flasher	13
15A	GAUGE	Check Engine Warning Light	4
		Integration Relay No. 2	6
		Back-up Lights	11
		Defogger S/W, Defogger Relay, Defogger Indicator Light	17
		A/T Indicator, Pattern Select S/W	22
		O/D Off Indicator Light, O/D Solenoid	25
		Seat Belt Warning Light, Integration Relay No. 1	28
		Heater Relay, Magnet Clutch Relay	31
		Light Failure Sensor, Rear Lights Warning	10
Combination Meter	30		
15A	TAIL	ISC Valve	5
		Glove Box, Light, Combination Meter Light, Radio Pattern Select S/W, Cruise Control Main S/W, Hazard S/W, O/D Main S/W, Defogger S/W Cigarette Lighter, Heater Blower S/W	9
		Clearance Lights, Front Side Marker Lights, Licence Plate Lights, Rear Side Marker Lights Light Failure Sensor, Taillight	10
		Clock	27
30A	SUN ROOF	Cruise Control Main S/W	21
		ECT ECU	22
		Auto Antenna	23
7.5A	RADIO NO. 2	Remote Control Mirror S/W, Mirror Motor	16
		Radio and Tape Player	29
7.5A	DOME	Personal Light, Ignition Key Cylinder Light, Interior Light Door Warning Light, Luggage Compartment Light	8
		Integration Relay No. 1	28
10A	MIR. HTR	ISC Valve	5
		Mirror Heater	17

J/B No.1 (Left kick Panel)

Power		Load	System No.
10A	ENGINE	Alternator	3
15A	CIG	Cigarette Lighter, Clock	25
		Auto Antenna	23
30A	DEFOG CB	Rear Window Defogger	17

J/B No.2 (Engine Compartment)

30A	RTR	Retract Control Relay	7
7.5A	CHARGE	Alternator	3
15A	HEAD LH	Headlight (LH)	7
15A	HEAD RH	Headlight (RH)	7
15A	HAZ-HORN	Turn Signal Flasher	13
		Horns, Horn Relay	24
15A	EFI	Circuit Opening Relay, TCCS ECU, Check Connector	4
15A	RADIO NO. 1	Radio and Tape Player	29
		ECT Computer	22
		Auto Antenna	23
		Clock	27
		Combination Meter (Digital)	30
30A	FL RDI, FAN	Radiator Fan Motor	31

J/B No.4 (Right kick Panel)

10A	A/C	A/C S/W, A/C Amplifier	31
30A	HEATER CB	Blower Motor	31

Fusible Link Box (Near the Battery)

30A	FL AM ₂	Ignition S/W (AM ₂)	1
30A	FL CDS FAN	Condenser Fan Motor	31
40A	FL AM ₁	Ignition S/W (AM ₁)	1
		Alternator	3
80A	ALT (3S-G)	Alternator	3

Fusible Links (Near the Battery)

FL 0.85R	Headlight Relay	1
FL 1.25B (2S-E)	Taillight Relay	1
	Alternator	3

Circuit Breaker (Near the J/B No.1)

30A	PWR CB	Power Window Master S/W	20
		Sun Roof Control Computer	26
		Power Seat S/W, Support Motor	19
14A	DOOR LOCK	Door Lock Control Relay	18

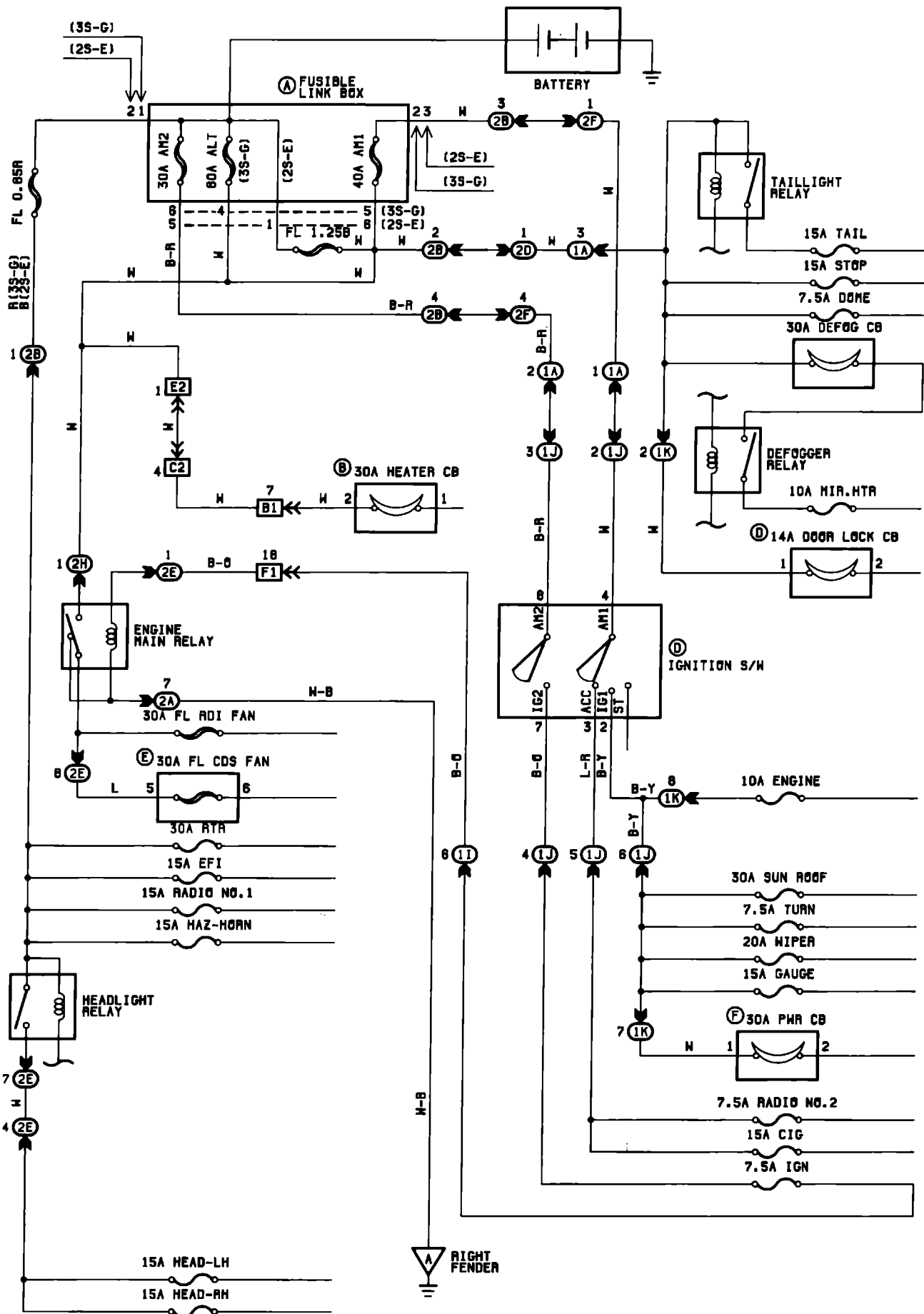

TAILLIGHT RELAY
 CLOSED WITH LIGHT CONTROL S/W AT TAIL OR HEAD POSITION

ENGINE MAIN RELAY
 CHANGED WITH IGNITION S/W AT IG OR ST POSITION

HEADLIGHT RELAY
 4-5: CLOSED WITH LIGHT CONTROL S/W AT HEAD POSITION
 OR DIMMER S/W AT FLASH POSITION

① IGNITION S/W
 4-3 : CLOSED WITH IGNITION KEY AT ACC OR IG POSITION
 8-7-4-2: CLOSED WITH IGNITION KEY AT IG OR ST POSITION

DEFOGGER RELAY
 CLOSED WITH IGNITION S/W AT IG OR ST POSITION

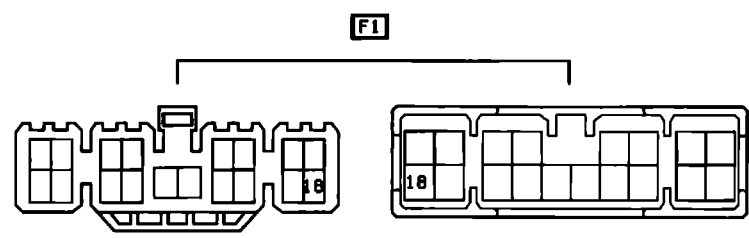
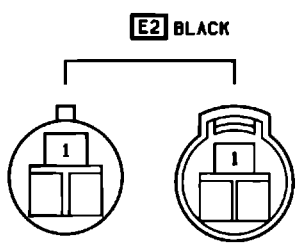
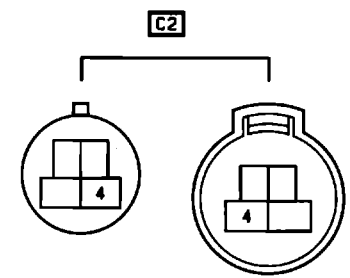
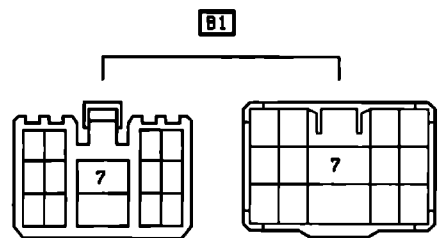
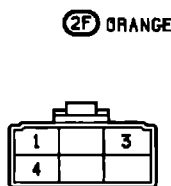
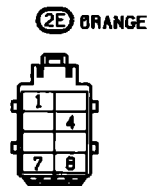
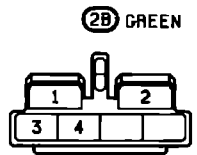
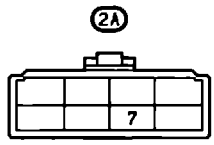
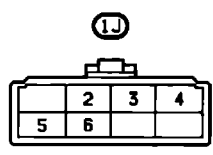
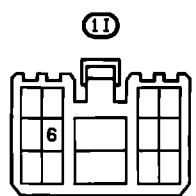
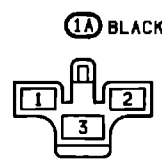
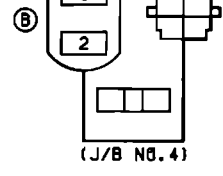
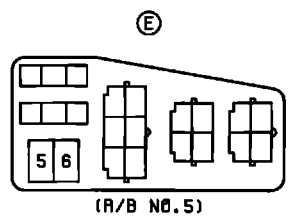
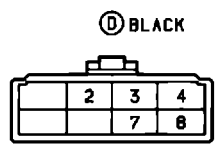
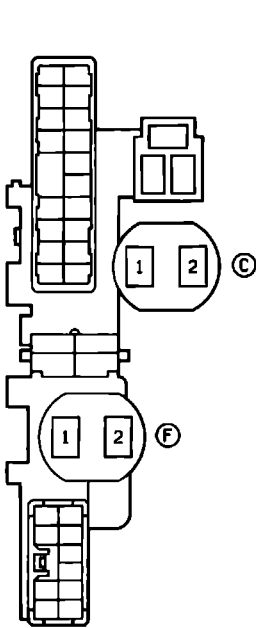
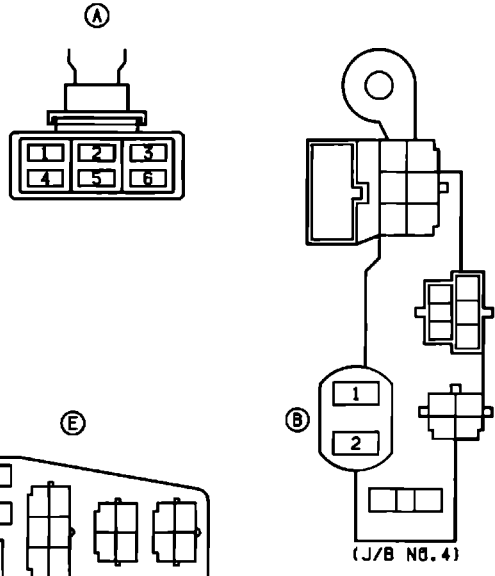

2 STARTING AND IGNITION SYSTEMS

(A) IGNITION S/W
 4-1: CLOSED WITH IGNITION S/W AT ST POSITION
 8-7: CLOSED WITH IGNITION S/W AT IG OR ST POSITION

(C) STARTER RELAY
 2-4: CLOSED WITH CLUTCH START S/W ON AND IGNITION S/W AT ST POSITION

(D) CLUTCH START S/W
 2-1: CLOSED WITH CLUTCH PEDAL FULLY DEPRESSED

STARTER
 POINTS CLOSED WITH CLUTCH START S/W ON AND IGNITION S/W AT ST POSITION

(E) (F) NEUTRAL START S/W (A/T)
 1-2, 2-3: CLOSED WITH A/T SHIFT LEVER IN P OR N POSITION

(I) COLD START INJECTOR
 2-1: 12 VLOTS WHILE START INJECTOR TIME S/W IS CLOSED AND STARTER CRANKING

(J) START INJECTOR TIME S/W
 POINTS OPEN ABOVE 35°C (95°F)
 2-1: APPROX. 20-40Ω BELOW 30°C (86°F)
 2-1: APPROX. 40-60Ω ABOVE 40°C (104°F)
 2-GROUND: APPROX. 20-80Ω

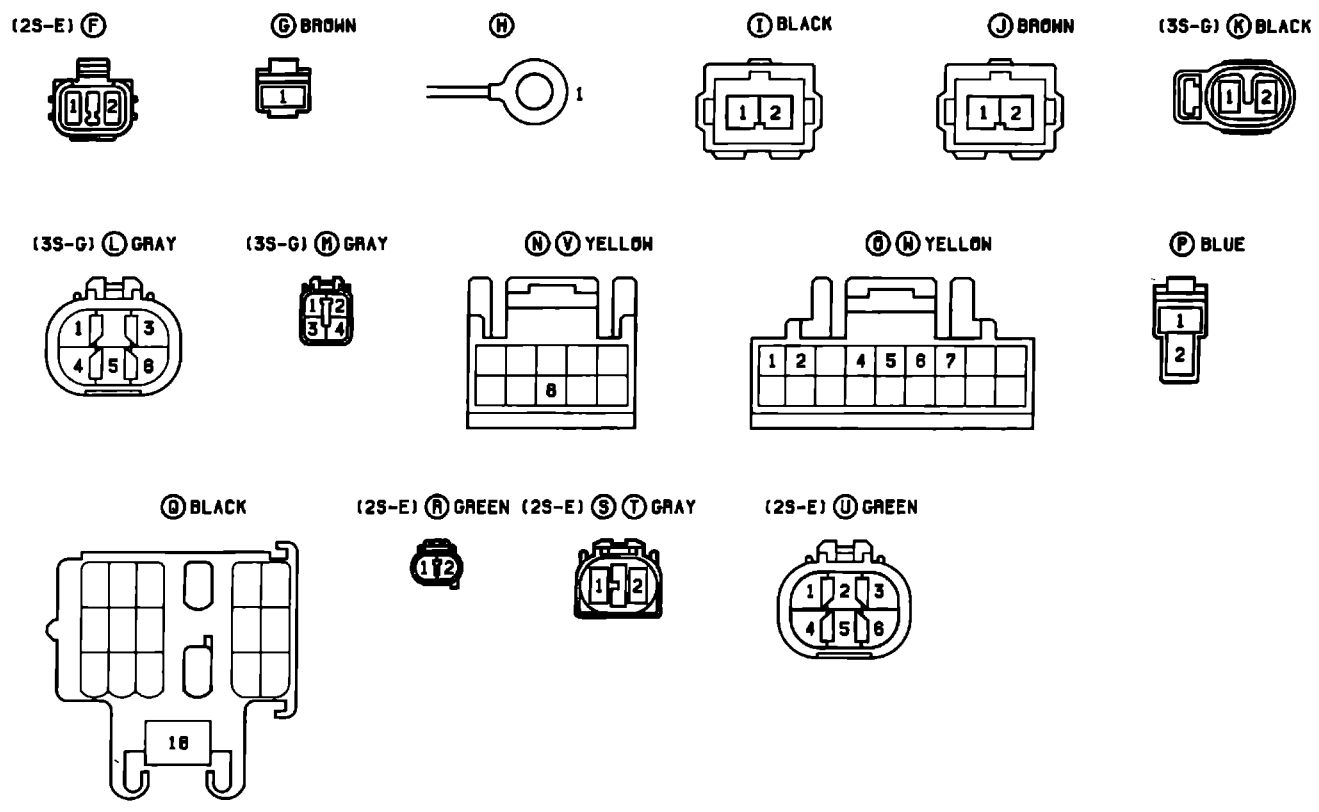
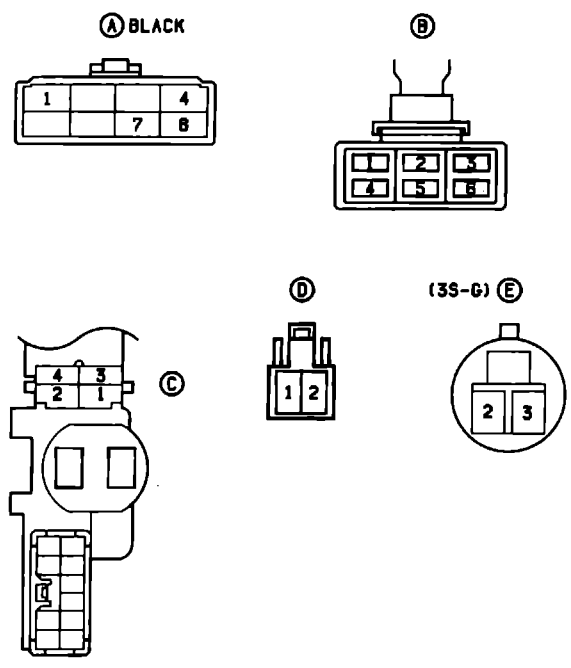

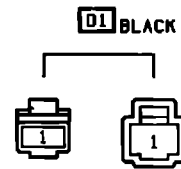
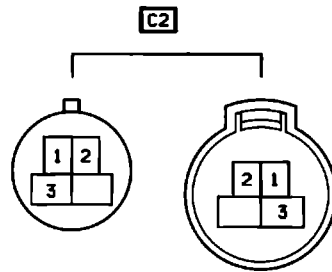
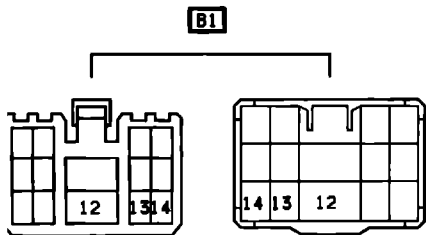
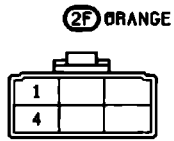
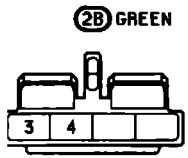
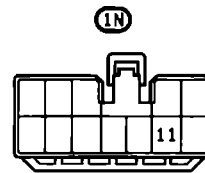
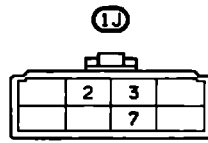
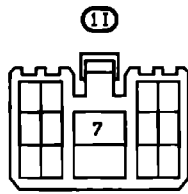
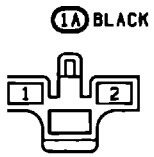

3 CHARGING SYSTEM

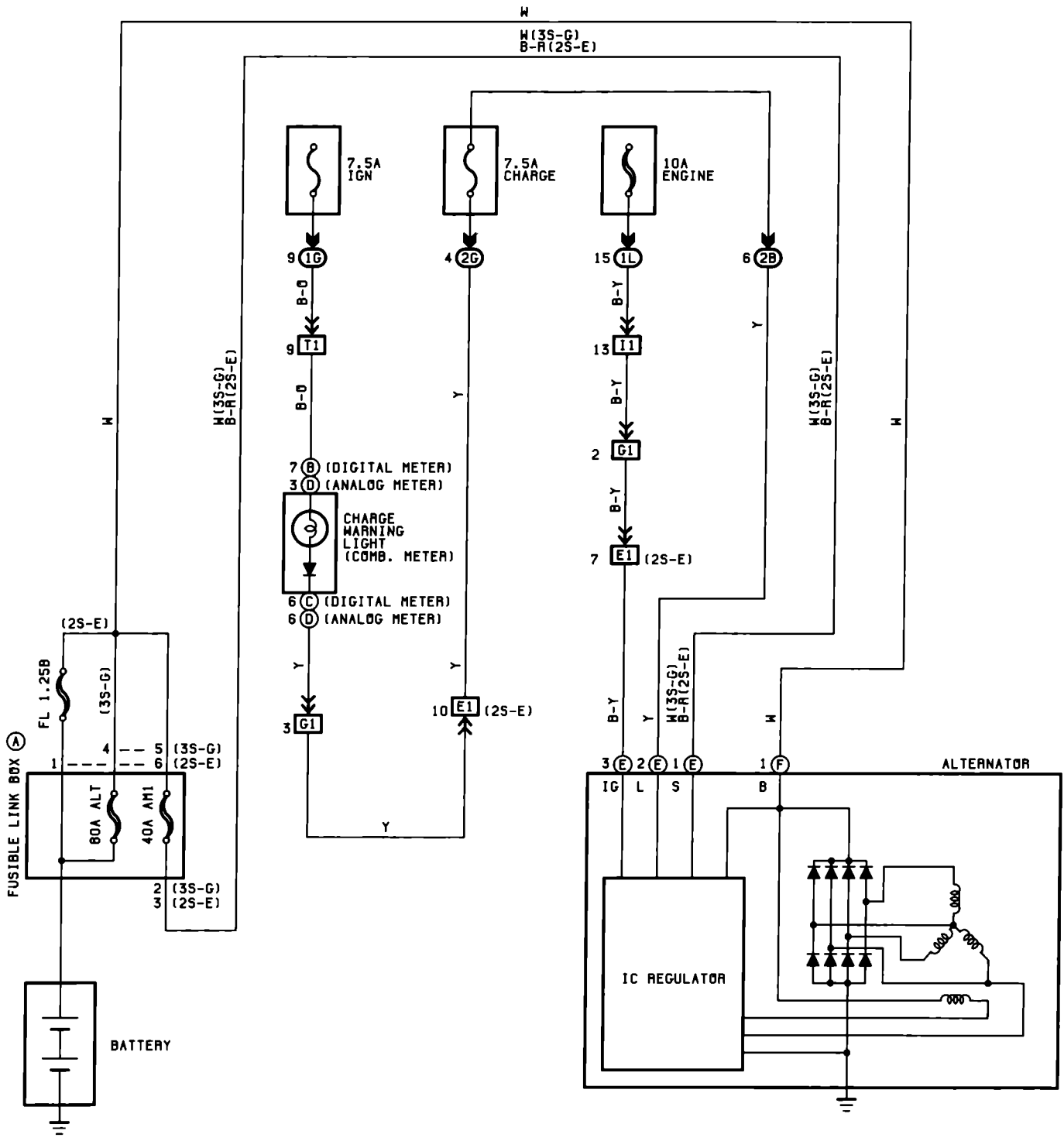

ALTERNATOR

- Ⓔ 1-GROUND: 13.5-15.1 VOLTS WITH ENGINE RUNNING AT 2000RPM
- Ⓔ 2-GROUND: 0-4 VOLTS WITH IGNITION S/W AT IG POSITION AND ENGINE NOT RUNNING

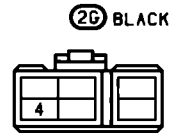
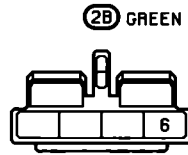
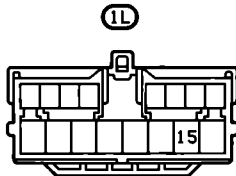
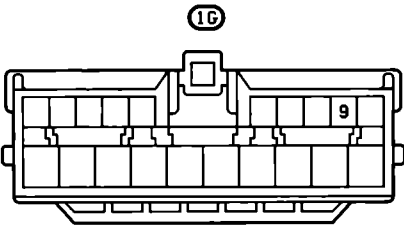
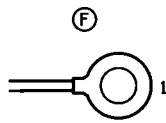
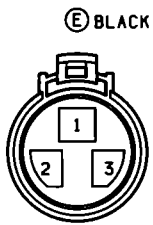
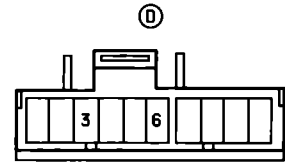
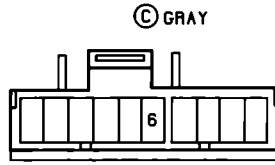
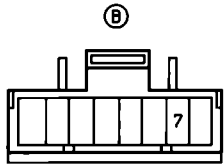
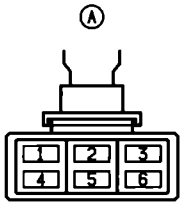

E1 BLACK

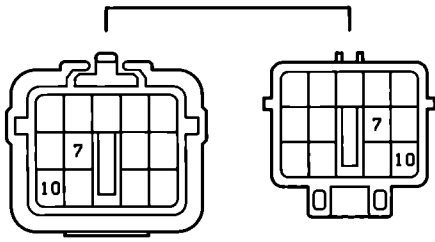

G1 YELLOW

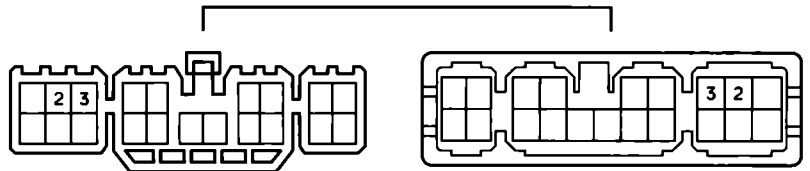

I1

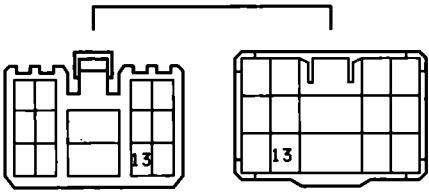

T1

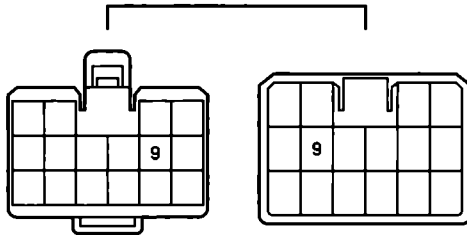

(B-0

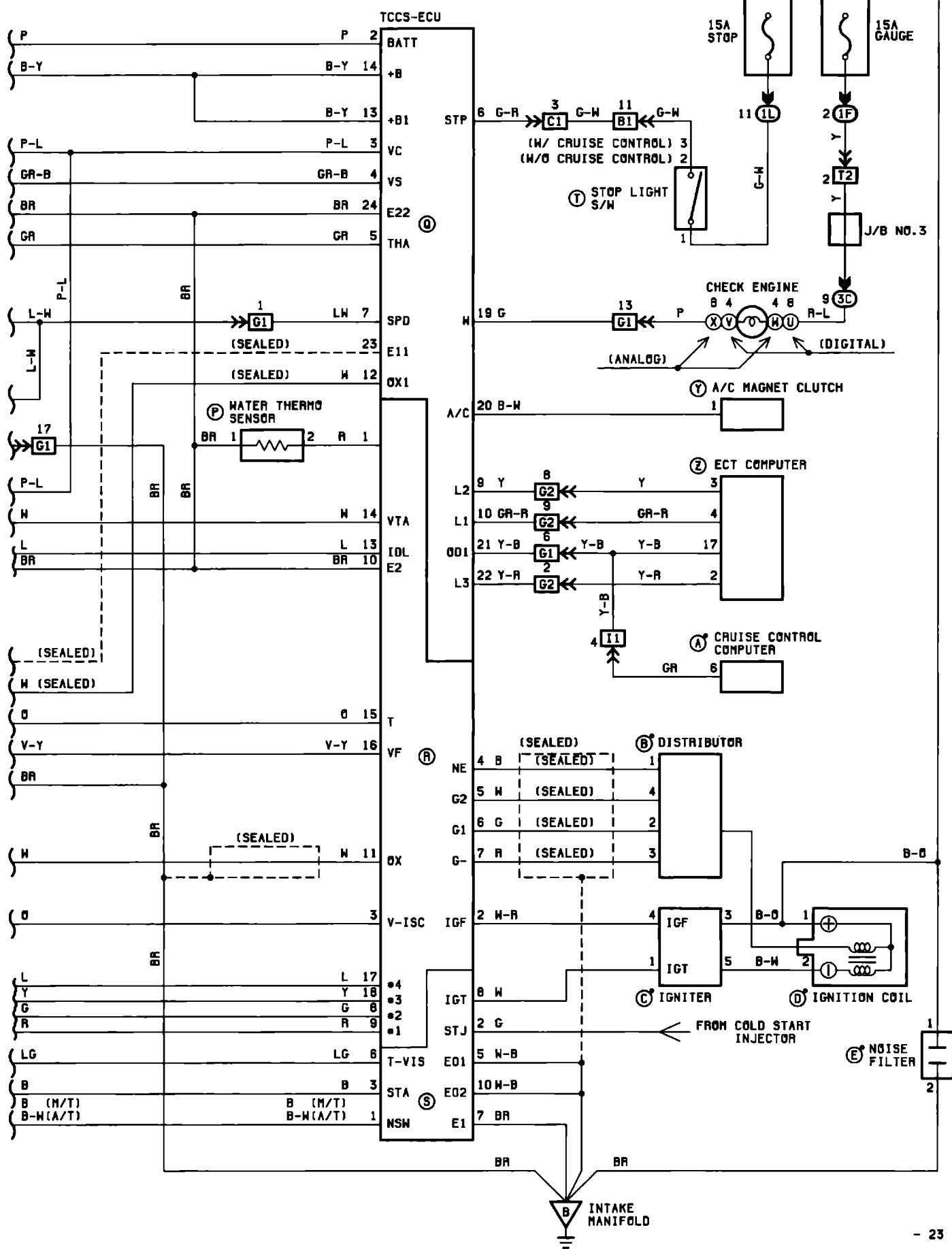

ECU (ELECTRONIC CONTROL UNIT)

VOLTAGE AT ECU CONNECTORS

ⓐ 2- Ⓢ 7	: 10-14 VOLTS
ⓐ 13- ⓐ 14- Ⓢ 7	: 10-14 VOLTS
Ⓡ 13- Ⓡ 10	: 3-5 VOLTS (IGNITION S/W ON, THROTTLE VALVE OPEN)
Ⓡ 14- Ⓡ 10	: 4-8 VOLTS (IGNITION S/W ON, THROTTLE VALVE CLOSED)
ⓐ 3- Ⓡ 10	: 4-8 VOLTS (IGNITION S/W ON)
ⓐ 4- Ⓡ 10	: 4-5 VOLTS (IGNITION S/W ON, MEASURING PLATE FULLY CLOSED) 0.02-0.08 VOLTS (IGNITION S/W ON, MEASURING PLATE FULLY OPEN) 2.0-4.0 VOLTS (IDLING)
ⓐ 5- Ⓡ 10	: 1.0-2.0 VOLTS (IGNITION S/W ON, INTAKE AIR TEMP. 20°C (68°F))
Ⓡ 1- Ⓡ 10	: 0.1-0.5 VOLTS (IGNITION S/W ON, COOLANT TEMP. 80°C (176°F))
Ⓢ 3- Ⓢ 7	: 8-12 VOLTS (IGNITION S/W ST POSITION)
Ⓡ 8, Ⓡ 17- Ⓢ 10, Ⓡ 9, Ⓡ 18- Ⓢ 5	: 10-14 VOLTS (IGNITION S/W ON) 12-18 VOLTS (IDLING) 11-15 VOLTS (3000 RPM)
Ⓢ 8- Ⓢ 7	: 0.7-1.0 VOLTS (IDLING)
Ⓢ 1- Ⓢ 7	: 0 VOLT WITH IGNITION S/W ON, SHIFT POSITION P OR N RANGE 10-14 VOLTS WITH IGNITION S/W ON, SHIFT POSITION EXCEPT P OR N RANGE 0 VOLT WITH IGNITION S/W ON (M/T) 9-11 VOLTS WITH CRANKING
Ⓡ 15- Ⓢ 7	: 4-6 VOLTS WITH IGNITION S/W ON CHECK CONNECTOR T-E1 NOT SHORT 0 VOLT WITH IGNITION S/W ON, CHECK CONNECTOR T-E1 SHORT
ⓐ 20- Ⓢ 7	: 10-13 VOLTS WITH IGNITION S/W ON A/C SWITCH ON 0 VOLT WITH IGNITION S/W ON A/C SWITCH OFF
Ⓡ 16- Ⓢ 7	: 0-5 VOLTS WITH ENGINE START (THROTTLE VALVE OPEN)
ⓐ 19- Ⓢ 7	: 0 VOLT WITH IGNITION S/W ON 10-13 VOLTS WITH ENGINE START

RESISTANCE AT ECU CONNECTOR

(DISCONNECT WIRING CONNECTOR FROM ECU)

Ⓡ 13- Ⓢ 7	: ∞ Ω (THROTTLE VALVE OPEN) LESS THAN 2500 Ω (THROTTLE VALVE FULLY CLOSED)
Ⓡ 14- Ⓢ 7	: 3500-10000 Ω (THROTTLE VALVE OPEN) 200-800 Ω (THROTTLE VALVE FULLY CLOSED)
ⓐ 3- Ⓡ 10	: 3000-7000 Ω
ⓐ 4- Ⓡ 10	: 20-400 Ω (MEASURING PLATE FULLY CLOSED) 20-1000 Ω (MEASURING PLATE FULLY OPEN)
ⓐ 5- Ⓡ 10	: 2000-3000 Ω (INTAKE AIR TEMP. 20°C, 68°F)

EFI MAIN RELAY

CLOSED WITH IGNITION S/W AT IG OR ST POSITION

ⓑ ⓐ INJECTOR

1-2: EACH APPROX. 13.8 Ω

ⓕ CIRCUIT OPENING RELAY

1-2: CLOSED WITH STARTER RUNNING
OR MEASURING PLATE (AIR FLOW METER) OPEN

ⓗ AIR FLOW METER

1-2: CLOSED WITH STARTER RUNNING OR MEASURING PLATE OPEN
5-8: 200-600 Ω (MEASURING PLATE CLOSED)
200-1200 Ω (MEASURING PLATE OPEN)
5-4: 200-400 Ω
5-7: 10-20 K Ω (-20°C, -4°F)
4-7 K Ω (0 C, 32°F)
2-3 K Ω (20°C, 68°F)
0.8-1.3 K Ω (40°C, 104°F)
0.4-0.7 K Ω (60°C, 140°F)

Ⓡ THROTTLE POSITION SENSOR

2-4: 0.2-0.8 K Ω WITH CLEARANCE BETWEEN LEVER AND STOP SCREW 0MM (0 IN.)
3-4: LESS THAN 2.3 K Ω WITH CLEARANCE BETWEEN LEVER AND STOP SCREW 0.35 MM (0.0138 IN)
∞ Ω WITH 0.59 MM (0.0232 IN)
2-4: 3.3-10 K Ω WITH THROTTLE VALVE FULLY OPEN
1-4: 3-7 K Ω

ⓕ WATER THERMO SENSOR

1-2: APPROX. 8 K Ω (0°C, 32°F)
APPROX. 1.5 K Ω (40°C, 104°F)
APPROX. 0.5 K Ω (80°C, 176°F)

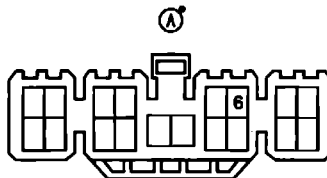
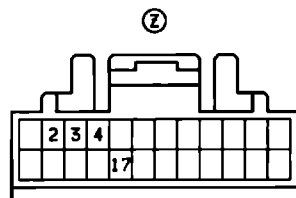
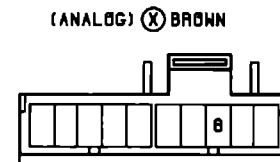
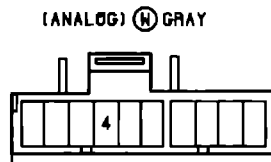
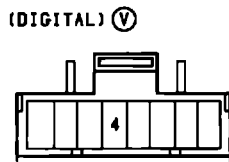
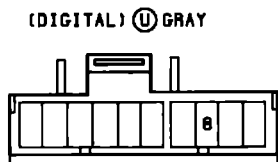
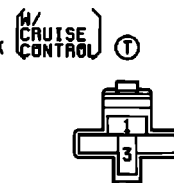
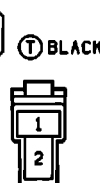
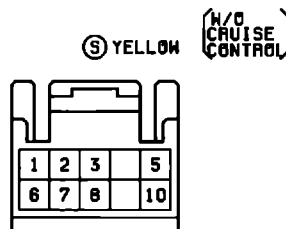
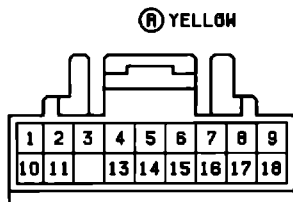
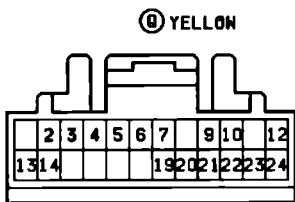
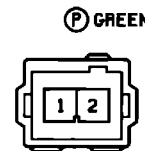
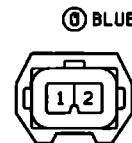
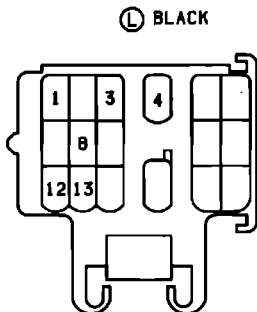
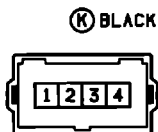
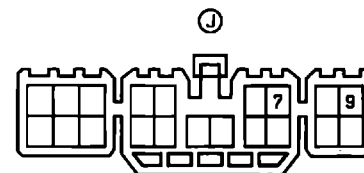
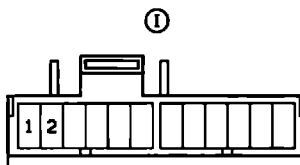
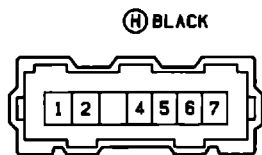
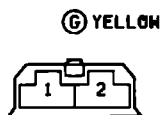
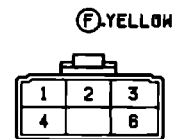
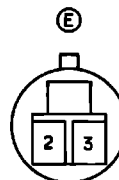
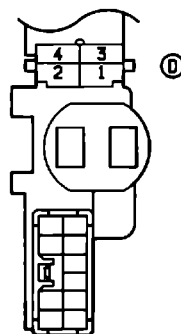
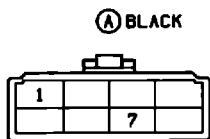

4-1 **EFI** SYSTEM (3S-G)

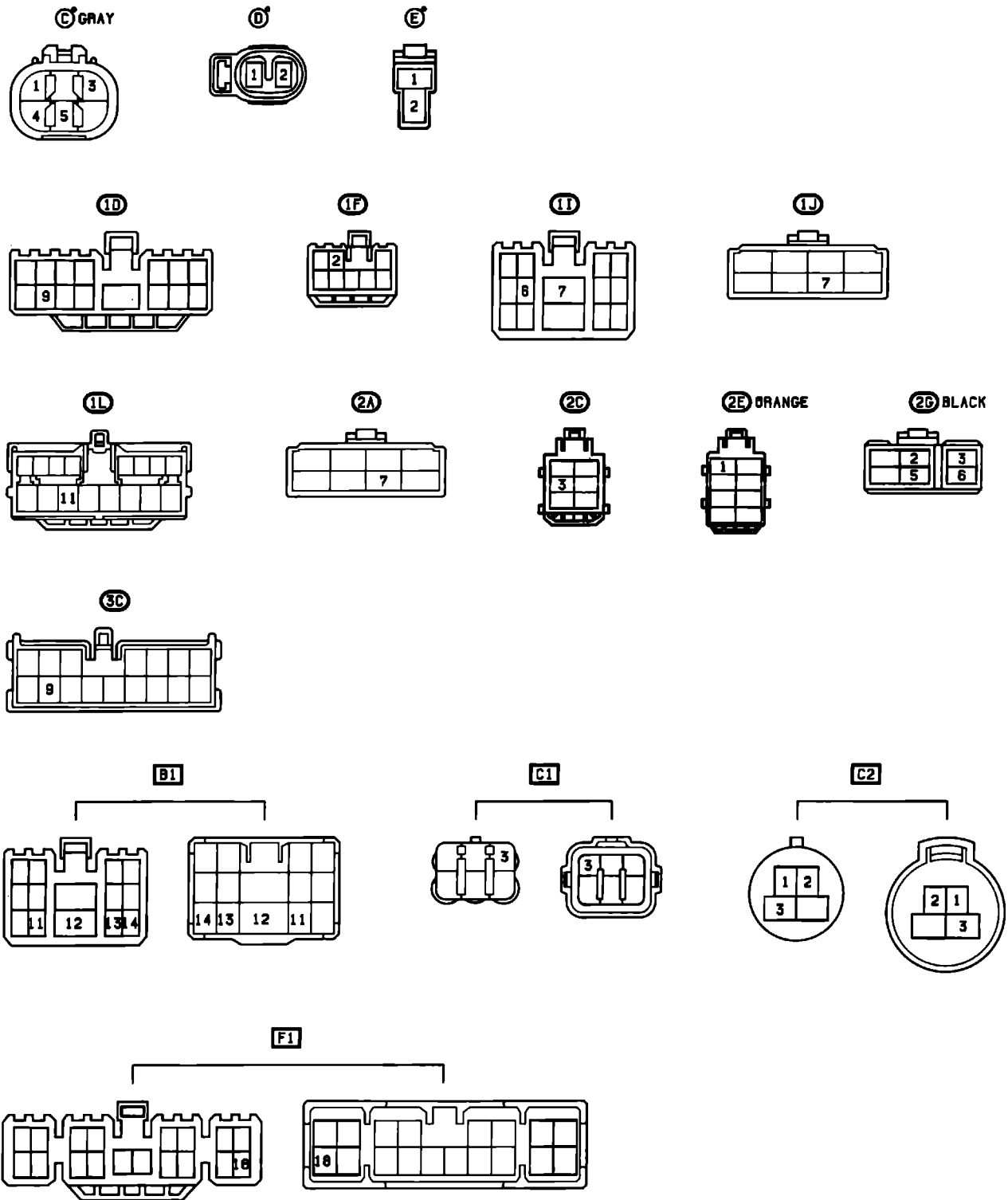

G1 YELLOW

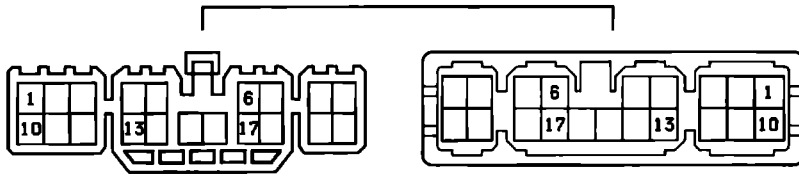

G2

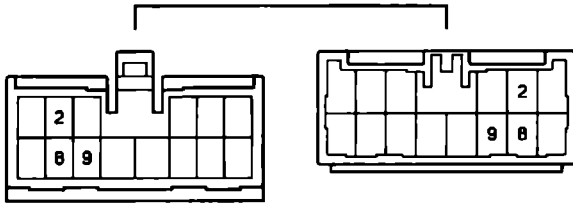

I1

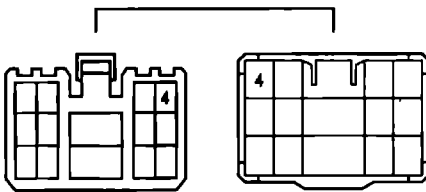

N1

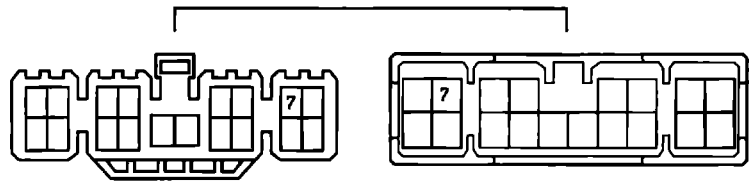

T2

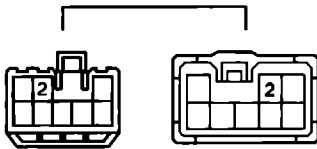

4-2 EFI SYSTEM (2S-E)

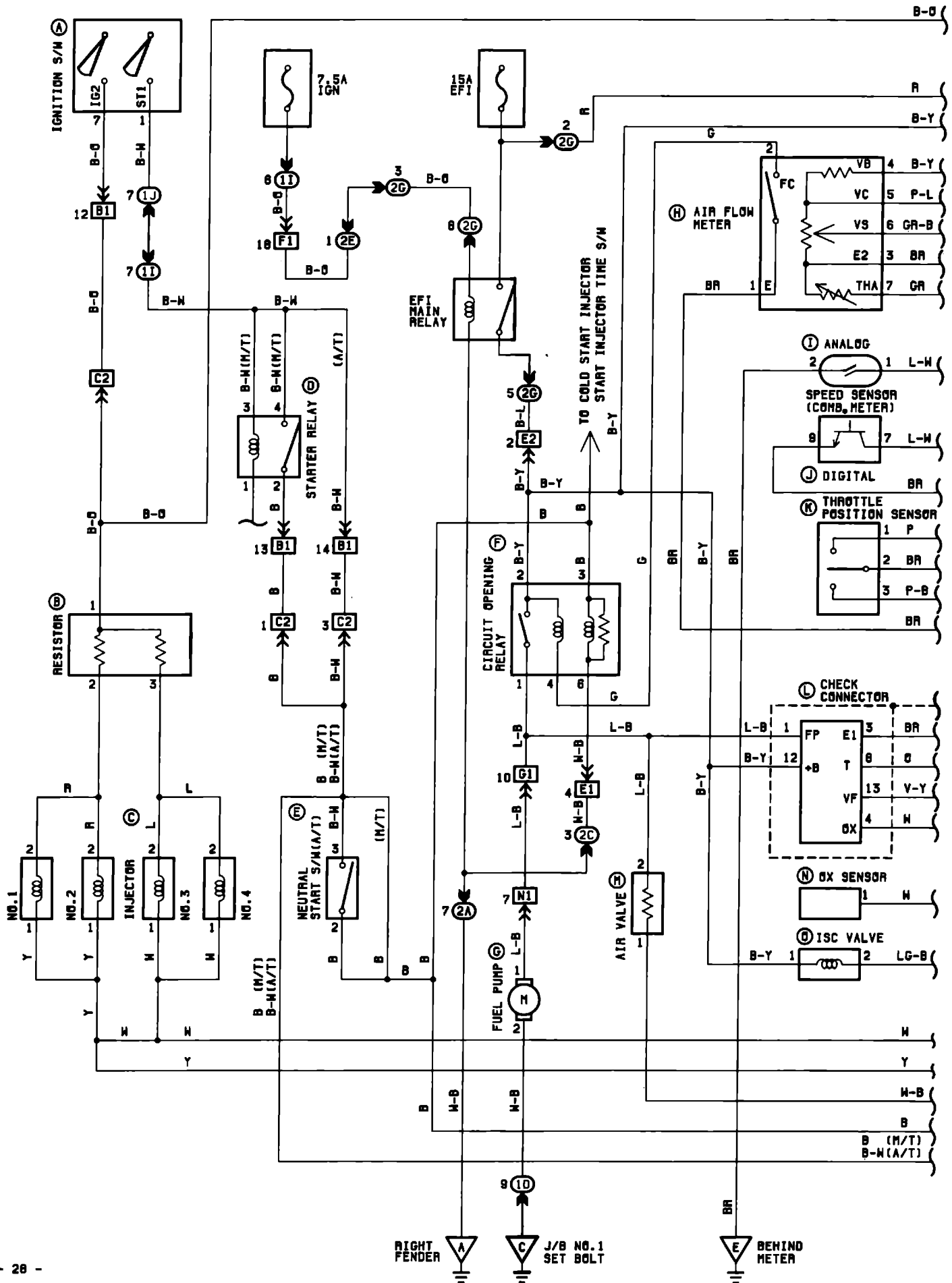

EFI MAIN RELAY

CLOSED WITH IGNITION S/W AT 1G OR ST POSITION

(B) RESISTOR

1-2, 1-3: EACH 2.0-3.0Ω

(C) INJECTOR

1-2: EACH 1.5-3.0Ω

(D) STARTER RELAY

2-4: CLOSED WITH CLUTCH PEDAL FULLY DEPRESSED AND IGNITION S/W AT ST POSITION

(E) CIRCUIT OPENING RELAY

CLOSED WITH STARTER RUNNING OR MEASURING PLATE (AIR FLOW METER) OPEN

(H) AIR FLOW METER

1-2: CLOSED WITH STARTER RUNNING OR MEASURING PLATE OPEN

3-8: 20-400Ω (MEASURING PLATE FULLY CLOSED)

20-1000Ω (MEASURING PLATE FULLY OPEN)

3-4: 200-400Ω

3-5: 100-300Ω

3-7: 10-20KΩ (-20°C, -4°F)

4-7KΩ (0°C, 32°F)

2-3KΩ (20°C, 68°F)

0.9-1.3KΩ (40°C, 104°F)

0.4-0.7KΩ (80°C, 140°F)

(K) THROTTLE POSITION SENSOR

2-1: CLOSED WITH THROTTLE VALVE CLOSED

2-3: CLOSED WITH THROTTLE VALVE FULLY OPEN

(P) WATER THERMO SENSOR

1-2: 10-20KΩ (-20°C, -4°F)

4-7KΩ (0°C, 32°F)

2-3KΩ (20°C, 68°F)

0.9-1.3KΩ (40°C, 104°F)

0.4-0.7KΩ (80°C, 140°F)

0.2-0.4KΩ (80°C, 176°F)

ECU (ELECTRONIC CONTROLLED UNIT)

VOLTAGES AT ECU CONNECTORS

(Q) 2-(S) 7: 10-14 VOLTS (ALWAYS)

(Q) 1, 6-(S) 7: 10-14 VOLTS

(R) 6-(S) 7: 8-14 VOLTS (THROTTLE VALVE OPEN)

(R) 11-(S) 7: 8-14 VOLTS (THROTTLE VALVE FULLY CLOSED)

(S) 4, 9-(S) 7: 10-14 VOLTS

(Q) 3-(Q) 12: 1-3 VOLTS (INTAKE AIR TEMP. 20°C, 68°F)

(R) 10-(Q) 12: 0.1-1.0 VOLTS COOLANT TEMP. 80°C, 176°F

(S) 3-(S) 7: 6-14 VOLTS (IGNITION S/W ST) 68

(S) 8-(S) 7: 0.7-1.0 VOLTS (IDLING) 176

(R) 8-(S) 7: 0VOLT
10-13 VOLTS (START ENGINE)

(R) 15-(S) 7: 10-13 VOLTS (A/C S/W ON)
0VOLT (A/C S/W OFF)

(Q) 5-(Q) 12: 6-10 VOLTS (IGNITION S/W ON)

(Q) 4-(Q) 12: 0.5-2.5 VOLTS (MEASURING PLATE, FULLY CLOSED)
10 VOLTS (ENGINE RUNNING)
MEASURING PLATE FULLY OPEN
2-8 VOLTS (IDLING)

RESISTANCE AT COMPUTER WIRING CONNECTOR

(DISCONNECT WIRING CONNECTOR)

(R) 6-(Q) 12: ∞Ω (THROTTLE VALVE OPEN)
LESS THAN 2.3KΩ (THROTTLE VALVE FULLY CLOSED)

(Q) 5-(Q) 12: 100-300Ω

(Q) 3-(Q) 12: 2-3KΩ (INTAKE AIR TEMP. 20°C, 68°F)

(R) 10-(Q) 12: 0.2-0.4KΩ (COOLANT TEMP. 80°C, 176°F)

(Q) 4-(Q) 12: 20-400Ω MEASURING PLATE FULLY CLOSED
20-3000Ω MEASURING PLATE FULLY OPEN

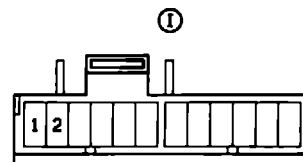
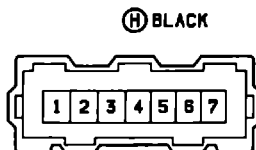
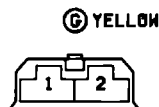
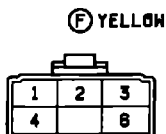
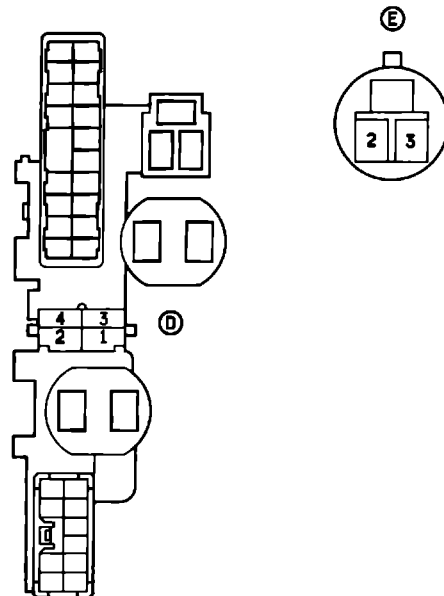
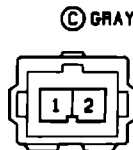
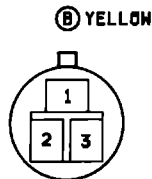
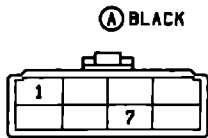

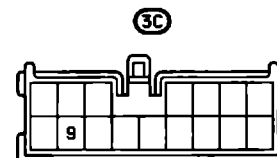
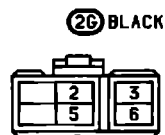
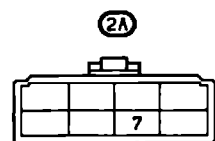
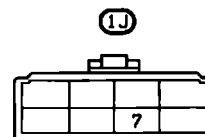
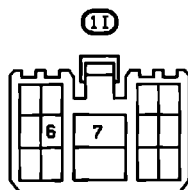
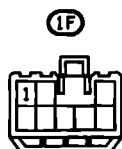
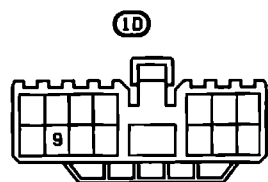
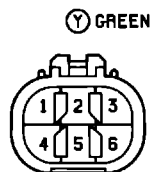
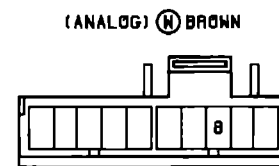
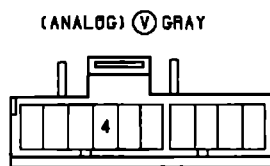
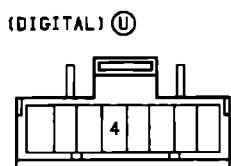
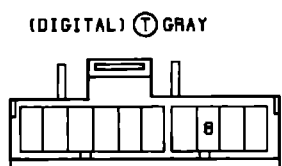
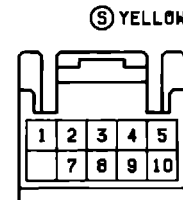
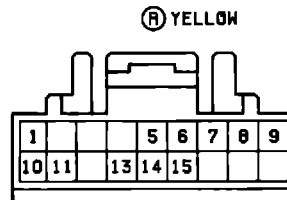
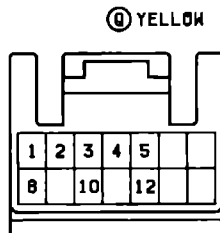
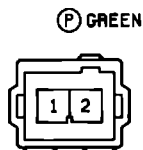
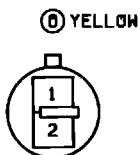
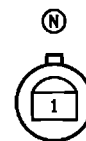
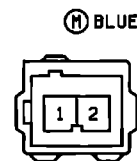
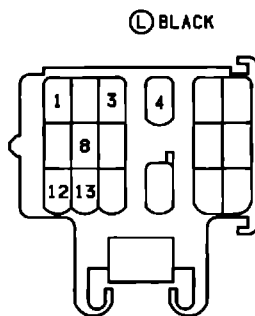
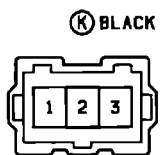
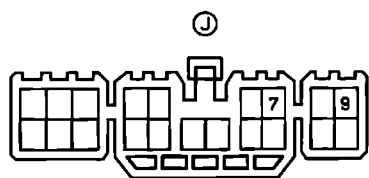

4-2 **EFI** EFI SYSTEM (2S-E)

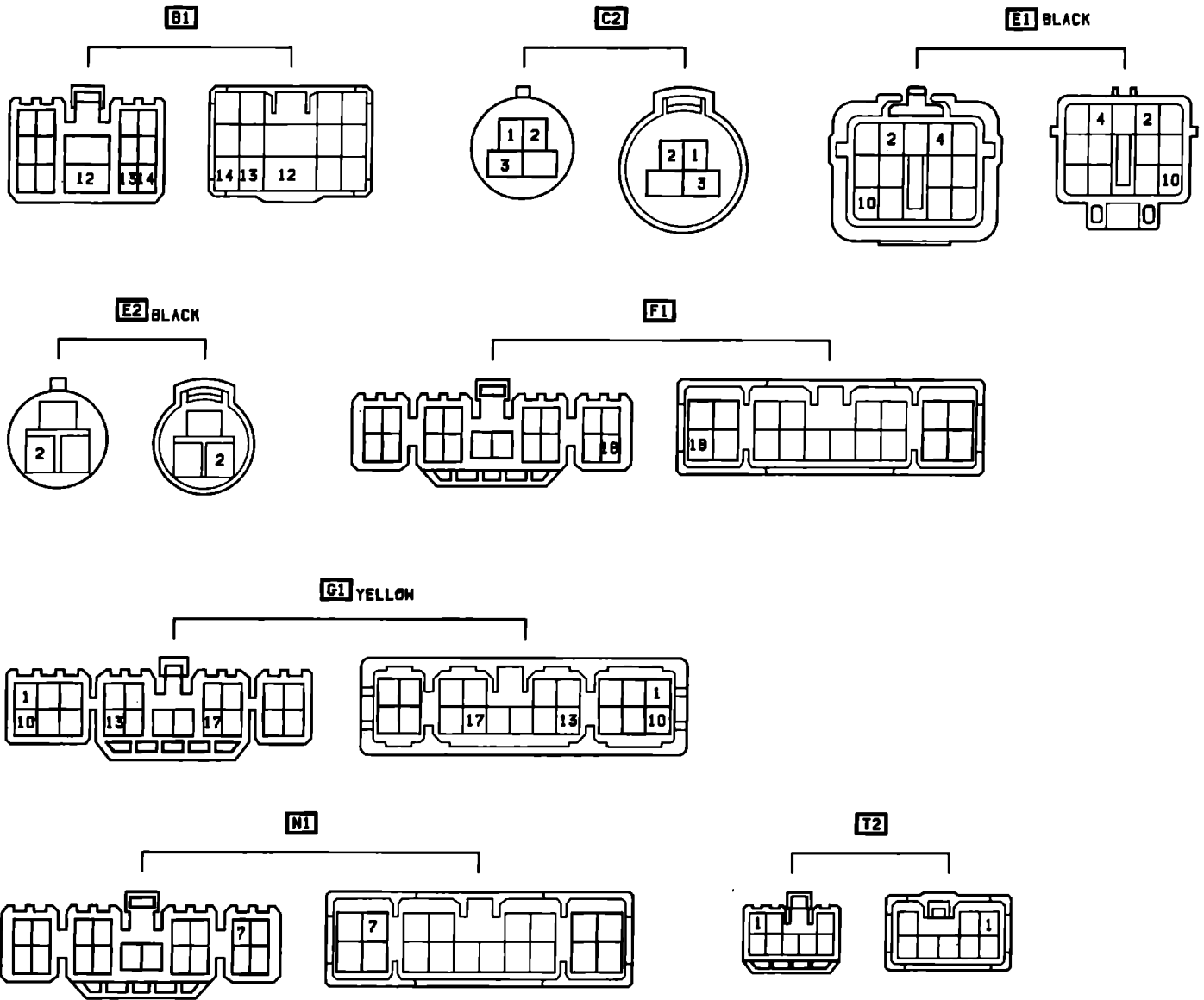

(A) INTEGRATION RELAY NO.2

2-GROUND,10-GROUND: APPROX. 12 VOLTS WITH LIGHT CONTROL S/W OFF
(HEADLIGHT,TAILLIGHT OFF)

10-GROUND : 0 VOLT WITH LIGHT CONTROL S/W A/T HEAD POSITION(TAILLIGHTS ON)
(HEADLIGHTS ON)

2-GROUND : 0 VOLT WITH LIGHT CONTROL S/W A/T TAIL POSITION(TAILLIGHTS ON)

2-GROUND,10-GROUND: 0 VOLT WITH LIGHT CONTROL S/W A/T HEAD,TAIL POSITION AFTER
IGNITION S/W TURNED OFF AND LH DOOR OPEN

(HEADLIGHT,TAILLIGHT TURN OFF AUTOMATICALLY WHEN THE IGNITION S/W
IS TURNED OFF AND LH DOOR OPEN)

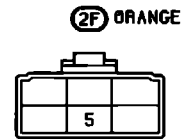
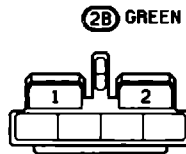
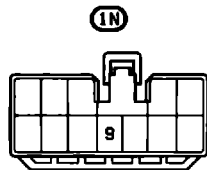
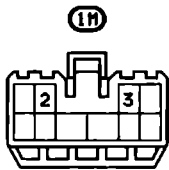
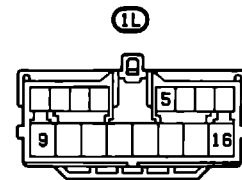
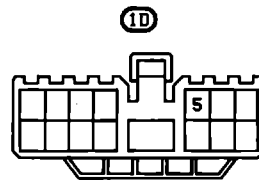
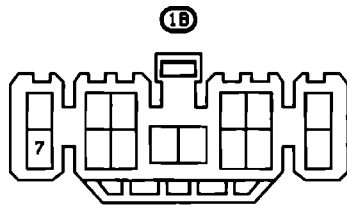
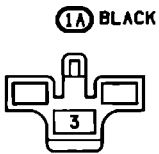
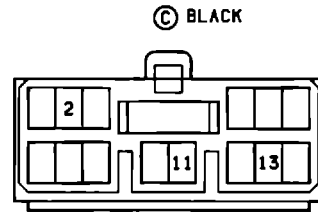
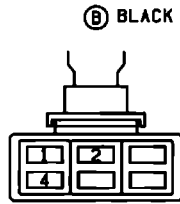
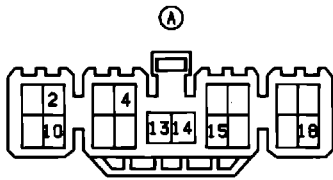

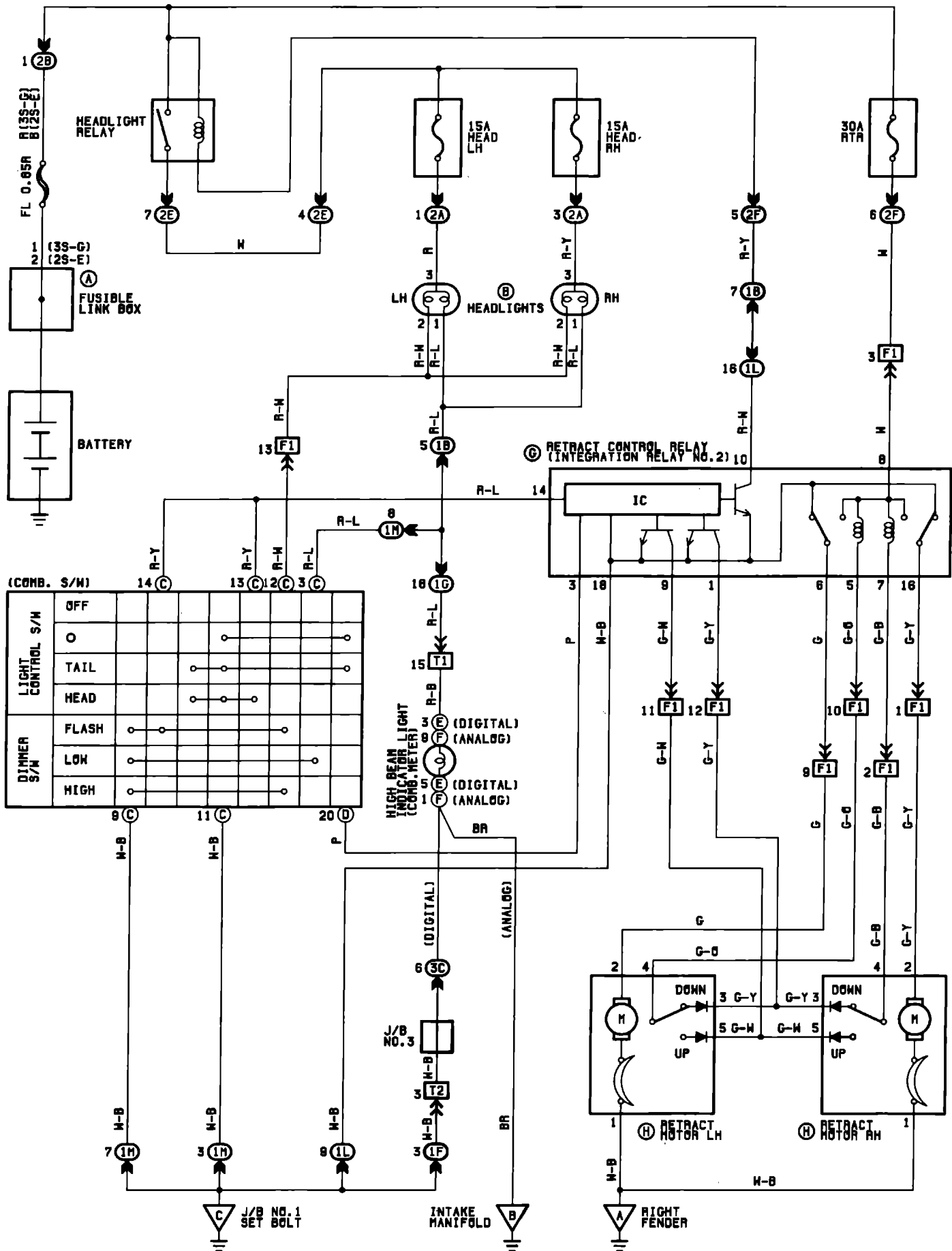

Ⓒ RETRACT CONTROL RELAY

8-GROUND: ALWAYS 12VOLTS

1-18 : CONTINUITY FOR 8-12SECONDS WITH LIGHT CONTROL S/W AT HEAD POSITION OR LIGHT CONTROL S/W AT HOLD POSITION AND DIMMER S/W AT FLASH POSITION

1-18 : CONTINUITY FOR 8-12SECONDS 1-1.5SECONDS AFTER LIGHT CONTROL S/W OFF AND DIMMER S/W AT FLASH POSITION

9-18 : CONTINUITY FOR 8-12SECONDS WITH LIGHT CONTROL S/W AT HOLD(UP POSITION) → OFF POSITION

9-18 : CONTINUITY FOR 8-12SECONDS 1-1.5SECONDS AFTER LIGHT CONTROL S/W OFF AND DIMMER S/W AT FLASH POSITION

8-6,8-18: CLOSED WITH LIGHT CONTROL S/W AT HEAD POSITION UNTIL RETRACT MOTOR AT UP POSITION

8-6,8-18: CLOSED WITH LIGHT CONTROL S/W AT OFF POSITION UNTIL RETRACT MOTOR AT DOWN POSITION

Ⓓ RETRACT MOTOR

4-5 : CLOSED UNLESS RETRACT MOTOR AT DOWN POSITION

4-3 : CLOSED UNLESS RETRACT MOTOR AT UP POSITION

LIGHT AUTO TURN-OFF OPERATION

PLEASE REFER TO THE LIGHT AUTO TURN OFF SYSTEM (SYSTEM NO.6)

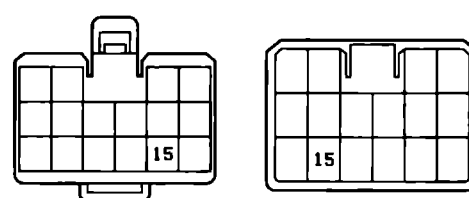
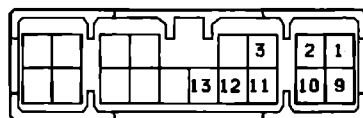
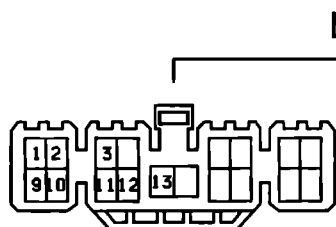
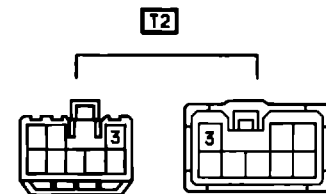
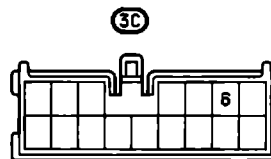
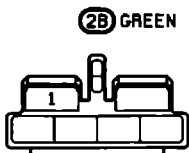
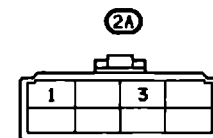
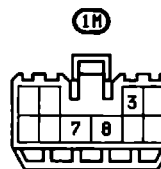
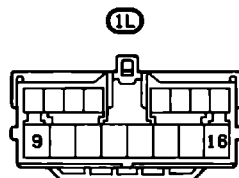
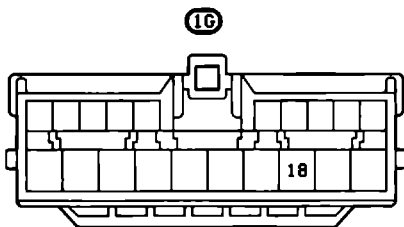
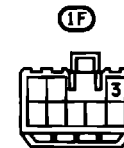
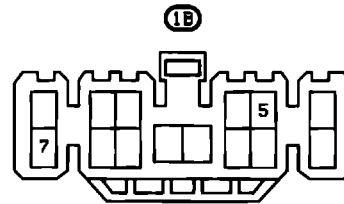
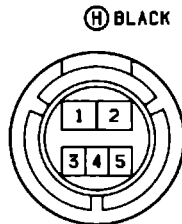
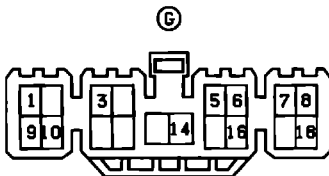
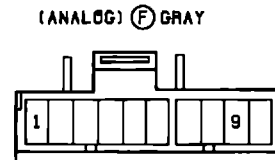
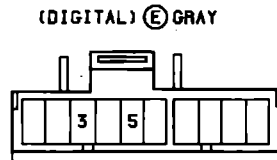
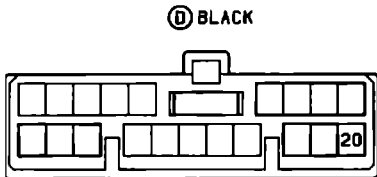
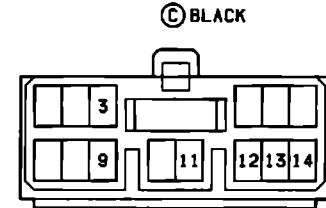
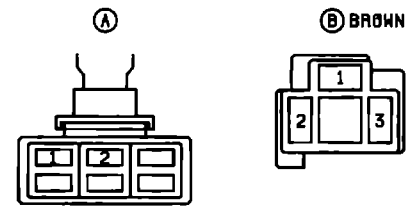

8 INTERIOR LIGHTS

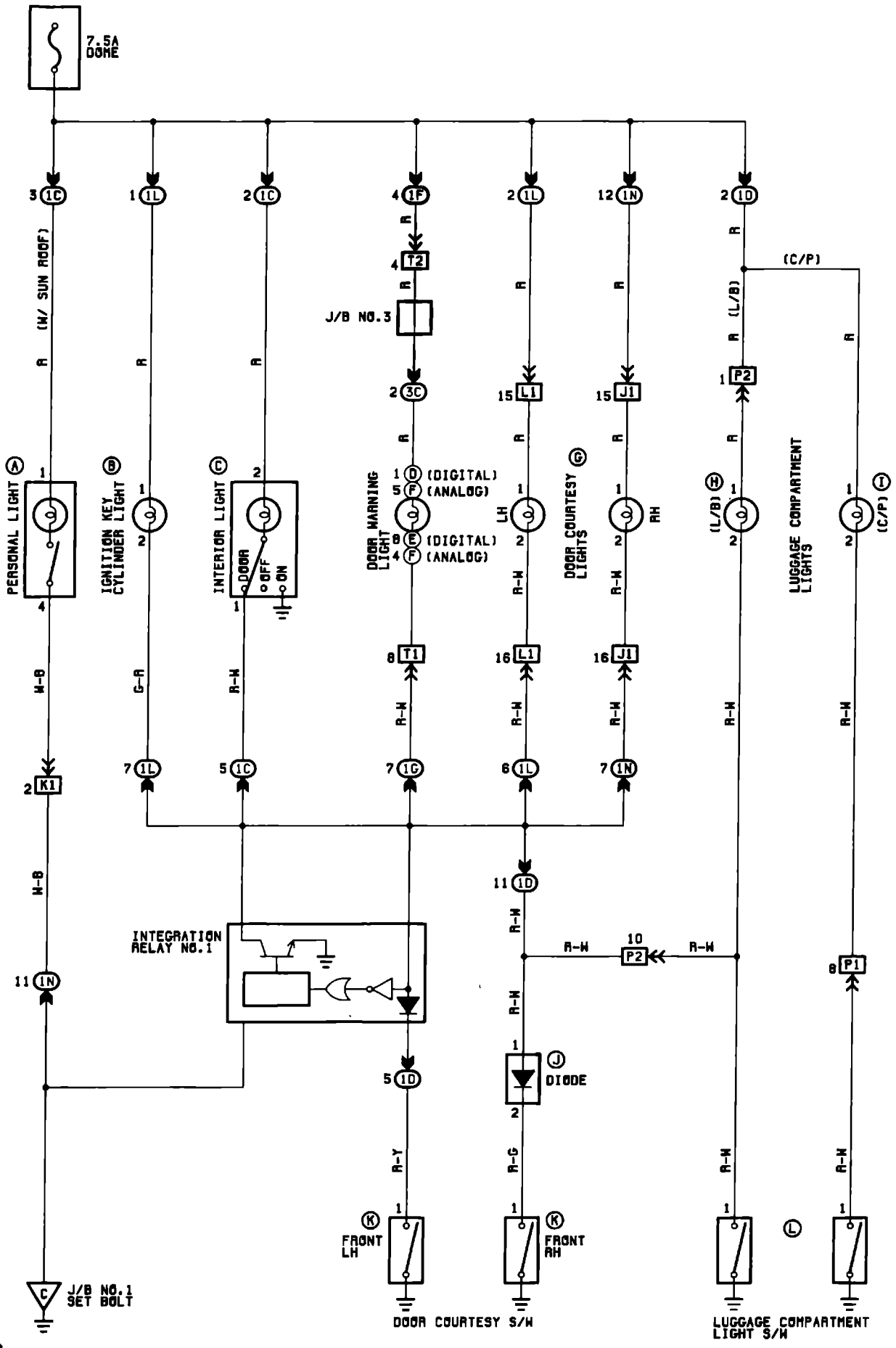

INTEGRATION RELAY NO. 1
(IC) 5-GROUND: CONTINUITY WITH DOOR OPEN AND FOR 5 SECONDS AFTER DOOR CLOSED

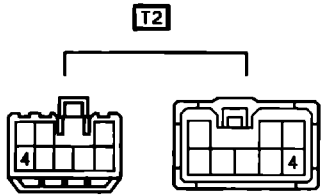
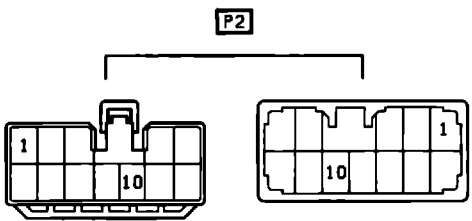
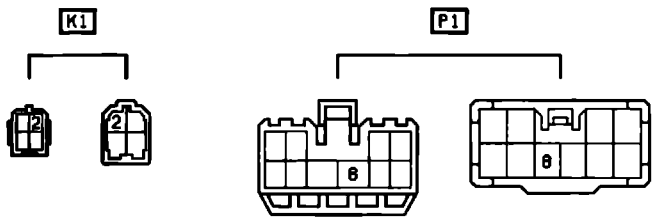
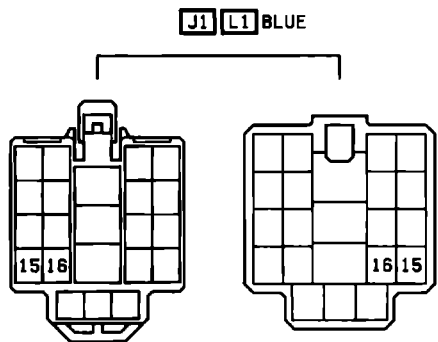
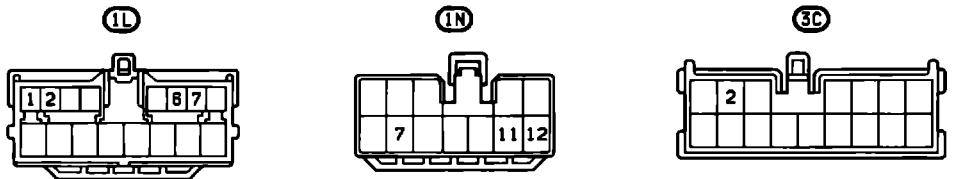
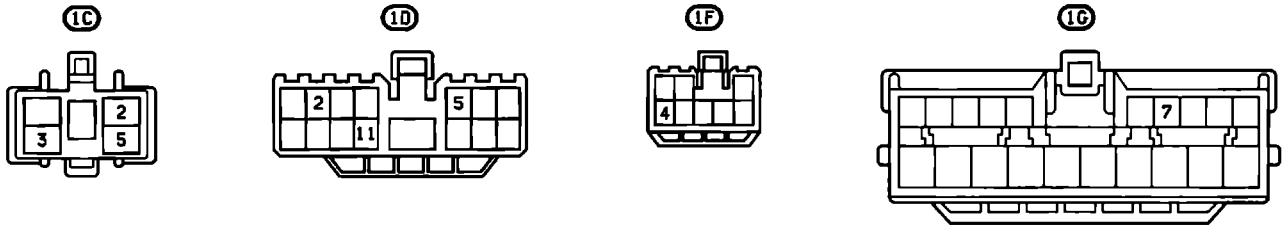
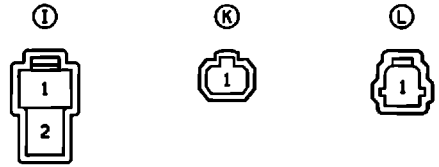
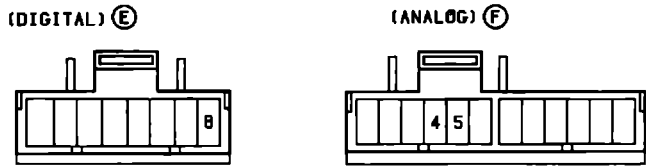
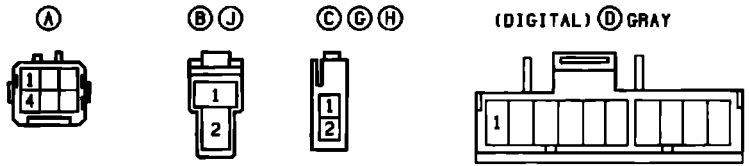

9 ILLUMINATION

TAILLIGHT RELAY

CLOSED WITH LIGHT CONTROL S/W AT TAIL OR HEAD POSITION
(LIGHT AUTO TURN OFF SYSTEM OFF)

ⓑ INTEGRATION RELAY NO.2

PLEASE REFER TO LIGHT AUTO TURN OFF SYSTEM
(SYSTEM NO.6)

RHEOSTAT

ⓐ 1-2. ⓑ 4-1: 12VOLTS WITH RHEOSTAT FULLY TURNED COUNTERCLOCKWISE
AND 0VOLT WITH FULLY TURNED CLOCKWISE

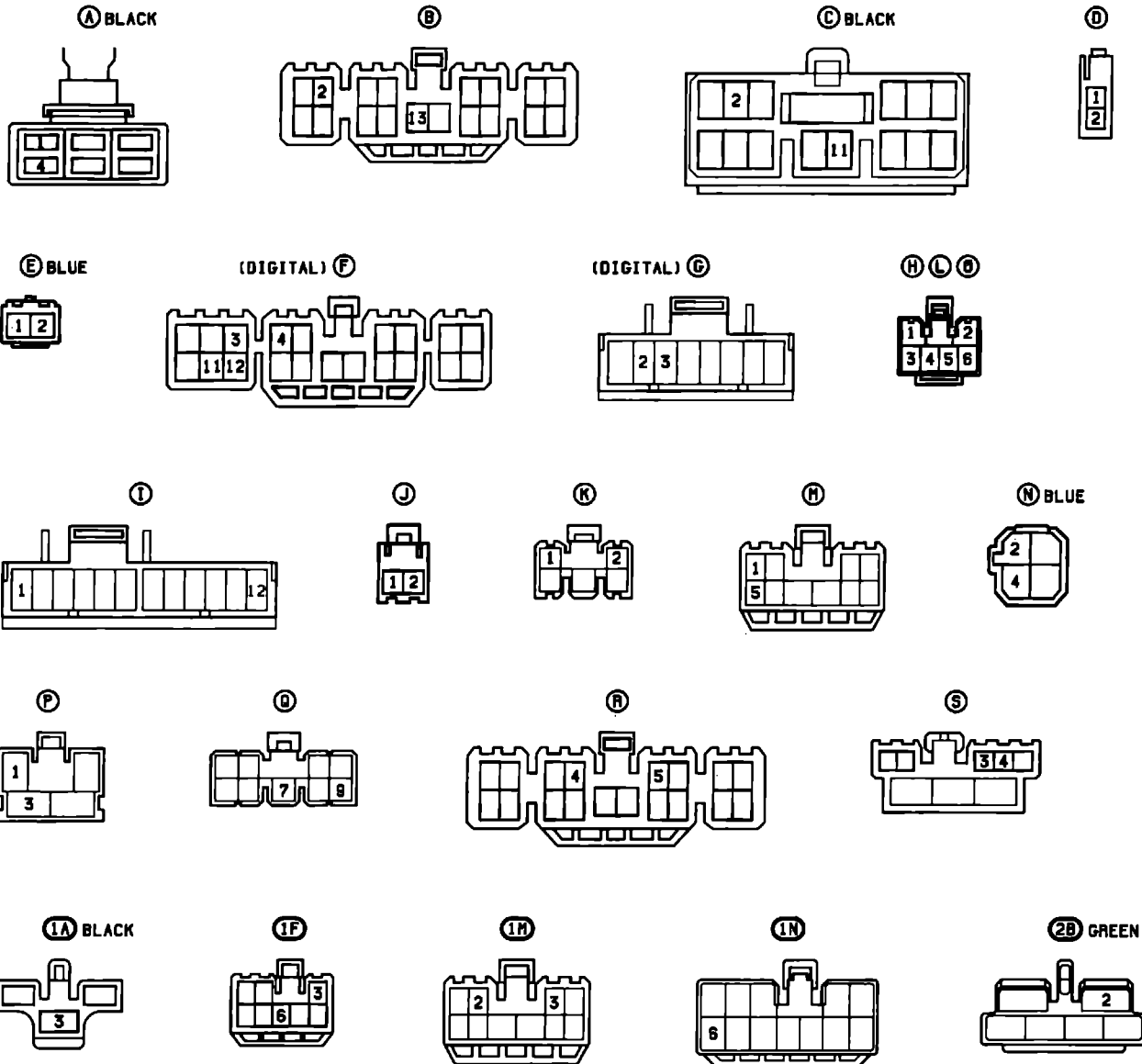

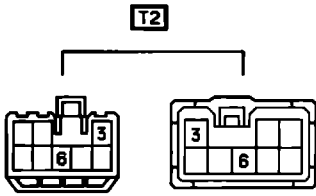
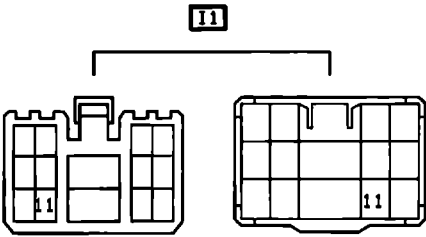
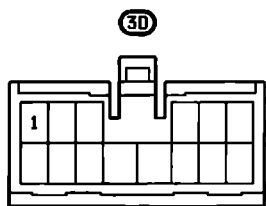
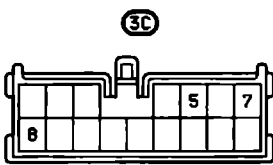
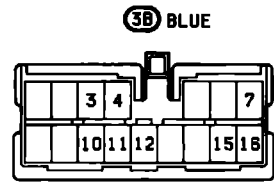
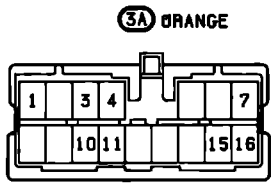

10 TAILLIGHTS

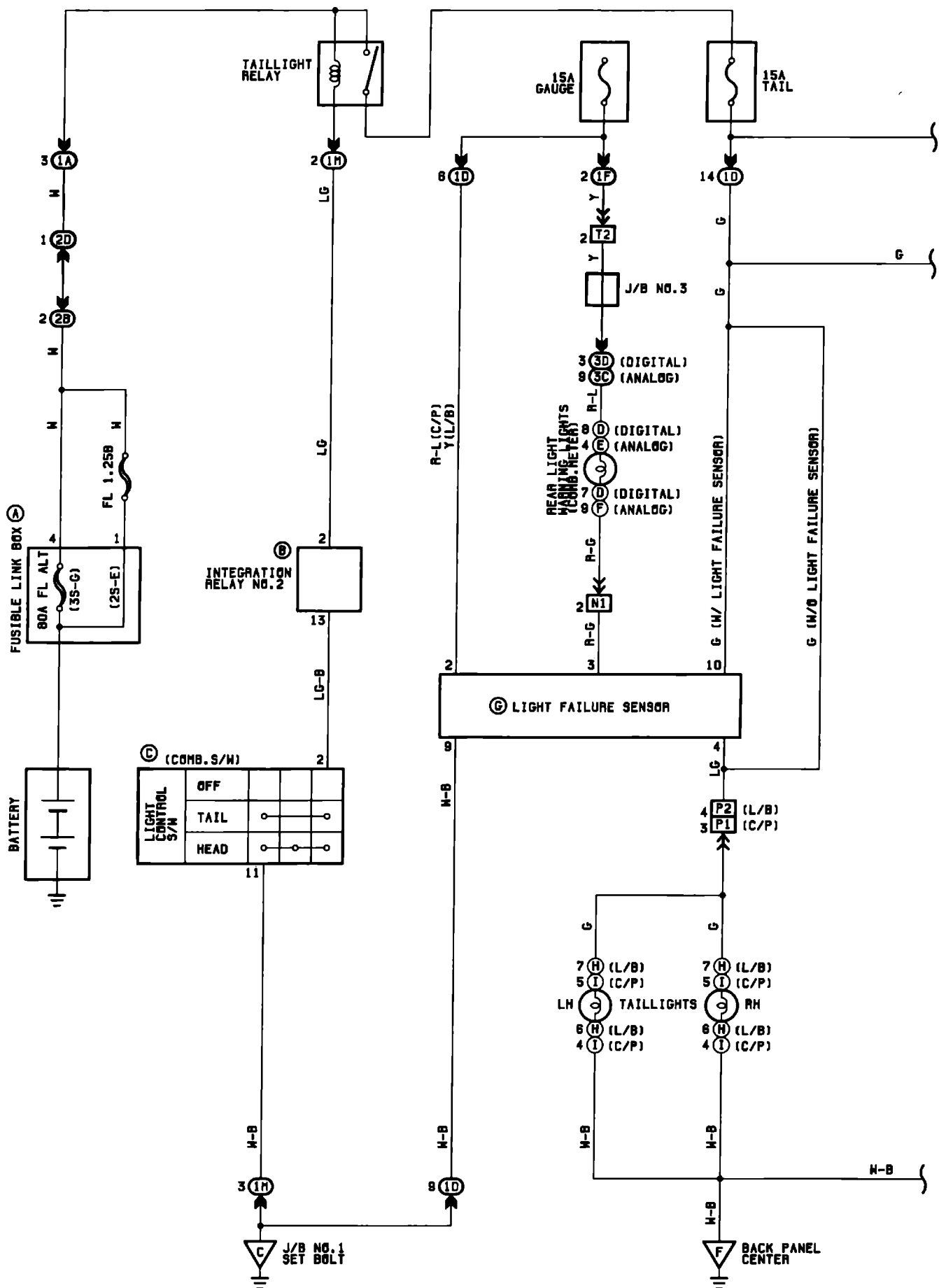

TAILLIGHT RELAY
 CLOSED WITH LIGHT CONTROL S/W AT TAIL OR HEAD POSITION
 (LIGHT RETAINER RELAY ON)

Ⓑ INTEGRATION RELAY NO.2
 PLEASE REFER TO LIGHT AUTO TURN OFF SYSTEM
 (SYSTEM NO.6)

Ⓒ LIGHT FAILURE SENSOR
 (DISCONNECT THE FAILURE SENSOR AND INSPECT THE CONNECTOR)
 10-GROUND : 12 VOLTS WITH IGNITION S/W ON, LIGHT CONTROL S/W AT
 TAIL OR HEAD POSITION
 3-GROUND : 12 VOLTS WITH ENGINE RUNNING
 2-GROUND : 12 VOLTS WITH IGNITION S/W ON
 9-GROUND : CONTINUITY
 4-GROUND : CONTINUITY

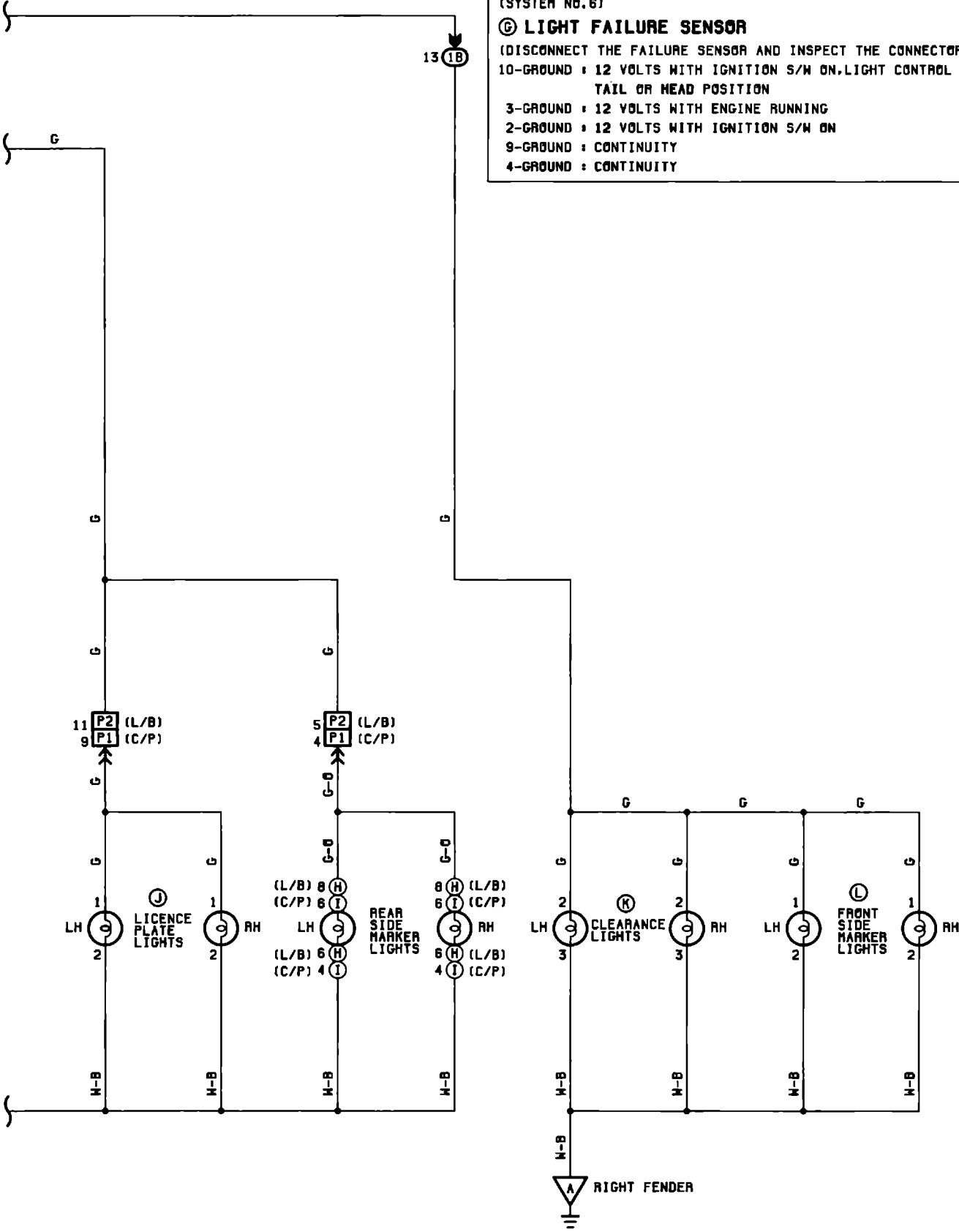

10 TAILLIGHTS

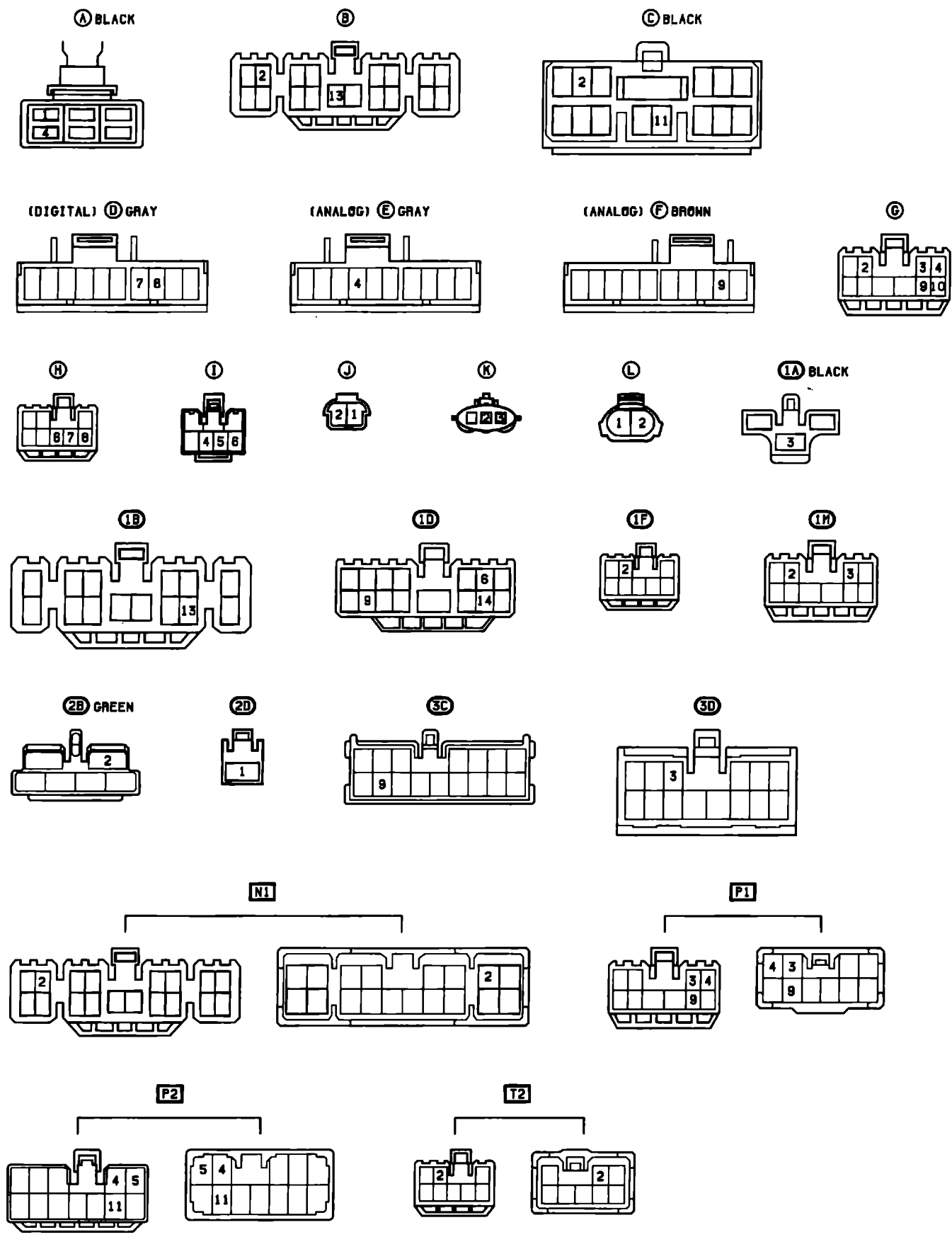

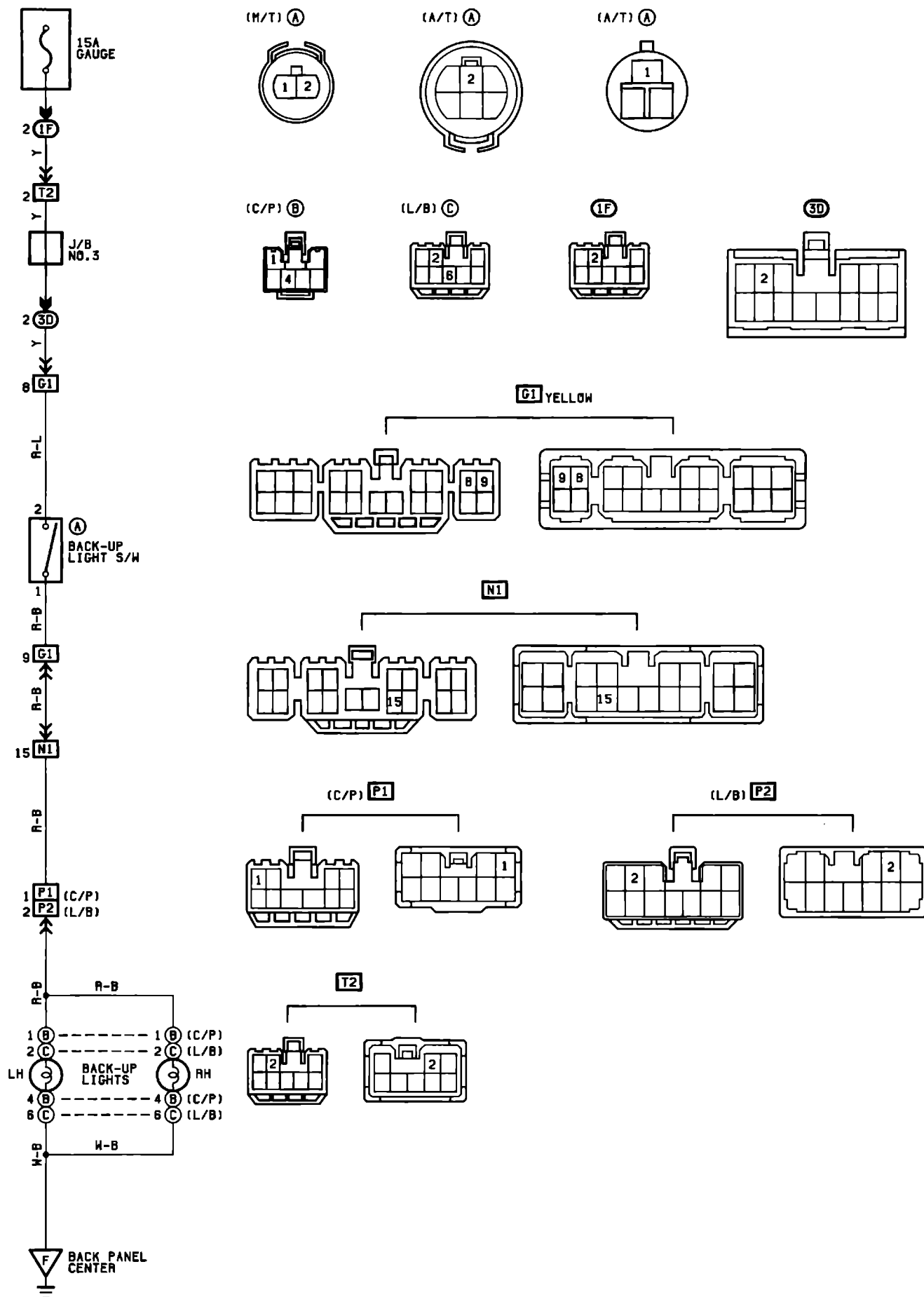

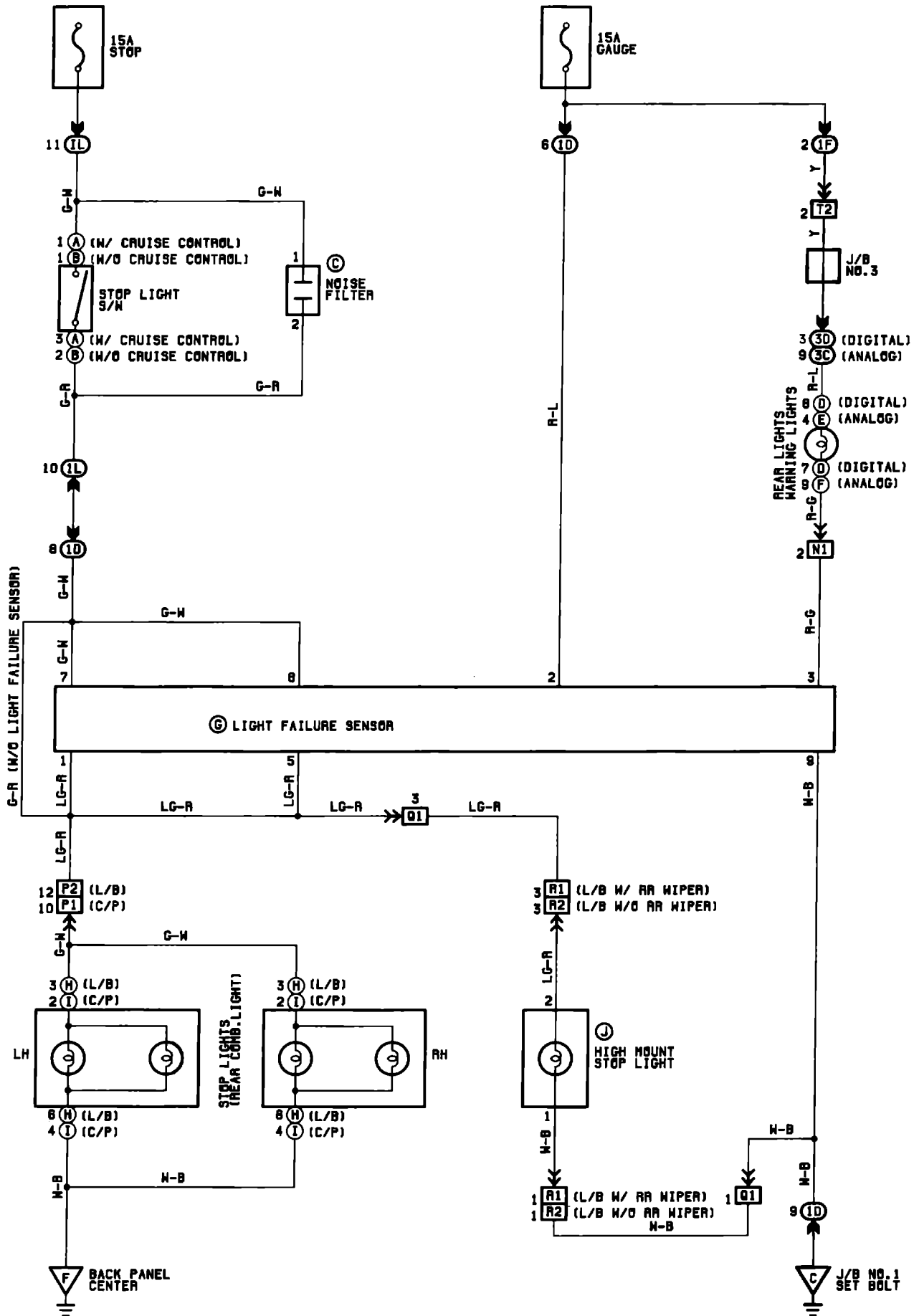

(A)(B) STOP LIGHT S/W
 CLOSED WITH BRAKE PEDAL DEPRESSED
(C) LIGHT FAILURE SENSOR
 1,5,7,8,-9: 12VOLTS WITH STOP LIGHT S/W ON
 2,3,-9: 12VOLTS WITH IGNITION S/W ON

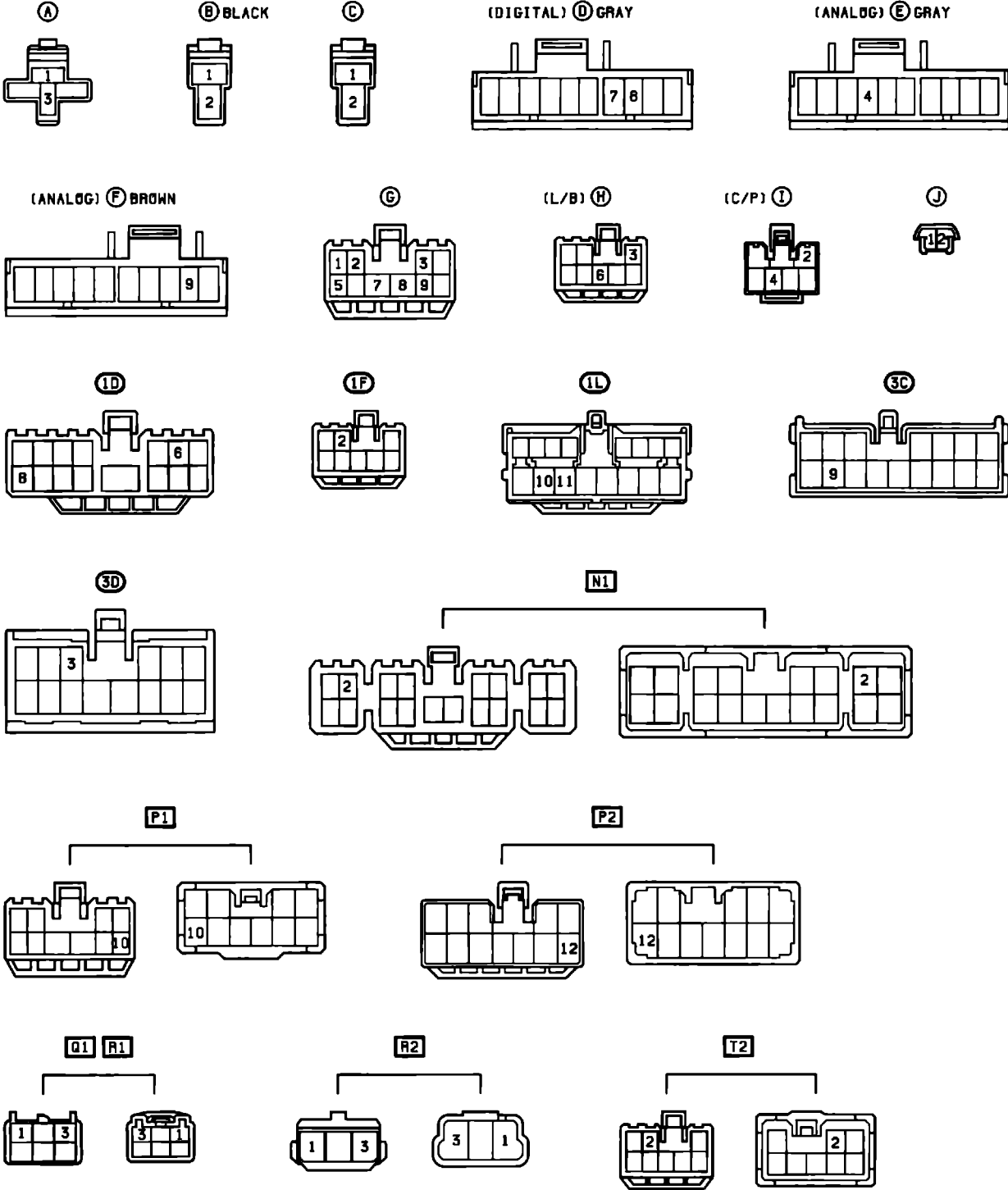

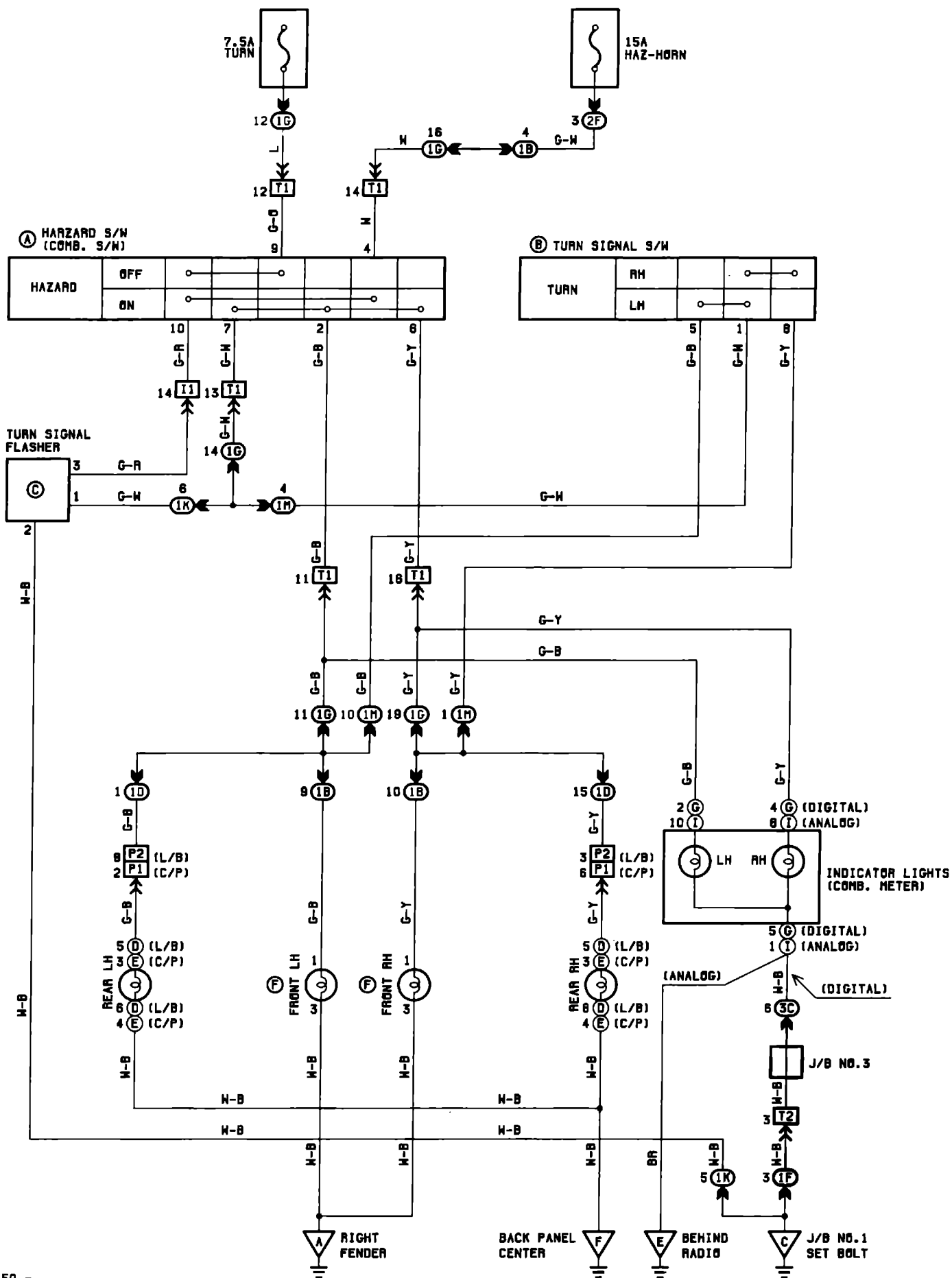

© TURN SIGNAL FLASHER

3-GROUND: 12VOLTS WITH IGNITION S/W ON OR HAZARD S/W ON
 1-GROUND: CHANGES FROM 12 TO 0 VOLTS WITH IGNITION S/W ON
 AND TURN SIGNAL S/W LEFT OR RIGHT, OR WITH HAZARD
 S/W ON

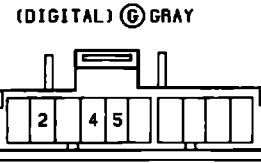
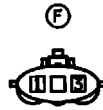
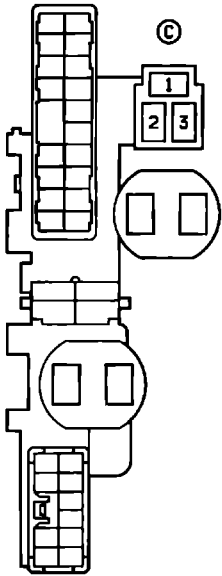
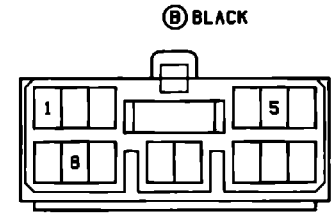
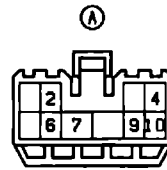

(ANALOG) ① GRAY

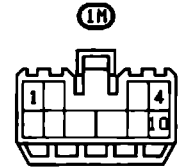
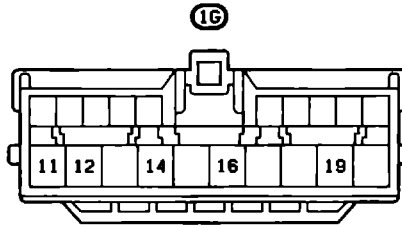
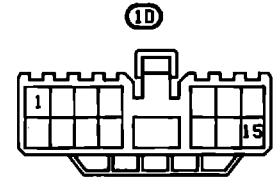
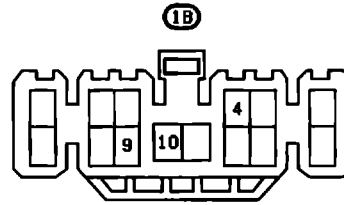
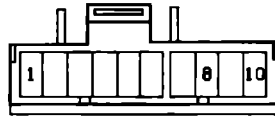

② ORANGE



③

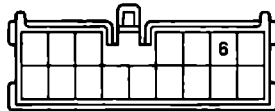

④

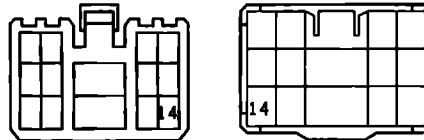

P1

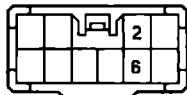
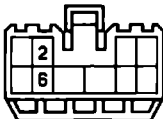

P2

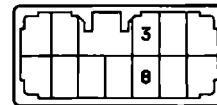
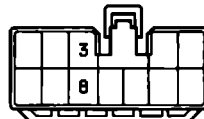

T1

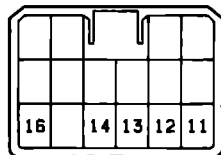
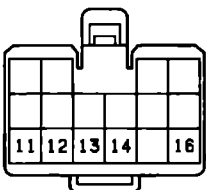

T2

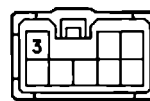

14 FRONT WIPER AND WASHER

(A)
WIPER AND WASHER S/W (W/ WIPER RELAY)
(COMB. S/W)

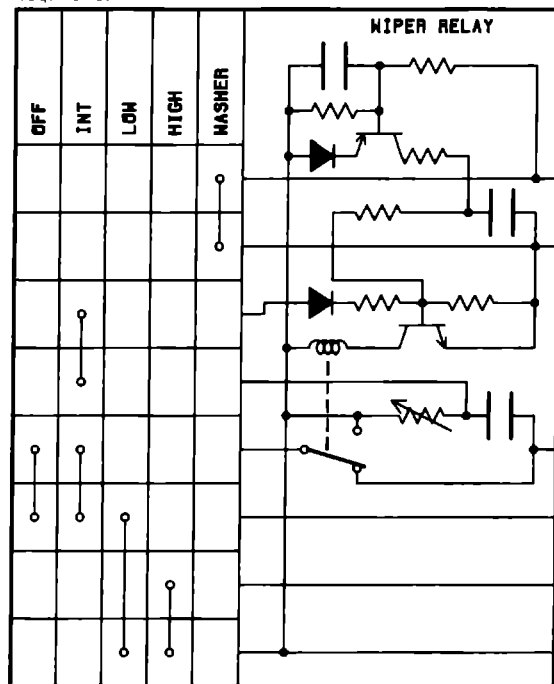

(W/ REAR WIPER) 11 (IN)
(W/O REAR WIPER) 14 (L)

J/B NO. 1
SET BOLT

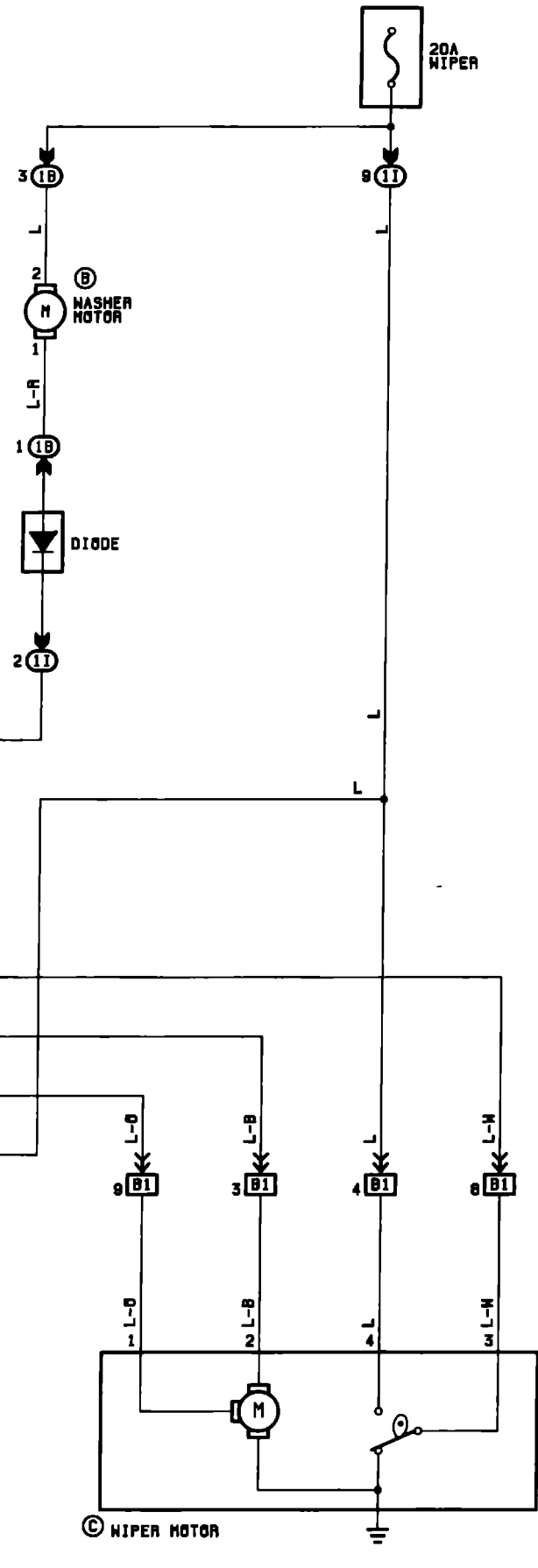

(A) BLACK

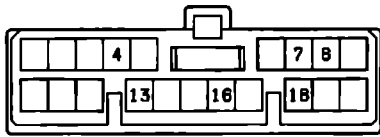

(B)



(C) BLACK



(1B)

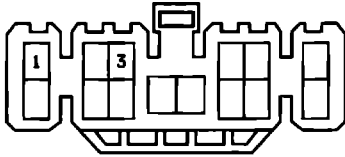

(11)

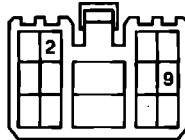

(1L)

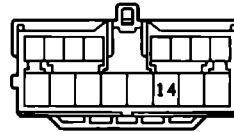

(1N)

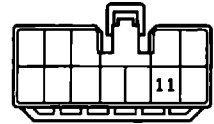

(B1)

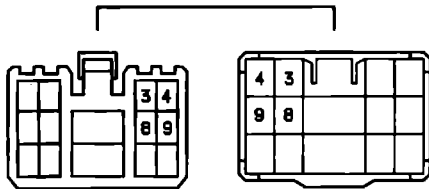



REAR WIPER RELAY
 1-GROUND: 12 VOLTS WITH IGNITION S/W ON
 POINTS CHANGES EVERY 12 SECONDS INTERMITTENTLY WITH
 IGNITION S/W ON AND WIPER S/W AT INT POSITION

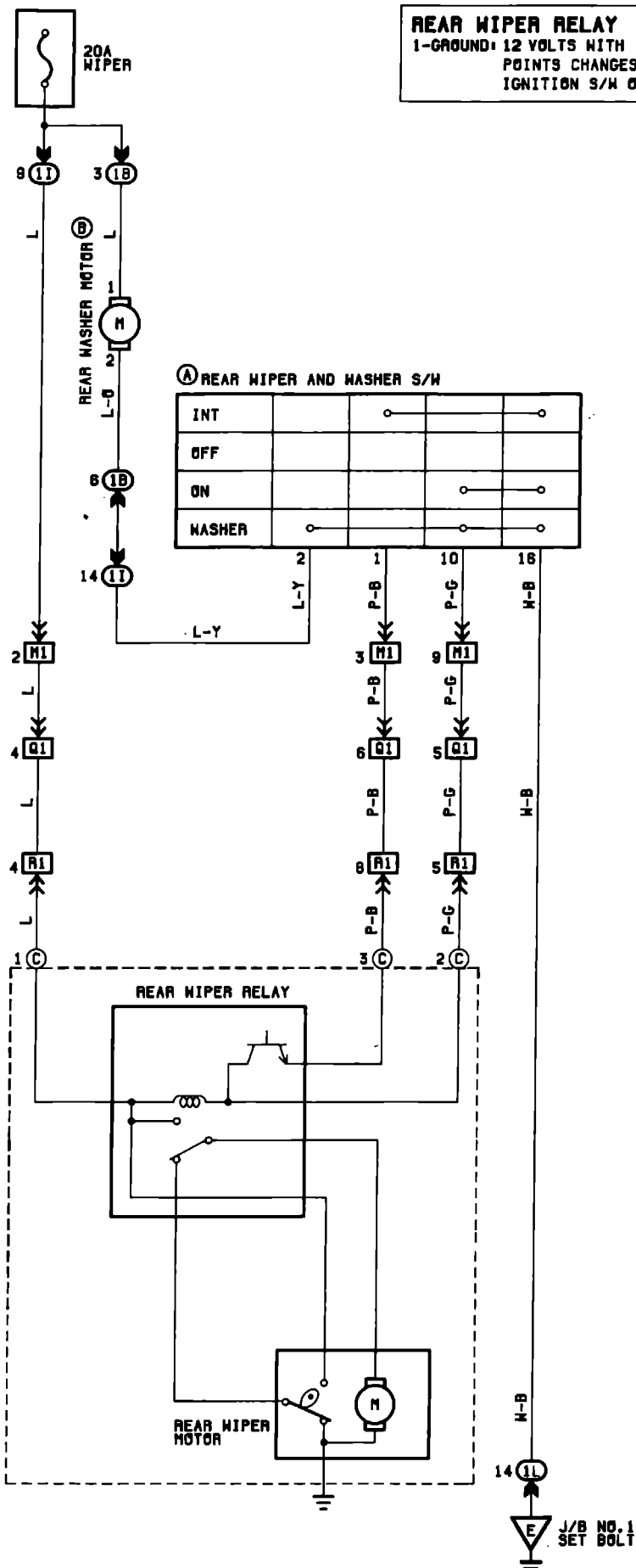

(A) REAR WIPER AND WASHER S/W

INT			
OFF			
ON			
WASHER			

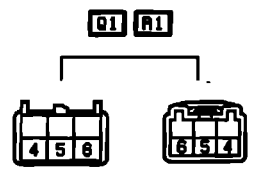
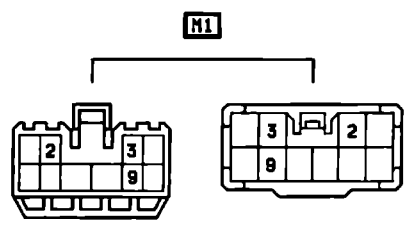
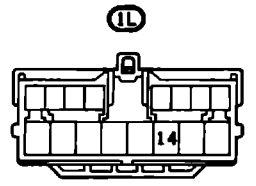
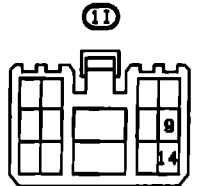
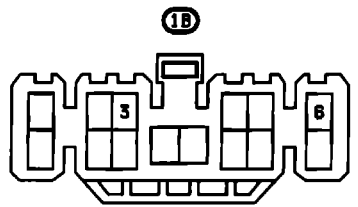
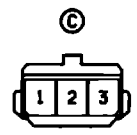
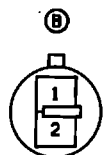
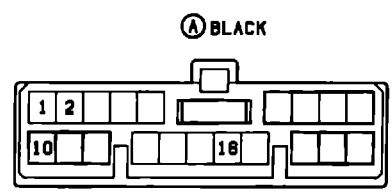

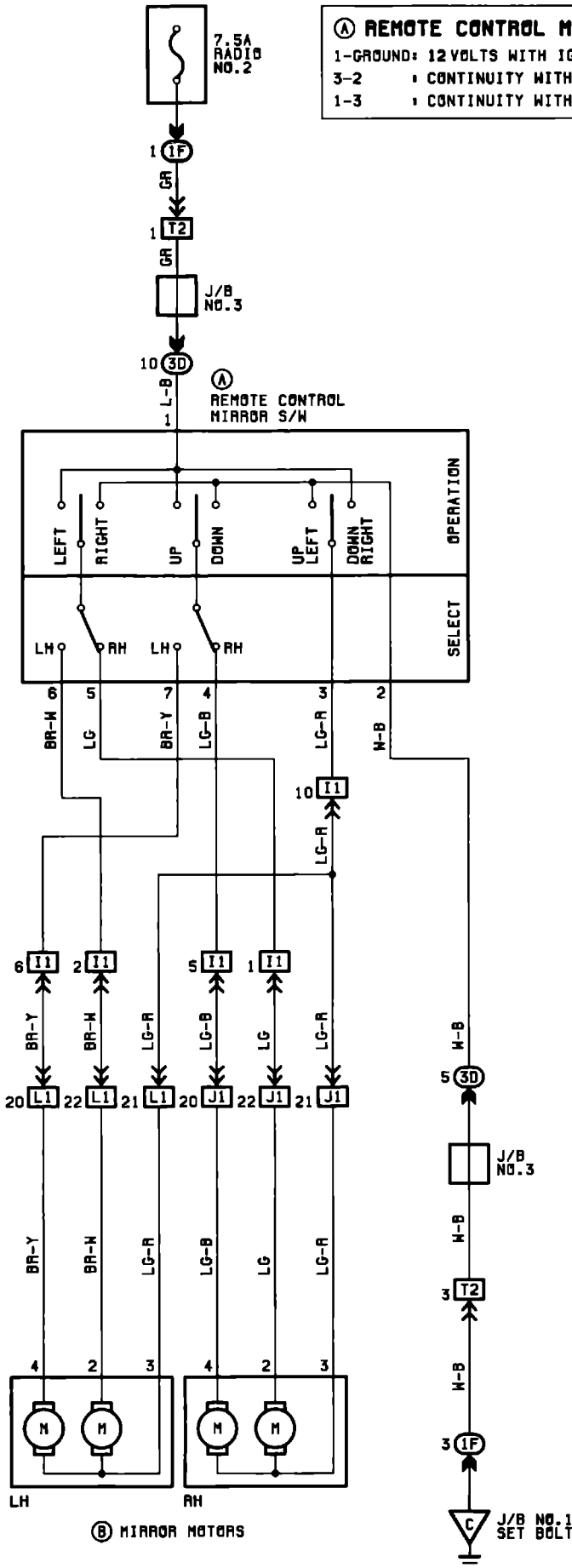

REMOTE CONTROL MIRROR S/W

1-GROUND: 12 VOLTS WITH IGNITION S/W AT ACC OR IG POSITION

3-2 : CONTINUITY WITH OPERATION S/W AT UP OR LEFT POSITION

1-3 : CONTINUITY WITH OPERATION S/W AT DOWN OR RIGHT POSITION

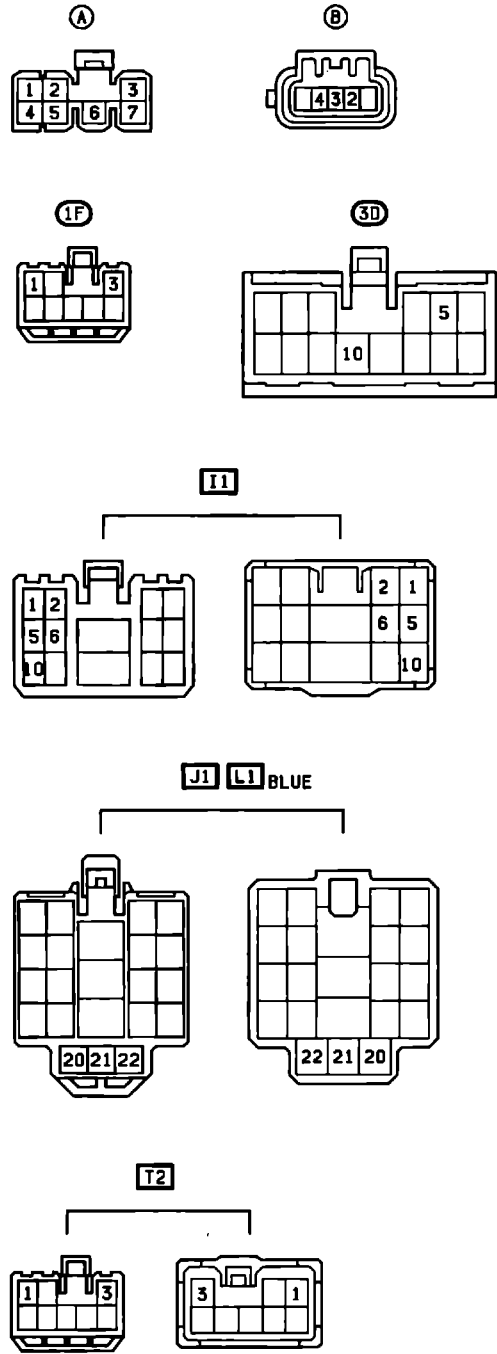

DEFOGGER RELAY
 CLOSED WITH IGNITION S/W ON. DEFOGGER S/W ON
 AND 15 MINUTES THEREAFTER
DEFOGGER S/W (W/ TIMER)
 4-GROUND: 12 VOLTS WITH IGNITION S/W ON
 6-GROUND: ALWAYS CONTINUITY
 5-8 : CONTINUITY WITH DEFOGGER S/W ON AND
 15 MINUTES THEREAFTER

(DIGITAL) (A) GRAY

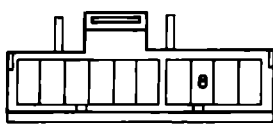

(DIGITAL) (B)

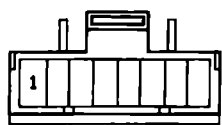

(ANALOG) (C) GRAY

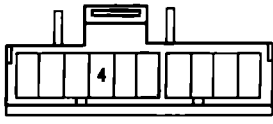

(ANALOG) (D) BROWN

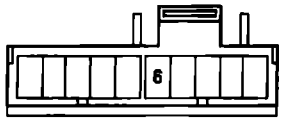

(E)



(F) (G) BLACK



(H)

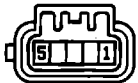

(I D)

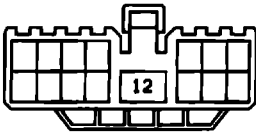

(I F)



(I G)

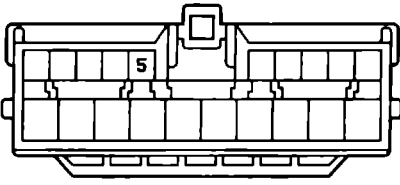

(I L)

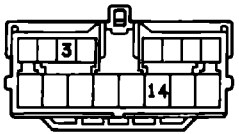

(I N)

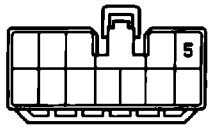

(3 A) ORANGE

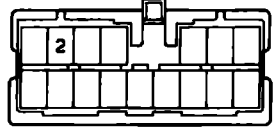

(3 C)

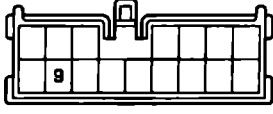

(3 D)

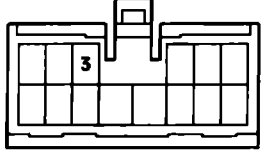

(4 A)

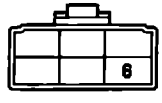

(J1) (L1) BLUE

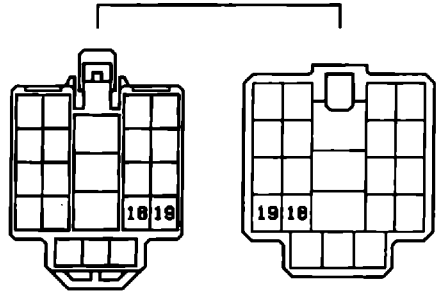

(Q1) (R1)

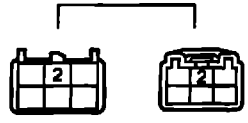

(R2)

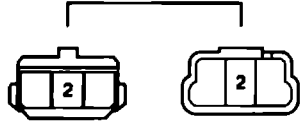

(T1)

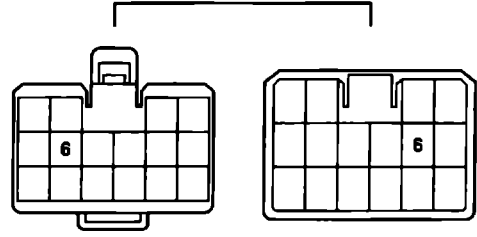

(T2)

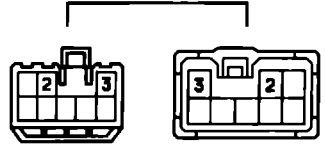

18 DOOR LOCKS

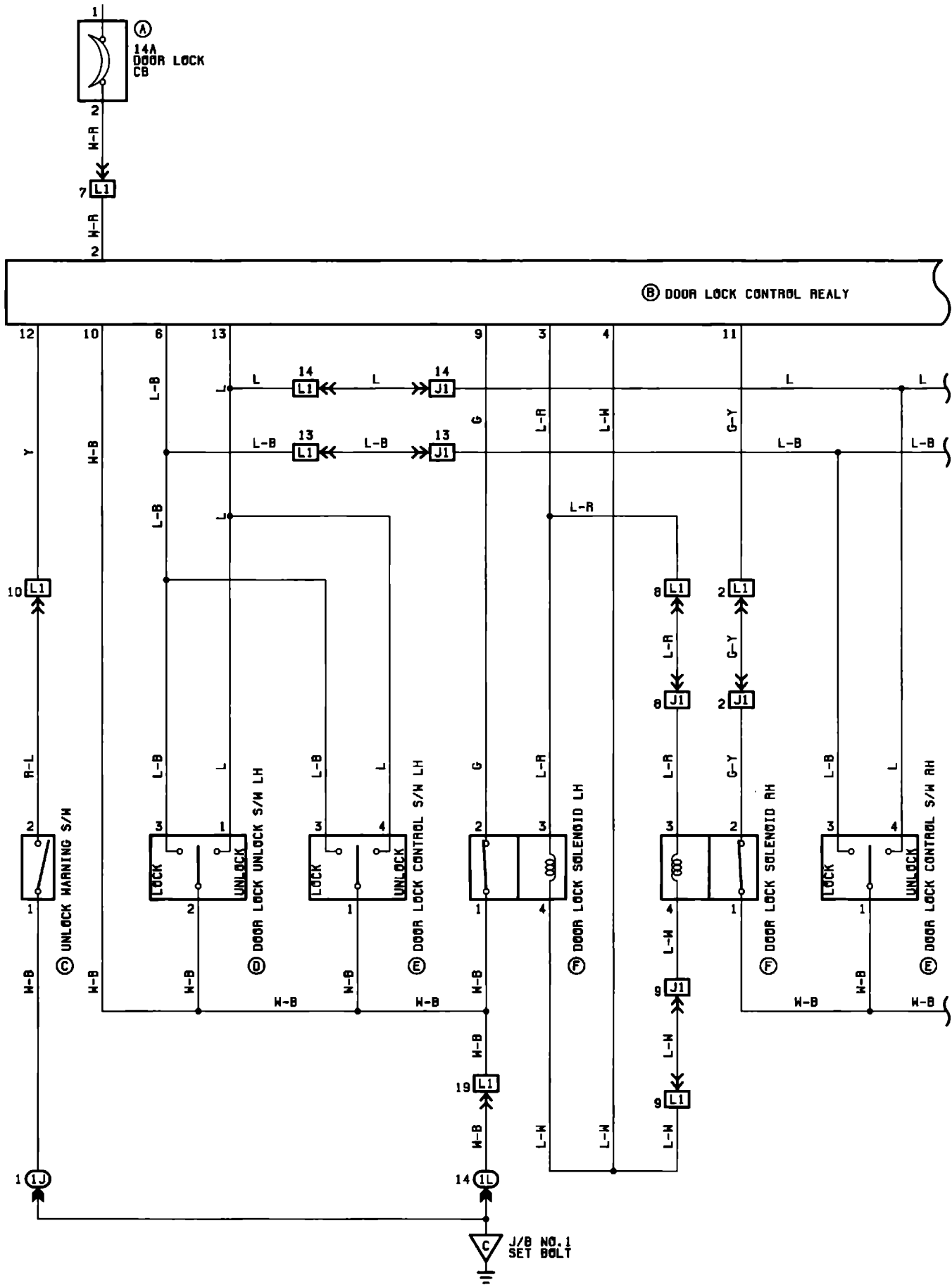

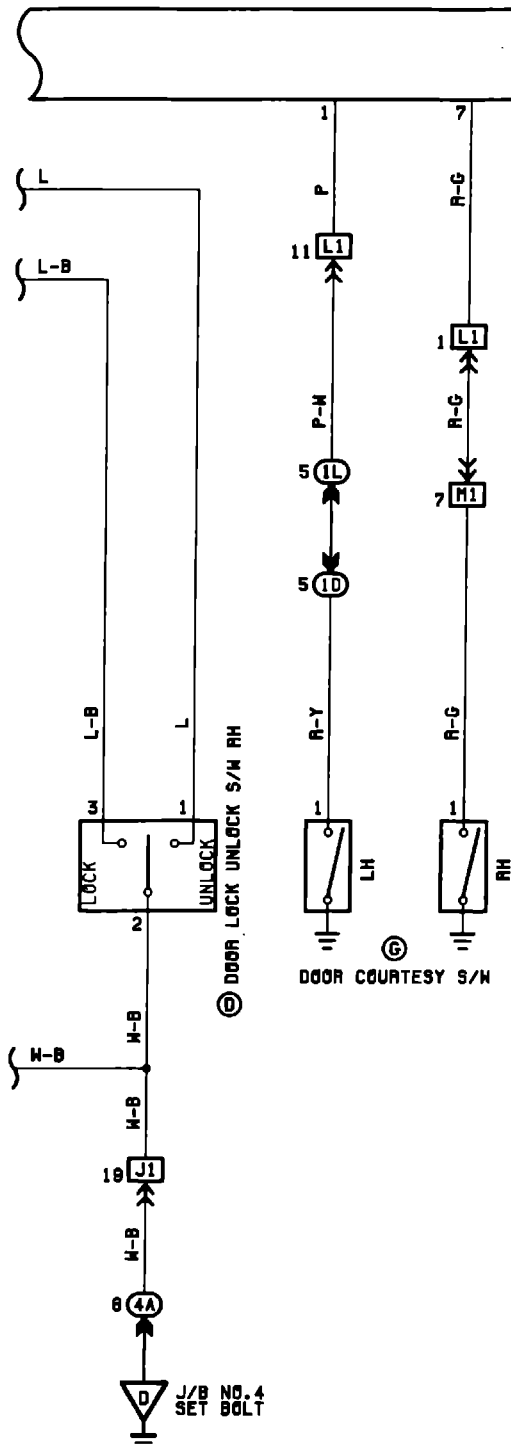

Ⓑ DOOR LOCK CONTROL RELAY

2-GROUND : ALWAYS 12 VOLTS

10-GROUND : ALWAYS CONTINUITY

4-GROUND : 12 VOLTS 0.2 SECONDS WITH FOLLOWING OPERATION
 DOOR LOCK CONTROL S/W LOCKED
 DOOR LOCK KNOB PUSHED DOWN
 DOOR LOCK CYLINDER LOCKED WITH KEY

3-GROUND : 12 VOLTS 0.2 SECONDS WITH FOLLOWING OPERATION
 DOOR LOCK CONTROL S/W UNLOCKED
 DOOR LOCK CONTROL S/W LOCKED WITH IGNITION KEY IN CYLINDER AND DRIVER'S DOOR OPEN (IGNITION KEY REMINDER FUNCTION)
 DOOR LOCK KNOB PUSHED DOWN WITH IGNITION KEY IN CYLINDER AND DRIVER'S DOOR OPEN (IGNITION KEY REMINDER FUNCTION)
 UNLOCKING THE DRIVER'S DOOR CYLINDER WITH KEY

6-GROUND : 12→0 VOLT WITH DOOR LOCK CONTROL S/W LOCKED OR DRIVER'S, ASSISTANT'S DOOR LOCK CYLINDER UNLOCKED WITH KEY

9-GROUND : 12 VOLTS WITH DRIVER'S DOOR LOCK KNOB PUSHED DOWN
 0 VOLT WITH DRIVER'S DOOR LOCK KNOB PULLED UP

11-GROUND : 12 VOLTS WITH ASSISTANT'S DOOR LOCK KNOB PUSHED DOWN
 0 VOLT WITH ASSISTANT'S DOOR LOCK KNOB PULLED UP

12-GROUND : 12 VOLTS WITH THE KEY REMOVED FROM THE IGNITION S/W
 DRIVER'S DOOR CLOSED
 0 VOLT WITH IGNITION KEY CYLINDER AND DRIVER'S DOOR OPEN

13-GROUND : 12→0 VOLT WITH DOOR LOCK CONTROL S/W UNLOCKED OR ASSISTANT'S DOOR LOCK CYLINDER UNLOCKED WITH KEY

Ⓒ UNLOCK WARNING S/W

1-2 : CLOSED WITH IGNITION KEY IN CYLINDER

Ⓓ DOOR LOCK UNLOCK S/W

3-2 : CLOSED WITH DOOR LOCK CYLINDER LOCKED WITH KEY

1-2 : CLOSED WITH DOOR LOCK CYLINDER UNLOCKED WITH KEY

Ⓕ DOOR LOCK SOLENOID

1-2 : CLOSED WITH UNLOCK POSITION

Ⓖ DOOR COURTESY S/W

1-GROUND : CLOSED WITH DOOR OPEN

18 DOOR LOCKS

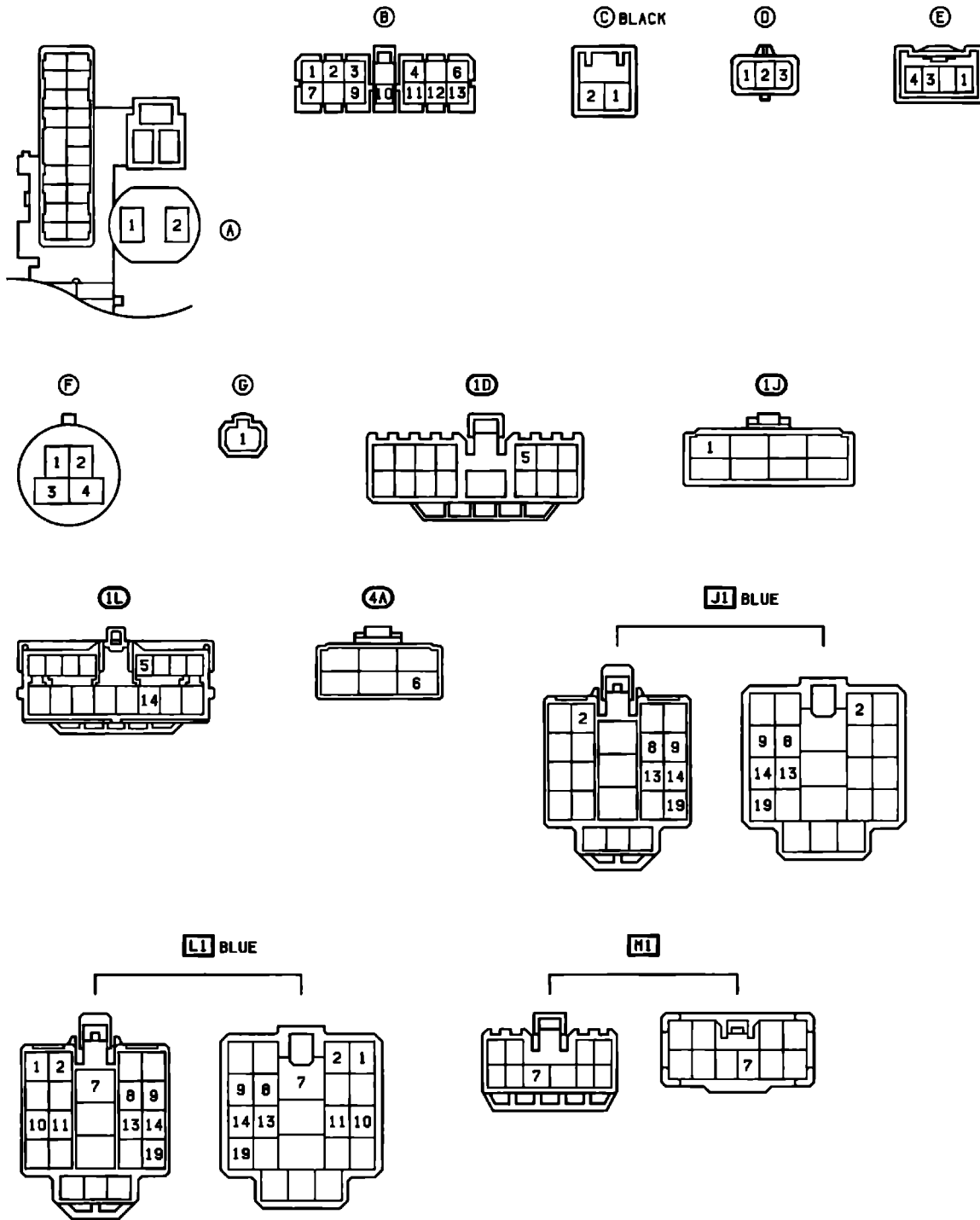

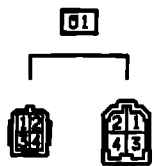
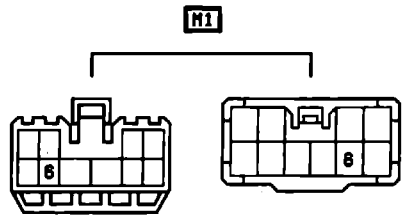
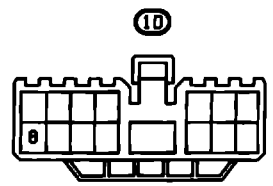
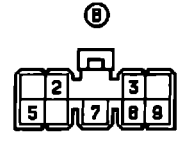
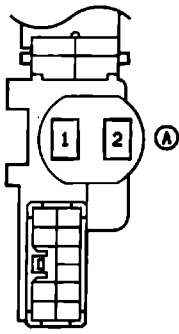
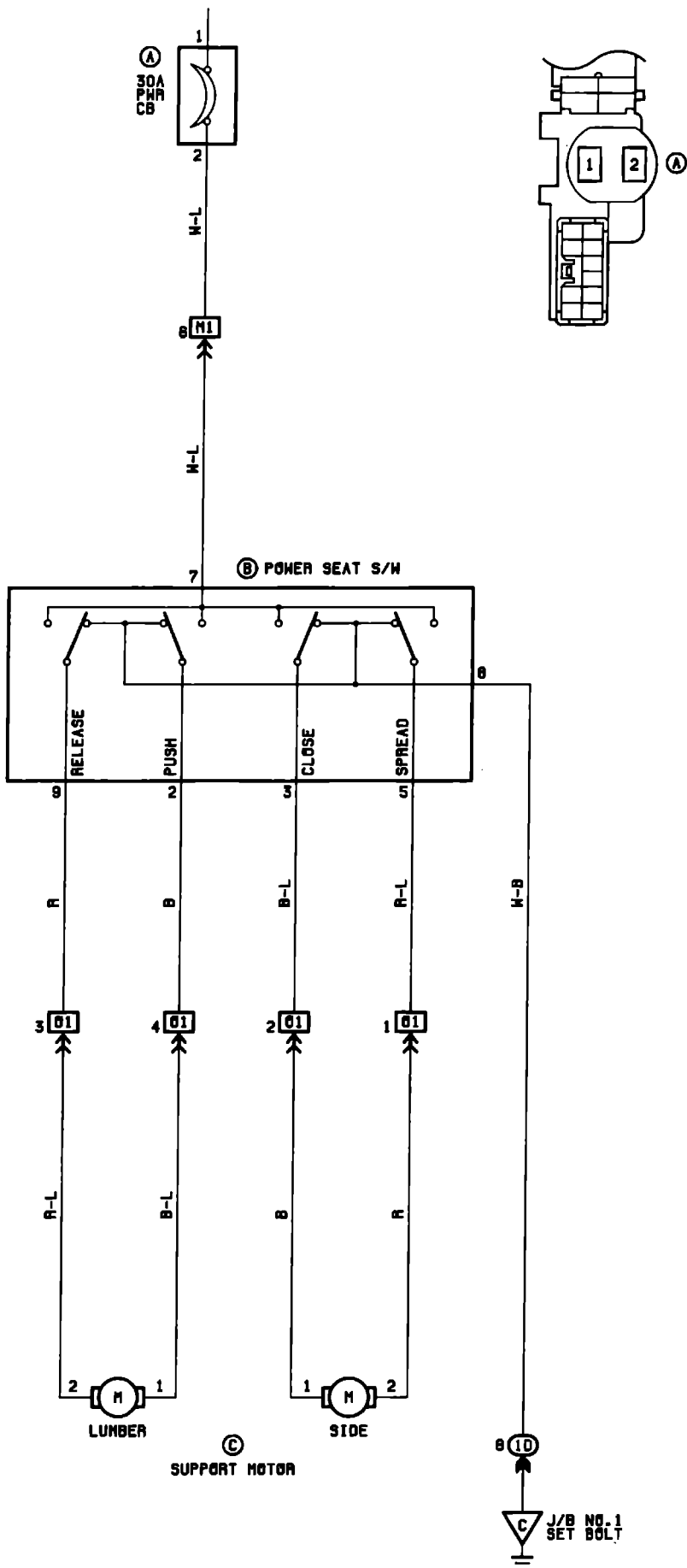

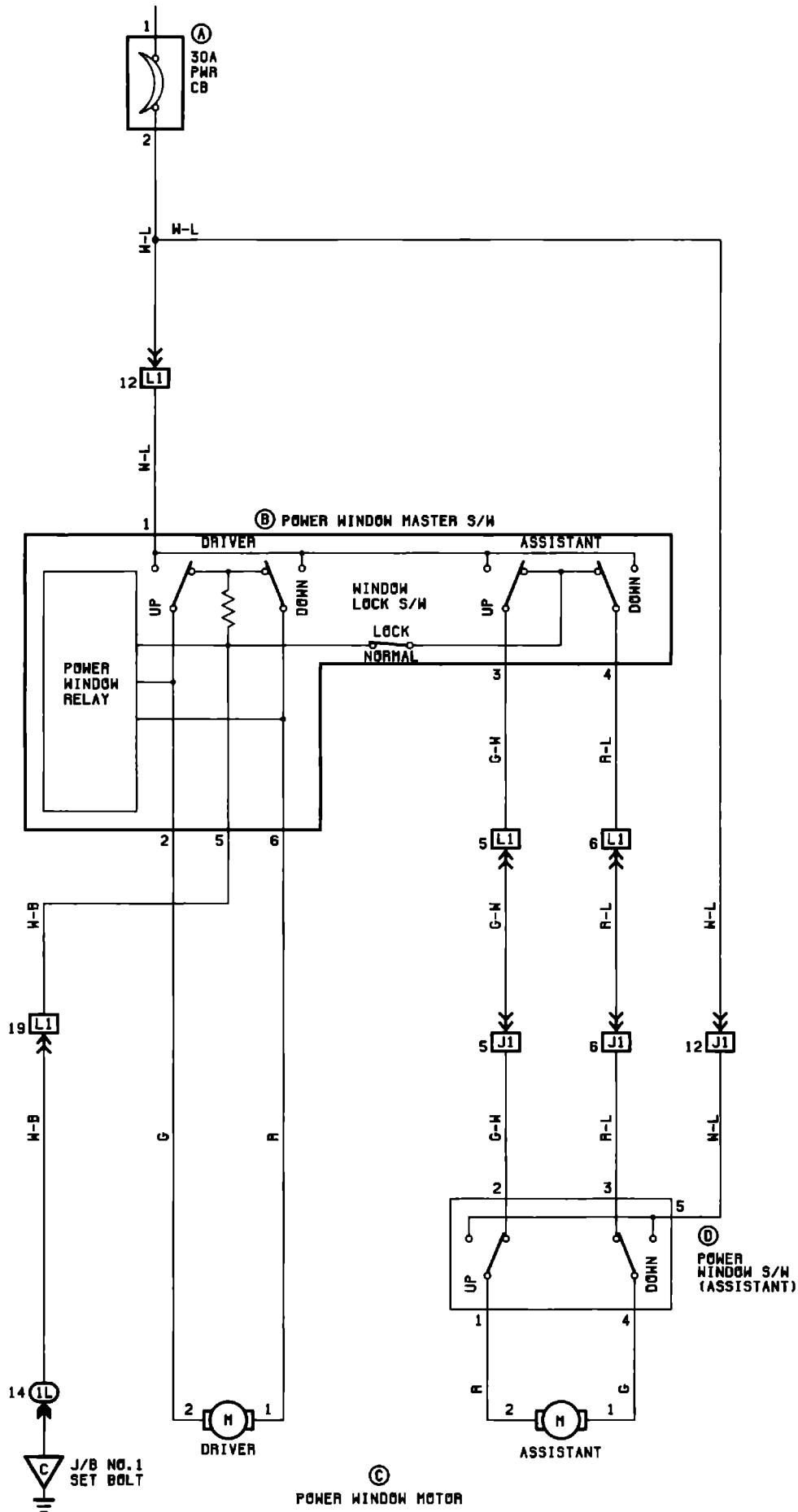

Ⓑ POWER WINDOW MASTER S/W

1-GROUND: 12 VOLTS WITH IGNITION S/W AT IG POSITION

5-GROUND: ALWAYS CONTINUITY

2-GROUND: 12 VOLTS WITH IGNITION S/W ON AND MASTER S/W
(DRIVER'S WINDOW) UP6-GROUND: 12 VOLTS WITH IGNITION S/W ON AND MASTER S/W
(DRIVER'S WINDOW) DOWN OR DOWNAUTO**WINDOW LOCK S/W**

OPEN WITH WINDOW LOCK S/W A/T LOCK POSITION

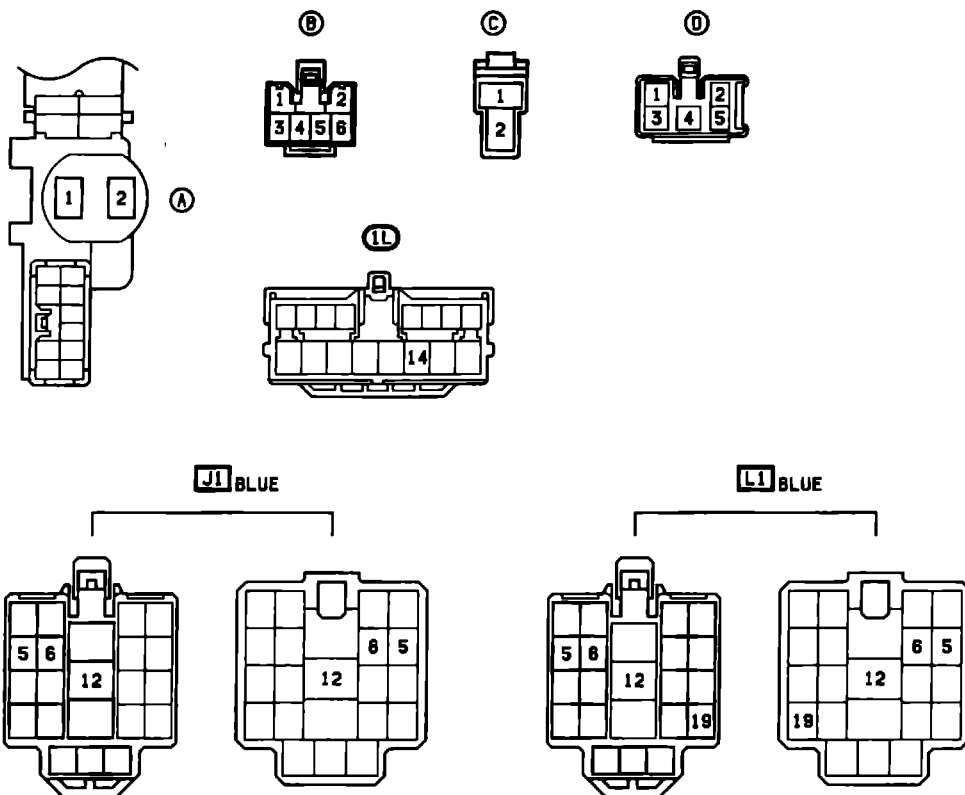

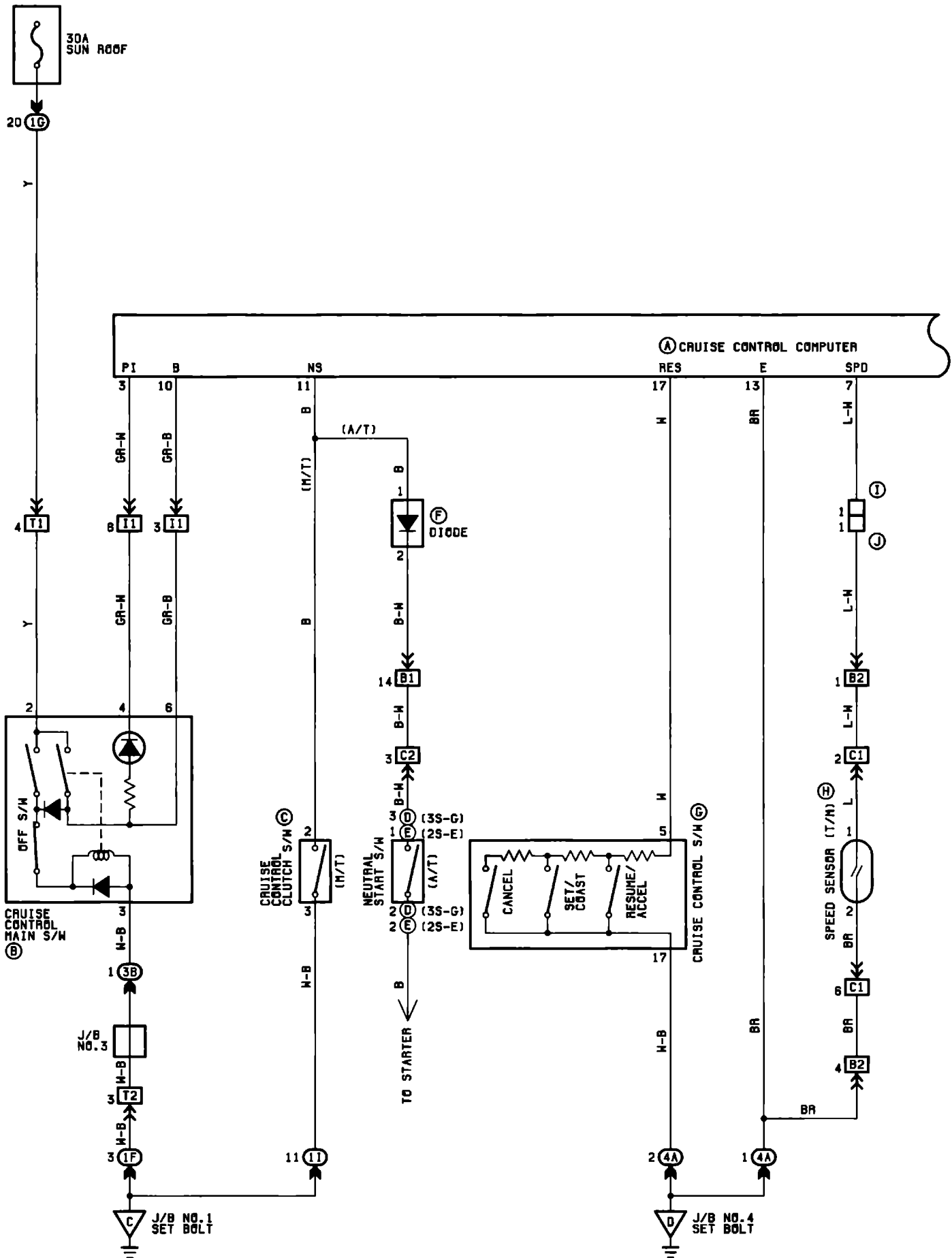

A CRUISE CONTROL COMPUTER
 (DISCONNECT THE COMPUTER CONNECTOR)

2-14	: $\infty \Omega$ WITH BRAKE PEDAL DEPRESSED
	88 Ω WITH BRAKE PEDAL NOT DEPRESSED
4-14	: ALWAYS 30 Ω (ACTUATOR CONTROL VALVE)
7-13	: CONTINUITY EACH 40CM (15.7IN.) (DRIVE VEHICLE SLOWLY)
11-13	: CONTINUITY WITH CLUTCH PEDAL DEPRESSED (M/T) CONTINUITY WITH SHIFT LEVER IN N OR P RANGE (A/T) (ONE OF THE CANCEL S/W)
12-13	: CONTINUITY WITH PKB LEVER PULL UP (ONE OF THE CANCEL S/W)
13-GROUND:	ALWAYS CONTINUITY
17-13	: 88 Ω WITH RESUME/ACCEL S/W ON
	188 Ω WITH SET/COAST S/W ON
	418 Ω WITH CANCEL S/W ON
3-13	: APPROX. 12VOLTS WITH IGNITION S/W ON, MAIN S/W ON
6-13	: 0VOLT WITH IGNITION S/W ON, COOLANT TEMP. BELOW 35°C (95°F)
	12VOLTS WITH IGNITION S/W ON, COOLANT TEMP. MORE THAN 55°C (131°F) (2S-E)
	5 (12) VOLTS WITH IGNITION S/W ON, COOLANT TEMP. MORE THAN 70°C (158°F) (3S-G)
	() : AISIN ECT COMPUTER
10-13	: 12VOLTS WITH IGNITION S/W ON, MAIN S/W ON
15-13	: 12VOLTS WITH BRAKE PEDAL DEPRESSED (ONE OF THE CANCEL S/W)
16-13	: ALWAYS 12VOLTS

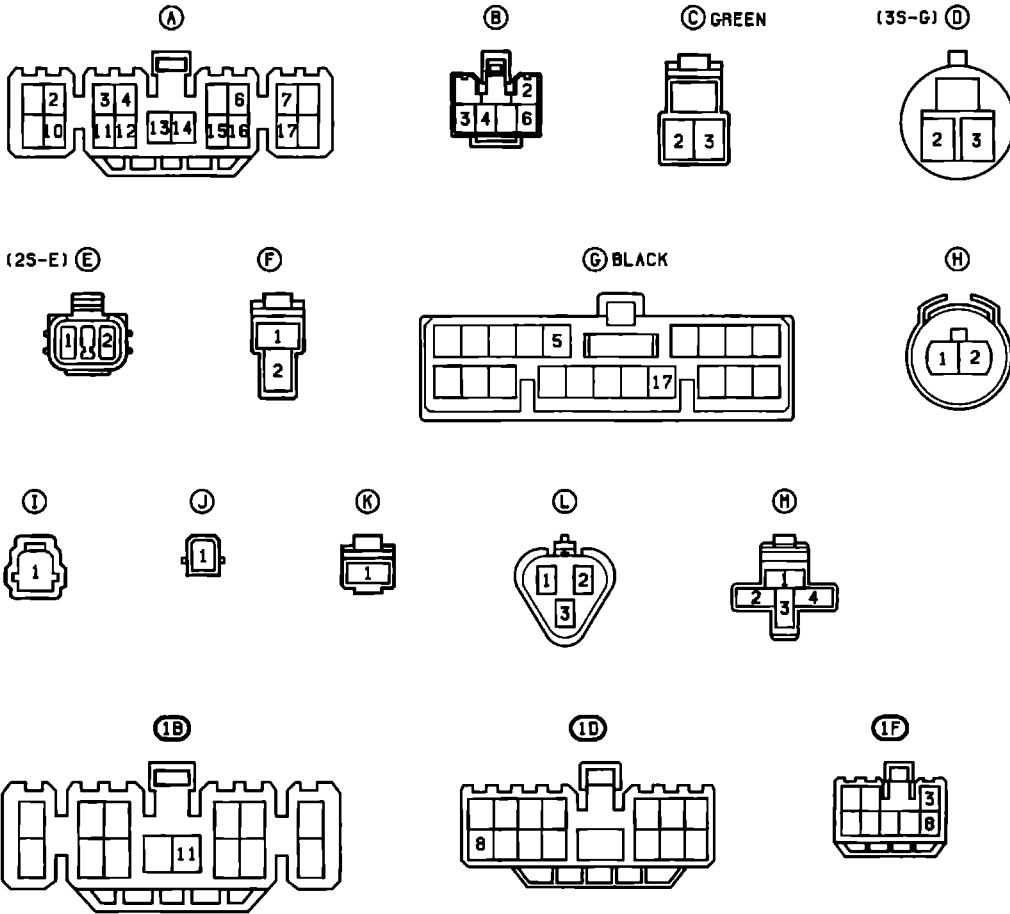

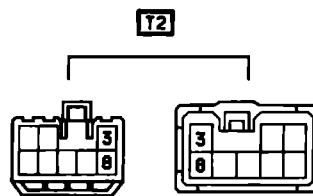
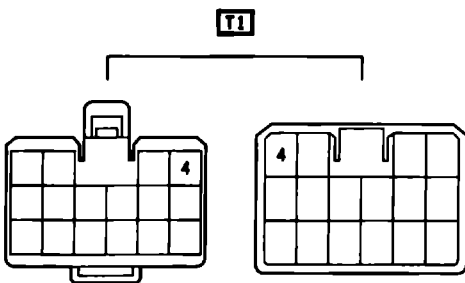
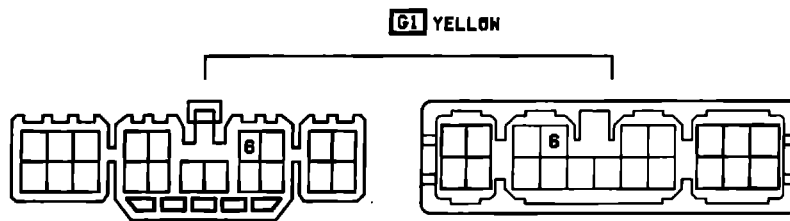
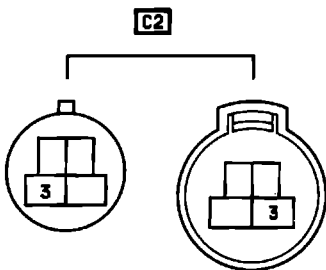
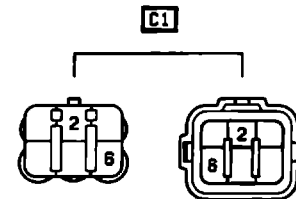
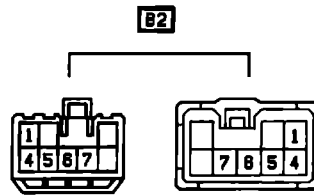
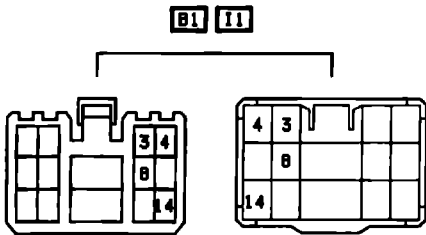
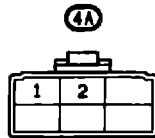
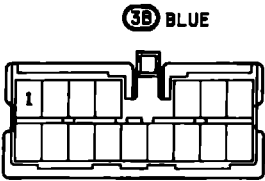
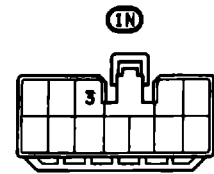
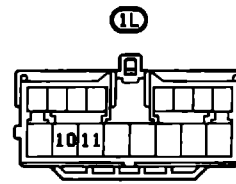
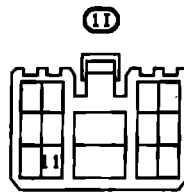
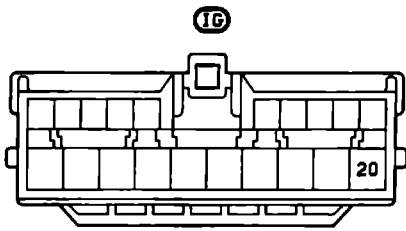

22 ECT PRND2L ECT AND A/T INDICATOR

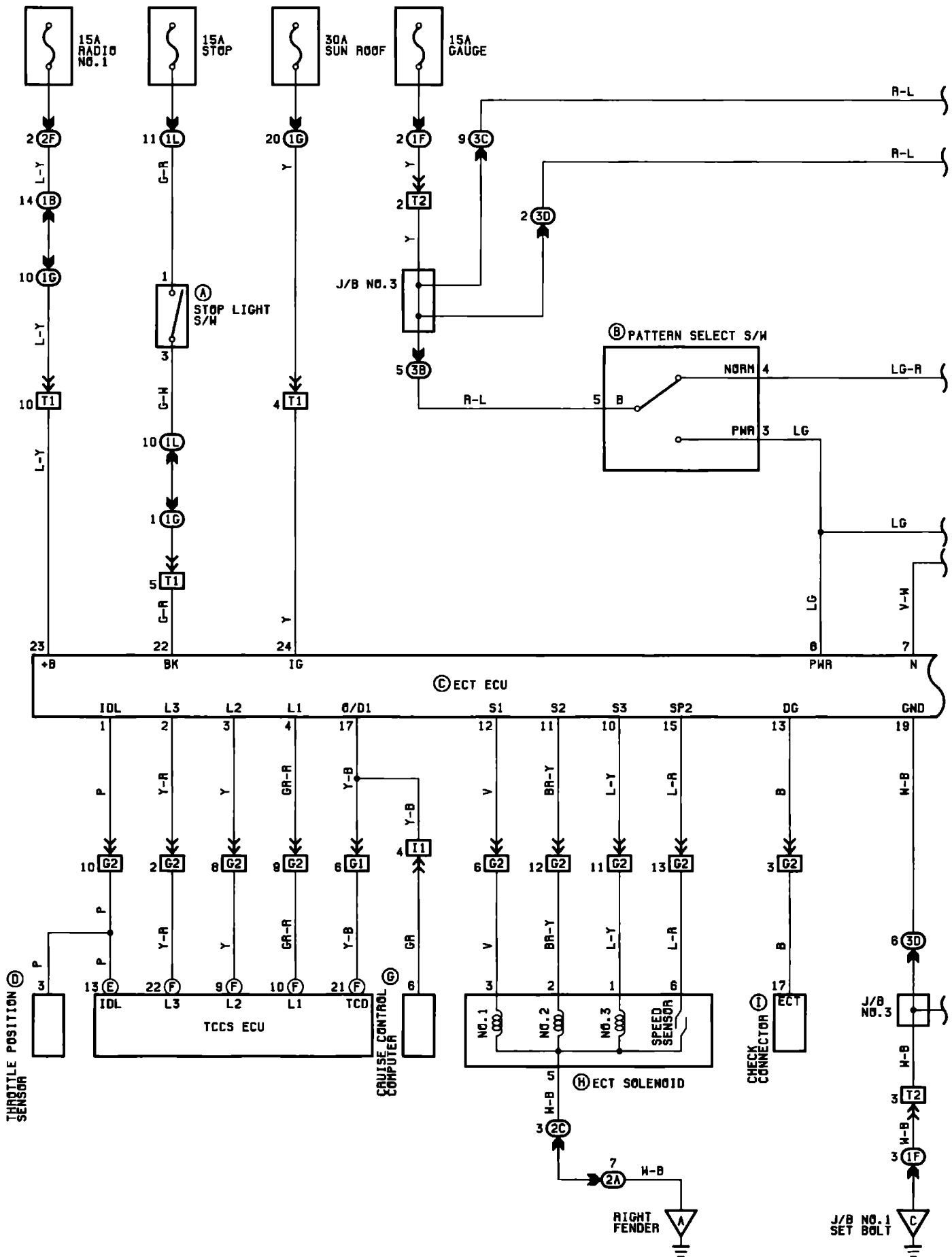

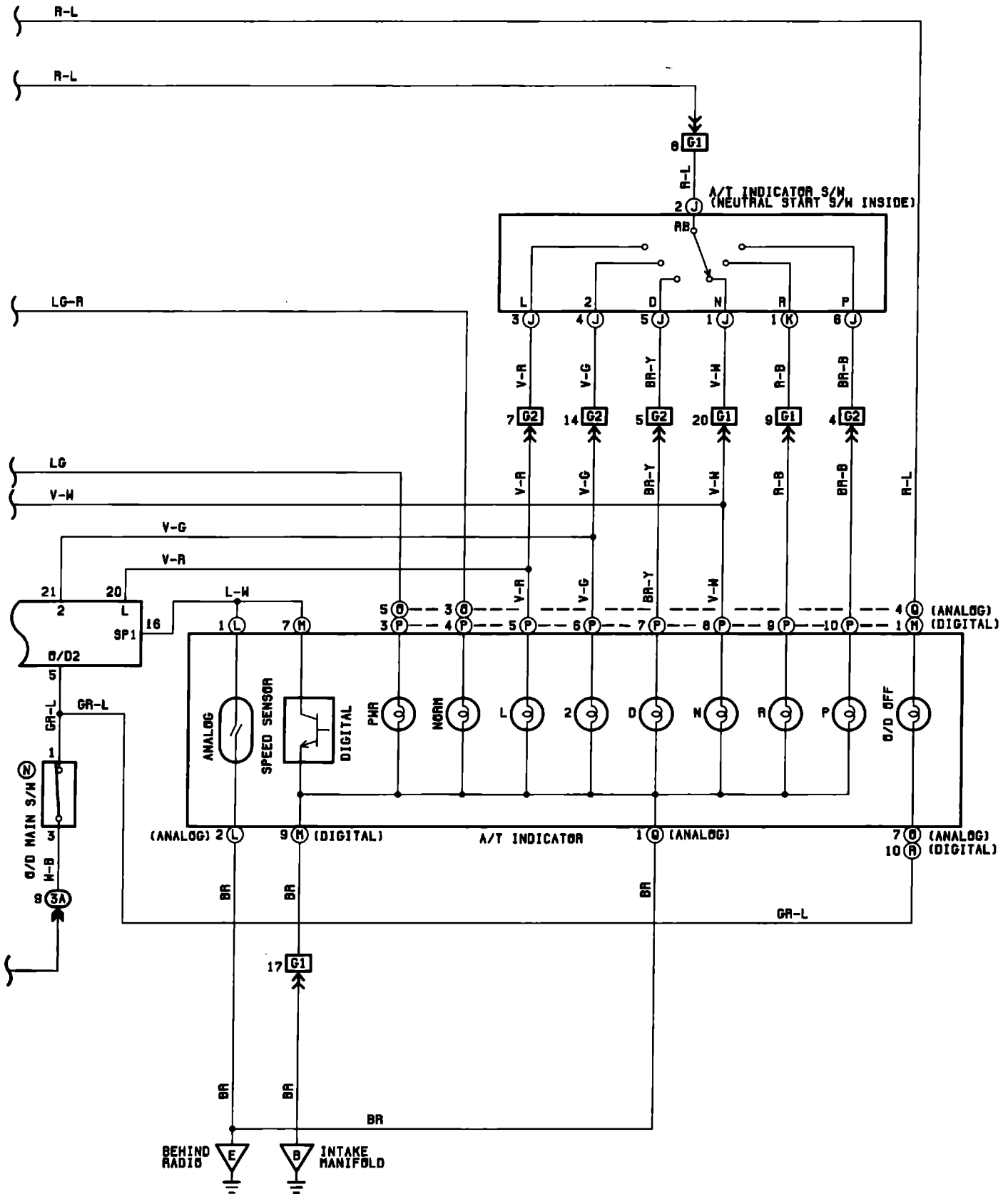

Ⓒ ECT ECU (ELECTRONIC CONTROLLED UNIT) (IGNITION S/W ON)

- 19-GROUND: ALWAYS CONTINUITY
 2-GROUND: 5→0→5→0→5 VOLTS
 3-GROUND: 5→0→5 VOLTS
 4-GROUND: 5→0 VOLT
- (SLOWLY DEPRESS THE ACCEL PEDAL)
- 1-19 : 0VOLT WITH THROTTLE VALVE FULLY CLOSED
 4VOLTS WITH THROTTLE VALVE OPENING ABOVE 1.5°
 16-19 : 12VOLTS OR 0VOLT WITH STANDING STILL
 8VOLTS WITH ENGINE RUNNING, VEHICLE MOVING
 22-19 : 12VOLTS WITH BRAKE PEDAL DEPRESSED
 0VOLT WITH BRAKE PEDAL NOT DEPRESSED
 21-19 : 9 TO 16VOLTS WITH SHIFT LEVER AT 2 POSITION
 0 TO 2VOLTS WITH SHIFT LEVER AT EXCEPT 2 POSITION
 20-19 : 9 TO 16VOLTS WITH SHIFT LEVER AT L POSITION
 0 TO 2VOLTS WITH SHIFT LEVER AT EXCEPT L POSITION
 12-19 : 12VOLTS
 10, 11-19 : 0VOLT
 5-19 : 12VOLTS WITH O/D MAIN S/W ON
 0VOLT WITH O/D MAIN S/W OFF
 24-19 : 12VOLTS WITH STANDING STILL
 15-19 : 5(12) VOLTS WITH STANDING STILL
 4(10) VOLTS WITH ENGINE RUNNING
 8-19 : 12VOLTS WITH PATTERN SELECT S/W AT PMR POSITION
 1VOLT WITH PATTERN SELECT S/W AT NORM POSITION
 23-19 : 12VOLTS
 17-GROUND: 0VOLT WITH COOLANT TEMP. 35-80°C (95-140°F)
 5(12) VOLTS WITH COOLANT TEMP. MORE THAN 70°C (158°F)
 (1): AISIN COMPUTER

Ⓜ ECT SOLENOID

- 1, 2, 3-GROUND: EACH 11-15 Ω

Ⓝ A/T INDICATOR S/W

- 5-GROUND: 12 VOLTS WITH IGNITION S/W ON

A/T INDICATOR

- Ⓛ 2, Ⓜ 9, Ⓞ 1-GROUND: ALWAYS CONTINUITY

Ⓝ O/D MAIN S/W

- 1-3 : CLOSED WITH O/D MAIN S/W OFF
 OPEN WITH O/D MAIN S/W ON

SPEED SENSOR (COMB. METER)

- Ⓛ 1- Ⓛ 2 (ANALOG METER)
 Ⓜ 7- Ⓜ 9 (DIGITAL METER)

REVOLVE METER SHAFT AND CHECK THAT METER NEEDLE REPEATEDLY DEFLECTS FROM 0 Ω TO ∞ Ω

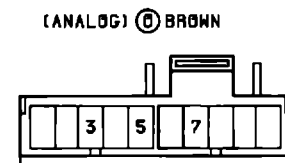
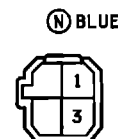
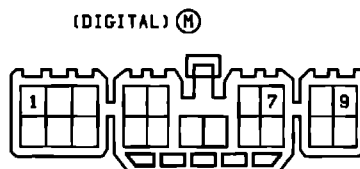
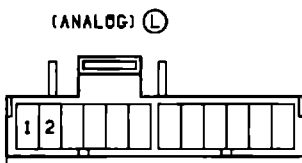
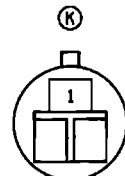
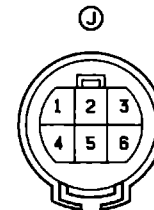
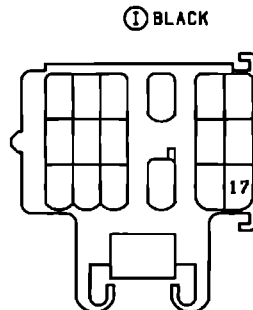
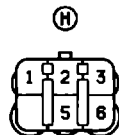
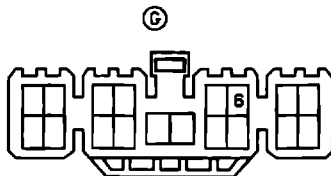
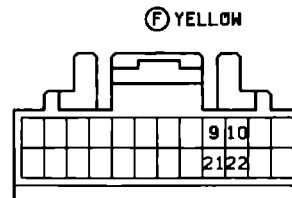
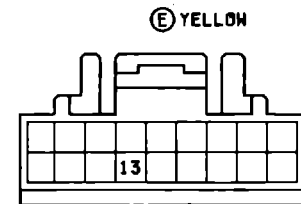
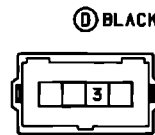
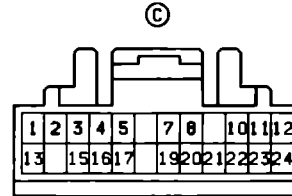
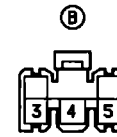

(DIGITAL) P

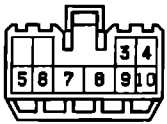

(ANALOG) Q GRAY

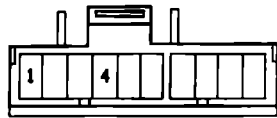

(DIGITAL) R GRAY

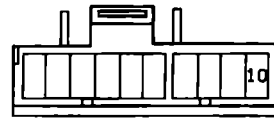

1B

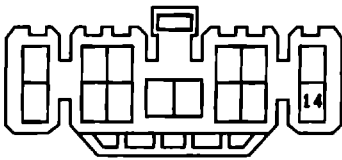

1F

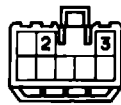

1G

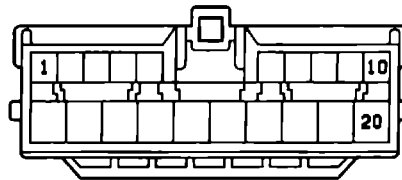

1L

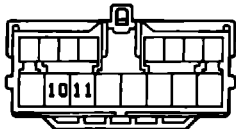

2A



2C



2F ORANGE



3A ORANGE

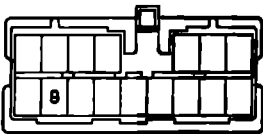

3B BLUE

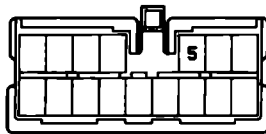

3C

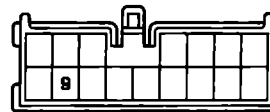

3D

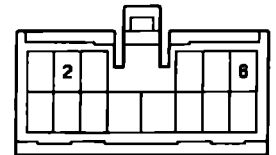

G1 YELLOW

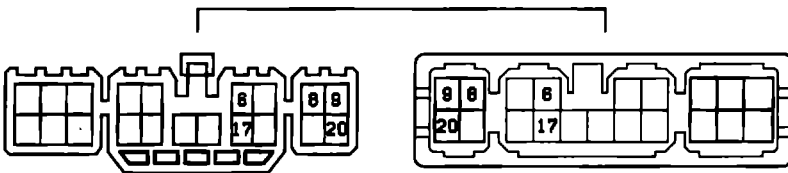

G2

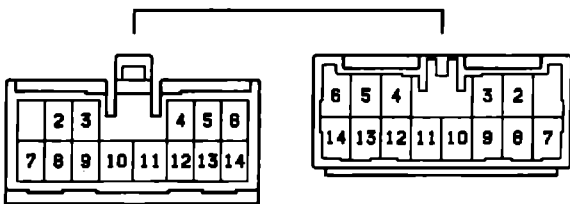

I1

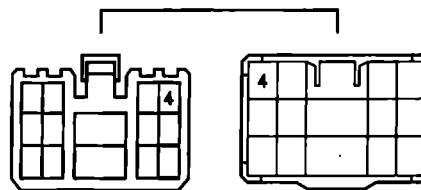

T1

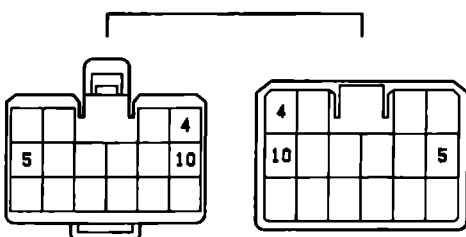

T2

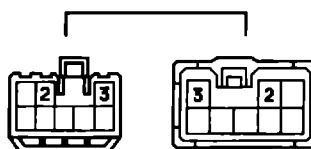

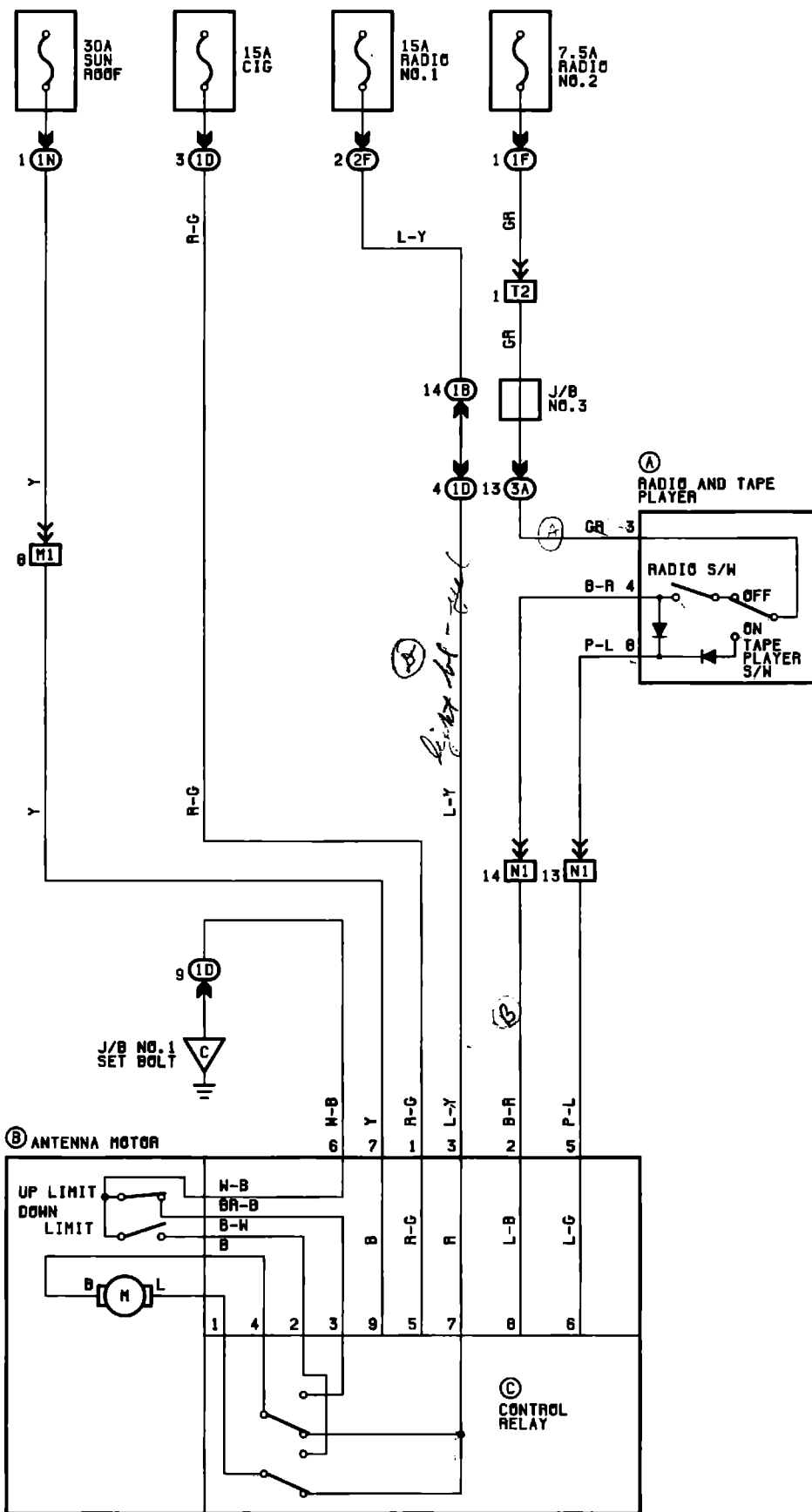

© CONTROL RELAY

- 3-GROUND: CONTINUITY (UPPER LIMIT S/W ON)
UNLESS ANTENNA AT UP STOP
- 2-GROUND: CONTINUITY (DOWN LIMIT S/W ON)
UNLESS ANTENNA AT DOWN STOP
- 4-3 : CLOSED WITH IGNITION S/W AT ACC OR
IG POSITION AND RADIO S/W ON AND
PLAYER S/W OFF UNTIL ANTENNA AT
UPPERMOST POSITION
- 1-2 : CLOSED WITH IGNITION S/W AT ACC OR
IG POSITION AND RADIO S/W OFF AND
PLAYER S/W OFF UNTIL ANTENNA AT
LOWERMOST POSITION
- 1-2 : CLOSED WITH IGNITION S/W OFF UNTIL
ANTENNA AT LOWERMOST POSITION

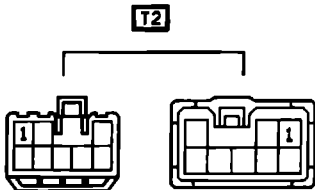
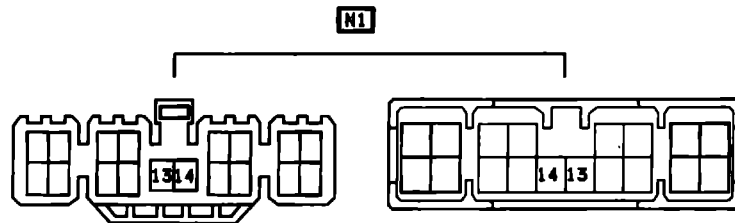
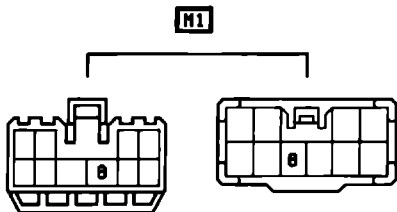
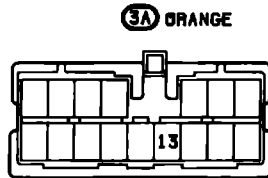
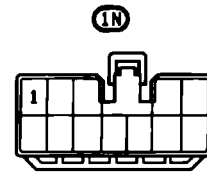
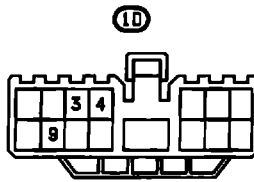
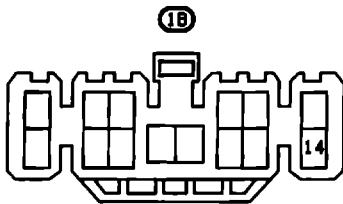
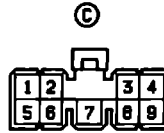
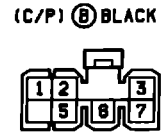
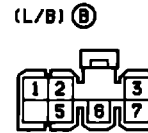
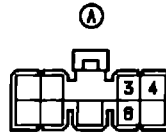

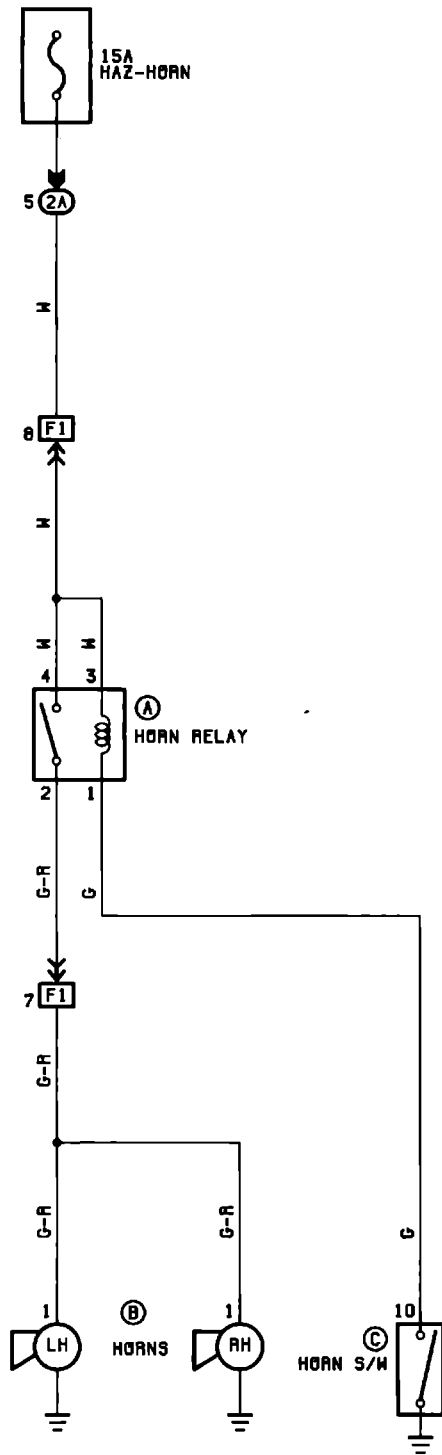

(A) HORN RELAY
2-4: CLOSED WITH HORN S/W ON

(B) BLACK

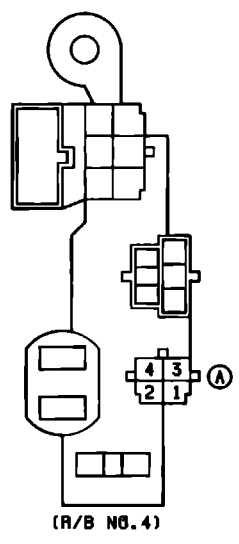

(C) BLACK

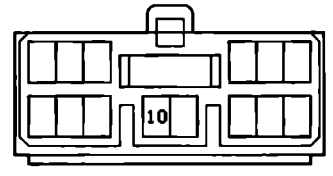

(2A)

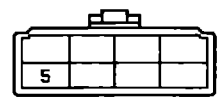

(F1)

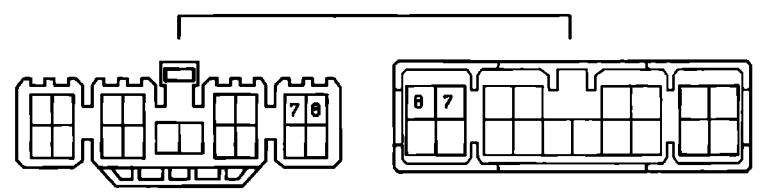

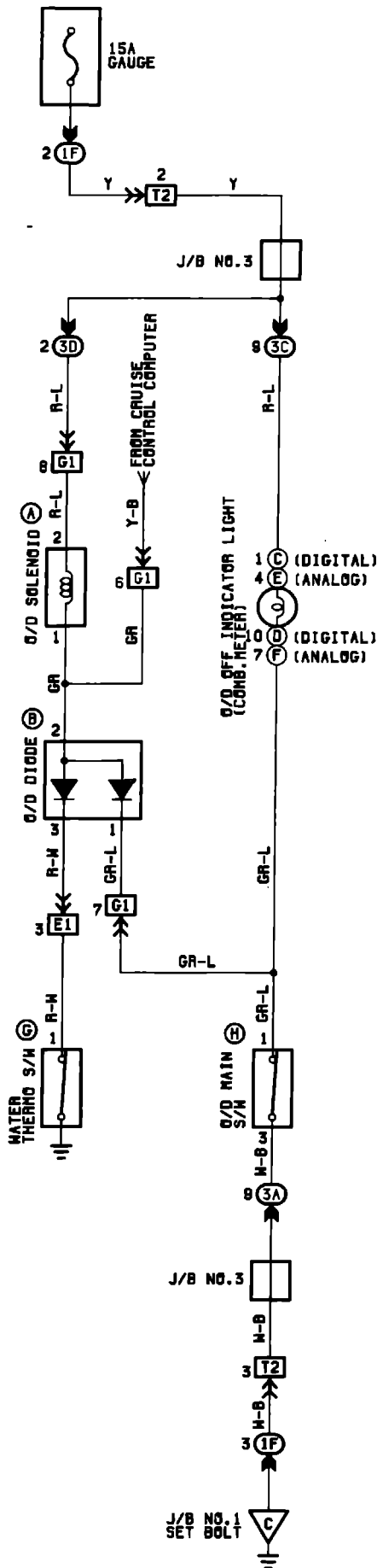

- (A) O/D SOLENOID**
1-GROUND; APPROX. 13Ω
- (C) WATER THERMO S/W**
1-GROUND; CLOSED BELOW 43°C (109°F)
OPEN ABOVE 55°C (131°F)
- (H) O/D MAIN S/W**
1-3: CLOSED WITH O/D S/W AT OFF POSITION
OPEN WITH O/D S/W AT ON POSITION

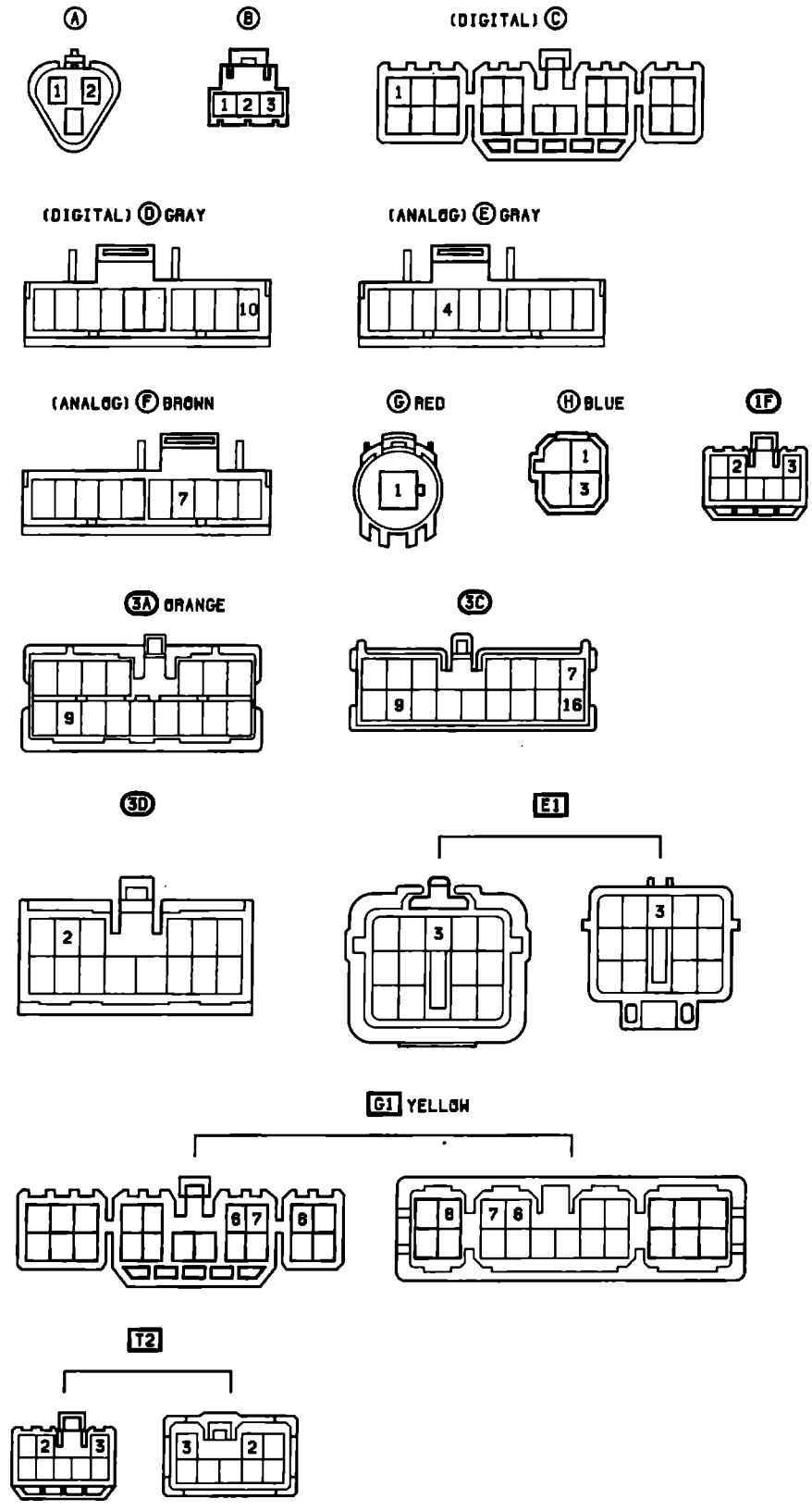

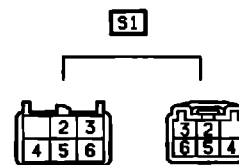
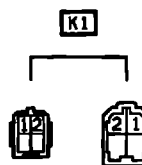
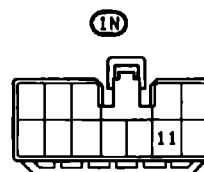
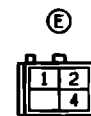
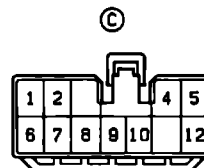
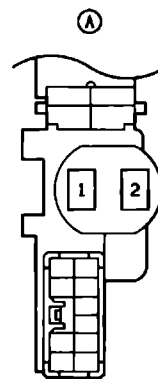
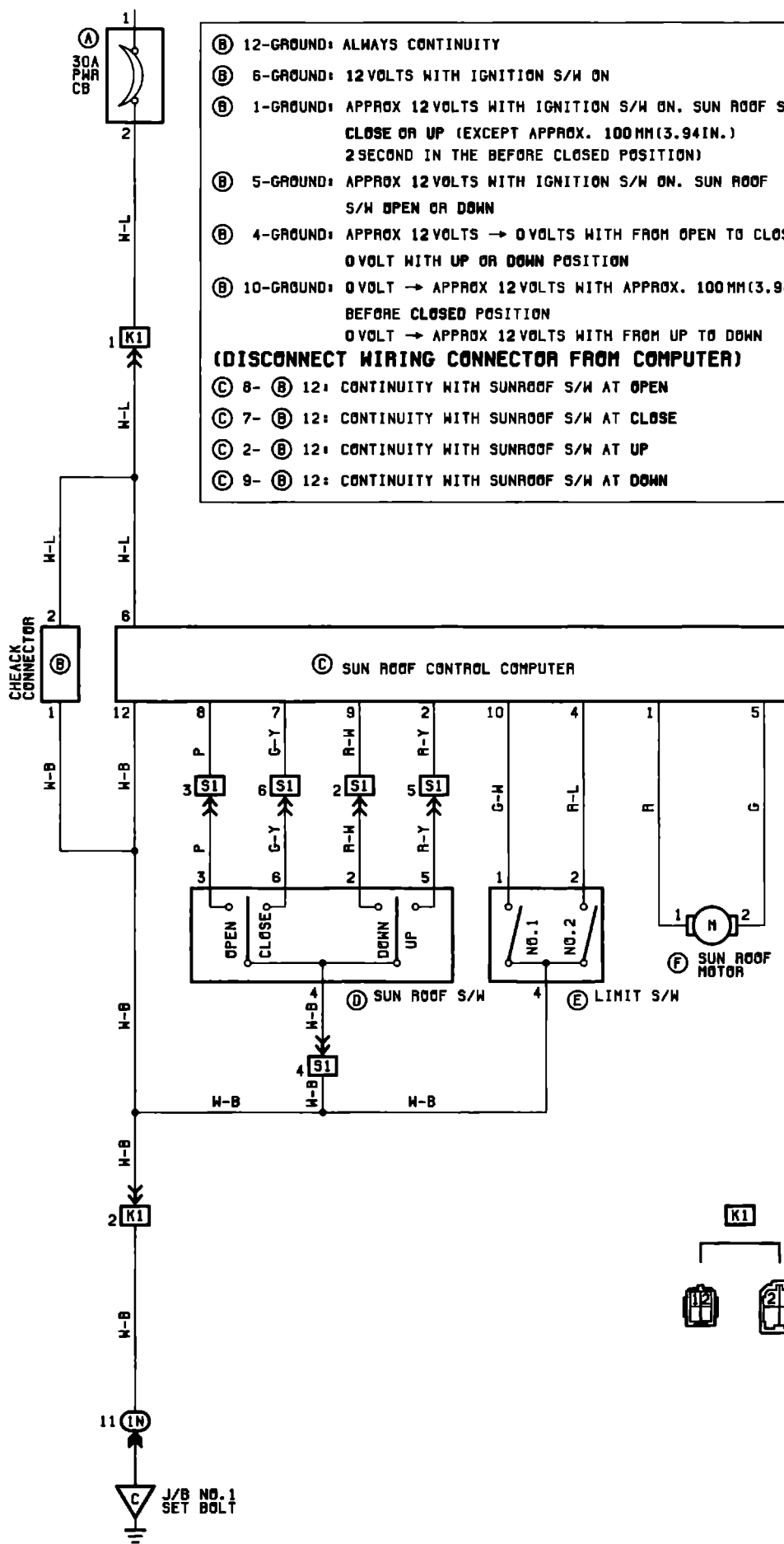

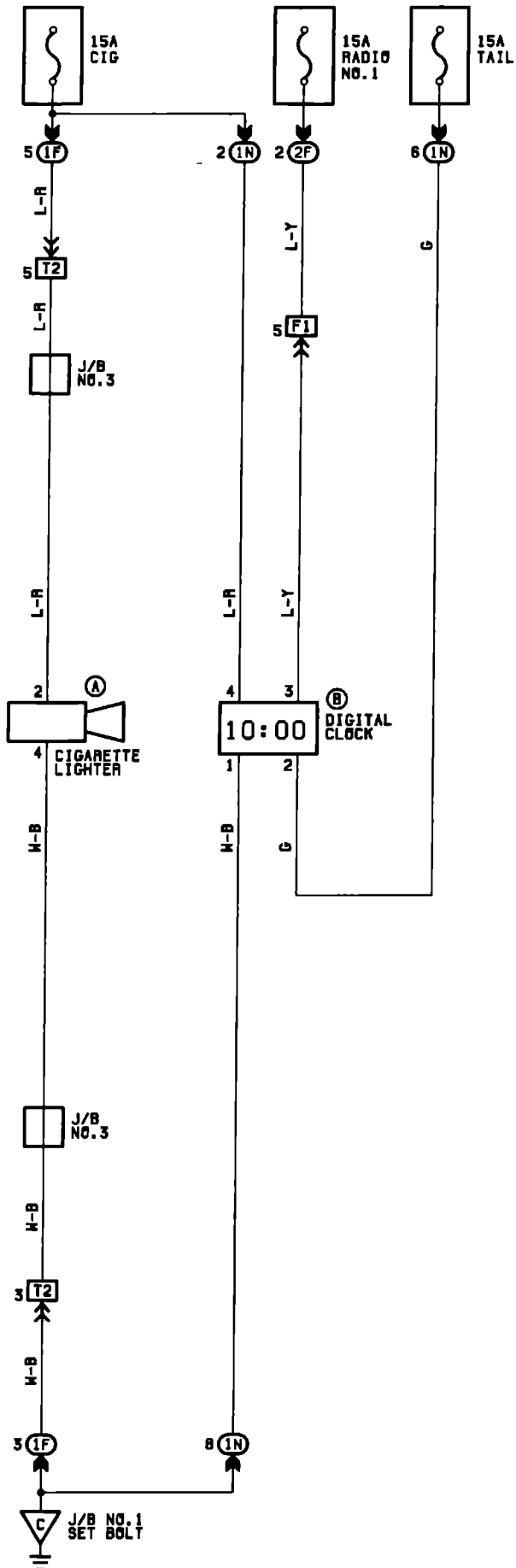

- Ⓐ CIGARETTE LIGHTER**
 2-GROUND: 12 VOLTS WITH IGNITION S/W AT IG OR ACC POSITION

Ⓑ DIGITAL CLOCK
 3-GROUND: ALWAYS 12 VOLTS (POWER FOR CLOCK)
 4-GROUND: 12 VOLTS WITH IGNITION S/W AT IG OR ACC POSITION (POWER FOR INDICATION)
 2-GROUND: 12 VOLTS WITH LIGHT CONTROL S/W AT TAIL OR HEAD POSITION (SIGNAL OF DIM INDICATION)
 1-GROUND: ALWAYS CONTINUITY

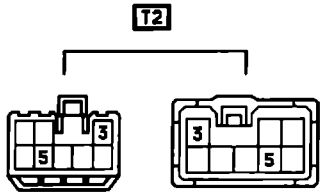
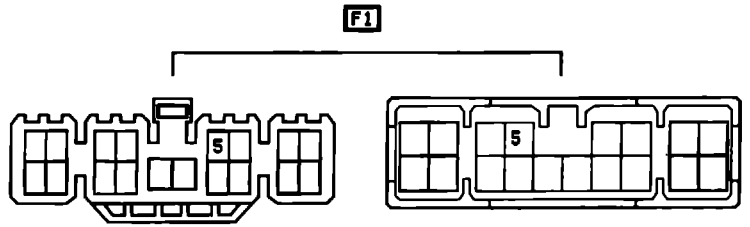
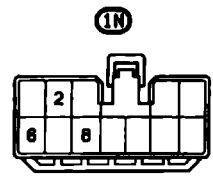
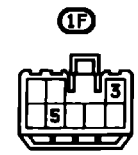
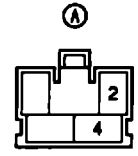

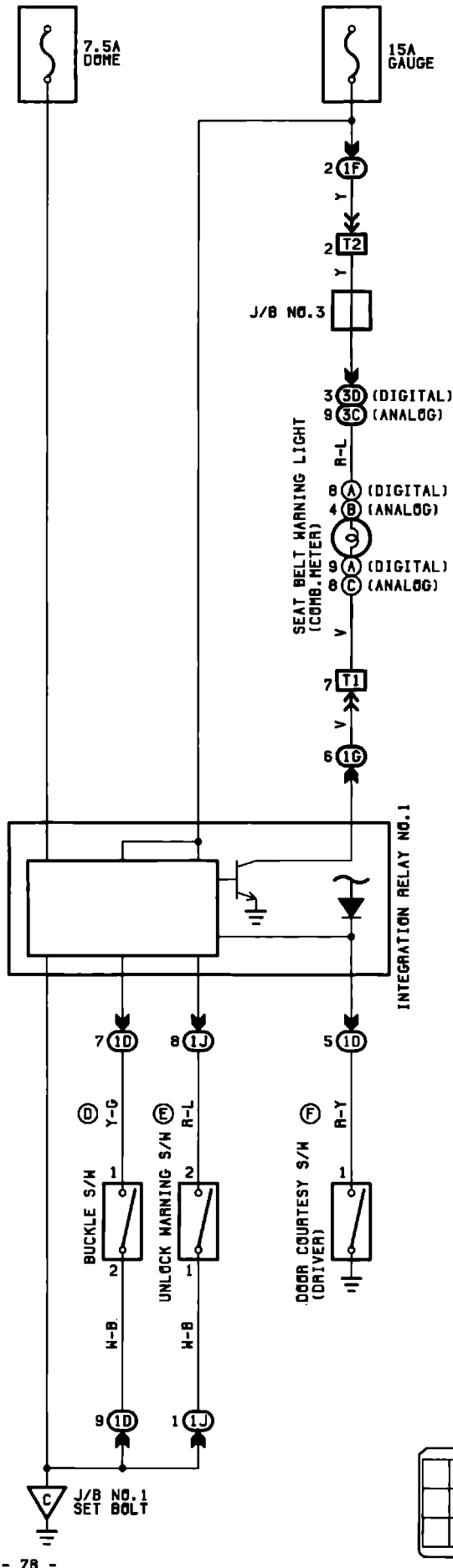

INTEGRATION RELAY NO. 1
 7.5A FUSE: ALWAYS 12V
 7.5A GAUGE FUSE: 12V WITH IGNITION S/W ON

(D) BUCKLE S/W
 1-2: CLOSED WITH DRIVER'S LAP BELT IN USE (FOR SEAT BELT WARNING)

(E) UNLOCK WARNING S/W
 2-1: CLOSED WITH IGNITION KEY IN CYLINDER (FOR UNLOCK WARNING)

(F) DOOR COURTESY S/W (DRIVER)
 1-GROUND: CLOSED WITH DRIVER'S DOOR OPEN (FOR UNLOCK WARNING)

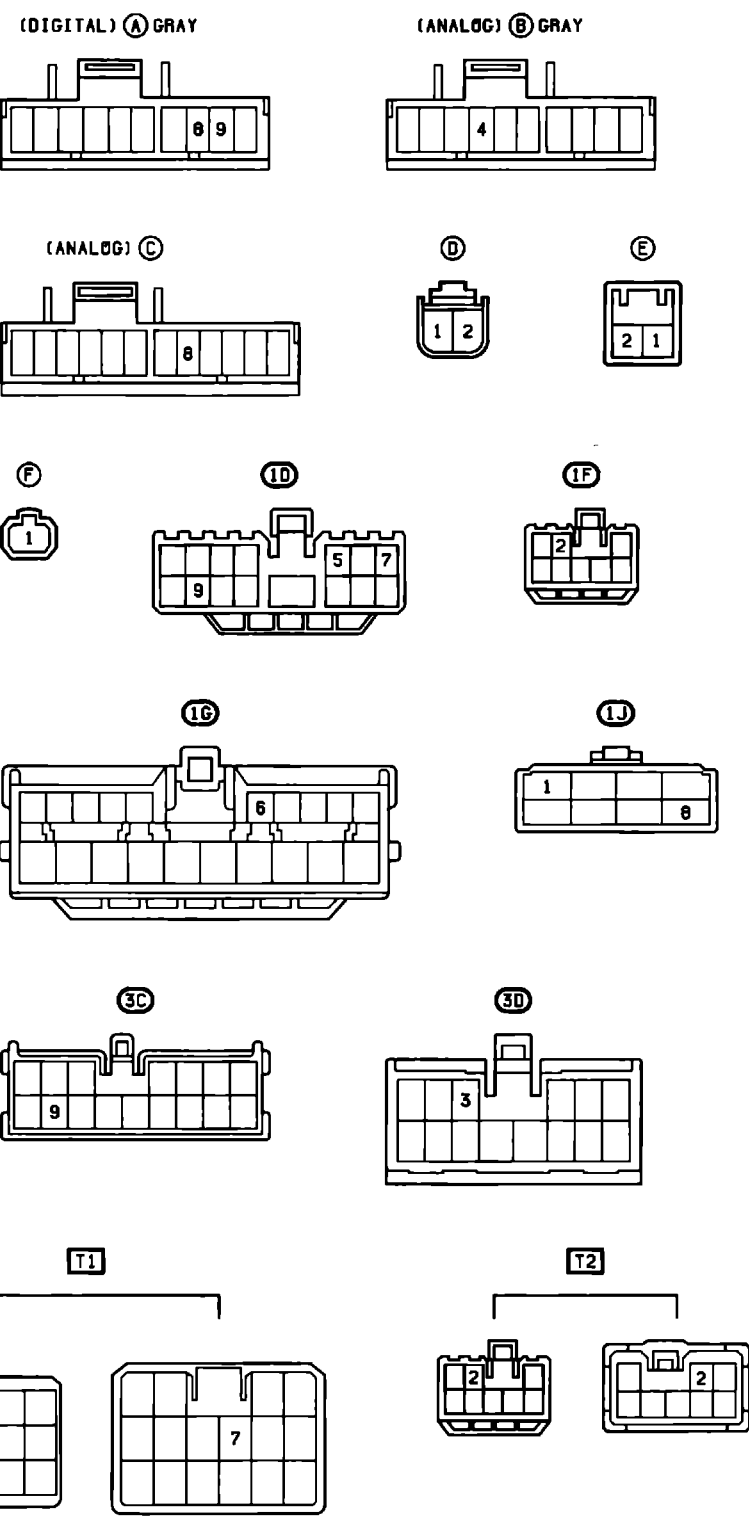

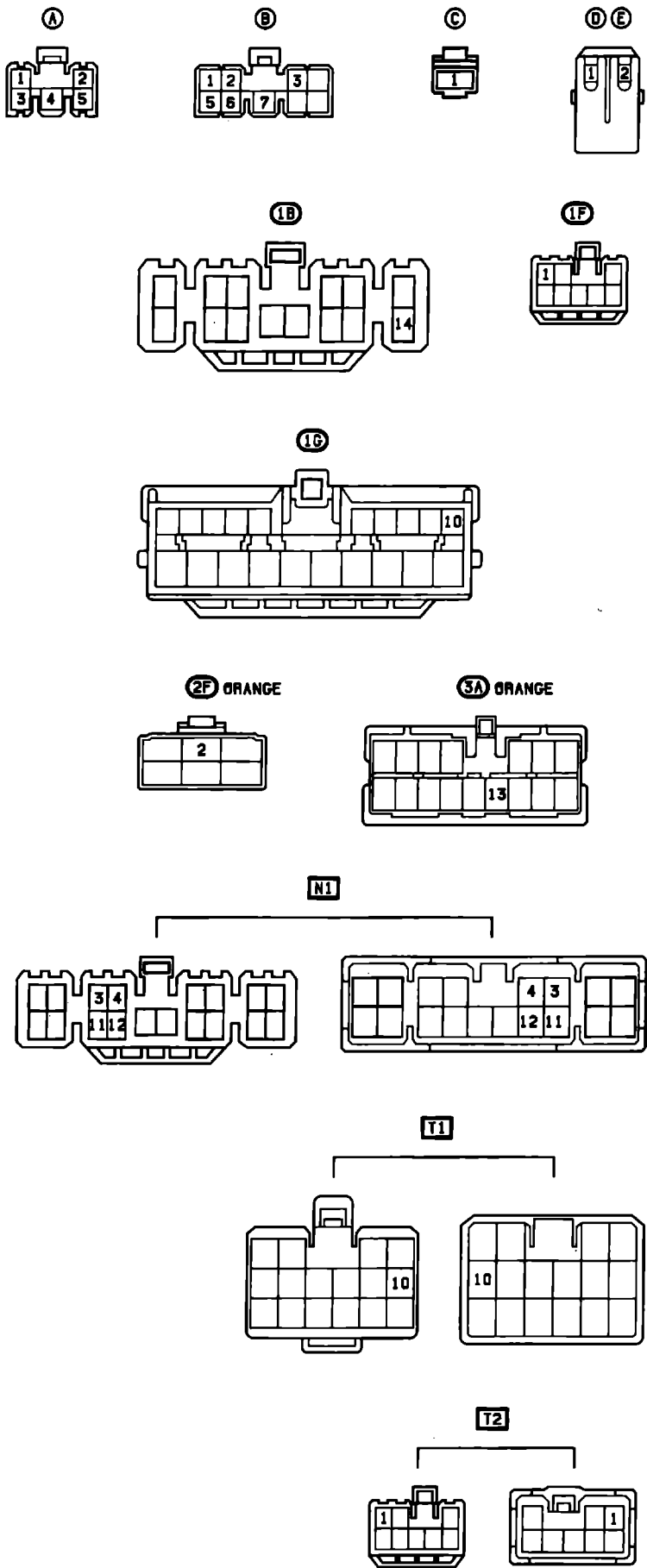
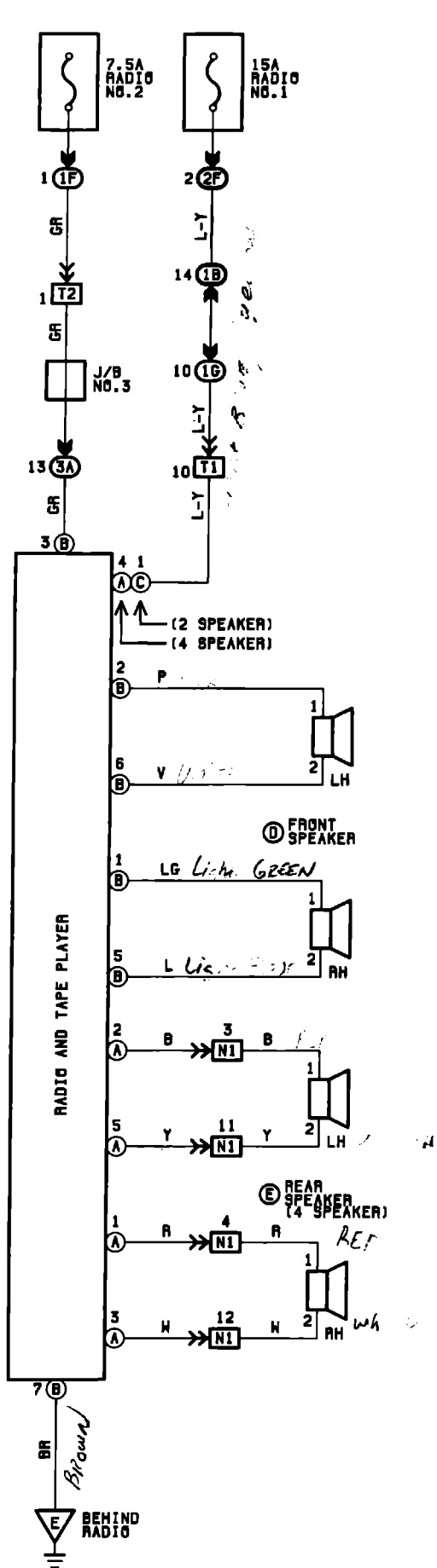

30-1 COMBINATION METER (ANALOG)

COMBINATION METER

Ⓐ 3-GROUND: 12 VOLTS WITH IGNITION S/W ON

Ⓒ 4-GROUND: 12 VOLTS WITH IGNITION S/W ON

Ⓒ 1, Ⓒ 5, Ⓒ 6-GROUND: ALWAYS CONTINUITY

FUEL LEVEL GAUGE

Ⓒ 4- Ⓒ 7 : APPROX. 101.9 Ω

Ⓒ 4- Ⓒ 5 : APPROX. 203.2 Ω

Ⓒ 7- Ⓒ 5 : APPROX. 101.3 Ω

OIL PRESSURE GAUGE

Ⓑ 2- Ⓒ 4 : APPROX. 42 Ω

WATER TEMP. GAUGE

Ⓒ 3- Ⓒ 4 : APPROX. 56 Ω

Ⓒ 4- Ⓒ 6 : APPROX. 201.8 Ω

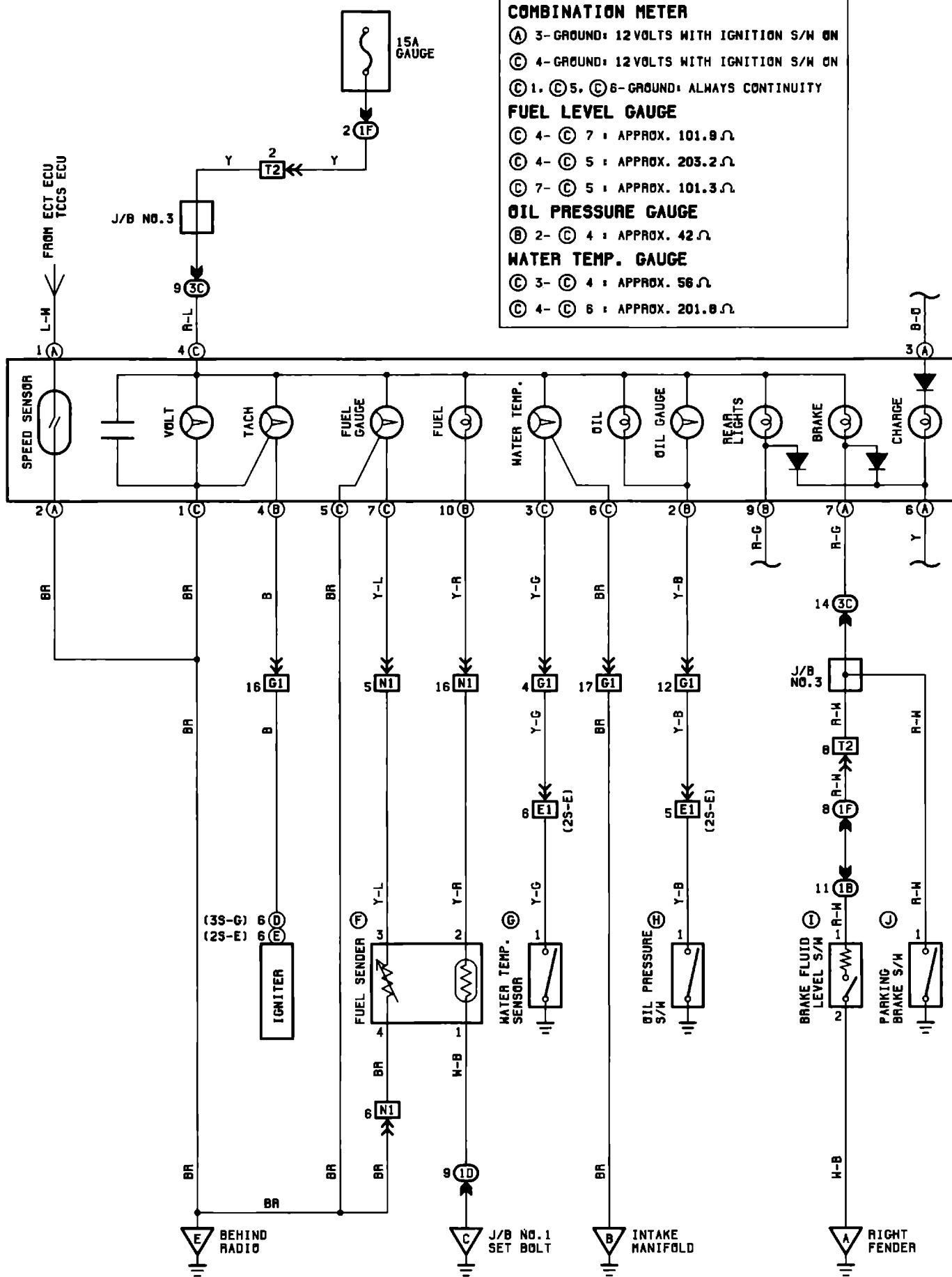

F FUEL SENDER
 3-4 : APPROX. 4Ω WITH FUEL FULL
 APPROX. 32.5Ω WITH FUEL HALF FULL
 APPROX. 110.0Ω WITH FUEL EMPTY

G WATER TEMP. SENDER
 (NIPPON DENSO MAKE)
 1-GROUND: APPROX. 226Ω AT 50°C (122°F)
 APPROX. 20Ω AT 115°C (239°F)
 (YAZAKI MAKE)
 1-GROUND: APPROX. 152.7Ω AT 80°C (140°F)
 APPROX. 28.4Ω AT 115°C (239°F)

H OIL PRESSURE S/W
 1-GROUND: CLOSED WITH OIL PRESSURE BELOW
 $0.2\text{KG}/\text{CM}^2$ (2.84PSI , 19.81KPA)

I BRAKE FLUID LEVEL S/W
 1-2 : CLOSED WITH FLOAT DOWN

J PARKING BRAKE S/W
 1-GROUND: CLOSED WITH PARKING BRAKE
 LEVER PULLED UP

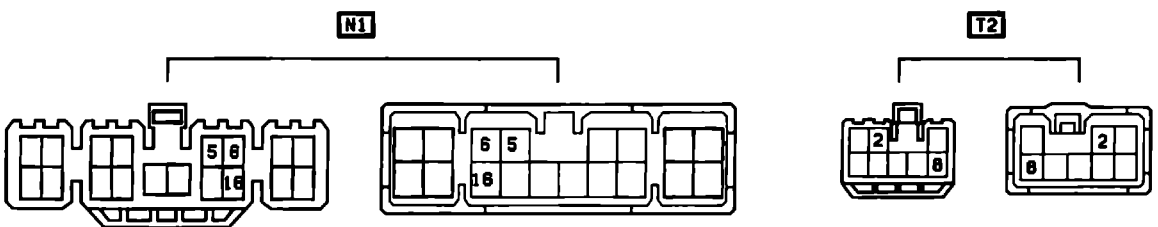
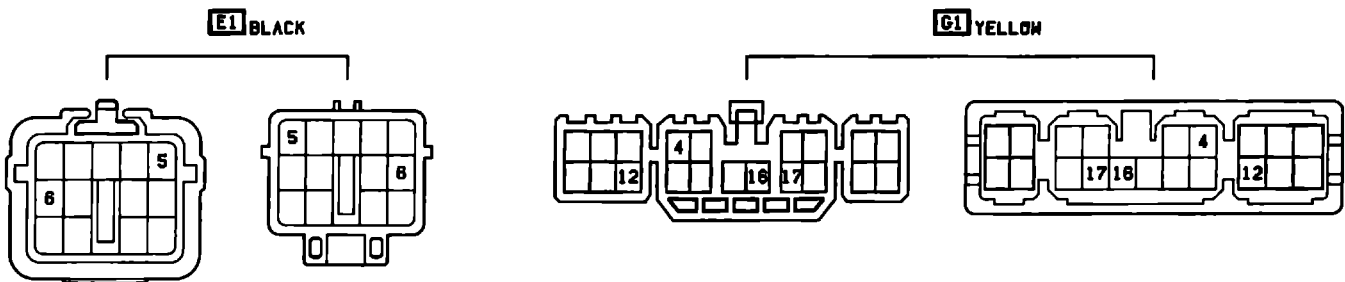
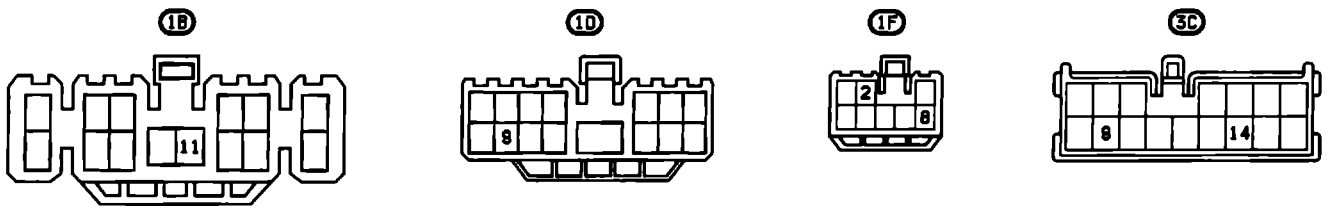
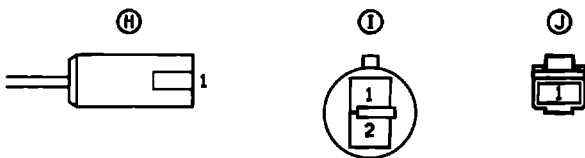
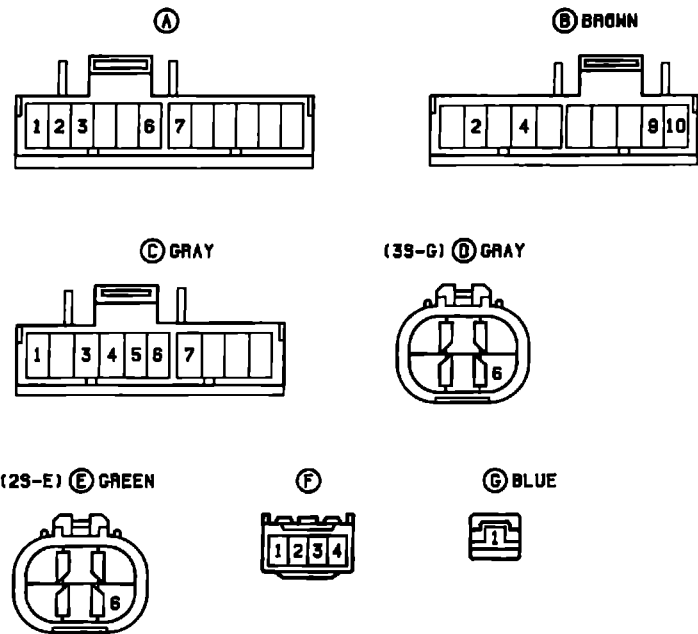

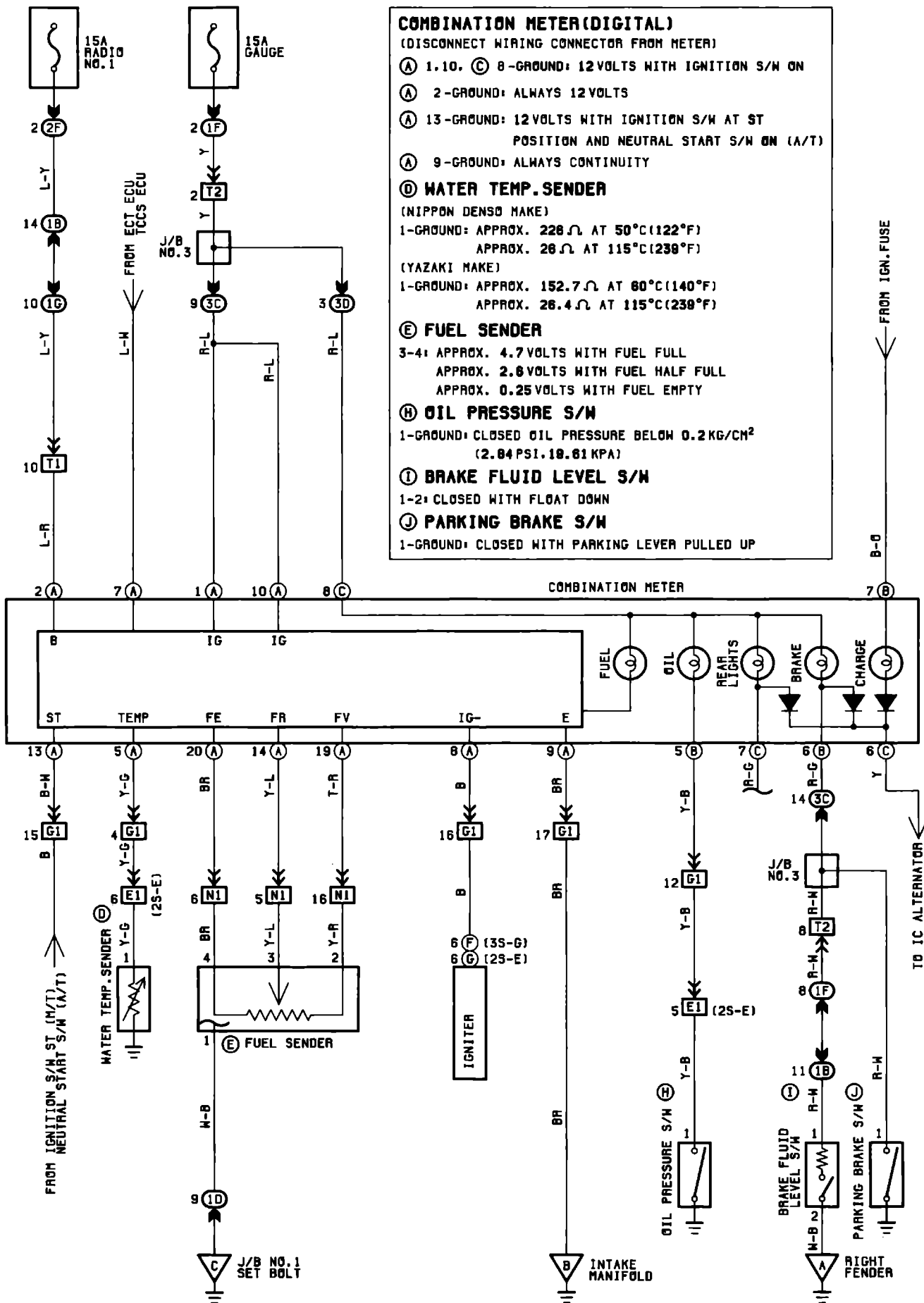

COMBINATION METER (DIGITAL)
 (DISCONNECT WIRING CONNECTOR FROM METER)

(A) 1.10, (C) 8-GROUND: 12 VOLTS WITH IGNITION S/W ON

(A) 2-GROUND: ALWAYS 12 VOLTS

(A) 13-GROUND: 12 VOLTS WITH IGNITION S/W AT ST POSITION AND NEUTRAL START S/W ON (A/T)

(A) 9-GROUND: ALWAYS CONTINUITY

(D) WATER TEMP. SENDER
 (NIPPON DENSO MAKE)
 1-GROUND: APPROX. 228 Ω AT 50°C (122°F)
 APPROX. 26 Ω AT 115°C (239°F)
 (YAZAKI MAKE)
 1-GROUND: APPROX. 152.7 Ω AT 60°C (140°F)
 APPROX. 26.4 Ω AT 115°C (239°F)

(E) FUEL SENDER
 3-4: APPROX. 4.7 VOLTS WITH FUEL FULL
 APPROX. 2.6 VOLTS WITH FUEL HALF FULL
 APPROX. 0.25 VOLTS WITH FUEL EMPTY

(H) OIL PRESSURE S/W
 1-GROUND: CLOSED OIL PRESSURE BELOW 0.2 KG/CM²
 (2.84 PSI, 19.61 KPA)

(I) BRAKE FLUID LEVEL S/W
 1-2: CLOSED WITH FLOAT DOWN

(J) PARKING BRAKE S/W
 1-GROUND: CLOSED WITH PARKING LEVER PULLED UP

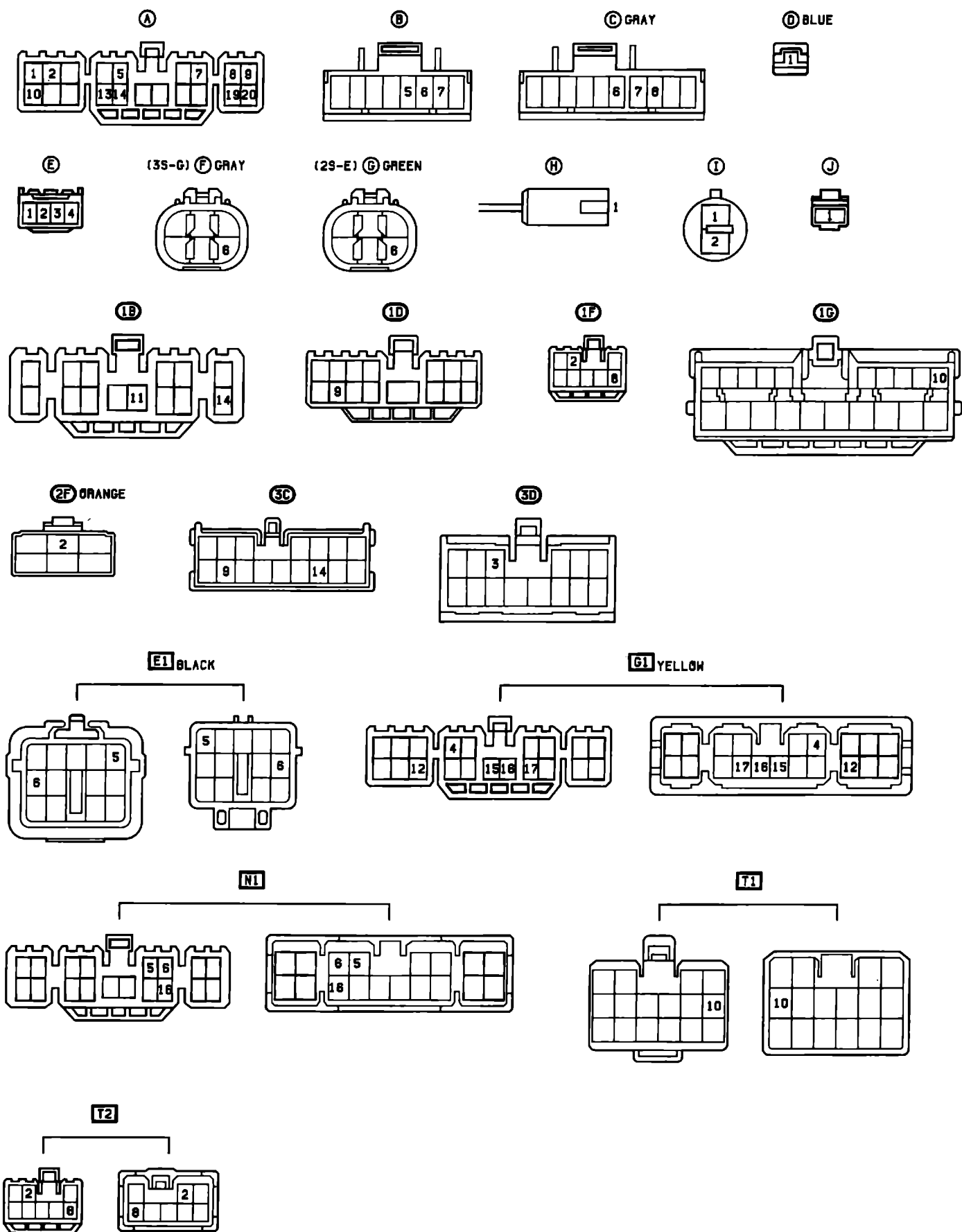

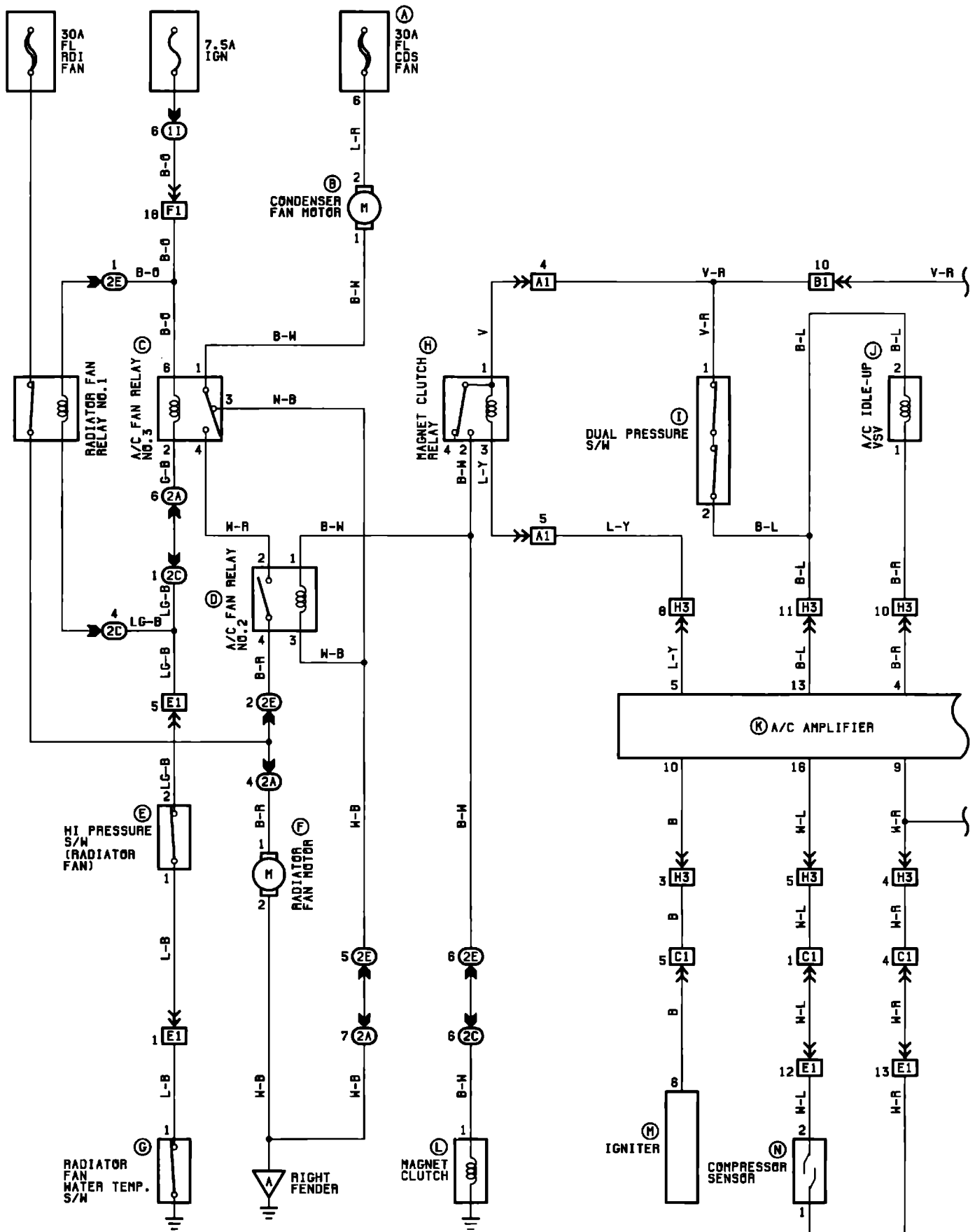

(LEVER SWITCH TYPE)

31-1

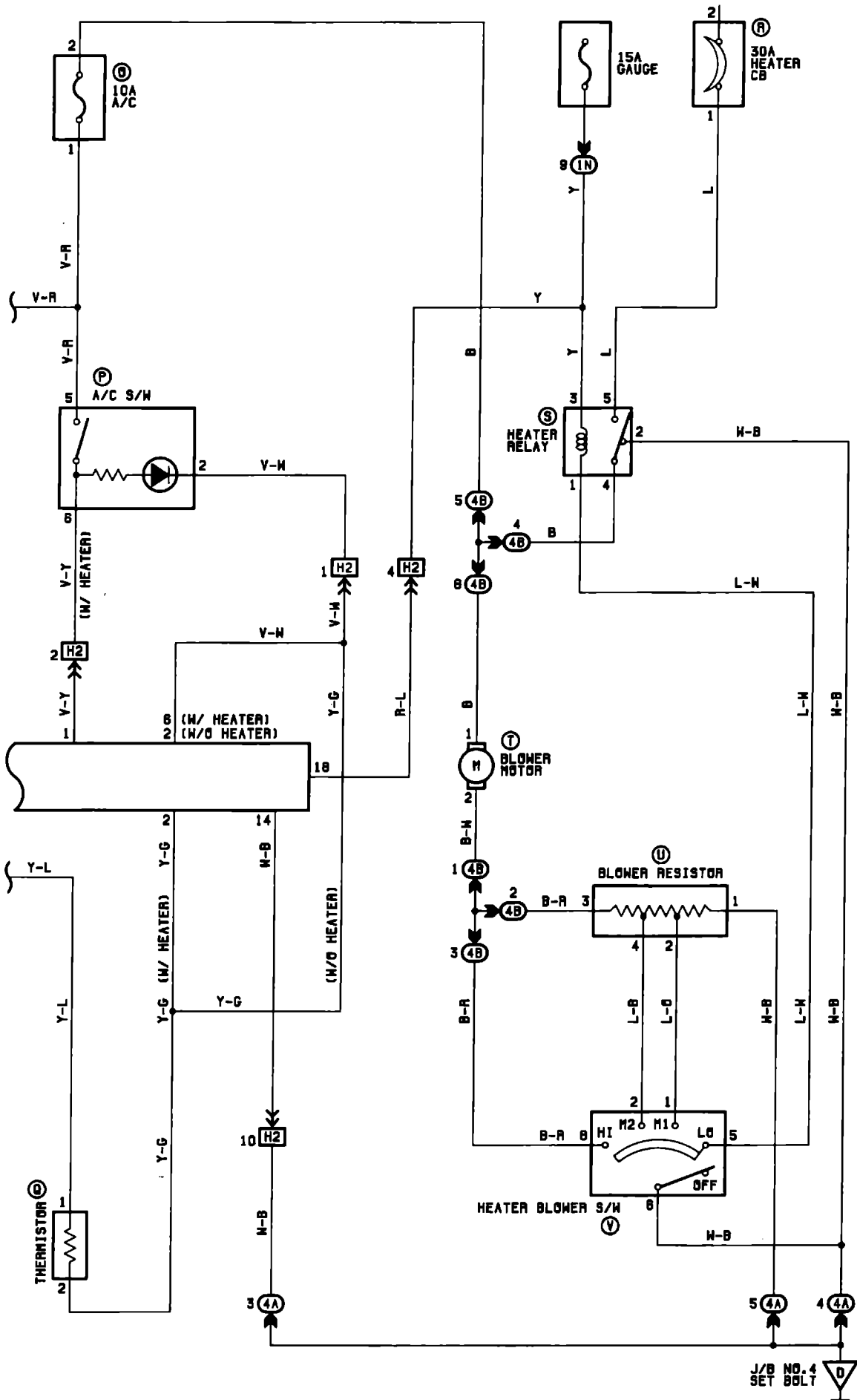

J/B NO. 4
SET BOLT

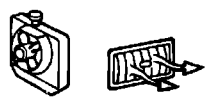

RADIATOR FAN RELAY NO.1
 OPEN WITH IGNITION S/W ON, A/C HI PRESSURE S/W ON OR WATER TEMP. S/W ON

(C) A/C FAN RELAY NO.3
 1-3: CLOSED WITH IGNITION S/W OFF OR A/C HI PRESSURE S/W OFF OR WATER TEMP. S/W OFF
 1-4: CLOSED WITH IGNITION S/W ON, A/C HI PRESSURE S/W ON AND WATER TEMP. S/W ON

(D) A/C FAN RELAY NO.2
 2-4: CLOSED WITH MAGNET CLUTCH ON

(E) HI PRESSURE S/W (RADIATOR FAN)
 1-2: OPEN ABOVE 18 KG/CM² (256 PSI, 1765 KPA)
 CLOSED BELOW 14 KG/CM² (199 PSI, 1373 KPA)

(G) RADIATOR FAN WATER TEMP. S/W
 1-GROUND: OPEN ABOVE 90°C (194°F)
 CLOSED BELOW 83°C (181°F)

(I) DUAL PRESSURE S/W
 1-2: OPEN WITH PRESSURE LESS THAN 2.1 KG/CM² (30 PSI, 208 KPA) OR ABOVE 27 KG/CM² (384 PSI, 2648 KPA)

(J) A/C IDLE-UP VSV
 1-2: APPROX. 40Ω

(L) MAGNET CLUTCH
 1-GROUND: APPROX. 3.7Ω

(O) THERMISTOR
 APPROX. 1.5KΩ AT 25°C (77°F)

(S) HEATER RELAY
 4-5: CLOSED WITH IGNITION S/W ON AND BLOWER S/W ON

(U) BLOWER RESISTOR
 1-2: APPROX. 1.5Ω
 2-4: APPROX. 0.8Ω
 3-4: APPROX. 0.4Ω

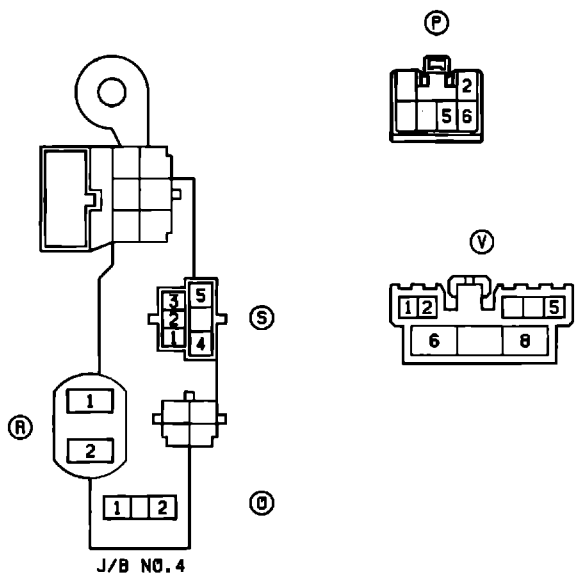
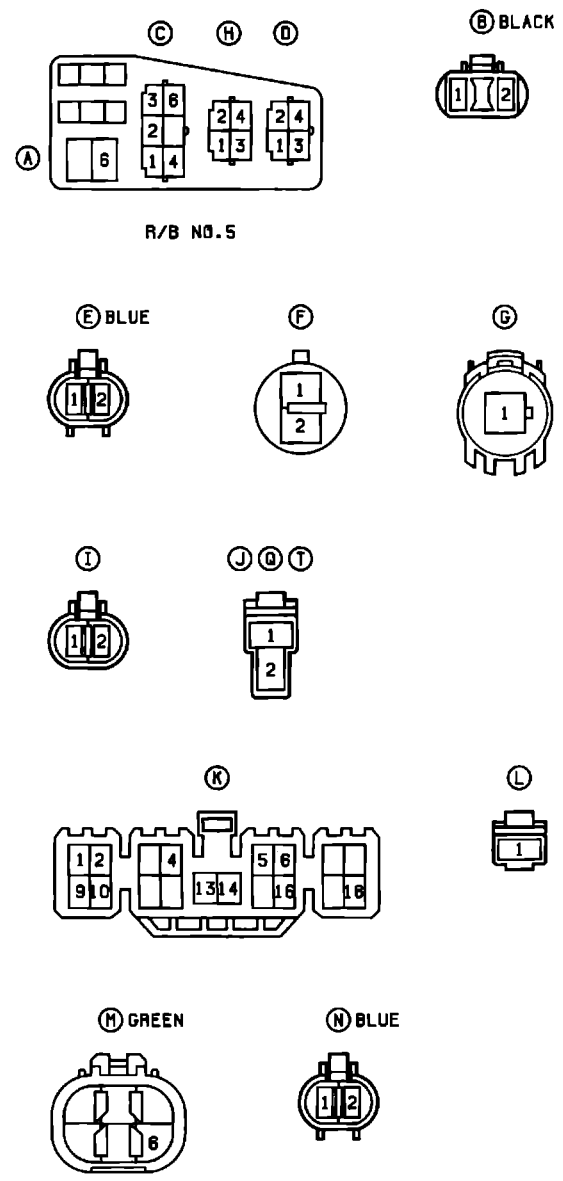

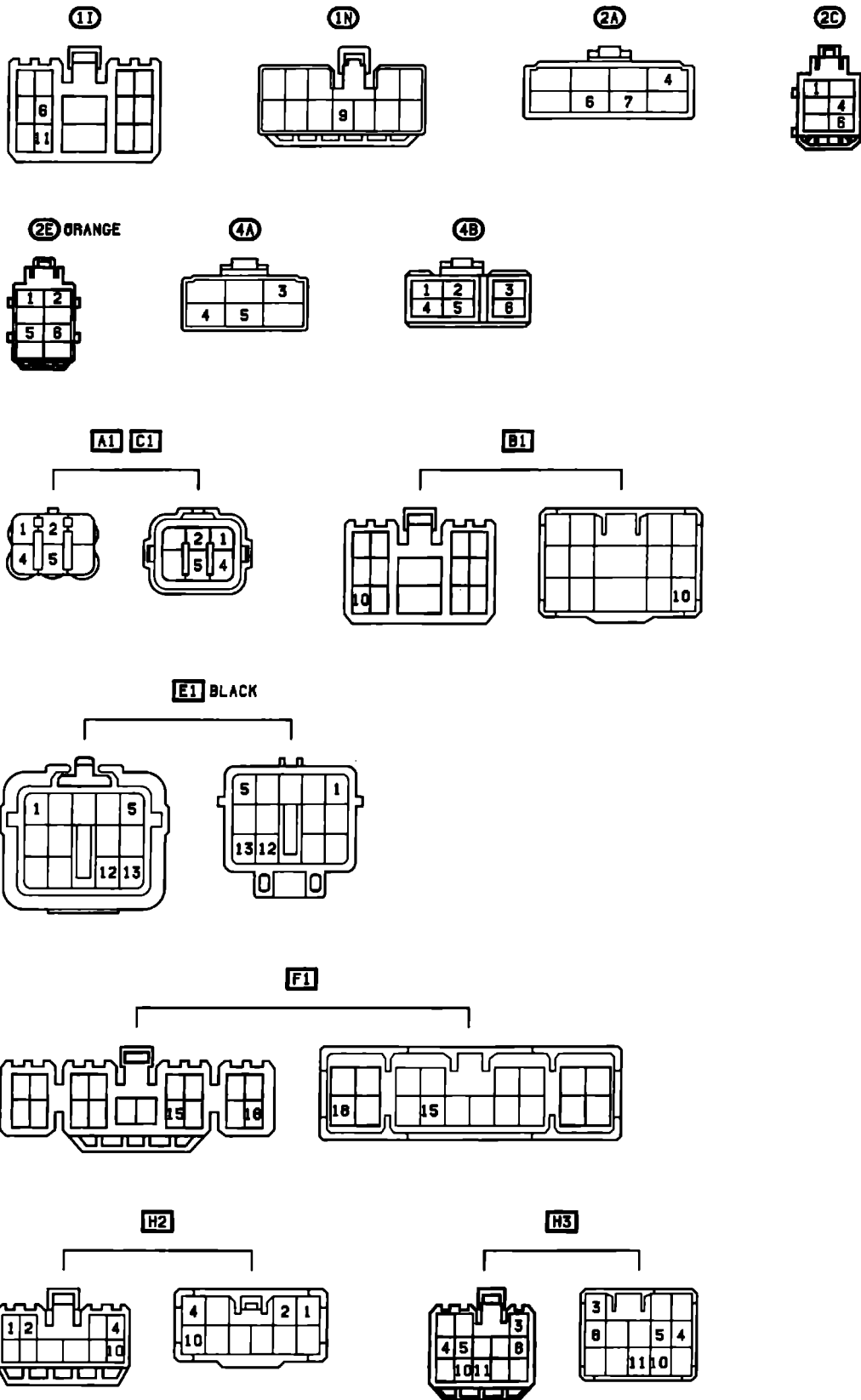

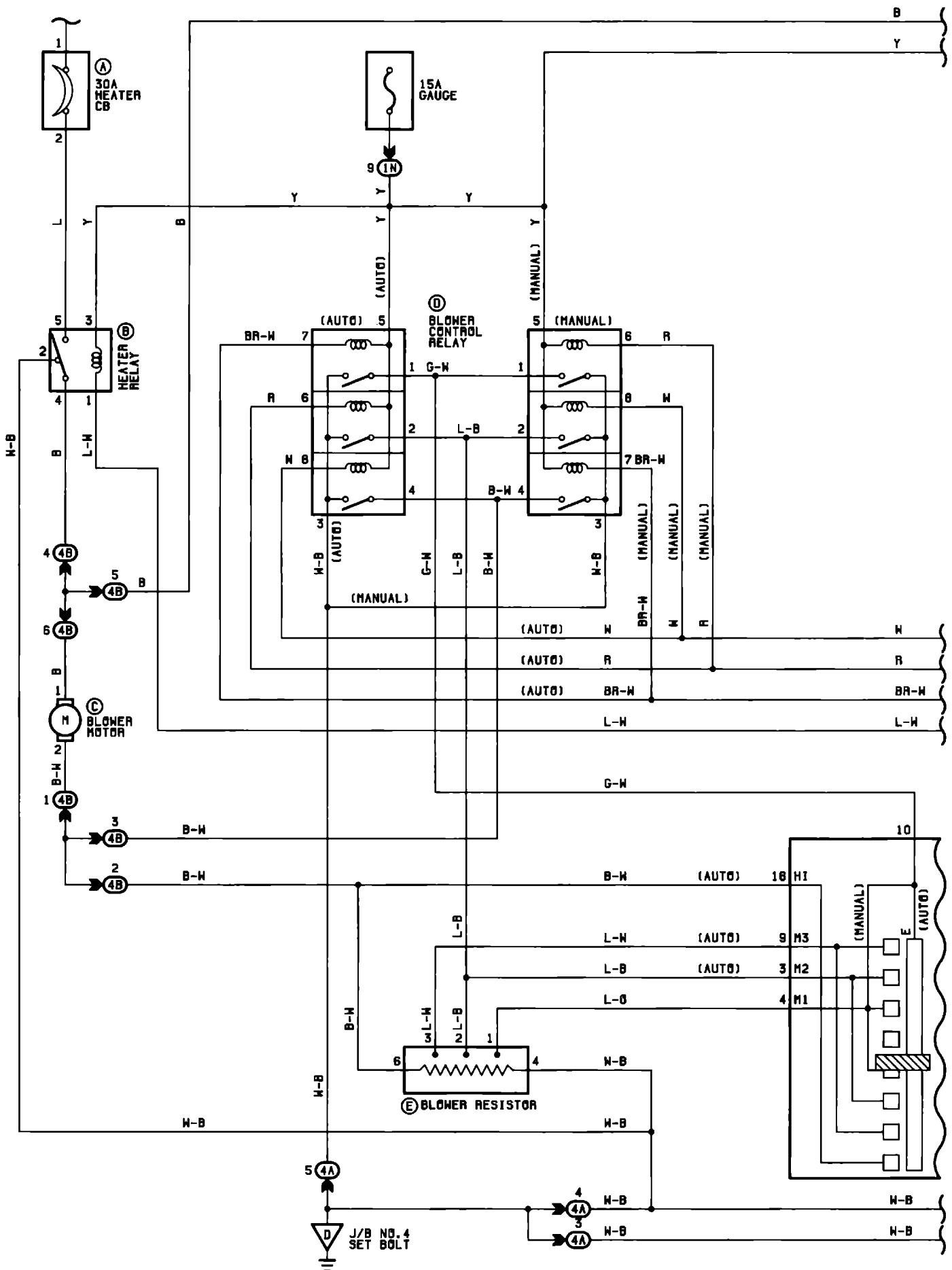

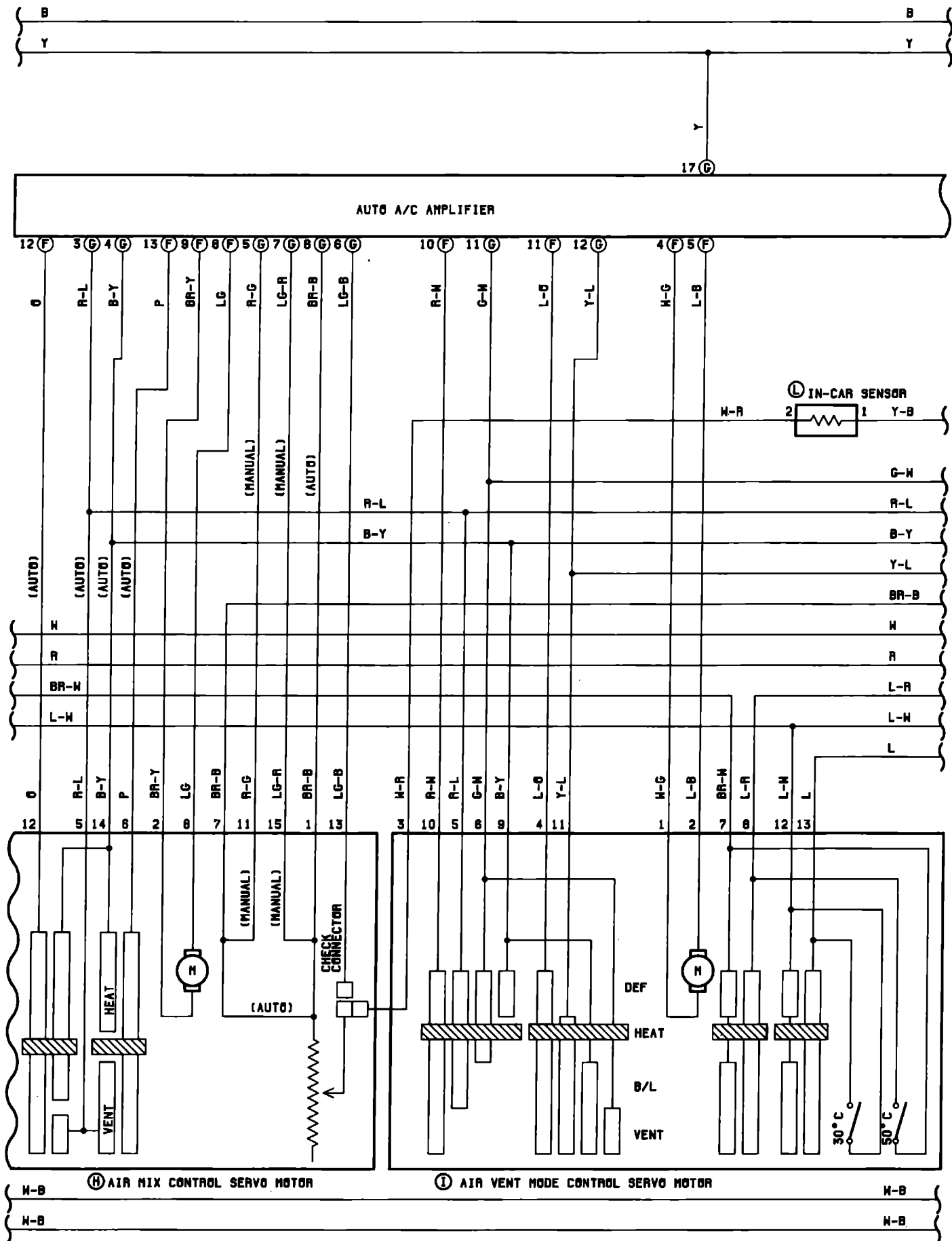



RADIATOR FAN AND AIR CONDITIONER

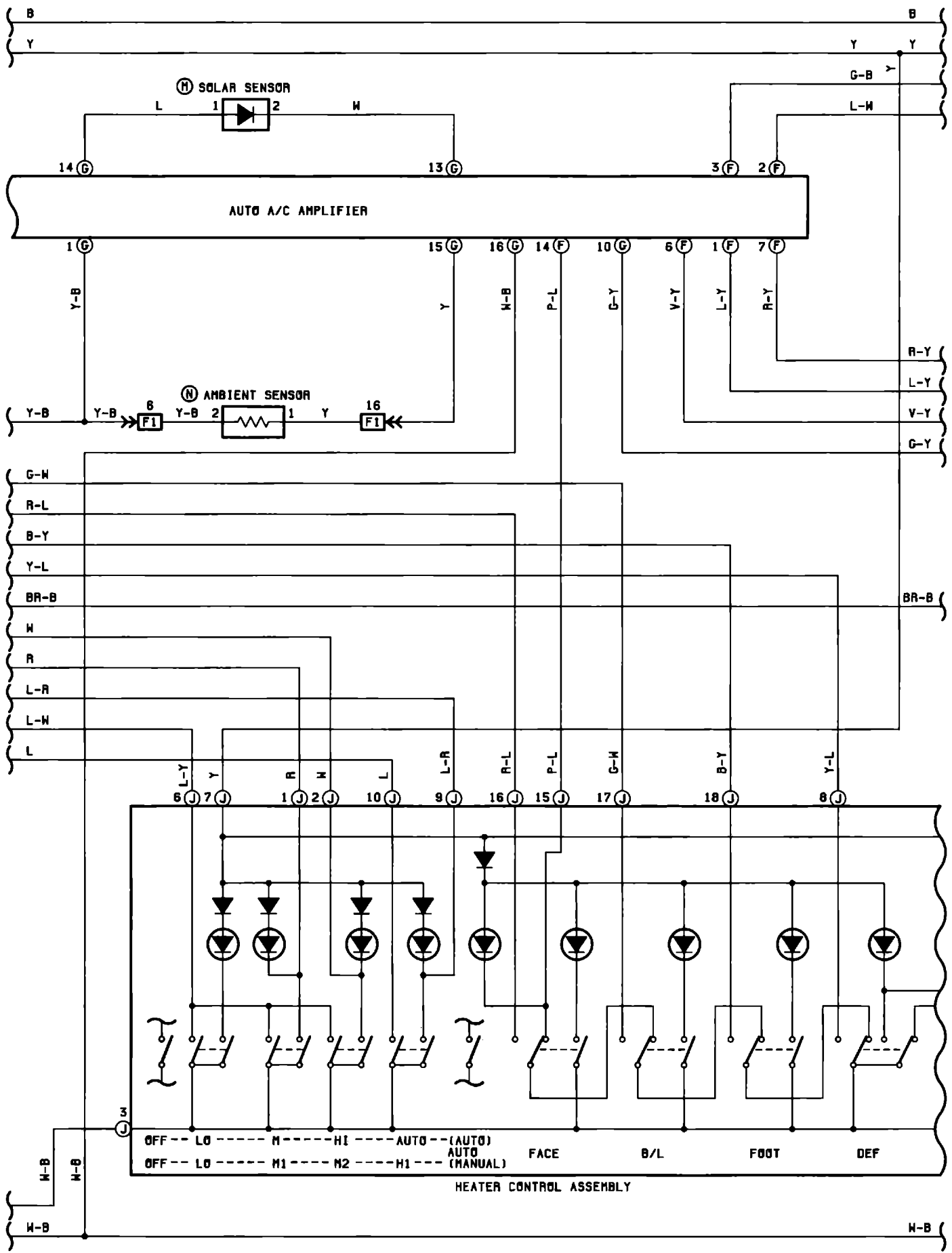



RADIATOR FAN AND AIR CONDITIONER

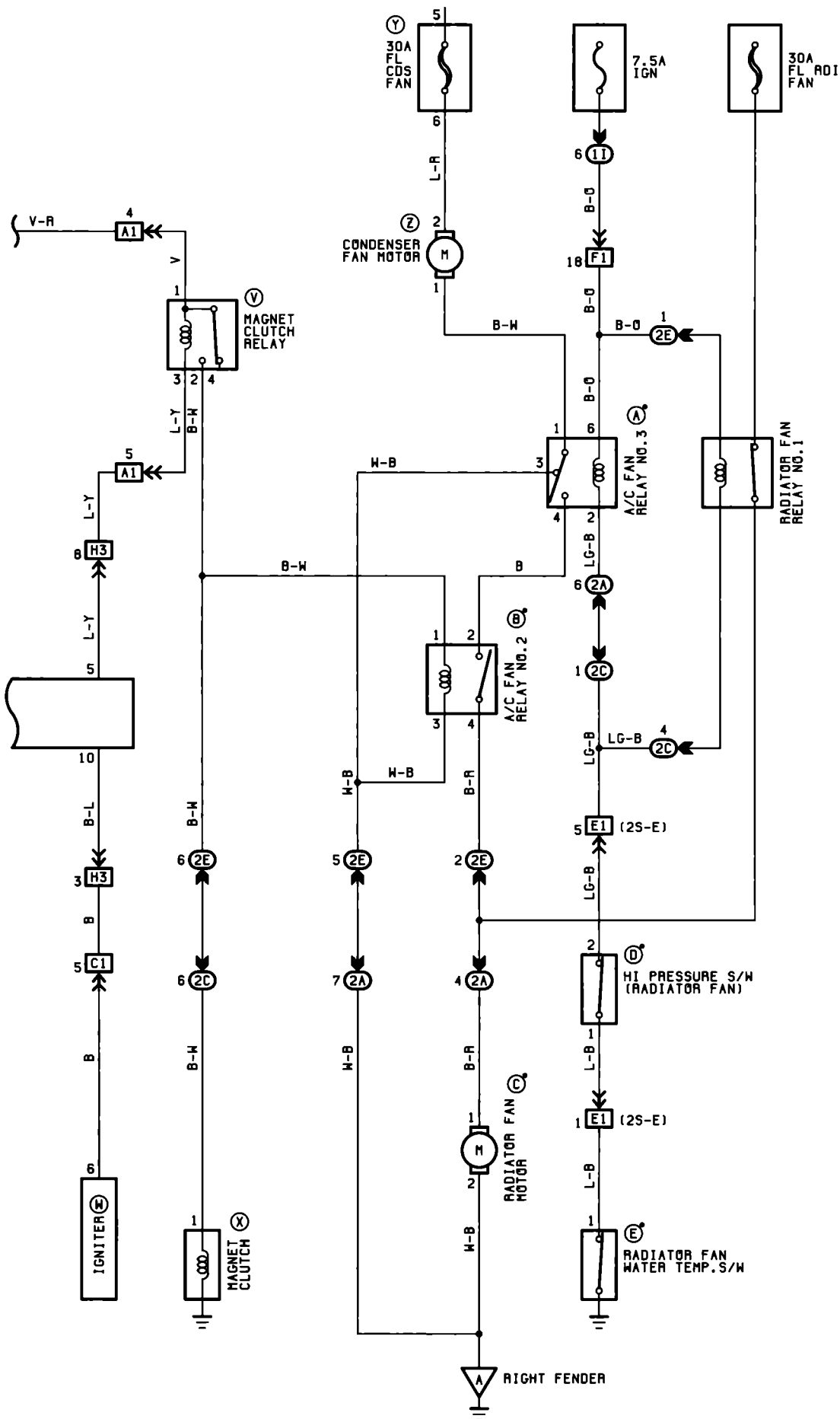

RADIATOR FAN RELAY NO.1

OPEN WITH IGNITION S/W ON, A/C HI PRESSURE S/W ON OR WATER TEMP. S/W ON

ⓑ HEATER RELAY

4-5: CLOSED WITH IGNITION S/W ON AND BLOWER S/W ON

Ⓔ BLOWER RESISTOR (MANUAL)

1-2: APPROX. 0.80 Ω
1-4: APPROX. 1.50 Ω
2-6: APPROX. 0.40 Ω

Ⓕ BLOWER RESISTOR (AUTO)

6-3: APPROX. 0.22 Ω
3-2: APPROX. 0.33 Ω
2-1: APPROX. 0.78 Ω
1-4: APPROX. 1.37 Ω

ⓓ AIR MIX CONTROL SERVO MOTOR

3, 4, 9 OR 15-10: EACH CLOSED WITH SERVO SHAFT MOVEMENT
1-7 : RESISTANCE CHANGES RESPECTIVELY WITH SERVO SHAFT MOVEMENT 1.8K Ω AT MAX. COOL POSITION 350-450 Ω AT MAX. HOT POSITION

ⓔ AIR VENT MODE CONTROL SERVO MOTOR

12-13(7-8): CLOSED WITH COOLANT TEMP. BELOW 30°C, 86°F (50°C, 122°F) OR HEATER CONTROL S/W A/T FACE, B/L OR DEF POSITION

ⓙ HEATER CONTROL ASSEMBLY

13-14: MORE THAN 2700 Ω WITH CONTROL LEVER AT COOL POSITION
LESS THAN 290 Ω WITH CONTROL LEVER AT WARM POSITION
APPROX. 1500 Ω WITH CONTROL LEVER AT MIDDLE POSITION
25°C (77°F)

ⓐ A/C IDLE-UP VSV

1-2: APPROX. 40 Ω

Ⓡ DUAL PRESSURE S/W

1-2: OPEN WITH PRESSURE LESS THAN 2.1 KG/CM² (30 PSI, 206 KPA) OR ABOVE 27 KG/CM² (384 PSI, 2648 KPA)

Ⓧ MAGNET CLUTCH

1-GROUND: APPROX. 3.7 Ω

ⓐ A/C FAN RELAY NO.3

1-3: CLOSED WITH IGNITION S/W OFF OR A/C HI PRESSURE S/W OFF OR WATER TEMP. S/W OFF

1-4: CLOSED WITH IGNITION S/W ON, A/C HI PRESSURE S/W ON AND WATER TEMP. S/W ON

ⓑ A/C FAN RELAY NO.2

2-4: CLOSED WITH MAGNET CLUTCH ON

ⓓ HI PRESSURE S/W (RADIATOR FAN)

1-2: OPEN ABOVE 18 KG/CM² (258 PSI, 1765 KPA) CLOSED BELOW 14 KG/CM² (199 PSI, 1373 KPA)

Ⓔ RADIATOR FAN WATER TEMP. S/W

1-GROUND: OPEN ABOVE 90°C (194°F) CLOSED BELOW 83°C (181°F)

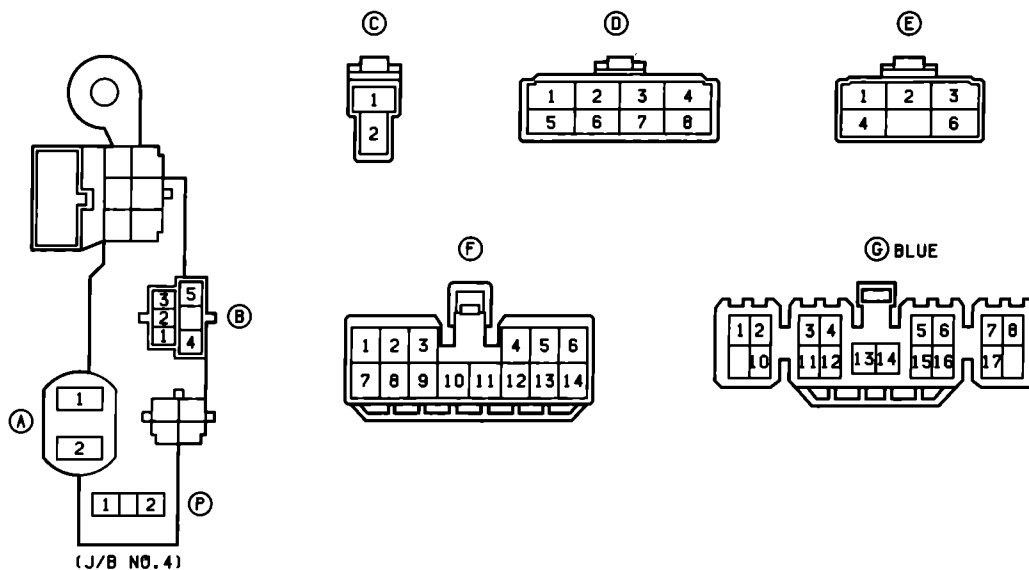

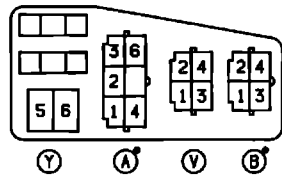
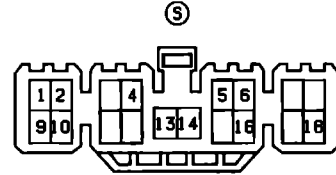
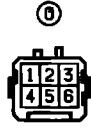
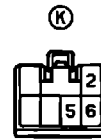
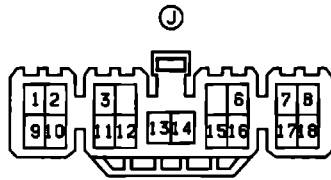
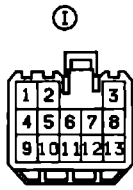
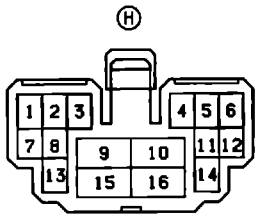

(3S-G) H GRAY

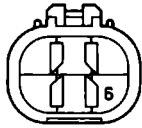

(2S-E) H GREEN

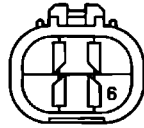

X



Z BLACK



C



D BLUE



E



1J

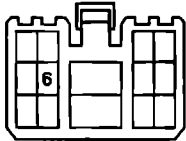

1N

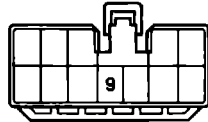

2A

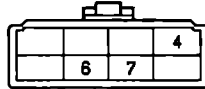

2C

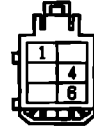

2E ORANGE

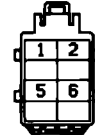

4A

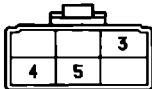

4B

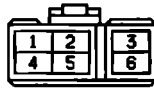

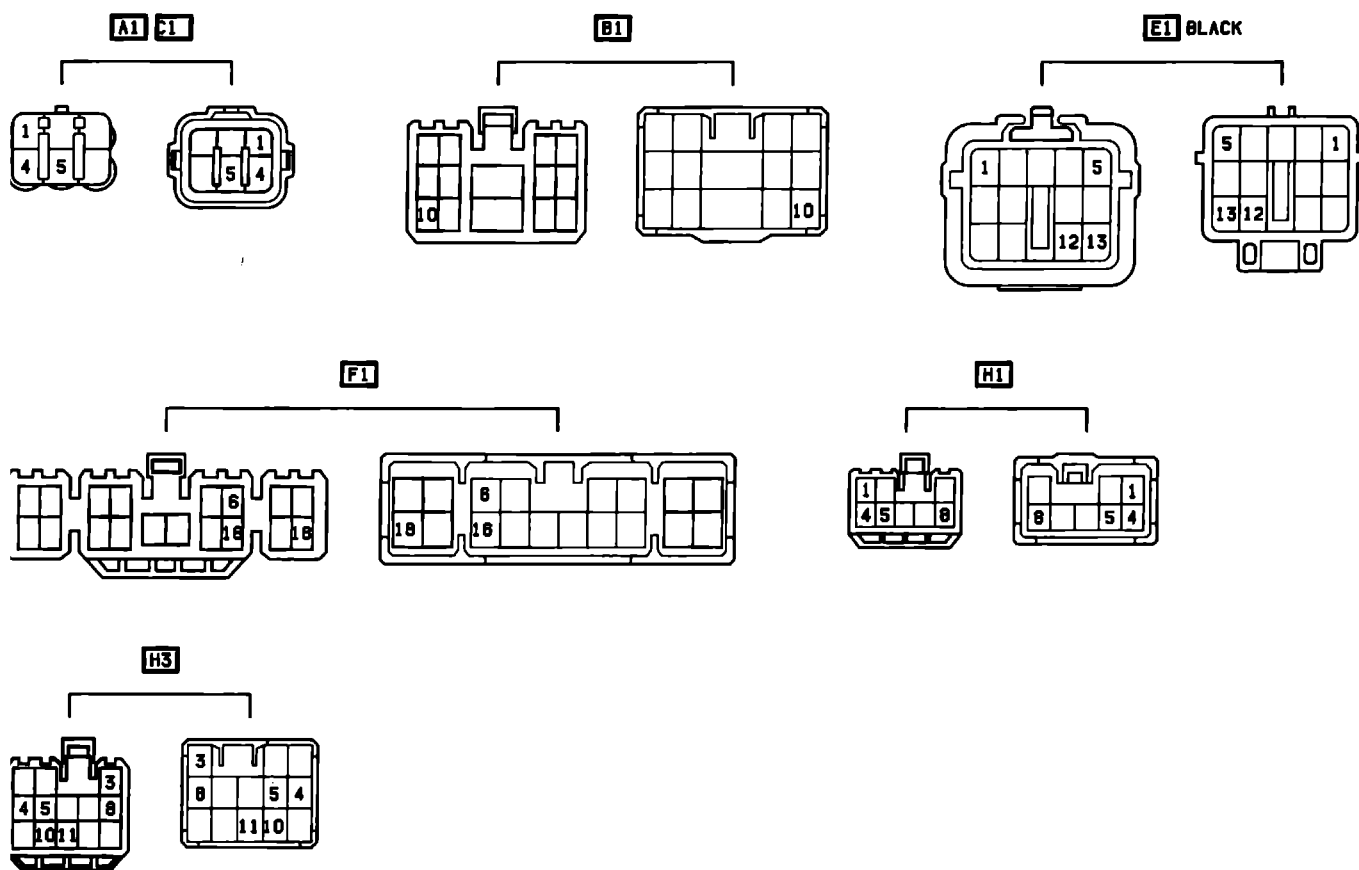

32 GROUND POINTS

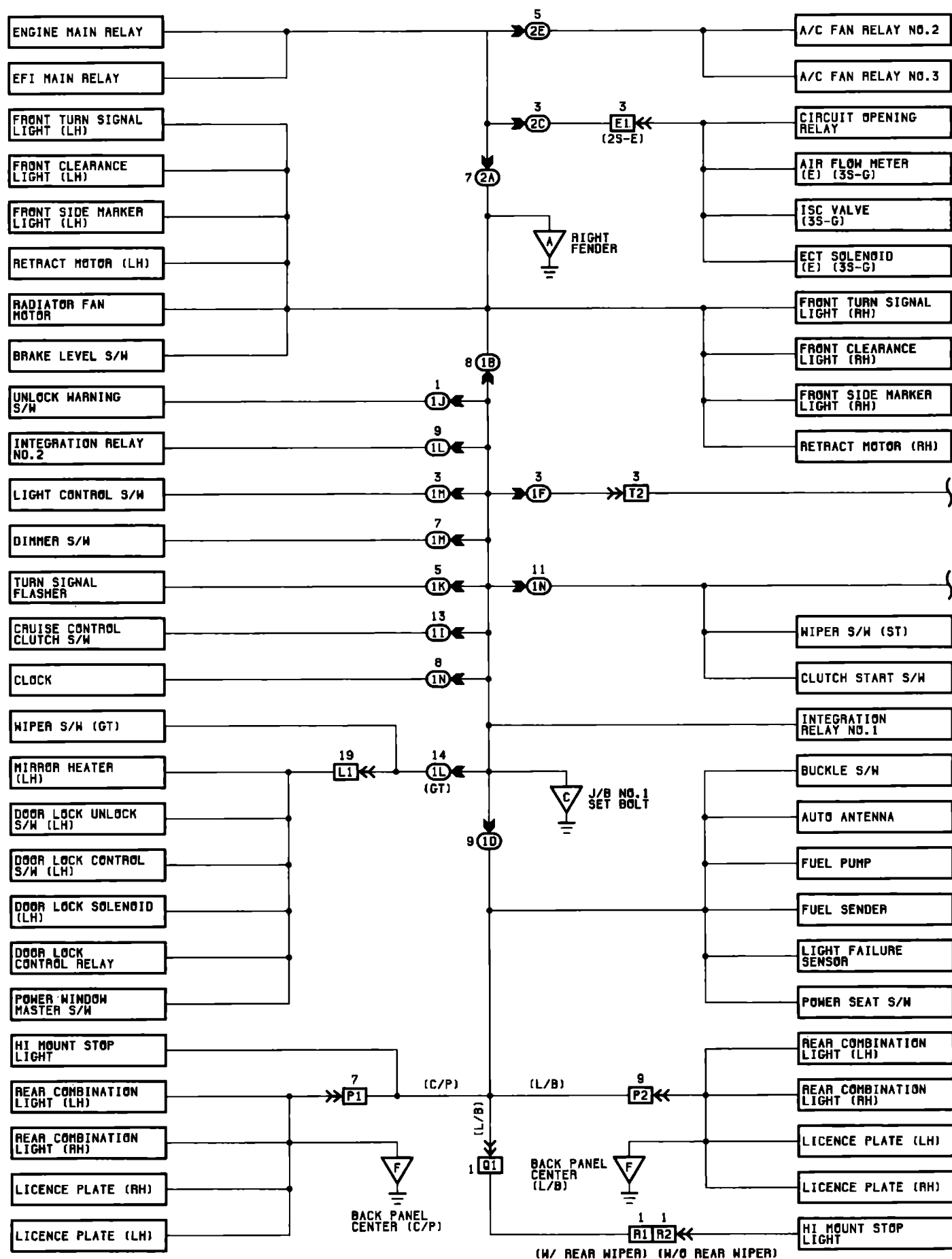

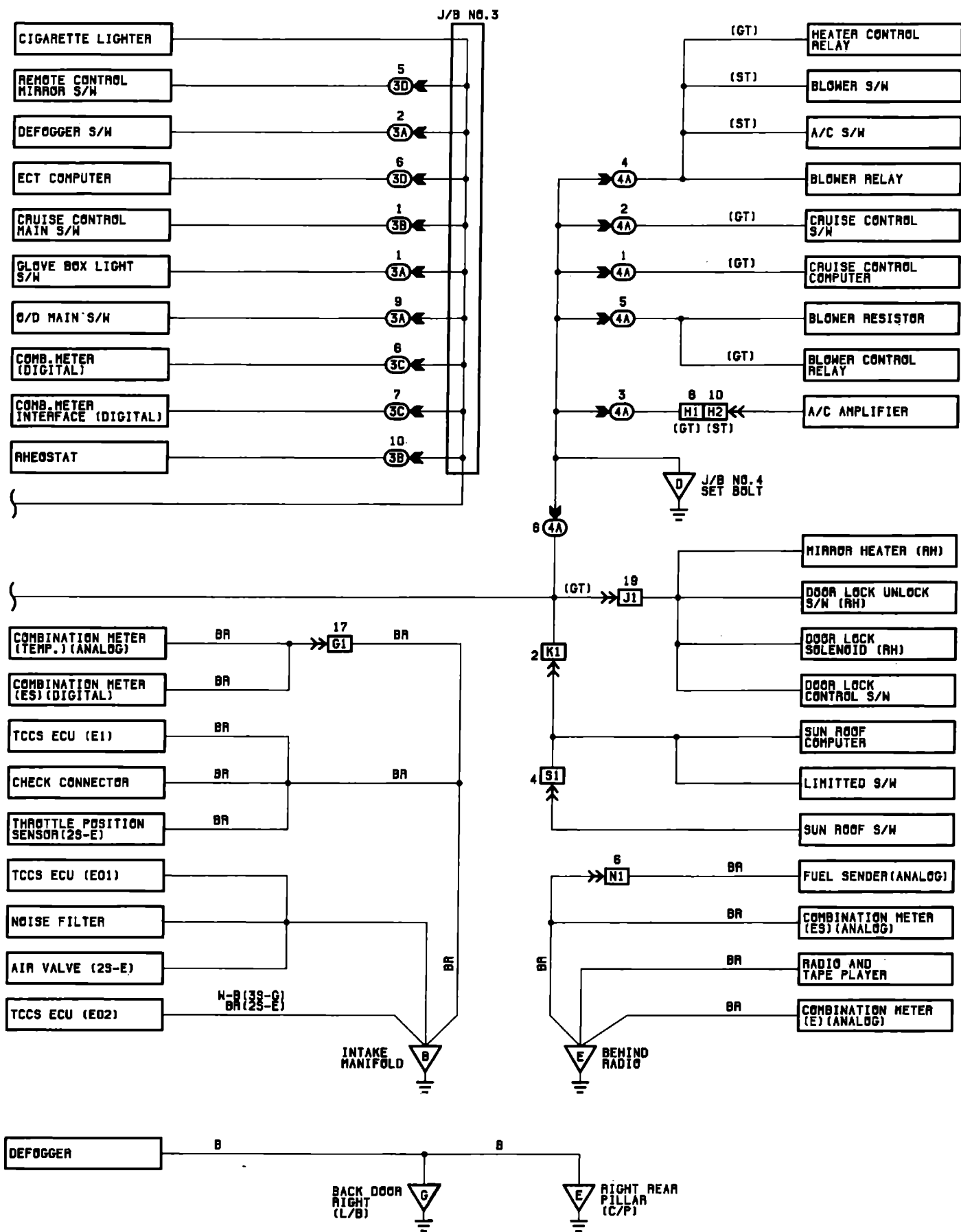

32 GROUND POINTS

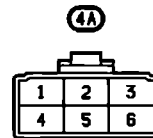
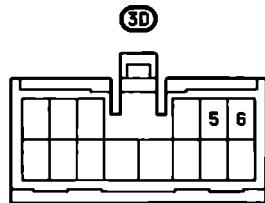
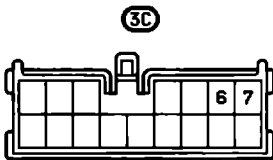
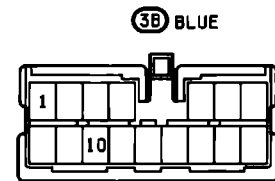
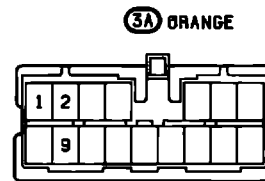
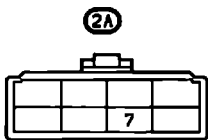
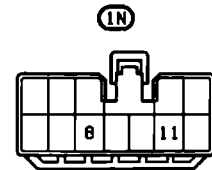
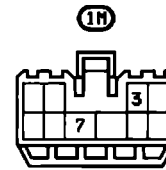
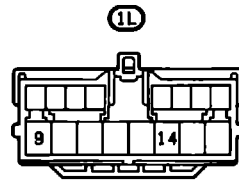
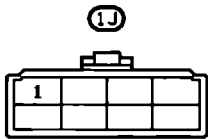
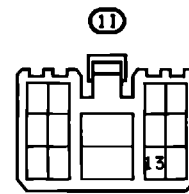
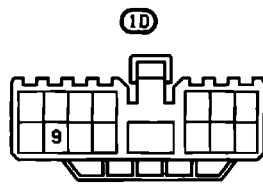
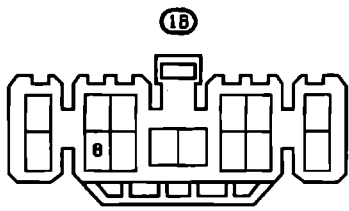

(2S-E) E1 BLACK

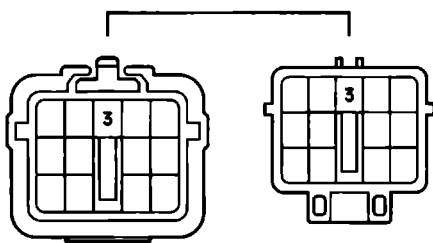

G1 YELLOW

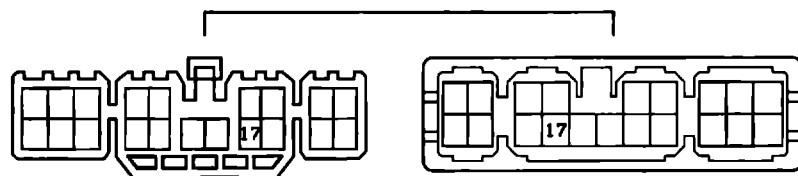

H1

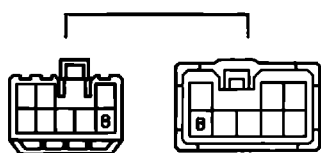

H2

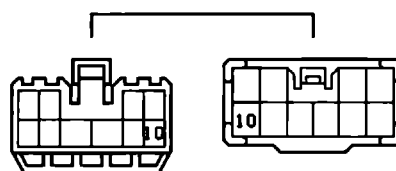

J1 L1 BLUE

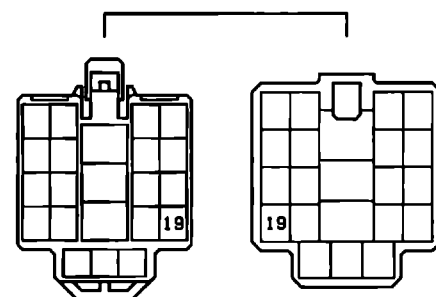

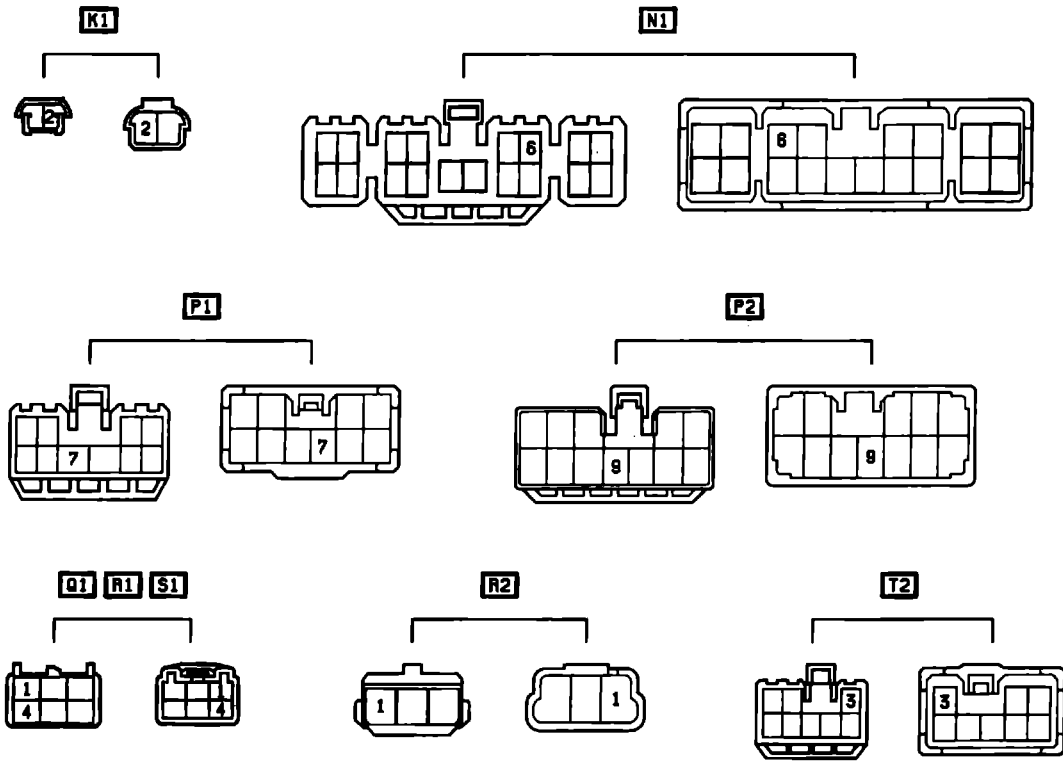

RELAY LOCATIONS

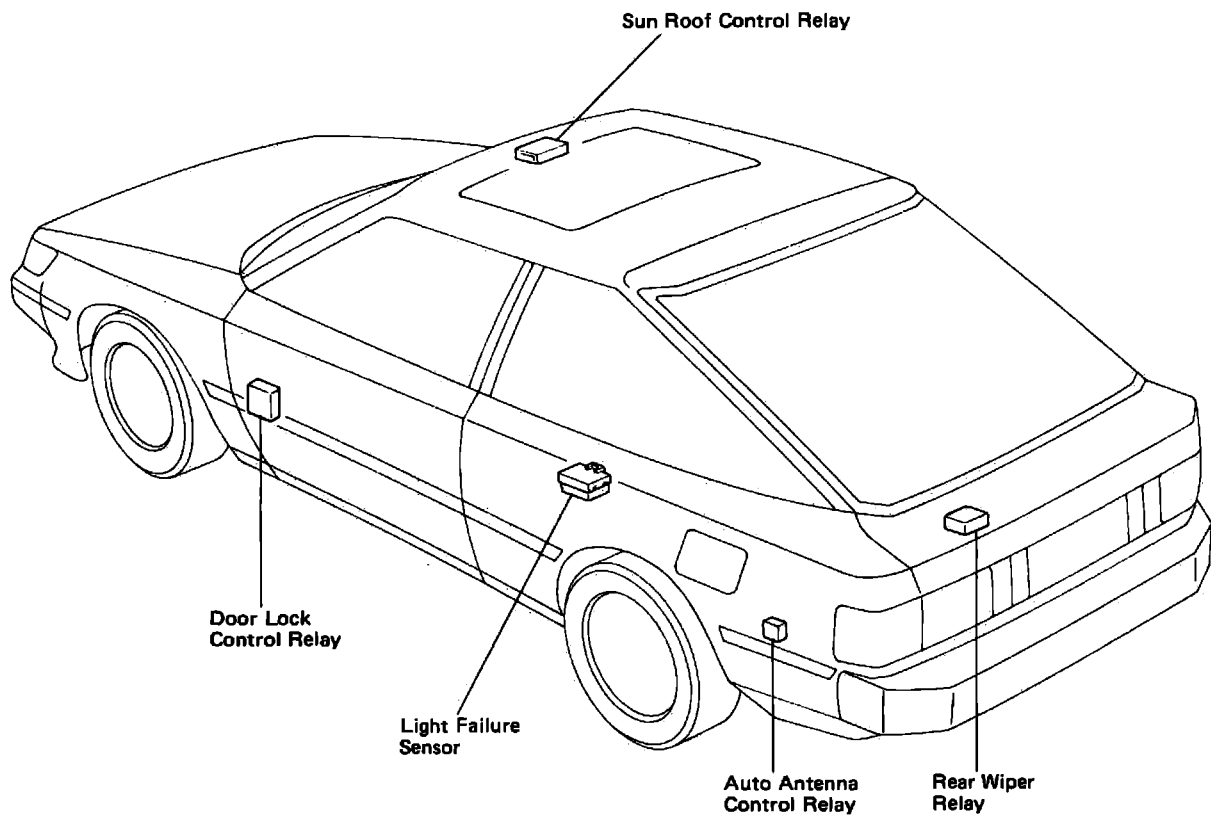
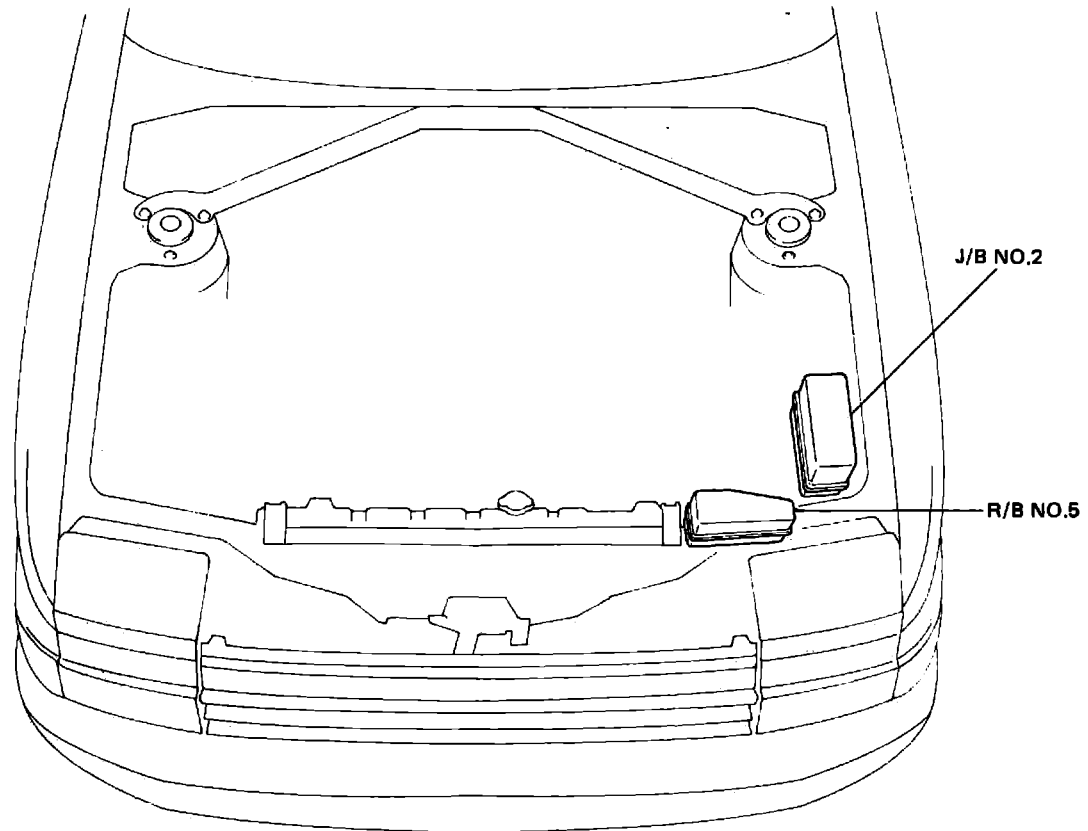

RELAY LOCATIONS

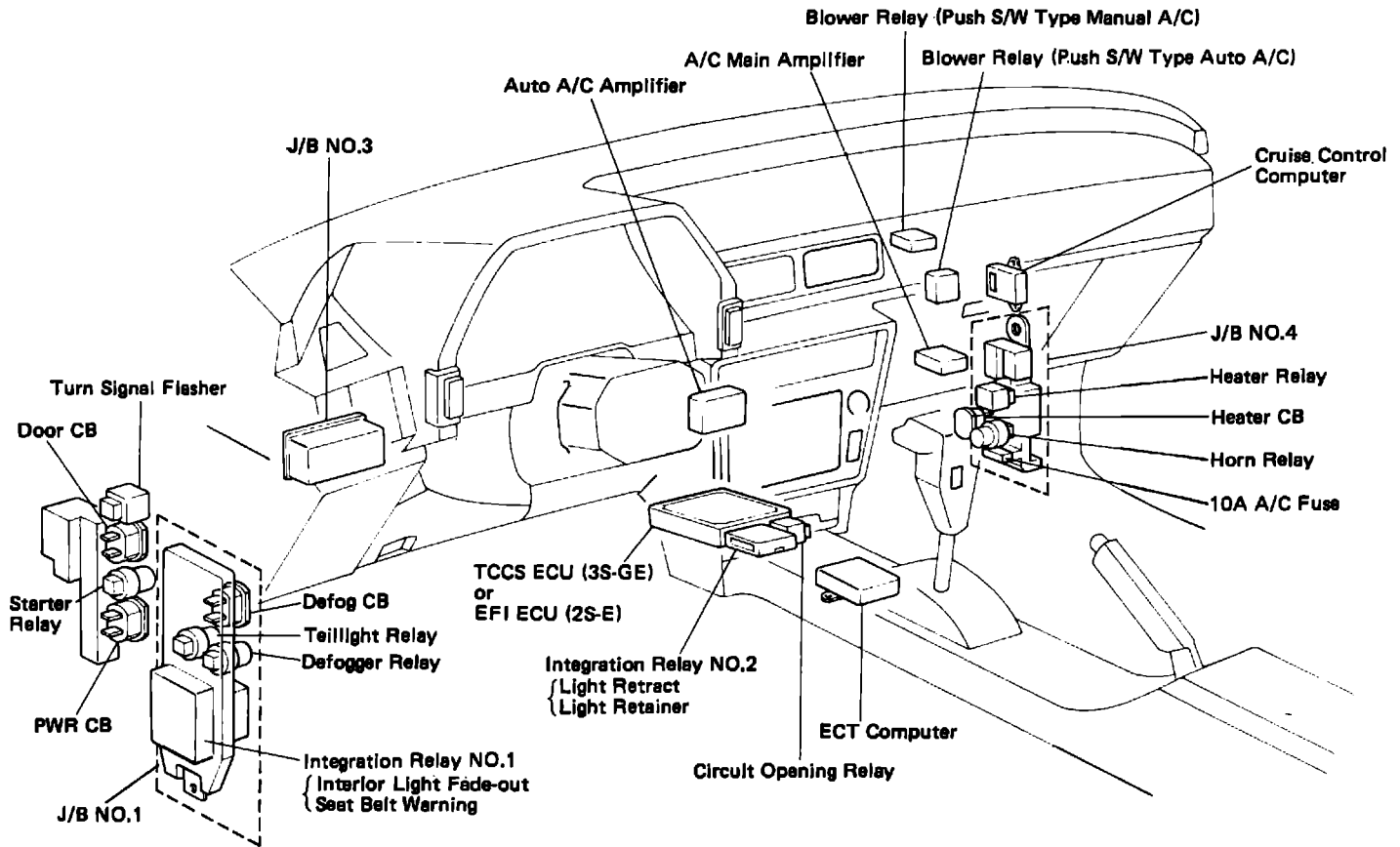

[J/B NO.1]

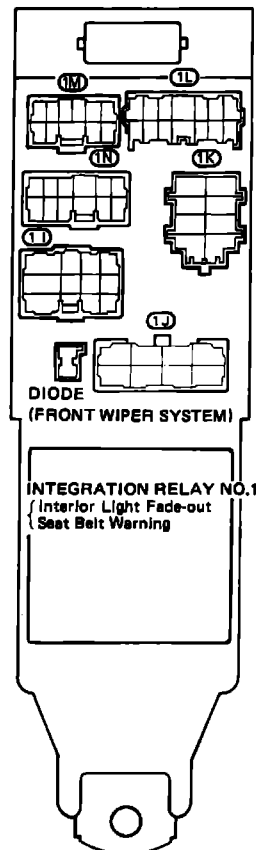
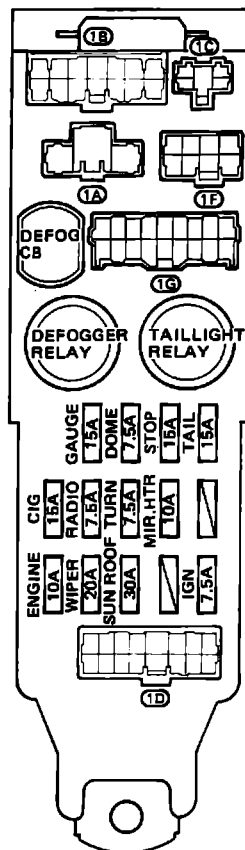

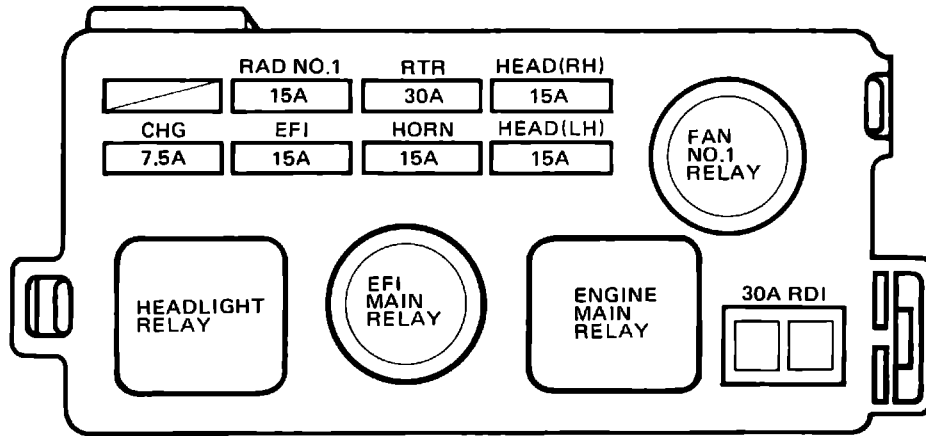

[J/B NO.2]

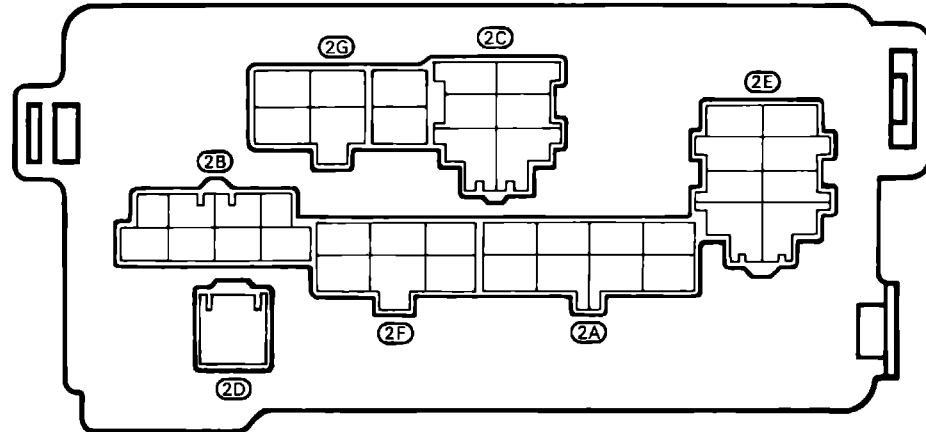

[J/B NO.3]

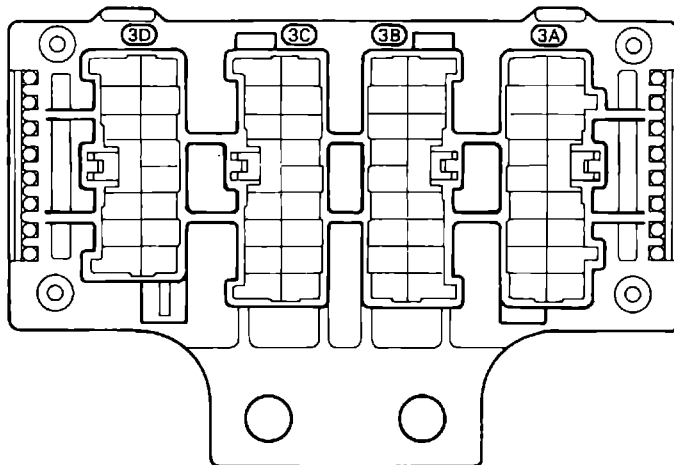

[J/B NO.4]

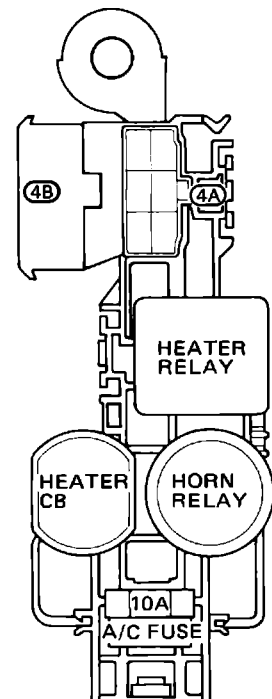

[R/B NO.5]

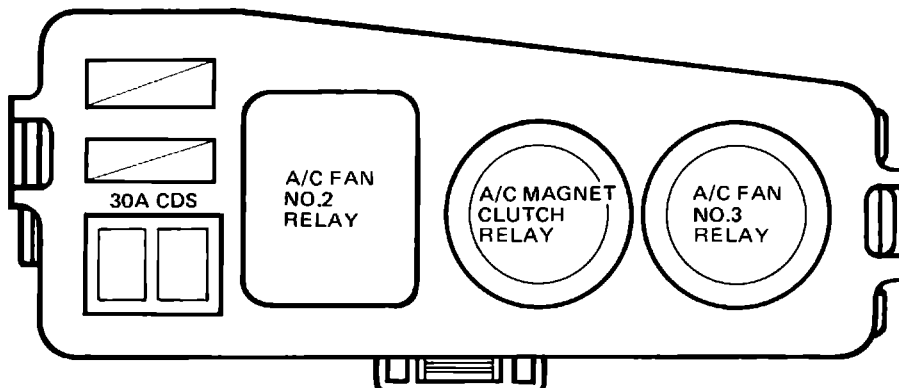

[3S-GE]

[2S-E]

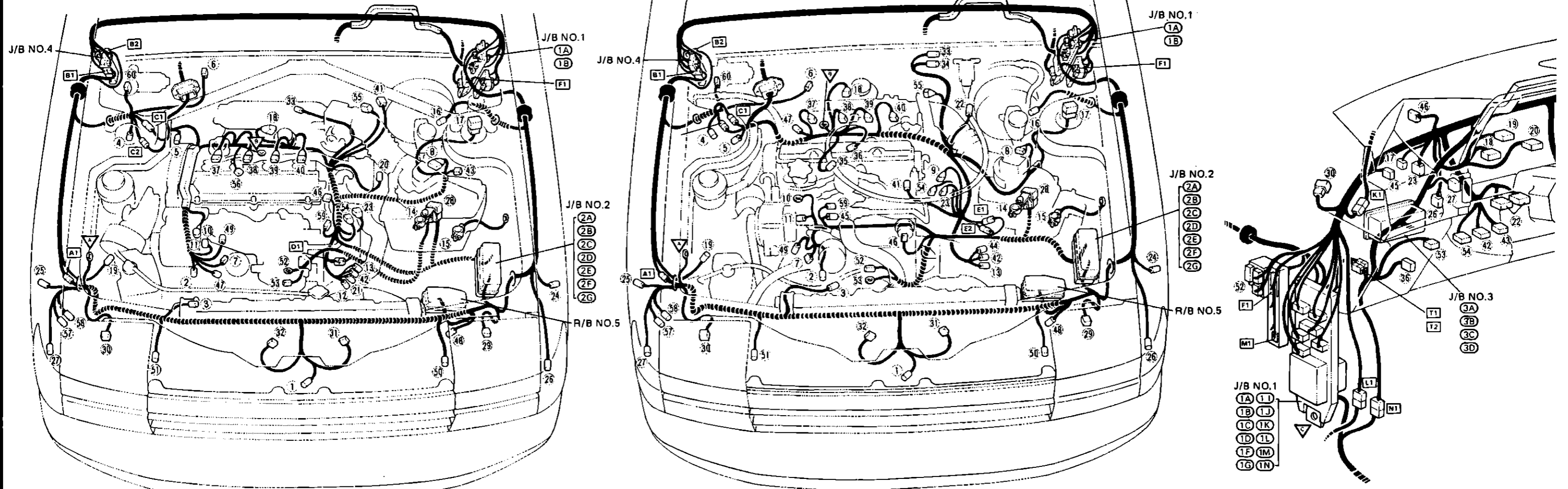

- | | | |
|----------------------------|---|--------------------------------|
| 1 A/C Ambient Sensor | 23 EFI Water Thermo Sensor | 45 O/D Water Temp. S/W (2S-E) |
| 2 A/C Compressor Sensor | 24 Front Side Marker Light LH | 46 Oil Pressure S/W (or Gauge) |
| 3 A/C Condenser Fan Motor | 25 Front Side Marker Light RH | 47 Ox Sensor |
| 4 A/C Dual Pressure S/W | 26 Front Turn Signal and Clearance Light LH | 48 Radiator Fan Motor |
| 5 A/C High Pressure S/W | 27 Front Turn Signal and Clearance Light RH | 49 Radiator Fan Temp. S/W |
| 6 A/C Idle-up VSV | 28 Fusible Link Box | 50 Retract Motor LH |
| 7 A/C Magnet Clutch | 29 Headlight LH | 51 Retract Motor RH |
| 8 Air Flow Meter | 30 Headlight RH | 52 Starter |
| 9 Air Valve (2S-E) | 31 Horn LH | 53 |
| 10 Alternator | 32 Horn RH | 54 Start Injector Time S/W |
| 11 A/T Indicator S/W (ECT) | 33 Igniter | 55 Throttle Position Sensor |
| 12 Back-up Light S/W | 34 | 56 VSV (T-VIS) |
| 13 Battery + Terminal | 35 11A (Distributor and Ignition Coil) | 57 Washer Motor Front |
| 14 Battery - Terminal | 36 | 58 Washer Motor Rear |
| 15 Brake Fluid Level S/W | 37 Injector No. 1 | 59 Water Temp. Sender |
| 16 Check Connector | 38 Injector No. 2 | 60 Wiper Motor |
| 17 Cold Start Injector | 39 Injector No. 3 | |
| 18 Cruise Control Actuator | 40 Injector No. 4 | |
| 19 Distributor | 41 ISC Valve | |
| 20 ECT Solenoid | 42 Neutral Start S/W | |
| 21 EFI Resistor (2S-E) | 43 Noise Filter (Ignition) | |
| | 44 O/D Solenoid (2S-E) | |

- | |
|--|
| 2B Engine Wire and J/B No. 2 (3S-G) |
| 2C Engine No. 2 Wire and J/B No. 2 (2S-E) |
| 2D Engine Room Main Wire and Engine Room No. 2 Wire (Right Front Fender) |
| B1 Engine Room No. 2 Wire and Cowl Wire (Right Kick Panel) |
| B2 Wire (Right Kick Panel) |
| C1 Engine Wire and Engine Room No. 2 Wire (Engine Room Right Rear) |
| D1 Starter Wire and Engine Wire (3S-G, Beside Transmission) |
| E1 Engine No. 4 Wire and Engine Wire (2S-E, Beside Battery) |
| F1 Cowl Wire and Engine Room Main Wire (Left Kick Panel) |
| △ Ground Right Fender |
| ▽ Ground Intake Manifold |

- | | |
|------------------------------|---|
| 1 A/C Air Mix Power Servo | 20 Cruise Control Stop S/W and Stop Light S/W |
| 2 A/C Amplifier | 21 Defogger S/W |
| 3 A/C Auto A/C Amplifier | 22 Diode (Cruise Control) |
| 4 A/C Blower Control Relay | 23 Diode (Electrical Idle-up) |
| 5 A/C Evapo Sensor | 24 Diode (Interior Light) |
| 6 A/C In-car Sensor | 25 ECT Computer |
| 7 A/C Recirc Mode Servo | 26 ECT Pattern Select S/W |
| 8 A/C Solar Sensor | 27 EFI ECU (2S-E) or TCES ECU (3S-G) |
| 9 A/C S/W | 28 Front Speaker LH |
| 10 Blower Motor | 29 Front Speaker RH |
| 11 Blower Resistor | 30 Glove Box Light |
| 12 Cigarette Lighter | 31 Glove Box Light S/W |
| 13 Circuit Opening Relay | 32 Hazard S/W |
| 14 Clock | 33 Heater Blower S/W |
| 15 Clutch Start S/W | 34 Ignition Key Cylinder Light |
| 16 Combination Meter | 35 Ignition S/W |
| 17 Combination S/W | 36 Integration Relay No. 2 |
| 18 Cruise Control Clutch S/W | 37 Noise Filter (Radio) |
| 19 Cruise Control Computer | 38 Noise Filter (Stop Light) |
| 20 Cruise Control Main S/W | 39 O/D S/W and A/T Indicator Light |
| | 40 Parking Brake S/W |
| | 41 Radio and Tape Player |

[L/B]

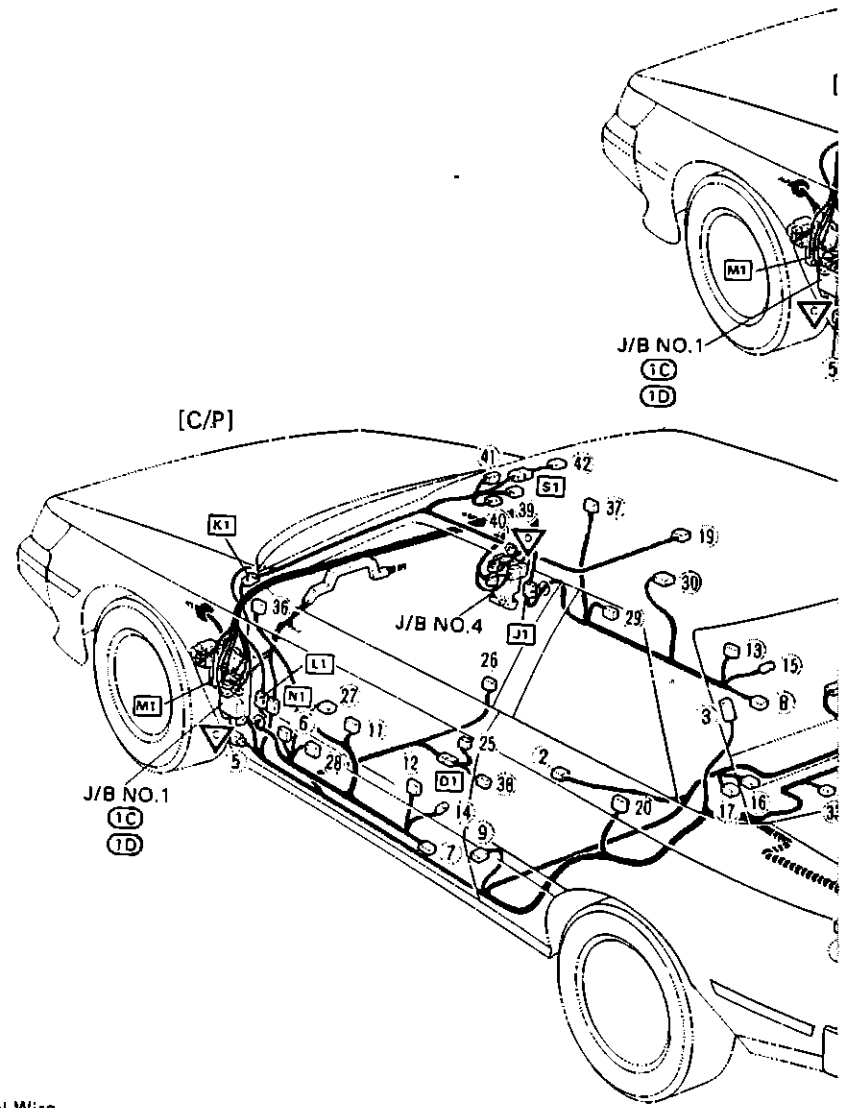
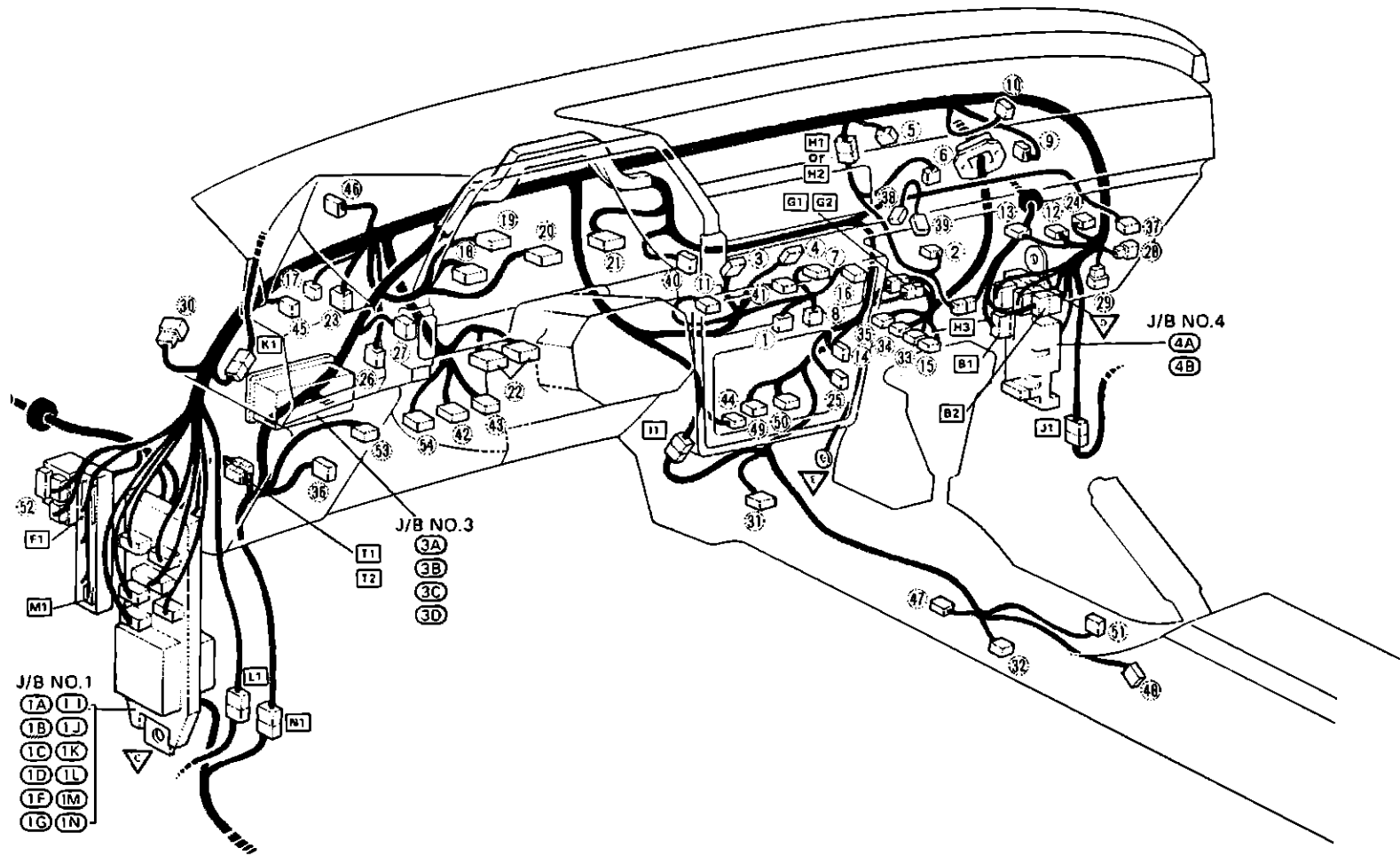

- | | | | | | | | | |
|---------------|----|--|----|--|----|--|---|--------------------------------------|
| Power Servo | 26 | Cruise Control Stop S/W and Stop Light S/W | 51 | Remote Control Mirror S/W | F1 | Engine Room Main Wire and Cowl Wire (Left Kick Panel) | ① | Auto Antenna Control Relay and Motor |
| Amplifier | 27 | Defogger S/W | 52 | R/B No. 1 (Turn Signal Flasher, Door Lock C.B., Starter Relay, PWR C.B.) | G1 | Engine Wire and Instrument Panel Wire (Behind Radio) | ② | Buckle S/W |
| Control Relay | 28 | Diode (Cruise Control) | 53 | Rehostat | G2 | Engine Wire and Instrument Panel Wire (Behind Radio) | ③ | Defogger + |
| Door | 29 | Diode (Electrical Idle-up) | 54 | Unlock Warning S/W | H1 | A/C Wire and Cowl Wire (Instrument Panel Right) | ④ | Defogger - |
| Door | 30 | Diode (Interior Light) | ①A | Engine Room Main Wire and J/B No. 1 | H2 | Engine Room No. 2 Wire and A/C Wire (Instrument Panel Right) | ⑤ | Diode (Interior Light) |
| Door | 31 | ECT Computer | ①B | Room Wire and J/B No. 1 | I1 | Instrument Panel Wire and Cowl Wire (Behind Radio) | ⑥ | Door Control Relay |
| Door | 32 | ECT Pattern Select S/W | ①C | Floor Wire and J/B No. 1 | J1 | Front Door RH Wire and Cowl Wire (Right Kick Panel) | ⑦ | Door Courtesy Light LH |
| Door | 33 | ECT ECU (2S-E) or TCCS ECU (3S-G) | ①D | Instrument Panel Wire and J/B No. 1 | K1 | Roof Wire and Cowl Wire (Left Kick Panel) | ⑧ | Door Courtesy Light RH |
| Door | 34 | Front Speaker LH | ①E | Cowl Wire and J/B No. 1 | L1 | Front Door LH Wire and Cowl Wire (Left Kick Panel) | ⑨ | Door Courtesy S/W LH |
| Door | 35 | Front Speaker RH | ①F | Cowl Wire and J/B No. 1 | M1 | Floor Wire and Cowl Wire (J/B No. 1, Left Kick Panel) | ⑩ | Door Courtesy S/W RH |
| Door | 36 | Glove Box Light | ①G | Cowl Wire and J/B No. 1 | N1 | Floor Wire and Instrument Wire (Left Kick Panel) | ⑪ | Door Lock Control S/W |
| Door | 37 | Glove Box Light S/W | ①H | Cowl Wire and J/B No. 1 | T1 | Instrument Panel Wire and Instrument Panel | ⑫ | Door Lock Unlock S/W LH |
| Door | 38 | Hazard S/W | ①I | Cowl Wire and J/B No. 1 | T2 | Sub Wire (Instrument Panel Left) | ⑬ | Door Lock Unlock S/W RH |
| Door | 39 | Heater Blower S/W | ①J | Cowl Wire and J/B No. 1 | △ | Ground J/B No. 1 Set Bolt | ⑭ | Door Lock Solenoid LH |
| Door | 40 | Ignition Key Cylinder Light | ①K | Cowl Wire and J/B No. 1 | ▽ | Ground J/B No. 4 Set Bolt | ⑮ | Door Lock Solenoid RH |
| Door | 41 | Ignition S/W | ①L | Cowl Wire and J/B No. 1 | ▽ | Ground Behind Radio | ⑯ | Fuel Sender |
| Door | 42 | Integration Relay No. 2 | ①M | Cowl Wire and J/B No. 1 | | | ⑰ | Fuel Pump |
| Door | 43 | Noise Filter (Radio) | ①N | Cowl Wire and J/B No. 1 | | | ⑱ | High Mount Stop Light |
| Door | 44 | Noise Filter (Stop Light) | ③A | Instrument Panel Wire and J/B No. 3 | | | ⑲ | Interior Light |
| Door | 45 | O/D S/W and A/T Indicator Light | ③B | Instrument Panel Wire and J/B No. 3 | | | ⑳ | Light Failure Sensor |
| Door | 46 | Parking Brake S/W | ③C | Instrument Panel Wire and J/B No. 3 | | | ㉑ | Lisence Light LH |
| Door | 47 | Radio and Tape Player | ③D | Instrument Panel Wire and J/B No. 3 | | | ㉒ | Lisence Light RH |
| Door | 48 | Radio and Tape Player | ④A | Cowl Wire and J/B No. 4 | | | | |
| Door | 49 | Radio and Tape Player | ④B | Cowl Wire and J/B No. 4 | | | | |
| Door | 50 | Radio and Tape Player | B1 | Engine Room No. 2 Wire and Cowl Wire (Right Kick Panel) | | | | |
| Door | | | B2 | Engine Room No. 2 Wire and Cowl Wire (Right Kick Panel) | | | | |

[L/B]

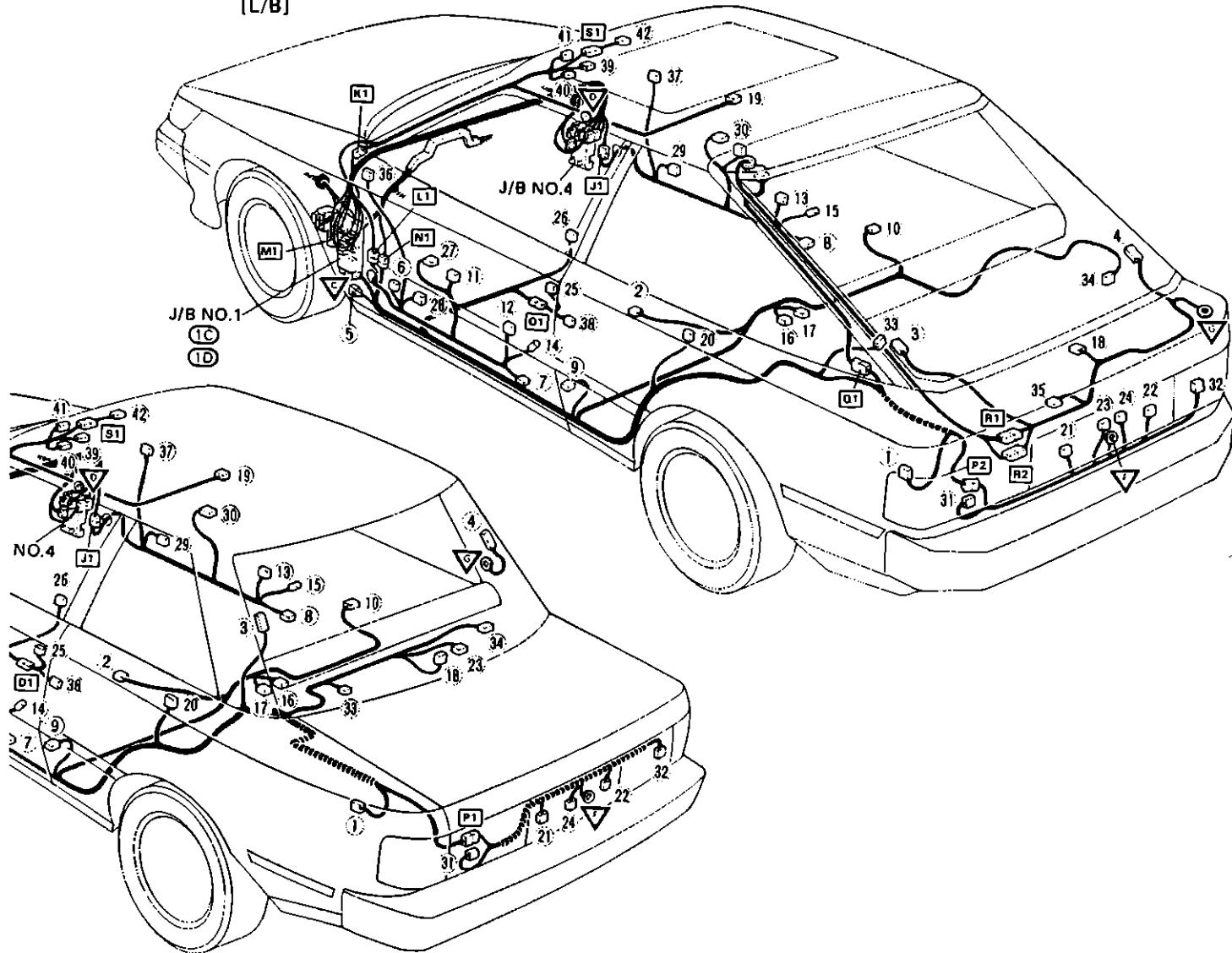

- o Antenna Control Relay and Motor
- o Brake S/W
- o Fogger +
- o Fogger -
- o Dome (Interior Light)
- o Control Relay
- o Courtesy Light LH
- o Courtesy Light RH
- o Courtesy S/W LH
- o Courtesy S/W RH
- o Lock Control S/W
- o Lock Unlock S/W LH
- o Lock Unlock S/W RH
- o Lock Solenoid LH
- o Lock Solenoid RH
- o Fuel Sender
- o Fuel Pump
- o Horn Mount Stop Light
- o Rear Light
- o Light Failure Sensor
- o License Light LH
- o License Light RH



























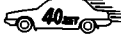





- 23 Luggage Compartment Light
- 24 Luggage Compartment Light S/W
- 25 Lumber Support Motor
- 26 Power Seat S/W
- 27 Power Window Master S/W
- 28 Power Window Motor LH
- 29 Power Window Motor RH
- 30 Power Window S/W RH
- 31 Rear Combination Light LH
- 32 Rear Combination Light RH
- 33 Rear Speaker LH
- 34 Rear Speaker RH
- 35 Rear Wiper Motor
- 36 Remote Control Mirror LH
- 37 Remote Control Mirror RH
- 38 Side Support Motor
- 39 Sun Roof Control Relay
- 40 Sun Roof Limit S/W
- 41 Sun Roof Motor S/W
- 42 Sun Roof S/W
- (1C) Roof Wire and J/B No. 1
- (1D) Floor Wire and J/B No. 1

- (J1) Front Door RH Wire and Cowl Wire (Right Kick Panel)
- (K1) Roof Wire and Cowl Wire (Left Kick Panel)
- (L1) Front Door LH Wire and Cowl Wire (Left Kick Panel)
- (M1) Floor Wire and Cowl Wire (R/B No. 1, Left Kick Panel)
- (N1) Floor Wire and Instrument Panel Wire (Left Kick Panel)
- (O1) Seat Wire and Floor Wire (Under Front LH Seat)
- (P1) Luggage Room Wire and Floor Wire (Back Panel Left)
- (P2) (Back Panel Left)
- (Q1) Back Door No. 1 Wire and Floor Wire (L/B, Under Left Rear Pillar)
- (R1) Back Door No. 2 Wire and Back Door No. 1 Wire (L/B, Back Door Left)
- (R2) Wire (L/B, Back Door Left)
- (S1) Roof No. 2 Wire and Roof Wire (Roof Front)
- ▽ Ground J/B No. 1 Set Bolt
- ▽ Ground J/B No. 4 Set Bolt
- ▽ Ground Back Panel Center
- ▽ Ground Back Door Right (L/B) Ground Right Rear Pillar (C/P)

SYSTEM INDEX

CELICA

1986 Model (Page 1 to Page 7)

SYSTEMS	LOCATION	SYSTEMS	LOCATION
Air Conditioner, Cooler and Heater	 2-5, 3-5	Power Seats	 6-7
Auto Antenna	 7-4	Power Source	 1-1
Automatic Transmission Indicator	 4-7	Power Windows	 6-6
Back-up Lights	 4-8	Radiator Fan	 2-4
Charging	 2-3	Radio and Tape Player	 7-5
Cigarette Lighter	 7-3	Rear Window Defogger	 4-5
Clock	 7-3	Rear Wiper and Washer	 2-8
Combination Meter	 4-2	Remote Control Mirrors with Heater	 7-6
Cruise Control	 5-1	Starting	 1-1
Door Locks	 7-2	Stop Lights	 5-2
ECT (Electronic Control Transmission)	 4-6	Sun Roof	 6-8
EFI	 1-5	Taillights and Illumination	 5-4
Front Wiper and Washer	 2-7	Turn Signal and Hazard	 6-4
Headlights	 5-7	Unlock and Seat Belt Warning	 6-1
Horn	 6-5	Idle-up	 1-8
Ignition	 2-1		
Interior Lights	 6-2		
Overdrive	 4-5		

CELICA ELECTRICAL WIRING DIAGRAM-1986 Model (Page 1 to Page 7)

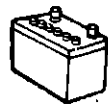

Power Source

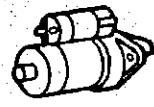

Starting

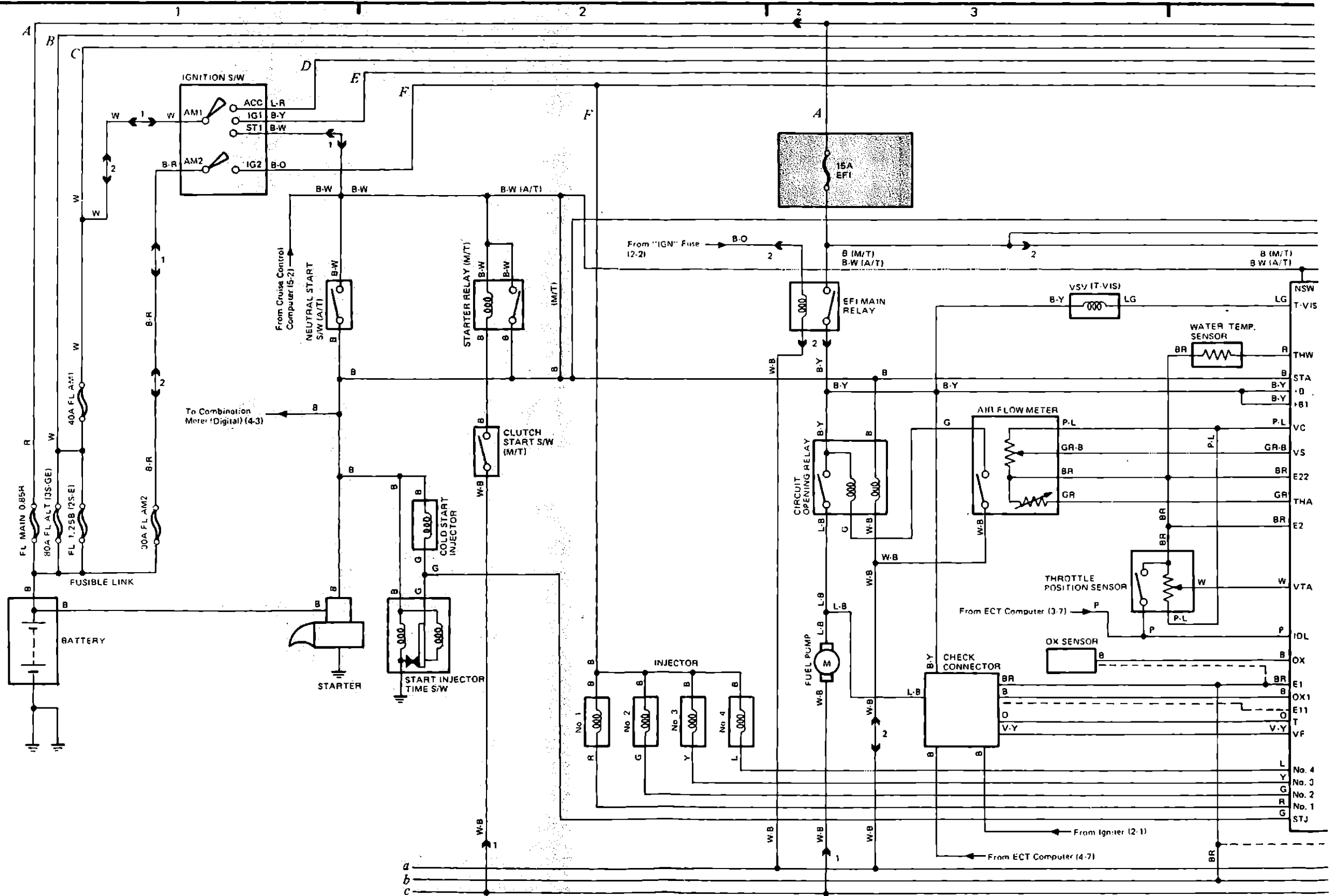

Ground points

a - Located on right front fender

b - Located on engine block

c - Located under left front pillar in junction block No. 1

IG DIAGRAM-1986 Model (Page 1 to Page 7)

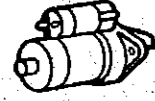

Starting



EFI

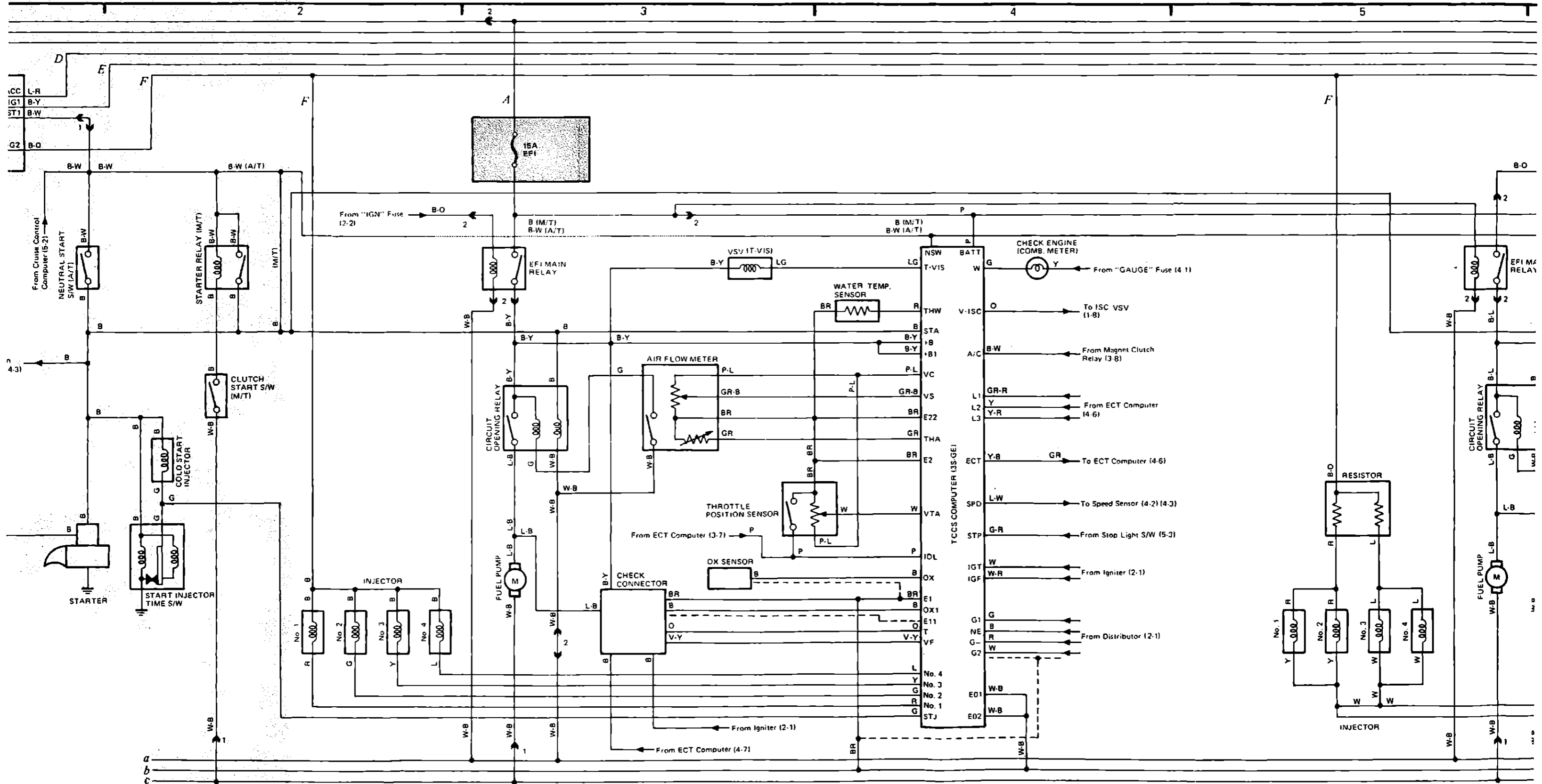

b = Located on engine block

c = Located under left front pillar in junction block No. 1



EFI

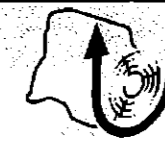

Idle-up

5

6

7

8

A
B
C
D
E
F

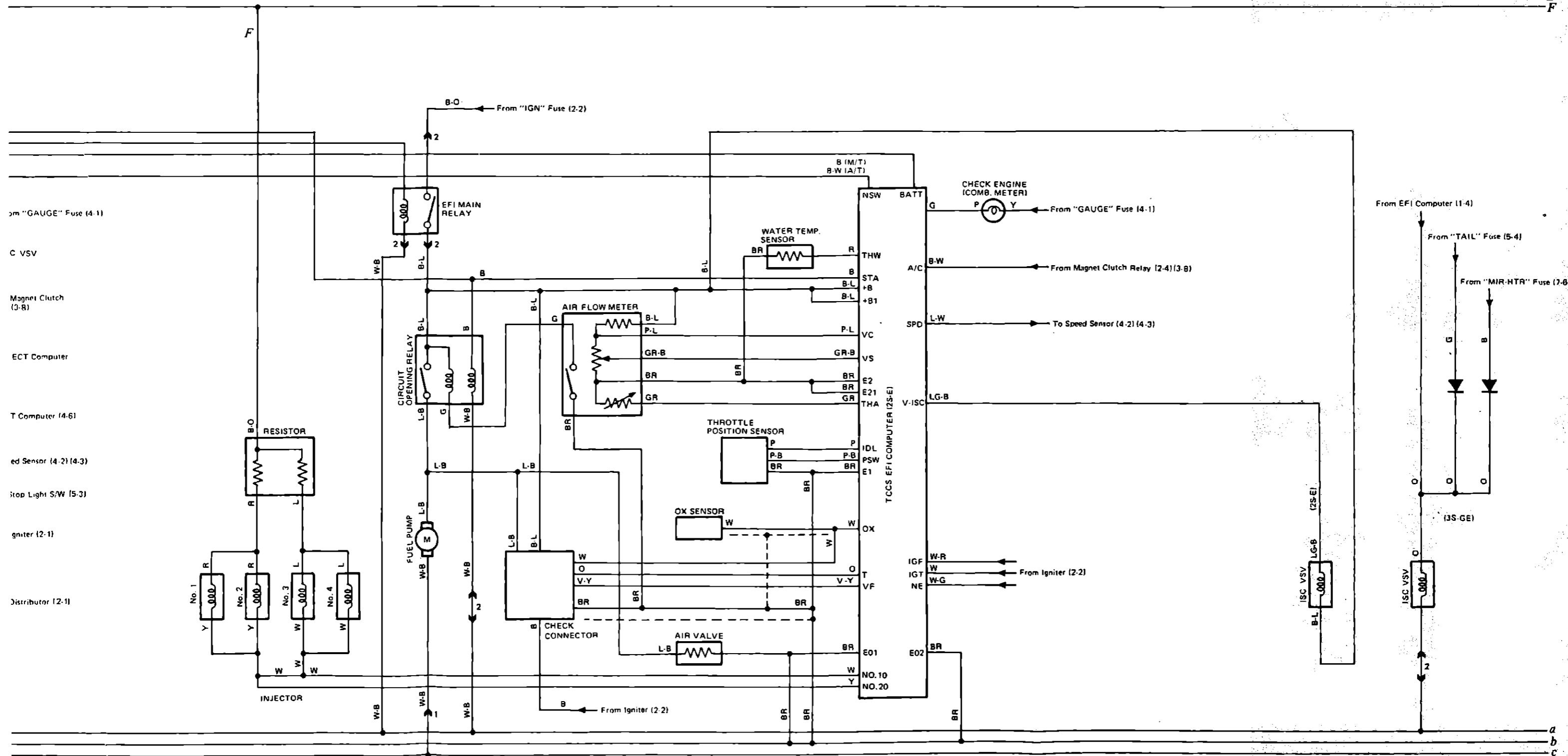

From "GAUGE" Fuse (4-1)

C VSV

Magnet Clutch (3-8)

ECT Computer

T Computer (4:6)

ed Sensor (4:2)(4:3)

Stop Light S/W (5:3)

Igniter (2:1)

Distributor (2:1)

From EFI Computer (1-4)

From "TAIL" Fuse (5-4)

From "MIR-HTR" Fuse (7-8)

(3S-GE)

ISC VSV (2S-E)

ISC VSV (2S-E)

a
b
c

2 CELICA (Cont'd)

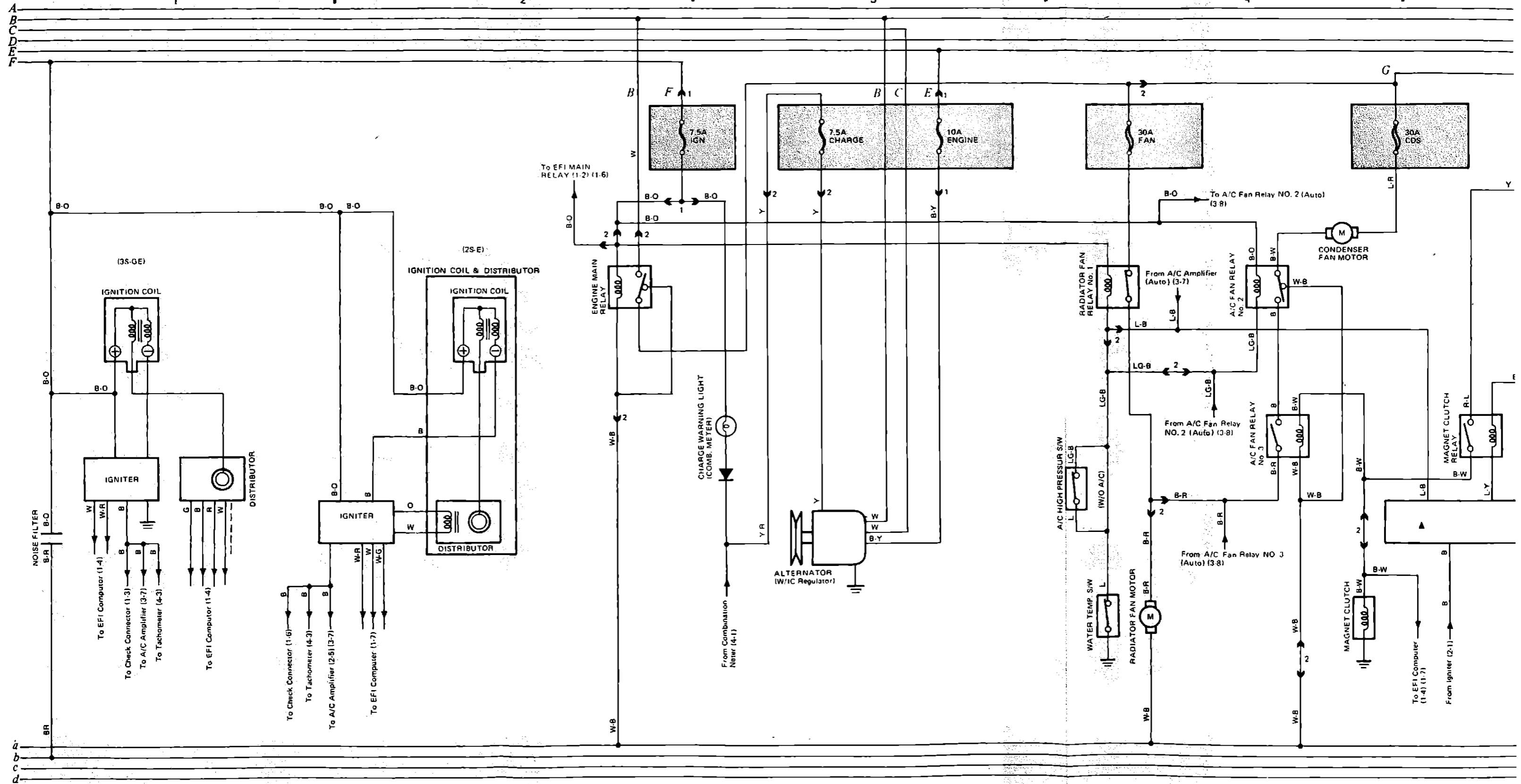
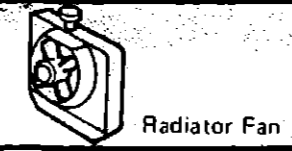

Ground points

a - Located on right front fender

b - Located on engine block

c - Located under left front pillar in junction block No. 1

d - Located under left front pillar in junction block No. 4

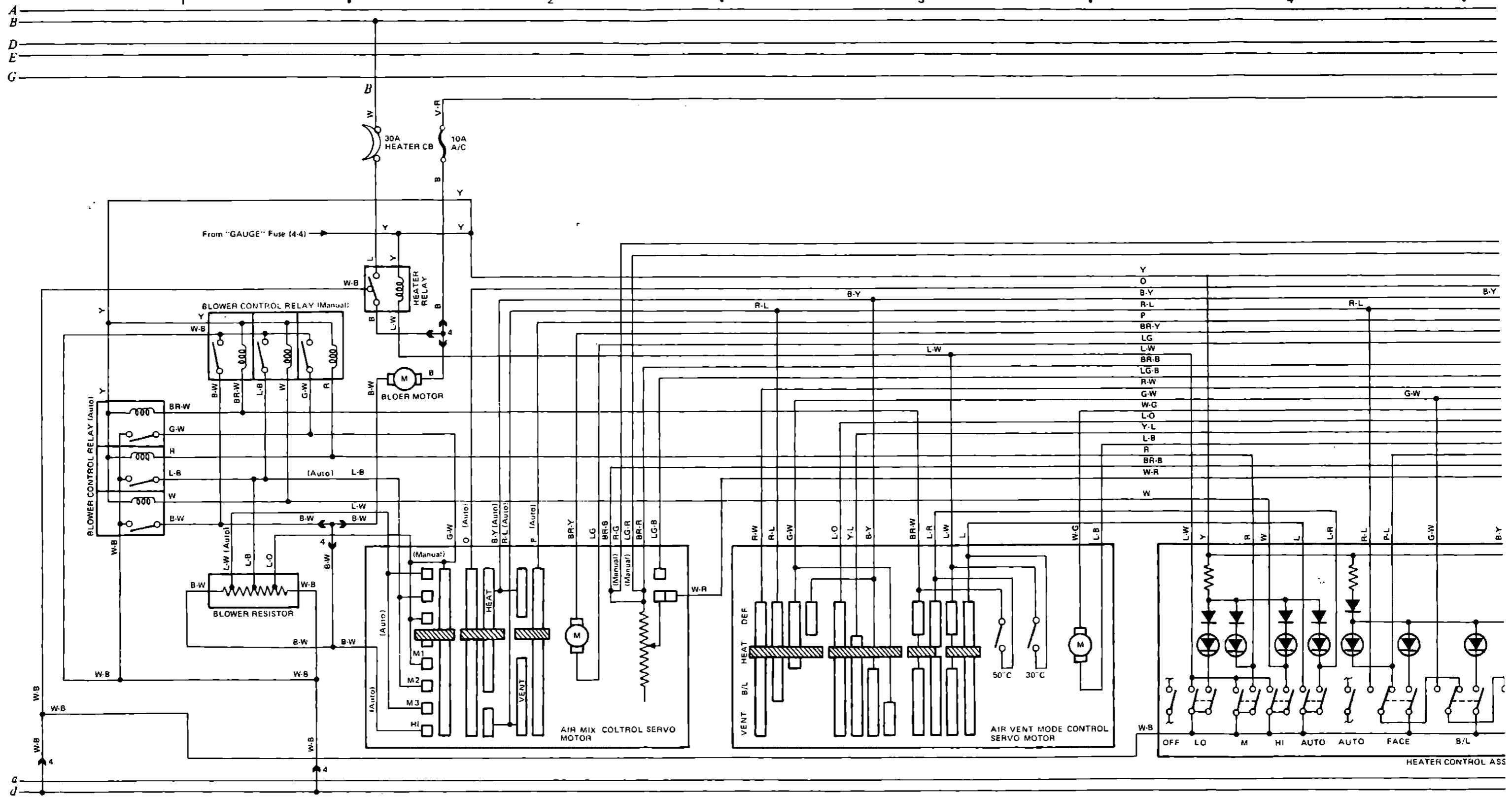

Ground points

a - Located on right front fender

d - Located under left front pillar in junction block No. 4

h Type)

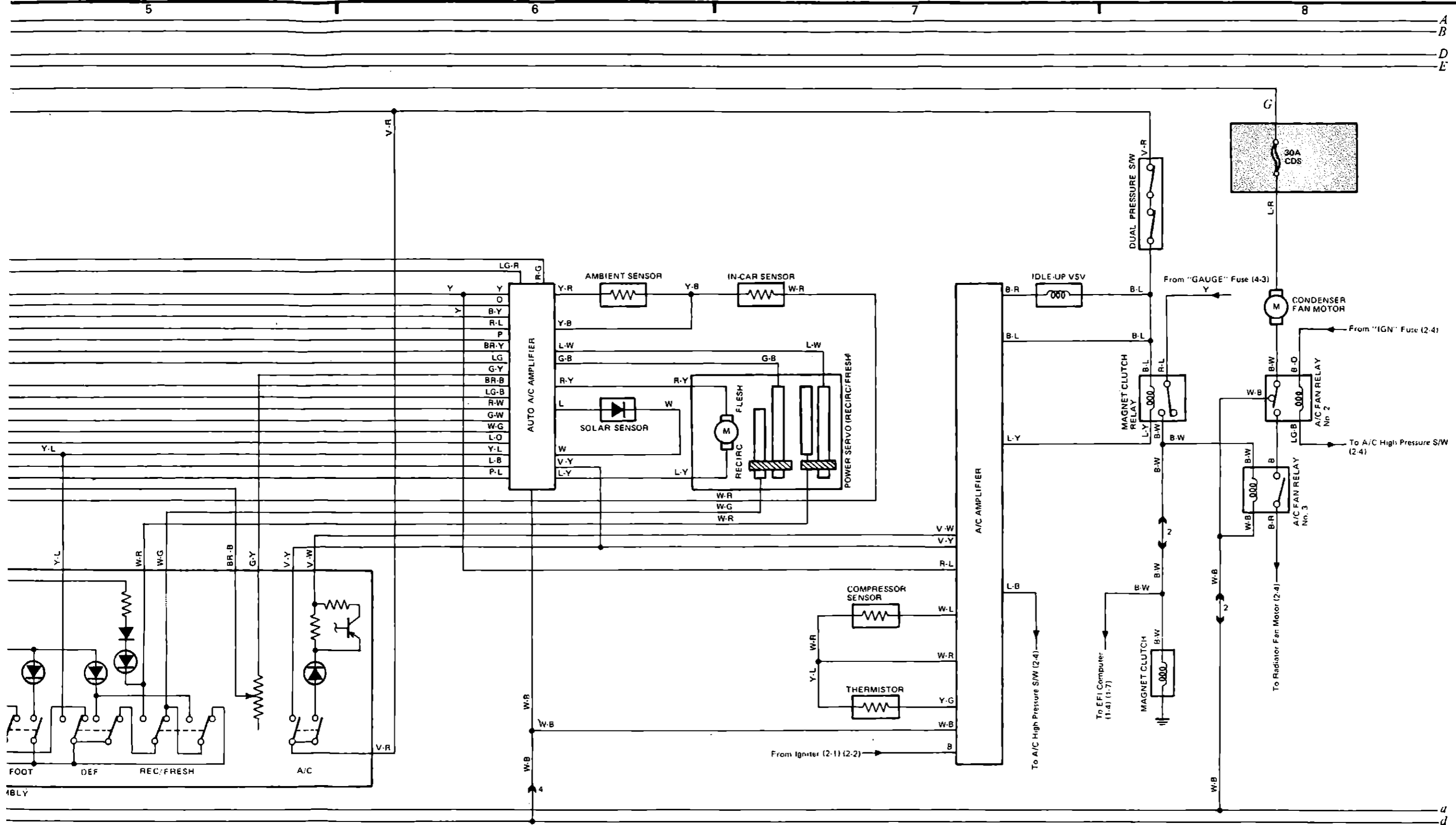

4 CELICA (Cont'd)



Combination Meter

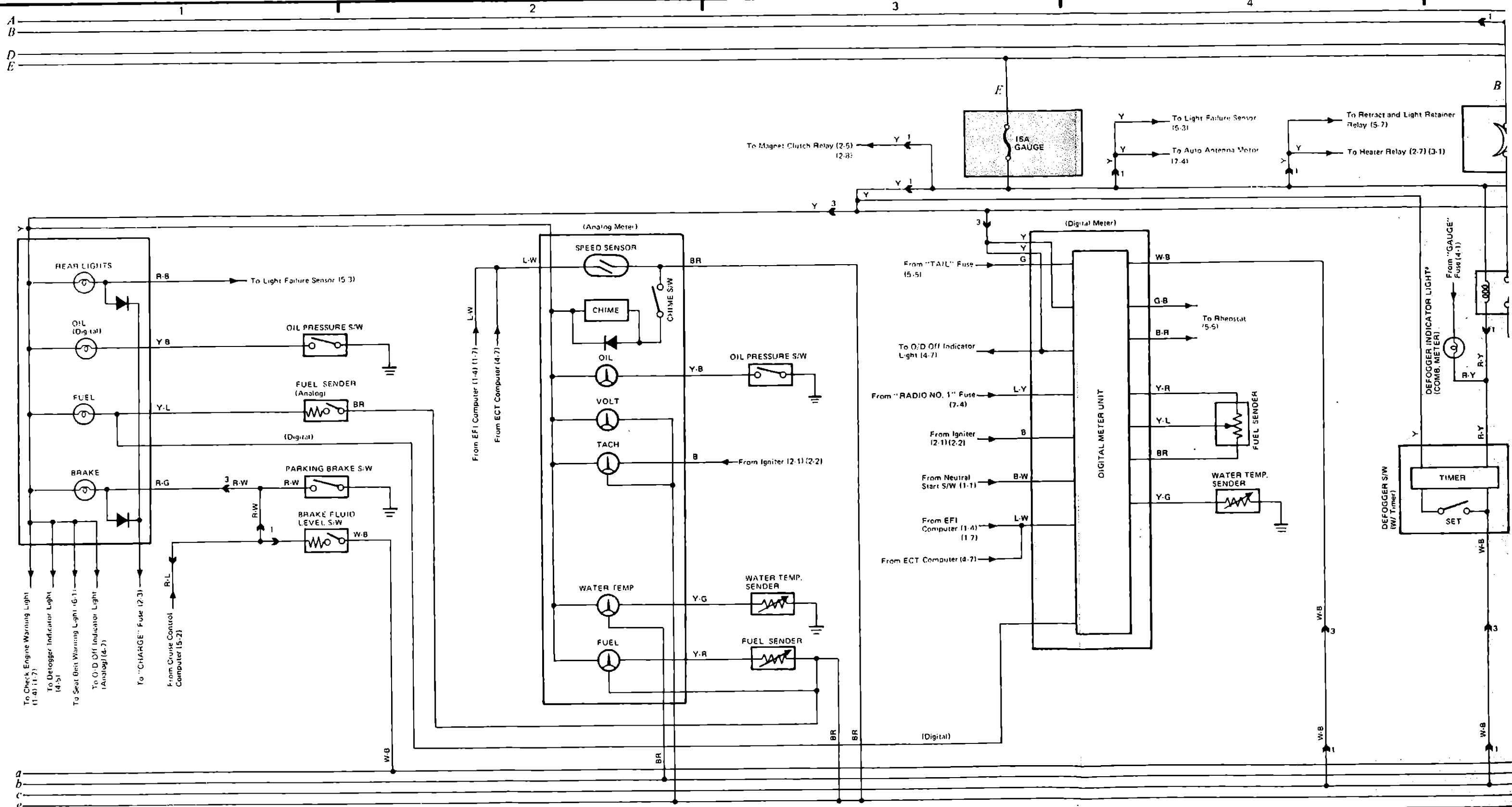

Ground points

a - Located on right front fender

b - Located on engine block

c - Located under left front pillar in junction block No. 1

e - Located in left side of instrument panel (LHD)

f - Located on center of back panel



Rear Window Defogger



Overdrive



(Electronic Controlled Transmission)



Automatic Transmission Indicator



Back-up Lights

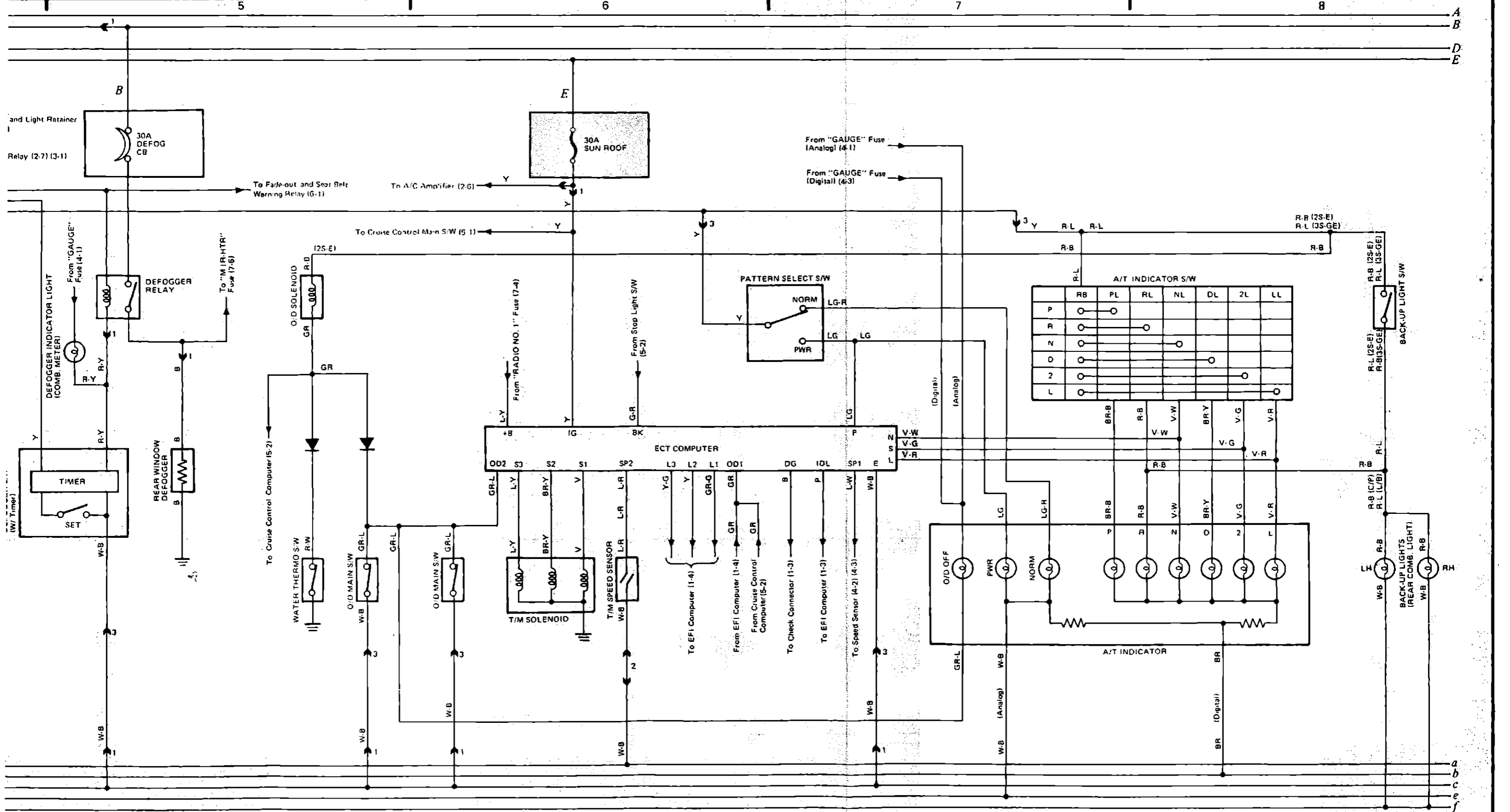

CELICA (Cont'd)



Cruise Control



Stop Lights



Taillights

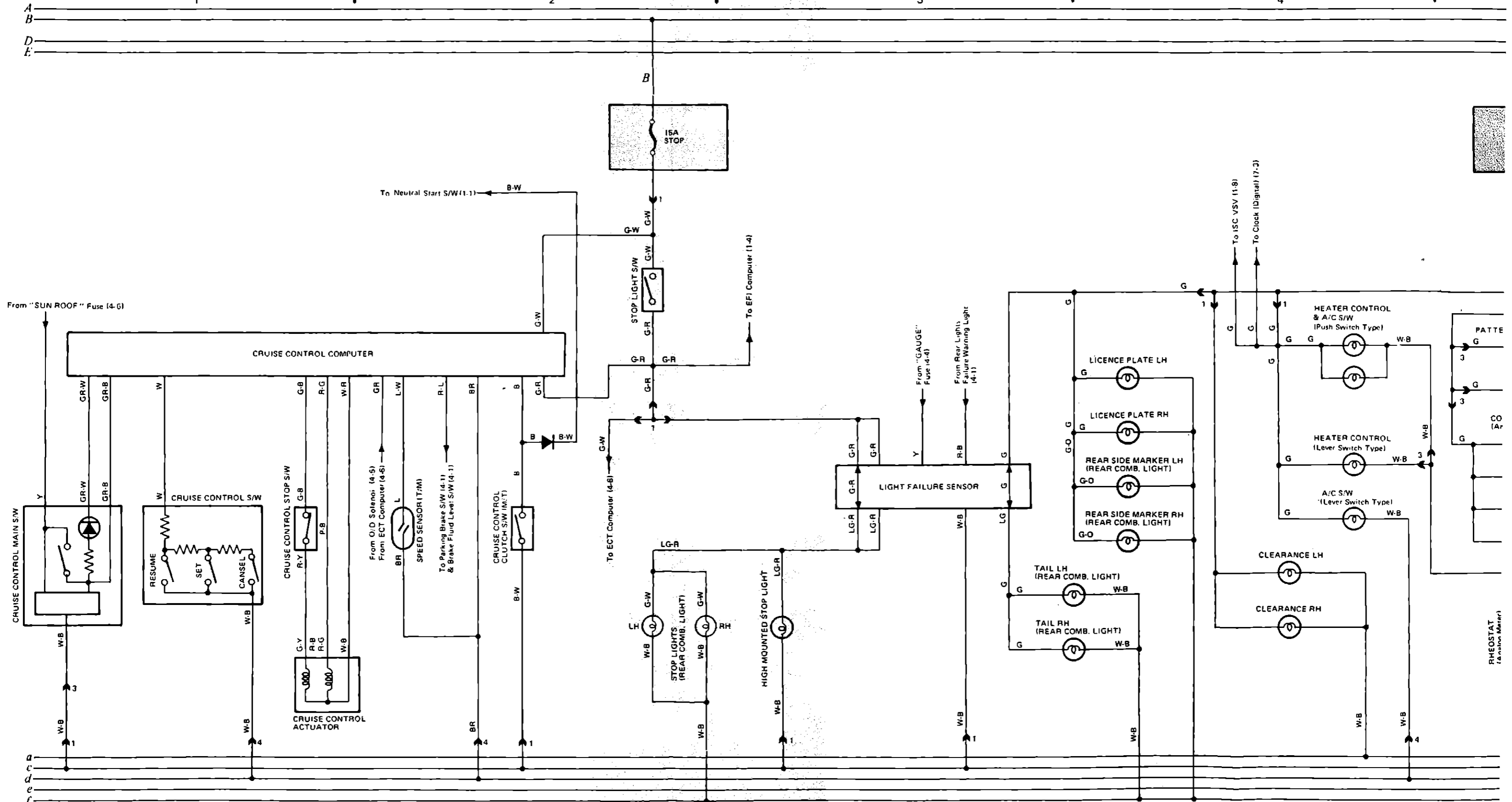

Ground points

a - Located on right front fender

b - Located under left front pillar in junction block No. 1

c - Located under left front pillar in junction block No. 4

d - Located in left side of instrument panel

e - Located on center of back panel

6 CELICA (Cont'd)



Unlock and Seat Belt Warning

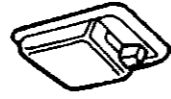

Interior Lights

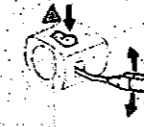

Turn Signal and Hazard

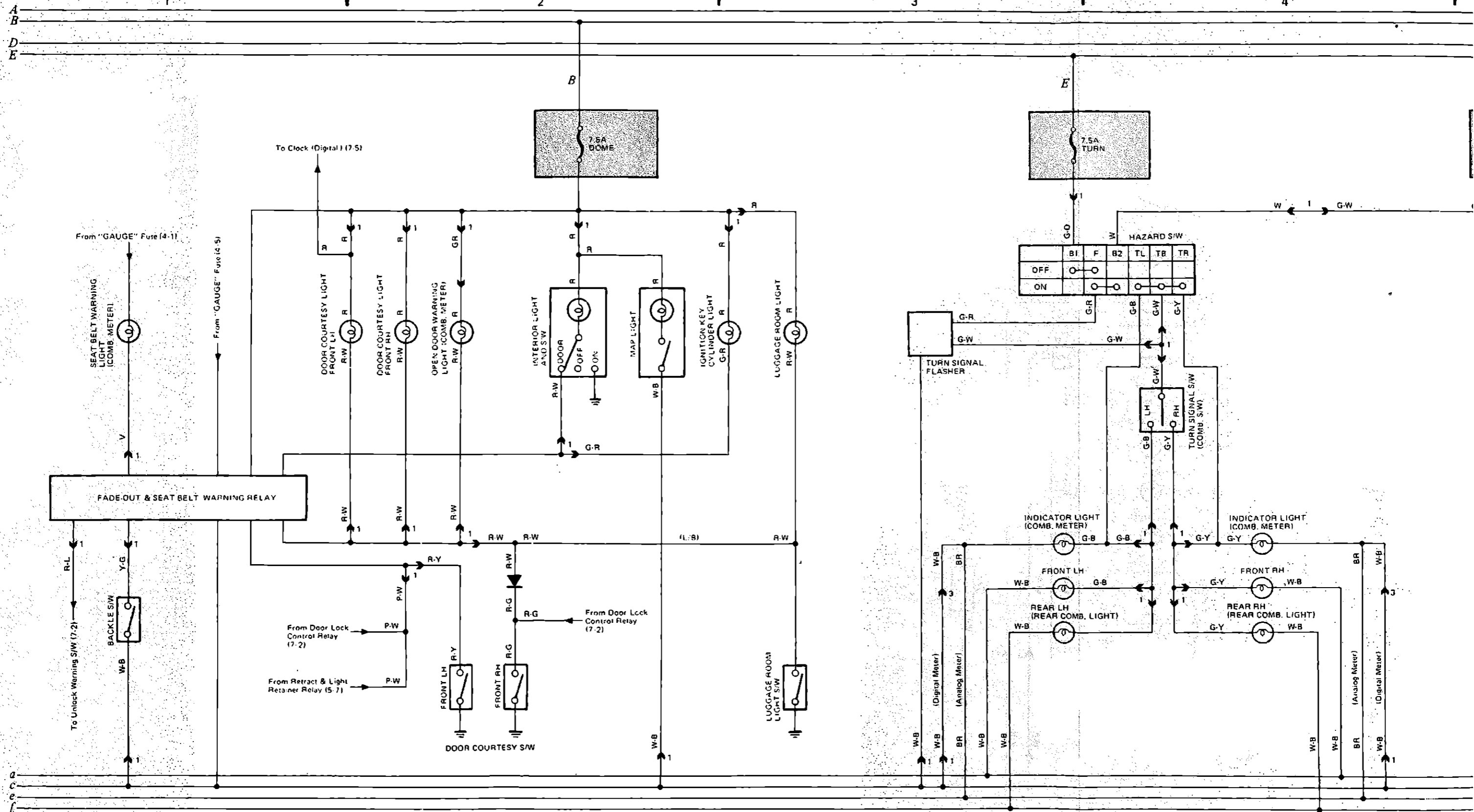

	B1	F	B2	TL	TB	TR
OFF	<input type="checkbox"/>	<input type="checkbox"/>	<input type="checkbox"/>	<input type="checkbox"/>	<input type="checkbox"/>	<input type="checkbox"/>
ON	<input type="checkbox"/>	<input type="checkbox"/>	<input type="checkbox"/>	<input type="checkbox"/>	<input type="checkbox"/>	<input type="checkbox"/>

Ground points: *g* - Located on right front fender *c* - Located under left front pillar in junction block No. 1 *e* - Located in left side of instrument panel *f* - Located on center of back panel



Horn

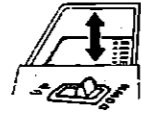

Power Windows



Power Seats



Sun Roof

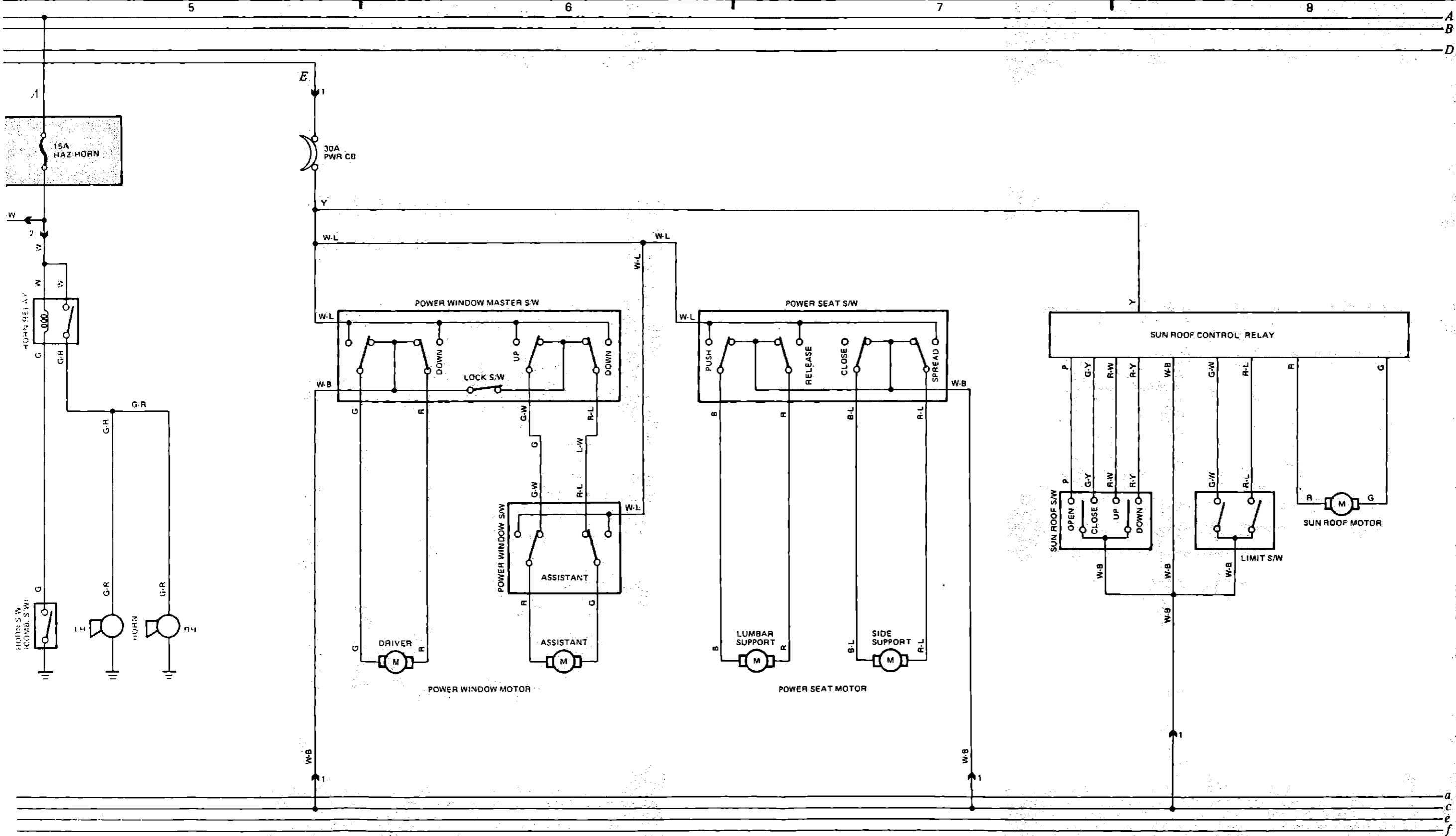

CELICA (Cont'd)



Door Locks



Clock



Cigarette Lighter



Auto Antenna

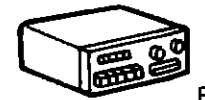

Radio

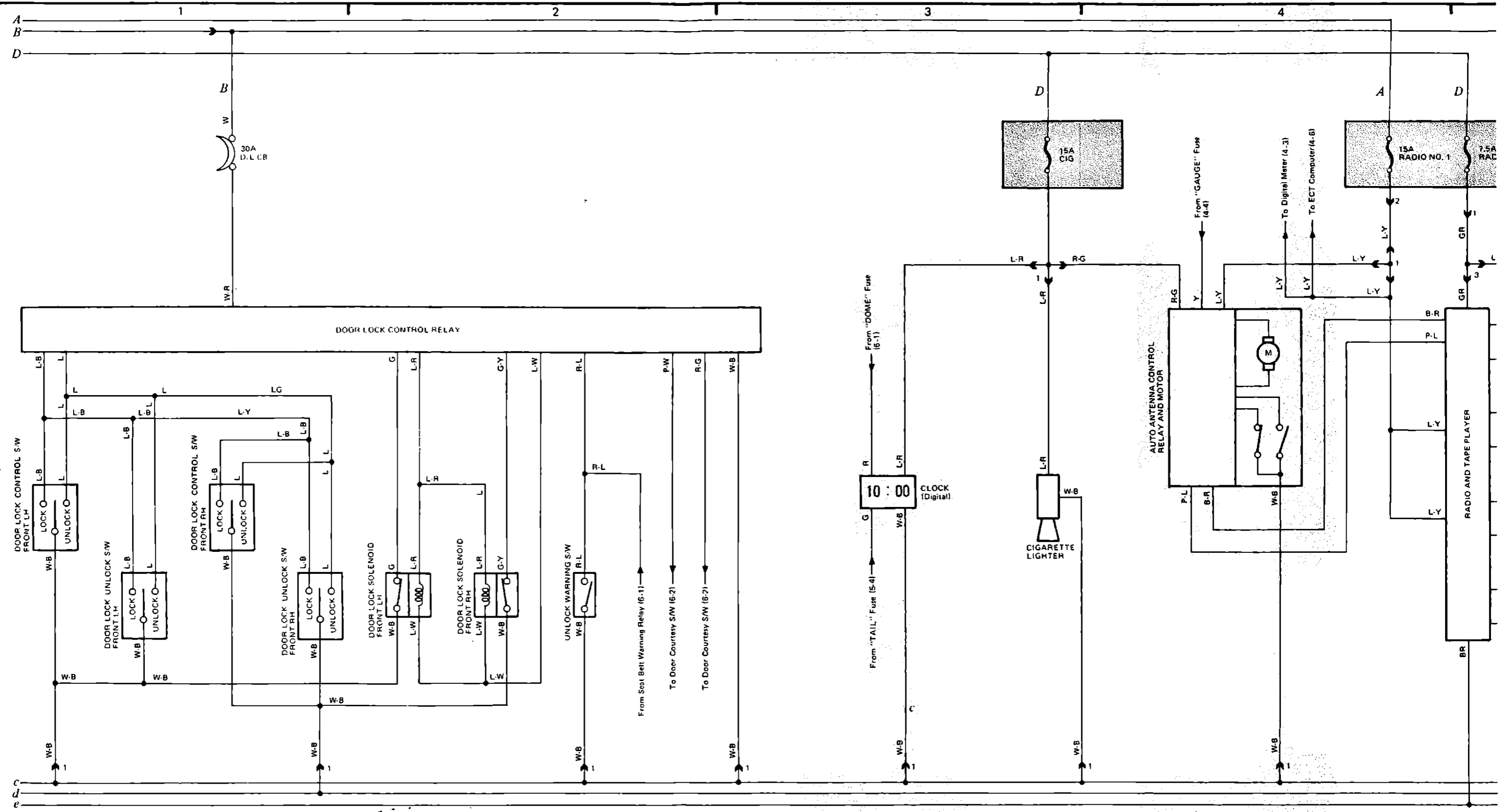

Ground points

c = Located under left front pillar in junction block No. 1

d = Located under left front pillar in junction block No. 4

e = Located in left side of instrument panel

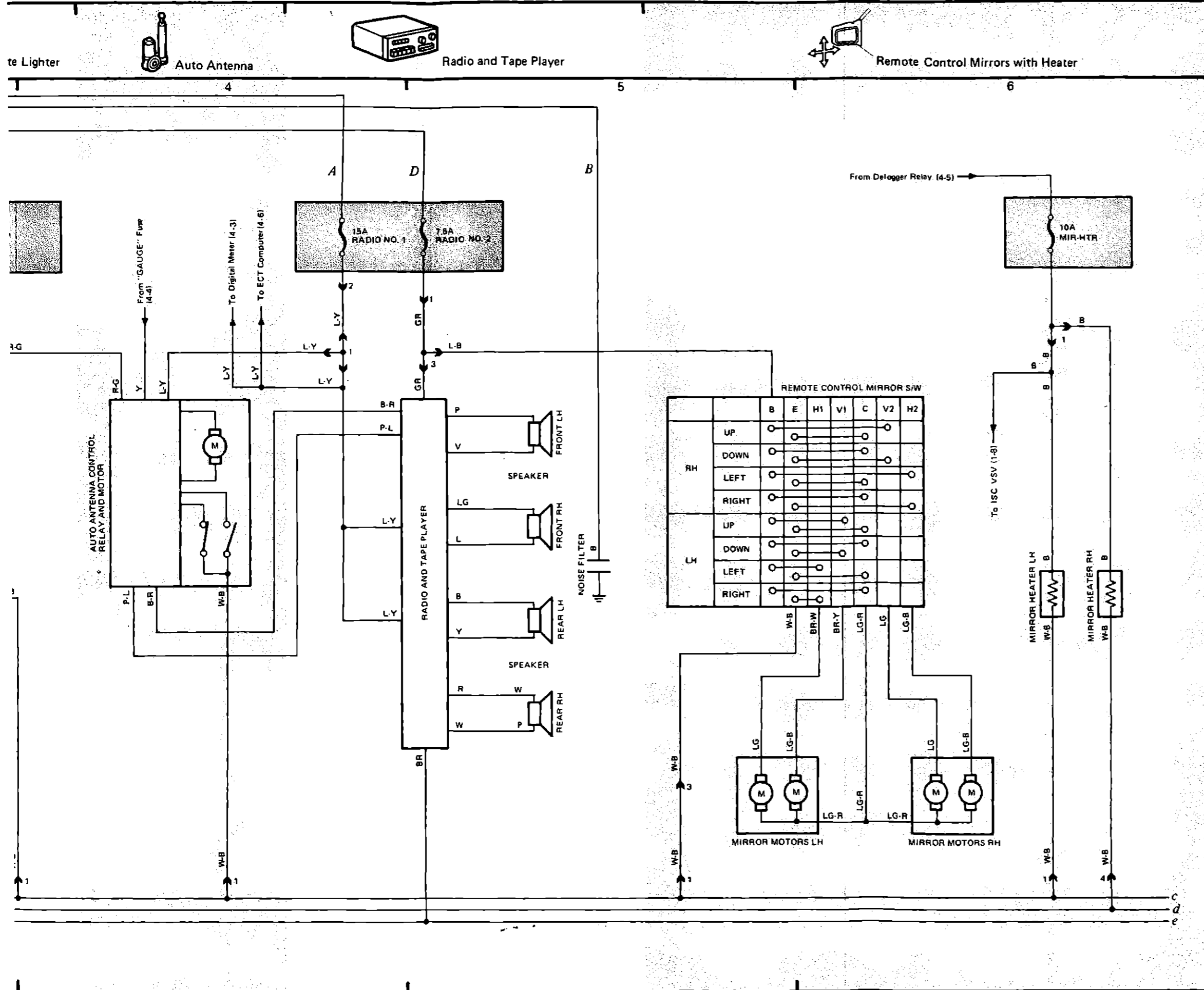

REMOTE CONTROL MIRROR S/W

	B	E	H1	V1	C	V2	H2
RH	UP	○	○	○	○	○	
	DOWN	○	○	○	○	○	
	LEFT	○	○	○	○	○	
LH	RIGHT	○	○	○	○	○	
	UP	○	○	○	○	○	
	DOWN	○	○	○	○	○	
	LEFT	○	○	○	○	○	
	RIGHT	○	○	○	○	○	

TOYOTA
QUALITY SERVICE