



Neighborhood News

LAKE FOREST ESTATES HOMEOWNERS' ASSOCIATION, November 2019

Inside This Issue

President's Message	1
Bulletin Board	2
Contract Admin/Financial Reports	3
Adventures in Metal Detecting	4
LFEHOA Contacts, Volunteer Work Completed	5



President's Message

It's really hard to accept that we have reached the end of the summer already. I hope everyone has been able to enjoy the new picnic areas in the park and the improved picnic shelter area.

I would like to invite everyone to our annual HOA meeting. Every year we review what we have achieved for the year and plans for the future. We will be meeting in the Rainier Room at the Lake Wilderness Lodge (22500 SE 248th Street, Maple Valley), Thursday November 14th, at 7:00 pm. The Rainier Room is located on the second floor of the lodge (not the basement as before). Mark your calendars. We look forward to seeing you there.

As every year, we will have our annual HOA elections this winter. The positions that are open this year are Vice President and Treasurer. We will be taking nominations at the annual meeting and the week following. Voting instructions will come by e-mail about November 27th. Giles Nelson and Sandra Munsey will be running as incumbents. As always, we are looking for residents who are willing to serve on our committees such as architectural control and welcoming. If you are wondering what it might be like serving on the Board, volunteering for a committee would be a good way to check us out.

Please be advised that we are currently winterizing our park. The restroom will be closed until spring. Since the building is not heated, we have to drain the plumbing to prevent it from freezing.

One final announcement - because we have a small number of residents who fail to pay their annual dues until we finally threaten to file a lien, we will be initiating a \$25 fee for late notices. Each year we send many late notices to these residents with no response. Any resident with a financial need can contact the Treasurer and make arrangement for a special payment plan. As long as payment is made, no further late notices will be sent or late fees charged. The last thing we want to do is file a lien or charge late fees. But late payers are just not fair to those who do pay on time or to our volunteer Treasurer who has the unenviable job of collection. Money collected from this fee will be use to fund improvements to our common facilities.

Here is wishing a happy and enjoyable holiday season to all!

Wayne Anderson, President LFEHOA

Bulletin Board

Annual Homeowners Meeting - November 14th

Come join us at the Lake Wilderness Lodge, Rainier Room. The Rainier Room is located on the second floor of the lodge (not the basement as before.) Refreshments begin at 6:45pm and the meeting will start at 7:00 pm. We look forward to seeing you there!!

Be a part of your

LFE Community - Join the Board

The two positions up for election are Vice President and Treasurer. Homeowners who are interested are encouraged to attend our Annual Homeowners Meeting or reach out to a current board member. It's a great way to get involved and meet your neighbors.

VOLUNTEERS NEEDED

Bring Back our 4th of July Neighborhood Celebration

Lake Forest Estates is looking for volunteers who are interested in organizing a 4th of July "**Fun Day**" for the children in our community. In the past, parents organized a bike parade where the kids decorated their bikes and rode down to the park. Once at the park, kids engaged in fun games and were treated to munchies.

If this sounds like something you would be interested in organizing, please submit your ideas to the LFEHOA Board by emailing us at LFEHOA.POB0X782@GMAIL.COM



Contract Administrator's Report

Welcome to fall! As many of the long-term residents know, we are getting ready to winterize the restrooms at the park. We perform this annual work to prevent expensive plumbing damage to the pipes and fixtures. Without this temporary closure of the restroom we would not have facilities available to us during the summer. Thank you everyone for understanding why the restroom is closed at this time.

On another park related note, the chain link fence is being bent over extensively near the main gate from trespassers in the park. If you see anyone climbing the fence, please call 911 and give them the park address 23192 SE 253rd. They are happy (and usually quick) to respond to the calls. This prevents you from having a confrontation with unwanted guests in the park, ensures the safety of anyone (including trespassers), and mitigates the HOA liability.

Thank you,

Troy Loftus, Contract Administrator

Audit of Financial Records of LFE HOA

The financial statements of associations with annual assessments of \$50,000 or more shall be audited at least annually by an independent certified public accountant. The audit may be waived if votes cast by homeowners, in person or by proxy, vote to waive the audit.

In the past, homeowners have voted to waive the external audit and allowed the internal financial review committee, Debbie Brothers & Patti Hammett to conduct the audit for Lake Forest Estates.

Homeowners are encouraged to attend the Annual HOA Meeting or send in a proxy to vote on this important issue. Proxy's will be emailed to homeowners that will not be attending November 14th meeting at the Lake Wilderness Lodge.



New Bank Account

LFEHOA Board voted to close out our savings account with State Farm Bank and transfer the funds to Wells Fargo Bank. The benefits are (1) LFE will earn a higher annual yield and (2) The convenience of doing business locally.

The Wells Fargo logo, featuring the words "WELLS" and "FARGO" in yellow, stacked vertically, on a red square background.

**WELLS
FARGO**

Part 3—Adventures in Metal Detecting with Wayne & Giles

Lake Wilderness Depot, Maple Valley WA.

This is the third installment of "Adventures in Metal Detecting with Wayne & Giles." This month's article is a quick overview of the little bit of information we've discovered so far about the historic Lake Wilderness Depot train station.

The Depot was located right off the trail that runs through Lake Forest but at the West end of the lake right where a chain link fence comes down to the trail, but before the gravel road that comes down to the trail from the Highlands of Lake Wilderness neighborhood. It was on the opposite side of the trail (the old tracks) from the lake. If you look around there you'll see that there is a fairly large flat area that is now covered with various trees and bushes where the Depot once was located.

We've explored there a number of times now and each time have found interesting items of both historical railroad value and more modern things like a Swiss army knife that looks like it was in the ground for a very long time. This is all basically junk, but it is a lot of fun to find things. As always, if anyone is interested in joining us please let Wayne know.

Beyond the many old railroad spikes and rail backing plates that we've found, the most interesting thing so far was this piece as shown below, just as it first came from the ground, and then after a bit of cleanup using Wayne's soda blaster:



You can just make out some letters on it in a half circle and some numbers on the back side but it's just too rusted out to see what it says. After first uncovering the piece, we wondered if it was an old door to a wood burning stove, but Wayne did a bit of research on the Internet and discovered that it was a cover lid for the bearing journal box. The oiler would lift the lid and squirt oil in the box to lubricate the wheel bearings for the train cars.

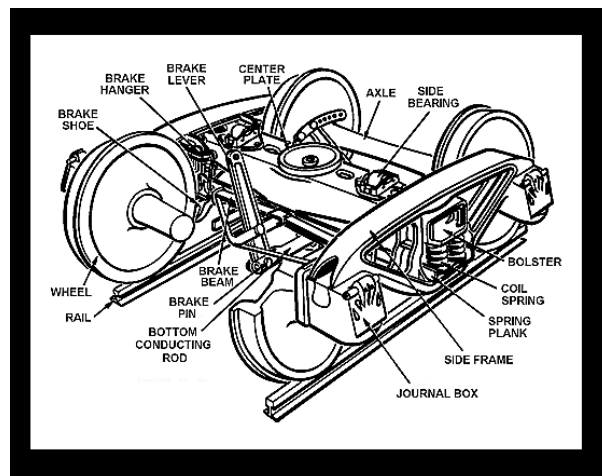

Cheers, Giles Nelson

LFEHOA Contacts

www.LakeForestEstatesHOA.com



<u>LFEHOA Elected Board Members</u>		
	President	Wayne Anderson 425-432-6087
	Vice-President	Giles Nelson 206-909-8431
	Contracts Administrator	Troy Loftus 206-293-6752
	Secretary	Rosanne Giurado 303-239-8603
	Treasurer	Sandra Munsey 425-432-2129
<u>Other Important Contacts</u>		
	Park (Shelter) Reservations	Rosanne Giurado 303-239-8603
	Park Keys	Sandra Munsey 425-432-2129
	ACC Committee	Bernie Glaze 425-413-0409
		Gary Schroder 206-947-2703
	Finance Committee	Patti Hammett
	Welcoming Chair	Kim Hancock 425-413-5086
	BlockWatch Chair	Sandra Munsey 425-432-2129
	Newsletter Publisher	Lorelie Kaid 425-413-9575
	Webmaster	Giles Nelson 206-909-8431



LFHOA Maintenance Work Accomplished	
<i>Since Last Newsletter</i>	
Task Completed	Completed By
Market approximate right-of-way location at SR169/SE 253rd intersection	Giles Nelson & Wayne Anderson
Mow fence slope area along lot 100 (3 times)	Giles Nelson
Restrung Sport Court Net	Wayne Anderson
Replaced Basketball Nets	Robert Hodges

If you see items needing repair, let us know! Volunteers are always welcome to pitch in!