

Ceramic Facade Systems





Made in Bavaria

Covering
Architecture
Worldwide

The In-house Planning Department or certifications are just two of many good reasons

As specialist for architectural and facade ceramics, AGROB BUCHTAL offers an extensive portfolio of products and services for modern and future-oriented building and designing with ceramics. The company's history already started in the 18th century. Today, AGROB BUCHTAL is a global player deeply rooted in Germany as traditional location.



In-house Planning Department. Specific relief of routine tasks opens up creative scope for specialists who convince in the form of their solution competence and offer technical building consulting on site.



Design. In co-operation with architects on the basis of concrete projects, new, individual products and special solutions are continuously created. Together with renowned product designers, AGROB BUCHTAL also develops new color concepts and surfaces which incorporate current trends in architecture.



Digital print. Modern technology creates facades in line with individual requirements. Accordingly, apart from wood or stone looks exuding a natural effect, metallic glazes are also possible which are resistant to environmental factors.



Experience. The innovative strength is based on know-how gleaned by several generations – extending as far back as the 18th century. By offering ceramic facade systems, the specialist for architectural ceramics has been making a name for itself all over the world for more than 40 years.



Colors. The enormous selection of colored glazes includes the harmoniously co-ordinated SpectraView color families as well as a wide range of design surfaces, as glazed or unglazed variants. On request, special colors are also developed to ensure maximum freedom of design.

Freedom of design. Additional possibilities associated with individual facade design arise from the use of various formats and surface finishes. Textured facade panels can loosen up expansive areas, for example, and emphasize the character of an entire building.



Ceramics. As a building material which has proved its value for thousands of years, ceramics displays ideal properties: it is non-combustible, resistant to chemicals, light-fast, resistant to pressure, impact and scratches, easy-care and hygienic.



Made in Germany. Modern production facilities, expertly-trained employees and efficient Quality Management are the basis for high-quality products. Ceramic facade systems offered by AGROB BUCHTAL are subject to on-going inspections and are manufactured exclusively in Germany. For guaranteed "Quality made in Germany".

Sustainability. Ceramics is harmless in terms of building biology. It scores well on account of its unlimited useful life and can be fully recycled.



Surface finishes. The innovative Hytect surface coating prevents the formation of algae, moss and microbes while the self-washing effect ensures permanently clean facades.



Special solutions. More than 20,000 glaze formulations, digital printing technology and other individual solutions open up unlimited possibilities for design – for new buildings and in stylish renovations of protected buildings.



Economic feasibility. Perfect substructures guarantee efficient panel installation. The low panel weight offers advantages in terms of statics, transport and handling.

Certifications. All systems are tested by the Buildings Inspectorate. Specialized product information supporting the auditors facilitates and accelerates certifications in accordance with LEED, DGNB and BREEAM.

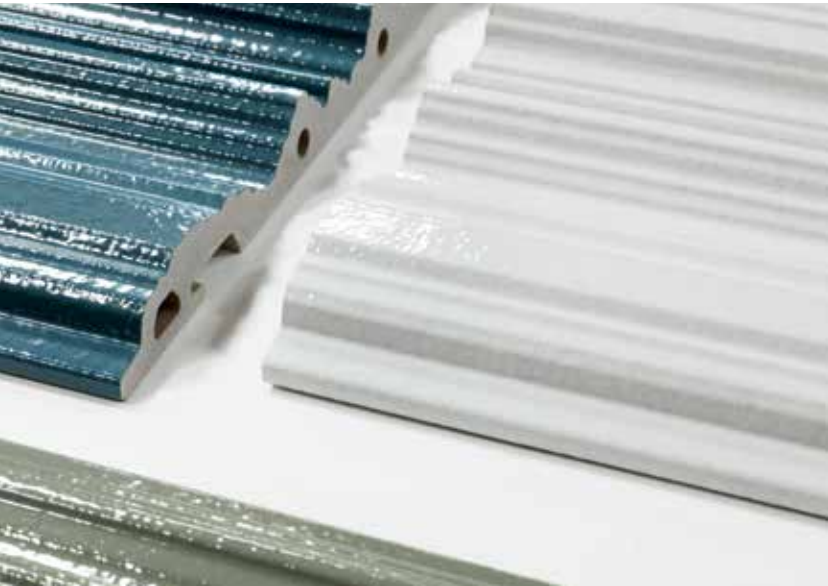

Surfaces and profiles

Matt, silky-matt or glossy as well as various three-dimensional cross-sections.

Page 56



Great color variety

More than 50 colors as well as numerous material looks and metallic glazes.

Page 60



Ceramic special pieces

Rectangular tubes and lamellar elements for setting accents or complete facade designs.

Page 94



Individual solutions

Special developments for individual concepts and unique solutions.

Page 132

CONTENTS



Sustainability

Support in the process and targets for obtaining Green Building certificates.

Page 20



References

Buildings with ceramic facades all over the world.

Page 30

Setting standards – for more than 40 years	8 – 9
The company	10 – 13
Rear-ventilated facades	14 – 19
Green Building	20 – 21
Hytect-technology	22 – 25
System overview	26 – 27

KeraTwin®

References	30 – 55
Surfaces and formats	56 – 59
Colors and glazes	60 – 65
Fastening systems, mounting instructions	66 – 89
Detail solutions	90 – 91

KeraShape®

References	94 – 105
Forms and formats	108
Mounting instruction	109
Fastening systems	110 – 113

KeraAion®

References	116 – 119
Surfaces and formats	120 – 123
Colors and glazes	124 – 127
Fastening systems, mounting instructions	128 – 129

KeraJoin®

References	132 – 139
------------	-----------

KeraYou®

References	142 – 149
------------	-----------

Service

System overview	152 – 153
In-house Planning Department	154 – 155

Ceramic facades for more than 40 years

A facade is far more than just the protective shell of a building. Its design not only characterizes the building itself, but also influences – often visible from far away – the urban environment.

As leading ceramics manufacturer, AGROB BUCHTAL has extensive know-how in all fields of Architectural Ceramics. With this background, the company has been developing and producing ceramic facade systems setting standards for more than four decades: functionally, aesthetically and by their product quality “made in Germany”. Curtain-type, rear-ventilated facades optimizing the energy efficiency and economical balance of buildings play a central part in this context. High competence in building physics results in technically sophisticated substructures, which ensure an efficient mounting and a safe fastening of the panels. These constructions are the connecting element from the wall – via the insulating layer – to the facade cladding and support the realization of creative ideas. The In-House Planning Department is permanently further developing the various systems and accompanies the implementation of individual concepts world-wide – on request also on location at the construction site.



Polytechnikum (polytechnic Institute), Hongkong, China / Architect: Messrs. Palmer & Turner



Musée d'Arte Moderne, St. Etienne, France / Architect: Didier Guichard



Thermal power station, Viborg, Denmark / Architect: Arkitekterne, Peter Kjelgaard & Thomas Pedersen M.A.A., Viborg

↑
1976

↑
1987

↑
1996



Muhammad Ali Center, Louisville, USA / Architects: Lee H. Skolnick Architecture + Design Partnership



Jurubatuba Building, Sao Paulo, Brazil
Architects: alériaTaurino, Sao Paulo/SP, Brazil



Ilot de l'Octroi, Rennes, France
Architect: MVRDV, Rotterdam, the Netherlands

↑
●
2005

↑
●
2010

↑
●
2022

Projects all over the world

Thanks to the variety of colors, sizes and surface finishes, supplemented by fastening systems making installation efficient and safe even on complex bases, ceramic facade systems offered by AGROB BUCHTAL have been popular all over the world for decades.

On all inhabited continents, from Canada to Brazil, from Northern Sweden to South Africa, from Russia to China and Australia, the systems comply with various architectural design concepts in a wide variety of cultures and climate zones around the world, whereby special productions are often used for artistic facade design. The range of projects includes hotels, office buildings and hospitals, residential buildings, sports facilities, railway stations and airports. A special part is played by 3D facade ceramics as a means of providing shade in tropical heat.



Pauley Pavilion, Los Angeles, USA



91, Leonard Street, New York, USA



CCQ, Montreal, Canada



Liberty Plaza, Panama City, Panama



Jurubatuba, Sao Paulo, Brazil



Ministerio de Ciencia, Buenos Aires, Argentina



Downing Students City Village, Belgrade Plaza, Coventry, Great Britain



Ilot Queyries, Bordeaux, France



Orangerie de Souissi, Rabat, Morocco



■ Clarion Hotel, Helsinki, Finland



■ Business Center, Jekatarinburg, Russia



GIZ Campus, Bonn, Germany



■ Microsoft Campus, Shanghai, China



■ Airport, Assuan, Egypt



■ Lee Shan Building, Hong Kong, China



■ Pretoria Tower, South Africa



■ Adventist Hotel, Sydney, Australia

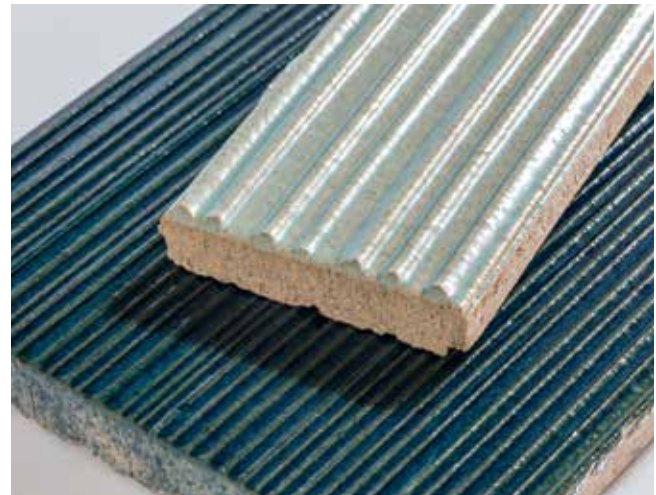

Ceramics: a raw material of architecture

Already for more than 2,000 years, ceramics has been a “raw material of architecture“. Colored tiles and ceramic decorations were already used by the Etruscans in their buildings. The definition of ceramics stands for all inorganic non-metallic materials which are first shaped and fired afterwards.

Clay is the main component of ceramic tile masses and developed as a result of the weathering of rock containing feldspar (e.g. granite) due to exposure to wind, water and the seasonal temperature differences. This weathering took place millions of years ago in the Tertiary period. It is composed of fine-grained minerals, with the clay minerals (sheet silicates) lending the clay its plastic properties.

Due to the special requirements that have to be met with regard to the ceramic manufacturing process and also the product itself, other raw materials such as, for example, feldspar (15-25 %), chamotte (10-20 %) and kaolin (0-10 %) must be added to the clays (50-70 %). The preparation

comprises the homogeneous mixing of all components. The obtained mass is further processed in the ceramic manufacturing process.

Concerning the shaping of tiles, basically two methods can be distinguished: on the one hand, the dry-pressing, and on the other hand, the extrusion. In the shaping process, the prepared mass – as granulate or in plastic state – is pressed in or through a mould under very high pressure. The choice of the respective shaping method depends on the desired properties of the finished product. AGROB BUCHTAL uses both methods.



The perfect solution: curtain-type, rear-ventilated ceramic facades

Aesthetics, economic efficiency and sustainability: the combination of these three factors is the basis for the growing success of curtain-type, rear-ventilated ceramic facades. The decisive reason for the technical superiority of these systems is the structural separation of the functions of heat insulation and weather protection.

The ventilated cavity between the ceramic panels and insulating material regulates the building's moisture balance, directing moisture outwards and guaranteeing swift drying of damp exterior walls. The insulating material stays dry and fully functional while the indoor climate is improved.

Regardless of the building height and utilization, mineral insulating materials are usually used for rear-ventilated ceramic facades. As the system permits installation of any thickness of insulation material, the specifications of the Energy Savings Ordinance can also be easily met.

The permanently safe connection between ceramic panels and supporting outer wall is ensured by the substructure where sophisticated constructions make for efficient installation and compensate for uneven surfaces on the walls. In addition, aluminium substructures play a key role when it comes to lightning protection. As an indestructible material, ceramics not only offers optimum protection against rain and snow – panels and special pieces in a contemporary range of colors also characterize the outer appearance of the building and support the architect in realizing his ideas. With their great variety of colors, formats and surface textures, the curtain-type, rear-ventilated facade systems offered by AGROB BUCHTAL represent an ideal basis and maximum freedom of design when planning new buildings or renovating existing ones. And those on the lookout for something special will also find what they are looking for here, as individual special productions are one of the company's strong points.

System: structure and function

Thanks to the air space between the outer facade cladding (ceramics) protecting the building against snow and rain and the insulation (mostly mineral wool), curtain-type, rear-ventilated facade systems improve the indoor climate, save heating costs and conserve natural resources.

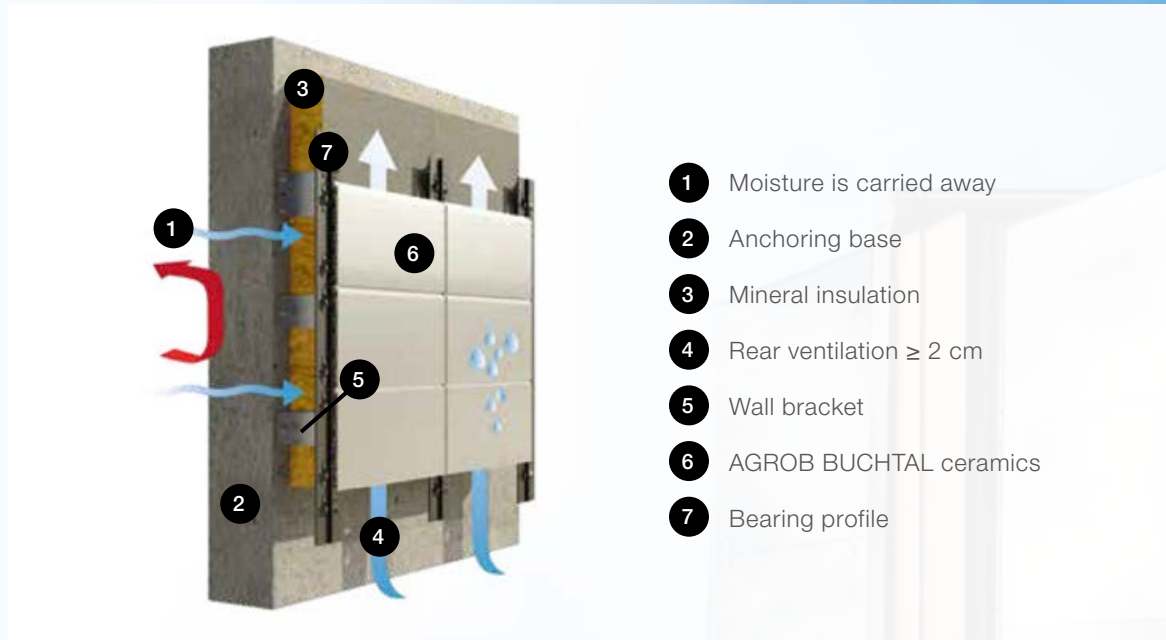



Commercial Kitchen Voimian Pata, Tampere, Finland / Architect: RE-Suunnittelu Oy
Products: Design unglazed, KeraTwin®, KeraTwin K20®, Natura unglazed / Photo: Näkymät Visuals OY – ABL-Laatat

Sustainability and conservation of resources also play an increasingly important part when it comes to planning and designing facades. Ceramic curtain-type, rear-ventilated facade systems are practically unbeatable in this area. As the panels are resistant to frost, light- and color-fast, non-combustible and very impact-proof, they have a practically unlimited useful life. Whether glazed or unglazed, the highly-resistant surface made of fired ceramics makes them resistant to extensive soiling such as graffiti. And the Hytect surface with its self-washing effect also reduces cleaning requirements. When the time comes to demolish the building,

all components of the facade cladding – ceramics, mineral wool and the aluminium used for the substructure – can be easily sorted and redirected to the respective material circuits. On the basis of these material properties, ceramic curtain-type, rear-ventilated facade systems are eminently suitable for use in sustainable construction projects aiming for Green Building certificates such as LEED, BREEAM or DGNB – especially considering that AGROB BUCHTAL provides the architects with support during the certification process in the form of documents for auditors which are specially designed for this purpose.

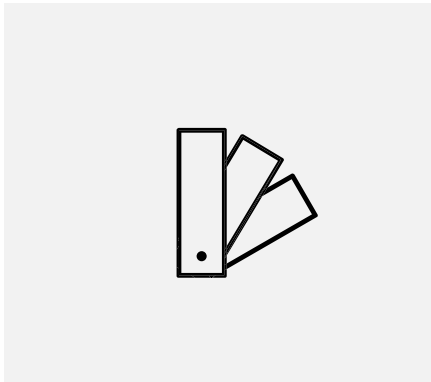

Variety of design

Curtain-type, rear-ventilated facades permit facade design which is independent of the building grid. With a wide selection of materials and sizes and an extensive range of harmoniously co-ordinated colors in various surface finishes, planners and architects have plenty of scope for implementing their ideas. Accordingly, the function and character of the building can be emphasized, attention drawn to significant components or surrounding colors integrated in the design.

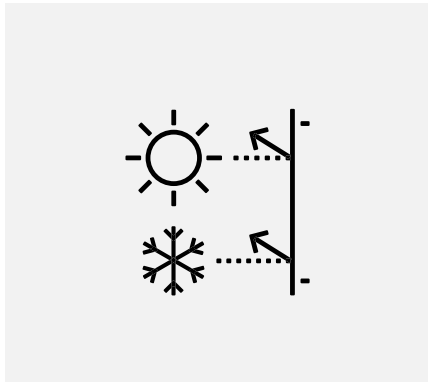

Protection against heat and cold

In combination with mineral insulating materials and an innovative substructure, curtain-type, rear-ventilated facades can achieve any U-value. This ensures good insulation and low heat loss in winter yet good indoor climate conditions in summer. Energy requirements for heating and cooling are reduced. Furthermore, ceramics displays practically no temperature-induced linear expansion – unlike other materials such as metal or composites.

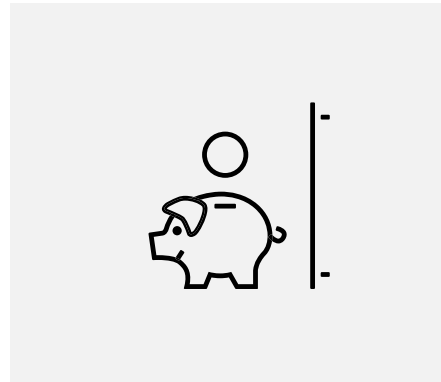

Economic feasibility

The curtain-type, rear-ventilated facade design protects the components underneath against a wide variety of environmental factors. This results in a long useful life on the part of the entire construction, low susceptibility to damage, comparatively low maintenance costs, cost certainty during the planning phase, and installation independent of the weather.

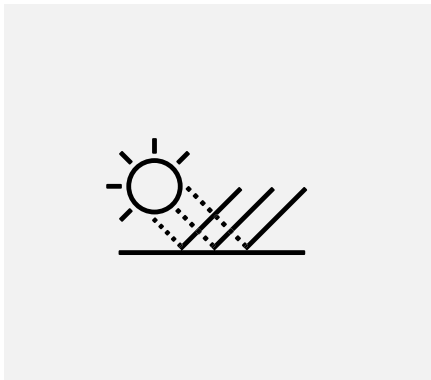

Light- and color-fast

Fired at high temperatures of over 1,200 °C, environmental factors such as heat, cold and solar radiation (UV light) do not have any lasting effect on surface appearances. Colors remain unchanged even after several decades.

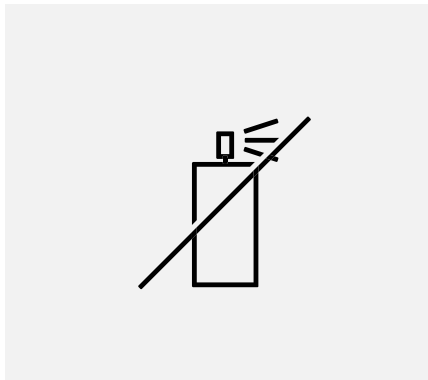

Anti-graffiti

Facade ceramics by AGROB BUCHTAL meet the requirements on cleaning according to ReGG III of the Gütegemeinschaft Anti-Graffiti e.V., whereby the maximum performance class is achieved. This has also been confirmed by an independent test institute.

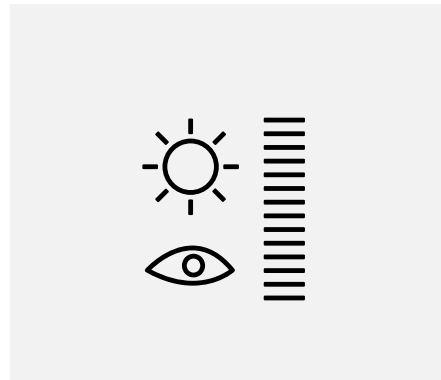

Sun and visual protection

Solar protective equipment mounted on the outside is most effective in reducing the energy input via translucent layers. Rear-ventilation also offsets surface heating.

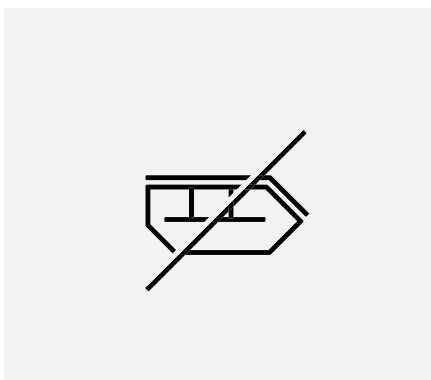

Less waste on site

As the ceramic elements are robust and resistant to weathering factors such as rain and frost, they do not require complex packaging but are secured on standard pallets for delivery to the building site. This accelerates on-site processes and means that little waste is incurred which, in turn, needs to be disposed of.



Sustainability

Ceramic facades are suitable for both new buildings and renovations, and permit a lengthy useful life or extend the useful life of existing buildings. The Hytect surface with a self-washing effect supplied by AGROB BUCHTAL ensures a low cleaning effort and improves the quality of air in the vicinity of the building.

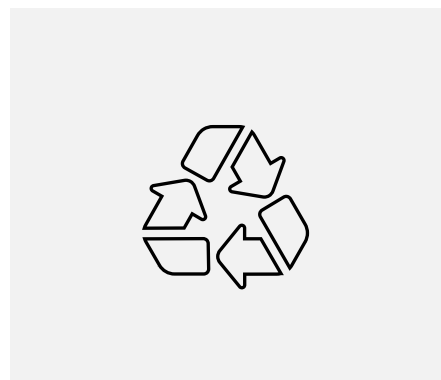

Material cycle

Good for the environment: the construction of the ceramic facades allows for unmixed deconstruction. The dry-laid facade panels can be removed and reinstalled in the same way as the facade systems. This means that all components can be recycled without any problems in case of dismantling.



Residential building, Basel, Switzerland / Architect: Koechlin Schmidt Architekten AG, Basel, Switzerland / Products: New Wave / Photo: Felix Odermatt



Fire safety

Fire safety experts rate curtain-type, rear-ventilated facades as very safe in terms of technical fire safety. Free selection of the system components makes it possible to meet all technical fire safety requirements. As a general rule, the following applies: all components of curtain-type, rear-ventilated facades are to be made of non-combustible materials. The DIN 18516-1 in conjunction with Annex 2.6/4 of MLTB regulate fire safety for curtain-type, rear-ventilated facades. Detailed information on measures, precautions and rules can also be found in the applicable state construction laws of the 16 German states (LBO), in the general DIN and VDE provisions as well as in the information provided by building supervision.

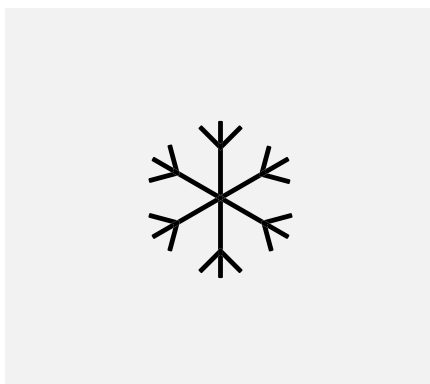

Resistance to frost

Extruded stoneware panels are fired at a firing temperature of approx. 1,260 °C and are extremely resilient. This also includes frost resistance in accordance with DIN ISO 10545-12. In test procedures, the panels are saturated with water before testing for soundness under vacuum after 100 frost-thaw cycles.

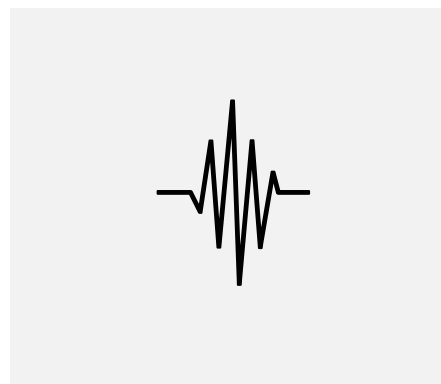

Earthquake-safe

All products are constantly tested at recognized material testing institutes in Germany and abroad. Specific national certificates governing earthquake stability, for example, are available. On request, copies of these certificates and approvals can be made available at any time.

Safety first

The ceramic facades offered by AGROB BUCHTAL are not only efficient and inexpensive to install, they also meet even increased requirements on safety in their capacity as sophisticated systems – in both new buildings and renovations.

Ceramic facade elements score particularly well when it comes to meeting fire safety specifications: this external wall cladding corresponds with the highest classification of “non-combustible” and

also meets the additional requirements governing smoke production and flaming droplets/particles as specified by the DIN EN 13501-1 standard. Even in the case of a fire, no vapours or toxic gases are released. As a building material, facade ceramics is regarded as displaying a recognized and stable performance in terms of its reaction to fire as it does not contain any organic material. When planners or contractors choose non-combustible mineral insulation and consider installing fire barriers, the result is

an overall construction offering maximum fire safety. Not that any compromises need to be made in terms of design either: based on its material, ceramics already complies with the “non-combustible” requirement with the result that the extensive range of colors, sizes, surface finishes and ceramic special pieces is available in full for creative solutions with a high degree of individuality and design quality.

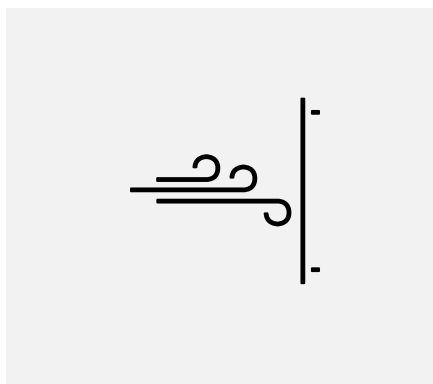

Design loads

As a static link, the substructure absorbs all loads and directs them safely into the anchor base. The cladding fastenings secured to the substructure link the system components without technical restraint and transfer all loads.



Lightning protection

The system has also proved its worth during thunder and lightning storms. The metal substructures conduct lightning strikes away or can be combined with lightning protection devices. Accordingly, lightning is conducted to earth and also forms an electromagnetic shield protecting the electronics inside the building.

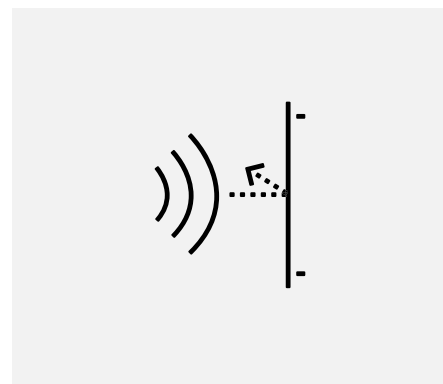

Noise protection

Curtain-type, rear-ventilated facades not only reduce thermal loss; they also protect the building interior against noise immissions. Thanks to the great absorption capacity of the mineral insulating materials combined with the extensive external cladding, a sound reduction index can be achieved which is up to 14 dB higher.

Ceramic tiles for sustainable buildings



Information for auditors
by AGROB BUCHTAL

All building certification systems give building materials high priority at the assessment. For builders, this means that already the choice of the appropriate material may have a positive influence on a certification process and thus also on the sustainability performance of a building.

The factor “material“ is relevant in all of the four cycle phases, i.e. during the manufacturing, the construction, the operating and the deconstruction phase of the building. In the manufacturing phase, the question is how sustainably the respective building materials are extracted and/or produced or with which energy input they are transported to the respective construction site. In the operating phase, the focus is above all on the influence of materials used on the health and the well-being of the users of the building as well as on technical and energy-related properties.

Making all relevant product properties transparent is advantageous already during the certification. Because the simpler and clearer all the information is prepared, the easier is it for the auditor to assess the material with regard to its effects on the building. That is why AGROB BUCHTAL has compiled separate auditors' information for the internationally established certification systems LEED, BREEAM and DGNB in a brochure.

LEED

This green building label enjoys the greatest international popularity. LEED-certified buildings can be found in 135 countries around the world. Almost 54,000 buildings world-wide are certified or at least registered in accordance with the LEED standard, of which more than 44,000 are in the USA. Around 48 per cent of all new American construction projects are developed as green LEED buildings. The American sustainability label is also extremely successful abroad: in the People's Republic of China, for example, more than 1,100 buildings comply with the LEED standard while there are over 800 in the United Arab Emirates and more than 600 in Brazil. In Germany, many property owners also rely on the LEED label with almost 300 LEED-certified buildings scattered between northern Germany and Lake Constance in the south. The rating system involves points with 69 criteria in seven categories: Sustainable construction sites, Water efficiency, Energy and atmosphere, Materials and resources, Air quality and buildings, Innovative design and Regional priority. Many large international corporations have made LEED certifications obligatory for new rentals or construction of new company buildings.

DGNB

The certification system applied by the Deutsche Gesellschaft für Nachhaltiges Bauen (German Sustainable Building Council, DGNB) was launched in 2007. This masterpiece of German engineering science raises the benchmark for some – especially technical – criteria when compared to the British label. It is more exact which means it is practically impossible to achieve a 100 % rating. Overall assessment incorporates five segments: Ecological quality, Economic quality, Socio-cultural and functional quality, Technical quality and Process quality. For each application, the certificate also demands a comprehensive analysis of life cycle costs in accordance with standardized criteria, a life cycle assessment and a decommissioning concept.

BREEAM

The mother of all sustainability labels for property although meanwhile overtaken by LEED in terms of popularity. Around 250,000 buildings world-wide comply with the requirements of the British sustainability catalogue, most of which can be found in the home of the BREEAM label, Great Britain, where the astonishing success of climate-friendly property is also largely due to state regulations: all new residential buildings must satisfy the BREEAM Code for Sustainable Homes. In Germany, too, the BREEAM label is often the green building standard of choice. Developed for rating entire properties, the BREEAM In-Use Certificate evaluating the environmental compatibility of existing property has also been available on the German market since 2012 with ratings being awarded in the following categories: Energy, Water, Land use and ecology, Health and well-being, Transport, Materials and Pollution.



Green Life Headquarters Banca Crédit Agricole, Parma, Italy / Architect: Frigerio Design Group / Photo: Frigerio Design Group / **LEED PLATINUM**



The Viridian, Boston, USA / Architect: Bruner/Cott & Associates / Photo: Fred Clements / **LEED GOLD**



Orchard Hotel, Nottingham, Great Britain / Architect: RHWL Architects / Photo: Martine Hamilton Knight Photography / **BREEAM EXCELLENT**



Société de Transport de Montréal, Montreal, Canada / Architect: Lemay / Photo: Marcin Wozniak / **LEED GOLD**



Finchley Memorial Hospital, London, Great Britain / Architect: Murphey Philipps Architects / Photo: Benedict Luxmoore / **BREEAM EXCELLENT**



Alterszentrum Sonnenhof (old people's home), Wil, Switzerland / Architect: Meier Hug Architekten / Photo: Adriano Faragulo / **MINERGIE-STANDARD**

HYTECT

Added value for people,
buildings and cities

Downing Students City Village, Belgrade Plaza, Coventry, Great Britain / Architects: Simpson Haugh
and partners group / Year: 2017 / Products: KeraTwin® (K20) / Photos: Simon Hadley

Ceramic facades with self-washing effect



This is how the self-washing effect* of Hytect works: when it rains, a thin water film forms on the surface of the Hytect ceramics, which infiltrates dirt and finest dust particles.

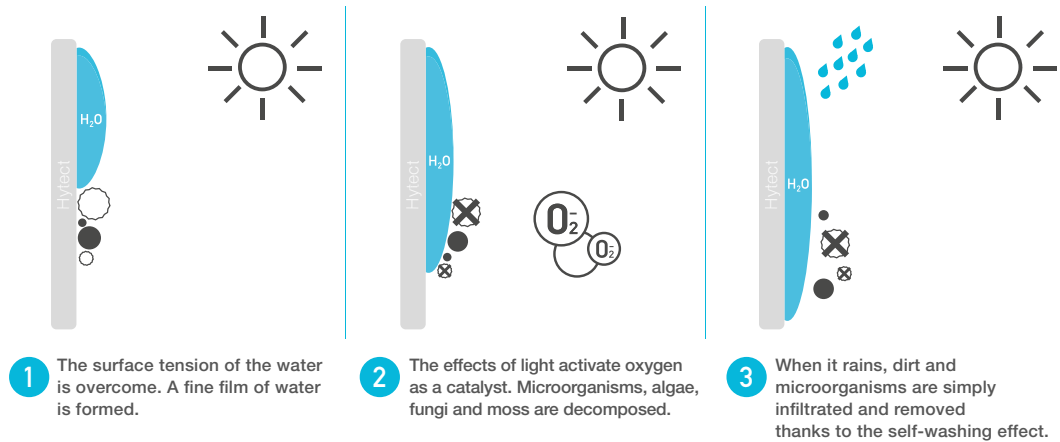

The Hytect technology helps to keep facades and surfaces clean. In addition, they are very resistant. Graffiti can be easily removed with appropriate means without leaving any damage to the surface. All glazed facade panels of AGROB BUCHTAL are provided with Hytect surfaces as standard.

*in the case of glazed panels

without HYTECT

Building in Bratislava, 17 years old



with HYTECT

Building in Bratislava, 16 years old



One city, one environment – the same look – but first without and then with Hytect. Whereas the facade above has become dirty and grey over time because dirt and moss have adhered to it, the building shown below has lost none of its immaculate appearance even after many years thanks to Hytect. Mind you, without being specially cleaned. And without the use of environmentally harmful fungicides or other chemicals. In this way, Hytect contributes to sustainability.



Antakalnio terasos, Vilnius, Lithuania / Architects: JP Pajegos UAB, Vilnius / Year: 2012 / Products: KeraTwin® / Photos: Leonas Garbaėauskas

For everlasting beautiful facades

Hytect ceramics is sustainable, economical and efficient on facades. Among other things, because Hytect facades basically clean themselves.

The self-washing effect of Hytect facades has a long-term effect in terms of costs. However, it also increases the visual attractiveness of buildings – because they are simply always clean. Just as important: Hytect facades are almost indestructible. They are easy to install and can be combined with various types of thermal insulation. All this makes their use financially attractive and

sustainable for the environment. Rain and moisture usually have a negative effect on conventional facades. In the case of Hytect facades, the opposite is true. Because when it rains on them, the natural self-washing effect of Hytect starts. Dirt is infiltrated and simply washed away by the rain. By photocatalysis, a particularly great amount of active oxygen is produced on the surface

of the ceramics. Moss, algae, fungi etc. are thus prevented from growing on the facade. This also saves cleaning costs. In addition, Hytect facades are resistant to frost, wind and weather. Because they are extremely robust. Renovations thus become superfluous – and the economic efficiency increases.

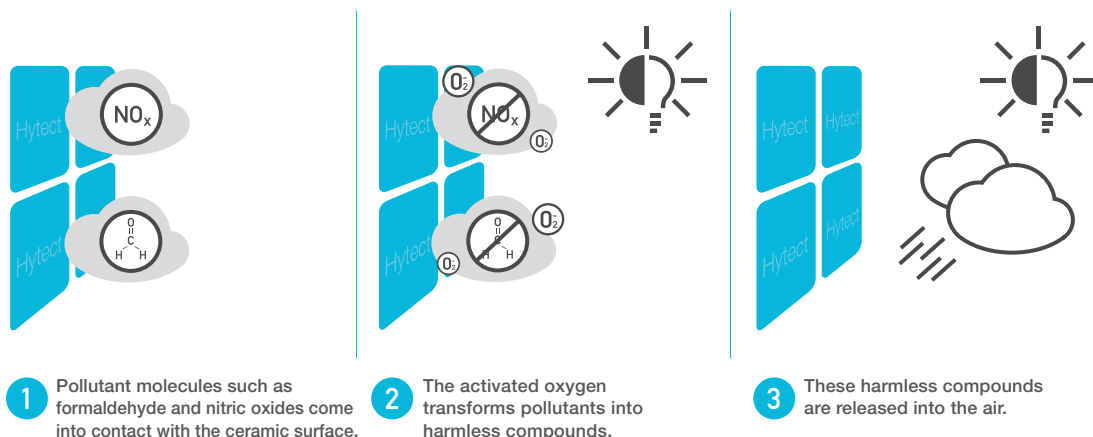



A clean solution for cities and people

Facades can also contribute a lot to make our cities cleaner.

Hytect neutralizes nitrogen to a degree which should not be underestimated. We checked that again, and we found out that 1,000 m² of Hytect facade neutralize approximately the NO_x emissions of a Euro 5 car over a distance of 10,000 kilometres every year.

By the way, we Germans drive our car 35 kilometres a day on average. Thus, the facade neutralizes the average daily drives of around 286 persons in Germany – of course again in Euro 5 vehicles. If one calculates with the newer Euro 6 vehicles, the distance even increases to 22,000 kilometres – or the daily drives of 628 persons.

Thus, Hytect facades indeed can be a contribution to sustainably improving the air quality in cities. They definitely also are a contribution which benefits the environment. Because Hytect facades rarely have to be cleaned. This also helps to protect the environment, because the use of chemical agents or electrically operated cleaning equipment simply is not necessary.

We checked it again:

1,000 m² of Hytect facade neutralize the NO_x of 1,000 driven distances of 10 km per year.

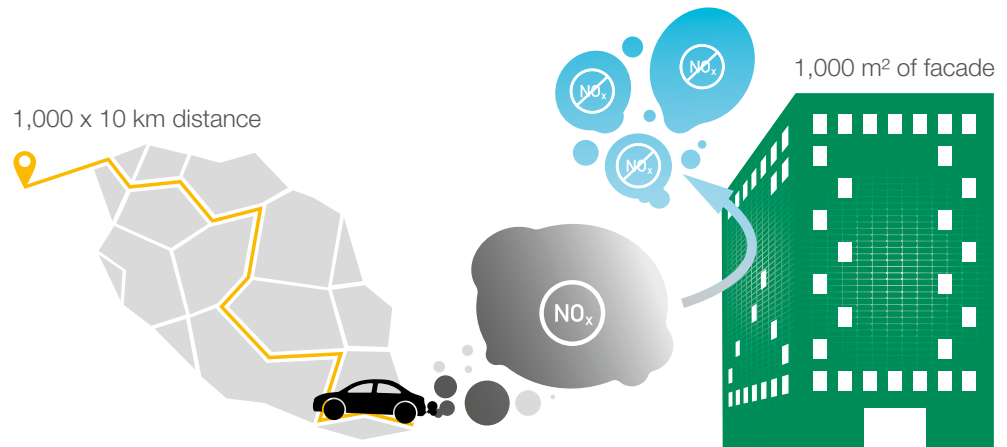

NO_x reduction Hytect

Emission standard - diesel vehicle	EURO 3	EURO 4	EURO 5	EURO 6	
Reduction rate Hytect	0.4	0.4	0.4	0.4	mg / m ² Hour
Active time 1	12	12	12	12	Hours / day (lightness)
Active time 2	7	7	7	7	Days / week
Active time 3	52	52	52	52	Weeks / year
Surface	1,000	1,000	1,000	1,000	m ²
NO _x emission	500	250	180	80	mg / km
Equivalent in km	3,000	7,000	10,000	22,000	km / year
Distances	300	700	1,000	2,200	of 10 km

Certificate concerning the reduction of pollutants



THREE SYSTEMS for all facades

Protecting buildings against atmospheric influences is one of the classic functions of any facade cladding. Today, in consideration of the climate and natural resources, demanding energetic standards also need to be complied with and can be best met with curtain-type, rear-ventilated facades.

This not only applies to new buildings, but also to the renovation of existing buildings worth conserving. With the three systems KeraTwin®, KeraShape® and KerAion® – all of them made of extruded ceramics – AGROB BUCHTAL offers the planning architect the possibility to find the most appropriate solution.

KeraTwin® is convincing thanks to its architectural versatility and visual variety. Apart from the great selection of sizes with standard heights of 15 to 60 cm and lengths of up to 180 cm, a wide and varied range of harmoniously coordinated color families is also available – and rounded off by vivid contrasting colors. Furthermore, the system offers various fastening and design options with installation possible in joint cuts, with or without joint profiles. The panels can be arranged horizontally, vertically and in various bond patterns.

Installation is possible on practically any base, including ceilings, in a single panel geometry and a single panel thickness.

KerAion®, the classic among ceramic facade systems, has been installed successfully all over the world for decades. Apart from the well-known advantages of ceramics as a material, it is above all the sophisticated technique which speaks in favour of this system: KerAion® facades conform to standards and official approvals and, thanks to their practically unlimited useful life, are also very economical. With their well-balanced range of colors, variety of sizes, and project-specific special productions, they also lend buildings with large surfaces an individual look. The large formats of 60 x 60 cm, 90 x 90 cm and 60 x 120 cm with a panel thickness of only 8 mm offer additional design options.

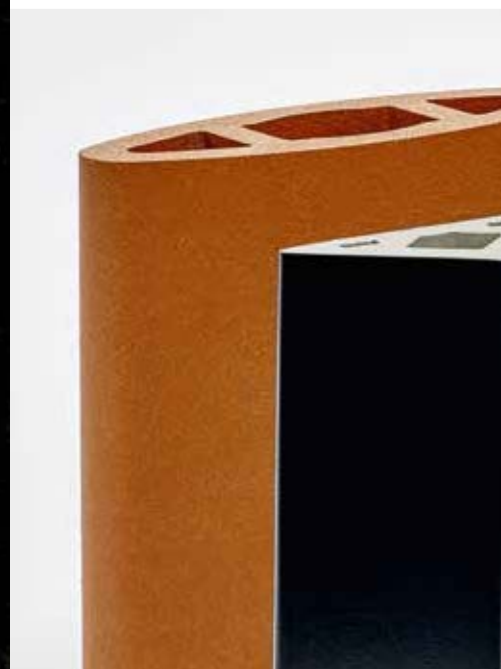



KeraTwin®

The particularly efficient laying and practically unlimited application possibilities thanks to diverse fastening systems speak in favour of KeraTwin®.

Further system advantages:

- great variety of sizes up to large formats of 60 x 180 cm
- particularly wide and varied range of colors
- structuring of the surface possible: grooves, waves etc.
- panels available both glazed and unglazed
- easy to clean and environment-friendly thanks to Hytect



KeraShape®

With its diverse profiles, KeraShape® fulfils numerous functions – from the protection against the sun and view to the three-dimensional design of facades.

Further system advantages:

- suitable for horizontal and vertical mounting
- wide range of colors, glazed and unglazed
- ideal for the execution of corners and projections
- elements in lengths of up to 180 cm



KeraAion®

The classic, which has proved itself for decades, also offers square formats and lends large-size facades a characteristic look. In addition to the usual rectangular and square panels, large formats in 60 x 60 cm, 90 x 90 cm and 60 x 120 cm are also available.

Further system advantages:

- great variety of sizes up to the large format of 90 x 90 cm, 60 x 120 cm
- wide range of colored glazes with Hytect
- advanced technique developed in the course of decades
- statically advantageous thanks to low panel weight

A photograph of a modern building facade featuring a white ceramic tile system (KERATWIN) and a wooden grid facade. The image shows a close-up of the white ceramic tiles on the left and a wooden grid facade on the right. The text 'KERATWIN® Ceramic system' is overlaid on the white ceramic section.

KERATWIN® Ceramic system

With its variety of colors, formats and surface finishes, KeraTwin® offers the architect enormous freedom of design. And as diverse fastening alternatives ensure technical and structural versatility, this system offers the appropriate solution to any challenge – even on difficult bases.

As a facade system with the widest variety of colors, KeraTwin® enables any architect to realize his creative ideas. Therefore, apart from the “SpectraView” range of colors comprising nine harmoniously coordinated color families and contrasting colors, the “Natura unglazed”, “Design unglazed” and “Design glazed” color systems are also available.

On request, the panels are also supplied with profiles which, due to their three-dimensional texture, can make large facades appear less monotonous and lend an entire building a distinctive character. The joints are realized in such a way that the construction is optimally protected against driving rain. With their relatively low weight of 32 kg/m², the panels are easy to transport and install.

The KeraTwin® system variants essentially differ in terms of their fastenings which depend on the requirements of the specific project. The vertical K20 system rail, for example, offers extensive freedom of design and a wide range of accessories. As the panels are simply hung on the system rail, no additional tools are required for installation. Even faster and more efficient laying is possible using the innovative K20 T-profile which requires fewer individual components in the substructure. The vertical K20 Omega profile has proved itself as a specialist for efficient installation on difficult bases, e.g. walls with post-and-beam construction. The system variants OmegaS and OmegaV offer further possibilities: large panels of up to 60 x 180 cm can be mounted vertically or in any bond patterns.



Downing Students City Village, Belgrade Plaza, Coventry, Great Britain / Architects: Simpson Haugh and partners group / Year: 2017 / Products: KeraTwin® (K20), Photos: Simon Hadley



Developed in the laboratory: The future of the city

The Dutch architecture office MVRDV has completed a residential building in Bordeaux. Ilot Queyries is unusual in many respects – but the striking ceramic outer skin is especially so. The building sculpture is located east of the Garonne river, directly opposite the largest cathedral of France, which marks the historic centre of Bordeaux as an urban high point. With the new building, the architects want to give the life of the city, which is in the process of growth, a sustainable design. They mirror the master plan of the old town on the river bank side of Bastide Niel and make the new residential courtyard, which encloses a park-like green area, the visual landmark in the neighbourhood. In this way, the future of the city is connected to its history as if it were a matter of course. A contemporary interpretation of the building traditions of Bordeaux.

If you think of ceramic facades, you probably have small houses from southern countries in mind. The dimensions here are completely different and yet the material proves to be the right choice for Ilot Queyries in several respects. The imposing new building not only catches the eye with its heights, depths and slopes – especially its radiantly bright, three-dimensional building envelope attracts attention already from afar. Differently profiled tiles of the KeraTwin® system make this possible. They skilfully catch the light and give the architecture a lively, sculptural appearance with sun reflections and shadow play, making it a ceramic landmark. The ceramic facades also spill over confidently onto the roofs. With sharp, precise edges, they contrast with the red plaster

of the inner courtyard, which seeks its way out here and there in recesses, sight openings and passages.

The large project was commissioned by two clients, Kaufman & Broad and ADIM. It forms a unit with three smaller adjacent residential buildings by JA Joubert Architecture, the office of the former MVRDV employee Marc Joubert, who had also worked on the overall plan of the ensemble, and the local firm Flint. The Flint architects also were the co-designers of MVRDV, both of the main building and – together with Sabine Haristoy – of the landscape of the large inner courtyard and the surrounding urban spaces.



According to Bertrand Schippan, a partner of MVRDV, the inner courtyard is both a space for the residents and accessible to everyone, as it is part of the public area of Ilot Queyries. The building is located on the edge of Bastide Niel, a neighbourhood which is being completely redeveloped. The aim is to urbanize this outlying area of the city, preserving or reusing as much as possible of its heritage of warehouses, barracks and railway tracks, as well as adding new elements.

Bastide Niel will be home of around 3,500 families in the future. It will also house offices, facilities of Bordeaux University, shops and several public institutions. MVRDV has drawn up the master plan for this 35-hectare area, which will create a sustainable environment mainly dominated by pedestrians and cyclists, with narrow streets and the atmosphere of a historic city centre. Schippan explains: "Ilot Queyries is just outside the boundaries of Bastide Niel, but meets all the guidelines we have created for the neighbourhood."

As with all the buildings in Bastide Niel, the overall shape allows optimal access to daylight in each flat and at least two hours of direct sunlight per day reaching the ground floor. This

explains the irregular angles of the roofs. The master plan also dictates that each building fills the envelope, but allows for cuts and openings as long as they do not affect the overall contour of the volume. Another rule states that the exterior facade of each building is clad with a material that matches the "blond" color of the stone traditionally used in Bordeaux, such as marble, granite, concrete or ceramics. The cuts in the building can be made with other materials, which can also be more colorful, as the Ilot Queyries project shows. The "flesh" of the building shows a warm red plaster under its light skin.

For MVRDV, the Ilot Queyries project is a kind of laboratory of the modern city, combining intimacy with density, ecology, light and comfort. It comprises 282 flats, a mix of affordable and market-rate units, and a restaurant in the crystalline upper part of the complex. 200 metres of building length, 10,000 m² of ceramic facades installed, varying their heights up to nine storeys, with a dynamic inclination of 14 to 45 degrees – a glance at the key data makes it clear: without the support of a project-specific and trend-setting surface design, this equally unconventional and identity-creating architecture would be difficult to succeed.





Ilot Queyries, Bordeaux, France / Architects: MVRDV, Rotterdam, the Netherlands, co-architect: Flint, Bordeaux, France / Year: 2020
Products: KeraTwin® / Photo: Art-Milan Mazaud, Bordeaux



KeraTwin®

According to the architects' specifications, the ceramics specialists from AGROB BUCHTAL designed and produced custom-made versions of the state-of-the-art facade system KeraTwin® for Ilot Queyries. First of all, there is the special color: MVRDV carefully chooses a light grey, which combines the vertically laid panels into a harmonious facade appearance. The building unobtrusively blends into the neighbouring architecture. The true design virtuosity of ceramics as a facade material becomes apparent in the combination of color and three-dimensional texture. As a playfellow of light, it brings an almost unlimited number of shades into the monochrome coloring. For Ilot Queyries, the specialists from AGROB BUCHTAL therefore developed ceramic elements with three different cross-sections according to the architects' specifications. Their raised profile not only enlivens the color,

but also allows residents and passers-by to experience their building in the greatest diversity.

Apart from contextual and design considerations, the light exterior color is also motivated by environmental issues, as MVRDV partner Schippan points out, to give the building a high albedo (reflectivity) which helps to avoid the urban heat island effect. And without question, one of the most important parameters for sustainable urban design also lies in achieving long-lasting building life cycles. The AGROB BUCHTAL ceramic facades are provided with Hytect technology, an innovative surface with a self-washing effect. They guarantee that Ilot Queyries will continue to shine in unchanged and impeccable aesthetics even when a new zeitgeist overtakes the innovative architecture and speaks of it as a historical building sculpture in the neighbourhood. Until then, the Hytect tiles with their antibacterial effect not only defy all weather conditions, contamination as well as moss formation and are impressive because of significantly low maintenance costs – they also reduce air pollutants such as nitrogen oxide and actively contribute to a healthier air quality: a gift to the inhabitants of the city of the future.





KeraTwin®





WINTRINGHAM
PRIMARY ACADEMY



Wintringham Primary Academy, St. Neots, Great Britain / Architects: DRMM Architects, London, Great Britain / Year: 2020
Products: KeraTwin® (K20) / Photos: Simon Hadley, Birmingham

Functional building with high architectural quality



Main fire station Regensburg, Germany / Architect: Diezinger Architekten / Year: 2019 / Products: KeraTwin® (K20)
Photos: Atelier Bürger

The main fire station in Regensburg impressively demonstrates that functional buildings with high architectural quality can also be realized. There, a particular strength of AGROB BUCHTAL came in useful: the comprehensive range includes numerous ceramic solutions for interior and exterior use – an advantage which enables holistic concepts.





The main fire station forms a large inner city building ensemble. A core element is the block visible from Greflingerstraße, which consists of three connected buildings which house, among other things, emergency vehicles and functional rooms. The right-hand section will remain, the middle section is to be extensively renovated in the next few years. The left-hand section consists of a new building which was put into operation in autumn 2019 and amazes both inside and out with its high design quality.

For the facade of this new building, the architects chose the system KeraTwin® from AGROB BUCHTAL with a differentiated color gradient of finely matched shades, which were specially developed and individually manufactured for this project. This graded color canon structures the functionally quite powerful building and makes it appear filigree and noble. The gentle rhythm of the facade is to be continued

in a coming construction phase at the already mentioned renovation of the middle section, so that a coherent structure will then be created, which captivates through homogeneity and materiality.

The high standards are continued inside in the sanitary and shower rooms, changing rooms, corridors, the canteen kitchen and the mudroom. There, too, ceramic tiles from AGROB BUCHTAL act as an architectural link and identity-forming elements: vivid color accents in yellow and red are in an exciting dialogue with neutralizing white and anthracite shades. In addition, all ceramic surfaces in the outdoor and indoor areas are provided with the photocatalytic Hytect surface.



KeraTwin®



Statement in New York

One of the special features of this building on Broadway, designed by Skidmore, Owings and Merrill (SOM), are the up to 250 m² luxury flats. The finely structured facade surfaces with matt black ceramics are also unique. Because thanks to them, the 64 metres high residential building blends into the architectural context with both self-confidence and respect.





KeraTwin®



Living is very popular in downtown Manhattan. Perhaps the hippest district is the former industrial quarter of Tribeca. One of the most exciting projects there is the "91 Leonard", which was completed in 2019. 19 storeys high and with a total of 16,500 m², it was built according to the plans of the New York architecture firm SOM, which was also responsible for the construction of the One World Trade Center.

"Our primary design goal was to create a building which relates to and respects the surrounding historic urban structure, while at the same time providing a modern addition to the quarter", says SOM Director Kim Van Holsbeke. This has been achieved through a finely structured facade with large windows – a reference to the old warehouse buildings and lofts with brick and natural stone facades in the neighbourhood. Regularly placed double windows are framed by a grid structure of square ceramic rectangular tubes from the KeraShape® system. The areas between this grid structure and the recessed window openings consist of facade tiles of the rear-ventilated ceramic facade system KeraTwin® K20. In this way, a picture rich in details and contrast is created. The elegant, matt black glaze of the ceramics creates a respectful interaction with neighbouring buildings – quasi as a contemporary interpretation of the typical Tribeca materials cast iron and stone.

If one stands in the spacious lobby, the fine furniture and the extensive glazing with a view of the leafy inner courtyard reveal that luxury is at home here – just as in the flats between 50 and 250 m² in size, on the roof terrace, in the cinema hall or in the spa area. Already from the outside, the facade designed with great precision and handcrafted sensuality also makes it clear that a special building has been created here.



91 Leonard Street / Architect: Skidmore, Owings & Merrill (SOM) & Hill West Architects / Year: 2019 / Products: KeraTwin® K20
Photos: Rich Earl Photography



Toll Brothers
CITY LIVING®

The company offering terms are an offering and available from The Sponsor, E/O N/A. CCB-1008



Earthy and airy

Rachel Haugh, one of the name-givers of SimpsonHaugh, has noted that there are two vital requirements for the design of a high-rise. One is to ensure it is well-connected on street level, and the other that it adds something to the skyline.



Downing Students City Village, Belgrade Plaza, Coventry, Great Britain / Architects: Simpson Haugh and partners group / Year: 2017
Products: KeraTwin® (K20) / Photos: Simon Hadley

This might be true in general, but in the case of the 20-storey complex of Belgrade Plaza in Coventry, it is equally important what happens architecturally in between the bottom and the top. The complex Haugh and Ian Simpson designed as part of the urban regeneration of the area near the Belgrade Theatre is situated in the northwestern part of the centre of Coventry. The city has endured a massive destruction during the Second World War and has subsequently been rebuilt in the 1950s and 60s in a tepid, reconciliatory style, combining concrete and brick. The Belgrade Plaza complex contains retail space on street level, 49 apartments and a variety of different types of housing for 600 students.

This complex obviously stands out due to its height in a predominantly low-rise cityscape, which is determined by the elevated ring road and the postwar reconstruction architecture of the centre of Coventry itself. In the direct surroundings of Belgrade Plaza there is not only the theatre but also some scattered detached and semi-detached housing that has survived the bombing in the 1940s. Simpson and Haugh have managed to blend in their intervention in this rather disparate mix of buildings that forms the context they had to work in, and with. To mitigate the change of scale imposed by the high-rise, the foot of the tower consists of additional low- and mid-rise volumes, with a gridded pattern to further break up their mass. The facades of these lower volumes are clad with KeraTwin® facade ceramics of AGROB BUCHTAL in earthy shades, harmonizing with the brick buildings in the area. The tower is finished in light-blue, glazed terra-cotta tiles with a glossy coating. The effect of these light-hued ceramics and their reflective finish is that it makes the tower appear lighter, and lighting it up, adding a welcome brightness to Coventry.



The cladding of the projections attributing the facade its characteristic structure required special customized production. Hence, AGROB BUCHTAL not only designed special panels and cross-sections: assembly was also based on an individual and detailed solution featuring a combination of K20 clamps and K20 system profiles. Based on detailed drawings, the arrow-shaped panels for the intersections were cut precisely in the factory in various sizes.



KeraTwin®

“Housing mountain”: ecological, social, radical



On the edge of the city centre of Rennes, a new imposing "mountain landscape" has been realized in the capital of Brittany. Three residential buildings, designed according to the four pillars of the sustainability strategy of the architecture office MVRDV, rise like rock formations from the natural environment. The ceramic shell from AGROB BUCHTAL perfectly translates the impression of a mountain range for Ilot de l'Octroi – today known as Ascension Paysagère – and appears as a striking silhouette of a landscape from the viewpoint of Rennes.





The Ascension Paysagère marks both the end point of an urban axis which originates in the centre of Rennes and the beginning of the inner city. On the last inner-city natural space, three buildings, developed according to passive house standards, give 136 flats a new address.

The heart of the quarter is a public square, which is connected to the long bank by steps and invites people to get together with a view of the adjacent floating garden, the Jardin de Confluence. In dialogue with the existing buildings, a place of cultural life is created which connects the location with its history.

Nature invites itself into the Ilot de l'Octroi residential complex on various levels. It is evident in the idea of integrating a coherent, defined volume of buildings in the urban environment instead of smaller units, and is reflected in the varied greening of the stepped and terraced signal buildings. Vertical openings reinforce the resulting height and make the ensemble stand out already from a distance. Only the thousands and thousands of vertically mounted panels of the KeraTwin® ceramic system from AGROB BUCHTAL complete the building concept. From a distance, the cubature develops into the image of an imposing mountain range, criss-crossed by alpine meadows and glacier fields.

A color gradient from grey to white and the texture from matt to glossy convey the peak impression from the ground. The exterior facades curve and the interior facades are cut to provide as many terraces as possible. No problem for the ceramic facade system, which has proved itself in both horizontal and vertical panel installation. Another competence of the building envelope: as an ecological building material, ceramics has a cooling effect in the quarter.

The conscious use of green resources and the urban planning concept to promote social coexistence are intended to serve as a model for the entire metropolitan region. The signal effect of Ascension Paysagère will therefore go far beyond the imposing silhouette which is visible from Rennes, especially at nightfall.



Ilot de l'Octroi, Rennes, France / Architect: MVRDV
Year: 2022 / Products: KeraTwin® (K20) / Photos: Ossip Architectuurfotografie

Ceramic facade systems for sustainable renovation

The world-wide trend towards urbanization is unbroken. New city dwellers need housing space, but areas for new buildings are hardly available today. That is why densification and modernization have been gaining importance for years. In this situation, ceramic facade systems offer decisive advantages.

The renovation of existing buildings opens up new opportunities for future-oriented urban planning: previously neglected urban districts are becoming attractive living areas, and after energy-efficient renovation, even historical buildings meet the increased demands made on the energy balance. For this reason, the renovations already exceed the volume of new buildings in many places. A sustainable solution with energy-efficient and aesthetic advantages is offered by ceramic facade systems, which are applied to the old facade like a second shell. In this way, diverse energy-saving requirements can be met, because the gap between the old and the new facade provides space for insulation layers of any thickness. In addition, curtain-type facades create ideal conditions for the visual enhancement of buildings, because they also allow a building grid which is independent of the original building fabric. And the positive effects on the quality of living also speak for this form of renovation. Because the decoupling of the outer skin from the building body keeps the living spaces cool in summer and warm in winter.



Edificio Albia, Bilbao, Spain / Architect: Estudio de Arquitectura y Urbanismo SG2A, Bilbao, Spain / Product: KeraTwin® / Photo: Lorenzo Rimondi



Residential building c/Juan Bautista Uribarri, Bilbao, Spain / Year: 2015 / Product: KeraTwin®



before



afterwards

Pharmacy Sciarretta, Castellirri, Italy / Architect: Stefano Russo / Product: KeraTwin® / Photo: Lorenzo Rimondi



before



nachher

San Ignacio 8, Durango (Vizcaya), Spain / Architect: Maab Arquitectura, Bilbao, Spain / Product: KeraTwin® / Photo: Joaquin Prat



before



afterwards

Puerto Ventana, Gijon, Spain / Product: KeraTwin® / Photo: Joaquin Prat



Surfaces, colors and formats for KeraTwin®

The KeraTwin® system offers additional options in terms of surface finish. In addition to the glossy, silky-matt or unglazed surfaces, panels are now also available which benefit from the technical possibilities offered by digital printing in order to create even more natural and lively facade areas or to achieve highlights.

For example, stone or wood looks can be realized which intimate great depth while this method sees the advantages of ceramics as a material being retained in full. The same also applies to the metallic surface finishes which open up incredible design options for ceramic facades.

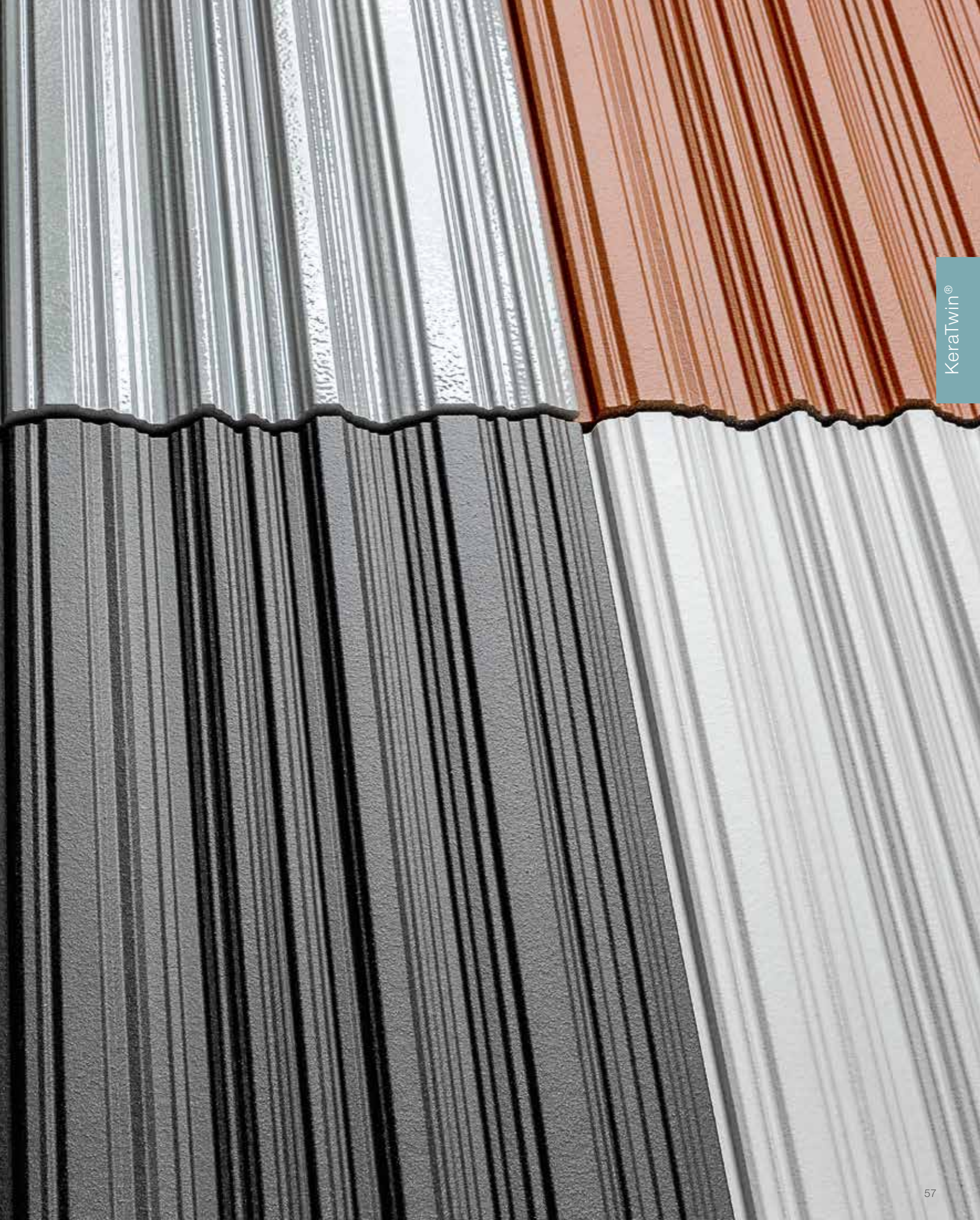

KeraTwin® K20



Smooth
(Standard)



Grooved panel
(cross-section 1)



Grooved panel positive
(cross-section 2)



Stripy pattern
(cross-section 3)



Shed profile
(cross-section 4)



Brushed surface
(cross-section 5)



Sine wave
(cross-section 6)



New Wave
(cross-section 7)



Panel with irregular grooves
(cross-section 8)



Canyon



Kaijo



KeraTwin® “Extruded Ceramic Panels, Precision, with an average water absorption of $3\% < E \leq 6\%$, group Alla, part 1, annex B, glazed (GL) and unglazed (UGL)”

KeraTwin® “Extruded Ceramic Panels, Precision, with an average water absorption of $6\% < E \leq 10\%$, group Allb, part 1, annex D, glazed (GL) and unglazed (UGL)”

Lengths of up to 1,800 mm (in 1 mm steps)

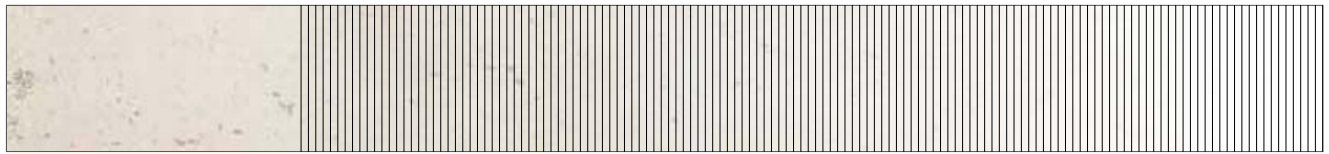

Length of up to 900 mm	up to 1,200 mm	up to 1,500 mm	up to 1,800 mm
Height 150 mm 175 mm 	200 mm 225 mm 	250 mm 275 mm 	300 mm 325 mm 350 mm 375 mm 400 mm 450 mm 500 mm 550 mm 600 mm

Schematic diagram: production-related deviations possible in individual cases; exact panel cross-section on request.

In addition to the variants shown, other, individual developments are possible on request.

The technical realization of the color design partly depends on the cross-section geometry. We will check this on request.

Due to the different panel cross-sections, the choice of the fastening system depends on the individual case. Furthermore, color deviations compared to the standard variants can not be excluded.

For technical reasons of production, smooth KeraTwin® panels may have slight undulations or stripes.

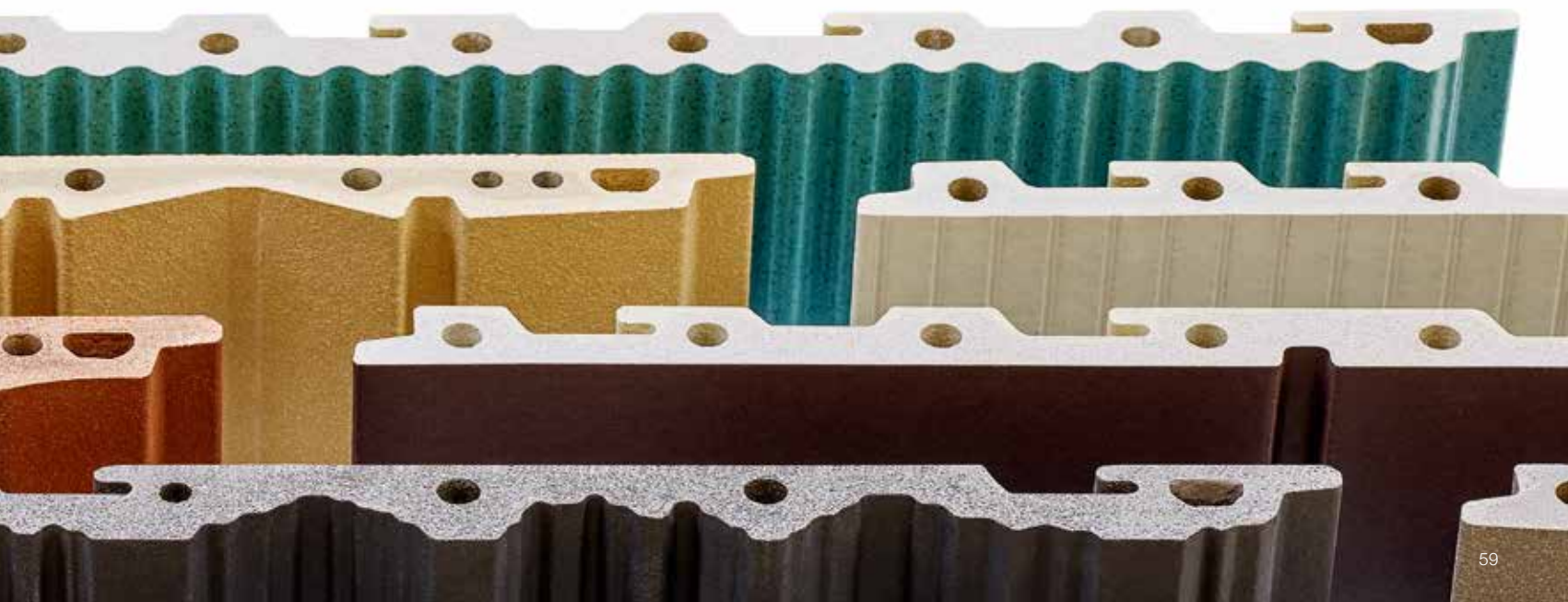

SpectraView glazed, silky-matt

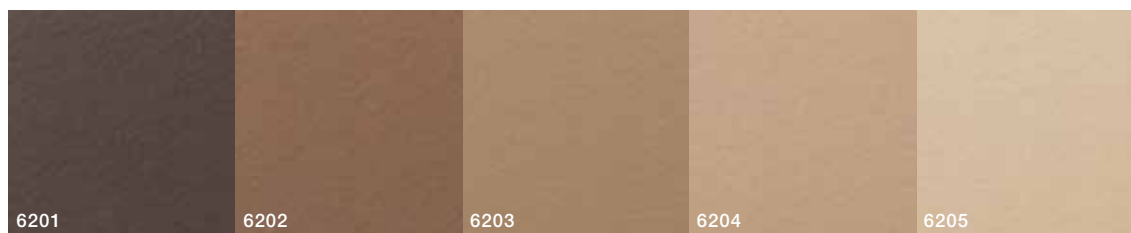

6201 cream 1 H 6202 cream 2 H 6203 cream 3 H 6204 cream 4 H 6205 cream 5 H

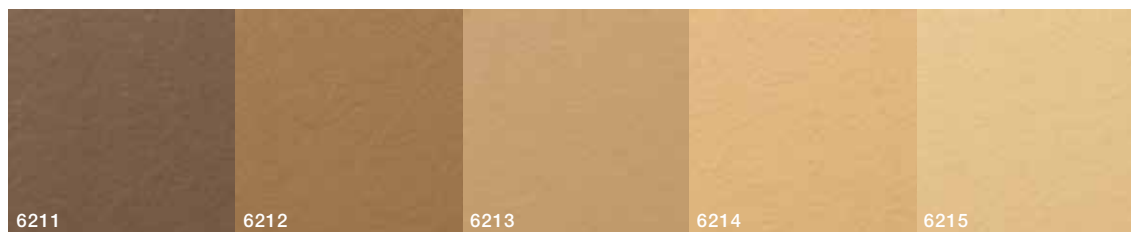

6211 yellow 1 H 6212 yellow 2 H 6213 yellow 3 H 6214 yellow 4 H 6215 yellow 5 H

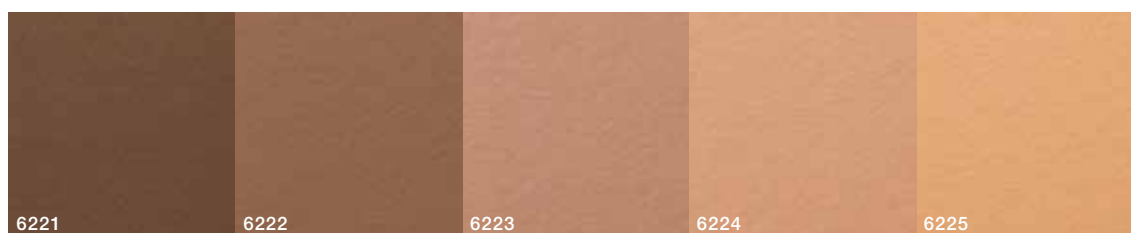

6221 apricot 1 H 6222 apricot 2 H 6223 apricot 3 H 6224 apricot 4 H 6225 apricot 5 H

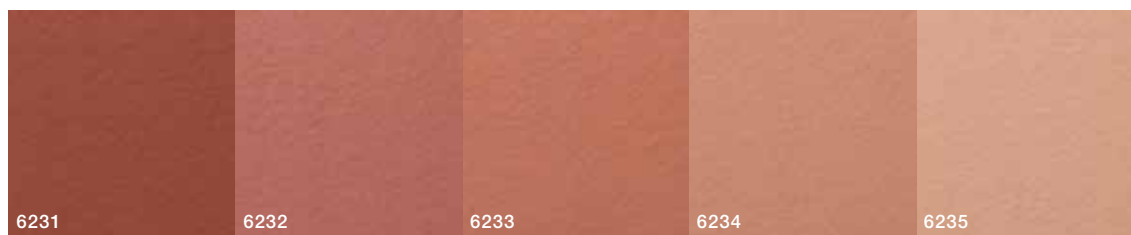

6231 salmon-red 1 H 6232 salmon-red 2 H 6233 salmon-red 3 H 6234 salmon-red 4 H 6235 salmon-red 5 H

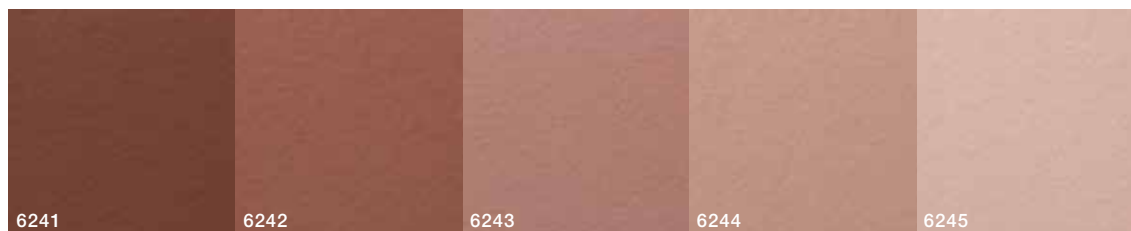

6241 pink 1 H 6242 pink 2 H 6243 pink 3 H 6244 pink 4 H 6245 pink 5 H



H = Hytect surface

In addition to the variants shown, the production of individual articles is also possible. After a short check of the individual case for technical and economical feasibility, we will be pleased to provide you with project-specific information.

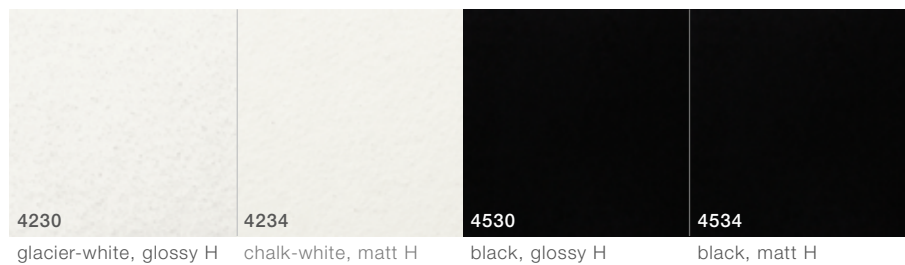

Contrasting colors glazed, glossy

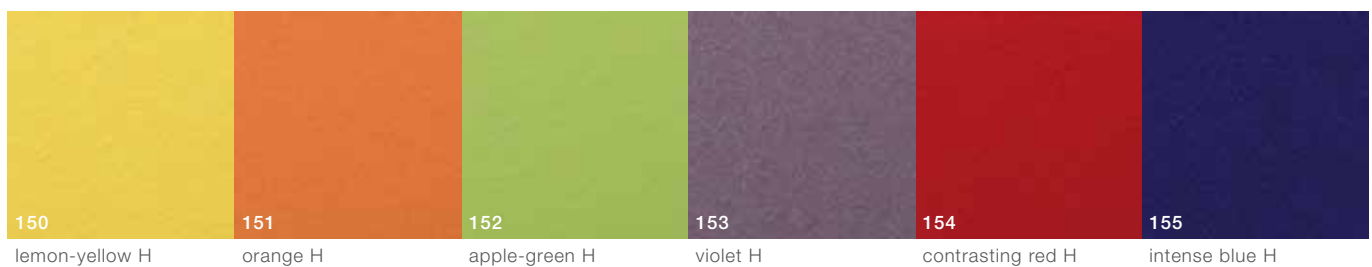

Design glazed

Stone

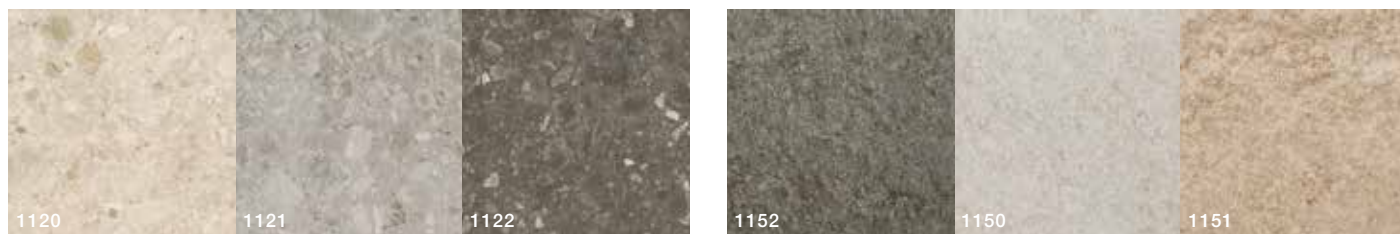

1120

Milan beige H

1121

Milan grey H

1122

Milan anthracite H

1152

Quarzit basalt-grey H

1150

Quarzit white-grey H

1151

Quarzit sand-beige H

1115

Rockface 1 H

1116

Rockface 2 H

1117

Rockface 3 H

1110

Mega 1 H

1111

Mega 2 H

1112

Mega 3 H

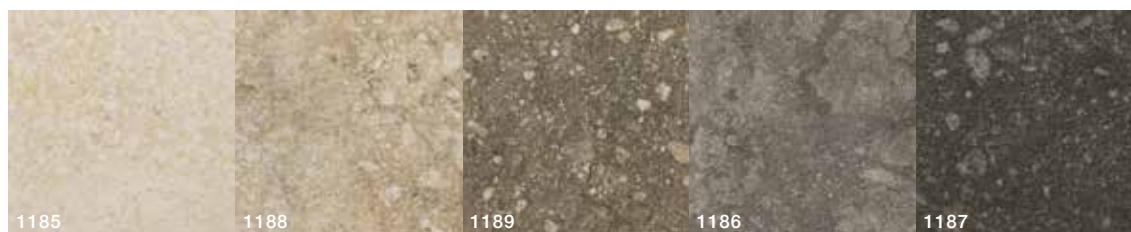

1185

Savona lime H

1188

Savona beige H

1189

Savona brown H

1186

Savona grey H

1187

Savona anthracite H



1090

Haze 1 H

1091

Haze 2 H

1093

Haze 3 H

1092

Haze 4 H



1100

Stonewall 1 H

1101

Stonewall 2 H

1102

Stonewall 3 H

1103

Stonewall 4 H

Cement

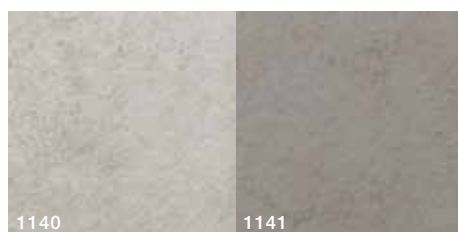

1140

Construct 1 H

1141

Construct 2 H

Metal



Wood

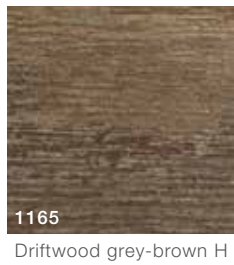
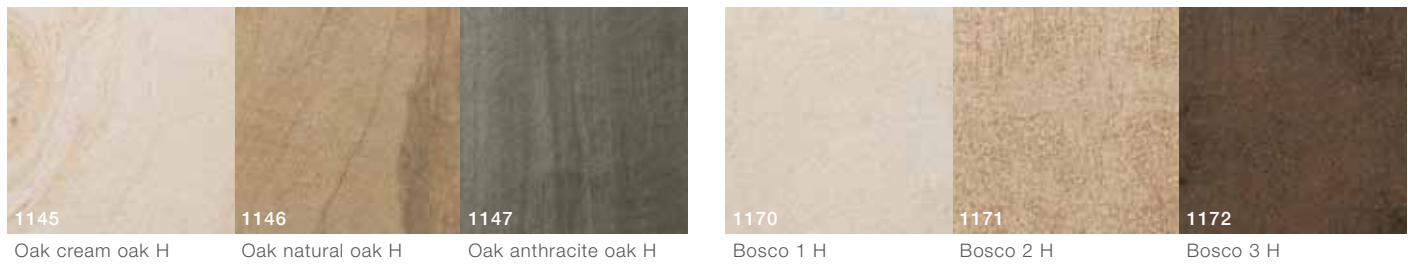

Design unglazed



H = Hytect surface

In addition to the variants shown, the production of individual articles is also possible. After a short check of the individual case for technical and economical feasibility, we will be pleased to provide you with project-specific information.

Natura unglazed

				
407 white white H	410 cream cream H	411 ochre ochre H	412 salmon salmon H	396 salmon-red salmon-red H
				
403 red red H	397 brick-red brick-red H	408 red-brown red-brown H	418 brown brown H	414 light-grey light-grey H
				
409 iron-grey iron-grey H	415 N vulcan-grey vulcan-grey H	419 black black H	416 smoky-blue smoky-blue H	417 patina-green patina-green H



H = Hytect surface

In addition to the variants shown, the production of individual articles is also possible. After a short check of the individual case for technical and economical feasibility, we will be pleased to provide you with project-specific information.



KeraTwin®

KeraTwin® K20 – Fastening with vertical system rail K20

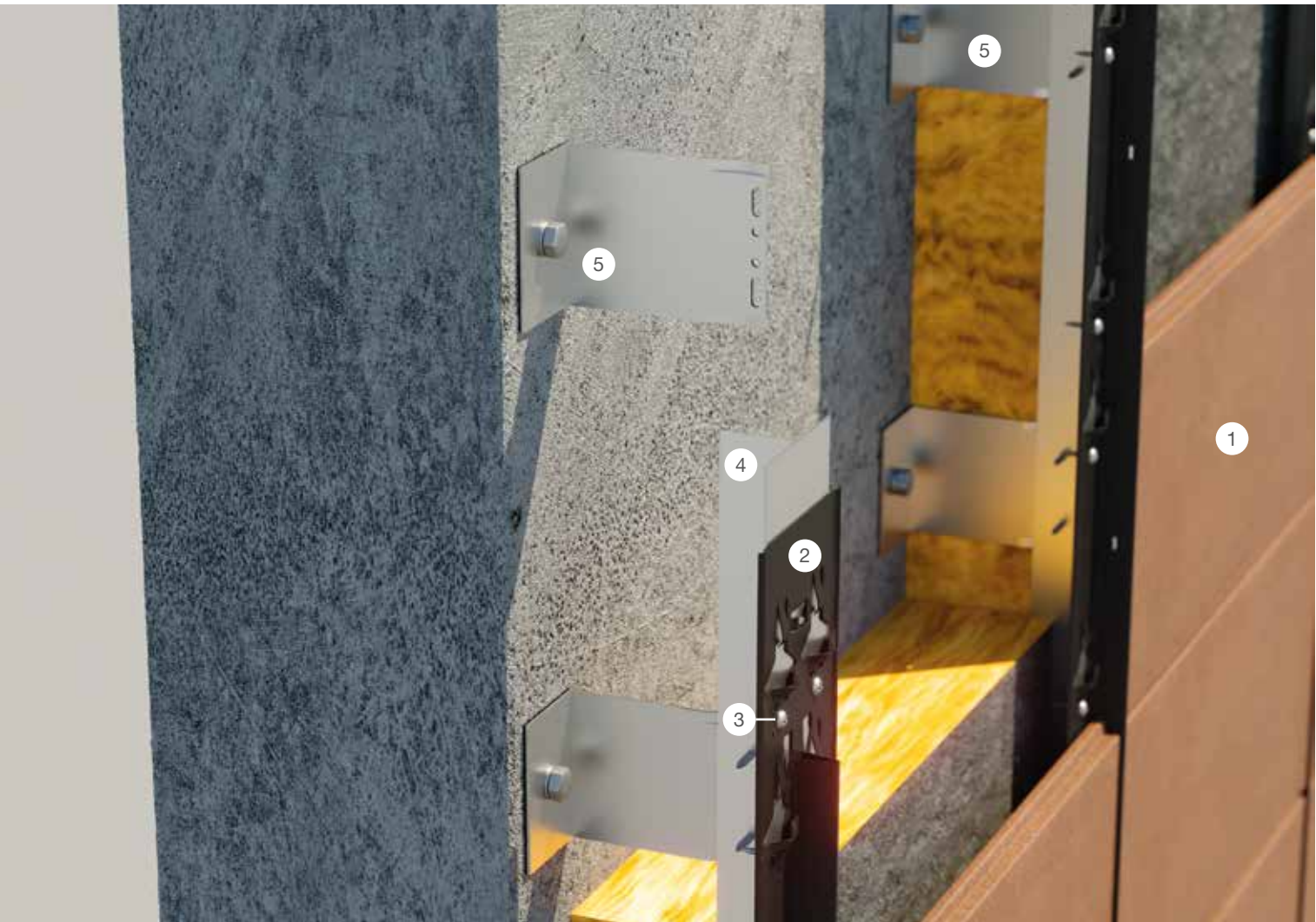

System description

The KeraTwin® K20 facade panels are simply hung in the vertical system rail with the holding grooves on the reverse side. For mounting the panels, no additional tools are required. The compression spring and removal protection integrated in the system rail prevents clattering and constraining forces in the case of alternating wind loads and also the easy removal of panels. The position of the panels is secured either by means of a joint profile adjusted to the joint width or by means of spacers.

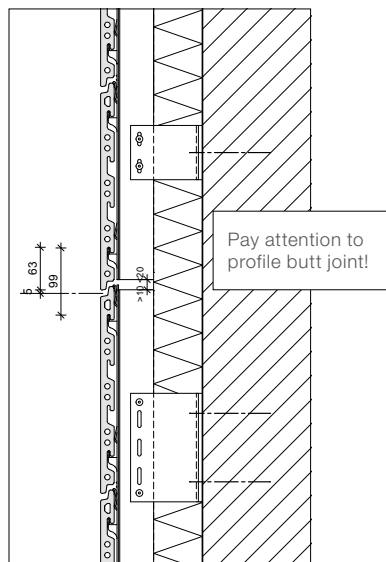

- 1 Facade panel KeraTwin® K20
- 2 Vertical system rail K20, article 620
- 3 A4 stainless steel screw, article 659-1 alternatively, fastening with Al blind rivet, article 658, is possible), fixing necessary under each fastening hook!
- 4 Vertical bearing profile (basic substructure) Minimum width 80 mm / recommended width 100 mm
- 5 Wall bracket (basic substructure)

! A profile butt joint of the vertical bearing profiles behind a panel is not allowed! See standard technical detail drawings.

Mounting instructions for KeraTwin® K20 – Fastening by means of vertical system rail K20



Mounting instructions as video film:
www.agrob-buchta.de

Substructure

The mounting of the substructure must be carried out according to project-specific, static calculation. The usability certification Z-10.3-844 serves as basis.

- The profiles of the basic substructure have to be mounted perpendicularly and in a flush way. (T-profile width ≥ 80 mm; recommended width ≥ 100 mm)
- The system rails K20 (Art. no. 620, 625, 630) have to be precisely aligned horizontally and fastened at the provided holes by means of screws (Art. no. 659-01) or rivets (Art. no. 658).
- The distance of the system rails K20 in horizontal direction must correspond to the longitudinal grid of the panels [L] or [L/2], depending on the static requirements.
- The length of the vertical profiles must be divisible by the height of the panel format and should not exceed the height of a storey of the building.
- A profile butt joint behind a panel is not allowed.
- In case of open vertical joints, one joint spacer per panel (Art. no. 645) is inserted in a centric extrusion hole of the panel.
- In case of closed vertical joints, the joint profile (Art. no. 640 in case of single-span girder; plug-in joint profile, Art. no. 647, in case of single-span girder with jibs) must be used



Basic substructure



Fasten system rail with Al blind rivet (Art. no. 658) or A4 stainless steel screw (Art. no. 659-01)



Click in the joint profile (for closed joints)



Hang in the KeraTwin® panel



Alternative to the joint profile: spacer, Art. no. 645 (for open joints)

Accessories: KeraTwin® K20 – Fastening with vertical system rail K20

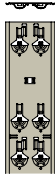

Article 620
System rail, painted*
Material: AlMg3 H22
(EN AW-5754),
painted black, for installation
with joint spacer K20/8



Article 625
System rail, bright*
Material: AlMg3 H22
(EN AW-5754),
unpainted, for installation
with joint profile K20/8

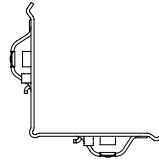

Article 630
System rail, external angle*
Material: AlMg3 H22
(EN AW-5754),
unpainted, for installation
of mitre-cut panels and
external angle profiles

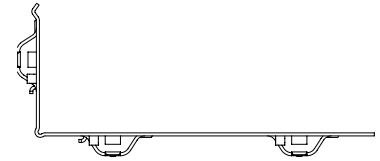

Article 635
Embrasure profile*
Material: AlMg3 H22
(EN AW-5754),
unpainted, dimensions and grid
according to project-specific
requirements

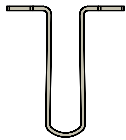

Article 640
Joint profile K20/8
Material: AlMg3 H22
(EN AW-5754),
painted black,
RAL 7021,
RAL-color-painted on
request.

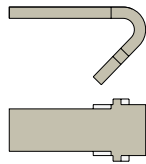

Article 645
Joint spacer K20/8
Weight: 0.5 kg / box
Material: AlMg3 H22
(EN AW-5754)
Box contents: 250 pieces
painted black,
RAL 7021



Article 658
Al blind rivet, bright
Weight: 1.3 kg / box
Nominal dimensions: 4.8 x 10 mm
Box contents: 500 pieces
for system rail installation



Article 659-01
A4 stainless steel screw, bright
Weight: 2.8 kg / box
Nominal dimensions: 4.8 x 16 mm
Box contents: 500 pieces + 1 bit
for system rail installation

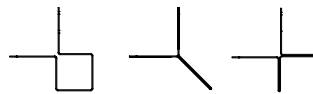

Article 650 / 652 / 654
External angle profile Square /
Sword / Negative
Material: AlMg3 H22
(EN AW-5754),
painted black,
RAL 7021
RAL-color-painted
on request.

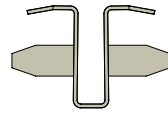

Article 647
Plug-in joint profile K20/8
Material: AlMg3 H22
(EN AW-5754)
painted black,
RAL 7021,
RAL-color-painted on request.
For installation in case of
single-span girder with jibs
Length: 1496 mm

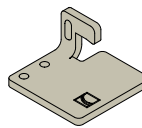

Article 682R
R-clamp
Material: AlMg3 H22
(EN AW-5754),
painted black

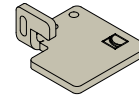

Article 683R
R-clamp
Material: AlMg3 H22
(EN AW-5754),
painted black

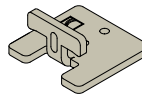

Article 684R
R-clamp
Material: AlMg3 H22
(EN AW-5754),
painted black



Article 657
A2 stainless steel screw,
black head,
RAL 7021, for fastening
of R-clamp

* legally protected

Profile lengths available: Grid of 15 cm, 60 cm: 2992 mm
Grid of 17.5 cm: 2967 mm · Grid of 20 cm, 25 cm, 30 cm, 37.5 cm, 50 cm: 2992 mm
Grid of 22.5 cm, 32.5 cm: 2917 mm · Grid of 27.5 cm, 55 cm: 2742 mm
Grid of 35 cm, 40 cm: 2792 mm

System profile K20 available for panel grids of 15 cm – 17.5 cm – 20 cm – 22.5 cm
– 25 cm – 27.5 cm – 30 cm – 32.5 cm – 35 cm – 37.5 cm – 40 cm – 45 cm –
50 cm – 55 cm – 60 cm. Other grids on request.

Important: The use of silicone caoutchoucs must be absolutely avoided, because silicone fluids segregate and effect sticky surfaces on which dirt adheres. Therefore, only use the system components mentioned (foamed pieces, EDPM rubber profile, neoprene rubber washer) and pointing, bonding and sealing materials recommended by us. We will be pleased to inform you in detail. The usual final cleaning after completion of the construction works is still required. A warranty for the system KeraTwin® K20 in the scope of the usability certification Z-10.3-844 only applies if the system components shown on these pages are used.



Medical day care unit ZfP Südwürttemberg, Biberach, Germany
Architect: Die Ulmer Architekten BDA / Year: 2020 / Photo: Conné Van D'Grachten



Edificio Zafiro, Ripagaina, Spain / Architect: Tabuenca y Saiategui Arquitectos / Year: 2019 / Photo: Joaquin Prat



Sstart-up centre "Einstein 1" at the campus of HAW Hof, Germany / Architect: Architektur GmbH (Renee Lorenz) / Year: 2019 / Photo: Vanessa Wagner



Orangerie de Soussie, Morocco / Architect: JLA Studio
Year: 2016 / Photo: Sife Elamine

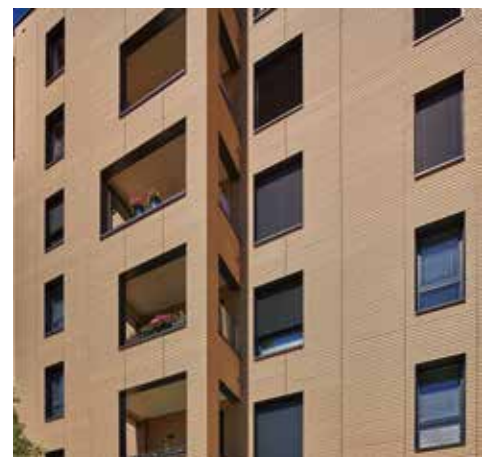

Housing complex "Preyer'sche Höfe", Vienna, Austria
Architect: Albert Wimmer ZT-GmbH until submission together with BWM Architekten / sk stadtplanung & architektur / Year: 2020 / Photo: Peters Fotodesign

KeraTwin® K20 – Fastening with vertical T-profile K20

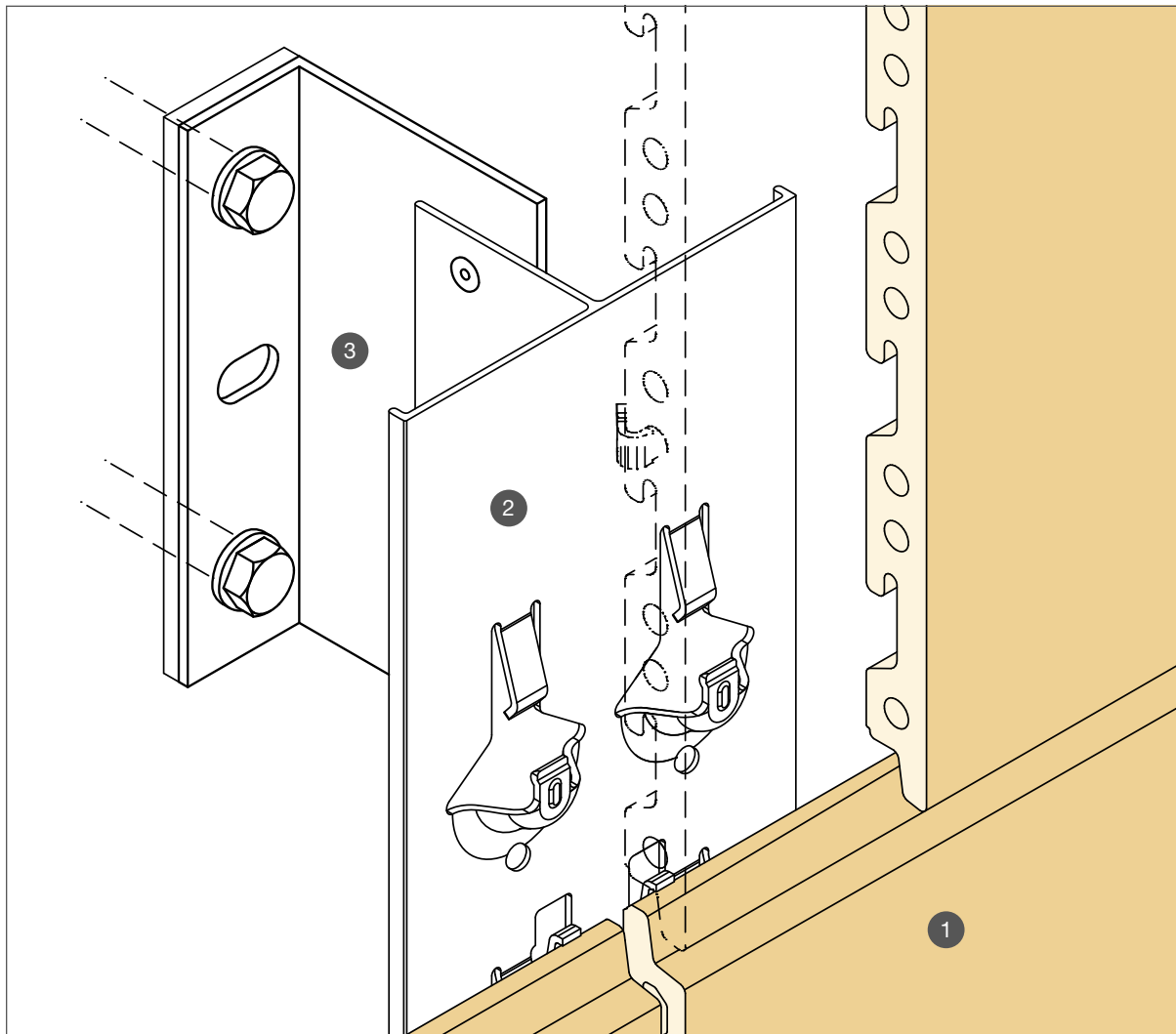

System description

The KeraTwin® K20 facade panels are simply hung in the vertical T-profile K20 with the holding grooves on the reverse side. For mounting the panels, no additional tools are required. The compression spring and removal protection integrated in the T-profile K20 prevents clattering and constraining forces in the case of alternating wind loads and also the easy removal of panels. The position of the panels is secured either by means of a joint profile adjusted to the joint width or by means of spacers for closed or open vertical joints.

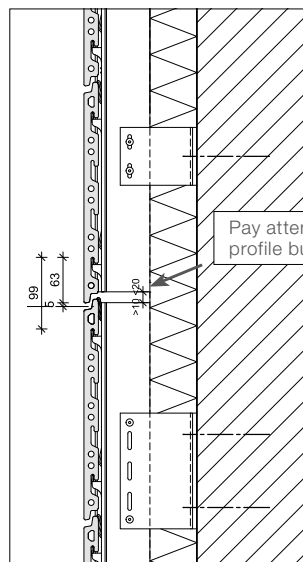

- 1 Facade panel KeraTwin® K20
- 2 Vertical T-profile K20, article 695Q
- 3 Wall bracket (basic substructure)

!
A profile butt joint of the vertical bearing profiles behind a panel is not allowed! See standard technical detail drawings.

Mounting instructions for KeraTwin® K20 – Fastening by means of vertical T-profile K20



Mounting instructions as video film:
www.agrob-buchta.de

Substructure

The mounting of the substructure must be carried out according to project-specific, static calculation. The usability certification Z-10.3-844 serves as basis.

- Mount the T-profiles K20 (Art. no. 695) perpendicularly and in a flush way.
- The distance of the T-profiles K20 in horizontal direction must correspond to the longitudinal grid of the panels [L] or [L/2], depending on the static requirements.
- Exactly align the T-profiles K20 horizontally.
- Open vertical joints with T-profile K20 (Art. no. 695Q) with spacer (Art. no. 645).
- In case of closed vertical joints, the joint profile (Art. no. 640Q in case of single-span girder, plug-in joint profile, Art. no. 647, in case of single-span girder with jibs) must be used.



Basic substructure



Mount the T-profile with approved fastening means



Hang in the KeraTwin® panels



Alternative to T-profile with joint profile: spacer, Art. no. 645 (for open joints)

Accessories: KeraTwin® K20 – Fastening by means of vertical T-profile K20

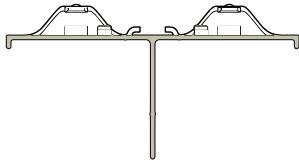

Article 695Q
T-profile K20*
Material: EN AW-6060 T6
anodized C35,
RAL 7021, for installation
with joint profile 640Q and
joint spacer K20/8

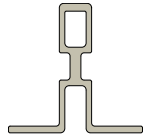

Article 640Q
Joint profile
Material: EN AW-6063 T66,
painted black,
RAL 7021

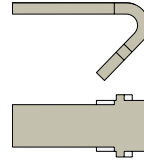

Article 645
Joint spacer K20/8
Weight: 0.5 kg / box
Material: AlMg3 H22
(EN AW-5754)
Box contents: 250 pieces
painted black,
RAL 7021

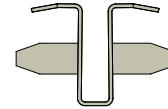

Article 647
Plug-in joint profile K20/8
Material: AlMg3 H22
(EN AW-5754)
painted black, RAL 7021,
RAL-color-painted on request.
For installation in case of
single-span girder with jibs.
Length: 1496 mm

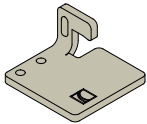

Article 682R
R-clamp
Material: AlMg3 H22
(EN AW-5754),
painted black

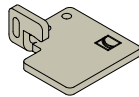

Article 683R
R-clamp
Material: AlMg3 H22
(EN AW-5754),
painted black

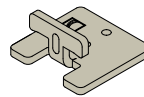

Article 684R
R-clamp
Material: AlMg3 H22
(EN AW-5754),
painted black



Article 657
A2 stainless steel screw,
black head,
RAL 7021, for fastening
of R-clamp

* legally protected

Profile lengths available: Grid of 60 cm: 2992 mm · Grid of 17.5 cm: 2967 mm
Grid of 20 cm, 25 cm, 30 cm, 37.5 cm, 50 cm: 2992 mm · Grid of 22.5 cm,
32.5 cm: 2917 mm, Grid of 27.5 cm, 55 cm: 2742 mm · Grid of 35 cm, 40 cm: 2792 mm

T-profile K20 available for panel grids of 17.5 cm – 20 cm – 22.5 cm –
25 cm – 27.5 cm – 30 cm – 32.5 cm – 35 cm – 37.5 cm – 40 cm – 45 cm –
50 cm – 55 cm – 60 cm. Other grids on request.

Important: The use of silicone caoutchoucs must be absolutely avoided, because silicone fluids segregate and effect sticky surfaces on which dirt adheres. Therefore, only use the system components mentioned (foamed pieces, EDPM rubber profile, neoprene rubber washer) and pointing, bonding and sealing materials recommended by us. We will be pleased to inform you in detail. The usual final cleaning after completion of the construction works is still required. A warranty for the system KeraTwin® K20 in the scope of the general approval no. Z-33.1-1175 of the construction supervisory authority only applies if the system components shown on these pages are used



Apartment complex The Viridian, Boston, USA / Architect: Bruner/Cott & Associates, Cambridge / Year: 2015 / Photo: Fred Clements, cb-products



Calle Tomas Zubiria Ybarra nº 1 (Panera 2), Bilbao, Spain
Architect: Studio VAID ARQUITECTURA / Architect Virginia Mugica
Year: 2019 / Photo: Studio VAID ARQUITECTURA



Can Serras Department Stores, Granollers, Spain
Architect: Aquidos Arquitectes / Year: 2019 / Photo: Adrià Goula



Riomer University, Vilnius, Lithuania / Architect: Arch. Irmantas Gudavičius Statybos projektu valdymas / Year: 2015
Photo: Nedas Bobinas, cb-products



Registered office CR PROJECT SERVICE S.R.L., Viterbo, Italy
Architect: NOU SFERA LAB / Year: 2020 / Photo: Andrea Pietroni, VM Group

KeraTwin® K20 – Fastening with vertical Omega profile K20



System description

The Omega profile stands out due to its simple and efficient installation on bases other than brickwork, such as e.g. walls with post and beam construction. Horizontal bearing profiles are fixed at the posts. The vertical Omega profiles can then be arranged independent of the distance between the posts, and the panel lengths can be freely planned. The complex system structure with dowel, wall bracket and vertical bearing profile is not required. The subsequent laying of the ceramics is carried out as in the case of the system rail K20. The KeraTwin® K20 facade panels are simply hung in the vertical Omega profile with the holding grooves on the reverse side. No additional tools are required for mounting the panels. The compression spring and removal protection integrated in the Omega profile prevents clattering and constraining forces in the case of alternating wind loads and also the easy removal of panels. The position of the panels is secured either by means of a joint profile adjusted to the joint width or by means of spacers.

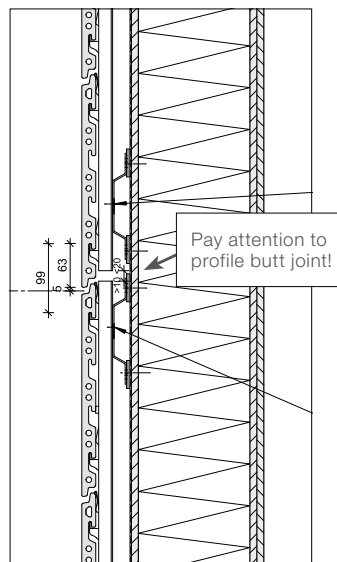

- 1 Facade panel KeraTwin® K20
- 2 Vertical Omega profile K20, article 624
- 3 A4 stainless steel screw, article 659-01 (alternatively, fastening with Al blind rivet, article 658, is possible)
- 4 Horizontal bearing profile (basic substructure)

!
A profile butt joint of the vertical bearing profiles behind a panel is not allowed! See standard technical detail drawings.

Mounting instructions for KeraTwin® K20 – Fastening by means of vertical Omega profile K20



Mounting instructions as video film:
www.agrob-buchta.de

Substructure

The mounting of the substructure must be carried out according to project-specific, static calculation. The usability certification Z-10.3-844 serves as basis.

- The profiles of the basic substructure have to be mounted perpendicularly and in a flush way (top-hat or alternatively Z-profile).
- The Omega profiles K20 (Art. no. 624, 627, 633) have to be precisely aligned horizontally and be fixed through the long holes provided on the edge by means of appropriate fasteners such as e.g. screws (Art. no. 659-01) or rivets (Art. no. 658). (Pay attention to fixed and sliding point execution!).
- The distance of the system rails K20 in horizontal direction must correspond to the longitudinal grid of the panels [L] or [L/2], depending on the static requirements.
- A profile butt joint behind a panel is not allowed.
- In case of open vertical joints, one joint spacer per panel (Art. no. 645) is inserted in a centric extrusion hole of the panel.
- In case of closed vertical joints, the joint profile (Art. no. 640 in case of single-span girder; plug-in joint profile, Art. no. 647, in case of single-span girder with jibs) must be used.



Basic substructure



Fasten Omega profile with Al blind rivet (Art. no. 658) or A4 stainless steel screw (Art. no. 659) (Pay attention to fixed and sliding point)



Click in the joint profile (for closed joints)



Hang in the KeraTwin® panels

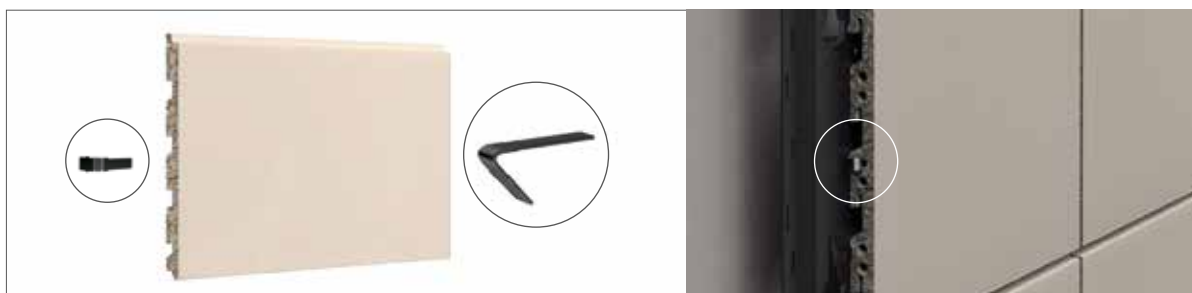

Alternative to the joint profile: spacer, Art. no. 645 (for open joints)

Accessories: KeraTwin® K20 – Fastening by means of vertical Omega profile K20

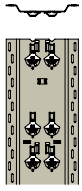

Article 624
Omega profile, painted*
Material: AlMg3 H22
(EN AW-5754),
painted black, RAL 7021,
for installation
with joint spacer K20/8

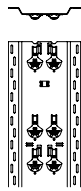

Article 627
Omega profile, bright*
Material: AlMg3 H22
(EN AW-5754),
unpainted, for installation
with joint profile K20/8



Article 633
Omega profile, external angle*
Material: AlMg3 H22
(EN AW-5754),
unpainted, for the installation of
mitre-cut panels and external
angle profiles



Article 658
Al blind rivet, bright
Weight: 1.3 kg / box
Nominal dimensions: 4.8 x 10 mm
Box contents: 500 pieces
for Omega profile installation



Article 659-01
A4 stainless steel screw, bright
Weight: 2.8 kg / box
Nominal dimensions: 4.8 x 16 mm
Box contents: 500 pieces + 1 bit
for Omega profile installation

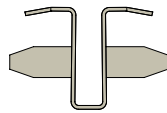

Article 647
Plug-in joint profile K20/8
Material: AlMg3 H22
(EN AW-5754)
painted black, RAL 7021,
RAL-color-painted on request,
for installation in case of
single-span girder with jib
Length: 1496 mm

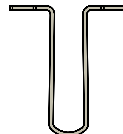

Article 640
Joint profile K20/8
Material: AlMg3 H22
(EN AW-5754),
painted black, RAL 7021,
RAL-color-painted on request

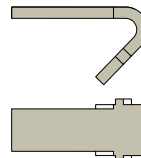

Article 645
Joint spacer K20/8
Weight: 0.5 kg / box
Material: AlMg3 H22
(EN AW-5754)
Box contents: 250 pieces
painted black, RAL 7021

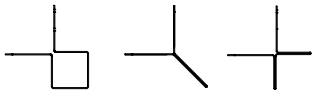

Article 650 / 652 / 654
External angle profile
Square / Sword / Negative
Material: AlMg3 H22
(EN AW-5754),
painted black, RAL 7021,
RAL-color-painted on request

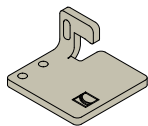

Article 682R
R-clamp
Material: AlMg3 H22
(EN AW-5754),
painted black

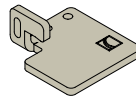

Article 683R
R-clamp
Material: AlMg3 H22
(EN AW-5754),
painted black



Article 657
A2 stainless steel screw,
black head,
RAL 7021, for fastening
of R-clamp

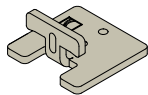

Article 684R
R-clamp
Material: AlMg3 H22
(EN AW-5754),
painted black

* legally protected

Profile lengths available: Grid of 15 cm, 60 cm: 2992 mm
Grid of 17.5 cm: 2967 mm · Grid of 20 cm, 25 cm, 30 cm, 37.5 cm, 50 cm: 2992 mm
Grid of 22.5 cm, 32.5 cm: 2917 mm · Grid of 27.5 cm, 55 cm: 2742 mm
Grid of 35 cm, 40 cm: 2792 mm

Omega profile K20 available for panel grids of 15 cm – 17.5 cm – 20 cm –
22.5 cm – 25 cm – 27.5 cm – 30 cm – 32.5 cm – 35 cm – 37.5 cm – 40 cm –
45 cm – 50 cm – 55 cm – 60 cm. Other grids on request.

Important: The use of silicone caoutchoucs must be absolutely avoided, because silicone fluids segregate and effect sticky surfaces on which dirt adheres. Therefore, only use the system components mentioned (foamed pieces, EDPM rubber profile, neoprene rubber washer) and pointing, bonding and sealing materials recommended by us. We will be pleased to inform you in detail. The usual final cleaning after completion of the construction works is still required. A warranty for the system KeraTwin® K20 in the scope of the general approval no. Z-33.1-1175 of the construction supervisory authority only applies if the system components shown on these pages are used.



Private villa, Romania / Architect: Victor Gota / Year: 2016



Raiffeisen Forum, Mödling, Austria / Architect: arge x42 / Year: 2014
Photo: Rich Hiebl



Edificio Residenziale Via degli Schiavoni, Fano, Italy / Architect: Studio Zandri Via de Borgogelli / Year: 2019 / Photo: VM Group



University, Bologna, Italy
Architect: Raffaele PANELLA
Year: 2015 / Photo: Lorenzo Rimondi



200 Old Colony Ave Apartments,
Boston, USA / Year: 2020
Photo: Gene Pawlikowski



SNAC, Southampton, Great Britain / Architect: CZWB Architects
Year: 2015 / Photo: Norbert Lindner

KeraTwin® K20 – Fastening with OmegaV profile for laying in bonds



System description

The OmegaV profile was developed to enable installation of KeraTwin® K20 panels in various bonds while availing of all of the advantages offered by the K20 system. The horizontal bearing profiles are fastened to a basic construction at the desired height grid. Then the OmegaV profiles can be hung from the horizontal bearing profiles and with the requisite spacing (length grid “L” or “L2”) before being secured to the two top suspension brackets using A4 stainless steel screws. The KeraTwin® K20 facade panels are simply hung in the preassembled OmegaV profiles using the holding grooves on the reverse side. No additional tools are required for mounting the panels. The compression spring integrated in the OmegaV profile prevents clattering and constraining forces in the case of alternating wind loads as well as the easy removal of panels. The position of the panels is secured either by means of a joint profile adjusted to the joint width or using spacers.

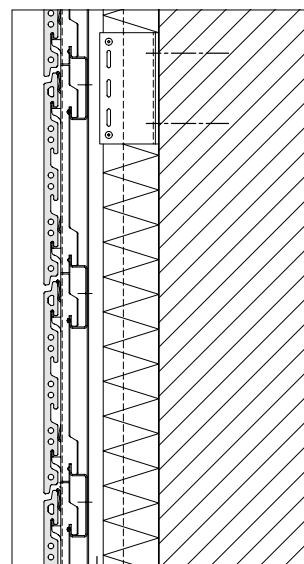

- 1 KeraTwin® K20 facade panel
- 2 OmegaV profile, Article 700
- 3 Horizontal supporting profile, Article 597-01
- 4 Vertical bearing profile (basic substructure)
- 5 Wall bracket (basic substructure)

System illustration

Mounting instructions for KeraTwin® K20 – with OmegaV for laying in bonds



Mounting instructions as video film:
www.agrob-buchta.de

Substructure

The mounting of the substructure must be carried out according to project-specific, static calculation. The general approval Z-10.3-844 of the construction supervisory authority serves as basis.

- The profiles of the basic substructure have to be mounted perpendicularly and in a flush way.
- Fix the horizontal supporting profiles (Art. no. 597-01) at the pre-installed vertical substructure by means of the supplied fastening materials.
- Hang in the OmegaV profiles exactly at horizontal grid distance.
- The distance of the K20 OmegaV profiles in horizontal direction must correspond to the longitudinal grid of the panels [L] or [L/2], depending on the static requirements.
- The position of the OmegaV profiles is secured at the suspension brackets on the left and the right by means of screws (Art. no. 659-01).
- In case of open vertical joints, one joint spacer per panel (Art. no. 645) is inserted in a centric extrusion hole of the panel.
- In case of closed vertical joints, the joint profile OmegaV (Art. no. 707) must be used.
- In case of single-span girder, the plug-in joint profile OmegaV (Art. no. 707 in case of single-span girder without jibs; Art. no. 712 in case of single-span girder with jibs) must be used.



Basic substructure with horizontal supporting profiles

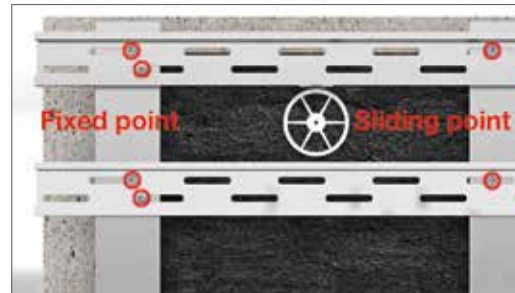

Fixed and sliding point execution



OmegaV profiles



Fixing of OmegaV profiles

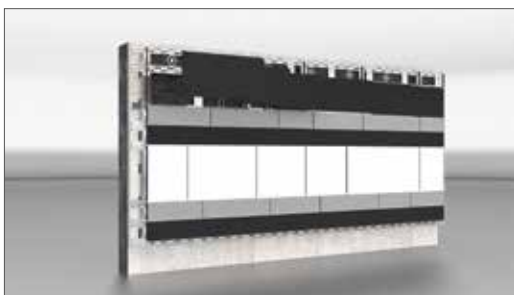

Panel mounting

Accessories: KeraTwin® K20 – OmegaV fastening on horizontal supporting profile

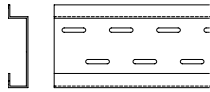

Article 597-01
Horizontal supporting profile,
perforated
Standard length: 2995 mm
Nominal dimensions: 05/90 x 25 mm
Material: EN AW 6063 T66
unpainted

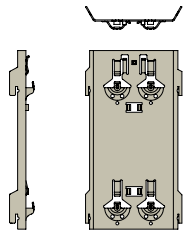

Article 700
OmegaV, painted*
RAL 7021,
Material: AlMg3 H22
(EN AW-5754)
painted black, for
installation
with joint spacer K20/8

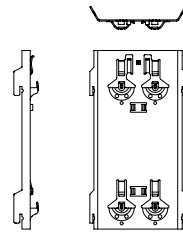

Article 701
OmegaV, bright*
Material: AlMg3 H22
(EN AW-5754)
unpainted, for installation
with joint profile OmegaV K20/8

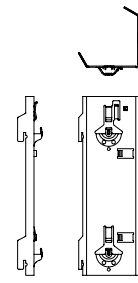

Article 705
OmegaV, external angle, bright*
Material: AlMg3 H22
(EN AW-5754)
unpainted, for the installation
of mitre-cut panels and external
angle profiles

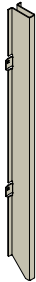

Article 707
Joint profile OmegaV K20/8
Material: AlMg3 H22
(EN AW-5754)
painted black,
RAL 7021,
RAL-color-painted on request

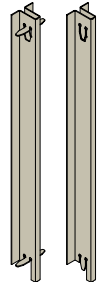

Article 712
Plug-in joint profile OmegaV K20/8
Material: AlMg3 H22
(EN AW-5754)
painted black, RAL 7021,
RAL-color-painted on request

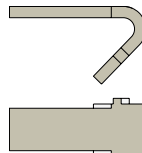

Article 645
Joint spacer K20/8
Weight: 0.5 kg/box
Material: AlMg3 H22
(EN AW-5754)
Box contents: 250 pieces
painted black,
RAL 7021



Article 658
Al blind rivet, bright
Weight: 1.3 kg / box
Nominal dimensions: 4.8 x 10 mm
Box contents: 500 pieces



Article 659-01
A4 stainless steel screw, bright
Weight: 1.4 kg/box
Nominal dimensions: 4.8 x 16 mm
Box contents: 500 pieces + 1 bit
for OmegaV fastening

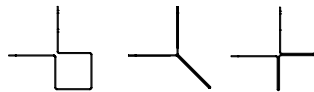

Article 650 / 652 / 654
External angle profile
Square / Sword / Negative
Material: AlMg3 H22
(EN AW-5754),
painted black,
RAL 7021,
RAL-color-painted on request

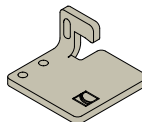

Article 682R
R-clamp
Material: AlMg3 H22
(EN AW-5754),
painted black

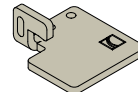

Article 683R
R-clamp
Material: AlMg3 H22
(EN AW-5754),
painted black

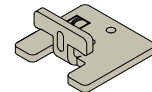

Article 684R
R-clamp
Material: AlMg3 H22
(EN AW-5754),
painted black



Article 657
A2 stainless steel screw,
black head,
RAL 7021, for fastening
of R-clamp

* legally protected

OmegaV profiles and joint profiles OmegaV available for all standard grids over 20 cm (see page 76). Other grids available on request.

Important: The use of silicone caoutchoucs must be absolutely avoided, because silicone fluids segregate and effect sticky surfaces on which dirt adheres. Therefore, only use the system components mentioned (foamed pieces, EDPM rubber profile, neoprene rubber washer) and pointing, bonding and sealing materials recommended by us. We will be pleased to inform you in detail. The usual final cleaning after completion of the construction works is still required. A warranty for the system KeraTwin® K20 in the scope of the general approval no. Z-33.1-1175 of the construction supervisory authority only applies if the system components shown on these pages are used.



Naabtal-Realschule (secondary school), Nabburg, Germany / Architect: Architekturbüro Schönberger / Year: 2016 / Photo: Atelier Bürger



KUBEZ (cultural and meeting centre), Dietach, Austria / Architect: Team M Architekten ZT GesmbH / Year: 2018 / Photo: Roland Reuter, Absam



Thurston Road, London, Great Britain / Architect: ECE Architecture / Year: 2015 / Photo: Alice Jenner



Brofestebygget, Alesund, Norway / Architect: Slyngstad Aamlid Arkitekter / Year: 2015



Residential building Via Mocengio, Milan, Italy / Architect: Beretta Associati / Year: 2019 / Photo: Lorenzo Rimondi

KeraTwin® K20 – Fastening OmegaS with Omega profile and supporting profile



System description

Omega profile and OmegaS supporting profile permit vertical installation of the KeraTwin® facade panels. Secured to the vertical supporting structure, the OmegaS profiles arranged horizontally carry off wind loads and the dead weight of the panels is carried off by the supporting profile mounted in the height grid. The KeraTwin® K20 facade panels are simply hung horizontally in the Omega profiles using the holding grooves on the reverse side. No additional tools are required for mounting the panels. The compression spring integrated in the Omega profile prevents clattering and constraining forces in the case of alternating wind loads. Each KeraTwin® panel is secured using two securing angles to prevent it from slipping out. The horizontal joints can be open or closed with joint profiles.

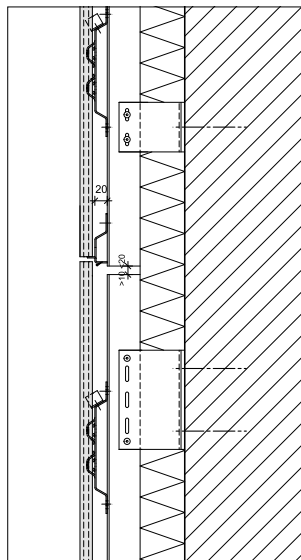

- 1 KeraTwin® K20 facade panel
- 2 Omega profile K20, Article 627
- 3 Supporting profile OmegaS, Article 710
- 4 Securing bracket, Article 711
- 5 Vertical bearing profile (basic substructure)
- 6 Wall bracket (basic substructure)

■ A profile butt joint of the Omega profiles behind a panel is not allowed! See standard technical detail drawings.

Mounting instructions for KeraTwin® K20 – OmegaS with Omega and supporting profile



Mounting instructions as video film:
www.agrob-buchta.de

Substructure

The mounting of the substructure must be carried out according to project-specific, static calculation. The usability certification Z-10.3-844 serves as basis.

- The profiles of the basic substructure have to be mounted perpendicularly and in a flush way.
- Fix the horizontal K20 Omega profiles (Art. no. 627) at the pre-installed vertical substructure by means of the supplied fastening materials. The vertical distance depends on the panel length – single-span girder (= 1/2 of panel length), with jibs on both sides (= 1/4 of panel length).
- Mount the supporting profiles according to the height grid (panel length + 8 mm).
- Fully insert the KeraTwin® panels in the construction
- Position the securing brackets (Art. no. 711) at both Omega profiles and fix them. Alternatively, secure upper and lower end of the panels at the supporting profiles by means of R-clamps (Art. nos. 682R, 683R, 684R).

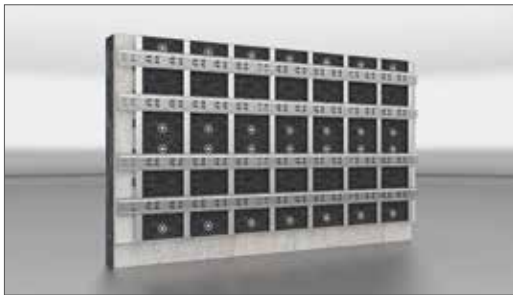

Basic substructure with K20 Omega profiles

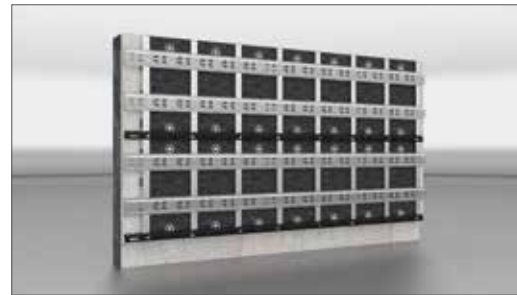

OmegaS with Omega and supporting profiles

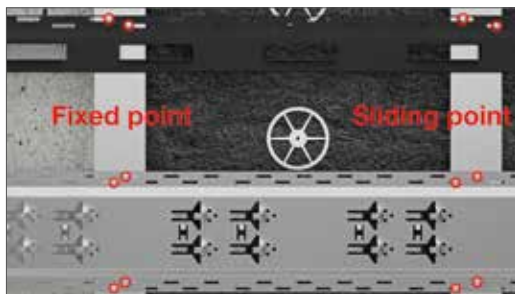

Fixed and sliding point execution



Panel mounting



Securing of the position of the panels at the K20 Omega profiles (with securing brackets)

Accessories: KeraTwin K20® – Fastening with OmegaS supporting profile for vertical mounting

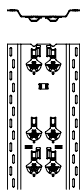

Article 627
Omega profile, bright*
Material: AlMg3 H22
(EN AW-5754),
unpainted

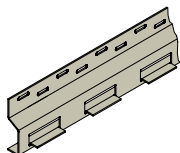

Article 710
OmegaS supporting profile
painted
Material: AlMg3 H22
(EN AW-5754)
painted black
RAL 7021

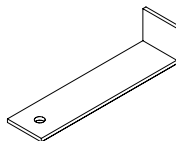

Article 711
Position securing bracket, bright
Material: AlMg3 H22
(EN AW-5754)
unpainted
Box contents: 50 pieces



Article 658
Al blind rivet, bright
Weight: 1.3 kg / box
Nominal dimensions: 4.8 x 10 mm
Box contents: 500 pieces
for the fastening of Omega profile
and OmegaS



Article 659-01
A4 stainless steel screw, bright
Weight: 1.4 kg/box
Nominal dimensions: 4.8 x 16 mm
Box contents: 500 pieces + 1 bit
for the fastening of Omega profile,
OmegaS and position securing
bracket

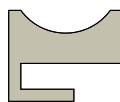

Article 688
Joint profile
Material: EN AW 6063 T66
painted black, RAL 7021,
RAL-color-painted
on request
Length: 1496 mm

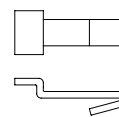

Article 689
Holding clip for joint profile
Material: AlMg1
(EN AW 5005 A)
unpainted
Box contents: 100 pieces

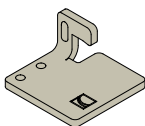

Article 682R
R-clamp
Material: AlMg3 H22
(EN AW-5754),
painted black

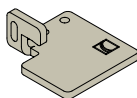

Article 683R
R-clamp
Material: AlMg3 H22
(EN AW-5754),
painted black

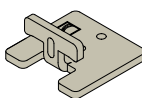

Article 684R
R-clamp
Material: AlMg3 H22
(EN AW-5754),
painted black



Article 657
A2 stainless steel screw,
black head,
RAL 7021, for fastening
of R-clamp

* legally protected

Omega profiles and OmegaS supporting profile available for all standard grids (see page 59). Other grids available on request.

Important: The use of silicone caoutchoucs must be absolutely avoided, because silicone fluids segregate and effect sticky surfaces on which dirt adheres. Therefore, only use the system components mentioned (foamed pieces, EDPM rubber profile, neoprene rubber washer) and pointing, bonding and sealing materials recommended by us. We will be pleased to inform you in detail. The usual final cleaning after completion of the construction works is still required. A warranty for the system KeraTwin® K20 in the scope of the general approval no. Z-33.1-1175 of the construction supervisory authority only applies if the system components shown on these pages are used.



Höxter Markt, Höxter, Germany / Architect: msp architekten GmbH
Year: 2015 / Photo: Mark Wohlrab



Administrative building, Groningen, the Netherlands / Architect: SKETS architectuurstudio / Year: 2015 / Photo: Marcel van der Burg



GIZ-Campus, Bonn, Germany / Architect: CLP GmbH, Koblenz / Year: 2019 / Photo: Jochen Stüber



Green Nest (Foleja e Gjelber) / Architect: PRG*B R architektur, Düsseldorf
Tirana (Germany / Albania) / Year: 2019 / Photo: Lorenzo Rimondi



Kelaty House, London, Great Britain / Architect: Falconer Chester Hall Architects
Year: 2021 / Photo: EH Smith / Simon Hadley Photography

KeraTwin® K20 – Fastening with clamp system K20

Horizontal installation



Vertical installation

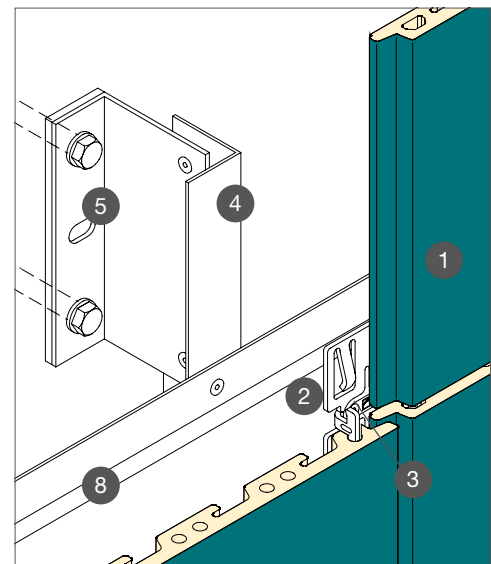

System description

The KeraTwin® K20 facade panels with a maximum panel format of 135 x 50 cm are fixed by means of the clamps K20, which laterally engage with the channels of the facade panel. The compression spring integrated in the clamps prevents clattering and constraining forces in the case of alternating wind loads.

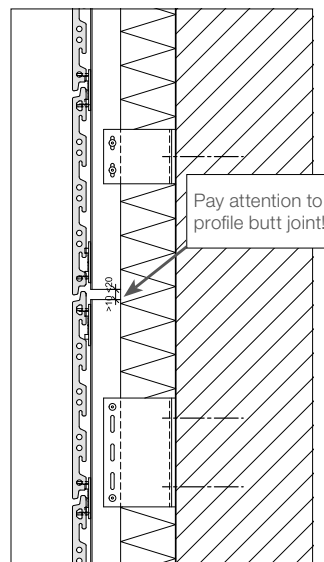

- 1 Facade panel KeraTwin® K20, max. panel format: 135 x 50 cm
- 2 Twin-clamp K20, article 680
- 3 Stainless steel blind rivet, article 675-01, alternatively stainless steel drilling screw, article 657
- 4 Vertical bearing profile (basic substructure)
- 5 Wall bracket (basic substructure)
- 6 Joint tape, black, article 506
- 7 Edge-clamp K20, article 681
- 8 Horizontal bearing profile (basic substructure)

! A profile butt joint of the vertical bearing profiles behind a panel is not allowed! See standard technical detail drawings.

Mounting instructions for KeraTwin® K20 – Fastening with clamp system K20



Mounting instructions as video film:
www.agrob-buchta.de

Substructure

The mounting of the substructure must be carried out according to project-specific, static calculation. The usability certification Z-10.3-844 serves as basis.

- The profiles of the basic substructure have to be mounted perpendicularly and in a flush way.
- The distance of the bearing profiles (profile width ≥ 60 mm) in horizontal direction must correspond to the longitudinal grid of the panels.
- The length of the vertical profiles must be divisible by the height of the panel format and should not exceed the height of a storey of the building.
- A profile butt joint behind a panel is not allowed.
- In the vertical joints, the black joint tape (Art. no. 506) can be applied.
- The clamps (Art. no. 680, 681, 682, 683, 684) must be fastened with at least 2 rivets (Art. no. 675-01) or 2 screws (Art. no. 657).
- For the processing of the rivets (Art. no. 675-01), an extended rivetting tool (25 mm) is required.
- For the processing of the screws, an extended bit is required.
- In the area of the clamp fastening, the joints can be closed with the joint profile (Art. no. 688) and one holding clip for joint profile (Art. no. 689) per panel.



Basic substructure



Apply joint tape on vertical bearing profiles



Fasten edge-clamps with stainless steel blind rivet
(Art. no. 675-01)



Mount the KeraTwin® panels in vertical rows

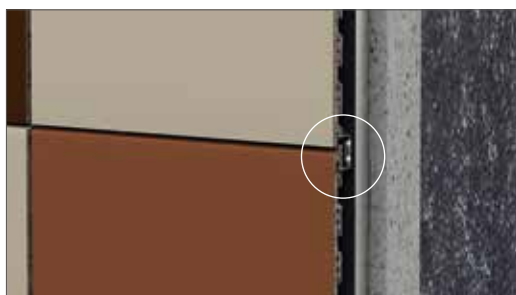

Termination with edge-clamps

Accessories: KeraTwin® K20 – Fastening by means of clamp system K20

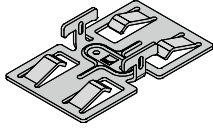

Article 680
Twin-clamp K20*
Weight: 45 kg / 1,000 pieces
Perforation: 2 x 3.3 mm Ø
Material: AlMg3 H22
(EN AW-5754),
painted black,
RAL 7021

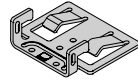

Article 681
Edge-clamp K20*
Weight: 24 kg / 1,000 pieces
Perforation: 4 x 3.3 mm Ø
Material: AlMg3 H22
(EN AW-5754),
painted black,
RAL 7021

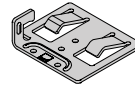

Article 682
Edge-clamp K20, left
Weight: 24 kg / 1,000 pieces
Perforation: 4 x 3.3 mm Ø
Material: AlMg3 H22
(EN AW-5754),
painted black,
RAL 7021

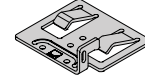

Article 683
Edge-clamp K20, right
Weight: 24 kg / 1,000 pieces
Perforation: 4 x 3.3 mm Ø
Material: AlMg3 H22
(EN AW-5754),
painted black,
RAL 7021

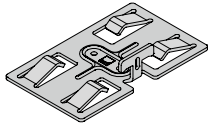

Article 684
Single-clamp K20
Weight: 45 kg / 1,000 pieces
Perforation: 2 x 3.3 mm Ø
Material: AlMg3 H22
(EN AW-5754),
painted black,
RAL 7021



Article 657
A2 stainless steel screw,
black head,
RAL 7021
Box contents: 500 pieces

Clamp delivery:
– Twin- and single-clamps: 7 pieces/string
– Edge-clamps: 13 pieces/string



Article 675-01
Stainless steel blind rivet, black
Weight: 1.05 kg / box
Nominal dimensions: 3.2 x 9.5 mm
Box contents: 500 pieces
extended mandrel (58 mm)

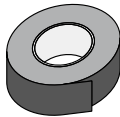

Article 506
Joint tape, black
Weight: 0.5 kg / roll
Nominal dimensions:
40 mm wide, 50 m
self-adhesive, weather-resistant

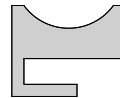

Article 688
Joint profile
Material: EN AW 6063 T66
painted black,
RAL 7021,
RAL-color-painted
on request
Length: 1496 mm

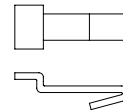

Article 689
Holding clip for joint profile
Material: AlMg1
(EN AW 5005 A)
unpainted
Box contents: 100 pieces

* legally protected

Important: The use of silicone caoutchoucs must be absolutely avoided, because silicone fluids segregate and effect sticky surfaces on which dirt adheres. Therefore, only use the system components mentioned (foamed pieces, EDPM rubber profile, neoprene rubber washer) and pointing, bonding and sealing materials recommended by us. We will be pleased to inform you in detail. The usual final cleaning after completion of the construction works is still required. A warranty for the system KeraTwin® K20 in the scope of the general approval no. Z-33.1-1175 of the construction supervisory authority only applies if the system components shown on these pages are used.

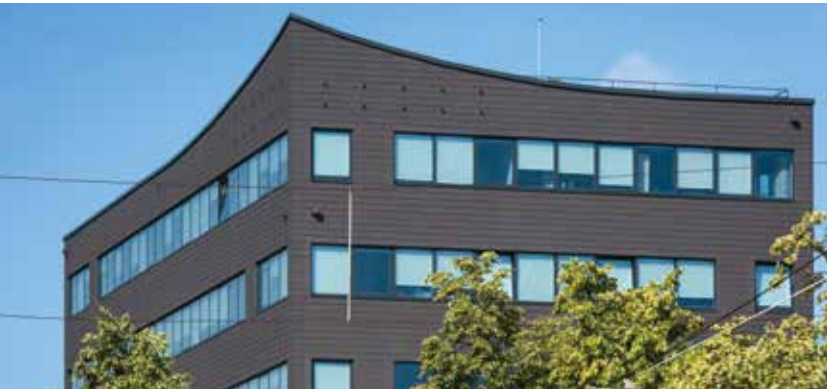

Mikrovisata, Kaunas, Lithuania / Architect: G. Natkevicius ir partneriai, UAB / Year: 2015 / Photo: Leonas Garbačauskas



Piliamiestis, Kaunas, Lithuania / Architect: UAB Kita kryptis / Year: 2016 / Photo: Leonas Garbačauskas



Résidence L'Emblem (Quartier Cleunay), Rennes, France / Architect: Claire Gallais Architectures // associated architect: PNCL Architecture / Year: 2021 / Photo: Marc Loyon



Bowhuis Zoetermeer, the Netherlands / Architect: Klunder Architecten / Year: 2006 / Photo: Rob Hoekstra



Ufa, Russia / Architect: Bashkirgrazhdanprojekt, Pavel Mazin / Year: 2015 / Products: KeraTwin®

KeraTwin®

Detail solutions for KeraTwin®

For ensuring the visual and technical perfection of corners and borders as well, AGROB BUCHTAL has developed standard technical details, which can be adapted to the project-specific requirements as needed – also as special production.

This includes, for example, terminations at windows, doors and the corresponding embrasures, both horizontal and vertical. In addition, mitre-cut panels for corner profiles facilitate the convincing design of sophisticated facade details.



Beijing Airport Industrial Park / Peking, China / Architect: Perkins + Will

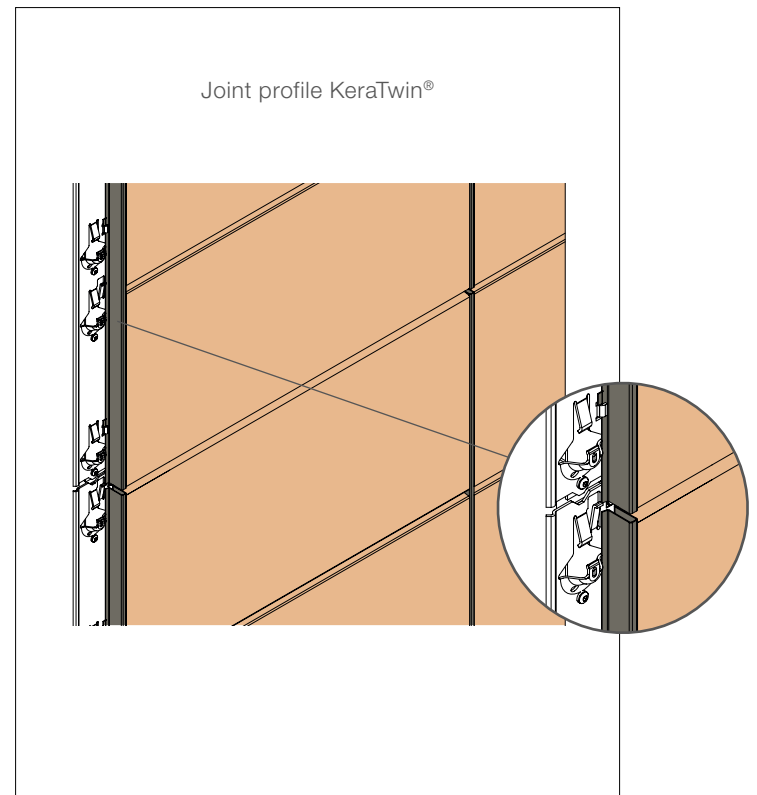
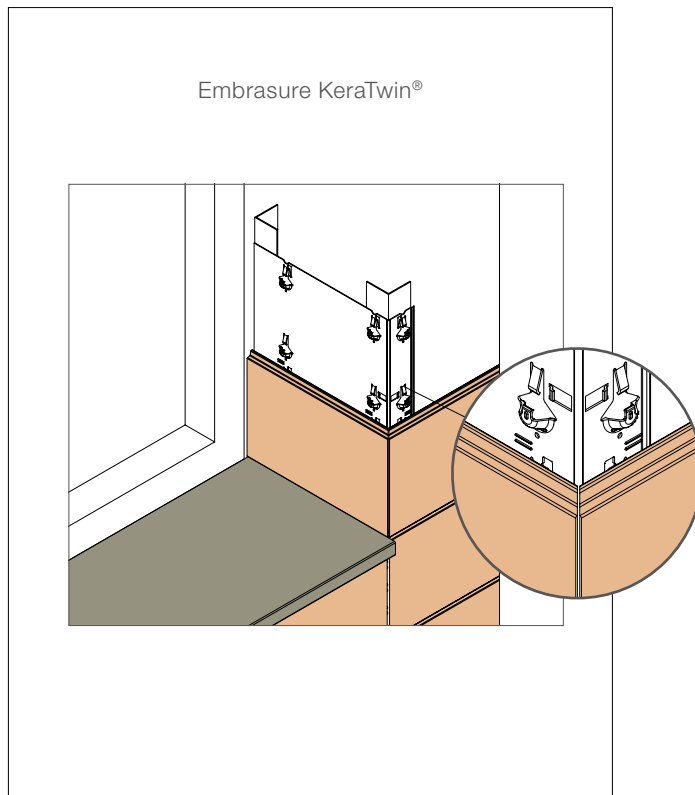

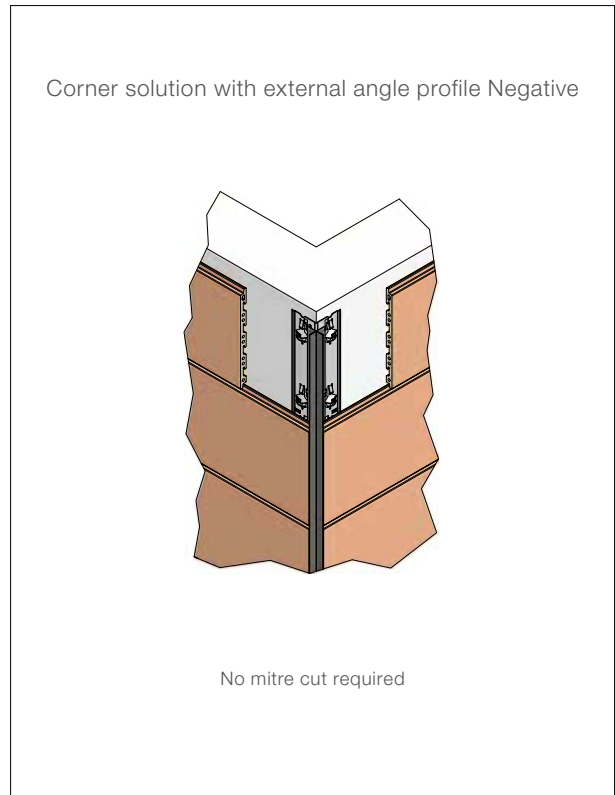
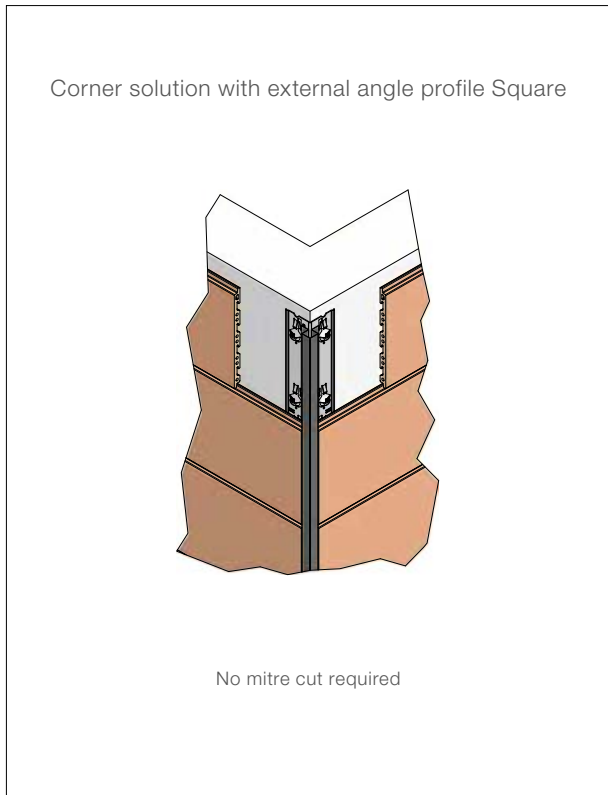
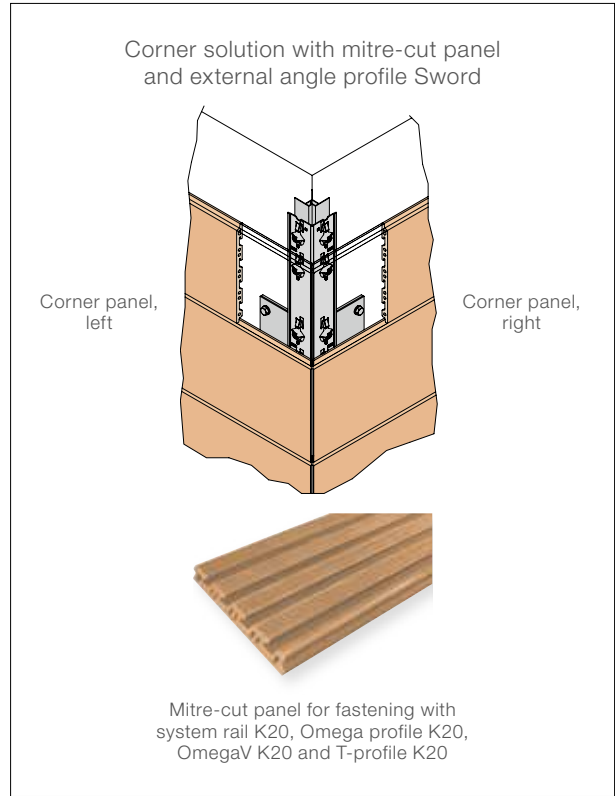
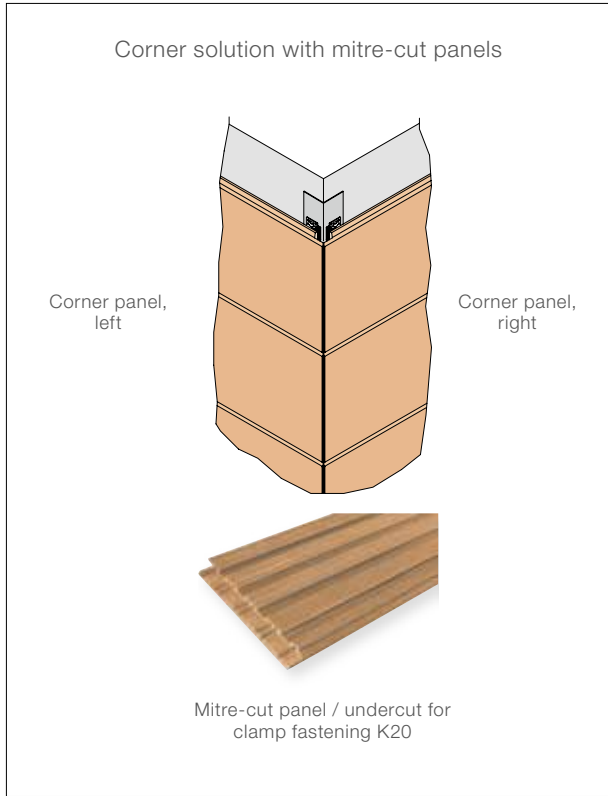

KERASHAPE®

Ceramics in profile

With its extensive bandwidth, “KeraShape®” is primarily aligned towards setting highlights and supporting architects in realizing individual concepts. Apart from their function as elements of architectural design, these special pieces also serve entirely practical purposes as visual and sun protection.

The standard range comprises rectangular tubes with cross-sections of 50 x 60 mm and 60 x 60 mm in lengths of up to 1,800 mm, with lengths of up to 1,500 mm for the 50 x 100 mm variants. These are complemented by rounded lamellar elements in 140 x 60 mm with a maximum length of 1,200 mm. Using special fastening sets, the individual elements can be merged to form compact units and visually extended.

Even these standard items – which are perfectly co-ordinated to the other facade systems offered by AGROB BUCHTAL – permit numerous design variants. Furthermore, individual special shapes and sizes are possible depending on the respective building. After a brief examination of the individual case, experts at AGROB BUCHTAL are delighted to provide a technical and economic feasibility analysis. This also applies to individual fastening concepts deviating from standard fastening variants.

As the special pieces – glazed or unglazed – are supplied in practically any color nuance also available for facade panels, there is nothing to stand in the way of tone-in-tone design. But contrasting colors are also a popular option as they open up numerous possibilities for making large facades appear less monotonous. The same also applies to the special pieces themselves when used to achieve a visual rhythm.



StudierQuartier im WissenschaftsPark Osnabrück,
Germany / Architect: PLAN.CONCEPT Architekten
GmbH, Osnabrück / Year: 2020 / Products: KeraShape®
Photo: Jochen Stüber, Hamburg





Ammattiopisto Live, Espoo, Finland
Architect: Linja Arkkitehdit Oy, Helsinki, Finland
Year: 2019 / Product: KeraShape®
Photos: Sonja Meskanen, Lempäälä

Vocational College Live, Espoo

The Vocational College Live in Espoo is the largest special needs education institution in the Helsinki metropolitan area. It is located in the lively Turuntie district. This striking new building is a major feature of Turuntie's cityscape. Ceramic KeraShape® elements give the Vocational College its unique look. Because they support the striking design of the architects.





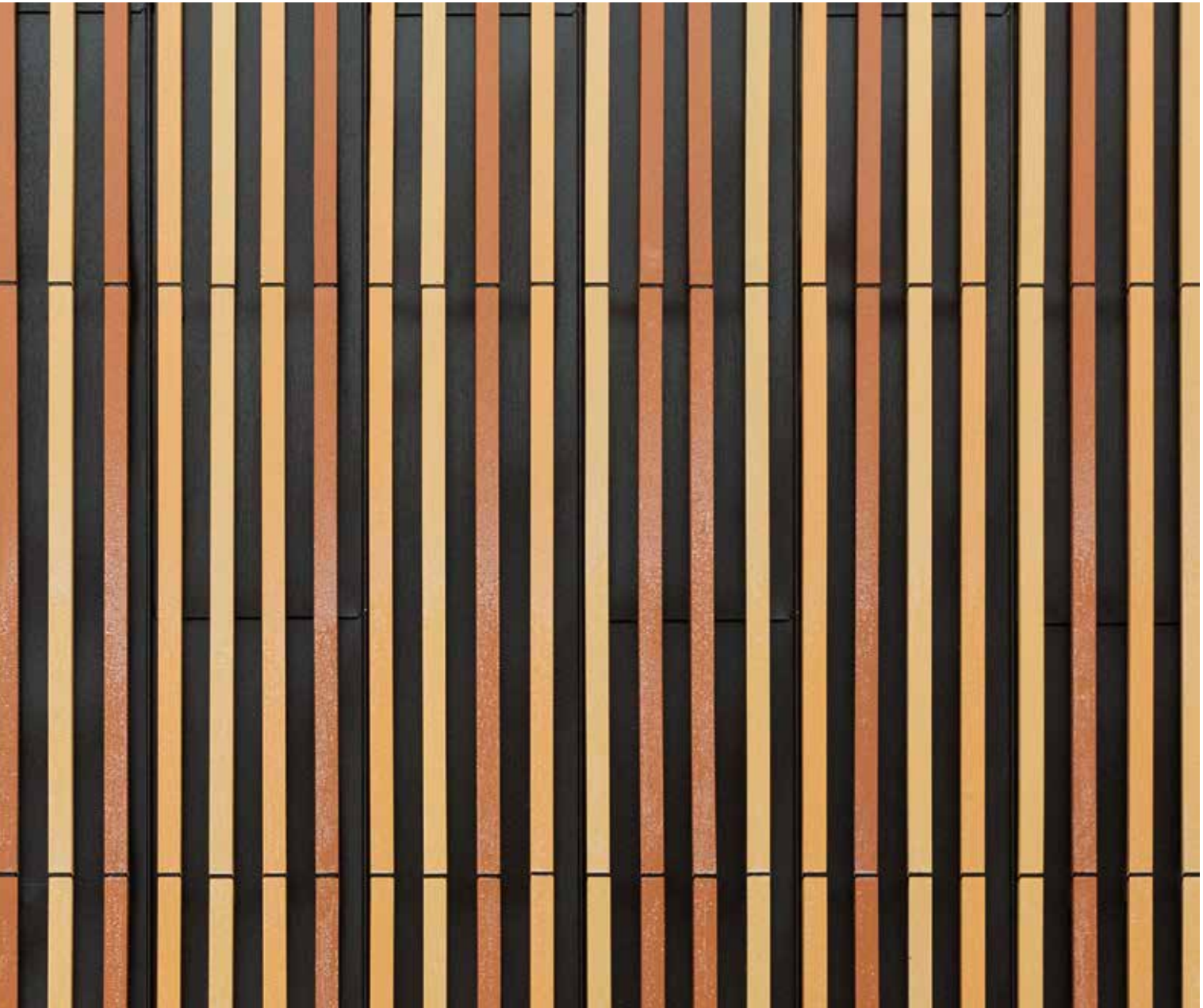

The Vocational College Live in Espoo was planned and realized by LINJA ARCHITECTS - one of the largest architecture firms in Finland. On 11,000 m², space was created there for the work of the special education teachers. Already the shape of the building is striking and impressive. In an aesthetic sense it virtually crosses the rocky slope next to the Turuntie district. The solid mass follows the terrain, thus forming a protected inner courtyard. The shell-like facade on the south and the west side is designed with large ceramic elements. Even the windows visually disappear behind this striking element.

"The color range and the look blend in well with the surrounding green district. The urban planning committee of Espoo also liked the idea of the ceramic facade as a natural material", says the architect Juha Kujanpää, Design Director of LINJA ARCHITECTS. The ceramic facade also performs a number of functional tasks: it filters sunlight which is reflected

from outside to inside. It also mixes it with the artificial light inside. This makes the daily activities easier for the partially visually impaired pupils. The ceramic tubes of the facade also provide protection against too much sunlight and have a cooling effect.

A total of 20,000 metres of KeraShape® special pieces were used on the outer facade of this project. In different colors (red, ochre and salmon-red), they give the building an almost tangible plasticity and massive visual presence for the viewer. Paired with the natural wood on the facade of the inner courtyard side, an organic overall picture is created. Another special feature: while the wood will slowly turn into grey over the years – as the architects have planned – the colors of the facade ceramics will definitely remain unchanged.



Chateau Troja Residence, Prague, Czech Republic / Architect: Atelier Loxia a.s., Prague
Year: 2020 / Products: KeraShape®, KeraTwin® / Photos: Vojtech Kubec





Color and form as architectural stylistic devices

This new student hall of residence of the Osnabrück Student Union is located on the edge of a green area not far from the university. The building immediately catches the eye, simply because – unlike most campus buildings – it is not grey. Instead, it appears pleasantly colorful.





KeraShape®

While the four-storey student hall of residence seems to want to retreat into the background and blend in with the trees of the green area from a distance, it reveals itself as a resolutely self-confident new building when drawing nearer. At first it becomes clear that the building appears so dynamic not only because of its colorfulness, but also because it has an undulating curtain-type facade. This dynamism is based on a sine wave, which plays an important part in nature, but also in many scientific subjects of study. If you get even closer, the colorful overall impression is differentiated into individual fine color stripes. They symbolically express the lively student life.



The single-colored stripes consist of a total of 9,574 ceramic rectangular special pieces from the "KeraShape®" series of AGROB BUCHTAL, which are arranged in several layers on top of each other – usually 114, 145 or 81 cm long and with a cross-section of 50 x 60 mm. They are glazed in six different colors, each on four sides, and do not differ from each other except in their color and length. Due to this uniformity and because they are mounted to the substructure with invisible clamps, the impression of jointless continuous color stripes or bars is created.

The planners of PLAN.CONCEPT Architekten had designed the color appearance of the building with great care. They decided on a total of six reddish and green RAL colors, which AGROB BUCHTAL then translated into ceramics. Ceramics as a facade material was decided relatively quickly by the architects. Wood, for example, would have been too high-maintenance, and aluminium would have been too environmentally damaging due to its high energy input during production. However, the sustainability aspect also played a major part for them. On the one hand, they wanted to create a house in which the up to 124 students will also feel comfortable in the future. On the other hand, the material of the building envelope had to fit the plus-energy house concept with photovoltaics, solar thermal system and heat pump, and consequently be made of a durable, natural raw material.





KeraShape®



StudierQuartier im WissenschaftsPark Osnabrück, Germany / Architect: PLAN.CONCEPT Architekten GmbH, Osnabrück / Year: 2020
Products: KeraShape® / Photo: Jochen Stüber, Hamburg



Schloss-Schule Kirchberg (school), Kirchberg an der Jagst, Germany / Architects: Architekturbüro Mix, Rolf Däuber, Schwäbisch Hall / Year: 2021
Products: KeraShape® / Photos: Andreas Bohle



KeraShape®





Forms, colors and formats for KeraShape®

Whether as protection against view and sun or for giving large facade surfaces a rhythm – KeraShape® elements are extremely versatile and set visual accents. They are available as rectangular tubes with three or four glazed sides in three different cross-sections and lengths of up to 180 cm as well as in rounded lamellar form. The great variety of colors comprises the SpectraView range with its harmoniously matched color families with silky-matt glaze and glossy glazed contrasting colors as well as the unglazed Natura shades. On request, a special production according to individual specifications is also possible.

KeraShape® forms and formats

KeraShape® "Extruded Ceramic Panels, Precision, with an average water absorption of $3\% < E \leq 6\%$, group All_a, part 1, annex B, glazed (GL) and unglazed (UGL)"

KeraShape® "Extruded Ceramic Panels, Precision, with an average water absorption of $6\% < E \leq 10\%$, group All_b, part 1, annex D, glazed (GL) and unglazed (UGL)"



Rectangular tube
 50 x 60 mm / 60 x 60 mm
 Work size: 50 x 60 mm / 60 x 60 mm
 Weight: 50 x 60 mm: 4.29 kg / lin. m.
 60 x 60 mm: 4.49 kg / lin. m.
 available unglazed as well as with
 4 glazed sides.
 Possible up to a length of 1,800 mm on request

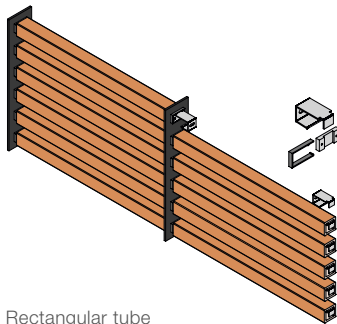

Rectangular tube

Cross-section of rectangular tube



Rectangular tube
 50 x 100 mm*
 Work size: 50 x 100 mm
 Weight: 6.84 kg / lin. m.
 available unglazed as well as with
 4 glazed sides.
 Possible up to a length of 1,500 mm on request

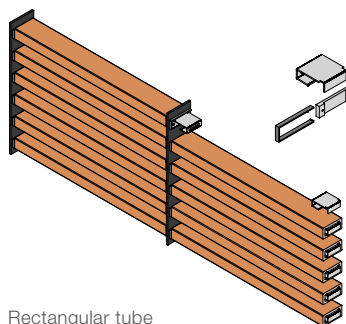

Rectangular tube

Cross-section of rectangular tube



Lamellar element
 Work size: 140 x 60 mm
 Weight: 9.00 kg / lin. m.
 possible up to a length
 of 1,200 mm,
 available only unglazed

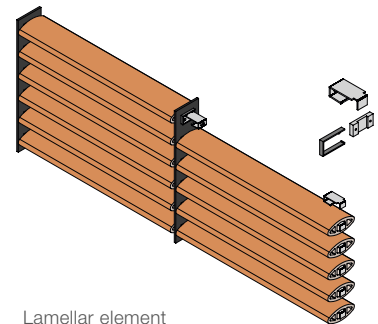

Lamellar element

Cross-section of lamellar element

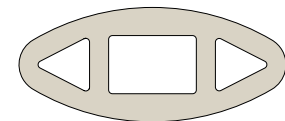

In addition to the variants shown, the production of individual articles is also possible. After a short check of the individual case for technical and economical feasibility, we will be pleased to provide you with project-specific information.

KeraShape® with horizontal laying

System description

Three-dimensional ceramic special pieces in natural colors or also in glazed version are used for making large facade surfaces less monotonous or for producing shade at buildings. For

developing individual, project-related fastening proposals, please contact us. Information about the standard fastening systems is to be found in the respective technical details. Various individual

solutions are available for the horizontal laying. We will be pleased to advise you on request and determine the best, project-related fastening together with you.

KeraShape® with vertical laying

System description

Rectangular tubes in various dimensions and colors in unglazed or glazed version can also be vertically installed. For developing individual, project-related

fastening proposals, please contact us. Special fastening clamps are available for all standard variants of the ceramic rectangular tubes (joint width: 10 mm).

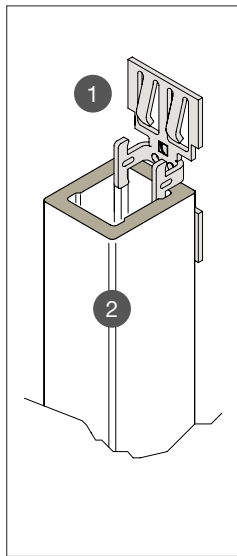

1 Fastening clamp

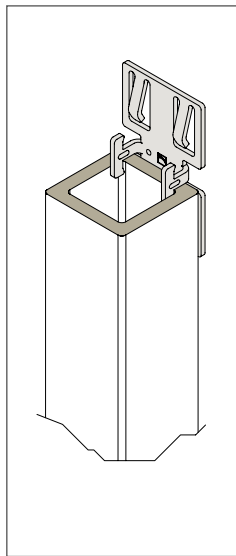

2 Rectangular tube

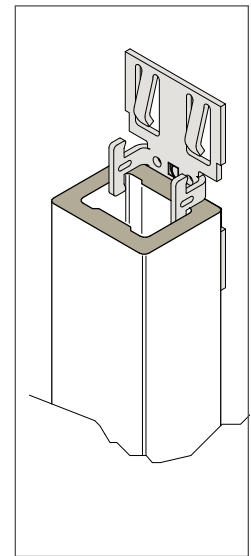
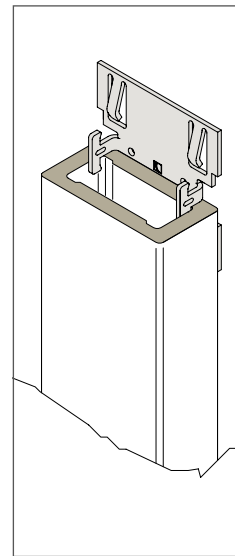
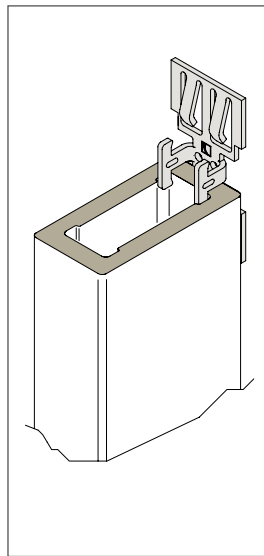

Accessories: KeraShape® with vertical laying

Fastening clamps:

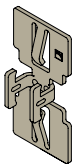

Article 685-50100-01
Twin-clamp
for 50 mm width in case of rectangular tube 50 x 100
Perforation: 2 x 4.9 mm
Material:
AlMg3 H22 (EN AW-5754)
painted black
Weight: 35 kg / 1,000 pcs.

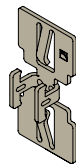

Article 685-5060-01
Twin-clamp
for 50 mm width in case of rectangular tube 50 x 60
Perforation: 2 x 4.9 mm
Material:
AlMg3 H22 (EN AW-5754)
painted black
Weight: 35 kg / 1,000 pcs.



Article 686-6060-01
Twin-clamp
for 60 mm width in case of rectangular tube 60 x 60 and 60 x 50
Perforation: 2 x 4.9 mm
Material:
AlMg3 H22 (EN AW-5754)
painted black
Weight: 45 kg / 1,000 pcs.

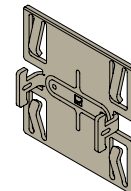

Article 687-10050-01
Twin-clamp
for 100 mm width in case of rectangular tube 50 x 100
Perforation: 2 x 4.9 mm
Material:
AlMg3 H22 (EN AW-5754)
painted black
Weight: 90 kg / 1,000 pcs.



Article 657
A2 stainless steel screw,
black head,
RAL 7021, for fastening
of R-clamp

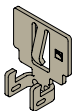

Article 685R-50100-01
Terminal-clamp
for 50 mm width in case of rectangular tube 50 x 100
Perforation: 2 x 4.9 mm
Material:
AlMg3 H22 (EN AW-5754)
painted black
Weight: 20 kg / 1,000 pcs.

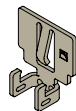

Article 685R-5060-01
Terminal-clamp
for 50 mm width in case of rectangular tube 50 x 60
Perforation: 2 x 4.9 mm
Material:
AlMg3 H22 (EN AW-5754)
painted black
Weight: 20 kg / 1,000 pcs.

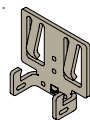

Article 686R-6060-01
Terminal-clamp
for 60 mm width in case of rectangular tube 60 x 60 and 60 x 50
Perforation: 2 x 4.9 mm
Material:
AlMg3 H22 (EN AW-5754)
painted black
Weight: 24 kg / 1,000 pcs.

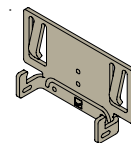

Article 687R-10050-01
Terminal-clamp
for 100 mm width in case of rectangular tube 50 x 100
Perforation: 2 x 4.9 mm
Material:
AlMg3 H22 (EN AW-5754)
painted black
Weight: 48 kg / 1,000 pcs.

SpectraView glazed, silky-matt

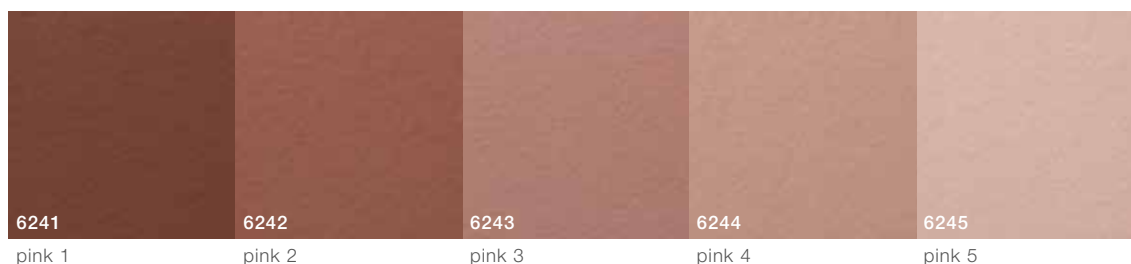
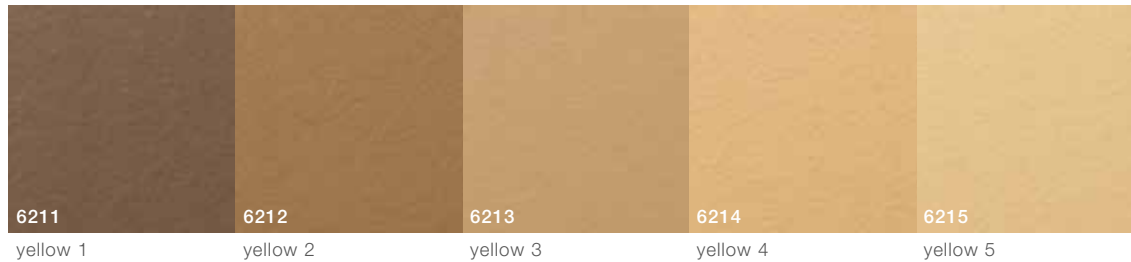
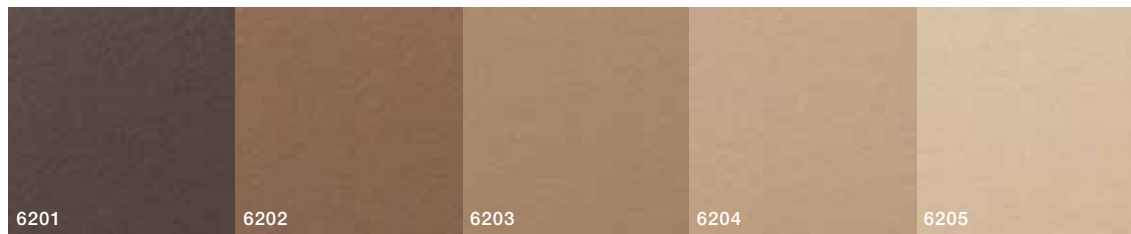

Due to production reasons, color deviations compared to the KeraTwin® panels as well as slight differences in nuances can not be excluded.

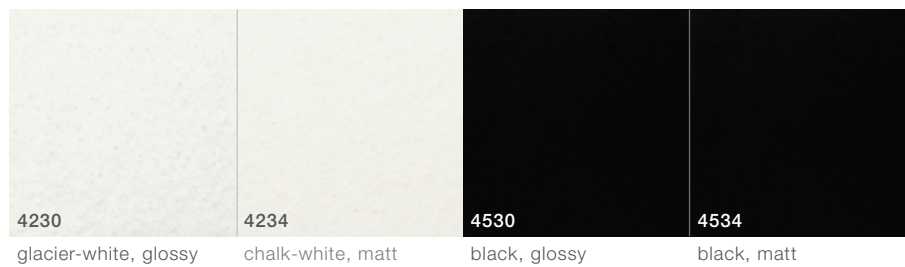
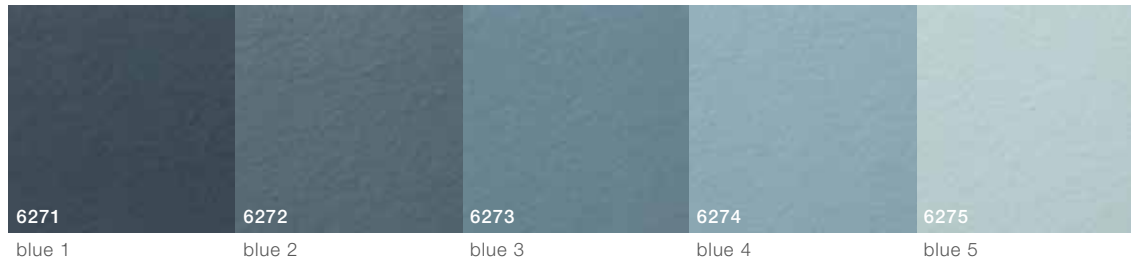

Contrasting colors, glazed, glossy

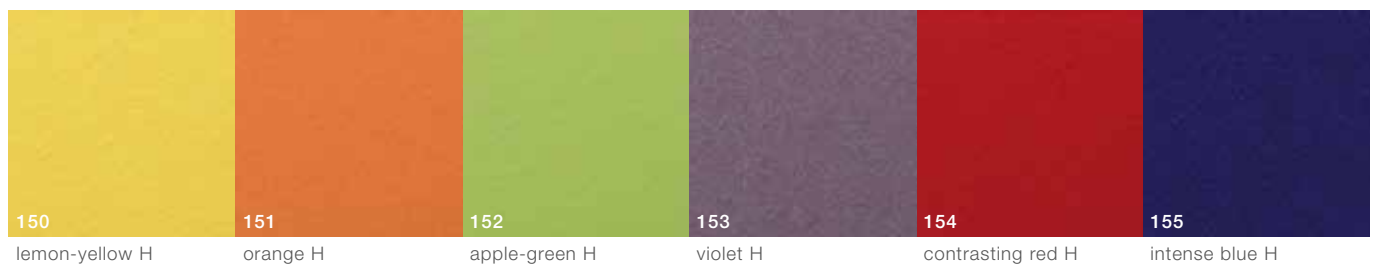

Natura unglazed



Due to production reasons, color deviations compared to the KeraTwin® panels as well as slight differences in nuances can not be excluded.

* Not available as lamellar element special piece.

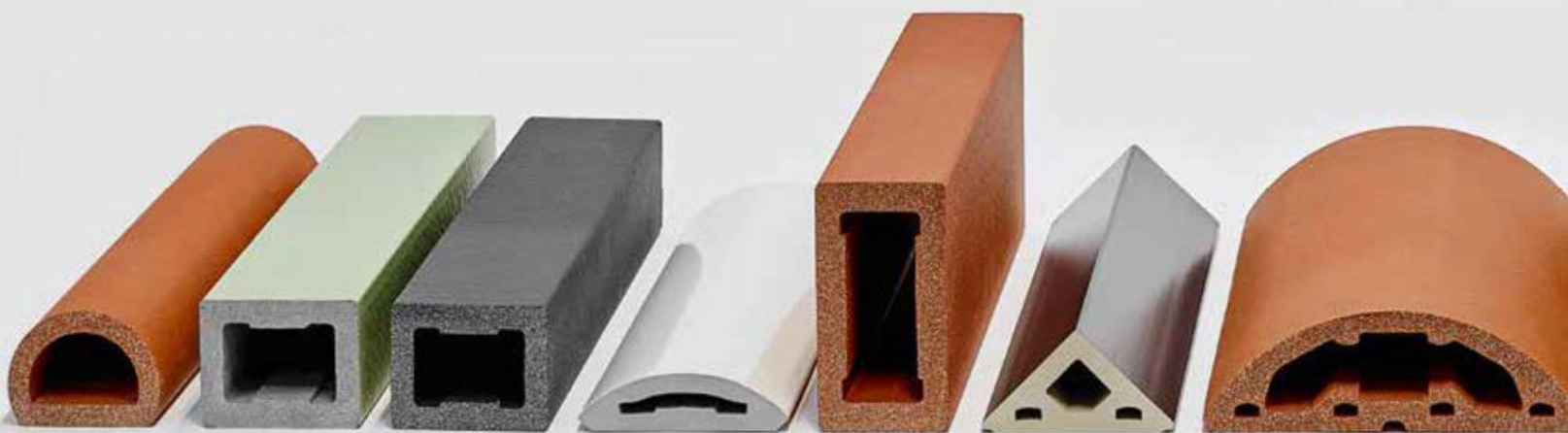

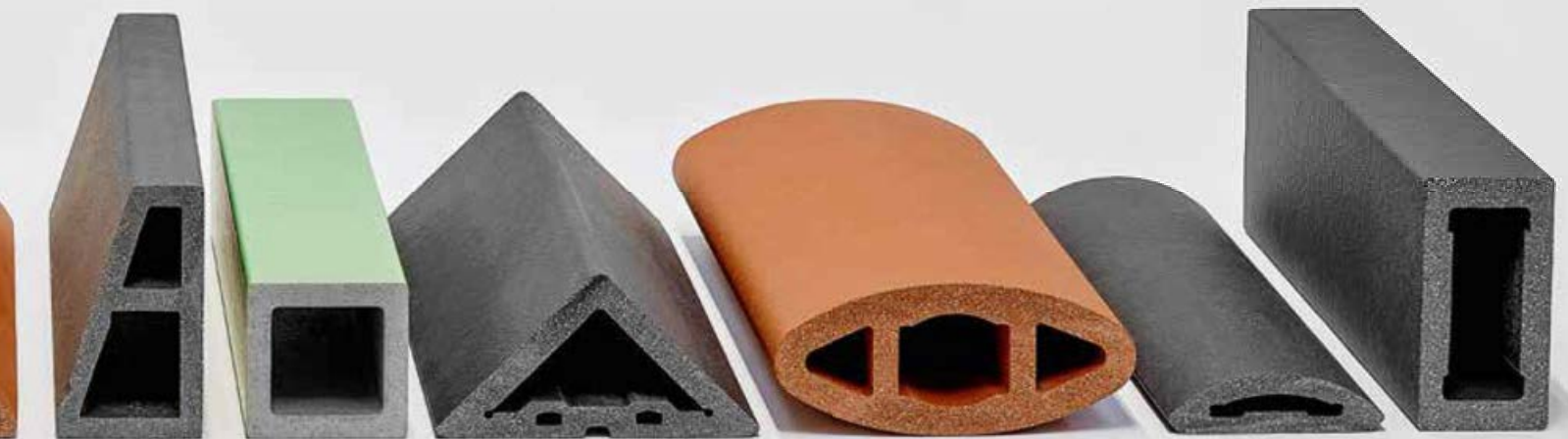
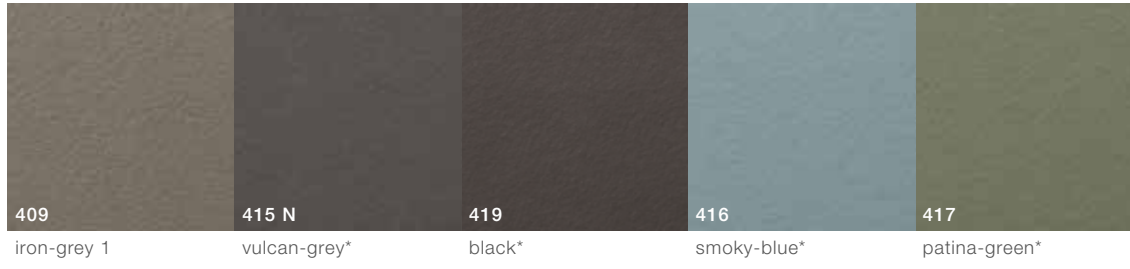

KERAION®

Ceramics in large format

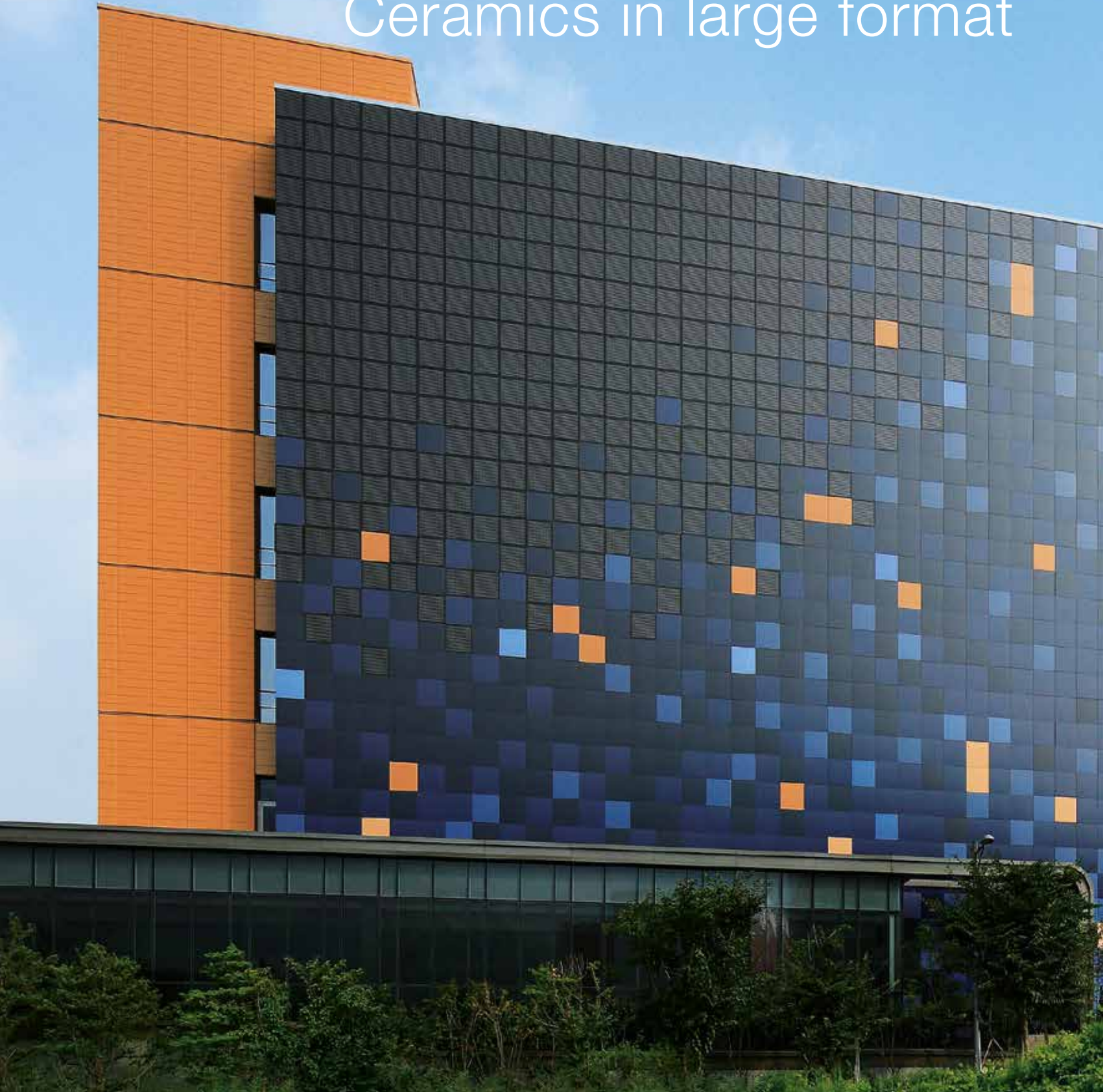

Designing with colors

Used world-wide for decades, the KerAion® facade system also offers – besides low weight – alternatives to the otherwise quite usual board formats. In addition to customary rectangular and square panels, large formats of 60 x 60 cm, 90 x 90 cm and 60 x 120 cm are also available, which are particularly suitable for the facade design of big buildings. They can be fastened on the substructure both traditionally with clamps and invisibly with undercut anchors.

All versions and formats received the general approval of the construction supervisory authority and also prove themselves in case of a statically demanding building structure. A high degree of creative freedom is ensured by the color range. Just as in the case of KeraTwin®, it is based on SpectraView, the range of nine color families matched to each other and several contrasting colors, which was developed by the color designer Peter Zoernack. It is completed by the “Design glazed” colors in different looks such as cement, stone or metal.

The only 8 mm thin KerAion® panels with the very low weight of 18 kg/m² are fastened by means of clamps, and the color of the clamp lips is matched to the design of the ceramic panel. A system with many advantages and well thought-out system components, both on metal and wooden substructure.



Seestadt Aspern – Inside Out

Seestadt Aspern is one of the oldest residential areas of Vienna and one of the largest urban development projects in Europe. In Vienna's 22nd district, housing and work for at least 20,000 people is to be developed until 2028. With the focus on climate-sensitive urban development, the new district places emphasis on the quality of public spaces, the



inclusion of nature, social diversity and design sustainability. In the middle of it all, there is a residential complex whose ceramic facades in the intense blue of AGROB BUCHTAL's KerAion® series add a real bang to the master plan.

Quality through scale

The residential building was planned by the architecture office Albert Wimmer (AWZT) in Vienna. Open and inviting, an ensemble of four individual buildings skilfully combines to form a quarter. This is made possible by the ceramic shell as a design bracket. The blue of the "Design glazed" colors of the KerAion panels in the outer facade skin clearly contrasts with the white plaster of the inner courtyard world, catches the eye and allows passers-by from near and far to explore exciting views and insights of an architecture which Albert Wimmer designed in all details with the scale that constitutes urban development quality and guarantees buildings a long life.

Facade makes climate

With the KerAion® system, Albert Wimmer Architects have also thought ahead to the climate when planning the facade. In addition to the low weight, material and energy consumption of the 8 mm thin, but consistently robust and striking ceramic panel, the long service life and a building material which can not only be completely recycled, but also removed and reused with the AGROB BUCHTAL system for rear-ventilated facades are convincing. Provided with Hytect technology already at the factory, the KerAion panels form an innovative envelope which offers economic and ecological added value thanks to its self-washing effect and the reduction of air pollutants such as nitrogen oxide. This is an asset for the "aspern klimafit" programme, which was set up to consistently minimize the climatic impacts of building construction.



Seestadt Aspern, Vienna, Austria / Architect: Albert Wimmer ZT-GmbH, Vienna, Austria
Year: 2017 / Products: KerAion®, clamp fastening / Photos: Fotodesign Peters, Amerang





Landesbank (state bank) Baden-Württemberg, Reutlingen, Germany / Architect: BW Immobilien GmbH, Stuttgart
Year: 2014 / Products: KerAion®, Quadro bearing profile / project-specific individual production / Photos: Andreas Körner



KerAion®



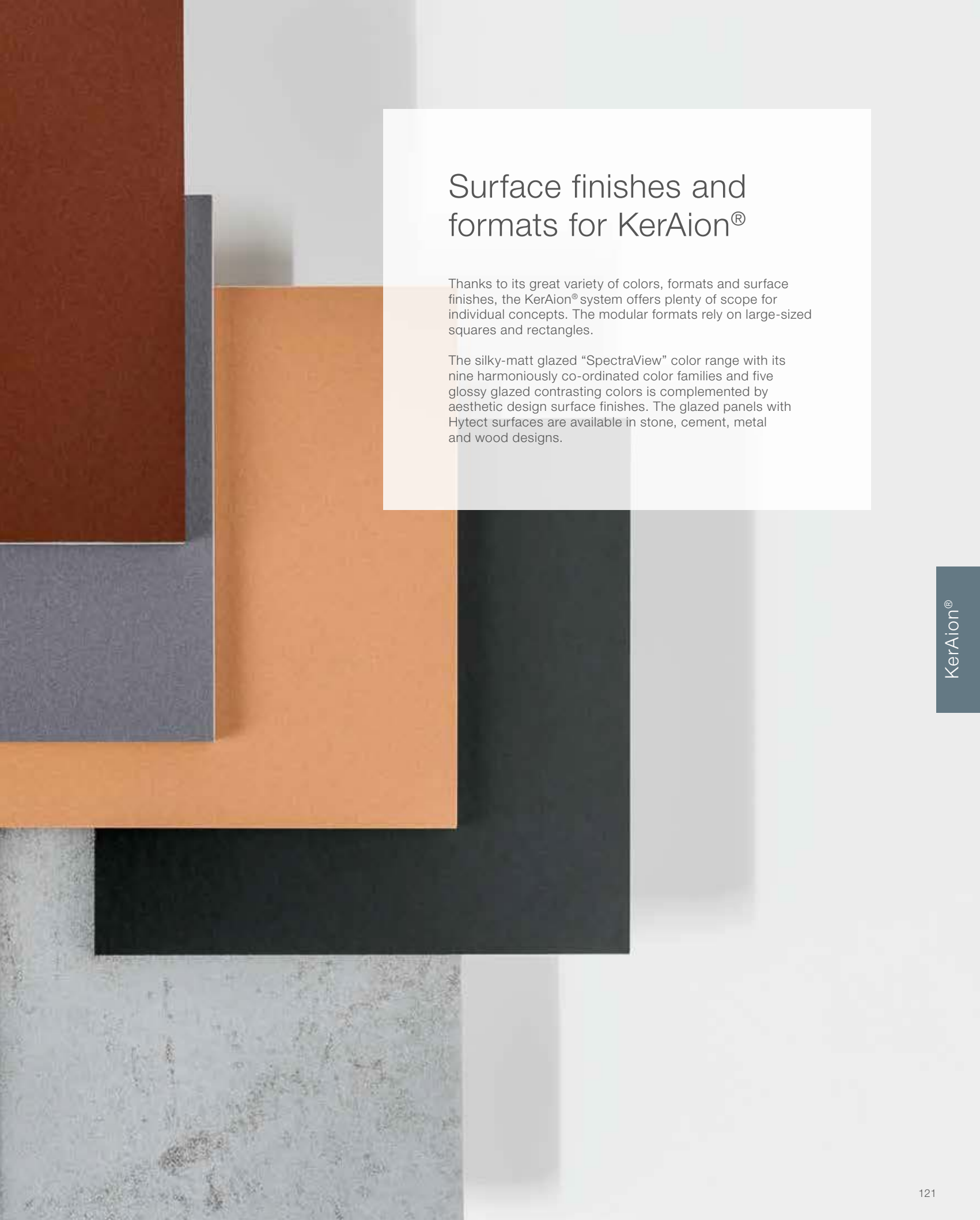

Surface finishes and formats for KerAion®

Thanks to its great variety of colors, formats and surface finishes, the KerAion® system offers plenty of scope for individual concepts. The modular formats rely on large-sized squares and rectangles.

The silky-matt glazed “SpectraView” color range with its nine harmoniously co-ordinated color families and five glossy glazed contrasting colors is complemented by aesthetic design surface finishes. The glazed panels with Hytect surfaces are available in stone, cement, metal and wood designs.

Surfaces for KerAion®



Elegant look

With their smooth, silky-matt surface, KerAion® panels lend every facade an elegant look. Individual design concepts are supported by the wide color range.

Formats for KerAion® K8

Extruded Ceramic Panels, Precision, DIN EN 14411, group Alb, glazed (GL), (large-size stoneware panels), 8 mm thick, 18 kg/m²

Standard sizes: 60 x 60 cm / 592 x 592 mm, 60 x 90 cm / 592 x 892 mm,
(grid size / 90 x 90 cm / 892 x 892 mm, 60 x 120 cm / 592 x 1,192 mm
work size) Other sizes available on request.



Clamp fastening

Article K100HK
60 x 60 cm



Article K104HK
60 x 90 cm



Article K416HK
90 x 90 cm



Article K418HK
60 x 120 cm



SpectraView glazed, silky-matt

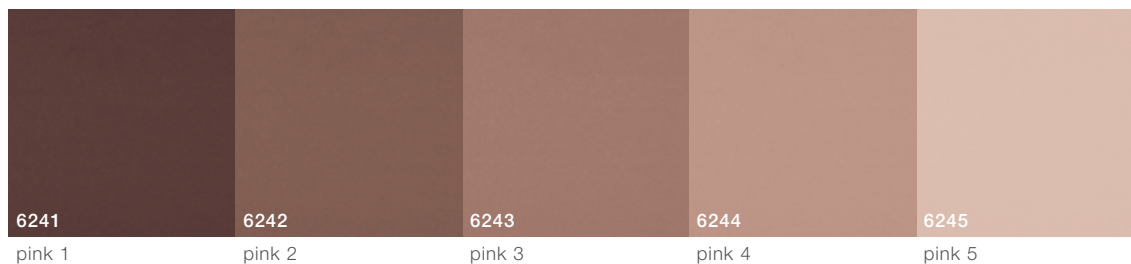
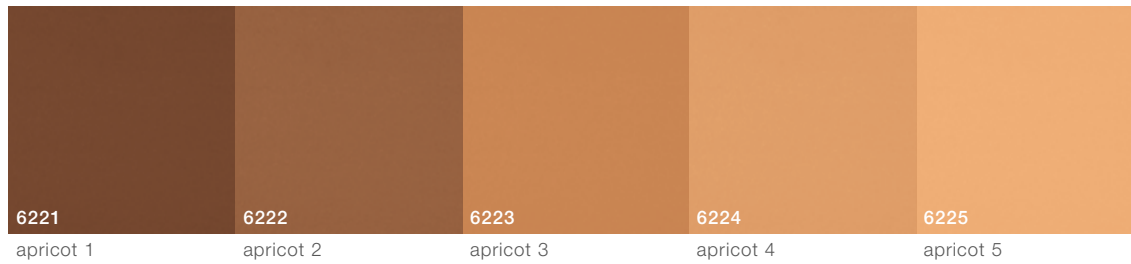
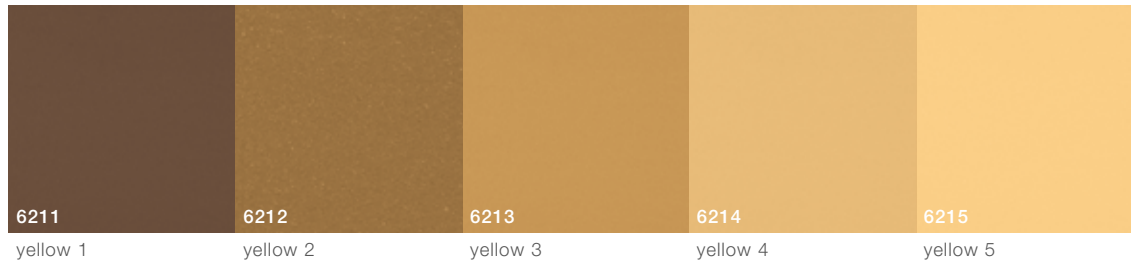

H = Hytect surface

In addition to the variants shown, the production of individual articles is also possible. After a short check of the individual case for technical and economical feasibility, we will be pleased to provide you with project-specific information.

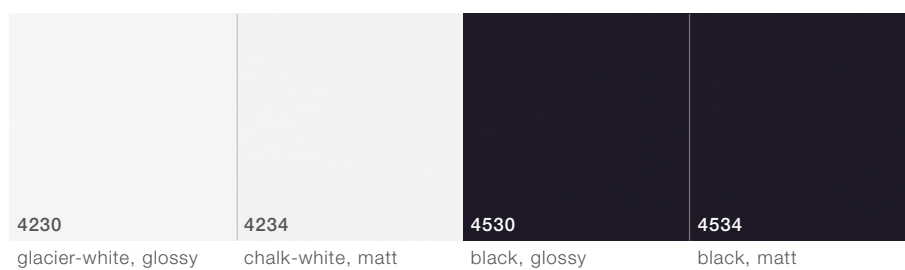
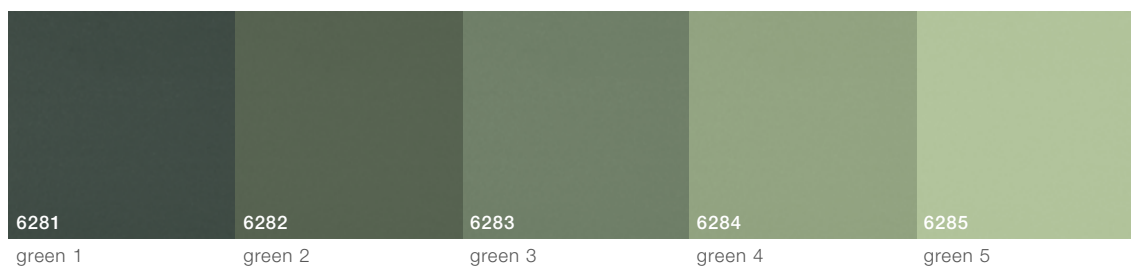
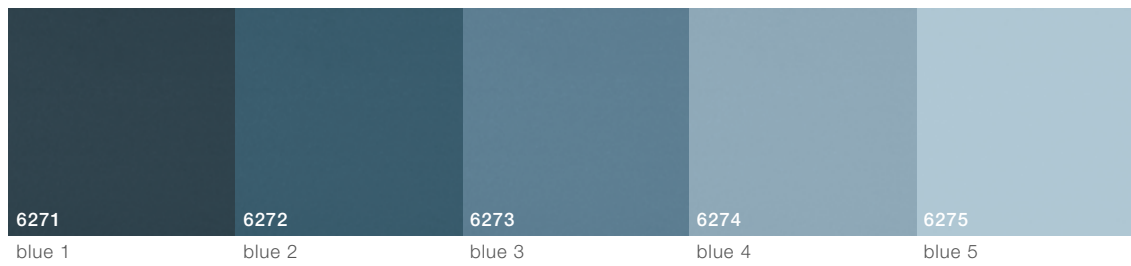
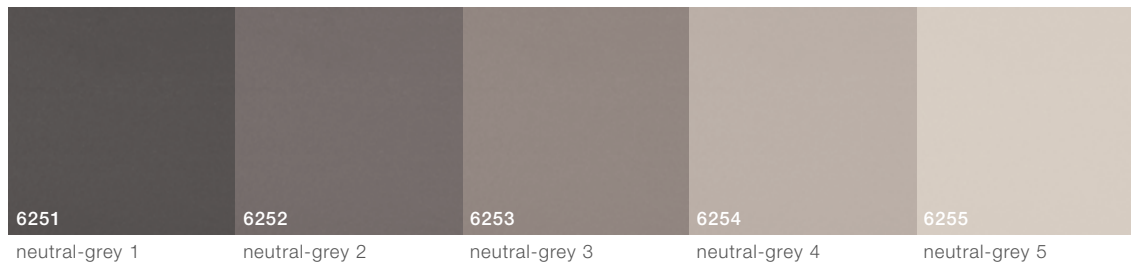

Design glazed

Stone

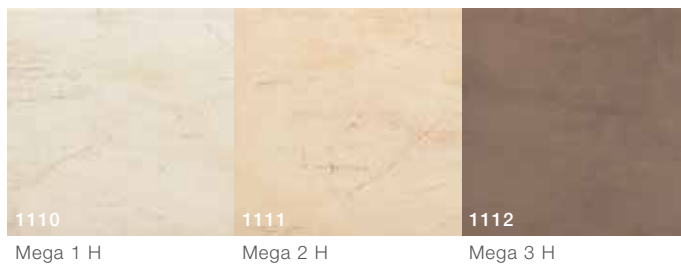
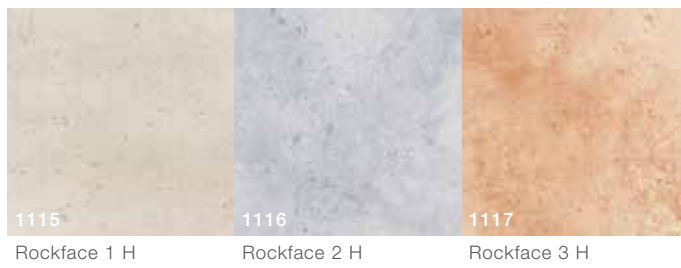
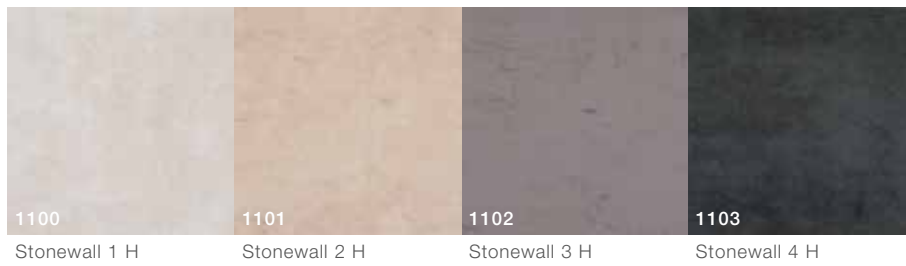

Wood

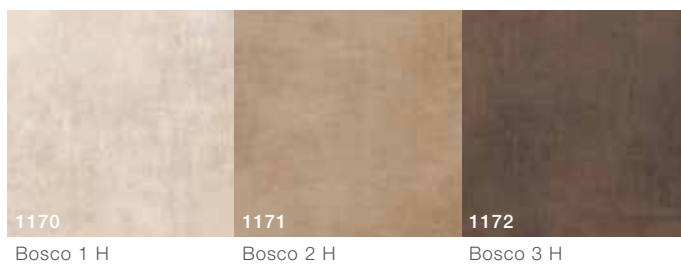

The colors "Design glazed" can be supplied for the system KerAion® up to a panel width of 60 cm. In addition to the variants shown, the production of individual articles is also possible. After a short check of the individual case for technical and economical feasibility, we will be pleased to provide you with project-specific information.

Cement

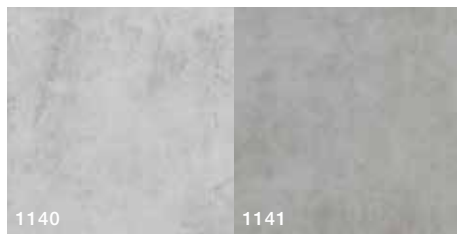

Construct 1 H Construct 2 H

Metal

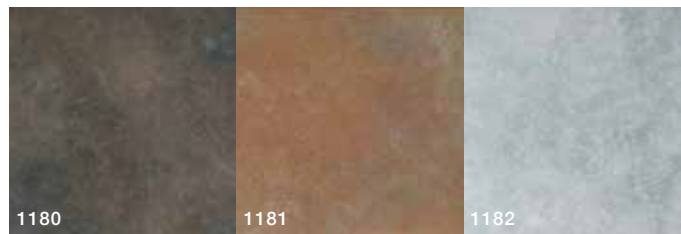

Metal 1 H Metal 2 H Metal 3 H

Contrasting colors, glazed, glossy



lemon-yellow H orange H apple-green H violet H contrasting red H intense blue H



H = Hytect surface

In addition to the variants shown, the production of individual articles is also possible. After a short check of the individual case for technical and economical feasibility, we will be pleased to provide you with project-specific information.

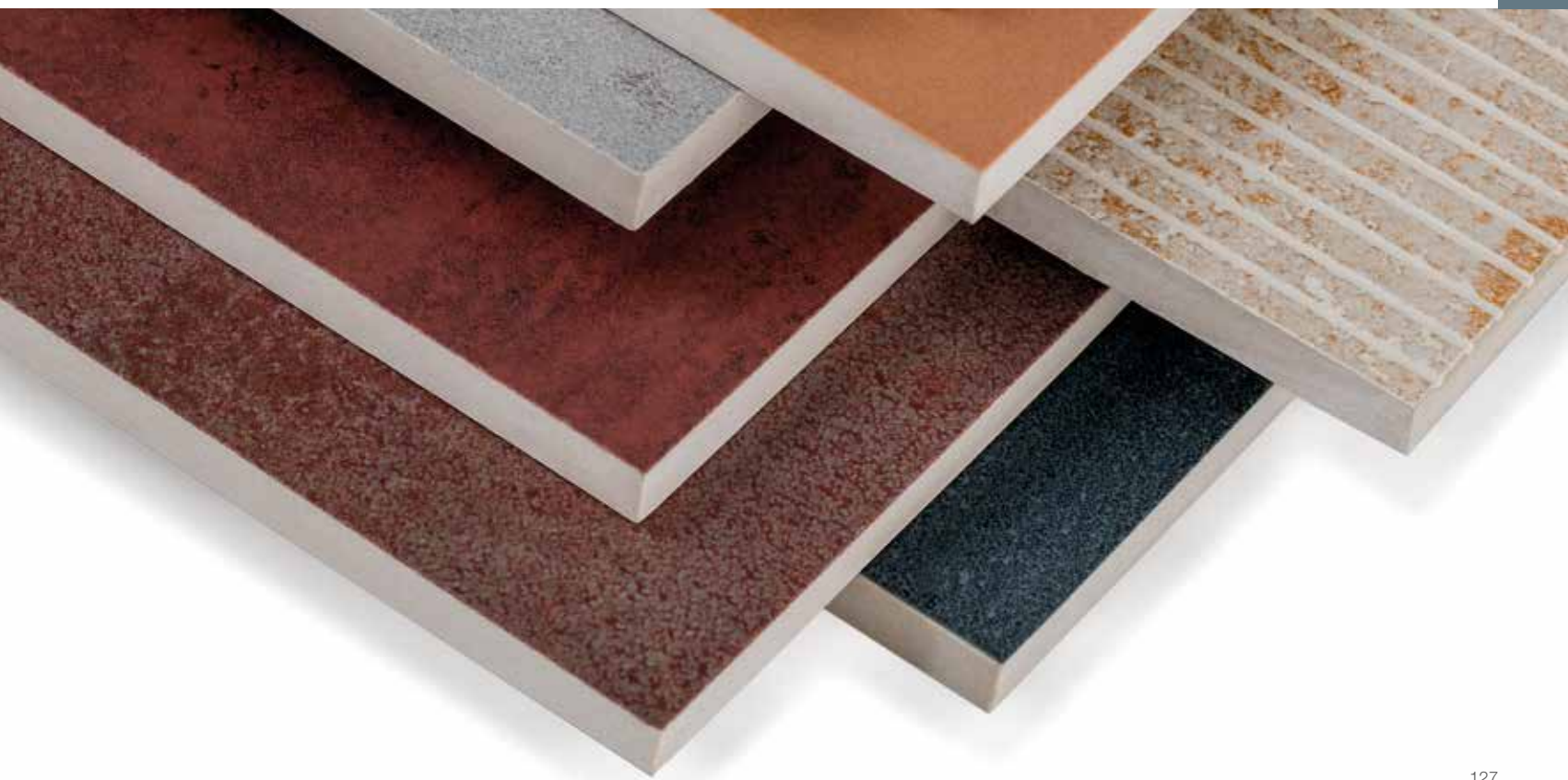

KerAion® K8 with visible clamp fastening

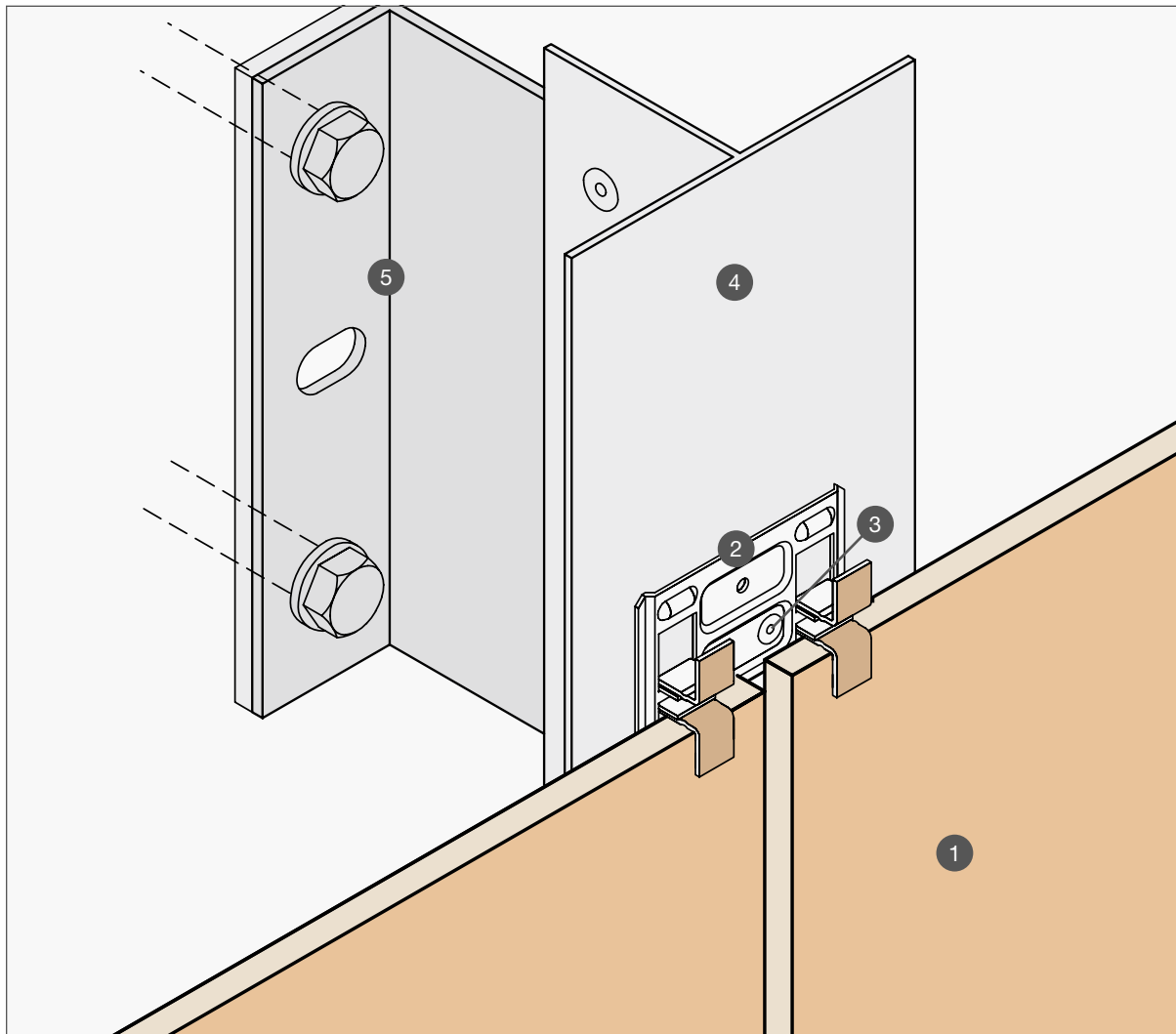

System description

The KerAion® facade panels are fixed on the substructure by means of the stainless steel clamps K8. The color of the clamp lips is matched to the panel design. To prevent clattering and constraining forces in the case of alternating wind loads, the facade panels are installed on the substructure in a nonrigid way by means of foamed pieces or alternatively with polyurethane.

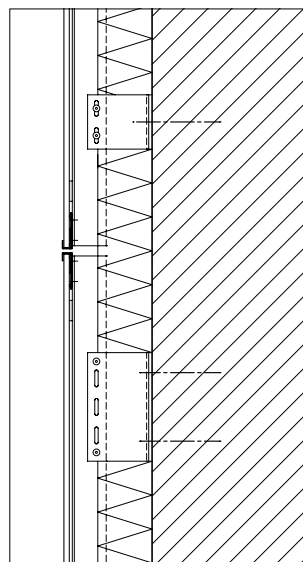

- 1 Facade panel KerAion® K8
- 2 Twin-clamp K8, article 545
- 3 Stainless steel blind rivet, article 675-01
- 4 Vertical bearing profile (basic substructure)
- 5 Wall bracket (basic substructure)



A profile butt joint of the vertical bearing profiles behind a panel is not allowed! See standard technical detail drawings.

Mounting instructions for KerAion® K8 with visible clamp fastening

Substructure

The mounting of the substructure must be carried out according to project-specific, static calculation. The usability certification Z-10.3-844 serves as basis.

- The profiles have to be mounted perpendicularly and in a flush way.
- The length of the profiles must be divisible by the height of the panel format and should not exceed the height of a storey of the building (approx. 3 m).
- A profile butt joint of the vertical profiles behind a panel is not allowed.
- The stainless steel clamps K8 (Art. no. 545, 546, 547, 548, 549) must be fastened with stainless steel rivets (Art. no. 675-01).
- For the nonrigid installation of the panels, foamed pieces or, alternatively, PUR or MS polymer bonding materials have to be used. Suitable products on request.

Accessories for KerAion® K8 with visible clamp fastening

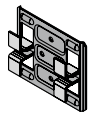

Article 545
Twin-clamp K8
Weight: 20 kg / 1,000 pieces
Perforation: 4 x 3.3 mm Ø
Base plate: painted black
Lips: painted similar to panel color
Material: 1.4571

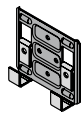

Article 546
Edge-clamp K8
Weight: 20 kg / 1,000 pieces
Perforation: 4 x 3.3 mm Ø
Base plate: painted black
Lips: painted similar to panel color
Material: 1.4571

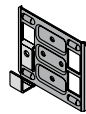

Article 547
Edge-clamp K8, left
Weight: 20 kg / 1,000 pieces
Perforation: 4 x 3.3 mm Ø
Base plate: painted black
Lips: painted similar to panel color
Material: 1.4571

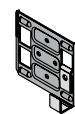

Article 548
Edge-clamp K8, right
Weight: 20 kg / 1,000 pieces
Perforation: 4 x 3.3 mm Ø
Base plate: painted black
Lips: painted similar to panel color
Material: 1.4571

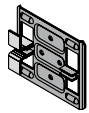

Article 549
Single-clamp K8
Weight: 20 kg / 1,000 pieces
Perforation: 4 x 3.3 mm Ø
Base plate: painted black
Lips: painted similar to panel color
Material: 1.4571



Article 675-01
Stainless steel blind rivet, black
Weight: 1.05 kg / box
Nominal dimensions: 3.2 x 9.5 mm
Box contents: 500 pieces
extended mandrel (58 mm)



Article 347-01
Foamed piece*
Weight: 1.80 kg / roll
Nominal dimensions:
20 x 30 x 8 mm
Roll: 1,380 pieces / roll
self-adhesive

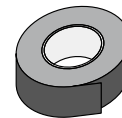

Article 506
Joint tape, black
Weight: 0.5 kg / roll
Nominal dimensions:
40 mm wide, 50 m
self-adhesive, weather-resistant

* Alternatively, nonrigid installation is also possible with PUR or MS polymer bonding materials. Suitable products on request.

Important: The use of silicone caoutchoucs must be absolutely avoided, because silicone fluids segregate and effect sticky surfaces on which dirt adheres. Therefore, only use the system components mentioned (foamed pieces, EDPM rubber profile, neoprene rubber washer) and pointing, bonding and sealing materials recommended by us. We will be pleased to inform you in detail. The usual final cleaning after completion of the construction works is still required.

KERAJOIN®

Ceramics in composite systems





Ceramics is a building material which has proved itself for thousands of years. However, it experienced its heyday in Germany in the 50s, during reconstruction. As a result, many planners and architects in Germany still associate building ceramics with this period. Rightly – and also wrongly.

Because with the further development of ceramic thermal insulation composite systems (ETICS), a true renaissance for ceramics has begun. Experts even assume that new guidelines for facade insulation will increase the importance of ETICS in the coming years. With KeraJoin®, such as e.g. the Craft series, exceptionally aesthetic ceramic products are available to architects and planners today. It permits great creative freedom. Because KeraJoin® offers an almost inexhaustible range of colors, a wide variety of gloss levels and diverse possibilities for project-specific individual solutions. In addition, AGROB BUCHTAL supplies products perfectly matched to ETICS of other manufacturers as surface covering.



Fritz Tower, Berlin, Germany / Architect: Sauerbruch
Hutton, Berlin / Year: 2020 /
Products: Craft / project-specific individual production
Photos: Jochen Stüber

A special feature of KeraJoin® are its three-dimensional surfaces. They lend both new and renovated buildings character. This is shown, for example, by the Vivendra Foundation project, for which the Swiss L3P office is responsible. Depending on the incidence of light and the position of the observer, the three-dimensional elements of the Craft series again and again put the building renovated in 2015 in a surprisingly new light.

The small-sized strip tile look of KeraJoin® visually ties in with the aesthetics of brick facades, which is very popular today. Thus, it is no wonder that the architect Mareike Beumer from the L3P office even secured her choice of material by visiting historic tile facades in Hamburg. Of the numerous advantages of the versatile building material ceramics, sustainability, longevity, aesthetics as well as color and light fastness were particularly relevant for her.

Vivendra Foundation, Dielsdorf, Switzerland / Architects: L3P Architekten
ETH FH SIA, Regensburg, Switzerland / Year: 2015 / Products: Craft
Photo: Adriano Faragulo





Residential and commercial building Badstraße,
Switzerland / Architects: Schoop Architekten AG,
Baden, Switzerland / Year: 2014 / Products: Craft
Photo: Adriano Faragulo



KeraJoin®

Fritz Tower

The facade of the high-rise apartment building designed by the architecture office Sauerbruch Hutton in the centre of Berlin sets design standards. Glued to a thermal insulation composite system, it consists of only three ceramic elements from AGROB BUCHTAL's "Craft" series: a three-dimensional "V-pointed profile strip tile" in ochre-yellow and muted white as well as specially manufactured nosing tiles for the corners of the building.

The new Lehrter Straße quarter is located just a few hundred metres north of Berlin's main railway station. It was developed over the last seven years on the basis of an urban master plan of the architecture office Sauerbruch Hutton and has transformed a former wasteland into a vital residential quarter with around 1,000 rental and owner-occupied flats. The architects developed a building structure consisting of six- and eight-storey individual buildings which are arranged in a zigzag row along a railway line. Situated at Quartiersplatz with shops and pubs, the Fritz Tower marks the geographical and collective centre of the new quarter, which is visible from afar. The high-rise apartment building with both 8 and 18 storeys houses a total of 266 micro-apartments of between 21 and 47 m². In addition, the building offers amenities such as a concierge service, a co-working space, an in-house gym and a public bistro.

The ochre-yellow ceramic facade, which clearly stands out from the plaster facades of the neighbouring houses, catches the eye even from a distance thanks to its unobtrusive gloss. Anyone approaching the Fritz Tower from Lehrter Straße via Quartiersplatz will see a slender high-rise building which rises evenly with windows elegantly designed around the corner and horizontal metal strips repeated every two storeys. "In a pleasant contrast to this uniformity are the irregular light reflections which give the homogeneous building envelope an ever-changing appearance depending on the viewpoint, incidence of light and time of day", explains Louisa Hutton.

The facade is also given a certain lightness by the many short white stripes which condense into long vertical lines in the plinth area, thus contributing to visually anchor the high-rise building in the ground without any change of material.



Fritz Tower, Berlin, Germany / Architect: Sauerbruch Hutton, Berlin / Year: 2020 / Products: Craft / project-specific individual production
Photos: Jochen Stüber



KeraJoin®



Apartment building Leopold, Sursee, Switzerland
Architect: GKS Architekten Generalplaner AG / Year: 2018
Products: Craft / Photos: Adriano Faragulo





De Korenbloem, Kortrijk, Belgium / Architect: Sergison Bates architects Atelier Kanal
Year: 2019 / Products: Craft / Photos: Marcel van der Burg



Sonnenhof, Wil, Switzerland / Architect: Meier Hug Architekten AG, Wil, Switzerland
Year: 2014 / Products: Craft / Photos: Adriano Faragulo

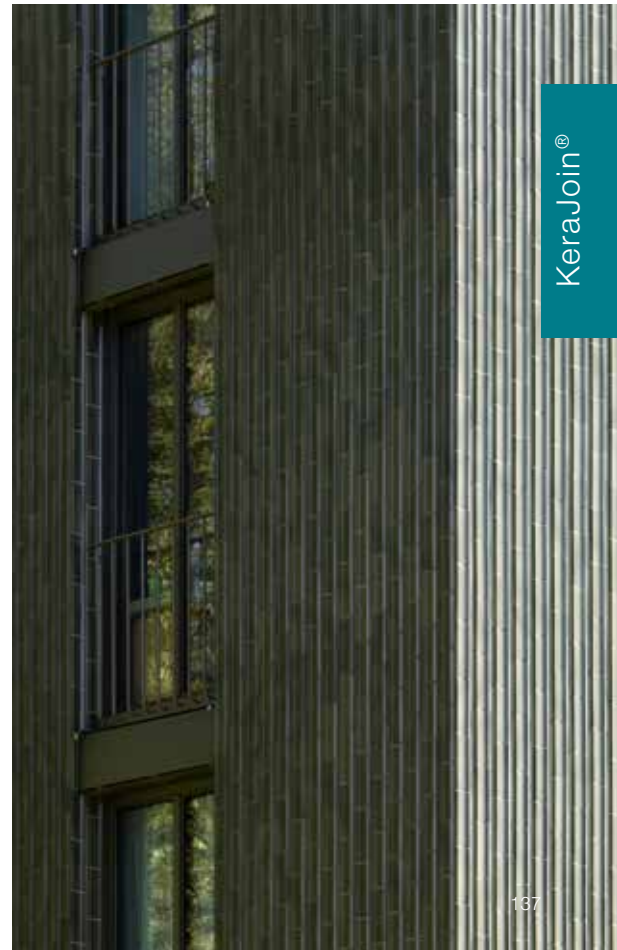



Housing complex Bellaria, Zurich, Switzerland / Architect: Michael Meier und Marius Hug Architekten AG, Zurich, Switzerland / Year: 2021 / Products: Craft Extended
Photos: Adriano Faragulo



Grätzelmixer, Vienna, Austria
Architect: KABE Architekten ZT-GmbH,
Vienna, Austria / Year: 2019 / Products: Craft
Photos: Fotodesign Peters, Amerang



School and sports facility Ried, Köniz, Switzerland / Architect:
Büning-Pfaue Kartmann Architekten GmbH, Basel, Switzerland
Year: 2020 / Products: Craft / Photos: Adriano Faragulo



KERAYOU®

More than just standard

AGROB BUCHTAL sees its most important task in offering architects and planners the design scope which they need for the realization of their creative ideas.

With approximately 20,000 glaze color recipes and an enormous variety of formats and surface structures, the company meets this requirement in most of all cases. However, AGROB BUCHTAL shows its true strength whenever innovative architectural concepts require an individual production. For the Design Department, the Product Management and the In-House Planning Department, the development of project-specific special solutions in co-operation with architects as partners is part of the core business.

This not only applies to special formats or colors corresponding to the ideas of the planner – or the CD specifications of a company. Innovative techniques such as photographic and screen printing methods, which permit the transfer of complex artworks onto ceramics, open up new horizons for creative facade design. Artists which – in agreement with the architect – wish to actively participate in the realization of their creations are welcome at AGROB BUCHTAL. And also special solutions which have not been mentioned here (so far) are checked for their feasibility in an unbureaucratic manner – as soon as the creative concept of an architect requires new solutions.



New QEII



Queen Elizabeth Hospital London, Great Britain / Architect: Penoyre & Prasad LLP
Year: 2015 / Products: KeraTwin®, special colors / project-specific individual production / Photo: Tim Crocker

KeraYou®

Integrative building project: showing character

The municipal plot between the Jewish Museum, the new TAZ building and the former Flower Wholesale Market Hall in Kreuzberg was not simply awarded to the highest bidder, but to the one who submitted the best concept for a development. This procedure alone distinguishes the "Integrative Building Project at the former Flower Wholesale Market" (IBeB) from most other German residential buildings. Another unique feature is the fact that an association of Selbstbaugenossenschaft Berlin (building co-operative) and the ifau | Heide & von Beckerath team of architects was responsible for the project development.

The three-dimensional ceramic elements from the Craft series specially produced for the ETICS facade give the building an unmistakably three-dimensional appearance. The main goal of the concept-based award procedure applied here was to achieve a high degree of diversity and a good mix of residents and uses. Accordingly, the new building not only has co-operative residential, studio and common spaces, but also owner-occupied studios and flats, commercial premises as well as space offered by the Protestant Community Association of the Deaf in Berlin.

Not least thanks to this forward-looking model, it was possible to build a house which – with the maximum possible interpretation of the development plan – forms, as it were, a city within the city. A look inside the flats, studios and access routes shows that in the IBeB primarily exposed concrete, metal and wood surfaces dominate the overall picture. For the building envelope, the architects were looking for a building material which would not only appear robust, handcrafted and natural, but at the same time do justice to the special location of the building. The 157 x 158 mm ceramic elements used to clad the mineral ETICS facade correspond to the architects' design ideas in many respects.

"We wanted to create a facade made of a material which should be neither light nor dark and also contribute to the quality of the urban space", says Carolin Gyra, project architect at the architecture office Heide & von Beckerath. With the medium-grey glazed ceramic elements from the Craft series specially developed by the architects and AGROB BUCHTAL for this project, both goals are achieved - a facade made of thousands of pixels which appear sometimes light and sometimes dark, depending on the point of view. The shimmering effect of the identical pixels is partly due to the slightly iridescent colors of the ceramic elements, which are traditionally fired in the tunnel kiln.



Integrative building project at the former Flower Wholesale Market (IBeB), Berlin, Germany
Architect: ARGE ifau | Heide & von Beckerath / Year: 2018
Products: Craft / project-specific individual production
Photos: Jochen Stüber





KeraYou®

Dwelling house on four “legs”

The Tiny House at the Floriade in Almere immediately catches the eye of visitors. From a distance, it looks like an Imperial runner from the Star Wars saga. Standing directly in front of it, it looks like an animal evolution from Jurassic Park. This is mainly due to the striking facade in shimmering brown and copper shades. It is reminiscent of the scaled skin of a giant fossil and consists of triangular ceramic tiles from AGROB BUCHTAL. The artist Christine Jetten has refined them with a special glaze.

The Rebel House by architect Cas van der Zanden is a small residential house which breaks with conventions: sustainable in terms of materials and special in terms of format. Cas usually works with prefabricated CLT (Cross Laminated Timber) panels in the case of facades. But this time it didn't work out with the cross laminated timber. Fortunately, he met Christine Jetten. The ceramics artist and the architect have fond memories of their collaboration.

It was agreed that ceramics with a fine dust glaze would be a perfect match for the sustainable concept and the look of The Rebel House. The fine dust is captured from the city air and recycled. At first they wanted to make the prototypes themselves and then look for a producer. No time. Fortunately, Christine remembered projects she had realized with architectural ceramics from AGROB BUCHTAL. "I design customized ceramic glazes for building facades and interiors which are not commercially available. Therefore, I know about the material quality and was immediately enthusiastic about the idea of using unglazed tiles from AGROB BUCHTAL for the design. The team made it possible within a very short time, it worked out great."

Cross-glued pine wood is the basis for the facade, floors and roof. Additional wood fibre boards with 8 mm joints serve as insulation. A 4 mm thick plaster layer of hydraulic lime is

applied onto the boards. This allows the house and the facade to breathe. The applied ceramics is also breathable and provides additional protection against heat loss. The choice fell on the 30 x 30 cm and 8 mm thick unglazed extruded stoneware tiles from AGROB BUCHTAL. The glaze developed by Christine Jetten was applied on them by a specialist company.

One sticking point was the asymmetrical, acute-angled shape of the ceramic triangles or "animal scales". For the trimming, a specialist company used water-jet technology with high pressure. Conventional methods would have created too much tension, causing the long, pointed triangles to break. About 60 m² of tiles were laid for the outer skin of the rebellious "dwelling animal". The pattern was complex and challenging for the tiler. Therefore, the architect projected the facade pattern onto the little house. In this way, The Rebel House could be transported to Almere in time for the opening of the Floriade.

Christine Jetten has made an international name for herself with her special glazes. She prefers to work closely with architects and the ceramics industry. She wants to contribute to more and more architects and students using the durable and robust building material and incorporating it into their design concepts from the very beginning.





KeraYou®



The Rebel House, Almere, the Netherlands / Architect: Cas van der Zanden
Year: 2022 / Products: KeraShape® special production / Photos: EuroParcs

Creating space for art

At the modernization of the Tate St. Ives Art Gallery by Jamie Fobert Architects in 2017, the color focus of the extension building, which is only minimally visible, just as the upper floors of Peacock House primarily was on blue shades which pick up the changeable weather in Cornwall and the colors of the sea behind it.

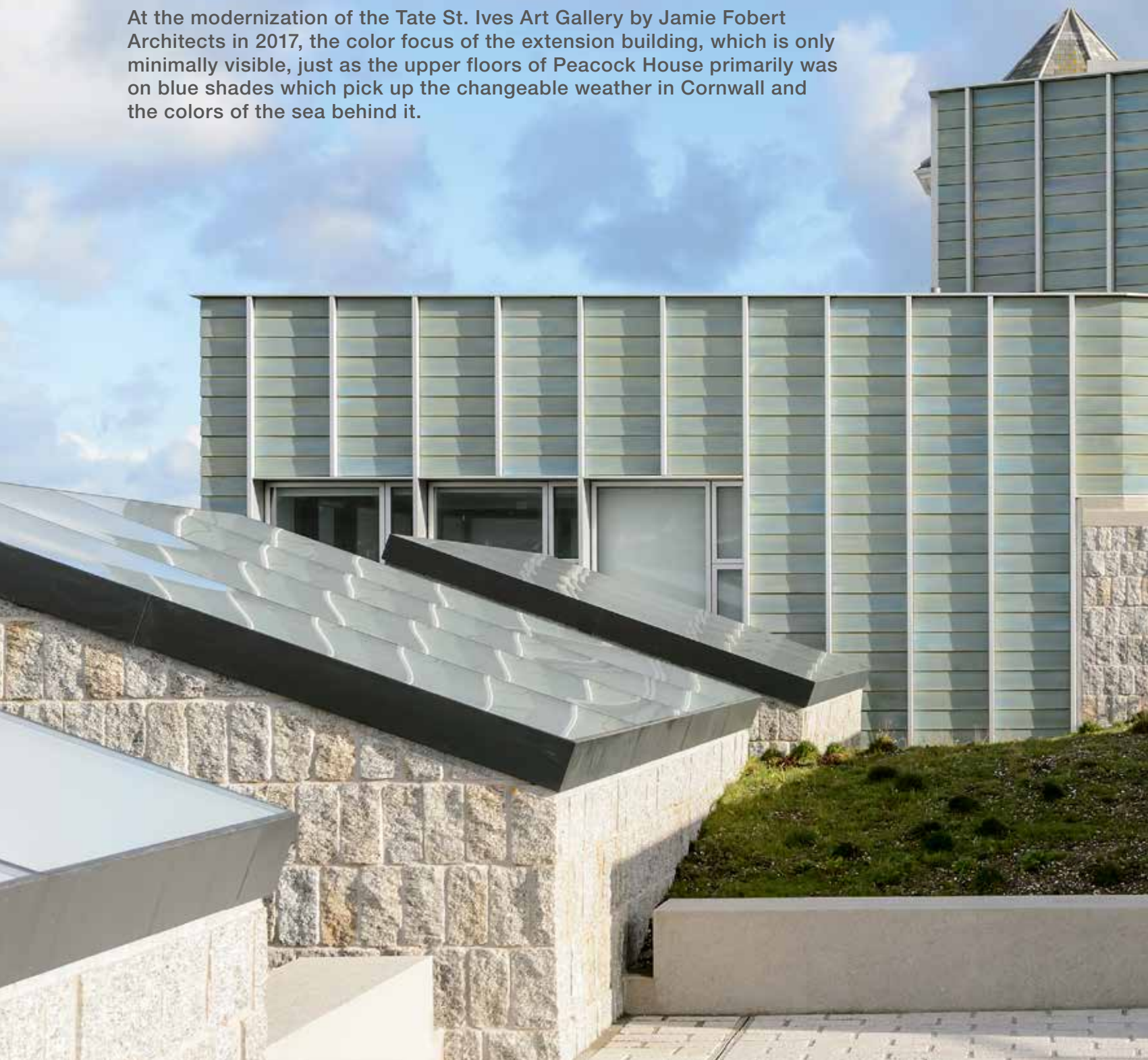

Tate St. Ives Gallery, St. Ives, Great Britain / Architect: Jamie Fobert Architects, London, Great Britain / Year: 2017 / Products: KeraTwin® project-specific individual production / Photos: Simon Hadley Photography, Pershore



The firm of Jamie Fobert Architects was commissioned to carry out a comprehensive renovation of the museum, which was designed in 1993 by the architects Evans & Shalev, and to extend it with a new gallery for contemporary art, an administrative wing with offices and training rooms as well as transition areas. Due to the highly competitive and sought-after location, a large part of the new building was set in the rocks, and only a relatively small part of the building – the smallest of the recent AGROB BUCHTAL projects – can be seen from the outside: the administrative wing with delivery zone for objects of art. In homage to the famous ceramic artists of St. Ives such as Bernard Leach, oblong, horizontally placed ceramic tiles from AGROB BUCHTAL adorn the outer shell of the building. Their glaze, which was subsequently applied and fired by a specialized company, causes the extension building, which is visible from the city, to almost disappear in the sunlight.





Tate St. Ives Gallery, St. Ives, Great Britain / Architect: Jamie Fobert Architects, London, Great Britain / Year: 2017 / Products: KeraTwin®
Photos: Simon Hadley Photography, Pershore

Service

Buildings which set standards can only evolve if the service is as good as the product. AGROB BUCHTAL has been committed to this idea for generations.

One of the best examples is represented by the In-house Planning Department which has been offering sound consulting and handling of routine tasks for more than 60 years and in partnerships based on collaboration, enabling architects and planners to concentrate fully on their creative tasks.

A quick summary of which facade system is suitable for which application is provided by the system overview on the following pages, supplying basic information on the possible applications for ceramic facade systems offered by AGROB BUCHTAL. Whether it's about the possible type of installation, suitability for certain bases or the accessories available – all of the details are summarized there and can be taken in in only a few glances.

GANĖDAGŖ
HALL

GANĖDAGŖ HALL

121

TRIPHAMMER ROAD

DAGQ:

Cornell University, Ithaca, New York, USA / Architect: IKON 5 Architects
Products: Design unglazed, KeraFace®, KeraTwin®, Natura unglazed / Photo: Jason Danzi

Overview and advantages: Fastening systems

KERATWIN®

Category

System profile

T-profile

Omega profile

OmegaV

System description

- Flexible pre-assembled height grid
- Very good assembly and adjustment possibilities thanks to separate basic and system profiles
- Wall connections (bracket or strut) can be used to achieve thermal and static requirements
- Used to achieve the required energy savings
- overhead assembly possible thanks to additional panel securing

- Flexible pre-assembled height grid
- Wall connections (bracket or strut) can be used to achieve thermal and static requirements
- Used to achieve the required energy savings
- overhead assembly possible thanks to additional panel securing

- Flexible pre-assembled height grid
- Lateral elongated holes permit tension-free assembly in terms of thermal linear deformation
- Easy assembly on studded wall partitions or smooth load-bearing surfaces
- overhead assembly possible thanks to additional securing brackets

- Horizontal profiles can be mounted on vert. constructions and on studded partition walls
- Horiz. panel heights can vary
- Offset formations are easy to realise
- Wall connections (bracket or strut) can be used to achieve thermal and static requirements
- Used to achieve the required energy savings
- overhead assembly possible thanks to additional panel securing

Possible installation methods

Horizontal, offset formation, overhead installation possible

Horizontal, offset formation, overhead installation possible

Horizontal, offset formation, overhead installation possible

Horizontal, free formation, overhead installation possible

Particularly suitable for the following wall structures

Fastening level:
- Solid wall constructions, e.g. masonry, concrete

Fastening level:
- Solid wall constructions, e.g. masonry, concrete

Fastening level:
- Skeleton constructions, e.g. studded partition walls, sandwich panels
- Solid wall constructions, e.g. concrete
- Static load-bearing

Fastening level:
- Skeleton constructions, e.g. studded partition walls, sandwich panels
- Solid wall constructions, e.g. masonry, concrete

Advantages for facade designers

- Very good assembly and adjustment possibilities thanks to separate basic and system profiles
- Fastening elements in the height grid are already integrated in the system profiles
- Easy assembly at connection points, e.g. corners, soffits etc.
- Very fast assembly of panels
- Easy to replace or subsequently install individual panels

- No basic profile required as the fastening elements are already integrated in the K20 T-profile height grid
- Exact assembly of the K20 T-profiles required
- Easy assembly at connection points, e.g. corners, soffits etc.
- Very fast assembly of panels
- Easy to replace or subsequently install individual panels

- Flexible fastening
- Tension-free fastening to smooth surfaces is possible
- Fastening elements are already integrated in the K20 Omega profile height grid
- Easy assembly at connection points, e.g. corners, soffits etc.
- Very fast assembly of panels
- Easy to replace or subsequently install individual panels

- Tension-free assembly of the horiz. supporting profiles thanks to oblong holes
- Flexible positioning of the K20 OmegaV profiles
- Very fast assembly of panels
- Easy to replace or subsequently install individual panels

Approvals

Z-10.3-844

Z-10.3-844

Z-10.3-844

Z-10.3-844

Accessories available

System profiles, joint profiles, corner profiles, soffit profiles, joint spacers, fastening elements (screws or rivets)

T-profiles, joint profiles, corner profiles, soffit profiles, joint spacers

Omega profiles, joint profiles, corner profiles, soffit profiles, joint spacers, fastening elements (screws or rivets)

OmegaV profiles, horizontal supporting profiles, joint profiles, corner profiles, soffit profiles, joint spacers, fastening elements (screws or rivets)

KERAION®			
OmegaS	Clamp system	K8 clamp fastening	Undercut fastening
<ul style="list-style-type: none"> - Flexible pre-assembled height grid - wall connections (bracket or strut) can be used to achieve thermal and static requirements - Used to achieve the required energy savings - K20 Omega profiles mounted in the single-beam element with cantilever arms - Exact horiz. alignment by OmegaS profiles - Overhead assembly possible thanks to additional panel securing 	<ul style="list-style-type: none"> - Wall connections (bracket or strut) can be used to achieve thermal and static requirements - Used to achieve the required energy savings - vert. installation of panels to max. format of 50 x 135 cm - Overhead assembly thanks to safe clamp fastening 	<ul style="list-style-type: none"> - Wall connections (bracket or strut) can be used to achieve thermal and static requirements - Used to achieve the required energy savings - Lightweight panels - Can be mounted on metal and wooden substructures 	<ul style="list-style-type: none"> - Wall connections (bracket or strut) can be used to achieve thermal and static requirements - Used to achieve the required energy savings - Lightweight panels - Can be mounted on metal and wooden substructures - Invisible fastening
Vertical	Horizontal, vertical, offset formation, overhead	Horizontal, vertical	Horizontal, vertical
<p>Fastening level:</p> <ul style="list-style-type: none"> - Skeleton constructions, e.g. studded partition walls, sandwich panels - Solid wall constructions, e.g. masonry, concrete 	<p>Fastening level:</p> <ul style="list-style-type: none"> - Skeleton constructions, e.g. studded partition walls, sandwich panels - Solid wall constructions, e.g. masonry, concrete 	<p>Fastening level:</p> <ul style="list-style-type: none"> - Skeleton constructions, e.g. studded partition walls, sandwich panels - Solid wall constructions, e.g. masonry, concrete 	<p>Fastening level:</p> <ul style="list-style-type: none"> - Skeleton constructions, e.g. studded partition walls - Solid wall constructions, e.g. masonry, concrete
<ul style="list-style-type: none"> - K20 Omega profiles mounted on vert. supporting structure - Exact alignment of the horiz. joints using OmegaS profiles - Safe fastening thanks to securing bracket - Very fast assembly of panels - Easy to replace or subsequently install individual panels 	<ul style="list-style-type: none"> - Easy fastening with well-conceived clamp system - Flexible fastening as each hole in the panel can be used - Slight "pulling" or "pushing" of the grid is possible - Easy to replace or subsequently install individual panels 	<p>Tried-and-tested panel assembly, low weight, can be cut on site using basic tools (glass cutter)</p>	<p>Tried-and-tested panel assembly, low weight, can be cut on site using basic tools (glass cutter)</p>
Z-10.3-844	Z-10.3-844	Z-10.3-776	ETA-21/0873
Omega profiles, joint profiles, joint spacers, securing brackets, OmegaS supporting profile, fastening elements (screws or rivets)	Clamps, joint profile, fastening elements (rivets, screws), joint tape	K8 clamps, joint tape, fastening elements (rivets)	Available through the system suppliers



From professionals for professionals: the In-House Planning Department

Facade design is a complex challenge which besides aesthetic aspects also raises many technical and physical questions – in addition to the unavoidable bureaucracy. The In-House Planning Department of AGROB BUCHTAL, which was already established more than 60 years ago, offers professional support, so that architects can exclusively concentrate on their creative ideas.

As AGROB BUCHTAL supplies high-quality products and competent services, planners and architects using the products can benefit from the know-how of a committed team of qualified technicians, engineers, designers and color

experts, which ensure a quick and problem-free realization of individual concepts. This also includes the concrete advice regarding application techniques, upon request on location.

In addition to their advisory capacity, these experts also carry out routine tasks, which would only be disturbing at the development of architectural visions. They include laying plans and determinations of quantities.

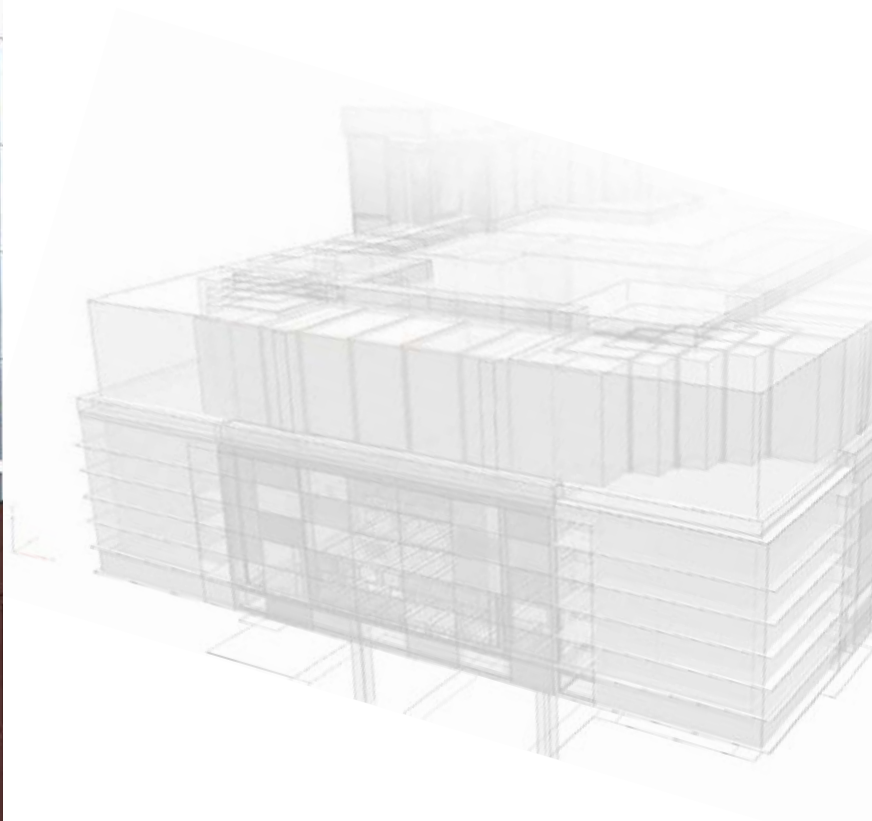



Technical data and test reports of our products as well as standards and regulations for facade claddings with ceramic panels you will find on our website at:

<https://facade.agrob-buchtal.de/en/downloads>



AGROB BUCHTAL GmbH
Buchtal 1
D-92521 Schwarzenfeld
Phone: +49 (0) 94 35-391-0
Fax: +49 (0) 94 35-391-34 52
E-Mail: info@agrob-buchtal.de
Internet: www.agrob-buchtal.de

You will find contact names for
other countries on the internet at:

www.agrob-buchtal.de

www.assenmacher.net



valid as of 10/2023, subject to modifications

The publisher assumes no liability for typographical errors. Color deviations to the original products may occur during the printing process.