

KAKKU HEAVY DUTY D.C ELECTRO – MAGNETIC BRAKES

SERIES KCH

SIMPLICITY

The KAKKU DC Electro-magnetic Brakes Series KCH are robust and simple in design having minimum No. of parts. All parts are sturdy, readily accessible and easily removable thus reducing maintenance problems and down time.

OVER THE WHEEL-DESIGN

The 'Over the wheel' pull rod design of KAKKU Brakes series KCH divides the braking force between the pull rod and pins while transmitting the braking force to the outer shoe lever. As a result, braking action is spread evenly over both the shoes providing maximum stopping power with minimum wear of the brake shoes. In this design, bearing wear is also minimised at the shoe levers because of large bearing area and close tolerance fit of the levers. There are no complicated linkages.

MAGNET

The magnet consists of two similar cast steel armatures, which in conjunction with the coil provides a powerful short stroke magnet system. The armature pivot at their base has a rigid support and shoulder pins. Adjustable plugs can be provided as an additional feature, which allows the residual magnetic gap to be increased to reduce brake application time. The adjustable torque spring is housed between the two armatures and the torque is adjusted by the torque adjusting nut. The magnet is effectively protected against the ingress of dust.

COIL

The epoxy filled class 'F' coil is encapsulated in sheet steel housing for complete environmental protection. The coil is mounted separately in between the two armatures so that it can be easily reversed with the terminals facing either way or towards the wheel, making cable connections extremely easy.

LINING

Shoe linings are made from asbestos based material, which has high coefficient of friction and low rate of wear. The linings are bolted to the shoes as standard and are easily replaceable.

SHOE ADJUSTMENT

Each shoe can be adjusted independently to compensate for the lining wear. The outer shoe is adjusted by a nut and the inner shoe

is adjusted by a bolt-operated sliding wedge. Both adjustments are locked. The adjustment of shoe travel can be done quite accurately. When the travel of the individual shoe is just right, sounding pins on the upper sides of armature are flushed with the surface of bushing in the de-energized condition. It is even recommended to adjust the shoe travel during operation.

SHOE POSITIONING

Brake shoe can be positioned to compensate for misalignment of brake to motor shaft/ drum thus easing installation. Once properly positioned, no further attention is required. Cap screws and gripping blocks rigidly secure them to brake shoe levers and prevent the shoes from tilting and riding the wheel when the brake is released.

TORQUE SETTING

The torque is set by turning the torque adjusting nut clockwise to a positive stop and then backing off a present number of turns to obtain rated torque.

ADAPTABLE TO AC APPLICATIONS

The shunt Brakes can be used with rectifier panel. This combination is for giving advantage of DC braking with AC power.

OPERATION

D.C Electro-magnetic Brakes Series KCH are electrically released and spring set. When the coil is energised the armatures are attracted together to compress the torque spring and move the shoes away from the wheel thus releasing the brake. De-energising the coil allows the torque spring to separate the armatures and press the shoes against the wheel, thus setting the brake and making it fail safe in the event of a power failure.

TYPE AND DUTY RATING

KAKKU D.C Brakes series KCH are basically of two types:

- 1) Shunt Brakes.
- 2) Series brakes.

SHUNT BRAKES

Shunt brakes have their coils separately energised from a DC source or AC source when used with rectifier. Shunt brakes are as under.

INTERMITTENT DUTY

One-hour duty with maximum torque available for a given size of brake. The coil

may be energised for one hour without overheating or the brake may be operated at 15%, 25% & 40% CDF.

CONTINUOUS DUTY

Continuous or 8 hour duty with 75% of the maximum torque available for a given size of brake. The coil is energised continuously without overheating or the brake may be operated at 60%/ 100% CDF of motors.

SHUNT BRAKE WITH RECTIFIER FOR AC OPERATION

In this combination, intermittent shunt brake torque ratings are obtained on continuous duty basis. That is, maximum torque corresponding to a given size of brake is available for continuous operation.

SERIES BRAKE

Series brakes have their coils in the armature circuit of a DC motor. These brakes are rated in amperes for half hour or one hour corresponding to rating of DC series motors. The recommend duties are

ONE HOUR OR MILL DUTY (O)

One hour with 65% or maximum torque available for a given size of brake. The coil may carry either motor FLC for one hour without overheating of the brake or the brake may operate on duty cycles of 50% CDF at motor FLC.

HALF HOUR OR CRANE DUTY (H)

Half hour duty with maximum torque available for a given size of brake. The coil may carry either motor FLC for half an hour without overheating or the brake may operate on the duty cycle of 30% CDF at motor FLC.

STANDARDS

- a) INCHES (I) :
AISE and NEMA ratings and dimensions in inch –Series KCH (I).
- b) METRIC (M/B) :
AISE ratings, metric size brake-Series KCH (M/B).

AISE and NEMA standards for mill brakes prescribe items such as wheel diameter and width, torque increments, height of wheel centre line, mounting dimensions etc. These standards also fix wheel offset, bores and mounting centre line between motor and the brake.



Symbol Of Reliability

BRAKE SELECTION

For most applications, the brake torque must be equal to or greater than motor full load torque as referred to the drum/ wheel shaft. Thus, Torque in Kg.m = $\frac{974 \times KW}{rpm}$

Where,

K W = motor output

rpm = revolution per minute

With torque requirement known, the type and the duty cycle established, the brake is selected accordingly from the selection table. For certain special application e. g. crane hoist and other overhauling loads, the brake should be capable of providing at

least 150% of the motor torque.

DIMENSIONS

For dimensional details, please refer to our drawings.

PRODUCT SPECIFICATIONS

Product Code	:	KCH (I) & KCH (M/ B)						
Size	Inches	8"	10"	13"	16"	18',19"	23"	
	Metric	200mm	250mm	300mm	400mm	500mm	600mm	
Energise (Release) time in sec. (approx.)	:	0.12	0.16	0.29	0.42	0.48	0.78	
De-Energise (set) time in sec (approx)	:	0.2	0.22	0.28	0.32	0.47	0.55	
Class of Insulation	:	Class 'F'.						
Insulation Voltage Ui	:	600V.						
Release Voltage for Shunt Coil	:	80% of Rated Voltage.						
Release Current for Series Coil	:	40 % of Rated Current.						
Brake set Voltage for Shunt Coil	:	More than 10% of Rated Voltage.						
Brake set Current for Series Coil	:	More than 10% of Rated Current.						
No. of Operations per hour	:	600 per hour						
Mechanical Life	:	20 X10 ⁶ operations.						
Finish of Brake	:	Grey.						

NOTES:-

- 1) The maximum number of operations of brakes is limited by the time required for the brake to operate and the energy dissipated per stop.
- 2) All brakes can be mechanically adjusted down to 50% of their maximum rated torque.

TORQUE RATING OF SHUNT BRAKES AS PER AISE

Inch	Brake Size		Torque Rating – D.C. Operation				Torque Rating – A.C. Operation	
	Millimetric		Continuous Duty		Intermittent Duty		Continuous Duty	
	(1)	(2)	lb.ft	Kg. mtr.	lb.ft	Kg. mtr.	lb.ft	Kg. mtr.
8	203.2	200	75	10.4	100	13.8	100	13.8
10	254	250	150	20.8	200	27.7	200	27.7
13	330.2	300	400	55.5	550	76.0	550	76.0
16	406.4	400	750	104	1000	138.3	1000	138.3
19	482.6	500	1500	208	2000	277	2000	277
23	584.2	600	3000	416	4000	555.3	4000	555.3
30	762.0	800	6000	832	9000	1248	9000	1248

(1) This column is mere conversion of inch to mm.

(2) This column is the nearest equivalent size of mm brake.



Symbol Of Reliability

CODES

Shunt Brakes	:	S	Series Brakes	:	E
Continuous Duty	:	C	Half Hour Duty	:	H
Intermittent Duty	:	I	(Crane Duty)		
Supply Voltage	:		One Hour Duty	:	O
1) 230V DC	:	1 240V 50 Hz – 3	(Mill Duty)		
2) 460V DC	:	2 415V 50 Hz – 4	Example	:	KCH-8 E

CURRENT RATING FOR SERIES BRAKES

Size	½ Hour Duty		1 Hour Duty		Size	½ Hour Duty		1 Hour Duty	
	Current Rating Amps	Code	Current Rating Amps	Code		Current Rating Amps	Code	Current Rating Amps	Code
8"/200mm	29	1	21	3	16"/400mm	245	1	185	3
	44	2	31	4					
10"/250mm	57	1	40	3	19"/500mm	368	1	272	3
	77	2	57	4			500	2	360
13"/300mm	126	1	95	3	23"/600mm	740	1	540	3
	175	2	132	4			960	2	730

TORQUE & CURRENT RATINGS OF SERIES BRAKES

Inch	Brake Size		Motor Frame Size AISE	Half Hour Rating			One Hour Rating		
	Millimetric			Max. Rated Torque		Max. FLC Amps.	Max. Rated Torque		Max. FLC Amps.
	(1)	(2)		lb.ft	Kg. mtr.		lb.ft	Kg. mtr.	
8	203.2	200	402, 802A 403, 602, 802B	100	13.8	29 44	65	8.9	21 31
10	254.0	250	404, 603, 802C 406, 604, 803	200	27.7	57 77	130	18	40 57
13	330.2	300	408, 606, 804 410, 608, 806	550	76	126 175	365	50.5	95 132
16	406.4	400	412, 610, 808	1000	138.3	245	650	89.8	185
19	482.6	500	414, 612, 810	2000	277	368 500	1300	180	272 360
23	584.2	600	418, 616, 814 618, 816	4000	555.3	740 960	2600	360	540 730

(1) This column is mere conversion of inch to mm.
 (2) This column is the nearest equivalent size of mm brake.

COIL AND RESISTANCE DATA – SHUNT BRAKES

Size		Intermittent Duty					
Inch	mm	230 V D.C.			460 V D.C.		
		Coil (Ω)	Permanent (Ω)	Coil (Amps.)	Coil (Ω)	Permanent (Ω)	Coil (Amps.)
8	200	43	80	1.9	---	---	---
10	250	40	64	2.17	195	336	0.8
13	300	28	52	2.86	130	336	0.9
16	400	27	38	3.56	110	160	1.8
19	500	15	28	5.33	65	112	2.54
23	600	12	16	8.35	46	120	2.9

Size		Continuous Duty						240 V* AC		415 V* AC	
Inch	mm	230 V D.C.			460 V D.C.			Permanent (Ω)	Economy (Ω)	Permanent (Ω)	Economy (Ω)
		Coil (Ω)	Permanent (Ω)	Coil (Amps.)	Coil (Ω)	Permanent (Ω)	Coil (Amps.)				
8	200	142	160	0.81	---	672	0.33	0	80	64	160
10	250	99	132	1.01	195	560	0.45	0	80	64	132
13	300	45	80	1.87	130	325	1.00	16	32	64	80
16	400	43	64	2.12	110	304	1.1	0	40	40	64
19	500	37	62	2.59	65	---	---	0	32	32	32
23	600	29	38	3.44	46	---	---	0	23	20	40

* For AC applications data corresponding to 230V DC continuous duty coil only referred.

Product improvement is a continuous process at KAKKU. Hence data given in this catalogue is subject to revision without notice.



Symbol Of Reliability

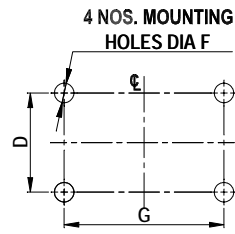
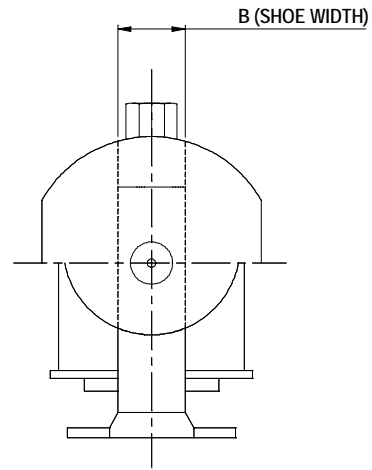
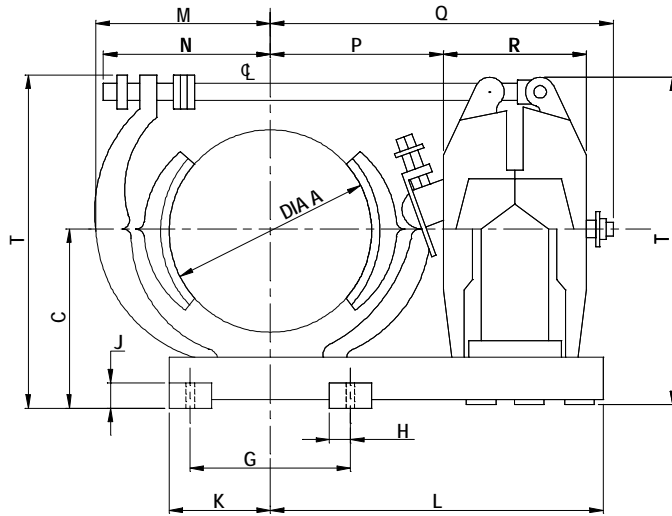
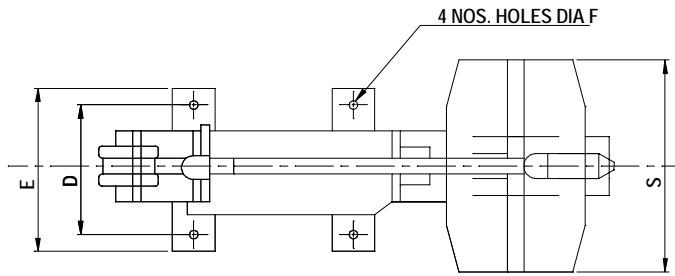

MOUNTING DETAILS

Brake Type	Drum Dia mm	Max. Rated Torque (Kg M)
KCH-200	200	13.8
KCH-250	250	27.7
KCH-300	300	76.0
KCH-400	400	138.3
KCH-500	500	277.0
KCH-600	600	555.3

Brake Type mm	A mm	B mm	C mm	D mm	E mm	F mm	G mm	H mm	J mm	K mm	L mm	M mm	N mm	P mm	Q mm	R mm	S mm	T mm
KCH-200	200	80	170	60	121	17.4	350	19	50	194	406	166	164	209	417	181.0	242	338
KCH-250	250	88.9	212.7	158.7	196.8	17.5	203.5	19	19	130.2	422.3	203.2	200	219.1	431.8	187.3	273.1	400
KCH-300	300	140	240	80	165	22.2	500	25	68	275	514	239	238	284	524	216	331	480
KCH-400	400	165.1	320	90	184	25	340	25	57	195	538	311	305	315	556	216	381	590
KCH-500	500	216	400	100	400	25	410	64	32	280	652	377	360	386	683	257	458	716
KCH-600	600	279.4	475	126	484	38	500	72	30	350	742	469	418	448	783	289	522	844



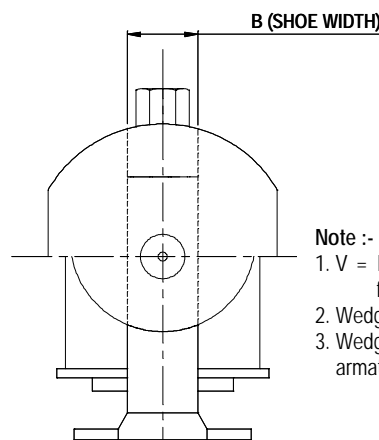
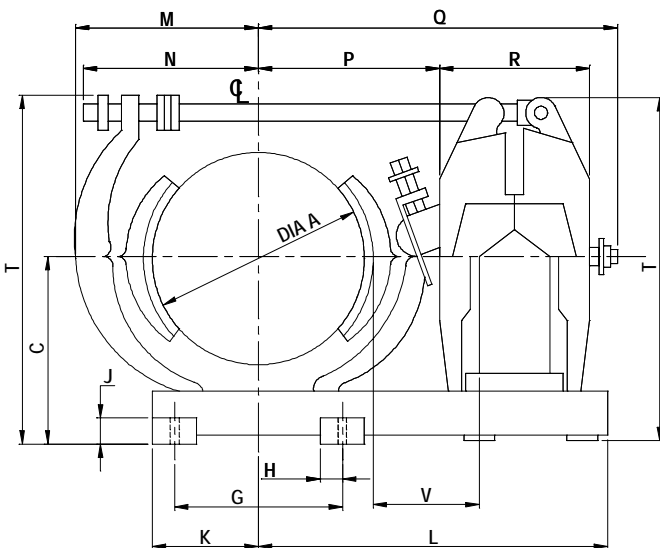
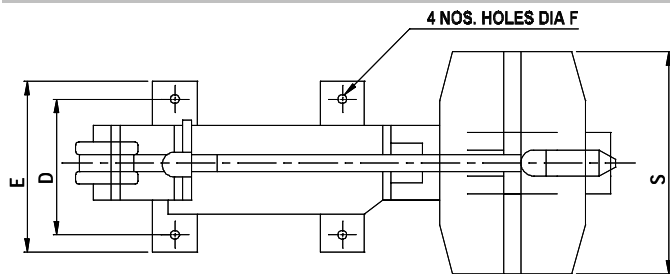

Note :-

1. V = Distance from Brake drum face to coil edge.
2. Wedge block 19mm below stop.
3. Wedge block is placed between armature and shoe lever.

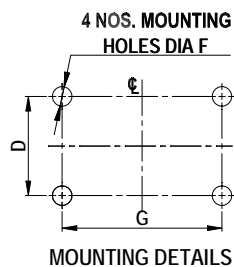

Brake Type	Drum Dia (Inch)	Drum Dia (mm)	Max. Rated Torque (Kg M)
KCH-8	8	203.2	13.8
KCH-10	10	254.0	27.7
KCH-13	13	330.2	76.0
KCH-16	16	406.4	138.3
KCH-19	19	482.6	277.0
KCH-23	23	584.2	555.3

Brake Type INCH	A mm	B mm	C mm	D mm	E mm	F mm	G mm	H mm	J mm	K mm	L mm	M mm	N mm	P mm	Q mm	R mm	S mm	T mm	Max. V Min. mm
KCH-8	203.2	79.37	177.8	146.05	184.15	17.46	165.1	15.87	20.63	107.95	381	165.1	165.1	187.32	390.52	180.97	241.3	346.07	115.88 122.23
KCH-10	254	88.9	212.72	158.75	196.85	17.46	203.2	19.05	19.05	130.17	422.27	203.2	200.02	219.07	431.8	187.32	273.05	400	125.01 131.36
KCH-13	330.2	139.7	250.82	228.6	279.4	20.63	292.1	22.22	19.05	177.8	495.3	250.82	241.3	263.52	504.82	215.9	330.2	487.6	148.82 155.17
KCH-16	406.4	165.1	307.97	273.05	330.2	26.98	381	25.4	23.81	215.9	536.57	311.15	304.8	314.32	555.62	215.9	381	577.85	157.95 164.30
KCH-18	457.2	215.9	336.55	330.2	400.05	26.98	469.9	31.75	33.33	266.7	638.17	368.3	368.3	377.82	673.1	257.17	457.2	650.87	205.58 211.93
KCH-19	482.6	215.9	336.55	330.2	400.05	26.98	469.9	31.75	33.33	266.7	638.17	368.3	368.3	377.82	673.1	257.17	452.2	650.87	205.58 211.93
KCH-23	584.2	279.4	403.22	406.4	482.6	33.33	596.9	38.1	33.33	336.55	730.25	460.37	425.45	441.32	771.52	289.92	520.7	771.52	234.15 240.5

Electronic & Power Control Co.
(AN ENTERPRISE OF KAKKU E & P CONTROL (P) LTD.)
1, Industrial Estate, Bhilai 490 026,
(Chhattisgarh) INDIA.



Tel : 91-788-2382610, 2382297
Fax : 91-788-2381797, 2321836
E-mail : kaku_bhilai@yahoo.com

Symbol Of Reliability