



Li-ion Battery Powered 

Counterbalanced Forklift

FPB25M SERIES - 5000lbs

Pneumatic Tires

- ✓ Better operator comfort and controllability
- ✓ Standard components for easy service and maintenance
- ✓ Lithium battery for longer run-time and improved productivity
- ✓ Enhanced environmental friendliness and increased economy

CHARACTERISTICS

480 VOLT / 3 PHASE

POWER AND PERFORMANCE

Green:

- Zero emission, pollution-free

Productivity:

- Easy and fast charging, suitable for multi-shift operation

Maintenance free and Reliability:

- High power conversion efficiency
- Lower overall operation cost
- 4000 times charge-discharge cycles
- 80 Volt / 3 Phase / 480 Service
- More than 8 years of service



Model	Battery Capacity (Kwh)
FPB25M-3	80V/205Ah, 16.4Kwh (142kg)
FPB25M-5	80V/230Ah, 18.4Kwh(148kg)
FPB25M-7	80V/410Ah, 32.8Kwh (261kg)
FPB25M-9	80V/460Ah, 36.8Kwh (274kg)
FPB25M-11	80V/205Ah, 16.4Kwh (142kg)
FPB25M-13	80V/230Ah, 18.4Kwh (148kg)
FPB25M-15	80V/410Ah, 32.8Kwh (261kg)
FPB25M-17	80V/460Ah, 36.8Kwh (274kg)

FPB25M SERIES FEATURES & COMPARISONS

STANDARD FEATURES:

- 3 stage full free lift mast (189" Max Height)
- 42" forks
- 4VS control valve
- Back-up alarm and strobe lamp
- Head lamps and rear lamps
- Orbitrol power steering
- Solid pneumatic tires. Front 7.00x12 / Rear 6.00x9
- Suspension seat/ 60" retractable seat belt
- Protective canopy cover for inclement weather.

Series Comparison Chart	FPB25M-3	FPB25M-5	FPB25M-7	FPB25M-9	FPB25M-11	FPB25M-13	FPB25M-15	FPB25M-17
Cascade fork positioner and side shifter					✓	✓	✓	✓
Electric 80 volt 205A/H Eikto lithium battery. 3-4 hours of working time. 10% left max full charge 3.15 hours	✓				✓			
Electric 80 volt 230A/H Eikto lithium battery. 4-5 hours of working time. 10% left max full charge 2.3 hours		✓				✓		
Electric 80 volt 410A/H Eikto lithium battery. 6-7 hours of working time. 10% left max full charge 2.05 hours			✓				✓	
Electric 80 volt 460A/H Eikto lithium battery. 8-9 hours of working time. 10% left max full charge 2.3 hours				✓				✓
80 volt 100 a/h charger		✓				✓		
80 volt 200 a/h charger			✓	✓			✓	✓
80 volt 65 a/h charger	✓				✓			

STANDARD FEATURES & COMFORT



Wide step for easy entry, and spacious leg & foot room.



Ergonomic seat for a smoother and more comfortable drive.



Adjustable steering column according to operator's preference to reduce fatigue.



Wide view mast offers good driving vision.



Ergonomically placed foot pedals, easy to use.



Easy opening charging side door.



OPS: preventing accidents and keeping workers in the operating areas safe.



Blue spot light: reminding pedestrians when reversing.



Back-up handle with horn button; improving both driver's comfort and reversing safety.

INTELLIGENT DISPLAY

The intelligent LED instrument panel shows forklift status

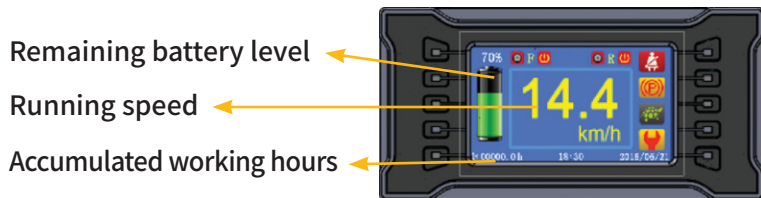

Remaining battery level

Running speed

Accumulated working hours

RELIABLE CONTROLLER

ZAPI controller combines the performance of lithium battery management system with the forklift to create a perfect driving experience.



IBMS (INTELLIGENT BATTERY MANAGEMENT SYSTEM)

- **RT Status:**

Report the forklift status in real-time

- **RUN log:**

Monitor the forklift run trend

- **DEV info:**

Easily get the battery information for check and inspect.

Detect the battery with your phone Any time & Anywhere.

LI-ION BATTERY POWERED FORKLIFT TRUCK FBP25M SERIES (PARAMETER AND PERFORMANCE)

Characteristics	1	Manufacturer		Unit	HELMAR	
	2	Model			FBP25M Series	
	3	Load Capacity		lbs.	5,000	
	4	Load Center		Inches	19.6875"	
	5	Power Type			Electric	
	6	Wheels (x = driven)	Front / Rear		2x/2	
Dimensions	7	Maximum Fork Height (A)		Inches	9' 10"	
	8	Free Lift Height		Inches	4' 4"	
	9	Fork Size (K, M, L)	L x W x T	Inches	42 1/8 x 4 3/4 x 1 5/8	
	10	Tilt Angle	Fwd. / Bwd.	deg.	6/12	
	11	Length to Fork Face (D)		Inches	100 19/32	
	12	Overall Width (E)		Inches	45 1/4	
	13	Mast Height Fork Lowered (F)		Inches	79 15/16	
	14	Mast Height Fork Raised (H)		Inches	158 5/8	
	15	Overhead Guard Height (G)		Inches	81 1/2	
	16	Operator's Seat Height		Inches	41 9/64	
	17	Turning Radius (C)		Inches	88 3/16	
	18	Load Distance (Centerline of front axle to front face of forks)		Inches	17 3/4	
	19	Basic Right Angle Stacking Aisle Width (Add load length and clearance)		Inches	157 9/32	
Performance	20	Travel, Max.	Full Load	mph	8.69	
	21		No Load	mph	9.32	
	22	Lifting	Full Load	inches/sec	17 3/4	
			No Load	inches/sec	19 5/8	
	23	Lowering	Full Load	inches/sec	17 3/4	
			No Load	inches/sec	21 5/8	
	24	Max. Gradeability		Full Load	%	20
				No Load	%	20
Total Weight				lbs.	8,158	
Chassis & Wheels	27	Tires	Number	Front / Rear	2/2	
	28		Size	Front	7.00-12-12PR	
	29		Rear	6.00-9-10PR		
	30	Wheelbase(J)		Inches	63	
	31	Tread	Front / Rear	Inches	38 3/16 / 39 1/2	
32	Ground Clearance	Lowest (Mast)	Inches	4 5/8		
		Chassis	Inches	5 1/2		
Battery & Other	34	Brake	Service (Foot)	Regenerative braking & Hydraulic-Foot pedal		
	35		Parking	Mechanical Hand lever		
	36	Battery		V/AH	80V / 205Ah	
	37	Motor	AC Drive Motor	Kw	15	
			Lifting Motor	Kw	13.5	
38	Controller Type			ZAPI AC		

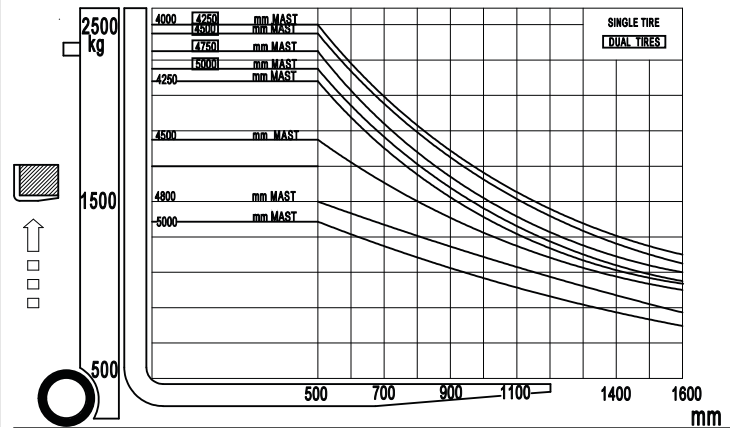
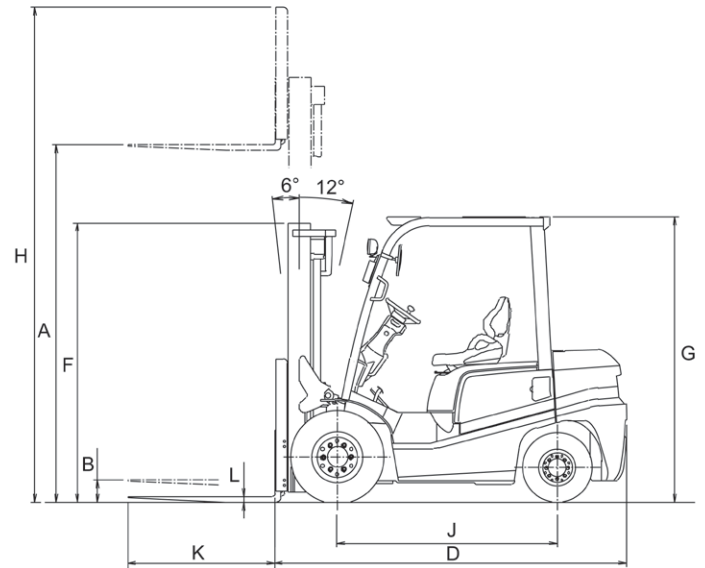
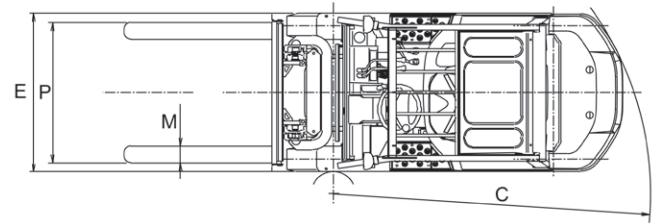

Remarks: Helmar Incorporated reserves the right to make any changes without notice concerning specifications detailed in this brochure.