

Cell Defender Mounting Options (C600 & C800 Models)

12/07/22

Page 1

Thank you for purchasing the Cell Defender™
Cobb River Design™
Mapleton, MN
www.CobbRiverDesign.com
Cobbriverdesign@gmail.com

Parts List:

<u>Qty.</u>	<u>Description</u>
1	Stainless Steel Cell Defender
1	Stainless Steel Large Offset Bracket
1	Stainless Steel Small L-Bracket
1	5/16" carriage bolt
1	5/16" elevator bolt (large round flat head)
1	5/16" hex bolt
2	5/16" lock washers
3	5/16" flat washers
2	5/16" nuts
2	¼" U-bolts
2	¼" lock washers
2	¼" nuts
1	Stainless Steel Stiffener Bracket (C800 model only)

Note: Installation will require either the 5/16" elevator bolt or the 5/16" carriage bolt so only one set of washers and one nut are provided for these 2 bolts.

Shown below is the basic installation into an existing hole in your equipment without the need for either mounting bracket. Install the elevator bolt from the inside. (Using the elevator bolt instead of the carriage bolt will help to maintain a flatter bottom in the beverage holder area.) Add flat washer, lock washer and nut on bottom of bolt.

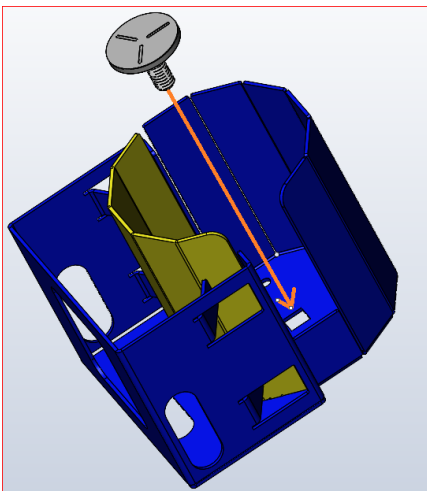

Figure 1

Installation using the offset bracket (ex: flat monitor rail or round mounting bar):

Install the 5/16" elevator bolt as shown in Figure 1.

Note: offset bracket can be mounted with offset either up or down (up shown).

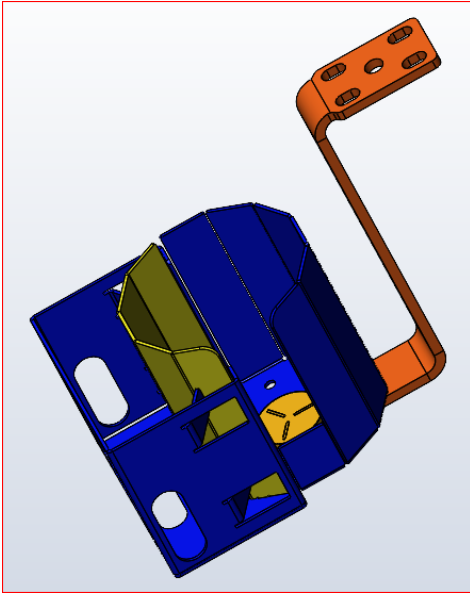

Figure 2

If mounting to a flat rail install the 5/16" bolt from the top and add washers and nut as needed.

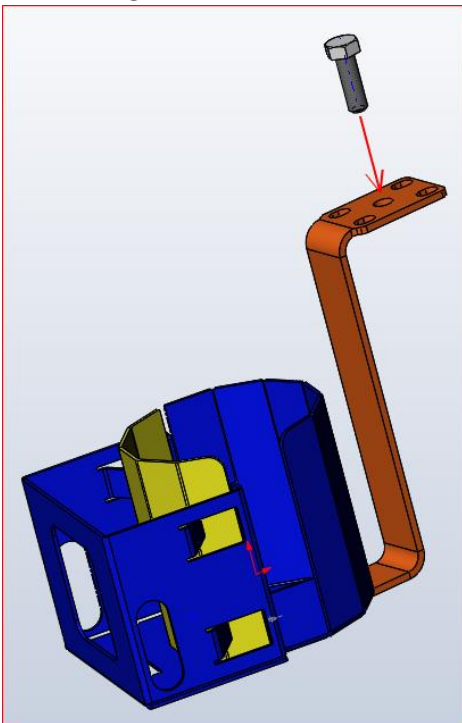

Figure 3

If mounting to a round rail use the 1/4" U-bolts as shown. Add washers and nuts as needed.

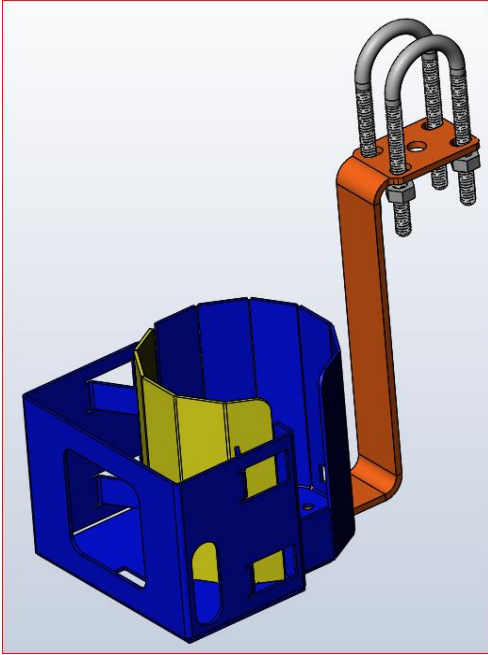

Figure 4

If you are using the small L-bracket - install the 5/16" elevator bolt as shown in Figure 1. Then bolt the bracket to your equipment as needed using the 5/16" hex bolt, washers and nut.

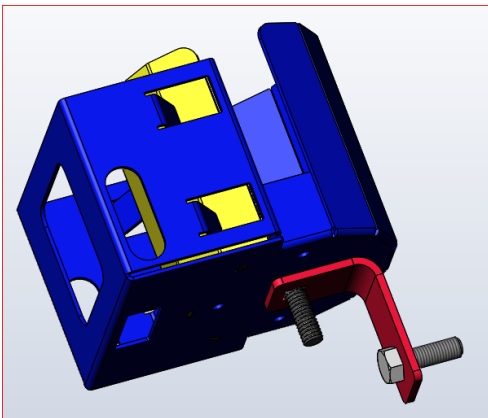

Figure 5

Or the L-bracket can be mounted to the square hole in the back using the 5/16" carriage bolt as shown below:

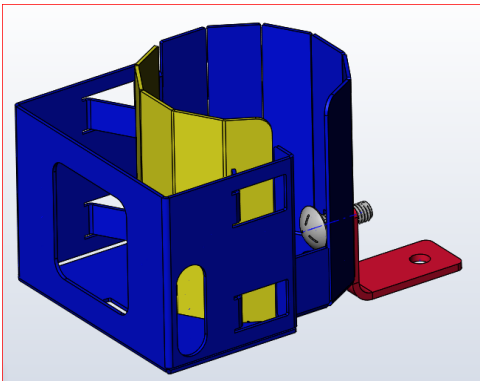

Figure 6

C800 Model Only: If mounting the Cell Defender utilizing the rear mtg. hole install stiffener inside of cup holder as shown below – then insert the carriage bolt from inside as shown in figure 6.

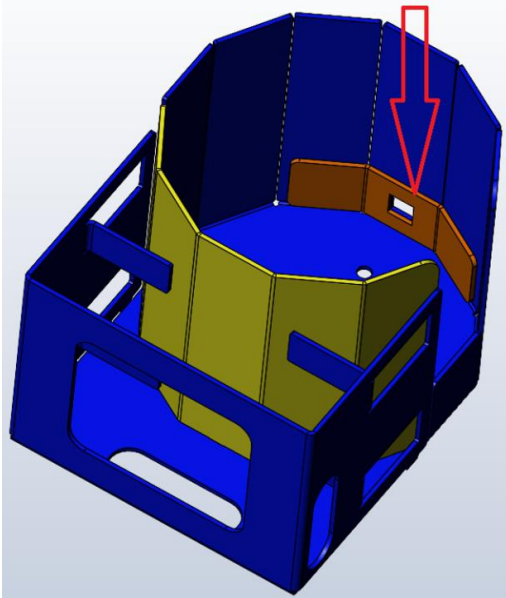

Figure 7

There are many other possible mounting configurations that can be utilized depending on your equipment. Make sure to mount the Cell Defender so it does not interfere with any controls on your equipment. Only use re-closeable liquid containers in the beverage holder.

Note: Cobb River Design is not responsible for any loss, damage or injury that may occur during the use of this product.