



ROBOTICS

IRB 52

A compact painting specialist



Compact

The compact design of the IRB 52 means smaller spray-booth sizes, reduced ventilation needs and system energy savings.

Flexible

With its small size and impressive reach (1.2 or 1.45 meters) the IRB 52 is flexible and versatile, while its high speed and accuracy offer short cycle times and high quality painting.

Versatile mounting options allow the IRB 52 to meet your demands for flexible integration and increased production.

The IRB 52 can be easily integrated with a range of process accessories, such as turntables, shuttle tables and conveyor systems. The robot is light weight and very easy to install, program and maintain.

Integrated

The IRB 52 is designed for painting and is fully pre-pared for integrated paint process equipment. It utilizes the powerful and well proven Integrated Process System (IPS) for high speed process control synchronized with the superior IRC5P motion system.

The IRB 52 is a compact painting robot designed specifically for painting small and medium sized parts in a wide range of industries. It provides you with an affordable, professional and high-quality painting solution.

The IPS system includes color change valves and air-and paint regulation, providing accurate process regulation, offering high quality finish and major paint savings.

The combination of proven technology and well- tested innovations offers reliable production and high uptime. The IRB 52 can significantly improve your productivity.

Designed for painting

The IRC5P is the newest generation paint robot control system specifically designed for the paint shop. Key elements of its user friendly interface are the Exi certified FlexPaint pendant with multi-language support, and the customizable PC software for paint cell supervision, RobView 5.



Specification

Robot version	Payload on wrist (kg)	Reach vertical arm (m)
IRB 52/1.2	7	0.475
IRB 52/1.45	7	0.7
Number of axes	6	
Protection	IP66 (wrist IP54)	
Mounting	Floor, inverted, wall, tilted	
Controller	IRC5P Paint	
Ex-certification	Explosion protected Exi/Exp for installation in hazardous area, Zone 1 (Europe) and Division I, Class I & II	

Performance (according to ISO 9283)

	IRB 52/1.2	IRB 52/1.45
Static repeatability (mm)	0.15	0.15
Path accuracy (mm)	+/- 2	+/- 2

Technical information

Electrical Connections

Supply voltage	200-600 VAC, 3-phase, 50-60 Hz
Power consumption	Stand by <300 W, Production <800 W
Electrical safety	According to international standards

Physical

Robot footprint	484 x 648 mm
Robot controller	1450 x 725 x 710 mm
Robot unit weight	250 kg
Robot controller weight	180 kg
Height IRB 52/1.2	1069 mm
Height IRB 52/1.45	1294 mm

Environment

Ambient temperature	
Robot unit	+5 °C (41 °F) to +40° C (104 °F)
Robot controller	+48 °C (118 °F) max.
Relative humidity	Max. 95 %, non-condensing

Interface IRC5P Paint

Digital inputs/outputs	512/512, expandable
Analog inputs/outputs	16/12, expandable
Fieldbus support	Interbus-S, ProfiBus, CC Link, DeviceNet

Data and dimensions may be changed without notice.

Movement

Axis movement	Working range IRB 52/1.2	Working range IRB 52/1.45	Axis max speed
Axis 1 rotation	+180° to -180°	+180° to -180°	180°/s
Axis 2 arm	+110° to -63°	+120° to -90°	180°/s
Axis 3 arm	+55° to -235°	+55° to -235°	180°/s
Axis 4 arm	+200° to -200°	+200° to -200°	320°/s
Axis 5 bend	+115° to -115°	+115° to -115°	400°/s
Axis 6 rotation	+400° to -400°	+400° to -400°	460°/s

Working range, IRB 52/1.2

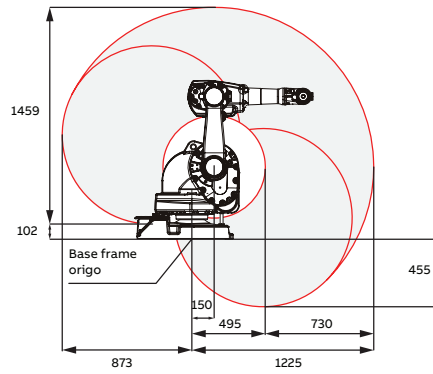

Rotation range, IRB 52/1.2

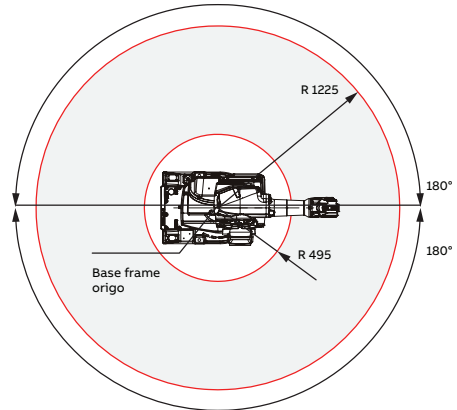

Working range, IRB 52/1.45

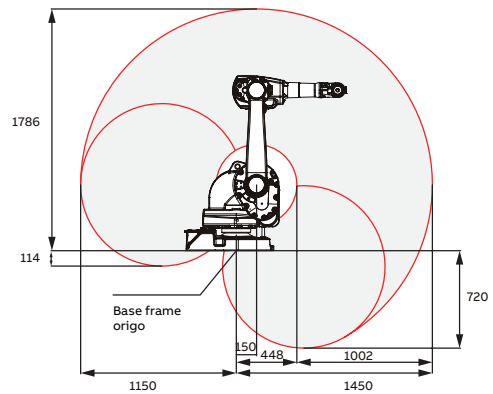

Rotation range, IRB 52/1.45

