



# Fouries Home Inspection

*Know before you Buy*

COMPLETE HOME INSPECTION  
Prepared Exclusively For: First Name Last Name

Built in 1897  
(122 year old home), , TX,



Inspected by Paul Fourie, Lic.#: 22325 on 01/01/2019  
Phone: (972)989-2479, Email: paul@fourieshomeinspection.com



or future reports.

ITEMS IDENTIFIED IN THE REPORT DO NOT OBLIGATE ANY PARTY TO MAKE REPAIRS OR TAKE OTHER ACTIONS, NOR IS THE PURCHASER REQUIRED TO REQUEST THAT THE SELLER TAKE ANY ACTION. When a deficiency is reported, it is the client's responsibility to obtain further evaluations and/or cost estimates from qualified service professionals. Any such follow-up should take place prior to the expiration of any time limitations such as option periods. Evaluations by qualified tradesmen may lead to the discovery of additional deficiencies which may involve additional repair costs. Failure to address deficiencies or comments noted in this report may lead to further damage of the structure or systems and add to the original repair costs. The inspector is not required to provide follow-up services to verify that proper repairs have been made.

Property conditions change with time and use. For example, mechanical devices can fail at any time, plumbing gaskets and seals may crack if the appliance or plumbing fixture is not used often, roof leaks can occur at any time regardless of the apparent condition of the roof, and the performance of the structure and the systems may change due to changes in use or occupancy, effects of weather, etc. These changes or repairs made to the structure after the inspection may render information contained herein obsolete or invalid. This report is provided for the specific benefit of the client named above and is based on observations at the time of the inspection. If you did not hire the inspector yourself, reliance on this report may provide incomplete or outdated information. Repairs, professional opinions or additional inspection reports may affect the meaning of the information in this report. It is recommended that you hire a licensed inspector to perform an inspection to meet your specific needs and to provide you with current information concerning this property.

#### **TEXAS REAL ESTATE CONSUMER NOTICE CONCERNING HAZARDS OR DEFICIENCIES**

Each year, Texans sustain property damage and are injured by accidents in the home. While some accidents may not be avoidable, many other accidents, injuries, and deaths may be avoided through the identification and repair of certain hazardous conditions. Examples of such hazards include:

- malfunctioning, improperly installed or missing ground fault circuit protection (GFCI) devices for electrical receptacles in garages, bathroom, kitchens, and exterior areas;
- malfunctioning arc fault protection (AFCI) devices;
- ordinary glass in locations where modern construction techniques call for safety glass;
- malfunctioning or lack of fire safety features such as, smoke alarms, fire-rated doors in certain locations, and functional emergency escape and rescue openings in bedrooms;
- malfunctioning carbon monoxide alarms;
- excessive spacing between balusters on stairways and porches;
- improperly installed appliances;
- improperly installed or defective safety devices;
- lack of electrical bonding and grounding; and
- lack of bonding on gas piping, including corrugated stainless steel tubing (CSST).

To ensure that consumers are informed of hazards such as these, the Texas Real Estate Commission (TREC) has adopted Standards of Practice requiring licensed inspectors to report these conditions as "Deficient" when performing an inspection for a buyer or seller, if they can be reasonably determined.

These conditions may not have violated building codes or common practices at the time of the construction of the home, or they may have been "grandfathered" because they were present prior to the adoption of codes prohibiting such conditions. While the TREC Standards of Practice do not require inspectors to perform a code compliance inspection, TREC considers the potential for injury or property loss from the hazards addressed in the Standards of Practice to be significant enough to warrant this notice.

Contract forms developed by TREC for use by its real estate licensees also inform the buyer of the right to have the home inspected and can provide an option clause permitting the buyer to terminate the contract within a specified time. Neither the Standards of Practice nor the TREC contract forms requires a seller to remedy conditions revealed by an inspection. The decision to correct a hazard or any deficiency identified in an inspection report is left to the parties to the contract for the sale or purchase of the home.

**INFORMATION INCLUDED UNDER "ADDITIONAL INFORMATION PROVIDED BY INSPECTOR", OR PROVIDED AS AN ATTACHMENT WITH THE STANDARD FORM, IS NOT REQUIRED BY THE COMMISSION AND MAY CONTAIN CONTRACTUAL TERMS BETWEEN THE INSPECTOR AND YOU, AS THE CLIENT. THE COMMISSION DOES NOT REGULATE CONTRACTUAL TERMS BETWEEN PARTIES. IF YOU DO NOT UNDERSTAND THE EFFECT OF ANY CONTRACTUAL TERM CONTAINED IN THIS SECTION OR ANY ATTACHMENTS, CONSULT AN ATTORNEY.**

---

---

**ADDITIONAL INFORMATION PROVIDED BY INSPECTOR**

---

**NOTICE: THIS REPORT IS PAID FOR BY AND PREPARED FOR THE CLIENT NAMED ABOVE EXCLUSIVELY. THIS REPORT IS NOT VALID WITHOUT THE SIGNED INSPECTION AGREEMENT AND IS NOT TRANSFERABLE.**

---

The inspection report provided by Fouries Home Inspection will contain the good faith opinions of the inspector concerning the observable need, if any, on the day of the inspection, for the repair, replacement, or further evaluation by experts of the items inspected. **A home inspection is not an exhausting report of defects.**

Unless, specifically stated, this report will not include and should not be read to indicated opinions as to the environmental conditions such as the presence of mold, radon or lead base paint, the presence of toxic or hazardous waste or substances, presence of termite or wood-destroying organisms, or compliance with codes, ordinances, statutes or restrictions, or the insurability, efficiency, quality, durability, future life, or future performance of any item inspected. This report is good for the day of the inspection only and is not to be used for Real Estate Disclosure Documents, Home Warranties or Insurance Underwriting purposes.

There are many factors which determine the life expectancy of a system or component. It is not possible to determine these factors during a one time visual inspection. Some systems of components may perform beyond their typical life expectancy while others may require repair or replacement sooner.

A Summary Report may be provided at the end of the inspection report document. The summary lists deficiencies discovered at the subject property. The summary is not a replacement for the inspection report.

This report is prepared using a computer and infrequently a word or sentence may be accidentally deleted or altered. Should you encounter such a condition, please contact Fouries Home Inspection to make the necessary correction and provide you with replacement pages. If you do not understand certain comments or recommendations please call Fouries Home Inspection prior to closing on your transaction for clarification.

All items to be inspected must be accessible at the time of the inspection. Locked and or inaccessible components will not be inspected. As stated in the inspection agreement, notices sent prior to the inspection and the current Texas Real Estate Commission Texas Standards of Practice, the inspector is to inspect listed items which are visible and accessible at the time of the inspection. A re-inspection fee will apply for return trips to inspect inaccessible items.

Whenever a defect (deficiency) of any kind is noted in a system or aspect of the house, we recommend that a qualified (licensed) technician inspect and service the entire system. Sometimes noted defects are symptoms of other, sometimes more serious, defects. It is also recommended that the buyer walks through the property the day before closing to assure conditions have not changed since inspection. All items listed in the home inspection report are inspected according to today's [Texas Standards of Practice](#) and the most current local building standards.

This report contains technical information. You are encouraged to read and understand the entire inspection report. If you do not understand or are unclear about any of the information in the report, please call Fouries Home Inspection (972 989 2479) for a verbal consultation and report review.



### INACCESSIBLE OR OBSTRUCTED AREAS

Sub Flooring - Viewed From Accessible Areas	Attic Space is Limited - Viewed from Accessible Areas
Floors Covered	Crawl Space is limited - Viewed From Accessible Areas
Walls/Ceilings Covered or Freshly Painted	Plumbing Areas - Only Visible Plumbing Inspected
Behind/Under Furniture and/or Stored Items	Siding Over Older Existing Siding

- Mold/Mildew investigations are NOT included with this report; it is beyond the scope of this inspection. Any reference of water intrusion is recommended that a professional investigation be obtained.
- If the property has been renovated or remodeled, you should request documentation that should include permits and any warranties or guarantees that might be applicable, latent defects could exist.
- If additions have been made to this property, you should request documentation that should include permits and any warranties or guarantees that might be applicable. Latent defects could exist.

**This report was prepared for a buyer, seller or property owner in accordance with the client's requirements. The report addresses a single system, component or thermal imaging and is not intended as a substitute for a complete standard inspection of the property. Standard inspections performed by a license holder and reported on a Texas Real Estate Commission promulgated report form may contain additional information a buyer should consider in making a decision to purchase.**

#### LEAVE US AN ONLINE REVIEW

At Fouries Home Inspection we strive for excellence in our work and services. We hope you feel confident in referring us to any family, friends or whomever may need our services. Endorsements from our satisfied clients is our highest measure of success. We invite you to **Leave Us An Online Review**.

I=Inspected

NI=Not Inspected

NP=Not Present

D=Deficient

I NI NP D

## I. STRUCTURAL SYSTEMS

### A. Foundations

*Comments:*

**Foundation Type:** Pier & Beam - Crawlspace

**NOTE:** Future performance of the structure cannot be predicted or warranted. This inspection is one of first impressions and the inspector was not provided with any historical information pertaining to the structural integrity of the inspected real property. This is a limited cursory and visual survey of the accessible general conditions and circumstances present at the time of this inspection. Opinions are based on general observations made without the use of specialized tools or procedures. Therefore, the opinions are based on general apparent conditions and not of absolute fact and are only good for the date and time of this inspection. Weather conditions, drainage, leakage and other adverse factors are able to effect structures, and differential movements are likely to occur. The inspectors opinion is based on visual observations of accessible and unobstructed areas of the structure at the time of the inspection. The inspection of the foundation may show it to be providing adequate support for the structure or having movement typical to this region at the time of the inspection. This does not guarantee the future life or failure of the foundation. The inspector is not a structural engineer. This inspection is not an engineering report or evaluation and should not be considered one, either expressed or implied. If any cause of concern is noted on this report, or if you want further evaluation, you should consider an evaluation by a Structural Engineer or your choice. Foundations are inspected according to today's [Texas Standards of Practice](#).

**SUGGESTED FOUNDATION MAINTENANCE & CARE** - Proper drainage and moisture maintenance to all types of foundations due to the expansive nature of the area load bearing soils. Drainage must be directed away from all sides of the foundation with grade slopes. In most cases, floor coverings and/or stored articles prevent recognition of signs of settlement - cracking in all but the most severe cases. It is important to note, this was not a structural engineering survey nor was any specialized testing done of any sub-slab plumbing systems during this limited visual inspection, as these are specialized processes requiring excavation. In the event that structural movement is noted, client is advised to consult with a Structural Engineer who can isolate and identify causes, and determine what corrective steps, if any, should be considered to either correct and/or stop structural movement.

#### PERFORMANCE OPINION:

**Performance Opinion:** Foundation and structural movement and/or settling have occurred. However, the foundation was supporting the structure at the time of the inspection. The buyer is encouraged to consult with a foundation specialist prior to closing if any concerns exist about the current or future foundation performance. The observations made to support this opinion are listed but not limited to the following:

Areas of the interior floors did not appear to be level and were an indication of movement, settlement or other defects in need of repair. The cause of un-level or sloping floors should be determined and repaired as needed.

I=Inspected

NI=Not Inspected

NP=Not Present

D=Deficient

I	NI	NP	D
---	----	----	---



Cracks in interior walls were an indication of movement, settlement or other defects (See Interior Walls).

**Pier & Beam Crawl Space:**

Crawl Space Viewed From: Entered Crawl Space

Sub-floor damage was observed in the crawl space. The cause of the sub-floor damage should be determined and the damaged sub-floor materials should be repaired as needed.



Deteriorated pier and beam conditions were observed. Deterioration of pier and beam supports should be repaired to prevent adverse effects to the foundation and structure. Deteriorated pier and beam components should be repaired or replaced by a certified, licensed foundation specialist.

I=Inspected

NI=Not Inspected

NP=Not Present

D=Deficient

I	NI	NP	D
---	----	----	---



Leaning piers were observed in the crawl space. Leaning piers may not provide adequate support for the structure. The inspector recommends that the foundation be further evaluated and repaired as needed by a certified, licensed foundation specialist.



Crawl space vents should be installed within three feet of building corners. The crawl space ventilation was inadequate. Inadequate crawl space ventilation creates conducive conditions for structural damage, wood rot, moisture damage and wood destroying insects.



I=Inspected

NI=Not Inspected

NP=Not Present

D=Deficient

I	NI	NP	D
---	----	----	---



The crawl space was flooded in numerous areas.



No subfloor insulation was installed in the crawl space between the floor joists. Subfloor insulation prevents moisture intrusion and energy loss through the living space flooring.



I=Inspected

NI=Not Inspected

NP=Not Present

D=Deficient

I NI NP D

**B. Grading and Drainage**

*Comments:*

Soil and lot grading and drainage conditions suggest further evaluation by the appropriate professional, i.e.. watering program, drains, landscape specialist, etc. The observations made to support this opinion are listed but not limited to the following:

Inadequate grade slope away from the structure was observed. The recommended grade slope away from the structure is 6 inches per 10 feet. Improper grade slopes away from the structure create conducive conditions for water intrusion and inadequate foundation performance. Improper grade slope away from the structure is in need of repair.

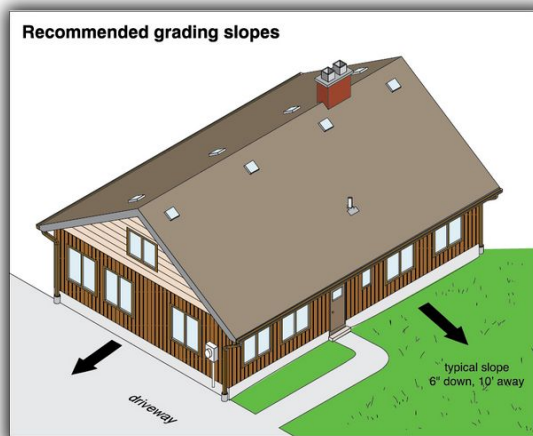

Ponding next to the foundation was observed. Any area where the ground or grade does not slope away from the structure is to be considered an area of improper drainage. Corrective measures may be needed if the water stands within 10-feet of the foundation perimeter beam for more than 24-hours. Grading improvements are needed to direct run off water away from the structure. Recommended slope away from the foundation is 6 inches per 10 feet.

I=Inspected

NI=Not Inspected

NP=Not Present

D=Deficient

I	NI	NP	D
---	----	----	---



The structure has been built below the public street grade. Extra caution should be taken to prevent any possible water intrusion to the structure. Do not build flowerbeds that will cause a damming effect and hold water next to the structure. Positive drainage should always be maintained.

Grading and drainage could be improved with the installation of rain gutters. Properly installed rain gutters can prevent erosion and water ponding and help direct water away from the foundation.



**C. Roof Covering Materials**

*Comments:*

**Type(s) of Roof Covering Materials:** Composite  
**Viewed From:** Roof Level

**NOTE:** Life expectancy of the roofing material is not covered by this home inspection report. If any concerns exist about the roof covering life expectancy or potential for future problems, a roofing specialist should be consulted. This inspection does not determine the insurability of the roof. You are strongly encouraged to have your insurance company and a roof covering specialist physically inspect the roof prior to closing to fully evaluate the condition and insurability of the roof. Roof covering materials are inspected according to current Texas Real Estate Commission [Texas Standards of Practice](#).



I=Inspected

NI=Not Inspected

NP=Not Present

D=Deficient

I NI NP D

**NOTE:** The inspection of the roof does not preclude the possibility of leakage or water damage. Leakage or water damage can occur at any time and may depend on rain intensity, wind velocity and direction and other environmental factors. The entire underside of the roof sheathing is not visible or accessible and can not be inspected for indications of leaks.

**NOTE:** When **D** (D= Deficiency) is marked. It is recommended that all of the roofing covering materials and components be fully evaluated by a certified, licensed roofing specialist, prior to closing.

The roof covering materials were performing as intended at the time of the inspection. The roof covering materials were inspected according to today's Texas Standards of Practice. Roof coverings should be closely monitored over time for wear and weather damage. **If the buyer has any remaining concerns about the roof covering materials, the inspector recommends that a roof covering specialist be consulted.**



Inadequate clearance between exterior siding and roof covering materials was observed. There should be a space between the siding and roof covering. Space between the roof covering and siding provides proper ventilation and prevents water damage to the siding.

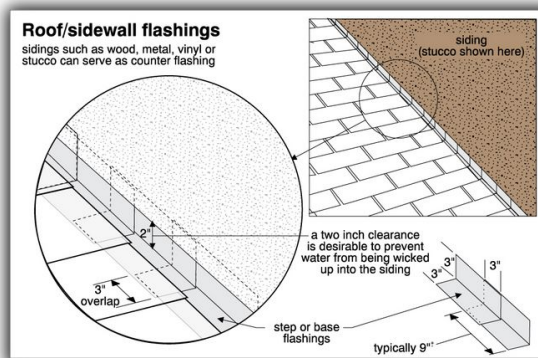

I=Inspected

NI=Not Inspected

NP=Not Present

D=Deficient

I	NI	NP	D
---	----	----	---



Exposed or lifting fasteners or nail heads were observed at the roof coverings. Exposed or lifting fasteners or nail heads may allow water penetration and were in need of repair.



Leave, sticks, branches and other debris were observed on the roof covering and may contribute to roof covering material damage and water penetration. The roof covering surfaces should be free of leaves, sticks, branches and debris.



Current construction standards require a kick out flashing at the roof coverings and wall intersections. Kick out flashings prevent water leaks, damage and discoloration to walls.



I=Inspected

NI=Not Inspected

NP=Not Present

D=Deficient

I NI NP D

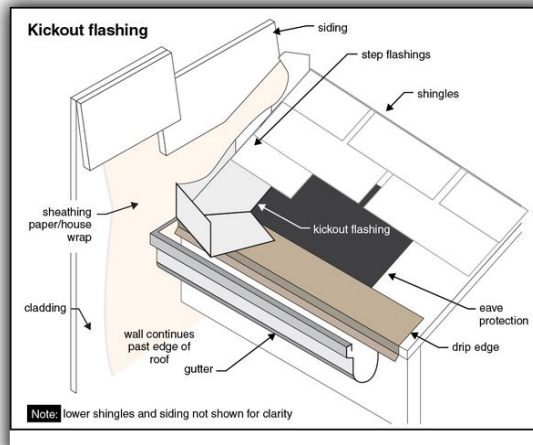

**NOTE:** The roof covering materials should be professionally inspected annually and after storms as part of a routine maintenance plan.

**D. Roof Structures and Attics**

*Comments:*

**Attic Space Viewed From:** Entered the Attic

**Average Depth of Insulation:** 0-3 Inches

**Insulation Type:** Loose Fill Insulation, Batt Insulation

**Description of Roof Structure:** Rafter Assembly

Ridge vents were installed without the benefit of passive soffit/eave vents. The lack of, inadequate or blocked soffit/eave vents is considered inadequate attic ventilation. Inadequate attic ventilation creates conducive conditions for deterioration of structural components, deterioration of roof covering materials, moisture damage, wood destroying insects, duct work damage and other defects.



Insulation voids were observed in the attic space. Insulation voids may allow greater than normal loss of conditioned air and should be repaired.



I=Inspected

NI=Not Inspected

NP=Not Present

D=Deficient

I	NI	NP	D
---	----	----	---

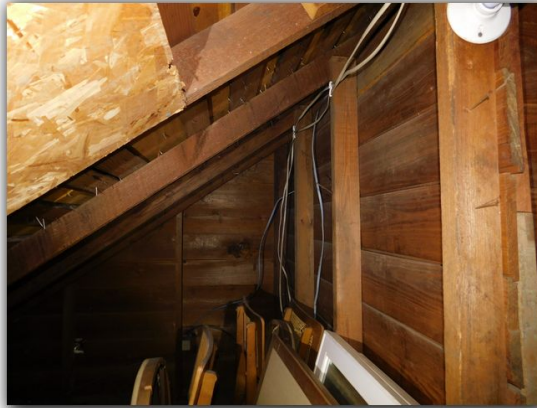

Loose and or damaged insulation was observed in the attic space. Loose or damaged insulation may allow greater than normal loss of conditioned air and should be repaired.



The attic insulation depth or thickness was inadequate. The recommended depth of attic floor insulation is 13+ inches to achieve an R38 rating. Inadequate attic insulation depth or thickness may allow greater than normal loss of conditioned air.

I=Inspected

NI=Not Inspected

NP=Not Present

D=Deficient

I NI NP D

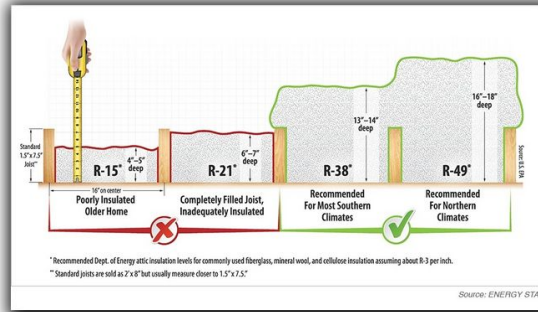

Fascia, soffit, eaves and or trim materials were observed to be damaged. Damaged fascia, soffits, eaves and trim materials should be repaired as needed to prevent further damage, wildlife penetration and moisture penetration.



**E. Walls (Interior and Exterior)**

*Comments:*

**Exterior Walls:**

**Siding Materials:** Wood, Cement Board, Wood Byproducts

Peeling, damaged or deteriorating paint, stain and/or sealant was observed at the exterior wall cladding. Peeling, damaged and deteriorating paint or sealant should be repaired to prevent moisture penetration and deterioration of materials.



I=Inspected

NI=Not Inspected

NP=Not Present

D=Deficient

I	NI	NP	D
---	----	----	---



Peeling, damaged or deteriorating paint, stain and/or sealant was observed at the exterior trim. Peeling, damaged and deteriorating paint or sealant should be repaired to prevent moisture penetration and deterioration of materials.



The exterior wood veneer siding was observed to have some deterioration and/or damage. Damaged and deteriorated exterior wooden siding should be repaired to prevent wall damage, moisture penetration and wood destroying insects.



I=Inspected

NI=Not Inspected

NP=Not Present

D=Deficient

I NI NP D



The exterior wood trim was observed to have some deterioration and/or damage. Damaged and deteriorated exterior wood trim should be repaired to prevent wall damage, moisture penetration and wood destroying insects.

The exterior wood window casing and trim materials were observed to have some deterioration and/or damage. Damaged and deteriorated exterior wood window casing and trim should be repaired to prevent wall damage, moisture penetration and wood destroying insects.



**Interior Walls:**



I=Inspected

NI=Not Inspected

NP=Not Present

D=Deficient

I	NI	NP	D
---	----	----	---

Repairs or improvements are needed at the interior walls. The observations made to support this opinion are listed but not limited to the following:

**NOTE:** The home was occupied and or staged. Household goods and or furnishings limit the visible areas of walls and may conceal damage or defects that would otherwise be observed.

Damages to interior walls were observed to be in need of repair.

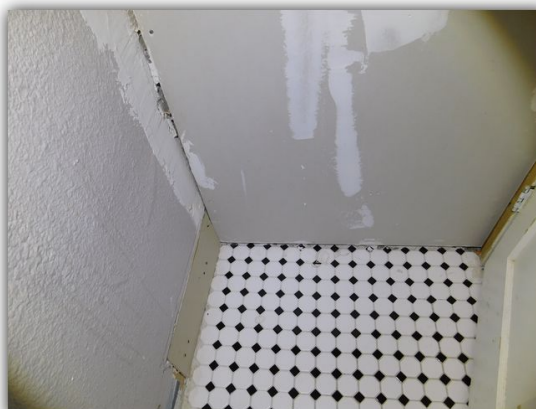
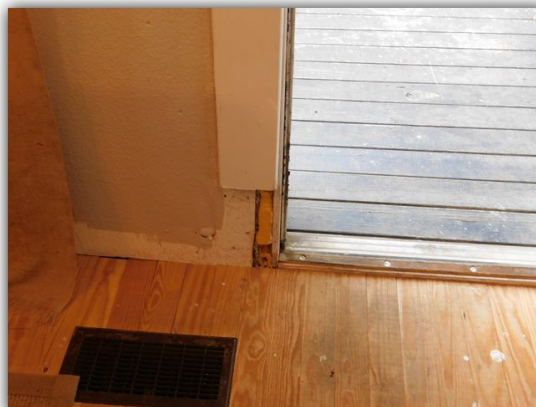

Multiple interior wall cracks were observed and were an indication of structural settling,



I=Inspected

NI=Not Inspected

NP=Not Present

D=Deficient

I NI NP D

movement or other defects. The cause of any interior drywall, texture and paint wall cracks should be determined and repaired as needed and monitored over time for additional movement. Further evaluation of the foundation and structure by a certified, licensed foundation and structural specialist is recommended.

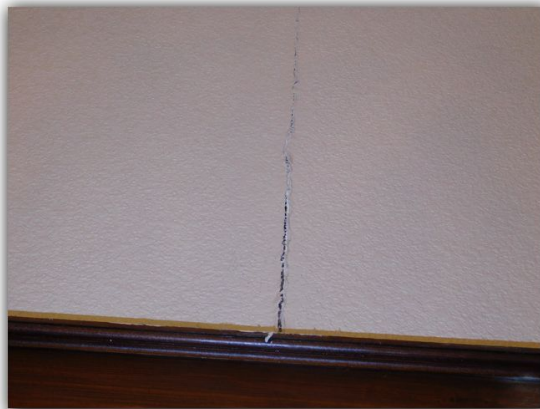
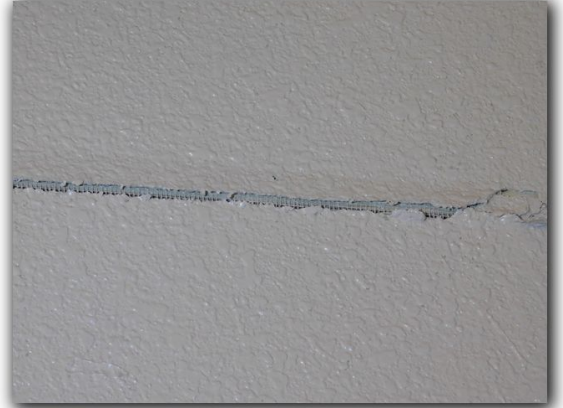
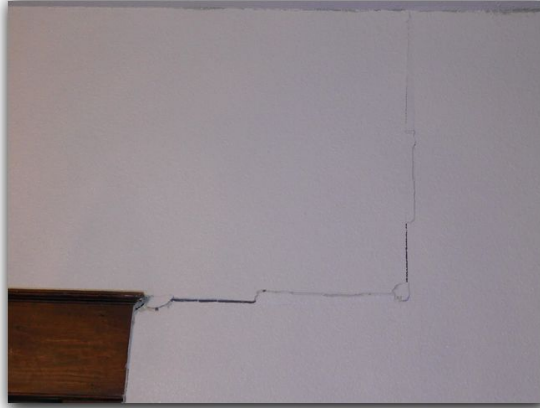

Interior drywall corner tape was observed to be pulling and twisting where walls and or ceilings intersect. This condition is related to adverse foundation or structural performance and should be further evaluated by a foundation or structural specialist and repaired as necessary.

I=Inspected

NI=Not Inspected

NP=Not Present

D=Deficient

I	NI	NP	D
---	----	----	---



**F. Ceilings and Floors**

*Comments:*

**Ceilings:**

Cosmetic damages to ceiling should be repaired.



The ceiling drywall corner tape was observed to be pulling and twisting where walls and ceilings intersect. This condition is related to adverse foundation or structural performance and should be further evaluated by a certified, licensed foundation or structural specialist and repaired as needed.

I=Inspected

NI=Not Inspected

NP=Not Present

D=Deficient

I	NI	NP	D
---	----	----	---



**Floors:**

**NOTE:** The home was occupied and or staged. Household goods and or furnishings limit the visible areas of the floor coverings and may conceal damage or defects that would otherwise be observed.

Sub-floor squeaks were heard in the pier and beam flooring. Subfloor squeaks may indicate that the nails have pulled out and are loose or that other subfloor damage has occurred. Squeaking subfloor materials could also be an indication of movement and or settlement. The buyer should have the subfloor evaluated and secured when the floor covering is replaced if not before.

Areas of the interior floors did not appear to be level and were an indication of movement, settlement or other defects. The cause of un-level floors should be further evaluated by a structural specialist and repaired as needed.

The floor covering was noticeably worn or damaged and was in need of cleaning, repair or replacement.

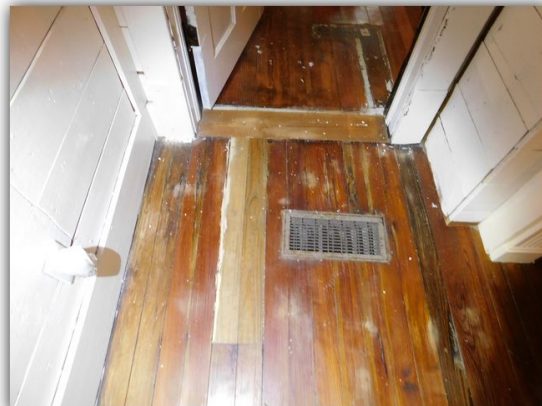



I=Inspected

NI=Not Inspected

NP=Not Present

D=Deficient

I NI NP D



**G. Doors (Interior and Exterior)**

*Comments:*

**Interior Doors:**

All interior doors should have door stops installed to prevent damage to adjacent interior wall coverings.

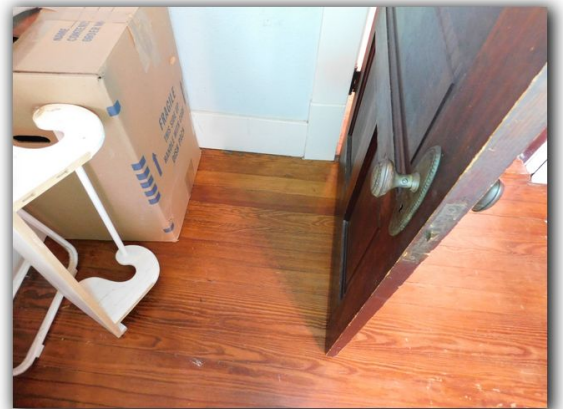
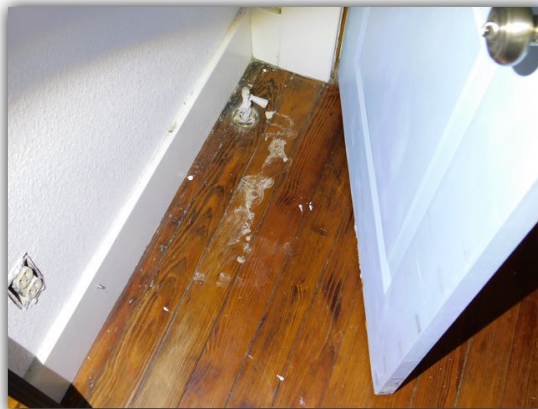
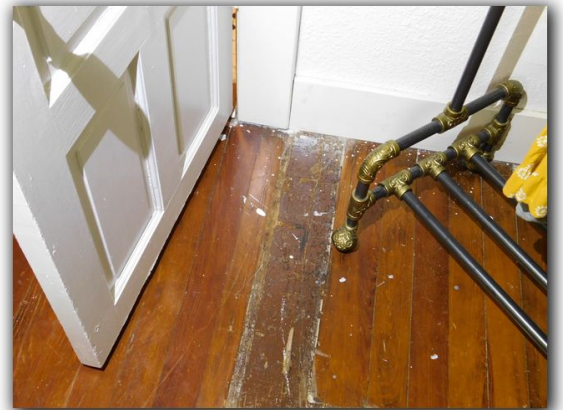

I=Inspected

NI=Not Inspected

NP=Not Present

D=Deficient

I	NI	NP	D
---	----	----	---

Safety glass was not installed in doors in required locations. Lack of door safety glass in required locations is a SAFETY HAZARD.



Interior doors which do not latch as intended should be repaired.

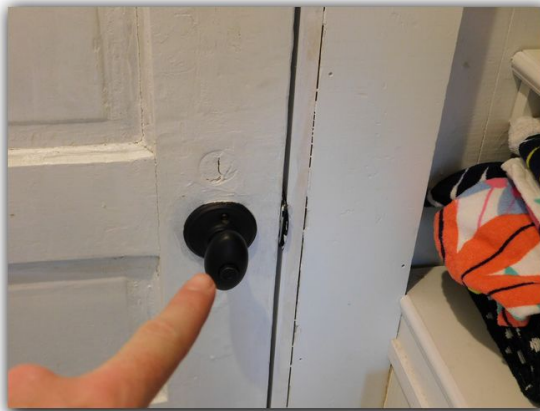

There were missing doors. Missing doors should be replaced .



Interior doors were observed to rub, stick or hit the door frames. Interior doors, that stick or hit the door frame may be an indication of movement, settlement or other defects. The cause of doors sticking or hitting door frames should be determined and repaired as needed.



I=Inspected

NI=Not Inspected

NP=Not Present

D=Deficient

I	NI	NP	D
---	----	----	---

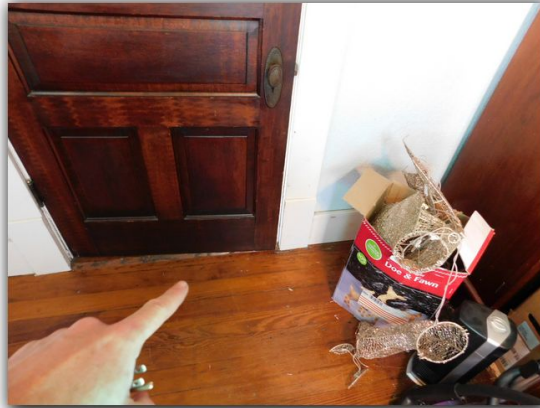

Deficient hardware was observed at interior doors and should be repaired or replaced.



Interior doors which drift closed were observed. Interior doors, which drift, are an indication of movement, settlement or other defects. The cause of door drift should be determined and repaired as needed.

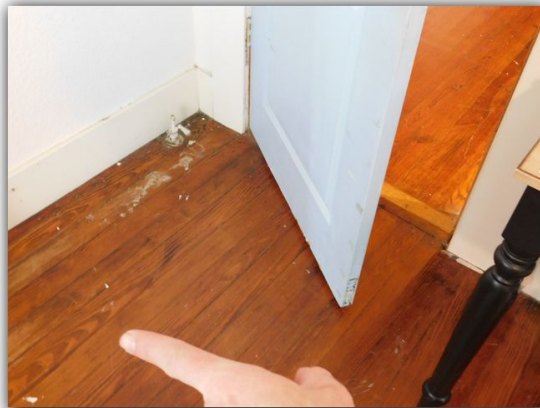

**Exterior Doors:**

Cosmetic damage to exterior doors should be repaired.

I=Inspected

NI=Not Inspected

NP=Not Present

D=Deficient

I	NI	NP	D
---	----	----	---

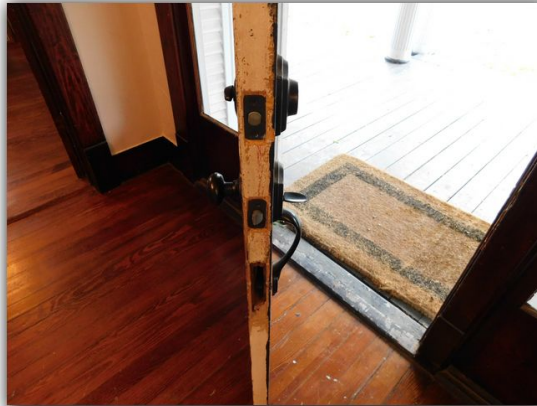

All exterior doors should have door stops installed to prevent damage to adjacent interior wall coverings.

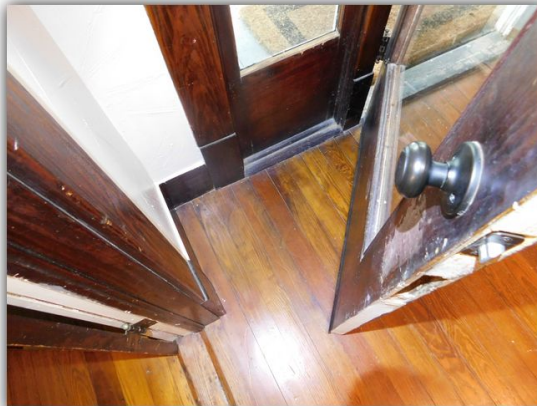

I=Inspected

NI=Not Inspected

NP=Not Present

D=Deficient

I	NI	NP	D
---	----	----	---

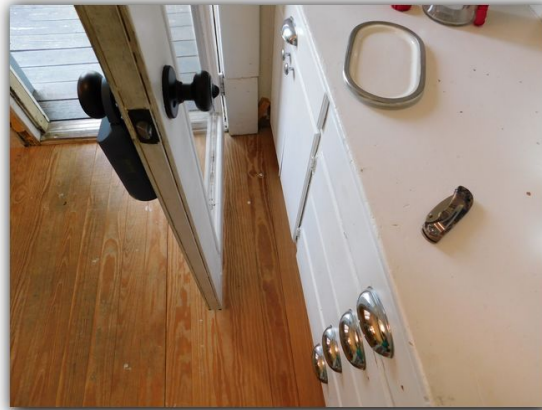

Damaged or missing exterior door weather stripping should be replaced. Missing or damage exterior door weather stripping creates conducive conditions for moisture intrusion and conditioned air loss.

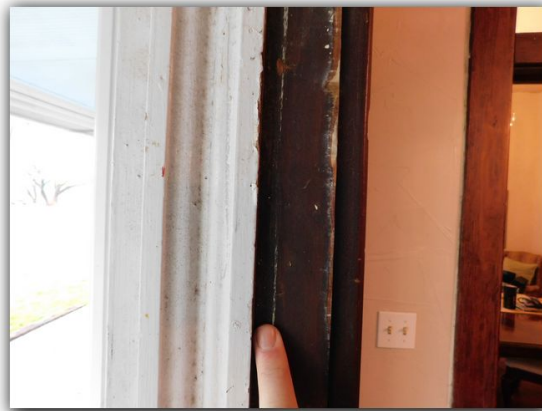

Safety glass was not installed in exterior doors side lights. Lack of exterior door side light safety glass is a SAFETY HAZARD.



Damaged exterior door frames were observed and should be repaired or replaced.



I=Inspected

NI=Not Inspected

NP=Not Present

D=Deficient

I	NI	NP	D
---	----	----	---

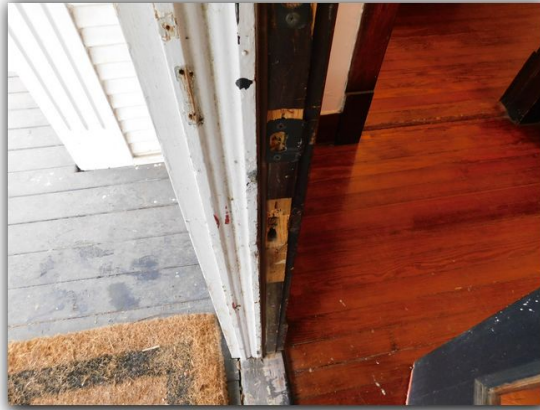

- 
- 
- 
- 

**H. Windows**

*Comments:*

**NOTE:** The home is occupied and or staged. Household goods and or furnishings limit the visible areas and access to windows and may conceal damage or defects that would otherwise be observed.

**NOTE:** The windows are an older component and the future life expectancy cannot be determined. You can continue to use and service this component until replacement is necessary.

The window weather-stripping was observed to be damaged. Damaged or missing weather stripping around windows may allow moisture penetration, conditioned air loss and insect penetration and should be repaired.



One or more of the living area windows have been painted shut. Living area windows that have been painted shut or do not open as intended should be repaired.

I=Inspected

NI=Not Inspected

NP=Not Present

D=Deficient

I NI NP D



One or more of the bedroom windows have been painted shut. At least one window in each bedroom should open fully, with free access to the outdoors. Lack of an operable window in each bedroom is a FIRE SAFETY HAZARD and should be repaired prior to being occupied.



I=Inspected

NI=Not Inspected

NP=Not Present

D=Deficient

I	NI	NP	D
---	----	----	---



Cracked and/or broken window glass was observed. Cracked or broken window glass may allow discoloration of the window glass, allow moisture intrusion, contribute to the loss of conditioned air. Cracked or broken window glass may be a SAFETY HAZARD and should be replaced as needed.

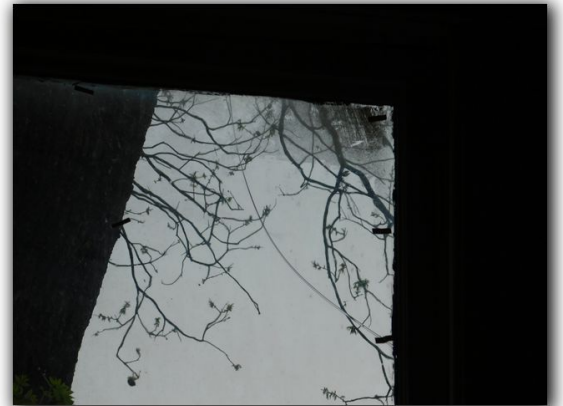

Windows were observed to be missing window screens. Window screens help protect window glass from minor impact damage and prevent insect penetration at the windows. Missing window screens should be replaced.





I=Inspected

NI=Not Inspected

NP=Not Present

D=Deficient

I	NI	NP	D
---	----	----	---

Windows were observed to be acrylic. Acrylic window screens should be replaced.



The window above the tub/shower did not appear to have a safety glass etching or label. Glass less than 5' above the tub/shower should be tempered safety glass. Lack of safety glass in required locations is a SAFETY HAZARD and should be replaced.



**I. Stairways (Interior and Exterior)**

*Comments:*

I=Inspected

NI=Not Inspected

NP=Not Present

D=Deficient

I NI NP D

No handrail was installed for stairs or steps with 4 or more risers. For improved safety, a handrail should be installed at all stairs and steps with 4 or more risers. Lack of properly installed stairway handrails is a SAFETY HAZARD.



The stairway handrail height was observed to be inadequate and was a SAFETY HAZARD. Under current building standards, the stairway handrail height should be 34"-36" and should be corrected prior to closing.

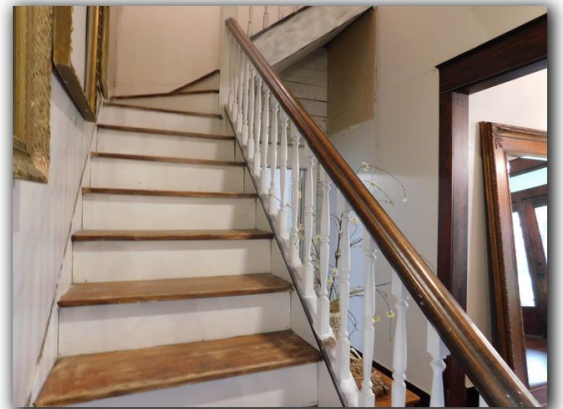
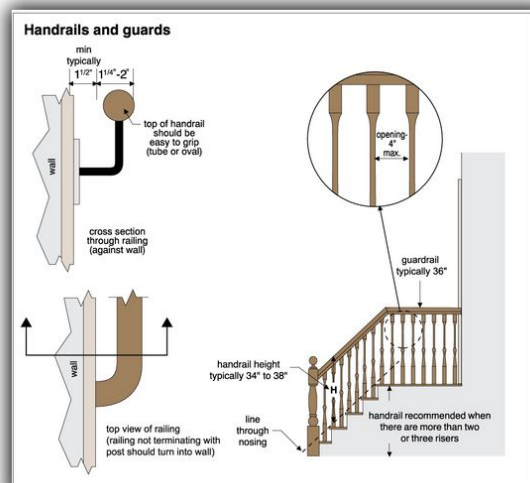

I=Inspected

NI=Not Inspected

NP=Not Present

D=Deficient

I NI NP D

☑ The stairway handrail grip was observed to be inadequate. Stairway handrails should be graspable. Current building standards state that the stairway handrail grip should not be larger than 2". Stairway handrails that are not graspable are a SAFETY HAZARD.

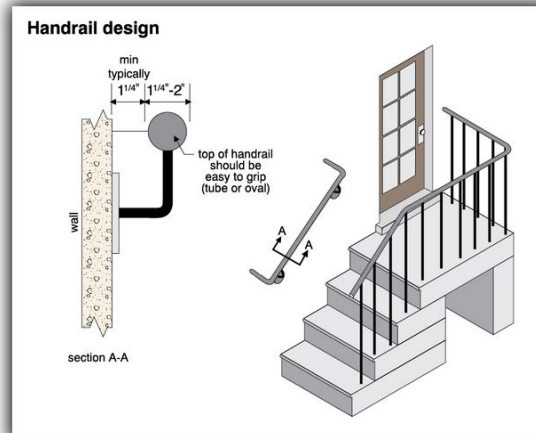

☑ The stairway guard balusters and/or spindles were installed to far apart and were observed to be a SAFETY HAZARD. Under current building standards, stairway guard balusters or spindles should not allow passage of any object greater than 4". This condition should be repaired prior to closing for reasons of safety.

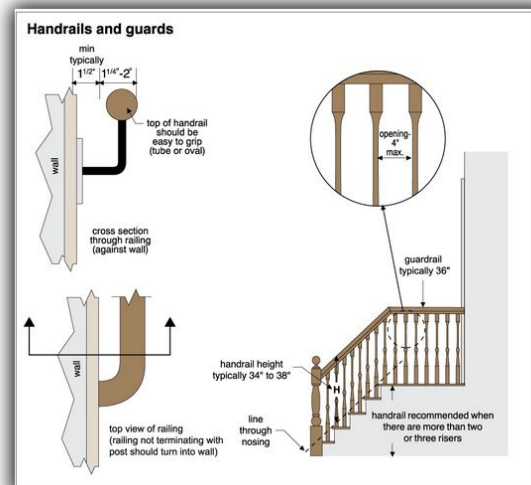

☑ Inadequate stairway headroom was observed. Under current building standards the minimum headroom in all parts of the stairway shall not be less than 6 feet 8 inches measured vertically from the slope of the plane adjoining the tread nosing or from the floor surface of the landing or platform.



I=Inspected

NI=Not Inspected

NP=Not Present

D=Deficient

I NI NP D

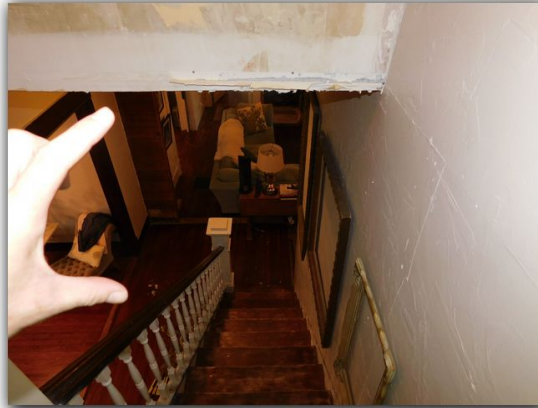

**J. Fireplaces and Chimneys**

*Comments:*

**NOTE:** Gas leaks below the finished grade (underground) or between the wall or behind fireplace hearths or any concealed area cannot be detected and are not inspected.

**NOTE:** The National Fire Protection Association ([nfpa.org](http://nfpa.org)) recommends that fireplaces and chimneys be professionally inspected (Level 2 Inspection) with each change of ownership. The chimney should also be inspected by a qualified chimney sweep certified by the Chimney Safety Institute of America ([csia.org](http://csia.org))

**NOTE:** If the fireplace is equipped with a gas log or gas lighter with the pilot light turned off, the Texas Standards of Practice prevents the inspector from lighting and operating these fixtures. It is recommended that the pilot be lit and the fireplace operation be verified with the current owner prior to closing to ensure proper operation.

Gas fireplace equipment that is not vented to the exterior of the structure is a SAFETY HAZARD. Improperly vented gas heating equipment may allow carbon monoxide or other vapors to accumulate in the living area.



I=Inspected

NI=Not Inspected

NP=Not Present

D=Deficient

I NI NP D

**K. Porches, Balconies, Decks, and Carports**

*Comments:*

Weathered, deteriorated and/or damaged wood deck materials were observed and should be repaired or replaced as needed.



Wooden deck construction materials were observed to be in contact with the ground. Wood to ground contact at decking construction materials creates conducive conditions for wood rot and wood destroying insects.

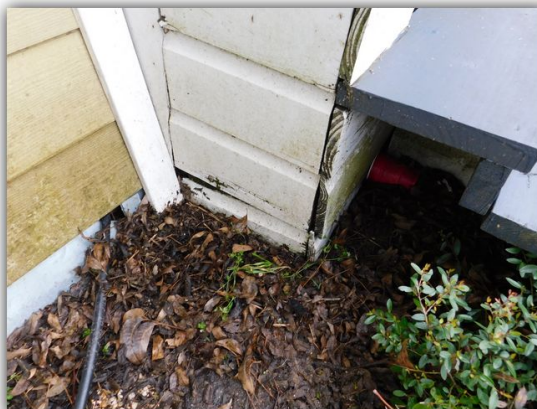

I=Inspected

NI=Not Inspected

NP=Not Present

D=Deficient

I	NI	NP	D
---	----	----	---

- 

**L. Other**

*Comments:*

Fencing is not inspected and is outside the scope of this home inspection. However, there may be fencing deficiencies mentioned in other sections if fencing defects may affect the structure.

**II. ELECTRICAL SYSTEMS**

- 

**A. Service Entrance and Panels**

*Comments:*

**Type of Electrical Conductors:** Copper

**Location:** Exterior Wall

**Rating:** 200 amps



The buyer should have the service panel(s), service entrance and electrical system checked by a certified, licensed electrician. The observations made to support this opinion are listed but not limited to the following:

The electric service panel breaker use was not labeled. Each electric service panel breaker should be adequately labeled as to what appliance or circuit it serves.



I=Inspected

NI=Not Inspected

NP=Not Present

D=Deficient

I NI NP D



The electric service panel electrical conductors have not been properly secured or protected from the sharp edges and or the dead front cover of the cabinet. Electrical conductors that are in contact with the service panel dead front cover and not protected from sharp edges are a SAFETY HAZARD and should be repaired by a qualified electrical specialist.

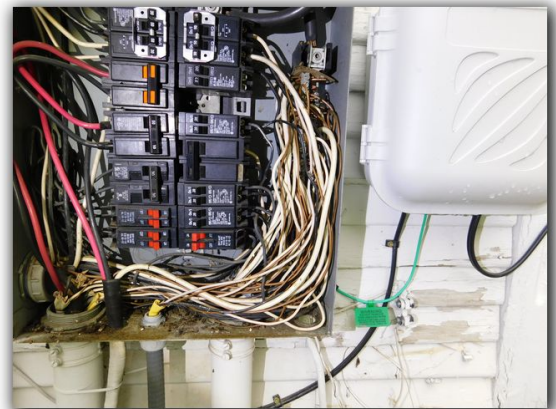

Sub-Panel grounds and neutrals were installed on the same bus bar. The ground wires and the neutral wires were not properly separated in the sub-panel electrical cabinet. The neutral wires should be on their own isolated bus bar and the ground wires should be connected to the sub-panel cabinet. Although the sub-panel may be functional, it does not meet current National Electrical Code standards and should be further evaluated and repaired or replaced by a certified, licensed electrical specialist.

I=Inspected

NI=Not Inspected

NP=Not Present

D=Deficient

I NI NP D

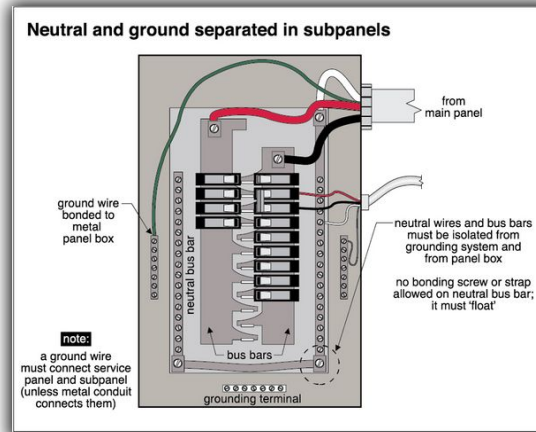

☑ Neutral electrical conductors were observed to be “double tapped” on the neutral bus bar in the electric service panel. Each neutral electrical conductor in the electric service panel should terminate individually unless the terminals are made for more than one conductor. Double tapped neutral electrical conductors should be further evaluated and repaired as needed by a qualified electrical specialist.

☑ Blank spaces (missing breakers) in the electrical service panel were observed to be missing filler covers. Missing or unused breaker slots should be covered with electrical fillers to prevent the unwanted entry of pests, moisture or other items. Lack of a cover filler at missing or unused breaker slots is considered a SAFETY HAZARD and should be repaired as needed by a qualified electrical specialist.



☑ Unused knockouts in the electric service panel were observed to be missing knockout covers (where conductors may pass through electrical cabinet walls). Missing knockout covers or unused conductor openings should be covered with electrical knockout covers to prevent the unwanted entry of pests, moisture or other items. Lack of an electrical knockout cover at unused conductor openings is considered a SAFETY HAZARD and should be repaired as needed by a qualified electrical specialist.

I=Inspected

NI=Not Inspected

NP=Not Present

D=Deficient

I NI NP D

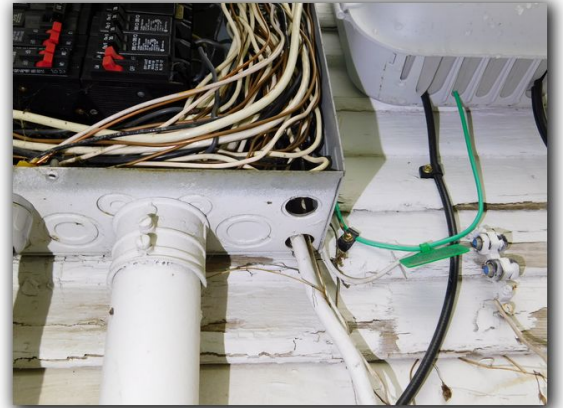
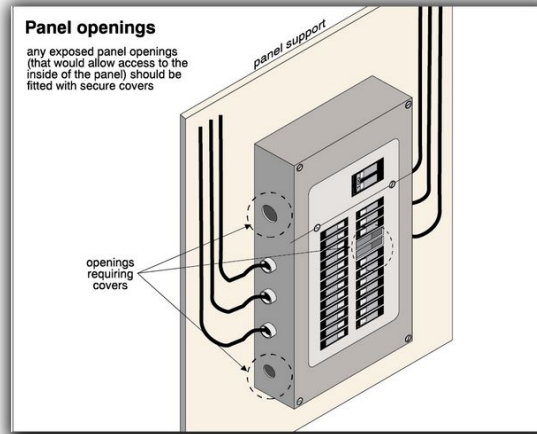

☑ Double tapped breakers / fuses were observed to be a SAFETY HAZARD in the electric service panel. Each breaker should provide electric service to only one circuit. The inspector recommends that the electric service panel be further evaluated and repaired or replaced as needed by a certified, licensed electrician.

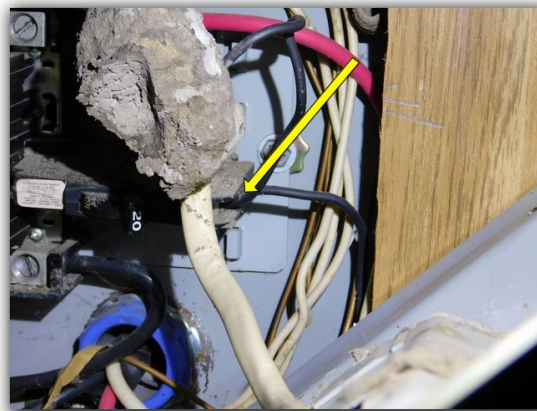
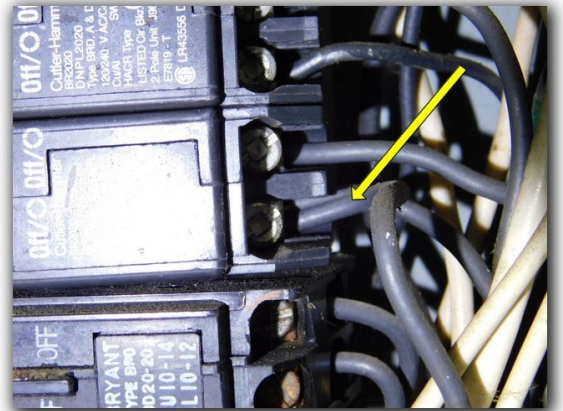
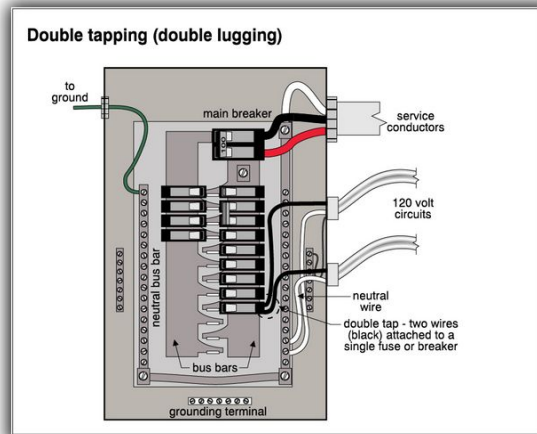

☑ The overhead service drop electrical conductors had inadequate clearance from tree branches. This condition may result in abrasion and damage to the electrical conductors. The inspector



I=Inspected

NI=Not Inspected

NP=Not Present

D=Deficient

I	NI	NP	D
---	----	----	---

recommends correction by a qualified contractor. Work around electric service conductors should be performed by a qualified contractor only. Injury or death may result from attempts at correction by those without proper qualifications.



**Deficient Arc-Fault Protection (AFCI)** - The electrical system components did not appear to meet current arc-fault circuit-interrupter (AFCI) standards. ***This may be an "as-built" condition, but according to today's local building standards, lack of AFCI protection is considered a deficiency.*** For more information, refer to Texas Real Estate Consumer Notice Concerning Recognized Hazards, form OP-1.

Convenience outlet circuits that are not protected by an Arc Fault Circuit Interrupter (AFCI) are deficient. AFCIs are electrical breakers specially designed to protect against fires caused by arcing faults in the home's wiring created by damaged, improperly installed, deteriorated, or worn electrical plugs, cords, and/or branch circuit conductors. AFCIs are required on all convenience outlet circuits in newly constructed homes since 2008 and on bedroom circuits since 2002. Dual function breakers that provide both AFCI and GFCI protection are now available and became a National Electric Code (NEC) building standard in 2014.

Older homes with aging and deteriorating wiring systems can especially benefit from the added protection of AFCIs. Although no requirement exists to do so, it is recommended that the client consider having a qualified electrician evaluate and upgrade branch circuits to include AFCI protection for enhanced safety.

It is recommended the client test these AFCI devices once per year by pressing the Test Button on the device, ensuring the breaker does trip, then resetting the breaker by moving it to the Off position then back to the On position.

It is not uncommon for AFCIs to be warm or even hot. Because of reports of overheating, many installers consider it a "best practice" to install no more than four AFCIs in a row without a space or other device to allow for cooling.

I=Inspected

NI=Not Inspected

NP=Not Present

D=Deficient

I NI NP D

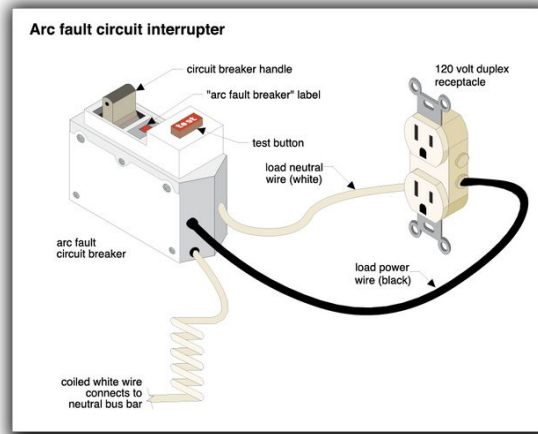

- 
- 
- 
- 

**B. Branch Circuits, Connected Devices, and Fixtures**

*Comments:*

**Type(s) of Branch Circuit Conductors:** Copper

**NOTE:** Electrical components concealed behind finished surfaces or under insulation are not inspected. The inspection does not include remote control devices, alarm systems, low voltage wiring, ancillary wiring or intercoms.

**NOTE:** The home was occupied and or staged. Household goods and or furnishings limit the visible areas and access to branch circuits and connected devices and may conceal damage or defects that would otherwise be observed.

The buyer should have the electrical system and connected devices further evaluated by a certified, licensed electrician. The observations made to support this opinion are listed but not limited to the following:

**Electrical Receptacles:**

Electrical receptacles within five feet of the floor should be tamper resistant safety receptacles according to current building standards. This may be an "as-built" condition and was an accepted building practice at the time this home was constructed. Lack of tamper resistant electrical receptacles is no longer an excepted building standard according to current National Electric Code (NEC).

I=Inspected

NI=Not Inspected

NP=Not Present

D=Deficient

I NI NP D

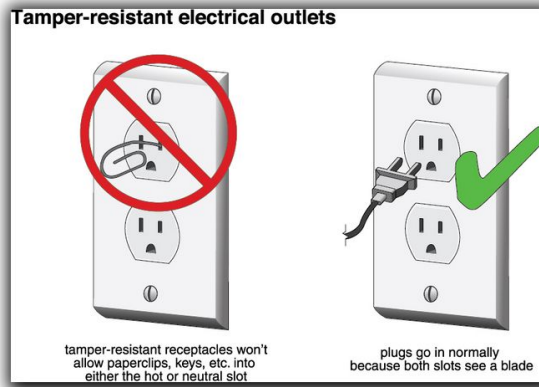

There were one or more areas of the interior walls that lacked an electrical receptacle or the electrical receptacles were improperly spaced.



Open ground connections were observed at electrical receptacles. Open ground electrical receptacles are a SAFETY HAZARD and may cause damage to modern electric appliances. The cause of open ground electrical receptacles should be determined and repaired or replaced as needed by a certified, licensed electrical specialist.





I=Inspected

NI=Not Inspected

NP=Not Present

D=Deficient

I	NI	NP	D
---	----	----	---



Exterior electrical receptacles in wet locations were observed to lack weather tight bubble covers. Lack of weather proof bubble covers at electrical receptacles in wet locations is a SAFETY HAZARD and should be repaired by a certified, licensed electrical specialist.



Painted electrical receptacles were observed. Painted electrical receptacles are considered damaged and should be replaced by a certified, licensed electrical specialist for improved safety and performance.

I=Inspected

NI=Not Inspected

NP=Not Present

D=Deficient

I	NI	NP	D
---	----	----	---



Electrical receptacles, switches and or covers were observed to be loose, damaged, missing or missing screws and were in need of repair. Damaged or missing electrical receptacles or switches should be repaired by a certified, licensed electrical specialist.



**Electrical Conductors:**

Unprotected electrical conductors were observed at the exterior. Unprotected electrical conductors should be relocated or protected by a rigid conduit. Unprotected electrical conductors should be repaired by a certified, licensed electrician.



I=Inspected

NI=Not Inspected

NP=Not Present

D=Deficient

I	NI	NP	D
---	----	----	---



Improperly terminated electrical conductors were observed. All electrical conductor connections should be installed in sealed junction boxes for reasons of safety. Improperly terminated electrical conductors should be repaired by a certified, licensed electrical specialist.

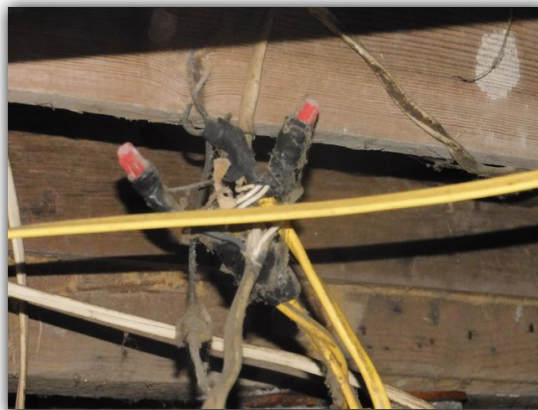
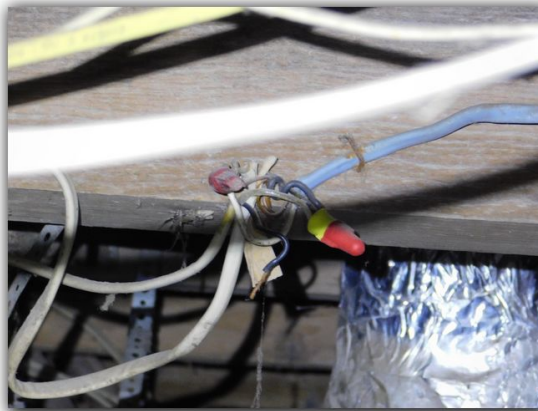



I=Inspected

NI=Not Inspected

NP=Not Present

D=Deficient

I	NI	NP	D
---	----	----	---



Electrical junction / receptacle boxes were observed to be missing covers. All electrical conductor connections should be installed in sealed junction boxes for reasons of safety. Improperly terminated electrical conductors should be repaired by a certified, licensed electrical specialist.

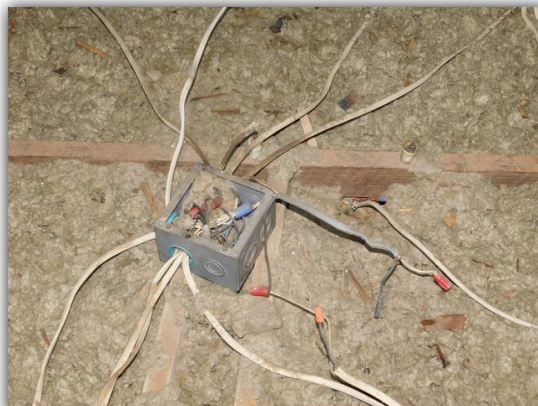
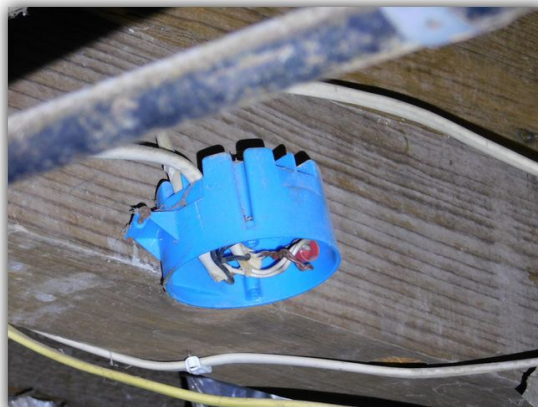

Electrical conductors were in contact with the ground in the crawl space and are a SAFETY HAZARD. Electrical conductors that are improperly supported or are in contact with the ground in the crawl space should be further evaluated and repaired by a certified, licensed electrician.

I=Inspected

NI=Not Inspected

NP=Not Present

D=Deficient

I NI NP D



Knob and tube electrical components were observed. Knob and tube type electrical systems are no longer an accepted electrical standard. Knob and tube electrical systems are considered a SAFETY HAZARD under current building standards. Knob and tube electrical systems should be further evaluated and replaced as needed by a certified, licensed electrical specialist.



**Arc-Fault Protection (AFCI)**

Dual function breakers that provide both AFCI and GFCI protection are now available and became a National Electric Code (NEC) building standard in 2014. Under current electrical



I=Inspected

NI=Not Inspected

NP=Not Present

D=Deficient

I NI NP D

standards, AFCI protection is now required in family rooms, dining rooms, living rooms, parlors, libraries, dens, bedrooms, sun rooms, recreation rooms, closets, hallways, kitchens and laundry rooms. Lack of AFCI protection in required locations is a SAFETY HAZARD.

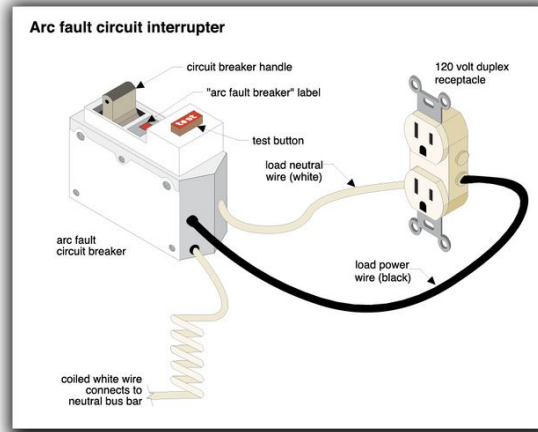

**Ground Fault Circuit Interruption (GFCI) Protection:**

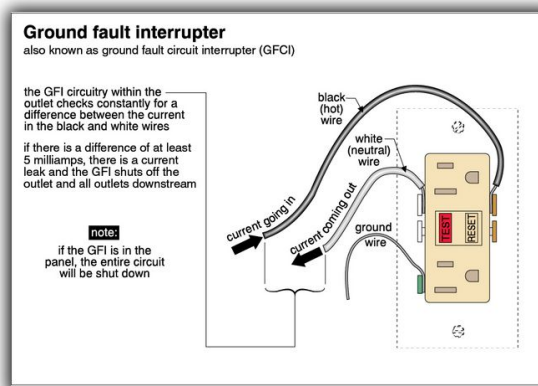

Kitchen counter top electrical receptacles were observed to lack ground fault circuit interrupter (GFCI) device protection. Under current electrical standards, all of the kitchen counter top receptacles should have GFCI protection. Lack of GFCI protection in required locations is a SAFETY HAZARD.



I=Inspected

NI=Not Inspected

NP=Not Present

D=Deficient

I NI NP D



The food waste disposer electrical receptacle was observed to lack ground fault circuit interrupter (GFCI) device protection. According to the 2014 NEC electrical standards, food waste disposer electrical receptacles should be GFCI protected. Lack of GFCI protection in required locations is a SAFETY HAZARD.



Exterior electrical receptacles were observed to lack ground fault circuit interrupter (GFCI) device protection. Under current electrical standards, all of the exterior receptacles should have GFCI protection. Lack of GFCI protection in required locations is a SAFETY HAZARD.

I=Inspected

NI=Not Inspected

NP=Not Present

D=Deficient

I	NI	NP	D
---	----	----	---



**Electrical Fixtures:**

- Inoperative ceiling fans were observed to be in need of repair or replacement.



- Damaged, missing, sagging or warped ceiling fan blades should be replaced.

I=Inspected

NI=Not Inspected

NP=Not Present

D=Deficient

I	NI	NP	D
---	----	----	---



Light fixtures that are inoperative, missing bulbs or have burned out bulbs should be repaired or replaced as needed.



Missing electrical fixtures should be replaced.



I=Inspected

NI=Not Inspected

NP=Not Present

D=Deficient

I	NI	NP	D
---	----	----	---



The doorbell was inoperative and was in need of repair or replacement.



**Smoke and Fire Alarms:**

I=Inspected

NI=Not Inspected

NP=Not Present

D=Deficient

I	NI	NP	D
---	----	----	---

There did not appear to be enough smoke alarms located in required locations (SAFETY HAZARD). Under current building standards, there should be a smoke alarm located in each sleeping room, outside each separate sleeping area in the immediate vicinity of the sleeping rooms, and on each additional story of the dwelling, including basements but excluding crawl spaces and uninhabitable attics (in dwellings with split levels and without an intervening door between the levels, a smoke alarm installed on the upper level and the adjacent lower level shall suffice provided that the lower level is less than one full story below the upper level).



**NOTE:** It is recommended to replace smoke and fire alarm batteries with each change of ownership and once annually for reasons of safety. Replacement of smoke and fire alarms older than 10 years is recommended.

**Carbon Monoxide Detectors:**

**NOTE:** Current building standards state that homes with gas fired appliances and or an attached vehicle storage area (garage) should have installed carbon monoxide detectors outside of all sleeping areas and at each story. Lack of a carbon monoxide detector in required locations is a SAFETY HAZARD. Replacement of carbon monoxide detectors older than 10 years is recommended.

**III. HEATING, VENTILATION AND AIR CONDITIONING SYSTEMS**

**A. Heating Equipment**

*Comments:*

I=Inspected

NI=Not Inspected

NP=Not Present

D=Deficient

I NI NP D

**Type of Heating System:** Central  
**Heating Energy Source:** Gas



**NOTE:** Inspection of the heat exchanger is not possible without disassembly of the unit in most heating equipment systems. Inspection of the heat exchanger is beyond the scope of a home inspection. No guarantee can be made on the heat exchangers life expectancy. Normal service and maintenance of the heating equipment is recommended quarterly by a qualified cooling equipment specialist.

**Heating Equipment Temperatures:**

- Unit 1: Downstairs
  - Within Normal Range    Inadequate - In need of service, repair or replacement
- The heating equipment temperature output reading: 106.8 °F



- Unit 2: Downstairs
  - Within Normal Range    Inadequate - In need of service, repair or replacement
- The heating equipment temperature output reading: 113.1 °F



I=Inspected

NI=Not Inspected

NP=Not Present

D=Deficient

I NI NP D



Dirty or damaged heating equipment air filters may not perform as intended and should be replaced as needed or per manufacturer instructions. Dirty or damaged heating equipment air filters may result in damage to the heating equipment.

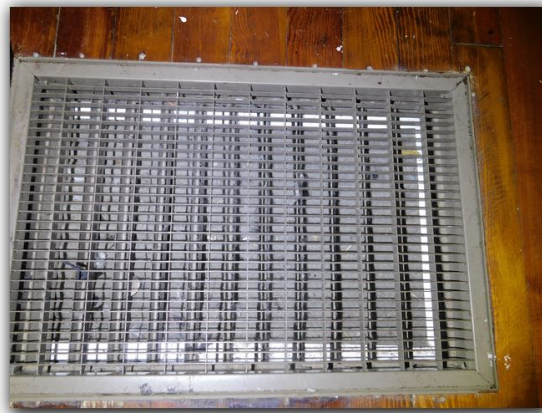

**B. Cooling Equipment**

*Comments:*

**Cooling Equipment Type:** Central - Air Conditioner

I=Inspected

NI=Not Inspected

NP=Not Present

D=Deficient

I NI NP D

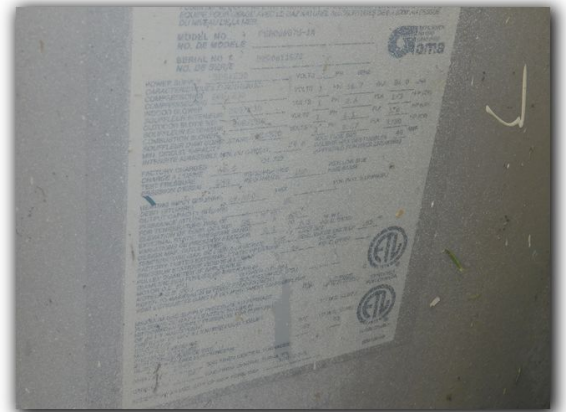
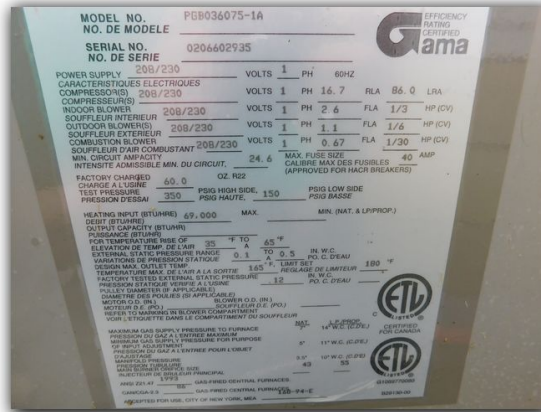

**NOTE:** Pressure tests of the cooling system are outside the scope of a home inspection. No guarantee is made regarding coolant charge or line integrity. The condition of the evaporator coil in the plenum is outside the scope of a home inspection. No guarantee can be made regarding evaporator coils, cooling lines or component life expectancy. Normal service and maintenance of the cooling equipment is recommended quarterly by a qualified cooling equipment specialist.

**Temperature Differentials:**

Cooling equipment temperature differentials were not within range of 14-23 degrees Fahrenheit (Above). The inspector recommends that the cooling equipment be further evaluated and serviced by a licensed specialist when the temperature differential is not within the acceptable range. Temperature differential readings are a fundamental standard for testing the proper operation of the cooling system. The normal acceptable range is considered to be approximately between 14 to 23 degrees F. total difference between the return air and conditioned air. Unusual conditions such as excessive humidity, low outdoor temperature and restricted airflow may indicate abnormal operation even though the equipment is functioning as designed and occasionally may indicate normal operation in spite of an equipment malfunction.

Unit #1: Downstairs

Within Normal Range     Inadequate - In need of service, repair or replacement

Supply Air Temp: 68.7 °F      Return Air Temp: 71.2 °F      Temp. Differential: 2.5 °F



Unit #2: Downstairs



I=Inspected

NI=Not Inspected

NP=Not Present

D=Deficient

I NI NP D

Within Normal Range  Inadequate - In need of service, repair or replacement  
Supply Air Temp: 49.8 °F      Return Air Temp: 67.8 °F      Temp. Differential: 18.0 °F



Dirty or damaged cooling equipment air filters may not perform as intended and should be replaced as needed or per manufacturer instructions. Dirty or damaged cooling equipment air filters may result in damage to the cooling equipment.



The exterior HVAC equipment was installed under the eave without benefit of a roof water diverter flashing or rain gutter which may allow water and debris from the roof covering to damage the equipment.

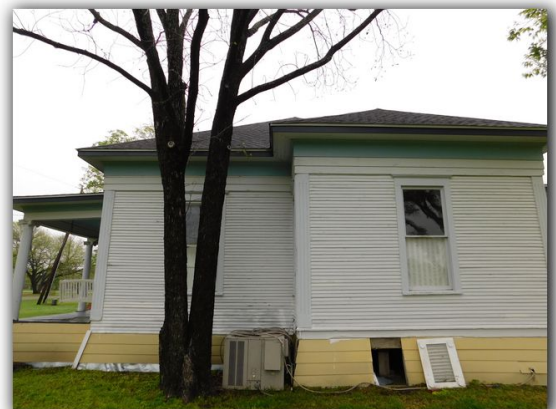



I=Inspected

NI=Not Inspected

NP=Not Present

D=Deficient

I	NI	NP	D
---	----	----	---

- 
- 
- 
- 

**C. Duct Systems, Chases, and Vents**

*Comments:*

The HVAC ductwork insulation was observed to be damaged. Damaged HVAC ductwork insulation may allow conditioned air to escape into unwanted areas. Damaged HVAC ductwork insulation may create conducive conditions for condensation or other moisture intrusion defects.



Ductwork installed in the crawlspace was observed to be in contact with the ground and should be properly supported.



I=Inspected

NI=Not Inspected

NP=Not Present

D=Deficient

I	NI	NP	D
---	----	----	---



The absence of airflow at heating/cooling supply registers was an indication of disconnected or damaged ducts. The cause of inadequate airflow at the heating/cooling supply registers should be determined and repaired as needed.



#### IV. PLUMBING SYSTEM

##### A. Plumbing Supply, Distribution Systems and Fixtures

*Comments:*

**Location of Water Meter:** Water Meter Not Located

**Location of Main Water Valve:** Unknown - Could Not Locate

**Static Water Pressure:** 50-60 psi

I=Inspected

NI=Not Inspected

NP=Not Present

D=Deficient

I	NI	NP	D
---	----	----	---



**NOTE:** Slab construction prevents visual inspection of plumbing located in or below concrete slabs. Plumbing concealed in foundations, below grade, under flatwork, under decks, inside walls, in attics, between ceilings, insulated, in crawl spaces or concealed by other finishes are outside the scope of a home inspection.

**NOTE:** Structural movement, settlement or previous foundation repairs can lead to latent plumbing defects that may not be revealed during a home inspection. If any plumbing defects, structural movement, settlement or previous foundation repairs have been reported, the buyer is encouraged to have the plumbing systems further evaluated and a hydrostatic water pressure test performed by a certified, licensed plumbing specialist.

#### Water Supply System:

Water supply lines in the crawl space were observed to lack adequate insulation. Lack of insulation or inadequate insulation at water supply lines in the crawl space should be corrected to prevent water damage.



#### Exterior Plumbing:

Exterior water supply faucets were missing an anti-siphon device to prevent contaminants from entering the water supply. Lack of anti-siphon devices at exterior water supply faucets is a SAFETY HAZARD. Current building standards require non-removable vacuum breakers on all hose faucets.



I=Inspected

NI=Not Inspected

NP=Not Present

D=Deficient

I NI NP D

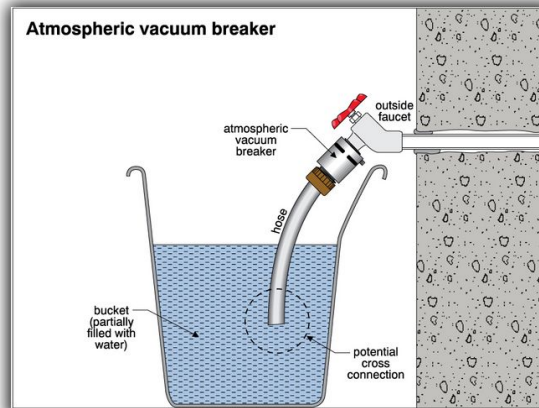

#### Toilets:

The toilets were inspected according to today's Texas Standards of Practice and or local code and was performing as intended at the time of the inspection.

#### Tubs & Showers:

The tub/shower tile grout and sealants were observed to be in need of repair or replacement to prevent water penetration at interior walls. When tub/shower tile grout and sealants are damaged, there may be concealed water damage and or wood destroying insect damage.

I=Inspected

NI=Not Inspected

NP=Not Present

D=Deficient

I	NI	NP	D
---	----	----	---



**Lavatories:**

- The lavatories were inspected according to today's Texas Standards of Practice and or local code and was performing as intended at the time of the inspection.

**Kitchen Sink:**

- Surface damage was observed at the kitchen sink.



- The temperature indicators are missing at the kitchen sink water supply fixture. Missing water supply temperature indicators are considered a SAFETY HAZARD.

I=Inspected

NI=Not Inspected

NP=Not Present

D=Deficient

I	NI	NP	D
---	----	----	---



**Utility Room Plumbing:**

The visible washing machine plumbing connections were inspected according to today's Texas Standards of Practice and or local code and was performing as intended at the time of the inspection.

**Gas Supply System:**

**SPECIFIC LIMITATIONS:** The Inspector is not required to inspect sacrificial anode bonding or for its existence. The Inspector does not perform a pressure test on the gas lines. The Inspector cannot detect gas leaks below the finished grade (underground) or between the wall or behind fireplace hearths or any concealed area. **Propane tanks will not be inspected.** If any further concerns exist about possible gas line failure and or deficiencies, we recommend that the buyer, seller or agent have the gas system further evaluated by a local controlling gas supplier and or a certified, licensed master plumber.



Flexible gas supply lines (connectors) were observed to pass through walls, floors, or ceilings and were a SAFETY HAZARD at the time of the inspection. The gas supply, gas plumbing and all gas appliances should be further evaluated by a certified, licensed gas plumbing specialist.



I=Inspected

NI=Not Inspected

NP=Not Present

D=Deficient

I NI NP D



Older style gas valves require a tool to operate. Under current building standards, gas valves should be operable by hand for reasons of safety.

There were gas fired appliances that did not have a "drip leg" installed. Under current construction standards, drip legs are required at the black iron gas pipe prior to a flexible gas line connection.

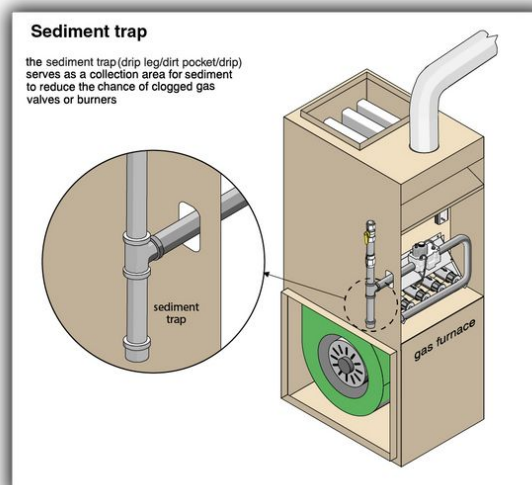

### B. Drains, Wastes, and Vents

*Comments:*

**NOTE:** Buried or concealed sewer and waste drain components are not inspected. Water and waste drain leaks cannot be detected below grade or in concealed locations.

**NOTE:** Structural movement, settlement or previous foundation repairs can lead to latent waste drain defects that may not be revealed during a home inspection. If any waste drain defects, structural movement, settlement or previous foundation repairs have been reported, the buyer is encouraged to have the waste drain plumbing further evaluated by a certified, licensed plumbing specialist.

Temporary accordion type plumbing at the waste drains should be repaired. Temporary

I=Inspected

NI=Not Inspected

NP=Not Present

D=Deficient

I	NI	NP	D
---	----	----	---

plumbing at sink waste drains are a hidden fouling hazard and may cause water damage and create conducive conditions for wood destroying insects.



Waste drains were slow to drain at sinks or tubs. The cause of slow drains should be determined and should be repaired or replaced as needed.



**C. Water Heating Equipment**

*Comments:*

**Energy Source:** Electric

**Capacity:** 50 Gallons

**Location:** Laundry Room

I=Inspected

NI=Not Inspected

NP=Not Present

D=Deficient

I NI NP D

Serial No.	0071649289	
Model No.	XE50T06ST45U1	
Manufacture Date.	18FEB2016	
Cap. U.S. Gals.	50	
Phase	1	1
Volts AC	240	208
Upper Element Watts	4500	3380
Lower Element Watts	4500	3380
Total Watts	4500	3380

Rheem Sales Company, Inc.  
Water Heating Division  
Montgomery, Alabama 36117 USA



**Heated Water Temperature ( 132.4 °F):**



Heated water temperature was observed to be greater than 120 degrees Fahrenheit F and was a SAFETY HAZARD. Adequate and safe heated water temperatures are considered to be between 100 degrees and less than 120 degrees Fahrenheit. The cause of improper heated water temperature should be determined and should be corrected as needed. The water heater thermostats may be turned up too high or there may be other defects in the water heating equipment.

The water heating equipment overflow pan lacks a drain to the exterior of the structure. Current building standards state that all water heaters should be equipped with an overflow pan with a drain which drains to the exterior of the structure if leaks would cause damage.



I=Inspected

NI=Not Inspected

NP=Not Present

D=Deficient

I	NI	NP	D
---	----	----	---

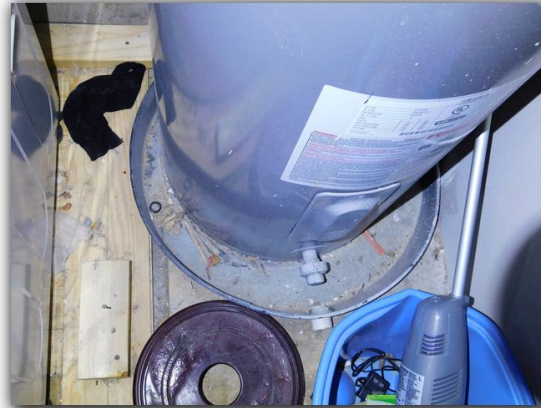

**Water Heating Equipment Temperature and Pressure Relief Valve (TPR Valve):**

- The water heating equipment TPR valve was inspected and verified, but was not tested. It is common for TPR Drain valves to fail under testing and leak water.
- The water heating equipment TPR valve had no drain line plumbing installed. Lack of properly installed TPR drain line plumbing may result in water damage and should be repaired by a qualified plumbing specialist.



**V. APPLIANCES**

- 

**A. Dishwashers**

*Comments:*

- A visible anti-siphon loop or back flow prevention device was not installed at the dishwasher drain line. Some newer dishwashers may have built in anti-siphon devices that are not visible. The buyer is encouraged to consult the owner's manual or contact the manufacturer if an anti-siphon device is not visible. Lack of an anti-siphon device at a dishwasher is a SAFETY HAZARD.

I=Inspected

NI=Not Inspected

NP=Not Present

D=Deficient

I NI NP D

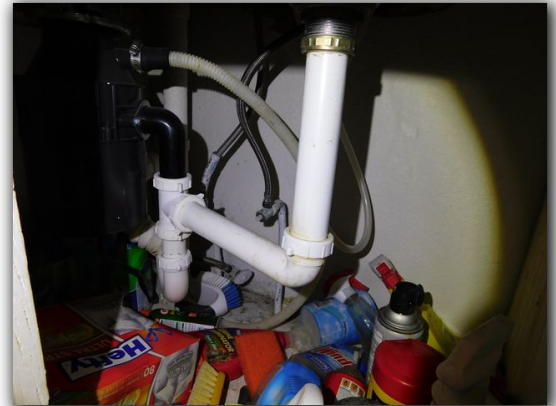
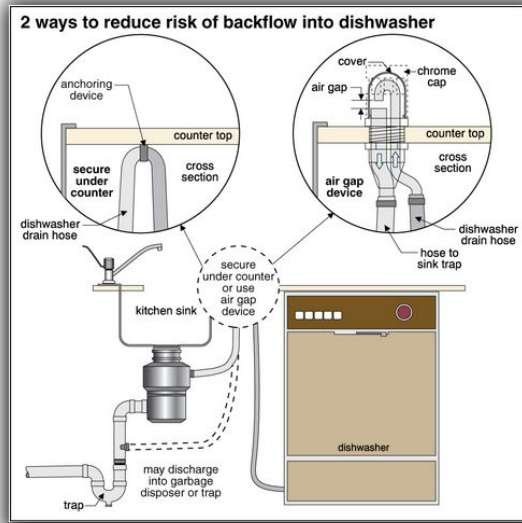

The dishwasher soap dispenser was not functioning properly. Dishwasher soap dispensers that do not perform as intended were an indication that repair or replacement is needed.



**B. Food Waste Disposers**

*Comments:*

The food waste disposer was inspected according to today's Texas Standards of Practice and or local code and was performing as intended at the time of the inspection.

**C. Range Hood and Exhaust Systems**

*Comments:*

The range exhaust vent was inspected according to today's Texas Standards of Practice and or local code and was performing as intended at the time of the inspection.

I=Inspected

NI=Not Inspected

NP=Not Present

D=Deficient

I NI NP D

**D. Ranges, Cooktops, and Ovens**

*Comments:*

**Oven Energy Source:** Gas

**Cooktop Energy Source:** Gas

The range, cooktop and ovens were inspected according to today's Texas Standards of Practice and or local code and were performing as intended at the time of the inspection.



**E. Microwave Ovens**

*Comments:*

The microwave oven was inspected according to today's Texas Standards of Practice and or local code and was performing as intended at the time of the inspection.



**F. Mechanical Exhaust Vents and Bathroom Heaters**

*Comments:*

Current building standards require that all bathrooms have installed a mechanical exhaust vent or an operable window to remove moisture from the air. Lack of an operable window or a mechanical exhaust vent in bathrooms is a deficiency and should be repaired.



I=Inspected

NI=Not Inspected

NP=Not Present

D=Deficient

I	NI	NP	D
---	----	----	---



- 
- 
- 
- 

**G. Garage Door Operators**

*Comments:*

- 
- 
- 
- 

**H. Dryer Exhaust Systems**

*Comments:*

**NOTE:** The National Fire Protection Association (NFPA) recommends that all dryer vent ducts be made from straight metal dryer ducts rather than plastic or flexible metal for improved safety.

The home is occupied. Household goods, washing machines and clothes dryers limit the visible areas and access to plumbing, electrical, walls dryer vents and may conceal damage or defects that would otherwise be observed.

The dryer vent was vented directly into the crawl space and was observed to be a SAFETY HAZARD. Under current building standards, dryer vents should terminate at the exterior of the structure.



- 
- 
- 
- 

**I. Other**

*Comments:*

I=Inspected

NI=Not Inspected

NP=Not Present

D=Deficient

I NI NP D

Refrigerators, ice makers, wine coolers, trash compactors and whole house vacuums are outside the scope of this home inspection and if present, these appliances were not inspected.

## VI. OPTIONAL SYSTEMS

### A. Outbuildings

*Comments:*

**Outbuilding(s):**



The exterior outbuilding wood veneer siding was observed to have some deterioration and/or damage. Damaged and deteriorated outbuilding exterior wooden siding should be repaired to prevent wall damage, moisture penetration and wood destroying insects.

I=Inspected

NI=Not Inspected

NP=Not Present

D=Deficient

I	NI	NP	D
---	----	----	---



Cracked and/or broken outbuilding window glass was observed. Cracked or broken window glass may allow discoloration of the window glass, allow moisture intrusion, contribute to the loss of conditioned air. Cracked or broken window glass may be a SAFETY HAZARD and should be replaced as needed.



Weathered, deteriorated and/or damaged wood outbuilding materials were observed and should be repaired or replaced as needed.



I=Inspected

NI=Not Inspected

NP=Not Present

D=Deficient

I	NI	NP	D
---	----	----	---



**NOTE:** No water supply was available to the outbuilding structure at the time of the inspection. The water supply system, water supply fixtures, wastes, drains and vents were not inspected. The buyer is encouraged to have the water supply system, water supply fixtures, wastes, drains and vents further evaluated by a certified, licensed water supply specialist and or re-inspected (additional fee).



The outbuilding roof covering materials showed indications of leaking. You are encouraged to have your insurance company and a certified, licensed roofing contractor to physically inspect the roof, prior to closing, to fully evaluate the insurability and condition of the roofing materials.

I=Inspected

NI=Not Inspected

NP=Not Present

D=Deficient

I	NI	NP	D
---	----	----	---



Roof penetration waste drain plumbing vents should be painted or wrapped with the appropriate protective material. PVC waste drain plumbing vents are susceptible to premature degradation due to exposure to sunlight.



Water stains or water damage was observed at the outbuilding ceiling drywall, texture and paint. The cause of the water staining or water damage should be determined and repaired as needed.



I=Inspected

NI=Not Inspected

NP=Not Present

D=Deficient

I	NI	NP	D
---	----	----	---



There were outbuilding and or detached garage receptacles that are not connected to a ground fault circuit interrupter (GFCI) device. Under current electrical standards, all of the outbuilding and or detached garage receptacles should have GFCI protection except for one appliance circuit. Lack of GFCI protection in required locations is a SAFETY HAZARD.





## **REPORT SUMMARY**

The "Report Summary" section is intended to be a tool to assist our clients and their representative(s) in preparing a repair request, if and when applicable. THIS IS NOT A LIST OF MANDATORY REPAIRS BUT A LIST OF SUGGESTED REPAIRS OR UPGRADES NEEDED. The Report Summary is intended to follow the flow of the main body of the Property Inspection Report. The order of repair priority is left up to the sole discretion of the client and your Inspector will not be able to assist you specifying order of importance. Further, this summary contains only those items identified as "Deficient". There may be other items listed in the full body of the Property Inspection Report that could be important to you and you may consider adding to your repair request if and when applicable. You should read and understand the entire Home Inspection Report prior to completing any repair request. This report contains technical information, if you do not understand or are unclear about some of the information contained in the body of this report; please call the office to arrange for a verbal consultation with your inspector prior to the expiration of any time limitations such as option periods.

### **Items Needing Further Evaluation**

- Areas of the interior floors did not appear to be level and were an indication of movement, settlement or other defects in need of repair. The cause of un-level or sloping floors should be determined and repaired as needed.
- Leaning piers were observed in the crawl space. Leaning piers may not provide adequate support for the structure. The inspector recommends that the foundation be further evaluated and repaired as needed by a certified, licensed foundation specialist.
- Soil and lot grading and drainage conditions suggest further evaluation by the appropriate professional, i.e.. watering program, drains, landscape specialist,etc.
- Exposed or lifting fasteners or nail heads were observed at the roof coverings. Exposed or lifting fasteners or nail heads may allow water penetration and were in need of repair.
- Multiple interior wall cracks were observed and were an indication of structural settling, movement or other defects. The cause of any interior drywall, texture and paint wall cracks should be determined and repaired as needed and monitored over time for additional movement. Further evaluation of the foundation and structure by a certified, licensed foundation and structural specialist is recommended.
- Interior drywall corner tape was observed to be pulling and twisting where walls and or ceilings intersect. This condition is related to adverse foundation or structural performance and should be further evaluated by a foundation or structural specialist and repaired as necessary.
- The ceiling drywall corner tape was observed to be pulling and twisting where walls and ceilings intersect. This condition is related to adverse foundation or structural performance and should be further evaluated by a certified, licensed foundation or structural specialist and repaired as needed.
- Areas of the interior floors did not appear to be level and were an indication of movement, settlement or other defects. The cause of un-level floors should be further evaluated by a structural specialist and repaired as needed.
- The buyer should have the service panel(s), service entrance and electrical system checked by a certified, licensed electrician.
- Sub-Panel grounds and neutrals were installed on the same bus bar. The ground wires and the neutral wires were not properly separated in the sub-panel electrical cabinet. The neutral wires should be on their own isolated bus bar and the ground wires should be connected to the sub-panel cabinet. Although the sub-panel may be functional, it does not meet current National Electrical Code standards and should be further evaluated and repaired or replaced by a certified, licensed electrical specialist.
- Neutral electrical conductors were observed to be "double tapped" on the neutral bus bar in the electric service panel. Each neutral electrical conductor in the electric service panel should terminate individually unless the terminals are made for more than one conductor. Double tapped neutral electrical conductors should be further evaluated and repaired as needed by a qualified electrical specialist.
- Double tapped breakers / fuses were observed to be a SAFETY HAZARD in the electric service panel. Each breaker should provide electric service to only one circuit. The inspector recommends that the electric service panel be further evaluated and repaired or replaced as needed by a certified, licensed electrician.

- The buyer should have the electrical system and connected devices further evaluated by a certified, licensed electrician.
- Open ground connections were observed at electrical receptacles. Open ground electrical receptacles are a SAFETY HAZARD and may cause damage to modern electric appliances. The cause of open ground electrical receptacles should be determined and repaired or replaced as needed by a certified, licensed electrical specialist.
- Knob and tube electrical components were observed. Knob and tube type electrical systems are no longer an accepted electrical standard. Knob and tube electrical systems are considered a SAFETY HAZARD under current building standards. Knob and tube electrical systems should be further evaluated and replaced as needed by a certified, licensed electrical specialist.
- The water heating equipment overflow pan lacks a drain to the exterior of the structure. Current building standards state that all water heaters should be equipped with an overflow pan with a drain which drains to the exterior of the structure if leaks would cause damage.
- The outbuilding roof covering materials showed indications of leaking. You are encouraged to have your insurance company and a certified, licensed roofing contractor to physically inspect the roof, prior to closing, to fully evaluate the insurability and condition of the roofing materials.
- Water stains or water damage was observed at the outbuilding ceiling drywall, texture and paint. The cause of the water staining or water damage should be determined and repaired as needed.

## Safety Items

- Safety glass was not installed in doors in required locations. Lack of door safety glass in required locations is a SAFETY HAZARD.
- Safety glass was not installed in exterior doors side lights. Lack of exterior door side light safety glass is a SAFETY HAZARD.
- One or more of the bedroom windows have been painted shut. At least one window in each bedroom should open fully, with free access to the outdoors. Lack of an operable window in each bedroom is a FIRE SAFETY HAZARD and should be repaired prior to being occupied.
- Cracked and/or broken window glass was observed. Cracked or broken window glass may allow discoloration of the window glass, allow moisture intrusion, contribute to the loss of conditioned air. Cracked or broken window glass may be a SAFETY HAZARD and should be replaced as needed.
- The window above the tub/shower did not appear to have a safety glass etching or label. Glass less than 5' above the tub/shower should be tempered safety glass. Lack of safety glass in required locations is a SAFETY HAZARD and should be replaced.
- No handrail was installed for stairs or steps with 4 or more risers. For improved safety, a handrail should be installed at all stairs and steps with 4 or more risers. Lack of properly installed stairway handrails is a SAFETY HAZARD.
- The stairway handrail height was observed to be inadequate and was a SAFETY HAZARD. Under current building standards, the stairway handrail height should be 34"-36" and should be corrected prior to closing.
- The stairway handrail grip was observed to be inadequate. Stairway handrails should be graspable. Current building standards state that the stairway handrail grip should not be larger than 2". Stairway handrails that are not graspable are a SAFETY HAZARD.
- The stairway guard balusters and/or spindles were installed too far apart and were observed to be a SAFETY HAZARD. Under current building standards, stairway guard balusters or spindles should not allow passage of any object greater than 4". This condition should be repaired prior to closing for reasons of safety.
- Gas fireplace equipment that is not vented to the exterior of the structure is a SAFETY HAZARD. Improperly vented gas heating equipment may allow carbon monoxide or other vapors to accumulate in the living area.
- The electric service panel electrical conductors have not been properly secured or protected from the sharp edges and or the dead front cover of the cabinet. Electrical conductors that are in contact with the service panel dead front cover and not protected from sharp edges are a SAFETY HAZARD and should be repaired by a qualified electrical specialist.
- Blank spaces (missing breakers) in the electrical service panel were observed to be missing filler covers. Missing or unused breaker slots should be covered with electrical fillers to prevent the unwanted entry of pests, moisture or other items. Lack of a cover filler at missing or unused breaker slots is considered a SAFETY HAZARD and should be repaired

as needed by a qualified electrical specialist.

Unused knockouts in the electric service panel were observed to be missing knockout covers (where conductors may pass through electrical cabinet walls). Missing knockout covers or unused conductor openings should be covered with electrical knockout covers to prevent the unwanted entry of pests, moisture or other items. Lack of an electrical knockout cover at unused conductor openings is considered a SAFETY HAZARD and should be repaired as needed by a qualified electrical specialist.

Electrical receptacles within five feet of the floor should be tamper resistant safety receptacles according to current building standards. This may be an "as-built" condition and was an accepted building practice at the time this home was constructed. Lack of tamper resistant electrical receptacles is no longer an excepted building standard according to current National Electric Code (NEC).

Improperly terminated electrical conductors were observed. All electrical conductor connections should be installed in sealed junction boxes for reasons of safety. Improperly terminated electrical conductors should be repaired by a certified, licensed electrical specialist.

Electrical junction / receptacle boxes were observed to be missing covers. All electrical conductor connections should be installed in sealed junction boxes for reasons of safety. Improperly terminated electrical conductors should be repaired by a certified, licensed electrical specialist.

Electrical conductors were in contact with the ground in the crawl space and are a SAFETY HAZARD. Electrical conductors that are improperly supported or are in contact with the ground in the crawl space should be further evaluated and repaired by a certified, licensed electrician.

Kitchen counter top electrical receptacles were observed to lack ground fault circuit interrupter (GFCI) device protection. Under current electrical standards, all of the kitchen counter top receptacles should have GFCI protection. Lack of GFCI protection in required locations is a SAFETY HAZARD.

The food waste disposer electrical receptacle was observed to lack ground fault circuit interrupter (GFCI) device protection. According to the 2014 NEC electrical standards, food waste disposer electrical receptacles should be GFCI protected. Lack of GFCI protection in required locations is a SAFETY HAZARD.

Exterior electrical receptacles were observed to lack ground fault circuit interrupter (GFCI) device protection. Under current electrical standards, all of the exterior receptacles should have GFCI protection. Lack of GFCI protection in required locations is a SAFETY HAZARD.

There did not appear to be enough smoke alarms located in required locations (SAFETY HAZARD).

Exterior water supply faucets were missing an anti-siphon device to prevent contaminants from entering the water supply. Lack of anti-siphon devices at exterior water supply faucets is a SAFETY HAZARD. Current building standards require non-removable vacuum breakers on all hose faucets.

The temperature indicators are missing at the kitchen sink water supply fixture. Missing water supply temperature indicators are considered a SAFETY HAZARD.

Flexible gas supply lines (connectors) were observed to pass through walls, floors, or ceilings and were a SAFETY HAZARD at the time of the inspection. The gas supply, gas plumbing and all gas appliances should be further evaluated by a certified, licensed gas plumbing specialist.

Older style gas valves require a tool to operate. Under current building standards, gas valves should be operable by hand for reasons of safety.

Heated water temperature was observed to be greater than 120 degrees Fahrenheit F and was a SAFETY HAZARD. Adequate and safe heated water temperatures are considered to be between 100 degrees and less than 120 degrees Fahrenheit. The cause of improper heated water temperature should be determined and should be corrected as needed. The water heater thermostats may be turned up too high or there may be other defects in the water heating equipment.

A visible anti-siphon loop or back flow prevention device was not installed at the dishwasher drain line. Some newer dishwashers may have built in anti-siphon devices that are not visible. The buyer is encouraged to consult the owner's manual or contact the manufacturer if an anti-siphon device is not visible. Lack of an anti-siphon device at a dishwasher is a SAFETY HAZARD.



- The dryer vent was vented directly into the crawl space and was observed to be a SAFETY HAZARD. Under current building standards, dryer vents should terminate at the exterior of the structure.
- Cracked and/or broken outbuilding window glass was observed. Cracked or broken window glass may allow discoloration of the window glass, allow moisture intrusion, contribute to the loss of conditioned air. Cracked or broken window glass may be a SAFETY HAZARD and should be replaced as needed.
- There were outbuilding and or detached garage receptacles that are not connected to a ground fault circuit interrupter (GFCI) device. Under current electrical standards, all of the outbuilding and or detached garage receptacles should have GFCI protection except for one appliance circuit. Lack of GFCI protection in required locations is a SAFETY HAZARD.

## Repair Items

- Performance Opinion:** Foundation and structural movement and/or settling have occurred. However, the foundation was supporting the structure at the time of the inspection. The buyer is encouraged to consult with a foundation specialist prior to closing if any concerns exist about the current or future foundation performance.
- Sub-floor damage was observed in the crawl space. The cause of the sub-floor damage should be determined and the damaged sub-floor materials should be repaired as needed.
- Deteriorated pier and beam conditions were observed. Deterioration of pier and beam supports should be repaired to prevent adverse effects to the foundation and structure. Deteriorated pier and beam components should be repaired or replaced by a certified, licensed foundation specialist.
- Crawl space vents should be installed within three feet of building corners. The crawl space ventilation was inadequate. Inadequate crawl space ventilation creates conducive conditions for structural damage, wood rot, moisture damage and wood destroying insects.
- The crawl space was flooded in numerous areas.
- Ponding next to the foundation was observed. Any area where the ground or grade does not slope away from the structure is to be considered an area of improper drainage. Corrective measures may be needed if the water stands within 10-feet of the foundation perimeter beam for more than 24-hours. Grading improvements are needed to direct run off water away from the structure. Recommended slope away from the foundation is 6 inches per 10 feet.
- Inadequate clearance between exterior siding and roof covering materials was observed. There should be a space between the siding and roof covering. Space between the roof covering and siding provides proper ventilation and prevents water damage to the siding.
- Leave, sticks, branches and other debris were observed on the roof covering and may contribute to roof covering material damage and water penetration. The roof covering surfaces should be free of leaves, sticks, branches and debris.
- Current construction standards require a kick out flashing at the roof coverings and wall intersections.
- Ridge vents were installed without the benefit of passive soffit/eave vents. The lack of, inadequate or blocked soffit/eave vents is considered inadequate attic ventilation. Inadequate attic ventilation creates conducive conditions for deterioration of structural components, deterioration of roof covering materials, moisture damage, wood destroying insects, duct work damage and other defects.
- Insulation voids were observed in the attic space. Insulation voids may allow greater than normal loss of conditioned air and should be repaired.
- Loose and or damaged insulation was observed in the attic space. Loose or damaged insulation may allow greater than normal loss of conditioned air and should be repaired.
- Fascia, soffit, eaves and or trim materials were observed to be damaged. Damaged fascia, soffits, eaves and trim materials should be repaired as needed to prevent further damage, wildlife penetration and moisture penetration.
- Peeling, damaged or deteriorating paint, stain and/or sealant was observed at the exterior wall cladding. Peeling, damaged and deteriorating paint or sealant should be repaired to prevent moisture penetration and deterioration of materials.

- Peeling, damaged or deteriorating paint, stain and/or sealant was observed at the exterior trim. Peeling, damaged and deteriorating paint or sealant should be repaired to prevent moisture penetration and deterioration of materials.
- The exterior wood veneer siding was observed to have some deterioration and/or damage. Damaged and deteriorated exterior wooden siding should be repaired to prevent wall damage, moisture penetration and wood destroying insects.
- The exterior wood trim was observed to have some deterioration and/or damage. Damaged and deteriorated exterior wood trim should be repaired to prevent wall damage, moisture penetration and wood destroying insects.
- The exterior wood window casing and trim materials were observed to have some deterioration and/or damage. Damaged and deteriorated exterior wood window casing and trim should be repaired to prevent wall damage, moisture penetration and wood destroying insects.
- Damages to interior walls were observed to be in need of repair.
- Sub-floor squeaks were heard in the pier and beam flooring. Subfloor squeaks may indicate that the nails have pulled out and are loose or that other subfloor damage has occurred. Squeaking subfloor materials could also be an indication of movement and or settlement. The buyer should have the subfloor evaluated and secured when the floor covering is replaced if not before.
- The floor covering was noticeably worn or damaged and was in need of cleaning, repair or replacement.
- All interior doors should have door stops installed to prevent damage to adjacent interior wall coverings.
- Interior doors which do not latch as intended should be repaired.
- There were missing doors. Missing doors should be replaced .
- Interior doors were observed to rub, stick or hit the door frames. Interior doors, that stick or hit the door frame may be an indication of movement, settlement or other defects. The cause of doors sticking or hitting door frames should be determined and repaired as needed.
- Deficient hardware was observed at interior doors and should be repaired or replaced.
- Interior doors which drift closed were observed. Interior doors, which drift, are an indication of movement, settlement or other defects. The cause of door drift should be determined and repaired as needed.
- Cosmetic damage to exterior doors should be repaired.
- All exterior doors should have door stops installed to prevent damage to adjacent interior wall coverings.
- Damaged or missing exterior door weather stripping should be replaced. Missing or damaged exterior door weather stripping creates conducive conditions for moisture intrusion and conditioned air loss.
- Damaged exterior door frames were observed and should be repaired or replaced.
- The window weather-stripping was observed to be damaged. Damaged or missing weather stripping around windows may allow moisture penetration, conditioned air loss and insect penetration and should be repaired.
- One or more of the living area windows have been painted shut. Living area windows that have been painted shut or do not open as intended should be repaired.
- Windows were observed to be missing window screens. Window screens help protect window glass from minor impact damage and prevent insect penetration at the windows. Missing window screens should be replaced.
- Windows were observed to be acrylic. Acrylic window screens should be replaced.
- Inadequate stairway headroom was observed. Under current building standards the minimum headroom in all parts of the stairway shall not be less than 6 feet 8 inches measured vertically from the slope of the plane adjoining the tread nosing or from the floor surface of the landing or platform.
- Weathered, deteriorated and/or damaged wood deck materials were observed and should be repaired or replaced as needed.
- The overhead service drop electrical conductors had inadequate clearance from tree branches. This condition may result in abrasion and damage to the electrical conductors. The inspector recommends correction by a qualified contractor. Work around electric service conductors should be performed by a qualified contractor only. Injury or death may result from attempts at correction by those without proper qualifications.
- Exterior electrical receptacles in wet locations were observed to lack weather tight bubble covers. Lack of weather proof bubble covers at electrical receptacles in wet locations is a SAFETY HAZARD and should be repaired by a certified, licensed electrical specialist.

- Painted electrical receptacles were observed. Painted electrical receptacles are considered damaged and should be replaced by a certified, licensed electrical specialist for improved safety and performance.
- Electrical receptacles, switches and or covers were observed to be loose, damaged, missing or missing screws and were in need of repair. Damaged or missing electrical receptacles or switches should be repaired by a certified, licensed electrical specialist.
- Unprotected electrical conductors were observed at the exterior. Unprotected electrical conductors should be relocated or protected by a rigid conduit. Unprotected electrical conductors should be repaired by a certified, licensed electrician.
- Inoperative ceiling fans were observed to be in need of repair or replacement.
- Damaged, missing, sagging or warped ceiling fan blades should be replaced.
- Light fixtures that are inoperative, missing bulbs or have burned out bulbs should be repaired or replaced as needed.
- Missing electrical fixtures should be replaced.
- The doorbell was inoperative and was in need of repair or replacement.
- Dirty or damaged heating equipment air filters may not perform as intended and should be replaced as needed or per manufacturer instructions. Dirty or damaged heating equipment air filters may result in damage to the heating equipment.
- Cooling equipment temperature differentials were not within range of 14-23 degrees Fahrenheit (Above). The inspector recommends that the cooling equipment be further evaluated and serviced by a licensed specialist when the temperature differential is not within the acceptable range.
- Dirty or damaged cooling equipment air filters may not perform as intended and should be replaced as needed or per manufacturer instructions. Dirty or damaged cooling equipment air filters may result in damage to the cooling equipment.
- The exterior HVAC equipment was installed under the eave without benefit of a roof water diverter flashing or rain gutter which may allow water and debris from the roof covering to damage the equipment.
- The HVAC ductwork insulation was observed to be damaged. Damaged HVAC ductwork insulation may allow conditioned air to escape into unwanted areas. Damaged HVAC ductwork insulation may create conducive conditions for condensation or other moisture intrusion defects.
- Ductwork installed in the crawl space was observed to be in contact with the ground and should be properly supported.
- The absence of airflow at heating/cooling supply registers was an indication of disconnected or damaged ducts. The cause of inadequate airflow at the heating/cooling supply registers should be determined and repaired as needed.
- Water supply lines in the crawl space were observed to lack adequate insulation. Lack of insulation or inadequate insulation at water supply lines in the crawl space should be corrected to prevent water damage.
- The tub/shower tile grout and sealants were observed to be in need of repair or replacement to prevent water penetration at interior walls. When tub/shower tile grout and sealants are damaged, there may be concealed water damage and or wood destroying insect damage.
- Surface damage was observed at the kitchen sink.
- There were gas fired appliances that did not have a "drip leg" installed. Under current construction standards, drip legs are required at the black iron gas pipe prior to a flexible gas line connection.
- Temporary accordion type plumbing at the waste drains should be repaired. Temporary plumbing at sink waste drains are a hidden fouling hazard and may cause water damage and create conducive conditions for wood destroying insects.
- Waste drains were slow to drain at sinks or tubs. The cause of slow drains should be determined and should be repaired or replaced as needed.
- The water heating equipment TPR valve had no drain line plumbing installed. Lack of properly installed TPR drain line plumbing may result in water damage and should be repaired by a qualified plumbing specialist.
- The dishwasher soap dispenser was not functioning properly. Dishwasher soap dispensers that do not perform as intended were an indication that repair or replacement is needed.
- Current building standards require that all bathrooms have installed a mechanical exhaust vent or an operable window to remove moisture from the air. Lack of an operable window or a mechanical exhaust vent in bathrooms is a deficiency and should be repaired.



- The exterior outbuilding wood veneer siding was observed to have some deterioration and/or damage. Damaged and deteriorated outbuilding exterior wooden siding should be repaired to prevent wall damage, moisture penetration and wood destroying insects.
- Weathered, deteriorated and/or damaged wood outbuilding materials were observed and should be repaired or replaced as needed.
- Roof penetration waste drain plumbing vents should be painted or wrapped with the appropriate protective material. PVC waste drain plumbing vents are susceptible to premature degradation due to exposure to sunlight.

### Improvement & "As Built Condition" Items

- No subfloor insulation was installed in the crawl space between the floor joists. Subfloor insulation prevents moisture intrusion and energy loss through the living space flooring.
- Inadequate grade slope away from the structure was observed.
- Grading and drainage could be improved with the installation of rain gutters. Properly installed rain gutters can prevent erosion and water ponding and help direct water away from the foundation.
- The attic insulation depth or thickness was inadequate. The recommended depth of attic floor insulation is 13+ inches to achieve an R38 rating. Inadequate attic insulation depth or thickness may allow greater than normal loss of conditioned air.
- The electric service panel breaker use was not labeled. Each electric service panel breaker should be adequately labeled as to what appliance or circuit it serves.
- Deficient Arc-Fault Protection (AFCI)** - The electrical system components did not appear to meet current arc-fault circuit-interrupter (AFCI) standards. ***This may be an "as-built" condition***, but according to today's local building standards, lack of AFCI protection is considered a deficiency. For more information, refer to Texas Real Estate Consumer Notice Concerning Recognized Hazards, form OP-I.
- There were one or more areas of the interior walls that lacked an electrical receptacle or the electrical receptacles were improperly spaced.
- Dual function breakers that provide both AFCI and GFCI protection are now available and became a National Electric Code (NEC) building standard in 2014. Under current electrical standards, AFCI protection is now required in family rooms, dining rooms, living rooms, parlors, libraries, dens, bedrooms, sun rooms, recreation rooms, closets, hallways, kitchens and laundry rooms. Lack of AFCI protection in required locations is a SAFETY HAZARD.

### Items To Monitor

- The structure has been built below the public street grade. Extra caution should be taken to prevent any possible water intrusion to the structure. Do not build flowerbeds that will cause a damming effect and hold water next to the structure. Positive drainage should always be maintained.
- Wooden deck construction materials were observed to be in contact with the ground. Wood to ground contact at decking construction materials creates conducive conditions for wood rot and wood destroying insects.

### Deferred Cost Items

- Cosmetic damages to ceiling should be repaired.

## **If Something Goes Wrong**

There may come a time when you discover something wrong with the house you purchased, and you may be upset or disappointed with your home inspection. There are some things we'd like you to keep in mind.

### **Intermittent Or Concealed Problems:**

Some problems can only be discovered by living in a house. They cannot be discovered during the few hours of a home inspection. For example, some shower stalls leak when people are in the shower, but do not leak when you simply turn on the tap. Some roofs and basements only leak when specific conditions exist. Some problems will only be discovered when carpets are lifted, furniture is moved or finishes are removed.

### **No Clues:**

These problems may have existed at the time of the inspection, but there were no clues as to their existence. Our inspections are based on the past performance of the house. If there are no clues of a past problem, it is often impossible for us to foresee a future problem.

### **We Sometimes Miss Minor Things:**

During our inspection we often discover minor problems while we are looking for the more significant problems. While we try to note as many of the minor problems as we can, we concentrate on finding the more significant problems. These are the ones that affect people's decisions to purchase.

### **Contractor's Advice:**

A common source of dissatisfaction with home inspectors comes from comments made by contractors. Contractor's opinions often differ from ours. You may have more than one roofing contractor say that the roof needs replacement, when we said that the roof would last a few more years with some minor repairs.

### **Last Man In Theory:**

While our advice represents the most prudent thing to do, many contractors are reluctant to undertake these repairs. This is because of the last man in theory. The contractor fears that if he is the last person to work on the roof, he will get blamed if the roof leaks, regardless of whether or not the roof leak is his fault. Consequently, he won't want to do a minor repair with high liability, when he could re-roof the entire house for more money and reduce the likelihood of a callback. This is understandable.

### **Most Recent Advice Is Best:**

There is more to the last man in theory. It suggests that it is human nature for homeowners to believe the last bit of expert advice they receive, even if it is contrary to previous advice. As home inspectors, we find ourselves in the position of first man in and consequently it is our advice that is often forgotten.

### **Why Didn't We See It?**

You may have a contractor say, I can't believe you had this house inspected, and the inspector didn't find this problem. There are several reasons for these **apparent** oversights:

A contractor may not know what is within the scope of a Home Inspection. The scope of a Home

Inspection is very specific, and all of our inspections are conducted in accordance with the Texas Standards of Practice for Home Inspectors. The Standards of Practice are very specific as to what is included and excluded from a home inspection.

**Conditions During The Inspection:** The conditions during the inspection are often very different than those when the contractor is present. It is often difficult for homeowners to remember the circumstances in the house at the time of the inspection. Weather conditions, temperature and time of day can drastically affect the way many of the home systems perform, leading to different results from the time of the inspection to the time the contractor is present in the home. It's impossible for contractors to know what the circumstances were when the inspection was performed.

**The Wisdom Of Hindsight:** When a problem manifests itself, it is very easy to have 20/20 hindsight, and wonder why the inspector was not able to predict a particular problem. As inspectors, we have been trained to look at all of the evidence available at the time of the inspection and give the most accurate prediction we can with the knowledge we have.

**A Limited Look:** We typically spent 3-4 hours to conduct a Home Inspection. During that limited amount of time, we cannot completely disassemble components or examine every hidden component location.

**We're Generalists:** We are generalists; we are not specialists. HVAC contractors, roofers, electricians, plumbers, etc may all indeed have more expertise than we do in their specific field. As inspectors, we are trained in all of the home systems and components, and look for general conditions that may indicate the need for further evaluation by a specialist.

**A Non-Invasive Look:** Problems often become apparent when carpets or plaster are removed, when fixtures or cabinets are pulled out, and so on. A home inspection is a visual examination. We don't perform invasive or destructive tests.

## **Not Insurance:**

In conclusion, a home inspection is designed to better your odds of not purchasing a "money pit". It is not designed to eliminate all risk. For that reason, a home inspection should not be considered a written guarantee or an insurance policy.