

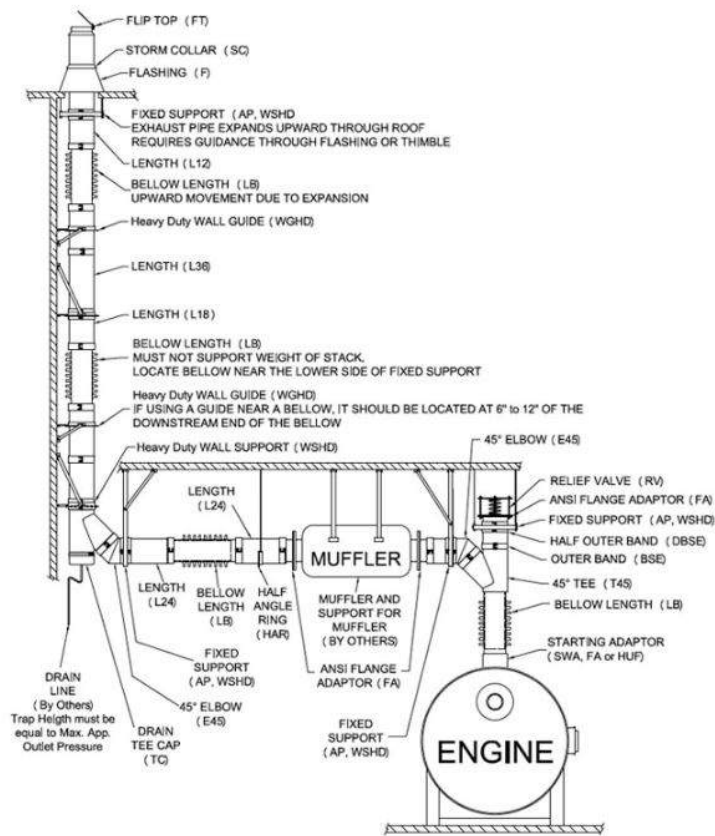

MODULAR ENGINE EXHAUST



Typical Installation for Diesel Generator Exhaust

Would you like to gain control and reduce the costs of your next emergency generator install? The following is a comparison that shows you what is to be gained by using a pre-fabricated exhaust system ready to install.

Chicago customers are finding that the modular pre-fabricated engine exhaust system is their new choice over the old black schedule 40 installs and here's why. In material list alone is, on average, a 15-20% cost savings compared to the schedule 40. The costs for each system included inner pipe, insulation, outer jacket, bellows, fixed and guide supports. Nice savings to be sure, but the much bigger savings were found in the labor costs. The modular pre-fabricated system is simply that. It comes in 304 stainless steel, 1", 2" or 4" wool insulation and galvanized outer jacket ready to install by one trade. The outer jacket is also available in 304 stainless steel for harsh conditions or for the portion of the stack exposed to weather. In all cases the black schedule 40 pipe took considerably more time to complete each connection, suspend from the structure, was harder to handle, still needed to be insulated and then the galvanized jacket applied requiring three trades. The logistics of scheduling the other two trades was also another consideration that was brought up several times. You can draw your own conclusions, but when the material cost is a considerable savings and the install time is typically done in less than half the time requiring only one trade, it's becoming a clear choice that DuraStack Pro is the preferred system for engine exhaust.

We hope the following technical information will be of benefit when considering your application. We are available to meet for product review and offer complete design layout with bill of materials from your contract drawings or field dimensioned sketches. Lead time for a complete system ready to install is 15-20 days direct to your facility or any project that can receive tractor trailers.

For more information please call, visit our website or email:

jeff@airtec-vents.com

www.airtec-vents.com 847.271.6067



AIRTEC

VENTING BY DESIGN

DuraStack® Pro

Models DAS1, DIS1, DIS2, and DIS4, Modular Double-Wall Positive Pressure Chimney for Boiler Breeching & Stack, Engine Exhaust, and Grease Duct.

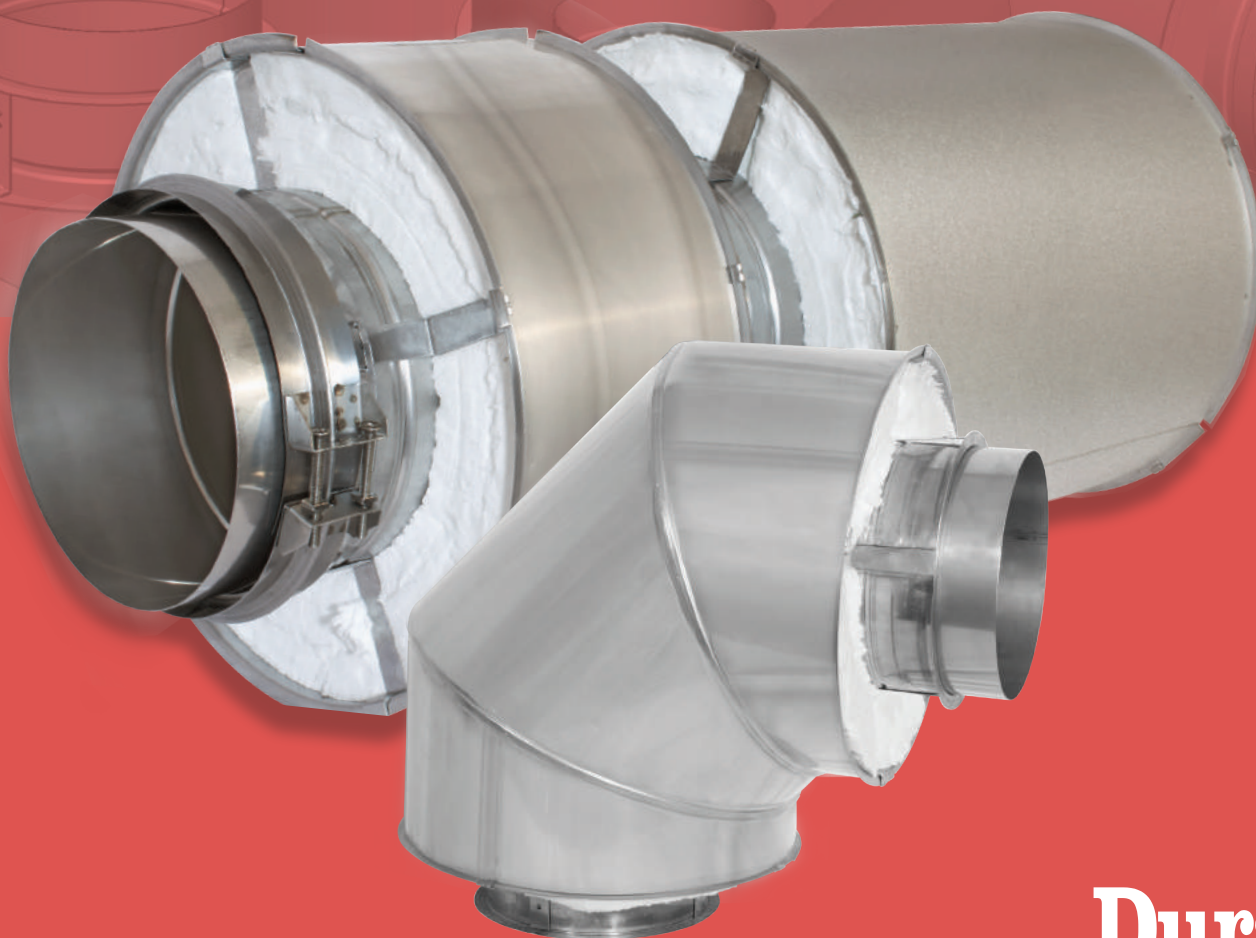

DuraStack® Pro

DuraVent®

DuraStack® Pro

Models DAS1, DIS1, DIS2, and DIS4, Modular Double-Wall Positive Pressure Chimney for Boiler Breeching, Stack, Engine Exhaust, and Grease Duct.

Applications

DuraStack Pro is available in the following configurations:

DAS1: 1" air insulated

DIS1: 1" insulated

DIS2: 2" insulated

DIS4: 4" insulated

Applications include: Low and High-Pressure Steam Boilers; Diesel and Turbine Exhaust; Building Heating Equipment. Industrial Furnaces; Processing Equipment; Kilns and Ovens.

Materials and Construction

Inner Wall Material Thickness

5" - 18" .035" Laser welded, 304 or 316

20" - 36" .035" Plasma welded, 304 or 316

Outer Wall Material Thickness

5" - 12" .024" Laser welded, 304 or 441, Galvalume

14" - 36" .024" Pittsburg Lock, 304 or 441, Galvalume

Diameters

5"-36"

Warranty

15 Years

Listings

USA:

- UL 103, 60-in. Positive Pressure and 1400°F Building Heating Appliance Chimney
- Type HT listing, for solid fuel application (only for Models DIS1, DIS2, DIS4, for diameter 5" to 24")
- UL 1978 Standard for Grease Duct

Canada:

- ULC/ORD C959 540°C (1000°F) and 760°C (1400°F) rating
- ULC S604, Type A chimney
- CAN/ULC S662 Standard for Factory-Built Grease Duct

DuraStack®

Pro

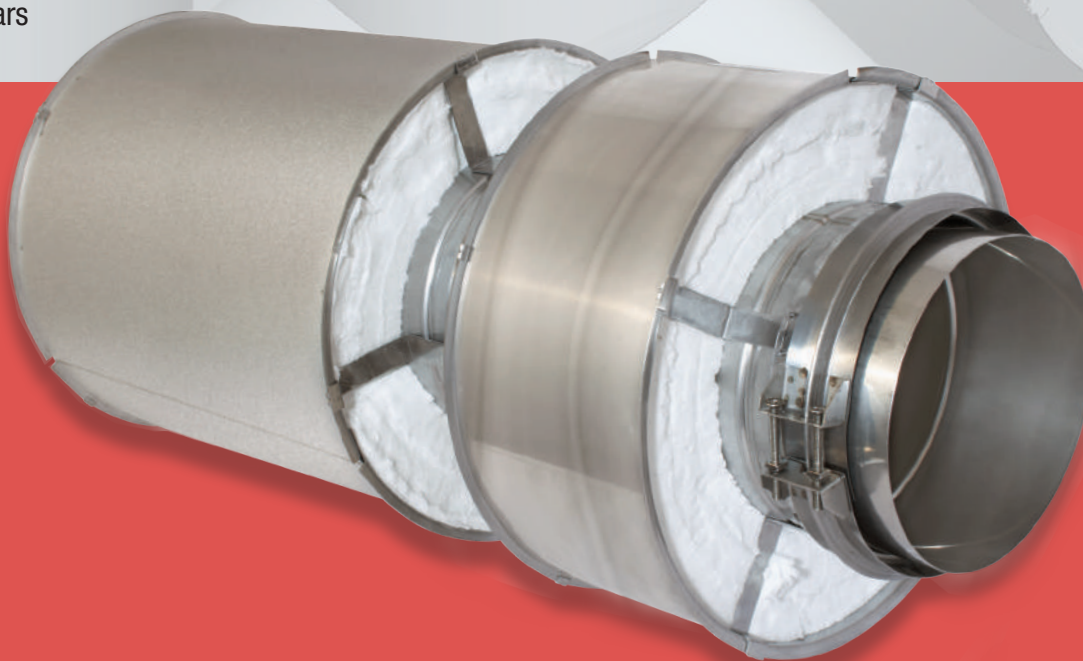

DuraVent®

www.airtec-vents.com

847.271.6067



L477_810013344_Sales Sheet_DuraStack Pro_05-24-17_V2

-Generator Exhaust-

PART 1 – BREECHING, CHIMNEY & STACKS

1. SCOPE

- 1.1. The factory built modular exhaust system shall be tested and listed by Underwriters Laboratories in the United States and Canada according to UL/ULC standard for use with medium heat equipment burning gas, liquid or solid fuels as described in NFPA-37 and NFPA-211, which produce exhaust flue gases at a maximum temperature of 1400°F (740°C) under continuous firing.
- 1.2. The chimney shall be listed for temperatures not exceeding 1400°F (740°C) under continuous firing and 1800°F (980°C) in brief forced firing according to UL-2561.
- 1.3. The exhaust system shall be listed by Underwriters Laboratories in accordance with UL103 to withstand up to 60-inch internal water column pressure at 1000°F (538°C).
- 1.4. The UL listed fiber insulated flue and air insulated flue system shall have surface temperatures published as per the UL-103 1000°F (538°C) chimney test.

PART 2 – CONSTRUCTION

2. CONSTRUCTION

- 2.1. Each DIS section shall be made of two steel cylinders separated by 1, 2 or 4 inch of high temperature AES Wool insulation. The published clearance to combustible shall be the result of UL/ULC listing of the standard.
- 2.2. Each DAS section shall be made two steel cylinders separated by 1 inch of air insulation. The published clearance to combustible shall be the result of UL/ULC listing of the standard.
- 2.3. The inner wall (flue) shall be constructed from 304 or 316 stainless steel, 0.035 inch thick. The outer wall (casing) shall be constructed from galvalume or 304 stainless, 0.024 inch thick.
- 2.4. Non-stainless steel surfaces exposed outside are recommended to be protected by a minimum of one base coat of primer and one finish coat of corrosion resistant paint suitable for high temperature. All primer and paint must be supplied by the contractor and shall be equivalent to series V2100 as manufactured by Rust-Oleum. An outer wall (casing) made of 304 or 316 stainless steel does not need to be painted.
- 2.5. The inner wall (flue) shall be laser or plasma welded.
- 2.6. All section joints shall have a self-centering sleeve to ensure proper alignment at the inner wall (flue).
- 2.7. All section joints are connected and sealed with a factory supplied locking band at the inner wall (flue) only. Use appropriate sealant as specified in the manufacturer's installation manual. Each section joint outer wall (casing) shall have a closure band.
- 2.8. The exhaust system shall be designed to compensate for thermal expansion.
- 2.9. Connections to mufflers/silencers shall be made with matching ANSI flanges.

PART 3 – EXECUTION

3. INSTALLATION

- 3.1. The installation shall be in accordance with the manufacturer's installation instructions and recommendations and shall conform to all applicable state and local codes.

DuraVent®

DURASTACK® PRO
MODELS DAS1, DIS1, DIS2, DIS4

- 3.2. All section joints are held in place by one mechanical locking band and sealed with appropriate sealant as recommended by the manufacturer's installation instructions and recommendations.
- 3.3. For Positive Pressure applications, apply the sealant as recommended by the manufacturers installation instructions and recommendations.
- 3.4. When installed according to the manufacturer's installation instructions, the exhaust and its supporting system shall resist side loads at least 1.5 times the weight per foot of piping.
- 3.5. The entire exhaust system from the appliance to the termination, including all accessories, except as noted, shall be from one manufacturer.
- 3.6. Roof/Wall penetrations shall be suitable for the specified roof construction and shall comply with the manufacturer's installation instructions.

PART 4 – WARRANTY

4. WARRANTY

- 4.1. The manufacturer shall warranty the exhaust system for *fifteen (15) years* from date of delivery for functional failure. See manufacturer's warranty for details.
- 4.2. The sizing of the complete exhaust system shall be guaranteed by the manufacturer and a copy of the sizing calculations submitted to the engineer for review and approval prior to the contractor placing an order and release.
- 4.3. The manufacturer shall submit an exhaust venting drawing for approval showing all exhaust vent system components. The contractor must position all exhaust venting components, equipment, water and gas piping to accommodate the exhaust vent system design.

PART 5 – PRODUCTS

5. MANUFACTURERS

- 5.1. Specification requirements shall be met by using DuraVent DuraStack Pro Models DAS1, DIS1, DIS2, DIS4 exhaust flue or equivalent as approved by the engineer. Equivalent submittals shall demonstrate that the alternate material is in compliance with all specification requirements.

Excessive Pressure Relief Valves:

Why They Belong on ALL Factory Built Generator Exhaust Systems



August 2018

There is one term that anyone who owns, operates, designs, or installs commercial power generation equipment should have in his or her vocabulary: Excessive Pressure Relief Valve (EPRV). Sometimes referred to as “explosion relief valves,” EPRVs are an essential component on any factory-built generator exhaust system, including those used for emergency back-up and cogeneration applications. Not only are they required per NFPA 37-2010, they are fundamental to ensuring safe operation of these systems. Unfortunately, EPRVs are often overlooked or even omitted to save costs. This paper will explain the role and functionality of these devices, where and how they should be installed, and why they should be recognized as a non-negotiable part of all factory-built generator exhaust systems.

Anatomy of a Backfire

The purpose of the EPRV on a factory-built generator exhaust system is to quickly relieve pressure in the event of an engine backfire.

Any generator engine can misfire or backfire, usually due to an equipment malfunction that is the result of a human error. Both diesel and gas fired generators are susceptible, but the consequences of a diesel engine backfires tend to be more dramatic. Diesel fuel is heavier, which increases the likelihood that uncombusted traces may collect on the inner surface of the exhaust vent, providing fuel for ignition from a spark due to an engine backfire.

The typical sequence of events in a generator backfire are as follows:

- Initial generator start-up fails (typically due to some mechanical malfunction). Although the start-up fails, some fuel is released into the vent system.
- During the next start-up attempt, a purge cycle is initiated to push fuel out of the vent. This lasts about one to two minutes. If, for some reason, the purge cycle is incomplete, some residual fuel may still be in the vent. Again, this is more likely with diesel systems because of the weight of the fuel.
- When ignition does occur any remaining fuel in the vent can ignite.
- If fuel is excessive, the ignition can create an explosion which sends a shockwave through the vent toward the exit point.
- Changes in direction of the vent piping and/or insufficient means for thermal expansion, and/or improper sizing creates excess pressure in the pipe, which may cause the pipe to break apart, possibly damaging surrounding property or causing physical harm.

While such events are rare, they are far from unprecedented. When they do occur, they have the potential to damage the generator exhaust system and other property, resulting in financial hardship to the owner. The inclusion of an EPRV on factory-built generator exhaust helps reduce the severity and consequences of these types of explosions.

EPRV Application and Operation

EPRVs are specifically designed to instantly release any pressure that exceeds the maximum allowable back pressure on the generator. The application of EPRVs on generator exhaust systems is relatively straightforward. Typically, the mechanical engineer provides the exhaust duct manufacturer with the make and model of the generator and muffler, along with the maximum allowable backpressure. The exhaust

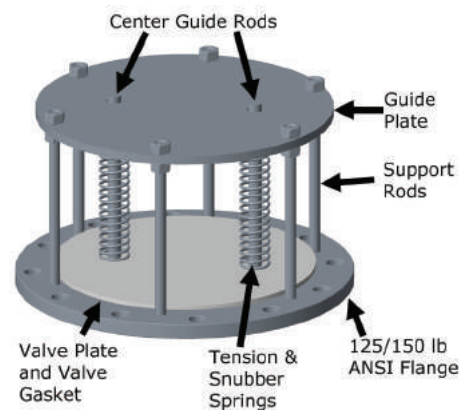
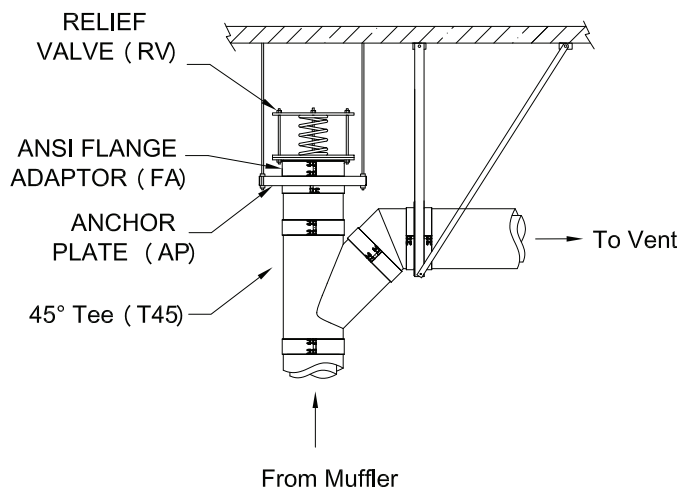

manufacturer performs the necessary calculations to size the EPRV and then supplies the valve along with the associated bolts, washers, nuts and gasket to provide a gas tight connection.

EPRVs should be located close to the engine and at the first directional change in the exhaust pipe. This placement helps protect the engine and vent system from an incident due to back pressure. Because an EPRV may release very hot gases and/or flames, it should never be installed where any human contact can occur or near any flammable or combustible materials.

Under normal operating (non-event) conditions, the valve is spring-loaded to remain closed. If back pressure rises beyond the setting, typically 27-inches of water column (1 PSI), the valve plate opens rapidly to relieve the pressure. The valve includes two springs, a tension spring and a snubber spring that keeps the tension spring from fully collapsing while maintaining the design “open” pressure of the valve. Following a backfire event, the valve seat gasket should always be inspected for damage, as this could prevent the valve from maintaining a fully closed (gas tight) position during normal operation. Backfiring can also dislodge the seat gasket, causing metal to metal seating and subsequent damage to the valve.

Overlooked and Misunderstood

Some contractors and even engineers may omit the EPRV, reasoning that generator exhaust systems are open and any sudden, unexpected pressure will simply be released out the top of the vent stack. If the generator is piped with field-welded carbon steel that might be a safe bet. Field-welded pipe is thicker and, if designed and installed properly, it should be able to withstand sudden spikes in exhaust pressure. That said, fewer and fewer engineers specify field-welded systems for generator exhaust, opting for factory-built exhaust systems instead.

“In lieu of steel piping with field-applied insulation and applied expansion fittings, many engineers find it more convenient and cost-effective to specify a pre-engineered listed double-wall exhaust flu system offered by many of the same manufacturers that sell boiler exhaust flues. This type of product is already insulated, and the manufacturer includes the expansion fittings, guides and anchors, plus the technical expertise to properly select same.”¹

Factory-built systems are in fact quickly becoming the norm simply because they offer so many advantages over field-welded systems. These systems arrive at the jobsite in easy-to-assemble, double-wall components that require no welding. They are pre-insulated for close clearance, so no additional field wrapping is required. They are lighter weight, install faster and they look better. But because factory-built systems are constructed of a thinner gauge stainless steel, they do require an EPRV to vent excess pressure in the event of a backfire. This requirement is inferred by NFPA 37-2010 Paragraph 8.1.4, which states:

"Exhaust systems shall be designed and constructed to withstand forces caused by the ignition of unburned fuel or shall have provisions to relieve those forces without damaging the exhaust system." ²

It is important to remember that a single 90-degree bend in the exhaust pipe adds additional footage to the system and thus additional resistance/back pressure within the exhaust system. Furthermore, any back pressure that is not accounted for within the design of the system increases the chance and severity of an explosion, a fact that underscores the importance of the EPRV.

The Cost of Compliance

Cost, combined with a lack of understanding, explains why EPRVs are so frequently absent from generator exhaust systems.

EPRVs must be able to withstand tremendous force and temperatures as high as 1400°F (760°C). Because of this they are made of heavy duty, exotic materials, which is reflected in their price tag. The cost of EPRVs increases with the diameter of the exhaust pipe and on large systems may elicit sticker shock from contractors, especially if they do not fully understand the role of the valve. If a contractor inadvertently fails to include this cost in his or her quotation, only to discover it after being awarded the project, it may be very tempting to omit the valve from the installation. In the United States, there is a fair chance that the inspector will be none the wiser. While EPRVs are required in theory, this requirement is far from common knowledge in the States. (Note: Canadian inspectors do practice strict enforcement of NFPA 37 and few if any emergency generator exhaust systems are installed in Canada without EPRVs.)

While best practices and codes regarding excessive pressure relief in generator exhaust systems may be largely misunderstood or overlooked by installers and even code officials, verbiage advocating the installation of EPRVs can be found in the application and installation guides of most, if not all, of leading manufacturers of standby generator equipment, including Caterpillar and Generac:

"The minimum requirements for the design of the exhaust system should be to contain explosions that could be encountered during the operation of the engine. Caterpillar recommends the use of explosion relief valves on all gas engines, particularly for the larger size engines due to the high fuel volumes. Explosion relief valves should be located as close to the engine as possible (typically at piping elbows) to minimize any potential exhaust system damage in the event of an exhaust explosion." ³

"The minimum requirements for the design of the exhaust system should be to contain explosions that could be encountered during the operation of the engine. The use of explosion relief valves is recommended on all gas engines, particularly the larger size engines due to high fuel volumes." ⁴

The only time an EPRV may be justifiably omitted from a factory-built exhaust system is when the pipe runs vertically out of the top of the generator and makes no directional changes.

Safety Equals Making EPRVs Non-Negotiable

Clearly everyone involved in the selection, installation, inspection and even ownership of standby generators bears some of the responsibility for the safe operation of this equipment. Manufacturers of pre-fabricated exhaust equipment also have a responsibility to do everything they can to ensure the inclusion of EPRVs on generators. Educating all of the above parties on the importance of EPRVs is certainly useful, as are manufacturer recommendations, but neither is enough to ensure that EPRVs will always be installed.

In the interest of promoting safe systems and full compliance with NFPA 37, Security Chimneys has taken a bold step by including EPRVs as a standard part of their Secure Stack Pro Series line of exhaust systems.

“Other manufacturers of exhaust equipment include EPRVs as an option for generator applications. We actually insist that every generator job has a relief valve,” said Don McInroy, National Sales Manager for DuraVent and Security Chimneys.

Until awareness and understanding of NFPA 37 catches up with the proliferation of factory-built exhaust systems on generator applications, specifying a manufacturer that includes EPRVs on all generator exhaust systems may be the only way that engineers and owners can ensure that these systems are installed for maximum safety and code compliance.

¹ Duda, Stephen. April 2016. “Engine Cooling For Emergency Power Generations Systems.” Ashrae Journal: 54-60.

² NFPA 37-2010, Standard for Installation and Use of Stationary Combustion Engines and Generators. Quincy, Mass. : National Fire Protection Associations.

³ Caterpillar. (2013). Exhaust Systems: Applications and installations guide. Peoria, IL: Author.

⁴ Generac. (2013). Stationary Industrial Generators: Installation guidelines. Waukesha, WI: Author.

For more information and literature please visit:
www.duravent.com • www.securitychimneys.com

DuraVent[®]

