

# Single Lumen Alternating Micro-Batch Hemodiafiltration (SLAMB-HDF): A Device for Minimally Invasive Renal Replacement Therapy

Lakhmir S. Chawla 

## Abstract

**Blood-based RRT, such as hemodialysis, requires access to the bloodstream and adequate blood flow to enable the requisite clearance. As such, nearly all RRT systems require two lumens, enabling a blood circuit that pulls blood from one lumen or needle and returns it *via* another lumen or needle. The proposed single lumen alternating micro-batch (SLAMB) technique uses a small single lumen to draw a “micro” batch of blood into a single reservoir. In the reservoir, the “batch” of blood is circulated at a high blood flow rate through a hemofilter or hemodialyzer, enabling efficient small- and middle-molecule clearance. Thereafter, the “purified” blood is returned to the patient and the cycle is repeated. Each batch comprises 20–300 ml of blood, which is adjusted to the vascular access, hemodynamic status, and size of the patient. Up to 15 cycles can be done per hour, allowing this system to achieve a blood clearance level comparable to modern continuous RRT systems. Because the system can function with a small-bore single lumen, this device can work with existing central lines, thus allowing for less invasive vascular access. Because of their size and relative simplicity, SLAMB-based systems are less expensive, smaller, and have improved portability. Lastly, a similar, manual SLAMB-hemofiltration kit, which requires no electricity or battery, can be developed at low cost (<\$25) for use in austere medical conditions, thus expanding the availability of RRT for patients with AKI.**

KIDNEY360 1: 969–973, 2020. doi: <https://doi.org/10.34067/KID.0001462020>

## Introduction

Modern, blood-based RRTs, such as hemodialysis and hemofiltration, require access to the blood compartment and adequate blood flow to enable the required clearance for the RRT prescription. As such, nearly all RRT systems require two lumens, enabling an afferent and efferent limb to create a blood circuit that pulls blood from one lumen or needle and returns it *via* another lumen or needle. Additionally, achieving high levels of solute clearance requires high blood flow, thereby necessitating large-bore vascular access. As an example, to conduct a typical RRT treatment, a dual-lumen catheter with a diameter of 11–13 French (Fr), an arteriovenous graft, or a mature arteriovenous fistula is required. All of these vascular access types require maintenance to assure patency and are associated with potential complications.

The device concept proposed in this technical note is a modernization of the first hemodialysis ever performed. The first successful hemodialysis procedure was performed using a drum dialyzer, wherein a sausage casing made of cellophane was wrapped around a cylinder which was immersed in a large drum filled with dialysate (Figure 1). The patient was phlebotomized and the blood was placed into a jug with an anticoagulant (*i.e.*, heparin). This “batch” of blood was then placed into the sausage casing membrane and submerged into the dialysate, thereby allowing a diffusive dialysis effect. After this procedure was

completed, the dialyzed blood was drained into a second jug which was then transfused back into the patient. This procedure was repeated multiple times until an adequate clearance was achieved, and this series of “drain-refill” procedures comprised the first successful dialysis treatment(s) (1).

The treatment outlined above was cumbersome and took about 6 hours to complete. Therefore, an approach using an afferent/efferent circuit was pursued to improve the efficiency of the treatment, and this basic technique is still the basis of modern RRT. The device described below maintains the advantages but eliminates the cumbersome features of the initial batch concept by using modern pump, scale, and filter technology.

## Description

To operate the device, an intravascular catheter that is patent and can reliably withdraw up to 300 ml of blood is all that is required. The single lumen alternating micro-batch (SLAMB) technique uses a small single lumen to draw a “micro” batch of blood into a single reservoir (Figure 2). If the patient is not already anticoagulated, a small amount of anticoagulant (*e.g.*, heparin, citrate) is added to the reservoir first. A small batch of blood ranging from 20 to 300 cc of blood is added to the reservoir. Once the blood is in the reservoir, the blood is dialyzed and/or hemofiltered at

Veterans Affairs Medical Center, San Diego, California

**Correspondence:** Dr. Lakhmir S. Chawla, Veterans Affairs Medical Center, 3350 La Jolla Village Drive, San Diego, CA 92161. Email: [minkchawla@gmail.com](mailto:minkchawla@gmail.com)



**Figure 1.** | Picture of a patient being treated with a Kolff drum dialyzer.

a high blood flow rate and a high dialysate flow rate for 1–3 minutes. The blood is recirculated back into the reservoir after it is dialyzed, so the same blood can be reprocessed

multiple times, thus allowing rapid and high-efficiency clearance of solutes and ultrafiltration as needed. Once the blood is purified, the blood is returned to the patient along with an anticoagulant-reversal agent if needed (*i.e.*, protamine, calcium). This procedure is repeated until the desired level of clearance and ultrafiltration are achieved. The time for one full cycle (blood drawn in, hemodiafiltration, blood returned) is dependent on the size of the batch and the vascular access. Assuming a batch of 200 cc and a single lumen of a standard central line, the entire cycle would take 4–7 minutes, allowing eight to 15 batches per hour.

## Results

Schematics and animation of the proposed SLAMB systems are shown in Figures 2 and 3 and Supplemental Figures 1–5.

Clearance rates and times have been modeled and shown in Supplemental Table 1 and Table 1. Supplemental Tables 2 and 3 outline the manual SLAMB dialysate and approximated costs, respectively.

## Discussion

A concept known as “single-needle dialysis” was proposed by Kopp *et al.* (2) in 1972, and this type of RRT has been used since that time with varying degrees of enthusiasm (3). Currently, there are two single-needle devices available in Europe, the Dialog iQ (Braun) and FMC 5008 (Fresenius), both of which have vastly improved the original concept (4). The Dialog iQ and the FMC 5008 offer the

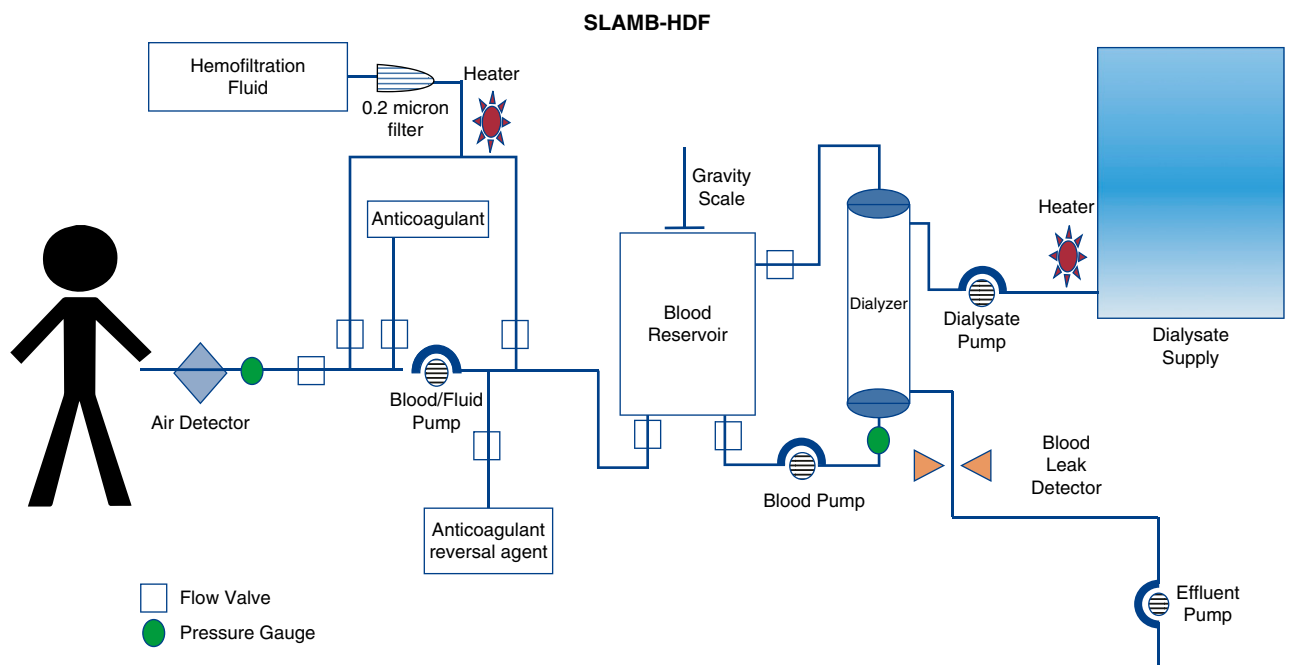

**Figure 2.** | Configuration of the SLAMB-hemodiafiltration (HDF). The configuration depicted can perform hemoperfusion, hemofiltration, hemodialysis, aquapheresis, or hemodiafiltration. SLAMB, single lumen alternating micro-batch.

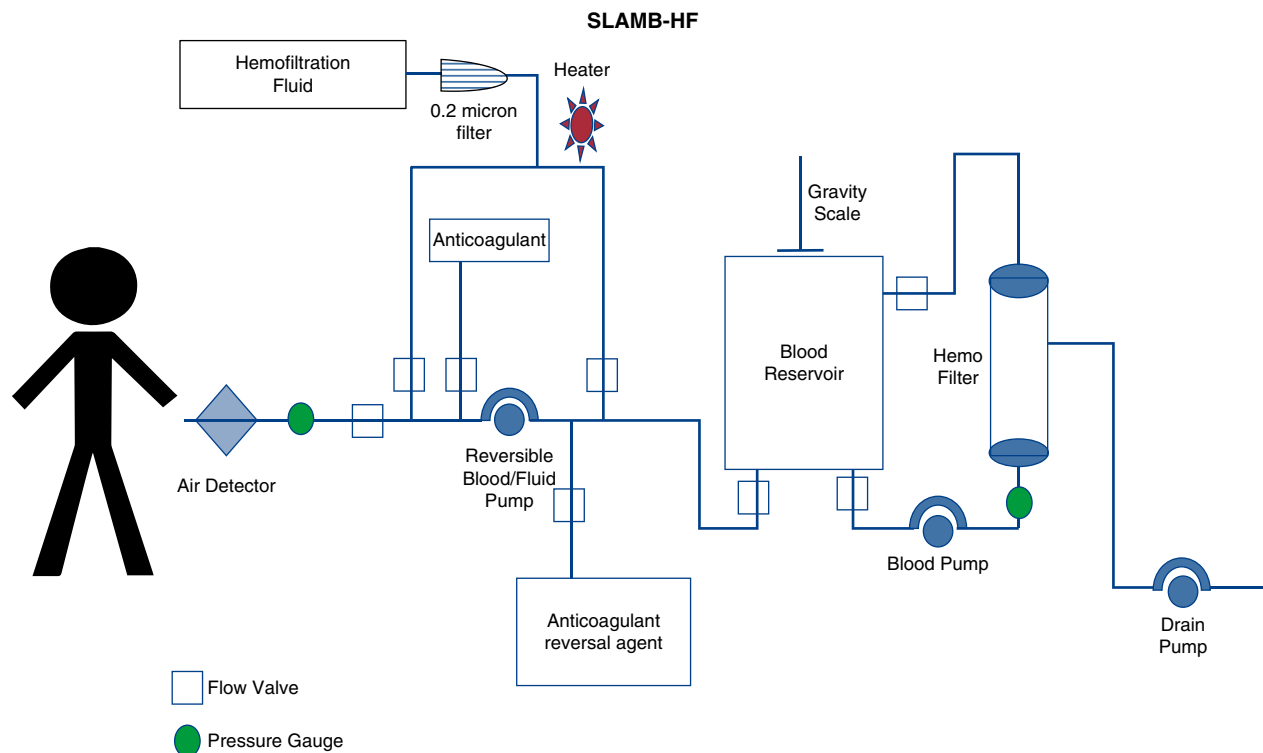

**Figure 3. | Configuration of SLAMB-hemofiltration (HF).** Simplified SLAMB designed for hemofiltration only. This configuration only requires three pumps. SLAMB-HF, single lumen alternating micro-batch–hemofiltration.

benefit of a single needle, yet maintain the familiar arterial and venous circuit through which blood is dialyzed, and they use a large gauge needle (14 or 15 gauge) or large-bore

central line. The Dialog iQ and FMC 5008 systems can both perform an intermittent therapy, albeit with reduced efficiency compared with standard intermittent machines (3,4).

**Table 1. SLAMB dosing models based on various prescriptions**

Batch Size (ml)	Total Cycle Time (min)	Reservoir Cycle Time (min)	Time to Achieve Dose of 20 cc/kg per Hour (h)	Intravenous Access Minimum Flow Rate Requirement (ml/min)
100 <sup>a</sup>	3	2	17.9	200
100 <sup>a</sup>	3.5	2	20.8	133
100 <sup>a</sup>	4	2	23.8	100
150 <sup>a</sup>	4	2	15.9	150
150 <sup>a</sup>	4	2.5	15.9	200
150 <sup>a</sup>	5	2.5	19.8	120
150 <sup>a</sup>	6	2.5	23.8	85.7
200 <sup>a</sup>	4	3	11.9	400
200 <sup>a</sup>	5	3	14.8	200
200 <sup>a</sup>	6	3.5	17.8	160
200 <sup>a</sup>	7	3.5	20.8	114
200 <sup>b</sup>	3	2	8.9	400
250 <sup>b</sup>	3.5	2	8.3	400
250	5	3	11.8	250
250	6	4	14.2	250
250	7	4	16.6	167
300	6	4	11.8	300
300	7	4	13.8	200
300	8	4	15.7	150

The dosing models assume a 75-kg subject, no ultrafiltration, and that the distribution of urea is the same as the total body water. Dose goal is Kt/V of 0.8 (equivalent to 20 cc/kg per hour for 24 h) (8). SLAMB, single lumen alternating micro-batch.

<sup>a</sup>SLAMB prescriptions that would likely be used for patients who are critically ill.

<sup>b</sup>Prescriptions that could be used for home dialysis.

These devices are good options for patients who can only tolerate a single needle, but can have significant recirculation. In addition to the above systems, a device called the Newcastle Infant Dialysis and Ultrafiltration System (NI-DUS) has been developed for neonates that uses a single-lumen system, comprising two reservoirs made up of two low-volume syringes to conduct precise hemofiltration. NI-DUS is designed specifically for low-weight children (5).

The SLAMB-hemodiafiltration (HDF) system builds on these initial concepts and is designed for larger patients, a longer duration of therapy, and would be better suited for continuous RRT, aquapheresis, slow continuous ultrafiltration, periodic intermittent RRT, nocturnal dialysis, and/or daily home dialysis. There are multiple advantages to the proposed SLAMB-HDF technique over current dual-lumen RRT systems. First, this technique can occur *via* a small single-lumen catheter (*i.e.*, one lumen of a standard triple-lumen central line or a small single needle), potentially easing the burden of vascular access in both acute and chronic RRT patients. Second, because the blood is held in a reservoir and recirculated, this system disentangles the usual need of large vascular access and high blood flow to achieve high middle-molecule and protein-bound uremic toxin clearance. Third, because the blood is held in a reservoir, this system can also be used for hemoperfusion, aquapheresis, and other extracorporeal therapeutics. Fourth, because blood batches are small and anticoagulated, a small hemofilter can be used, thus decreasing the cost. Fifth, the small batch and small filter can allow for a small device that takes up less space and increases portability. Sixth, the intravenous (IV) access attached to the SLAMB device can also be used to administer regular IV medications while performing RRT; this is possible because the device has three cycles: (1) “withdraw blood,” (2) “process blood,” and (3) “return blood” (Supplemental Figures 1–3). Thus, during the process-blood and return-blood phase, a separate IV pump synchronized to the SLAMB device can continue to administer other IV medications and pause infusion during the withdraw-blood phase. In essence, a patient with an existing central line can have RRT initiated without the loss of that lumen for giving other medications. Seventh, the absence of a dual-lumen catheter precludes the inefficiencies due to blood recirculation. Lastly, the batch size can be customized for the size and severity of illness of the patient. Theoretically, having a smaller amount of blood leave the circulation should decrease the hemodynamic instability often seen when a RRT session is initiated.

However, there are some disadvantages to the proposed system. First, the small batches preclude this device for being used for a standard intermittent RRT session, because the time for the push/pull and dialysis/hemofiltration to occur would take too long to generate the requisite clearance over the short period of time (*e.g.*, 3–4 hours). Second, due to the batching, systemic anticoagulation or “regional” anticoagulation is required, which may be inappropriate in some patients.

#### SLAMB-Hemofiltration for Use in Austere Conditions

A simpler version of this device that uses only hemofiltration is shown in Figure 3. In this system, the blood from the patient is drawn into the reservoir, along with a small

amount of anticoagulant and hemofiltration fluid (sterile crystalloid or similar hemofiltration fluid). The reservoir is then rapidly hemofiltered, and the blood is then returned to the patient. Because this system does not require high-flow pumps and relies exclusively on hemofiltration, the overall system is small and requires only three small pumps and one gravity scale. (Figure 3) This low-power system can run on a battery and its capacity to work with a small single-lumen catheter makes it appealing in places where full nephrology services are not available. The overall cost for this simple, minimally invasive system would be <\$1000 per machine and can use known standard technology, making maintenance and repair inexpensive and tractable.

A fully manual syringe mode of the SLAMB-hemofiltration (SLAMB-HF) system is shown in Supplemental Figure 4. Although this system is labor intensive, it is “powered” manually with two 50-cc syringes, six three-way stopcocks, one hemofilter, two bags, and IV tubing. This manual version of the SLAMB-HF system does not require any electricity and would have a total cost of <\$25 per kit. Although not ideal, a combination of 1 L 5% dextrose in normal saline and 4 L Hartmann solution (*i.e.*, lactated Ringer solution) make an adequate hemofiltration solution to manage uremia, acidemia, and hyperkalemia (Supplemental Table 2). Because these sterile IV fluids are inexpensive and widely available, a simple, manual SLAMB-HF machine coupled with these fluids could allow for adequate RRT for patients with AKI who are likely to recover renal function (*i.e.*, rhabdomyolysis). The manual SLAMB would require training to be implemented properly, but the technical operation is simple and could be taught to a combat medic, nurse, or other skilled healthcare professional, thus expanding the availability of RRT. An example where this might be useful is in the immediate aftermath of an earthquake. Many earthquake survivors suffer crush injury and associated rhabdomyolysis with severe AKI. The provision of RRT could prove lifesaving in many of these patients. An inexpensive RRT system that can be deployed with low-cost IV fluids and does not require power may be advantageous. In addition, the placement of a peritoneal catheter or a double-lumen catheter can be challenging in an austere environment because both require technical expertise. Because the SLAMB systems require more modest vascular access, RRT may be more feasible and safer with this system in an austere environment. The International Society of Nephrology has initiated the 0by25 program and, if the manual SLAMB-HF system is developed and deployed, it may improve the availability of RRT for patients with AKI and mitigate otherwise preventable deaths (6).

#### Dose, IV Access, and Anticoagulation Considerations

In general, the cycle time and, therefore, total dose of RRT requires an adequate IV access. A standard, double-lumen dialysis catheter of 11 Fr (each lumen of 5–5.5 Fr) can run a blood flow rate of 200–300 ml/min. Thus, a single-lumen catheter of at least 5 Fr can easily allow batches of 200–250 ml to be drawn into the SLAMB in 1 minute and returned in 1 minute. Single-pass urea clearance in hemodialysis ranges from between 85% and 90%, thus a batch of 200–250 ml can then be (re)cycled at 200–400 ml/min within the reservoir for 2–3 minutes to achieve 90%–95% clearance



(7). Therefore, a conservative estimate of the total cycle time with a single-lumen catheter of 5 Fr is as follows: 5 minutes (1 minute ingress, 2–3 minutes of clearance, 1 minute blood return), which would allow 12–15 cycles per hour. If the urea distribution is assumed to be the same as total body water, the standard continuous RRT dose of 20 ml/kg per hour equates to a Kt/V of 0.8 (8). Modeling of different SLAMB prescriptions is shown in Table 1. In the above example, a 75-kg patient dosed with a SLAMB prescription of 200 cc batch, 5-minute cycle time, 0 ml of ultrafiltrate would achieve a Kt/V of 0.8 in 14.8 hours. If smaller/longer IV access were used, thus extending the cycle time, the time to achieve a Kt/V would be extended. In this example, if the ingress/egress of blood from the device were extended to 9 minutes (3 minutes cycling, 3 minutes for ingress, and 3 minutes for egress), a catheter would need to be able to enable a blood flow rate of at least 67 ml/min, and a Kt/V of 0.8 could be achieved in 24 hours.

Because the SLAMB system uses small batches that are resident in a reservoir, some element of anticoagulation is a prerequisite. However, the amount of anticoagulant (*i.e.*, heparin/sodium citrate) per ml of blood to enable the batch operation is not yet known. Future research in the development of this proposed system will need to be done to understand the anticoagulation dosing parameters.

## Conclusion

A SLAMB-HDF platform is a concept that may allow RRT to be conducted with a single and smaller vascular access. Systems based on this design are simpler than current RRT systems, making them less expensive, lighter, and more portable, thus increasing the options for patients who require RRT.

## Disclosures

L. Chawla reports submitting patents on the SLAMB design and concept.

## Funding

None.

## Acknowledgments

The author would like to thank Dr. David Askenazi, Dr. Pat Brophy, Dr. Stuart Goldstein, Prof. Lui Forni, and Dr. Samir Patel for their constructive critiques and advice.

## Author Contributions

L. Chawla conceptualized the study, was responsible for data curation, provided supervision, wrote the original draft, and reviewed and edited the manuscript.

## Supplemental Material

This article contains the following supplemental material online at <http://kidney360.asnjournals.org/lookup/suppl/doi:10.34067/KID.K3602020000146/DCSupplemental>.

Supplemental Table 1. SLAMB dose modeling.

Supplemental Table 2. Manual SLAMB-HF supplies and approximated costs.

Supplemental Table 3. Hemofiltration fluid made with 5% dextrose/normal saline and lactated Ringers solution.

Supplemental Figure 1. SLAMB – HDF animated.

Supplemental Figure 2. SLAMB – HF animated.

Supplemental Figure 3. SLAMB – HD animated.

Supplemental Figure 4. Manual syringe SLAMB system animated.

Supplemental Figure 5. SLAMB – hemoperfusion.

## References

1. Twardowski ZJ: History of hemodialyzers' designs. *Hemodial Int* 12: 173–210, 2008
2. Kopp KF, Gutch CF, Kolff WJ: Single needle dialysis. *Trans Am Soc Artif Intern Organs* 18: 75–81, 1972
3. Vanholder R: Single needle hemodialysis: Is the past the future? *J Nephrol* 33: 49–58, 2020
4. Bieser W, Welsch M, Jakob M, Meibaum J, Rodriguez DA, Wolff H, Marcelli D, Barth C: Effectiveness of a new single-needle single-pump dialysis system with simultaneous monitoring of dialysis dose. *Artif Organs* 42: 814–823, 2018
5. Coulthard MG, Crosier J, Griffiths C, Smith J, Drinnan M, Whitaker M, Beckwith R, Matthews JN, Flecknell P, Lambert HJ: Haemodialysing babies weighing <8 kg with the Newcastle infant dialysis and ultrafiltration system (Nidus): Comparison with peritoneal and conventional haemodialysis. *Pediatr Nephrol* 29: 1873–1881, 2014
6. Mehta RL, Cerdá J, Burdman EA, Tonelli M, García-García G, Jha V, Susantitaphong P, Rocco M, Vanholder R, Sever MS, Cruz D, Jaber B, Lameire NH, Lombardi R, Lewington A, Feehally J, Finkelstein F, Levin N, Pannu N, Thomas B, Aronoff-Spencer E, Remuzzi G: International Society of Nephrology's Oby25 initiative for acute kidney injury (zero preventable deaths by 2025): A human rights case for nephrology. *Lancet* 385: 2616–2643, 2015
7. Macías N, Vega A, Abad S, Aragoncillo I, García-Prieto AM, Santos A, Torres E, Luño J: Middle molecule elimination in expanded haemodialysis: Only convective transport? *Clin Kidney J* 12: 447–455, 2018
8. Vijayan A, Palevsky PM: Dosing of renal replacement therapy in acute kidney injury. *Am J Kidney Dis* 59: 569–576, 2012

Received: March 23, 2020 Accepted: July 30, 2020

## **Supplemental Material Contents**

Supplemental Table 1, SLAMB Dose Modeling

Supplemental Table 2, Manual SLAMB-HF Supplies and Approximated Costs

Supplemental Table 3, Hemofiltration Fluid Made with 5% Dextrose/Normal Saline and Lactated Ringers Solution

Figure S1, SLAMB – HDF Animated

Figure S2, SLAMB – HF Animated

Figure S3, SLAMB – HD Animated

Figure S4, Manual Syringe SLAMB system animated

Figure S5, SLAMB - Hemoperfusion

Supplemental Table 1, SLAMB Dose Modeling

Weight (kg)	Batch Size (ml)	Cycle Number	Baseline BUN (mg/dl)	Urea Clearance	New BUN (mg/dl)	Cycle Time (minutes)	Total Time
75	150	1	100	95%	99.6833333	4	4
75	150	2	99.6833333	95%	99.3676694	4	8
75	150	3	99.3676694	95%	99.0530052	4	12
75	150	4	99.0530052	95%	98.7393373	4	16
75	150	5	98.7393373	95%	98.4266627	4	20
75	150	6	98.4266627	95%	98.1149783	4	24
75	150	7	98.1149783	95%	97.8042809	4	28
Model progresses until target BUN is achieved							

Legend: TBW = total body water; BUN = blood urea nitrogen;  $C_0$  = Baseline BUN

Equations: 
$$\text{New BUN} = \frac{C_0 * \{ \text{TBW} - (\text{Batch size [liters]} * \text{Clearance}[\%]) \}}{\text{TBW}}$$

$$\text{TBW} = \text{weight (kg)} * 0.6 \text{ (liters)}$$

Supplemental Table 2, Manual SLAMB-HF Supplies and Approximated Costs

Supplies	Costs (dollars)
Two 50 cc syringes	1.50
Six 3-way stopcocks	3.00
1 Hemoconcentrator	11.00
IV Tubing	5.00
Two 1-liter reservoir bags	2.00
Graduated Cylinder (disposable)	1.50
<b>Total Cost: \$25.00</b>	



Supplemental Table 3, Hemofiltration Fluid Made with 5% Dextrose/Normal Saline and Lactated Ringers Solution

	LR	LR x 4	D5/NS	Combined	Final Concentration
Na (meq)	130	520	154	674	134.8
K (meq)	4	16	0	16	3.2
Cl (meq)	109	436	154	590	118
Ca (meq)	2.7	10.8	0	10.8	2.16
Lactate (meq)	28	112	0	112	22.4
Dextrose (%)	0	0	5	5	1
Volume	1 liter	4 liters	1 liter	5 liters	1 liter

# SLAMB-HDF

Figure S1a

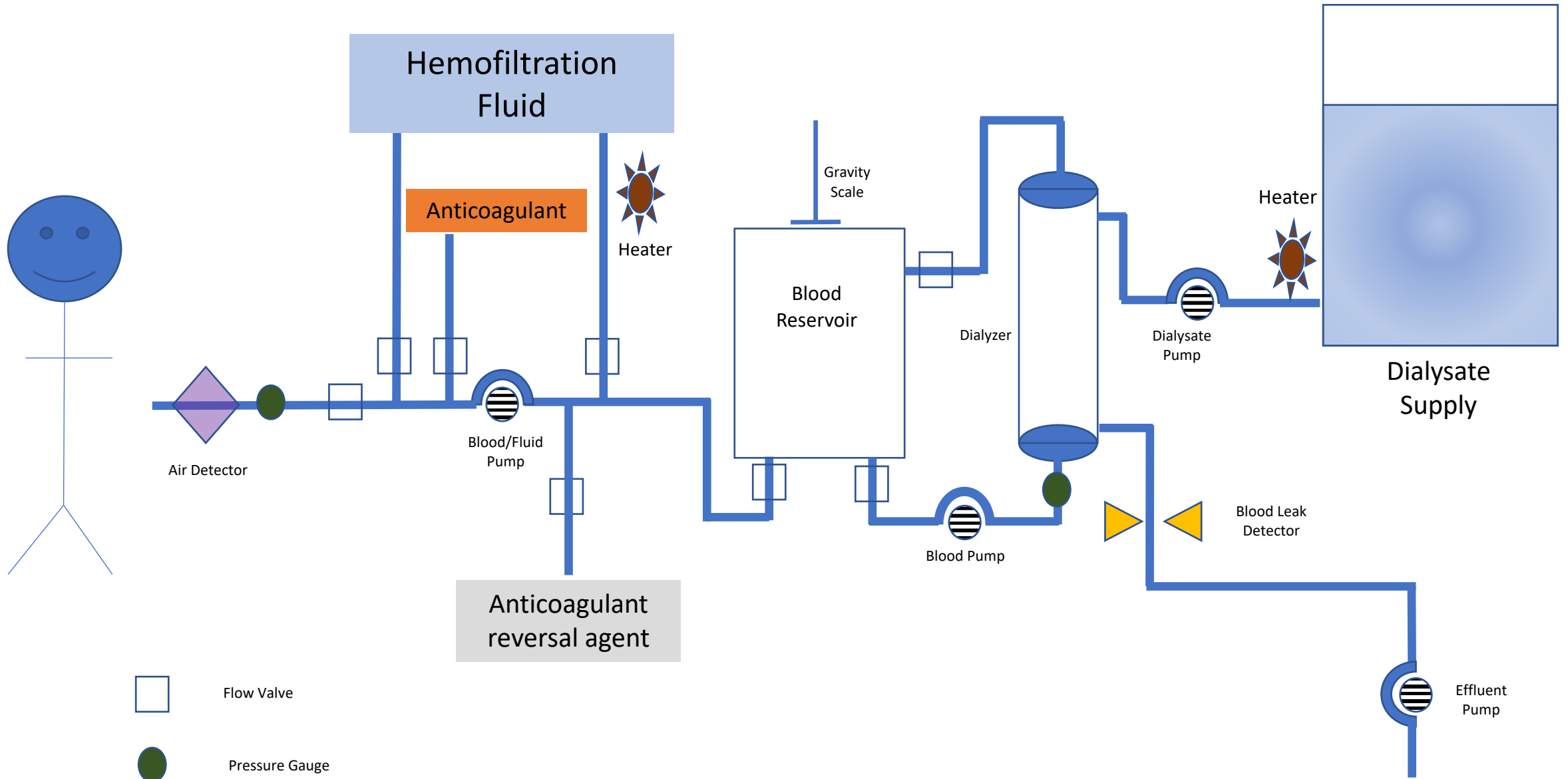

# SLAMB-HDF

## Anticoagulant Fill

Figure S1b

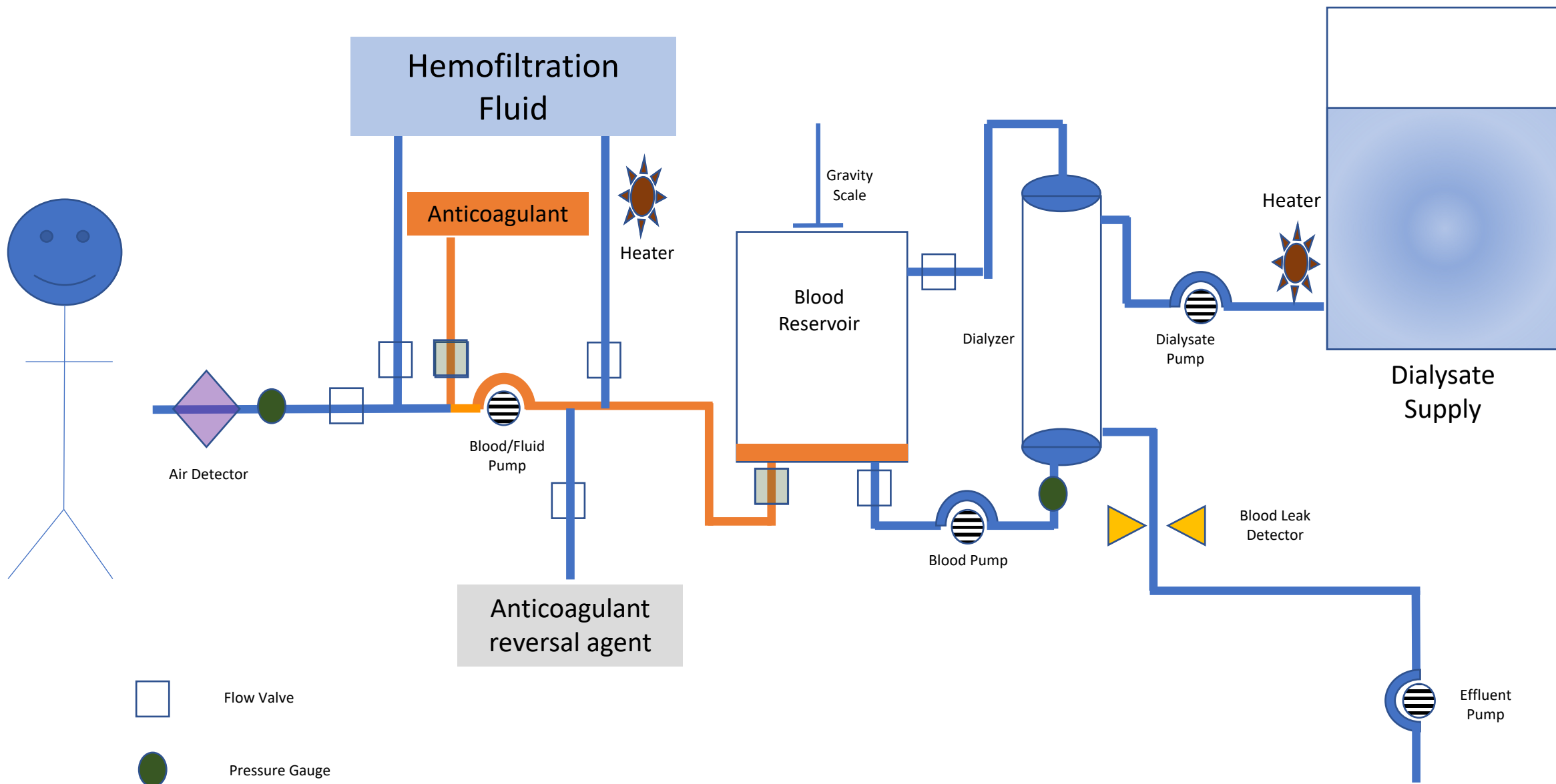

# SLAMB-HDF

## Blood Fill

Figure S1d

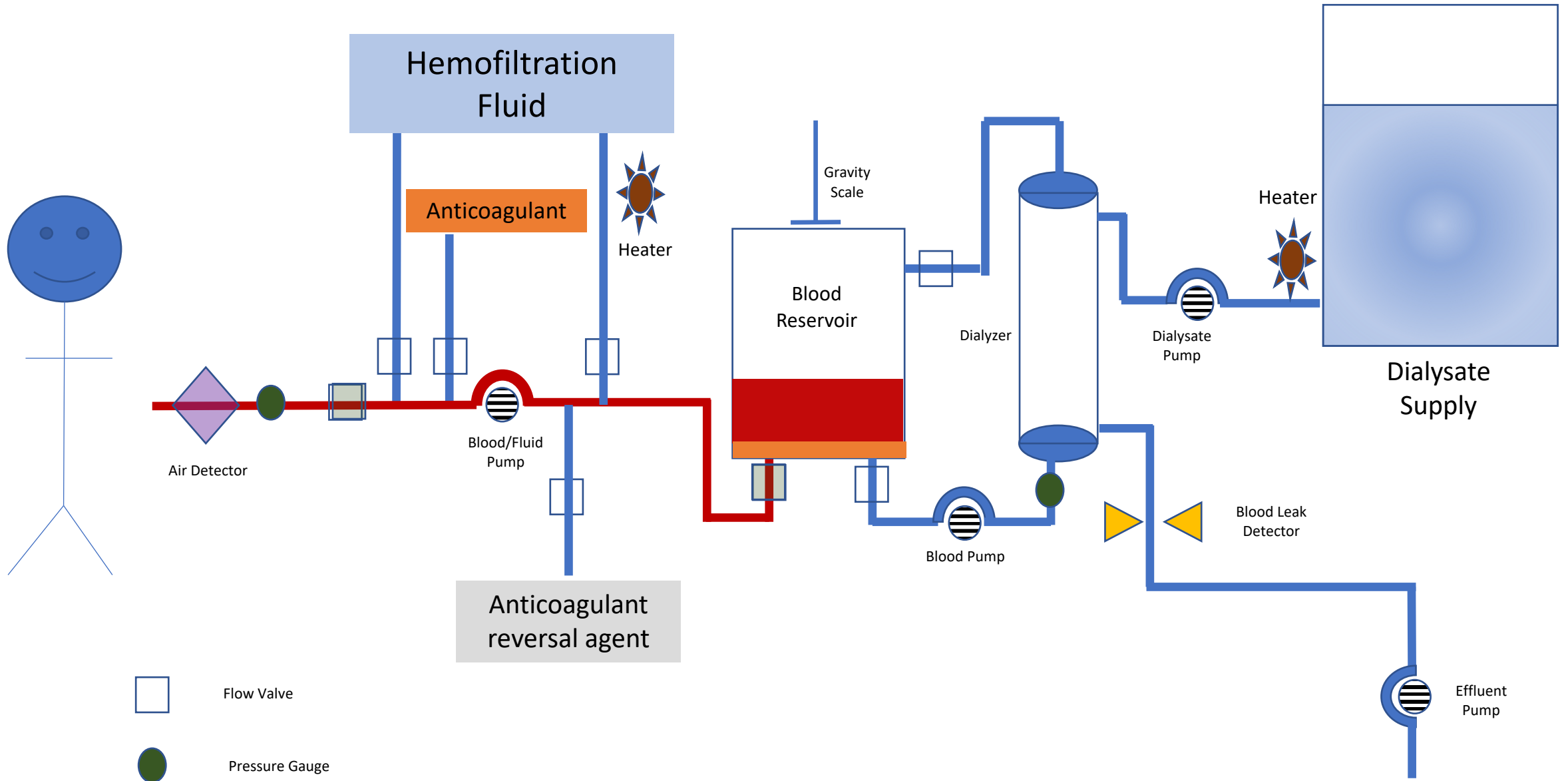

# SLAMB-HDF

## Fluid Fill

Figure S1c

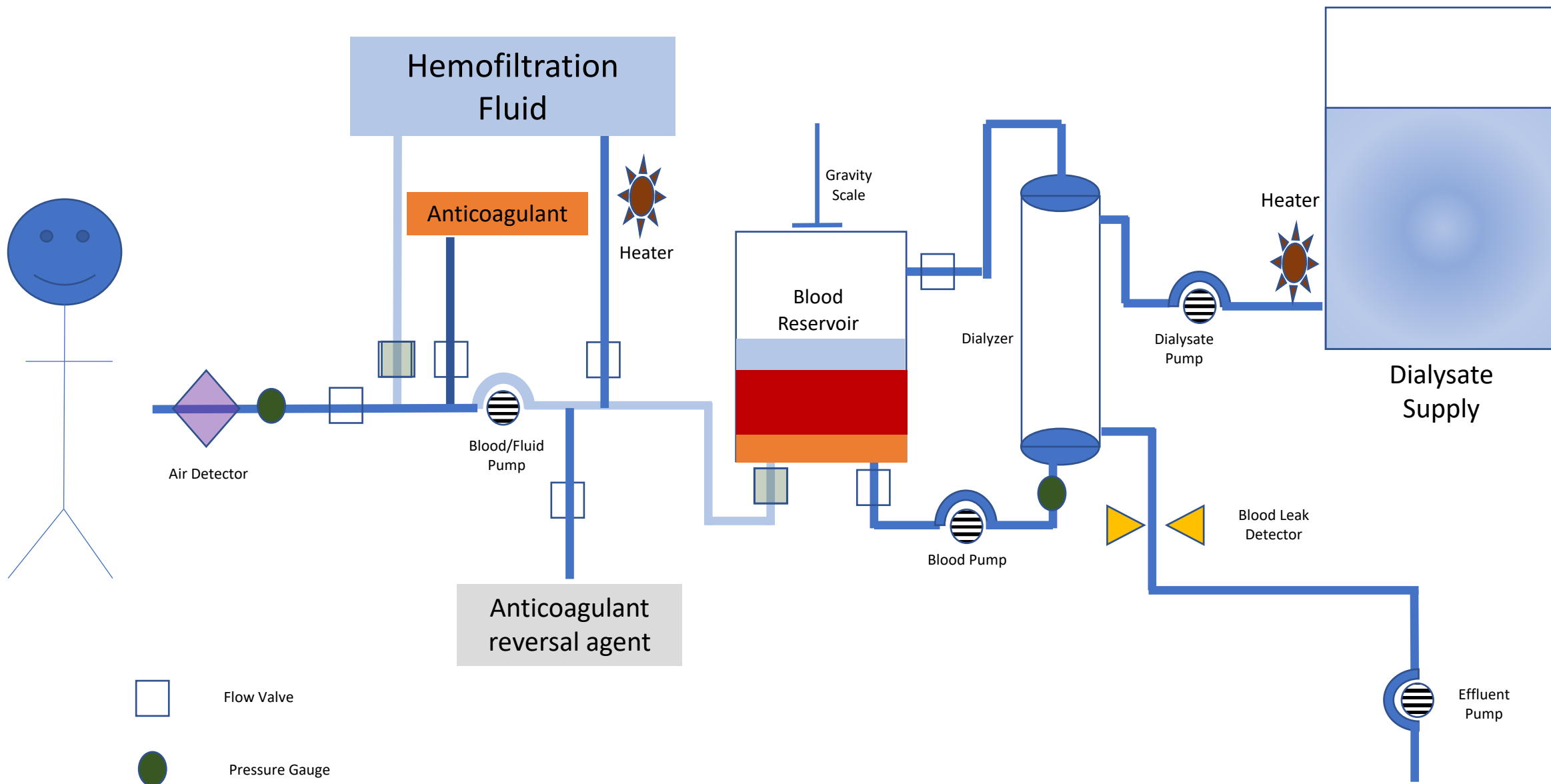

# SLAMB-HDF

## Back-flush of Line

Figure S1c

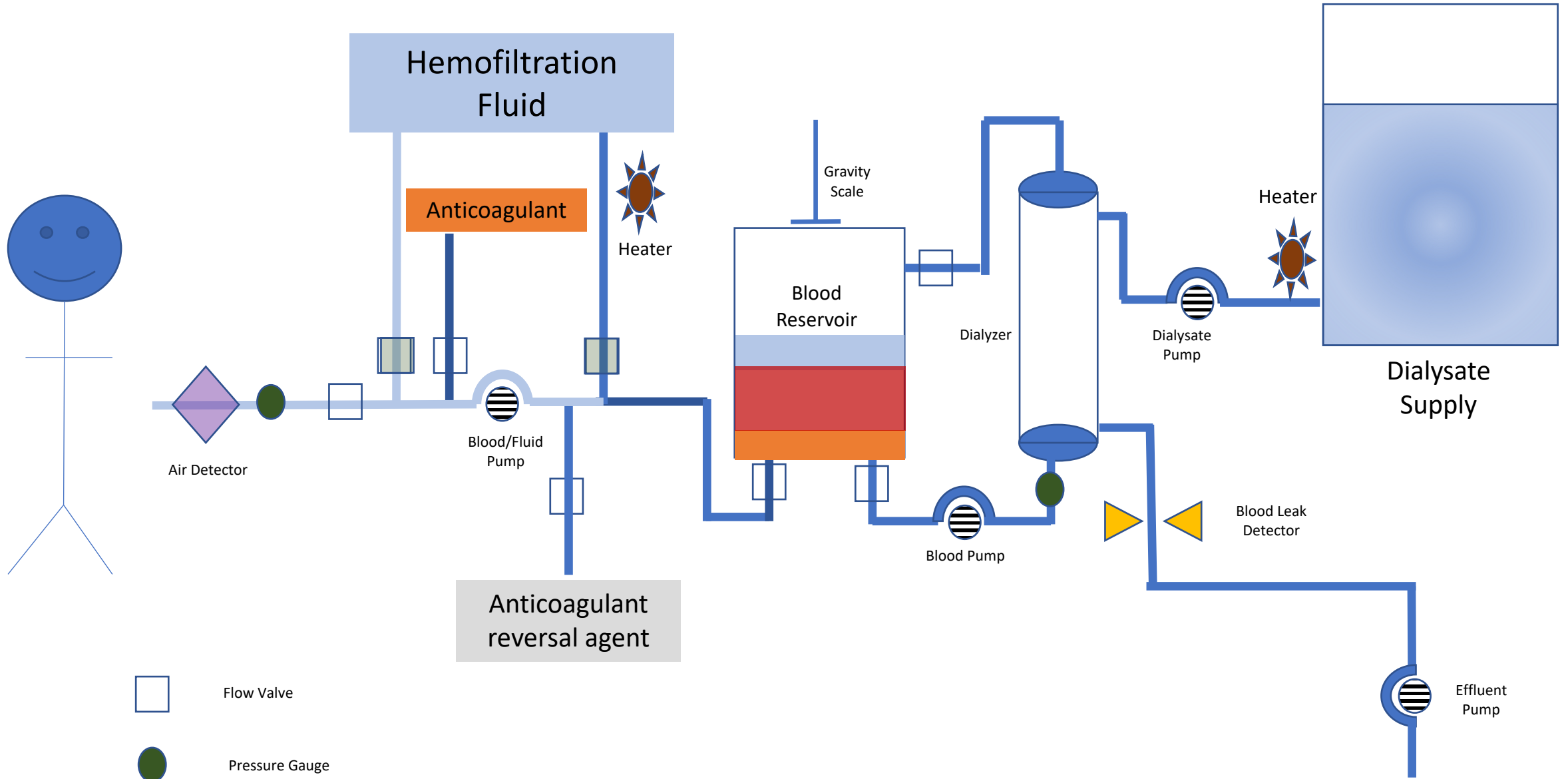

# SLAMB-HDF

## HDF Start

Figure S1d

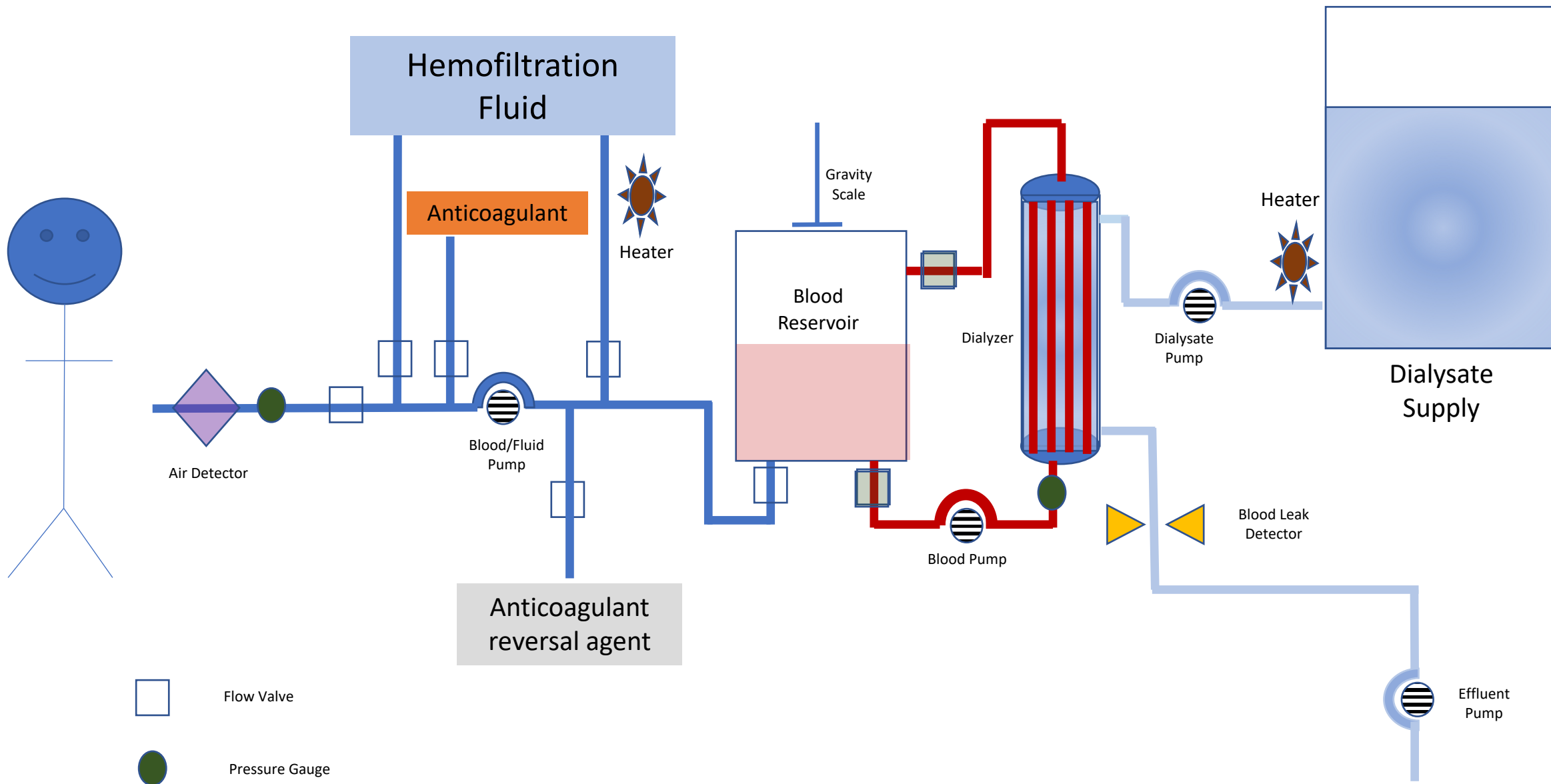



# SLAMB-HDF

## HDF

Figure S1e

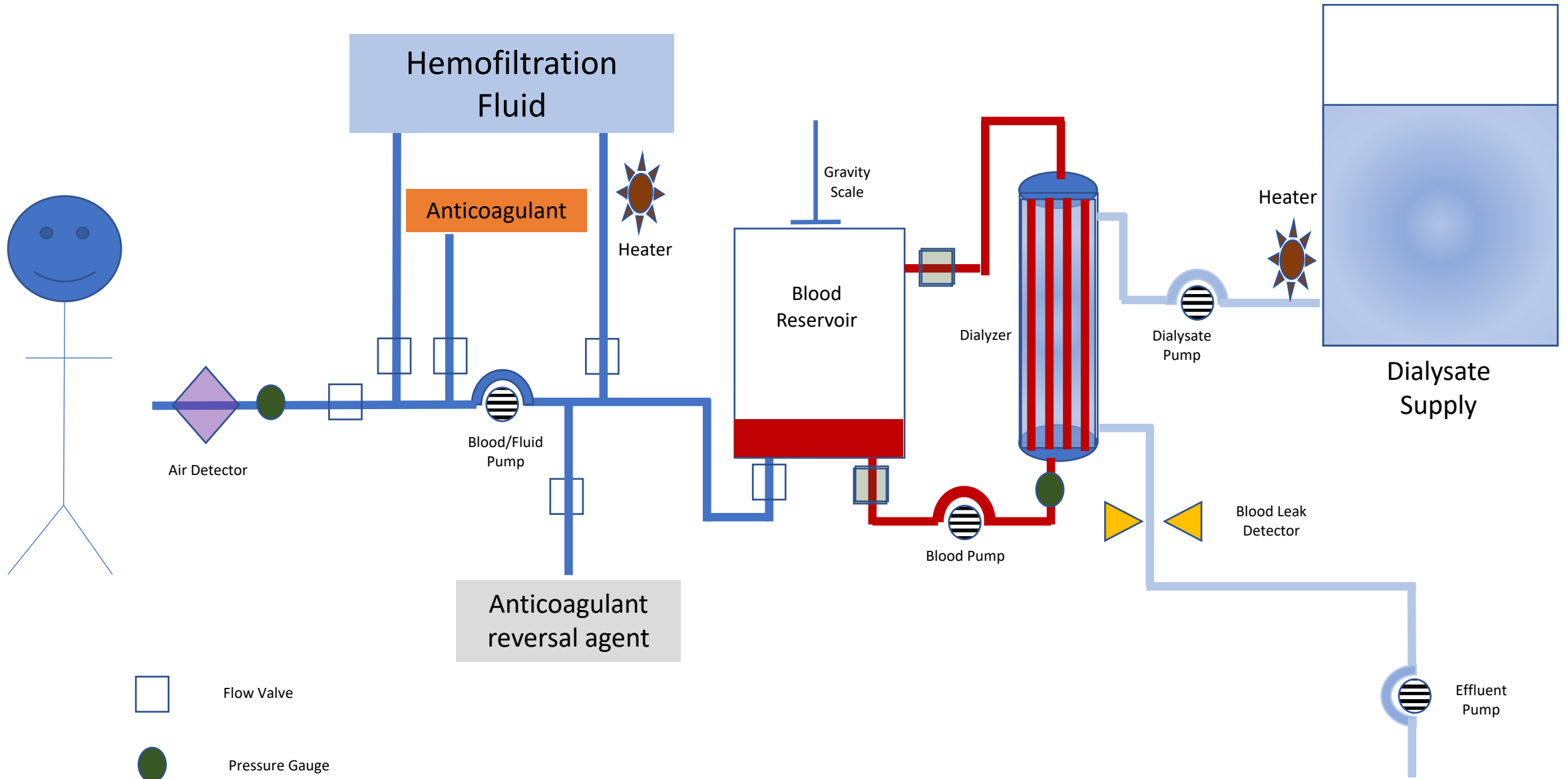

# SLAMB-HDF

## HDF End

Figure S1f

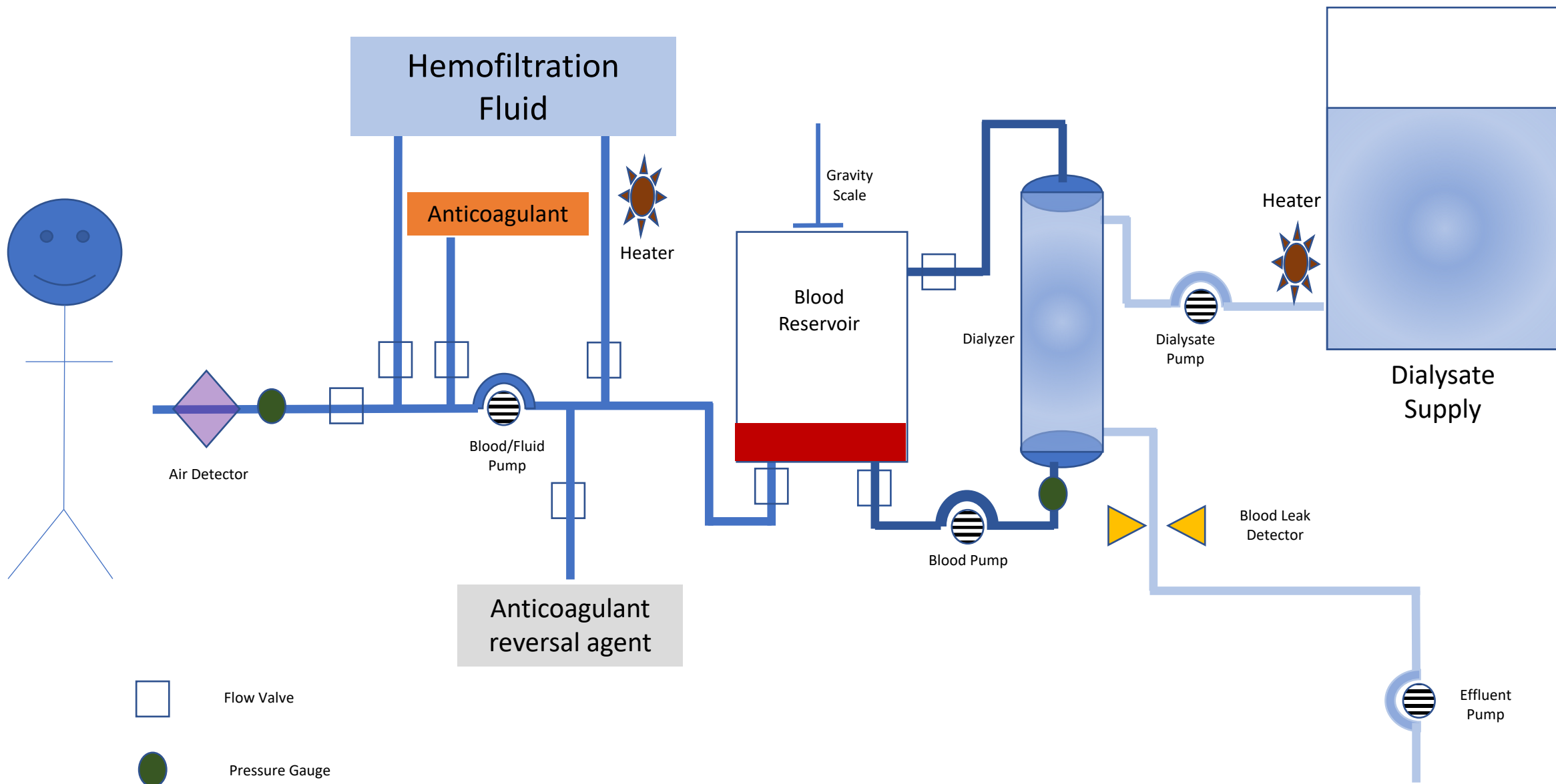

# SLAMB-HDF Blood Return

Figure S1g

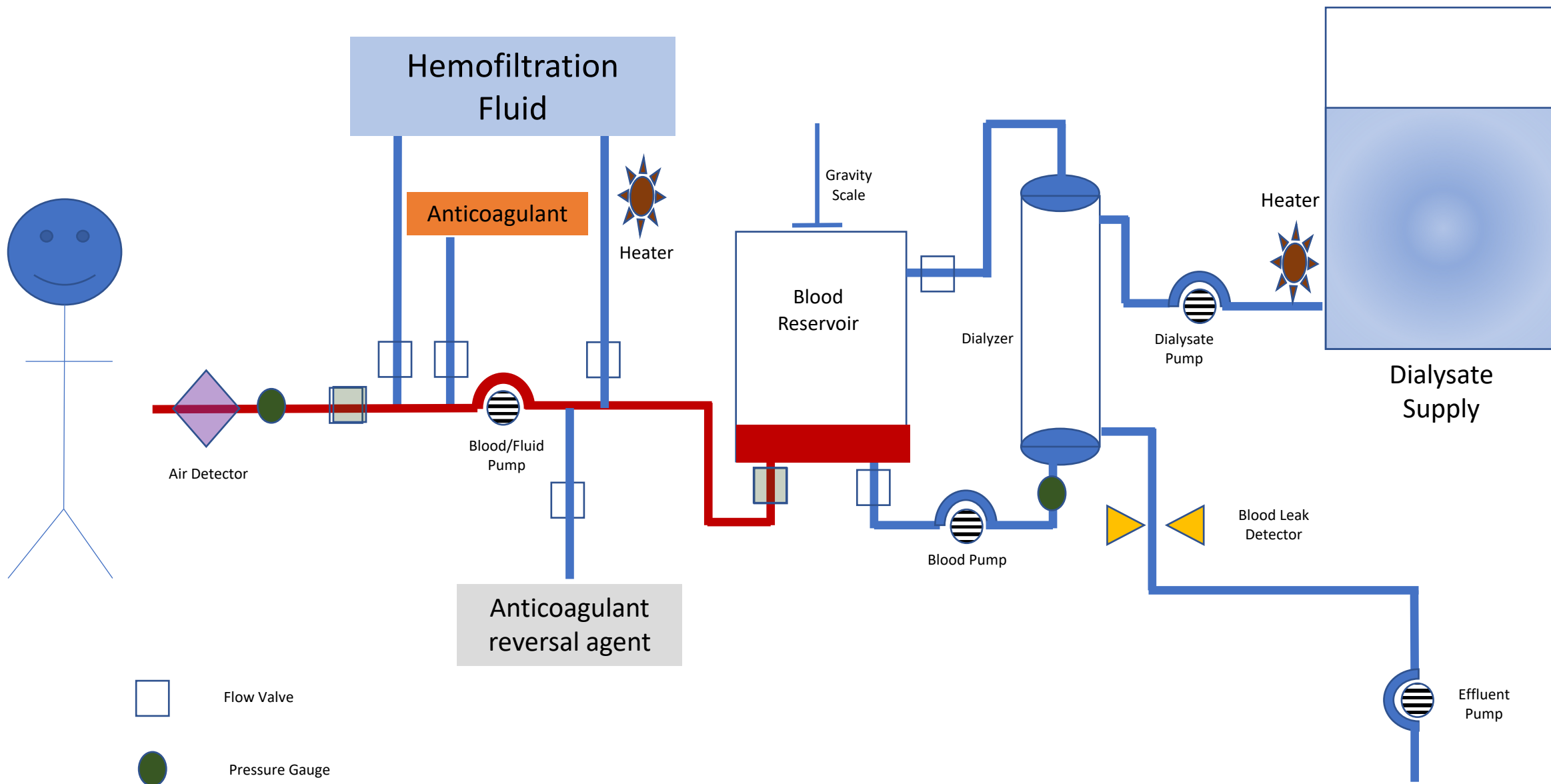



# SLAMB-HDF Flush

Figure S1i

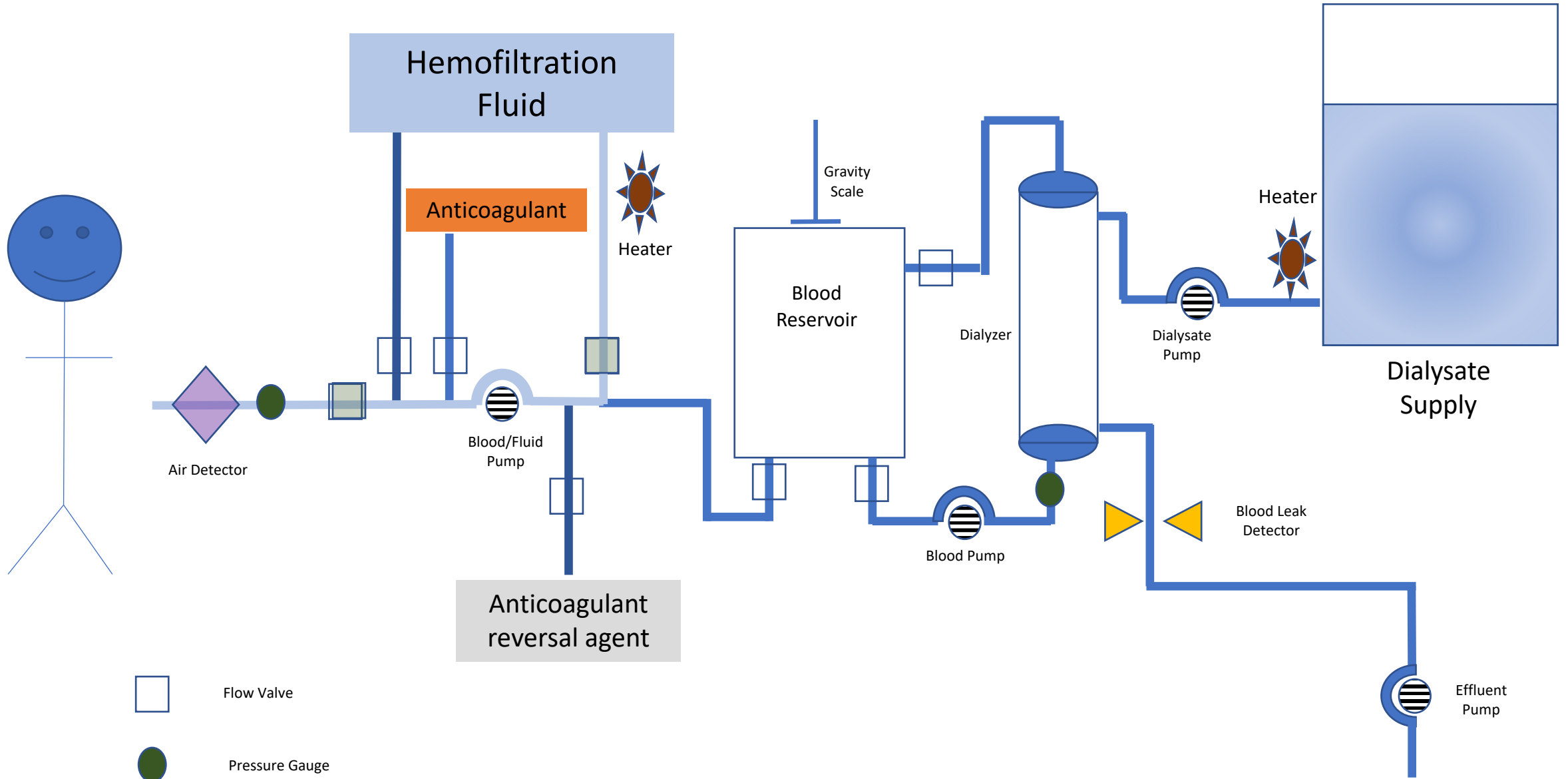

# SLAMB-HDF Back Flush

Figure S1j

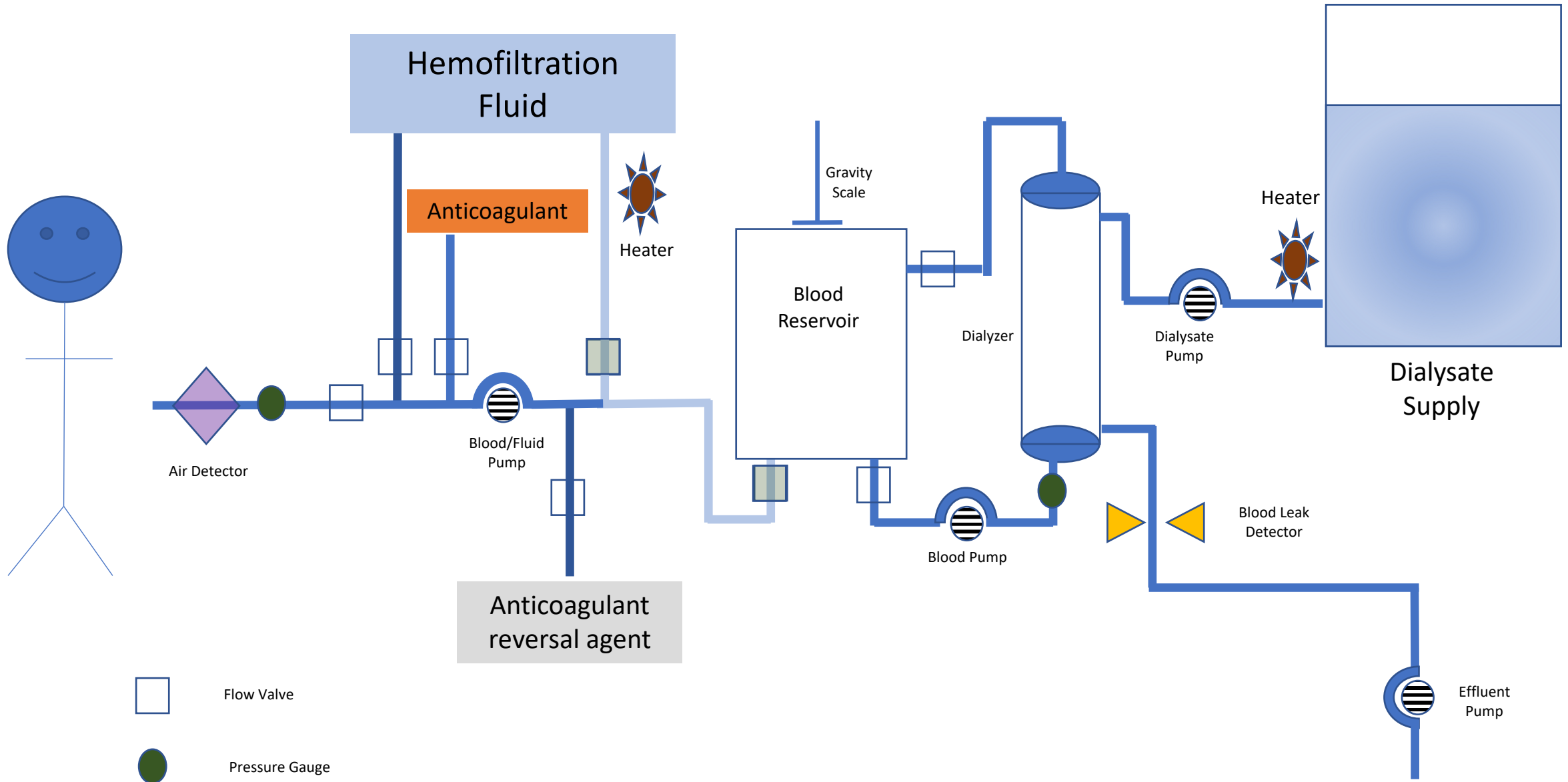

# SLAMB-HF Start

Figure S2a

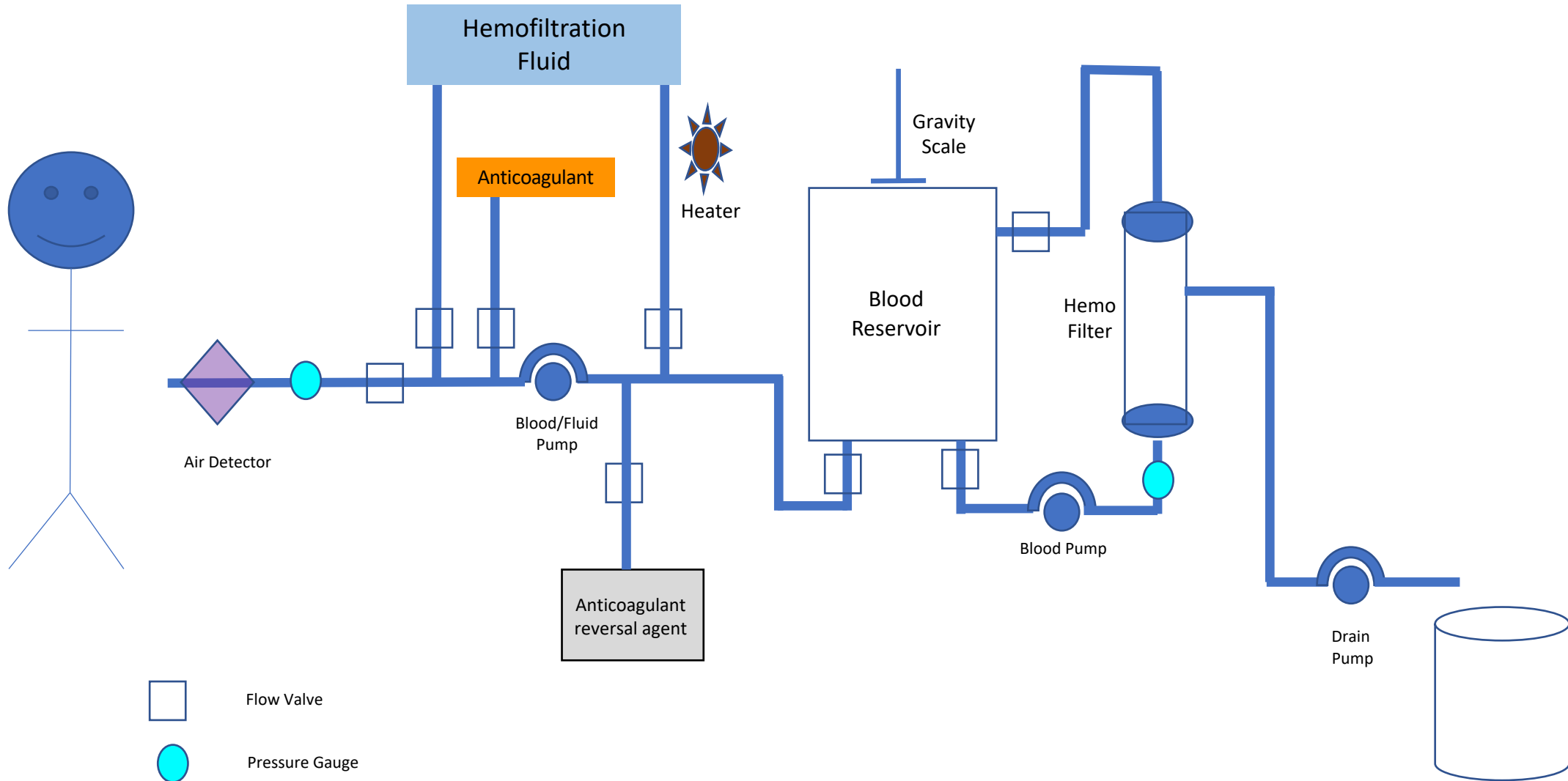



# SLAMB-HF

Figure S2b

## Anticoagulation Fill

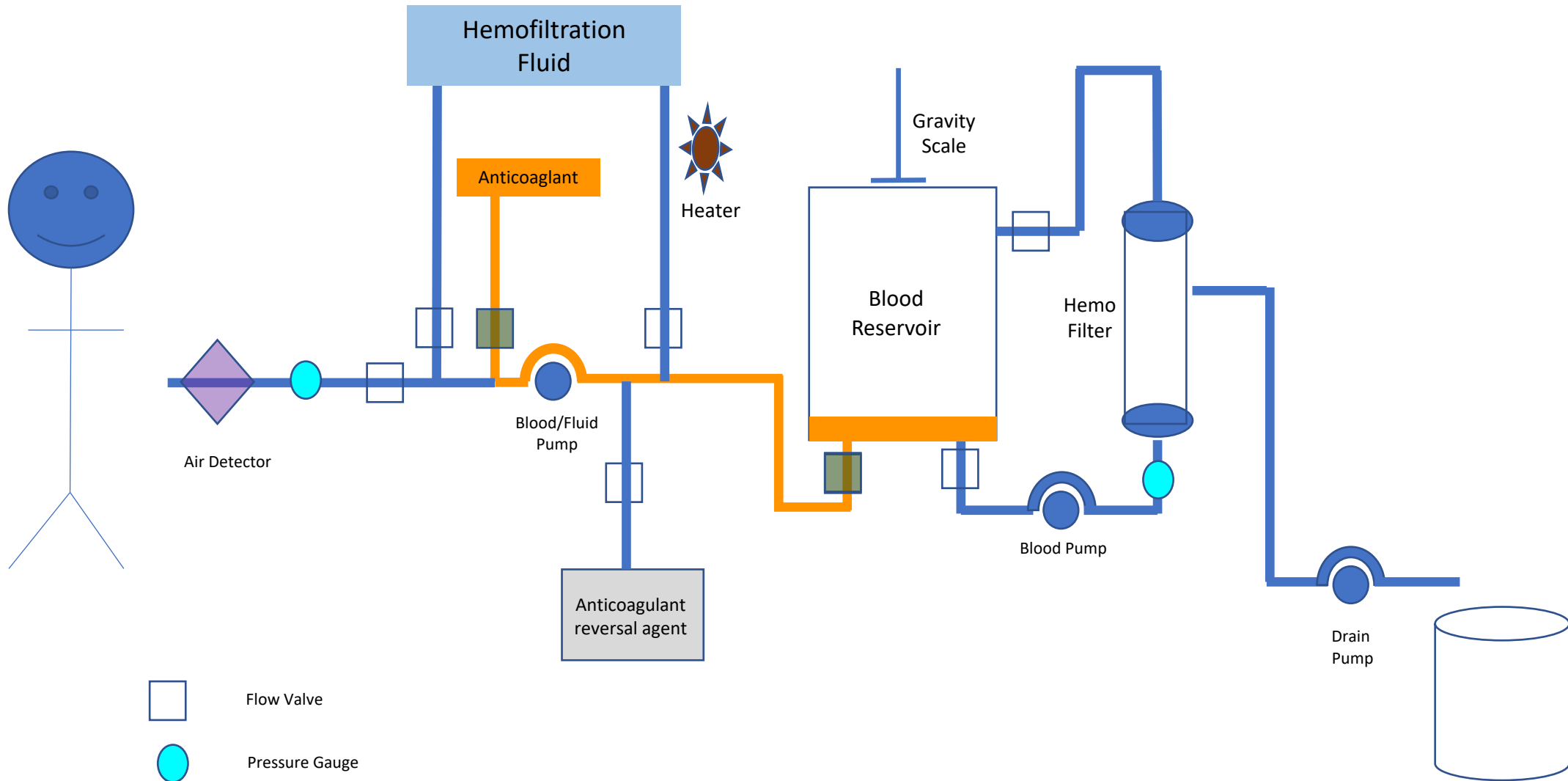



# SLAMB-HF Blood Fill from Patient

Figure S2d

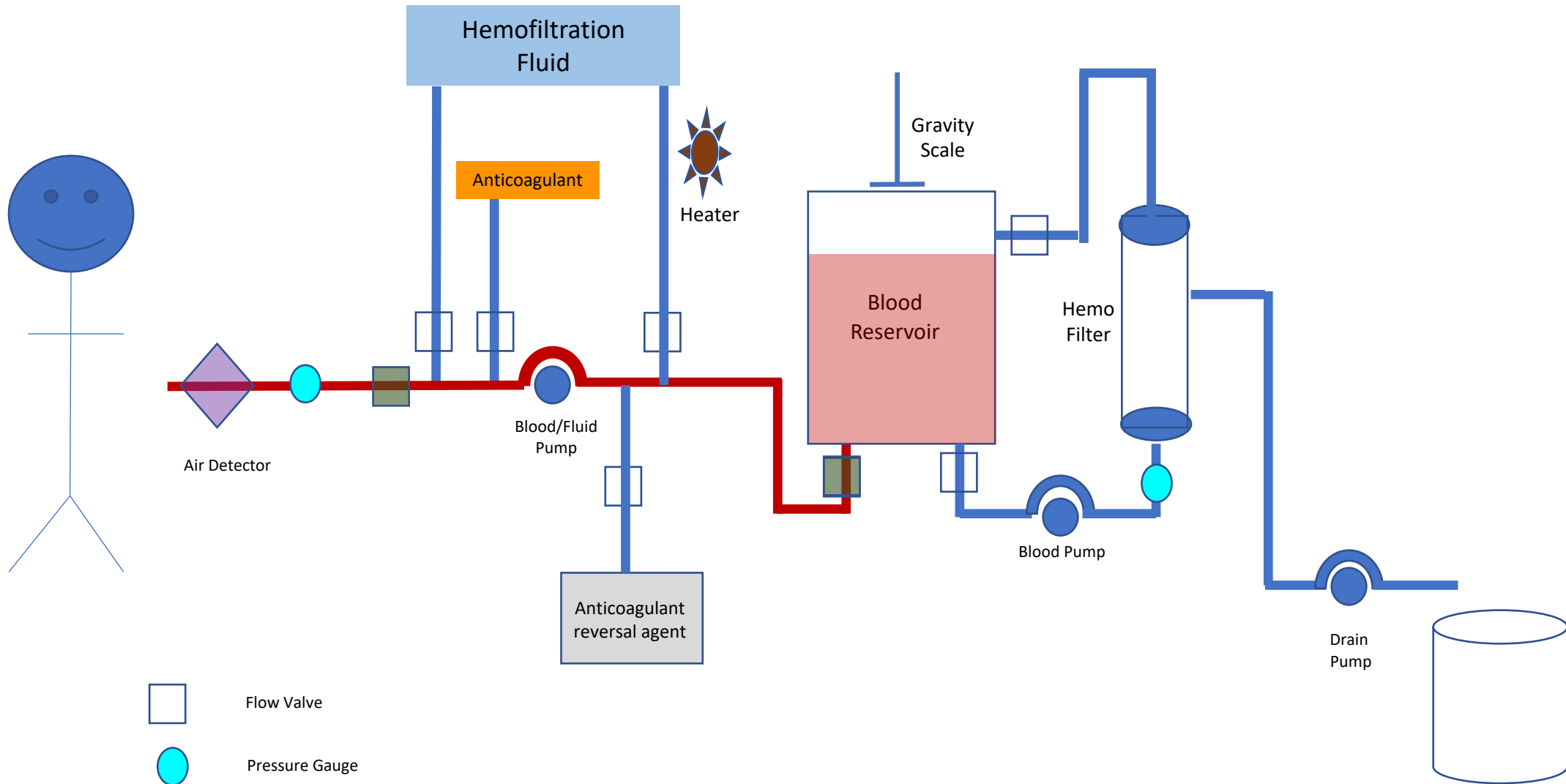

# SLAMB-HF

Figure S2e

## Start Hemofiltration

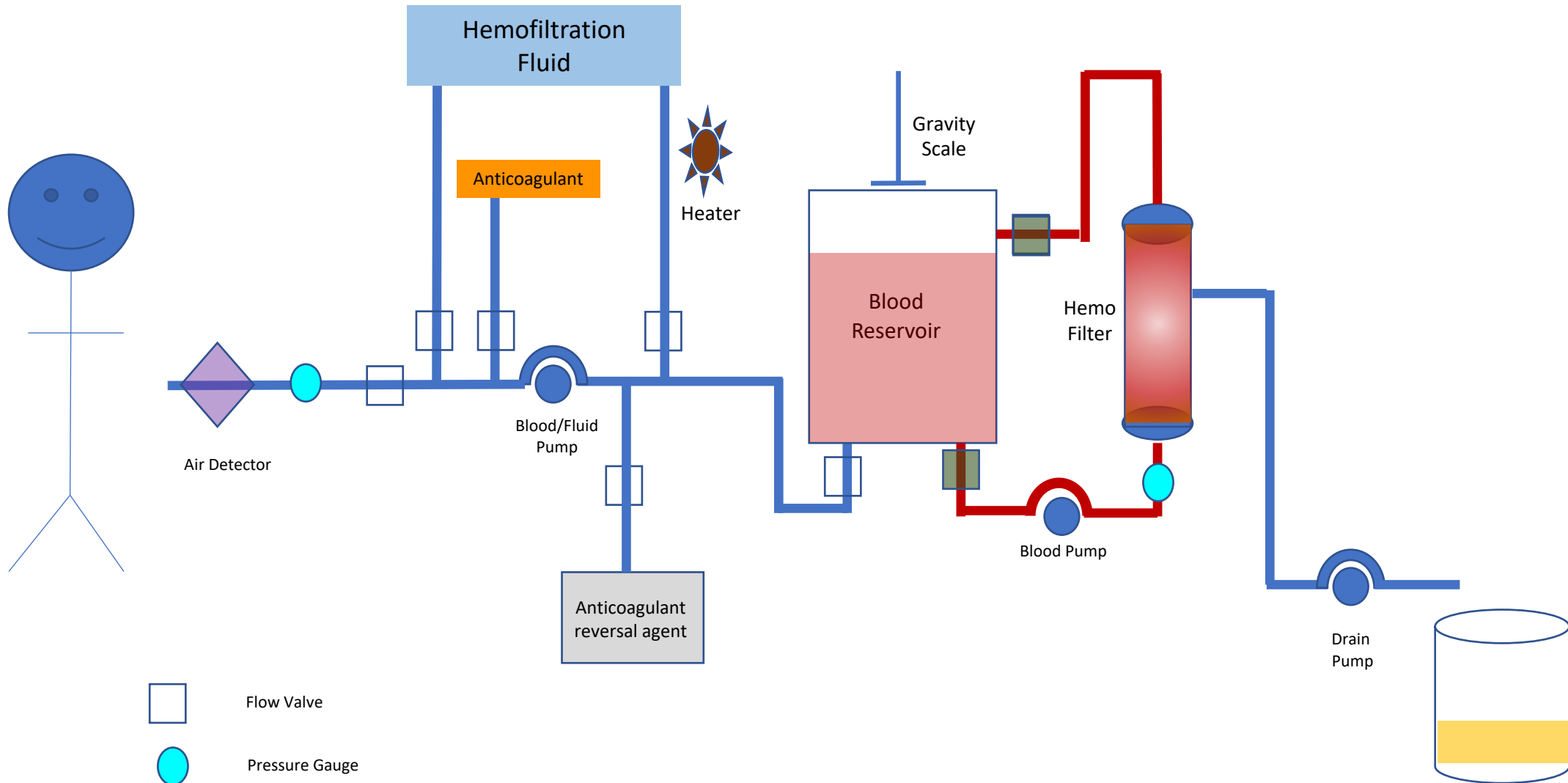

# SLAMB-HF Batch Processed

Figure S2f

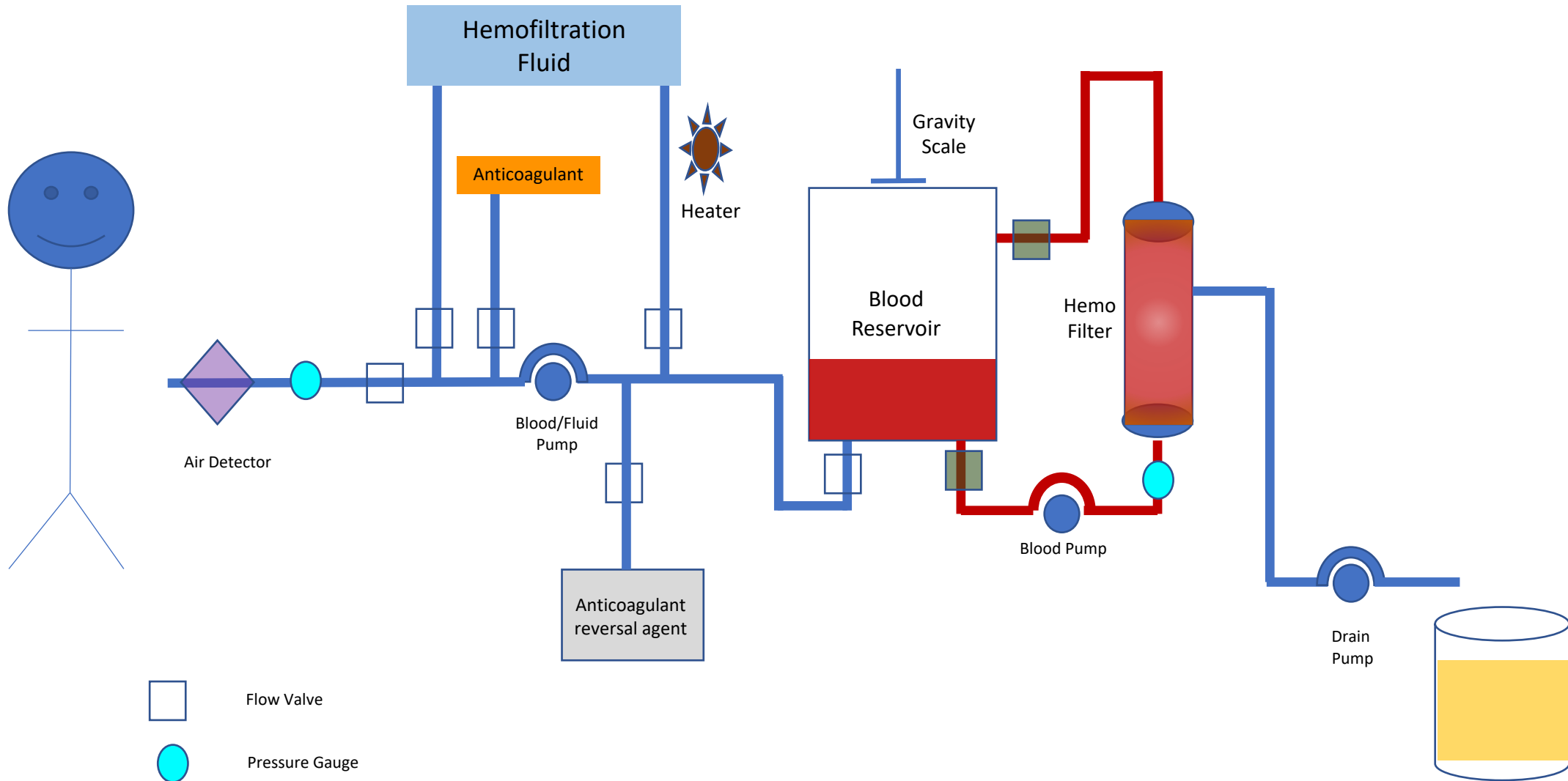

# SLAMB-HF Blood Return

Figure S2g

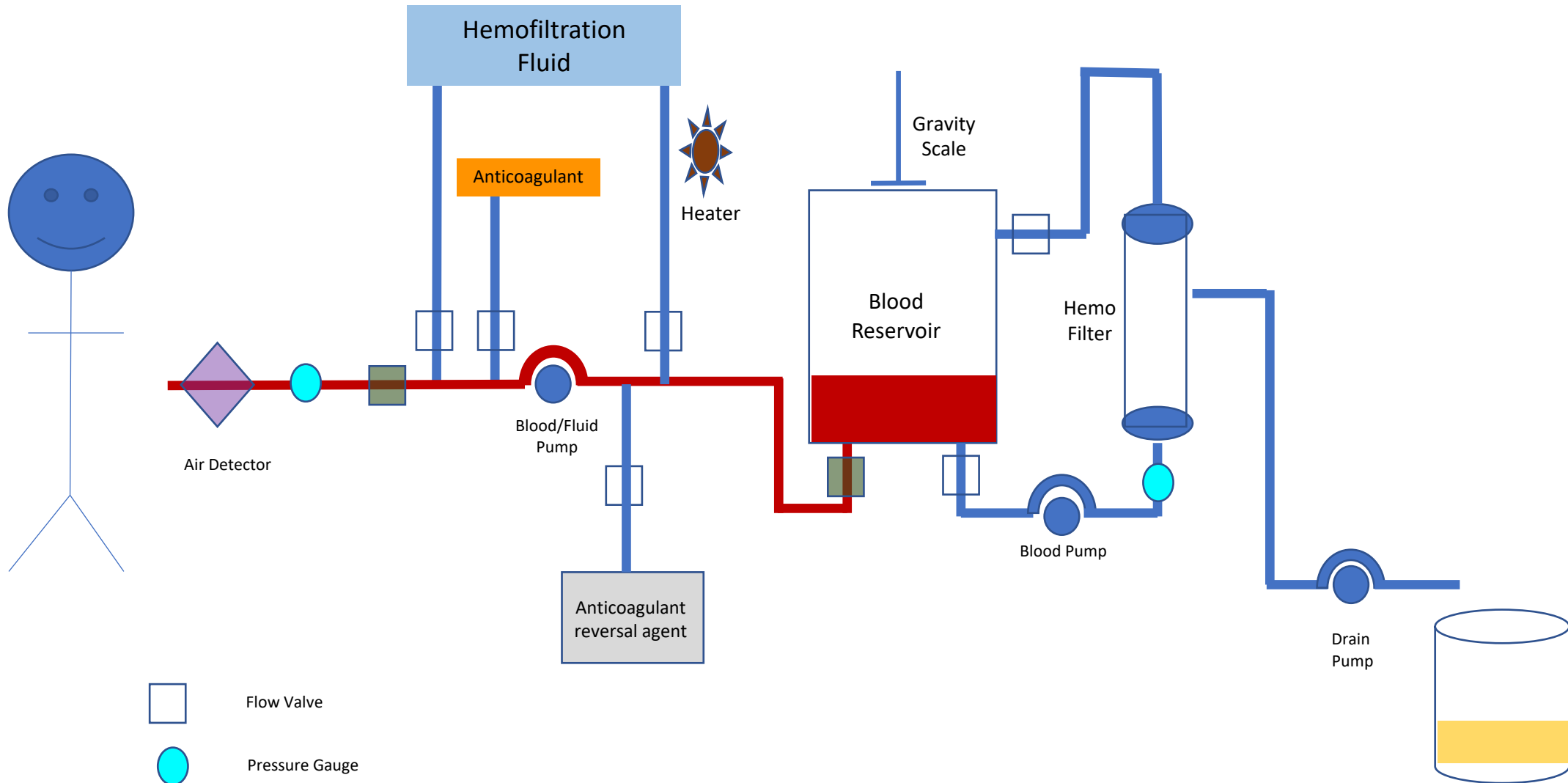

# SLAMB-HF

Figure S2h

## Reversal Agent Dosed

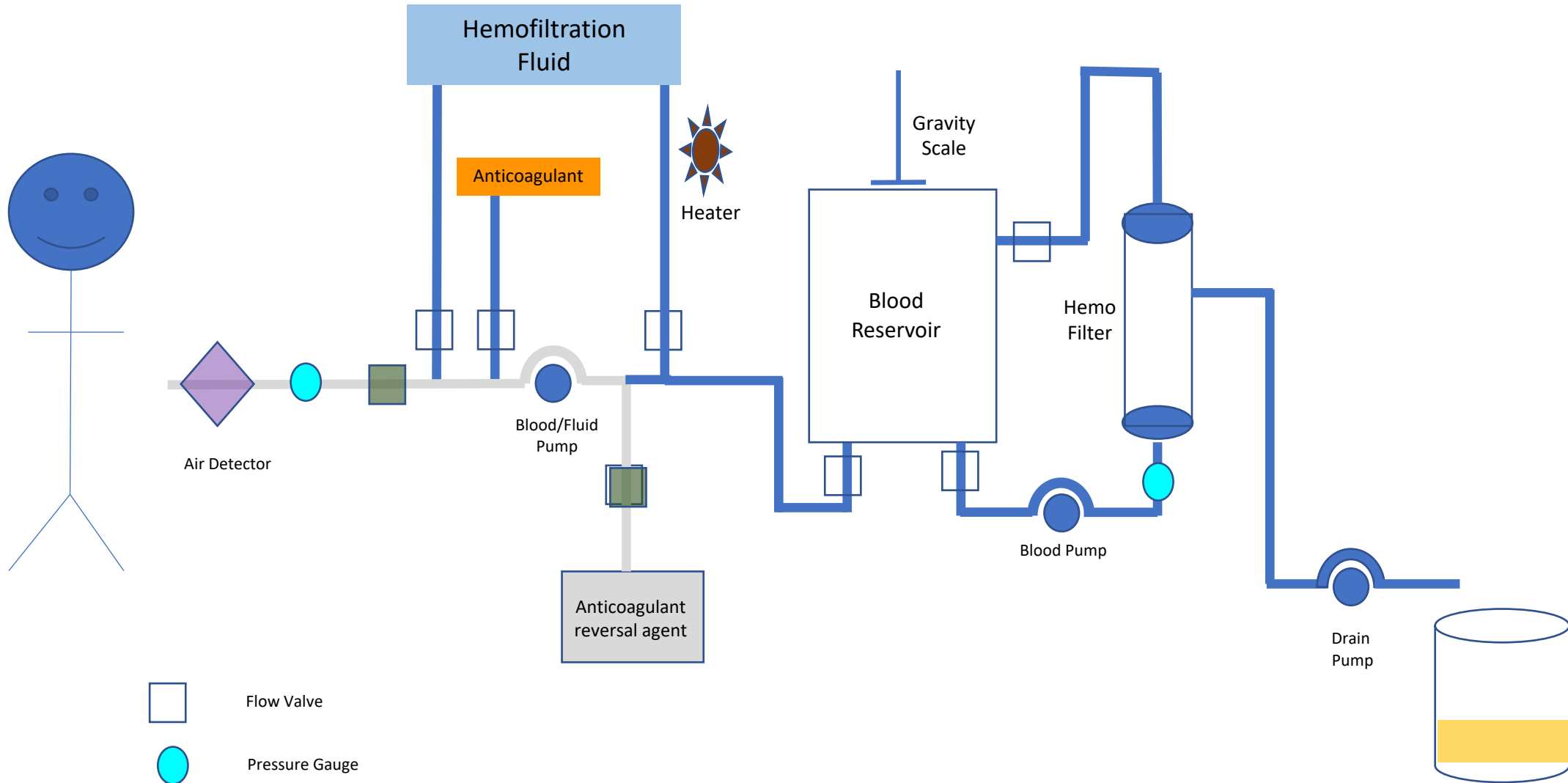



# SLAMB-HF Lines Flushed

Figure S2i

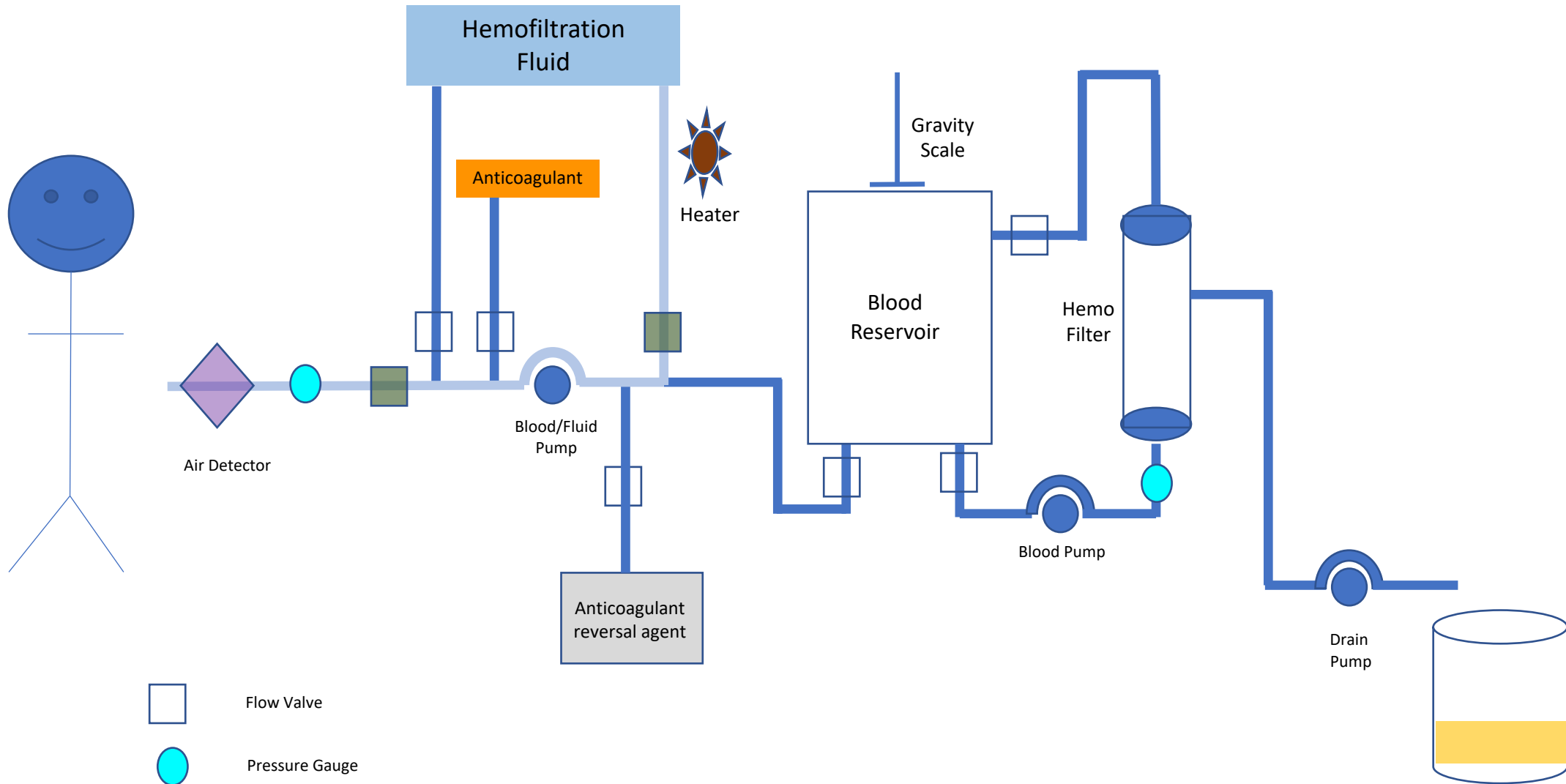

# SLAMB-HD

Figure S3a

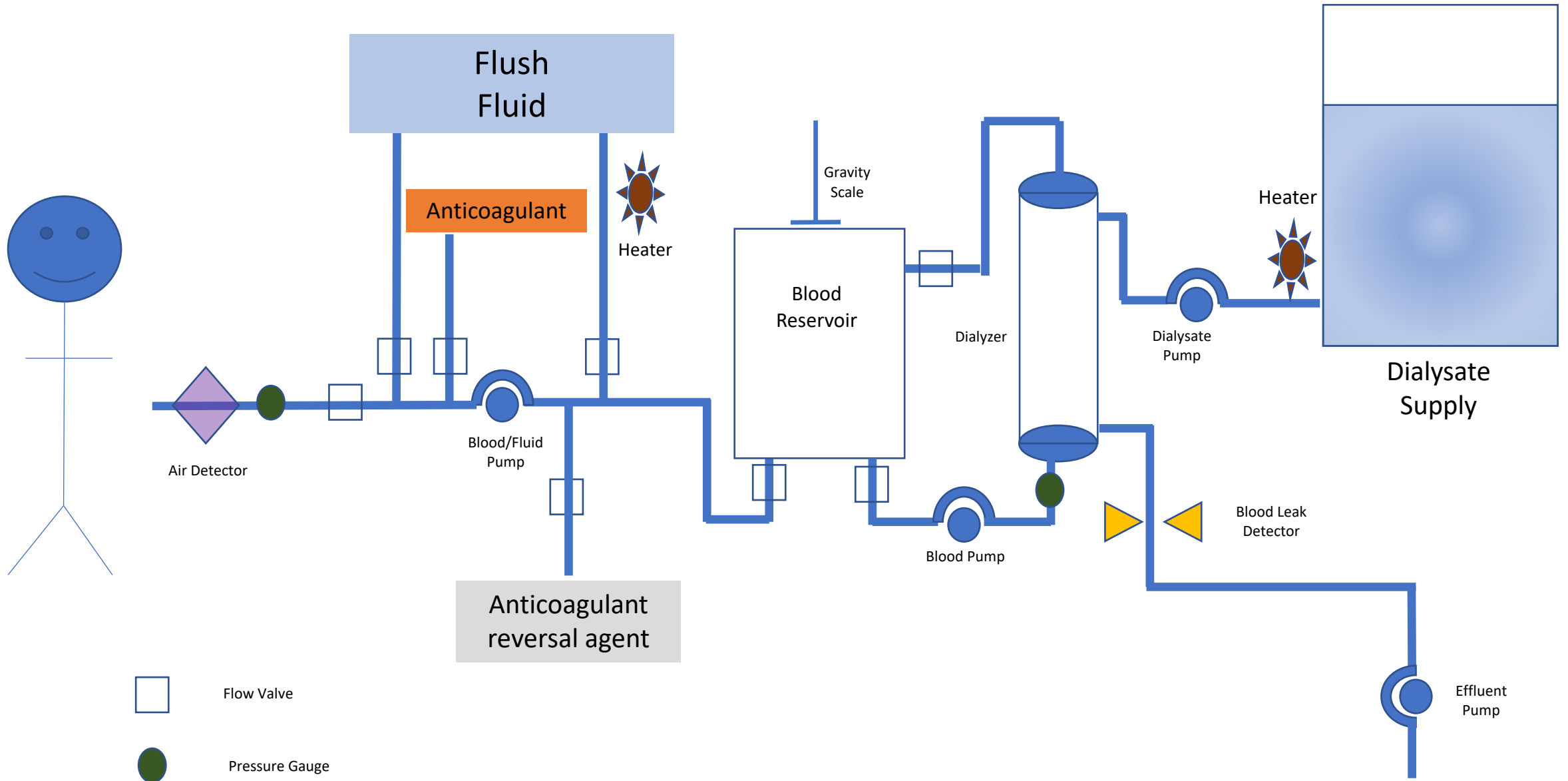

# SLAMB-HD

## Anticoagulant Fill

Figure S3b

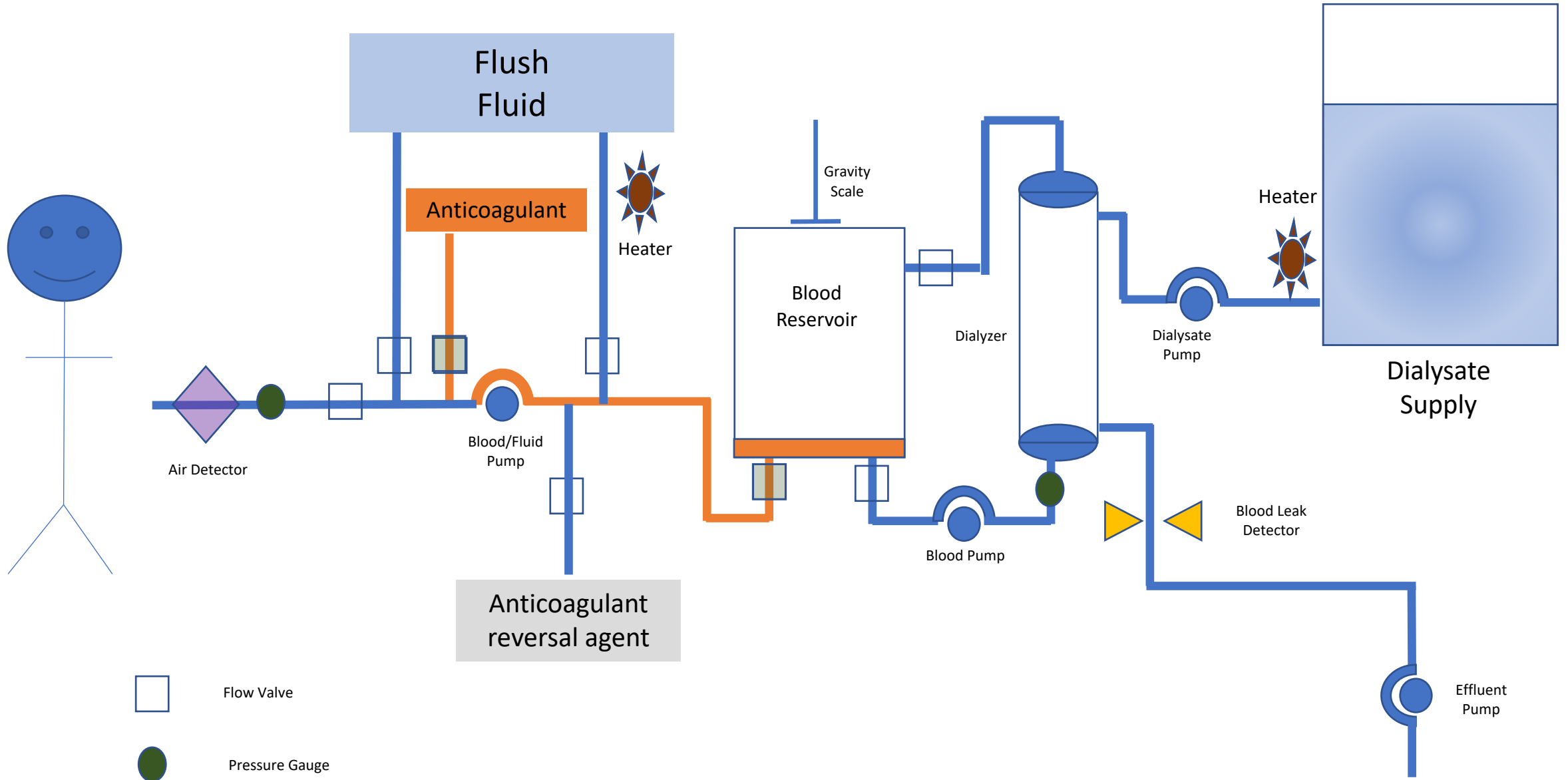

# SLAMB-HD

## Blood Fill

Figure S3c

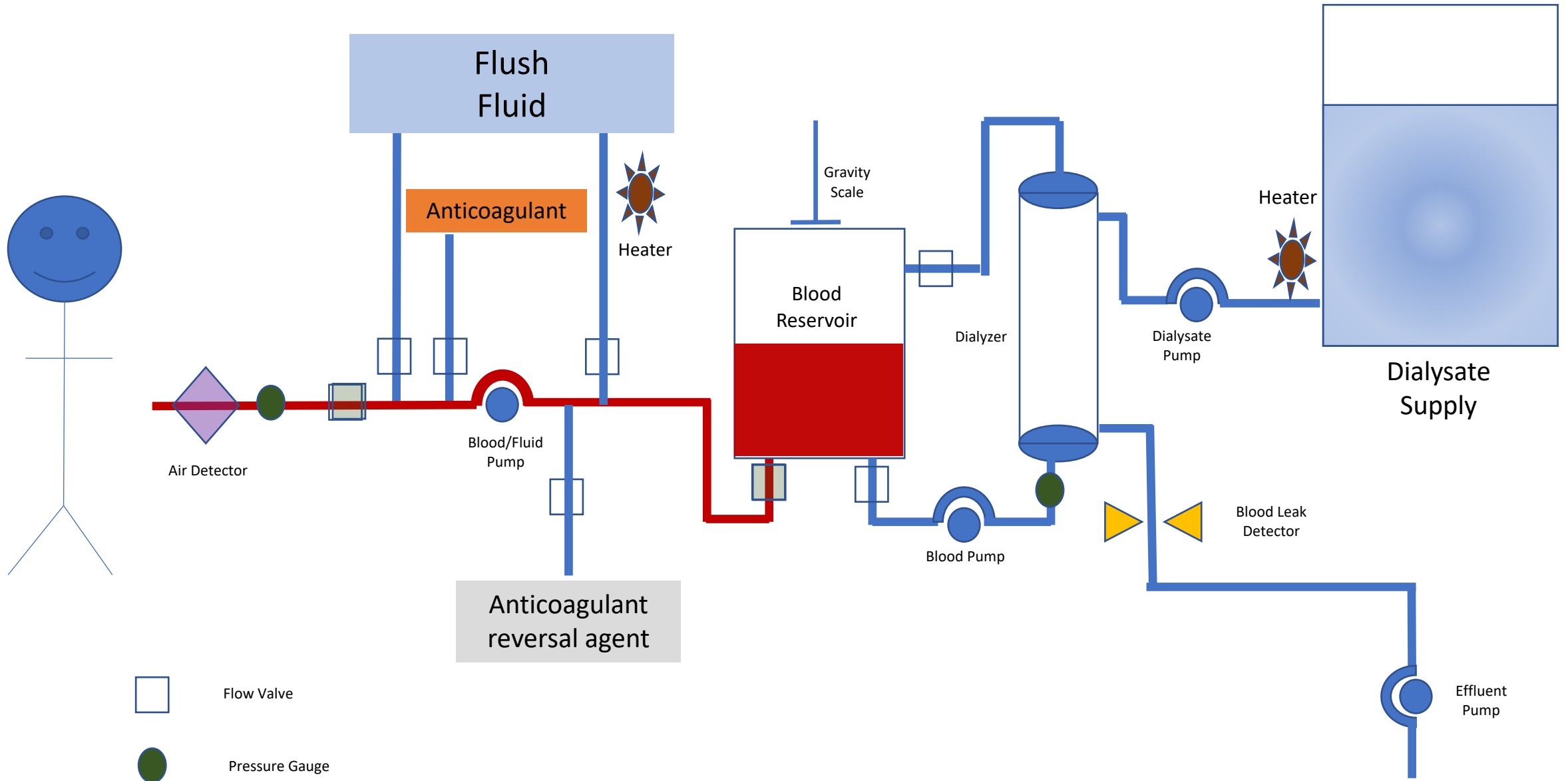

# SLAMB-HD

## HD Start

Figure S3d

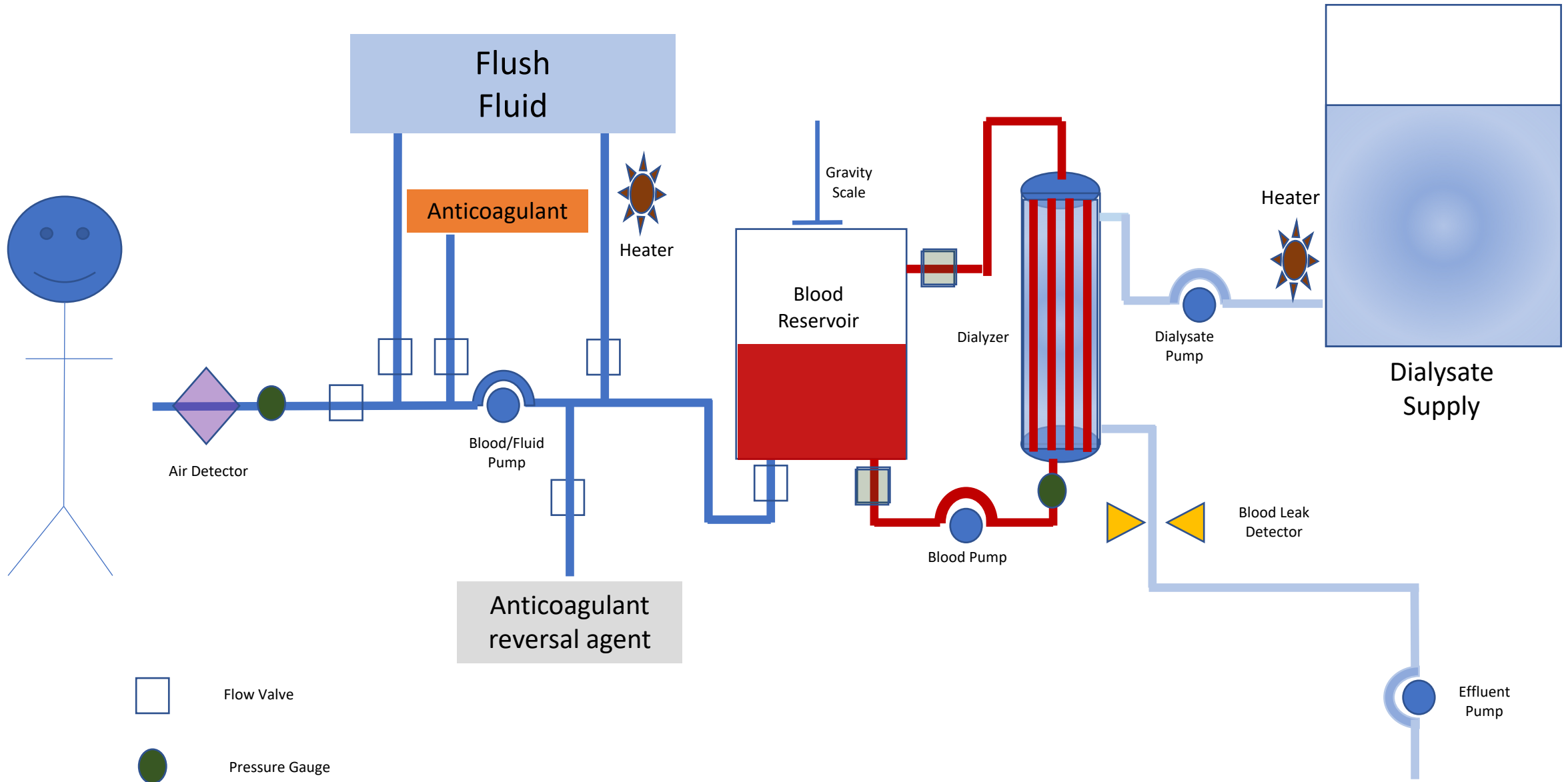

# SLAMB-HD

## HD

Figure S3e

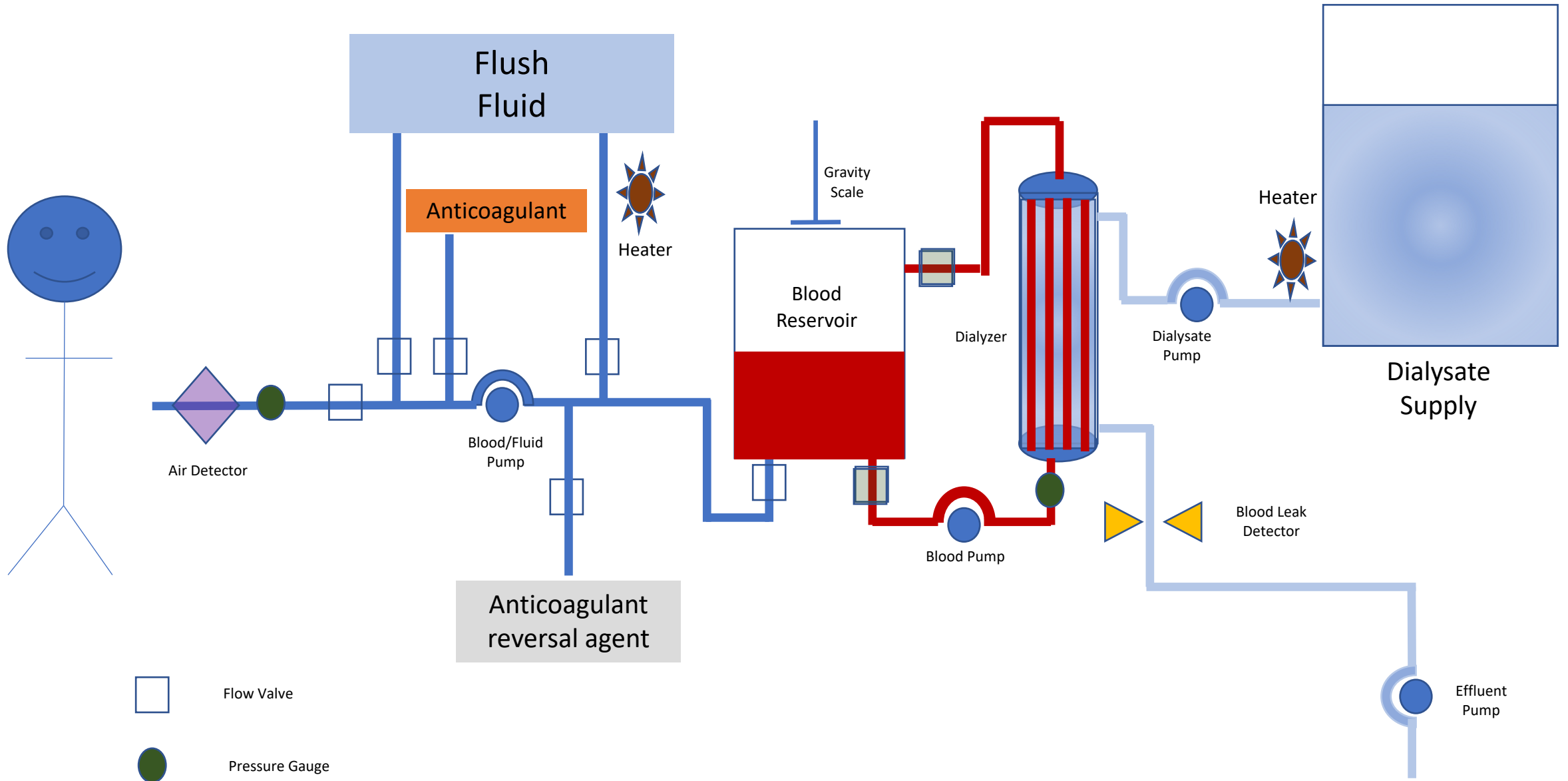

# SLAMB-HD

## HDF End

Figure S3f

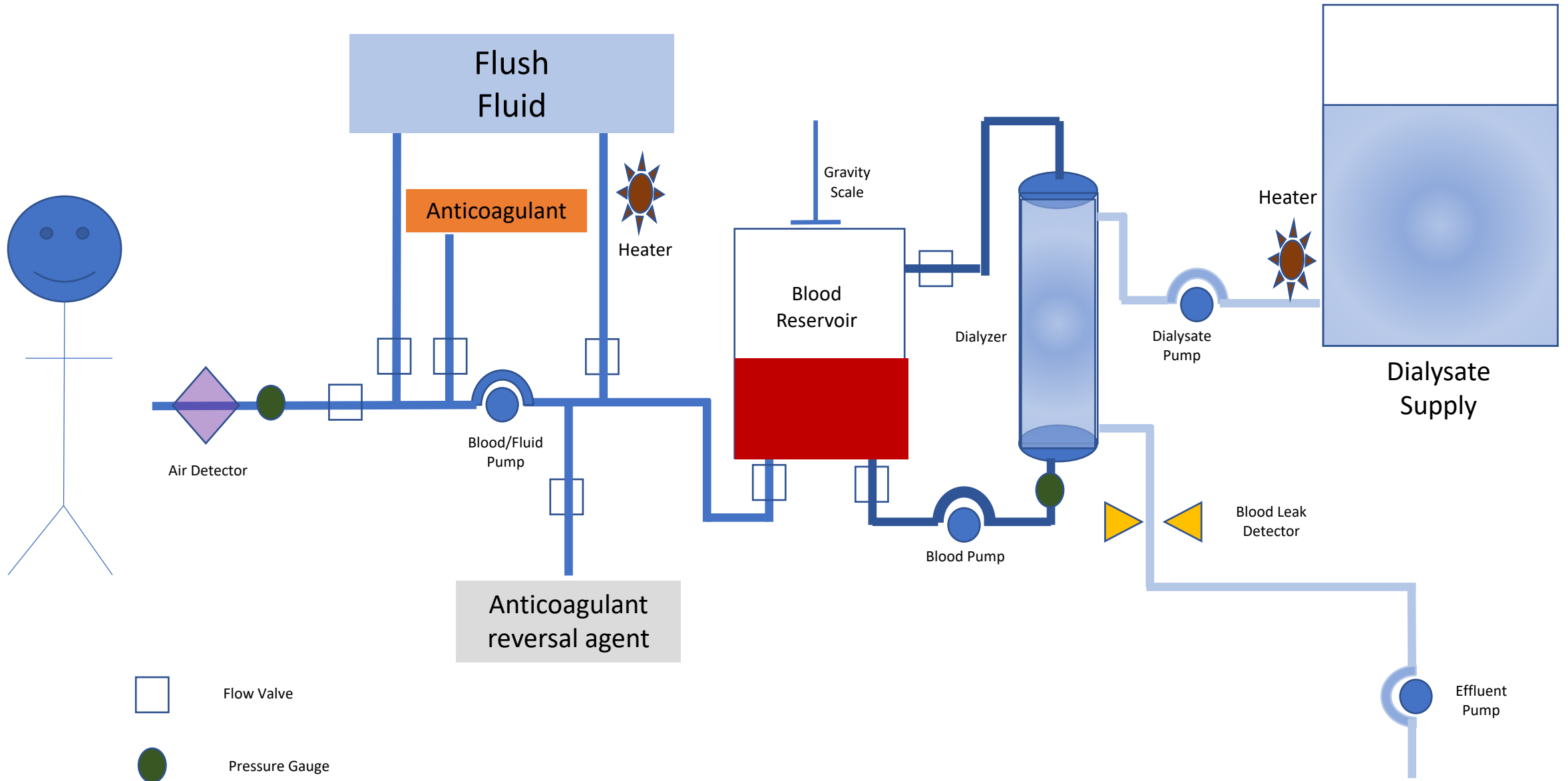

# SLAMB-HD Blood Return

Figure S3g

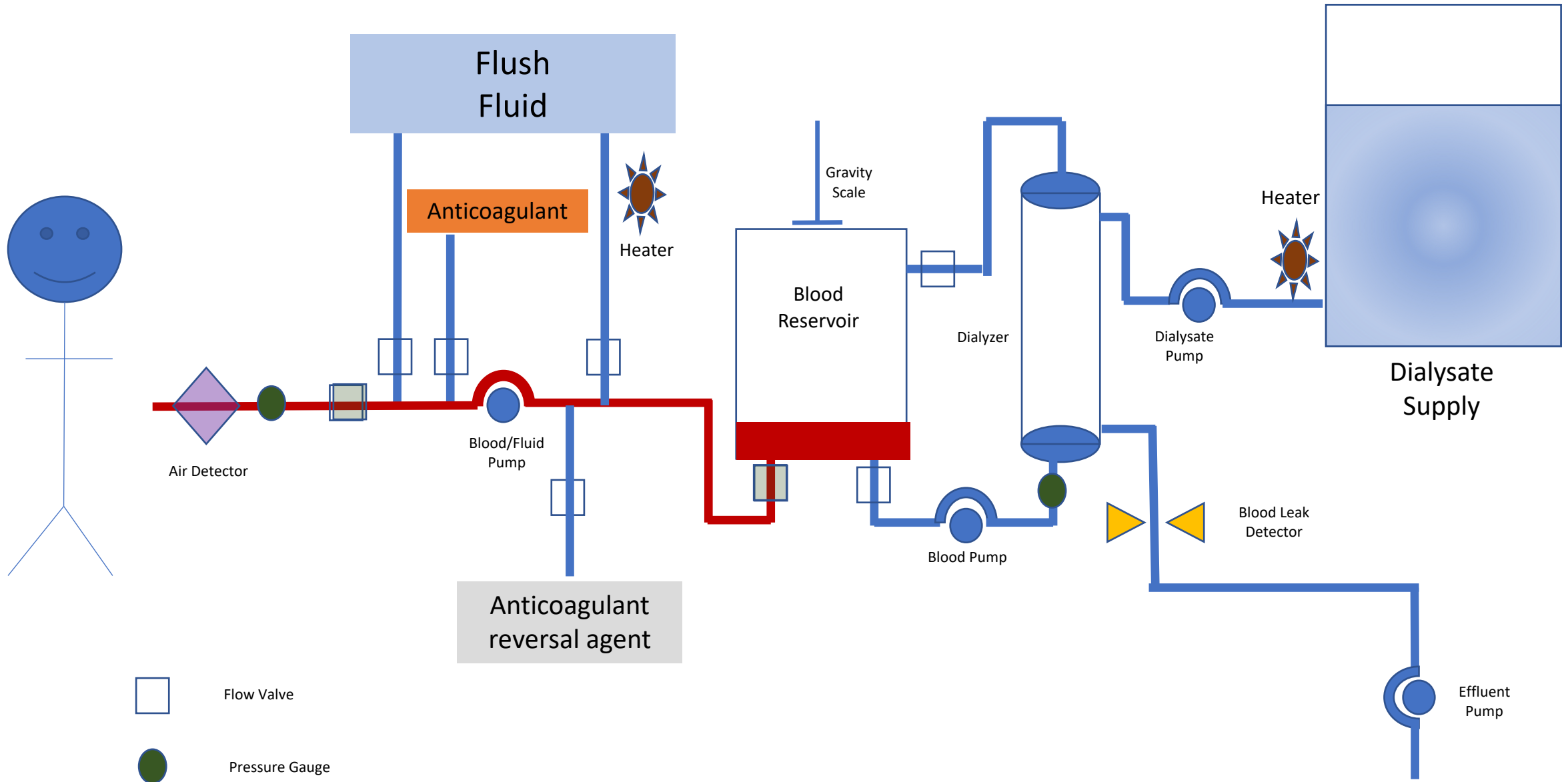



# SLAMB-HD

## Reversal Agent Given

Figure S3h

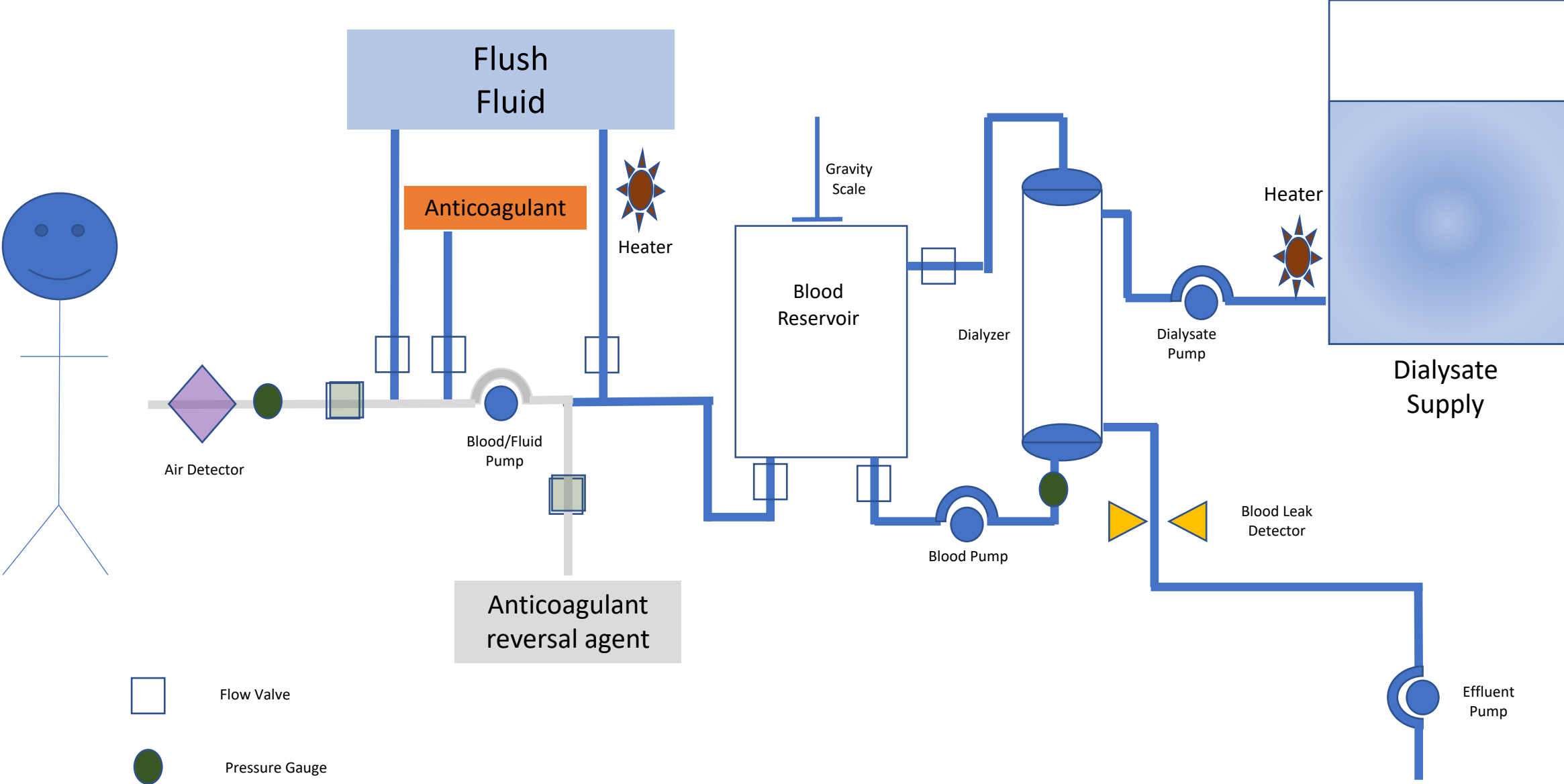

# SLAMB-HD Flush

Figure S3i

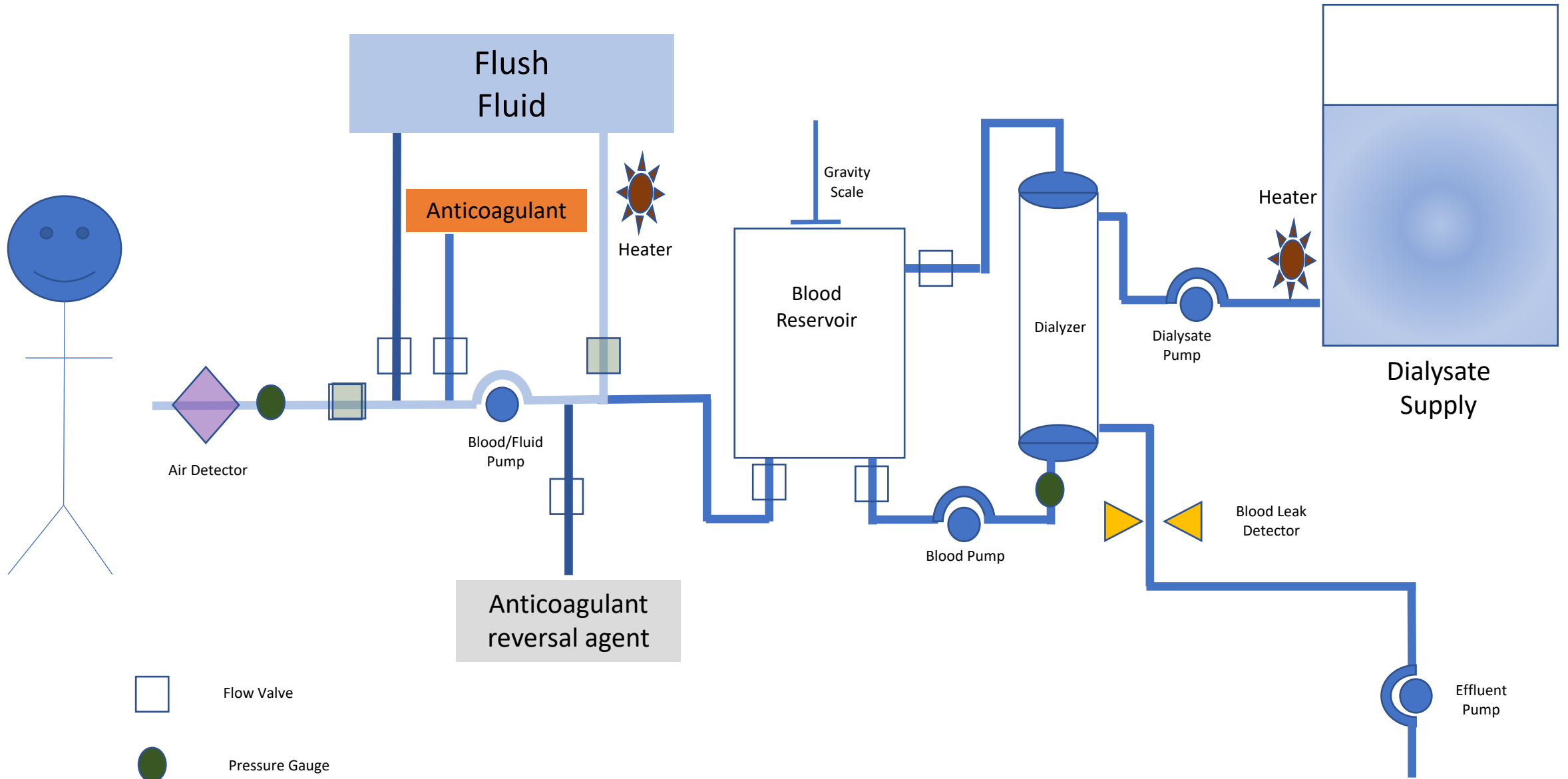

Figure S4a  
Manual Syringe SLAMB-HF

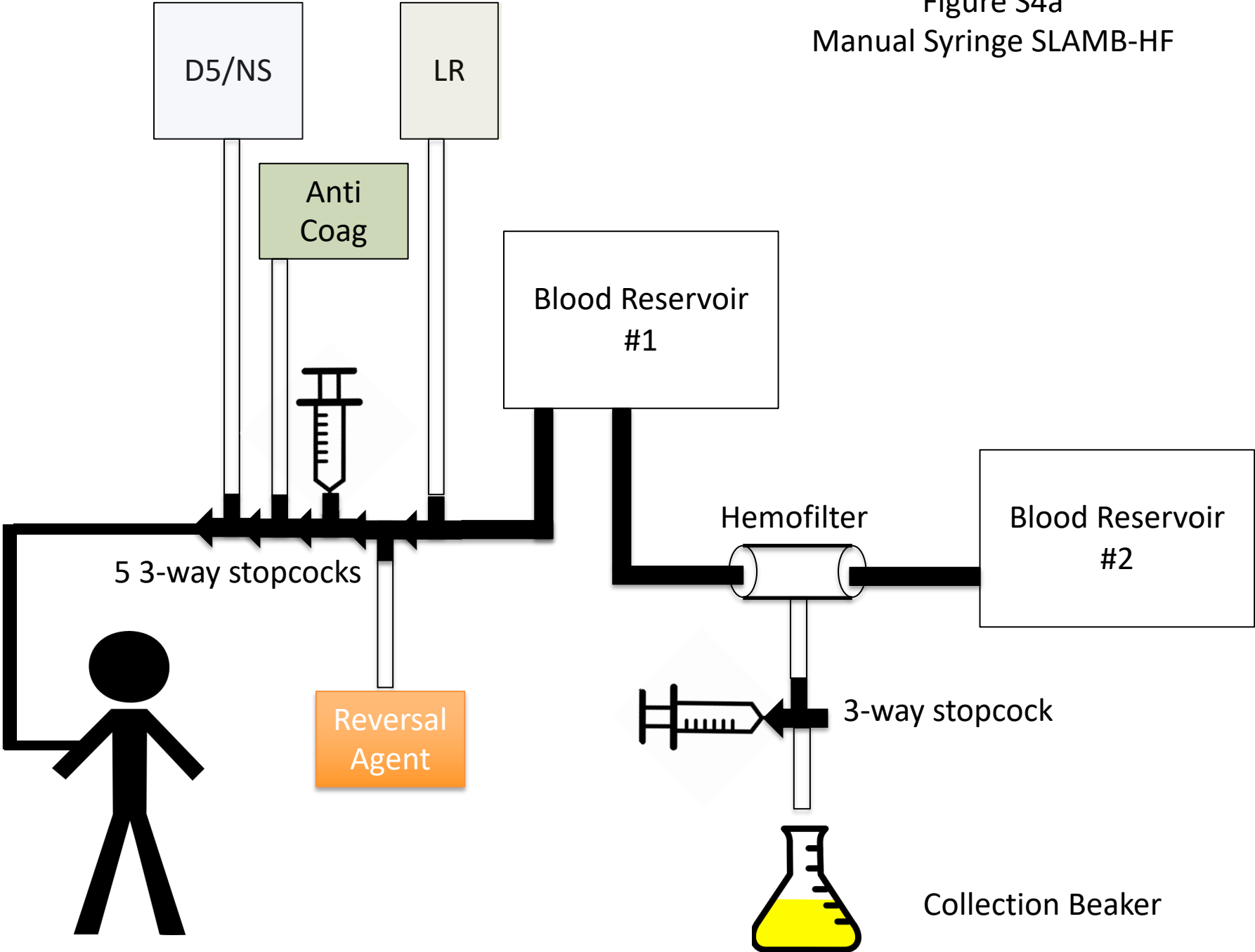

Figure S4b  
Manual Syringe SLAMB-HF  
D5/NS Fill

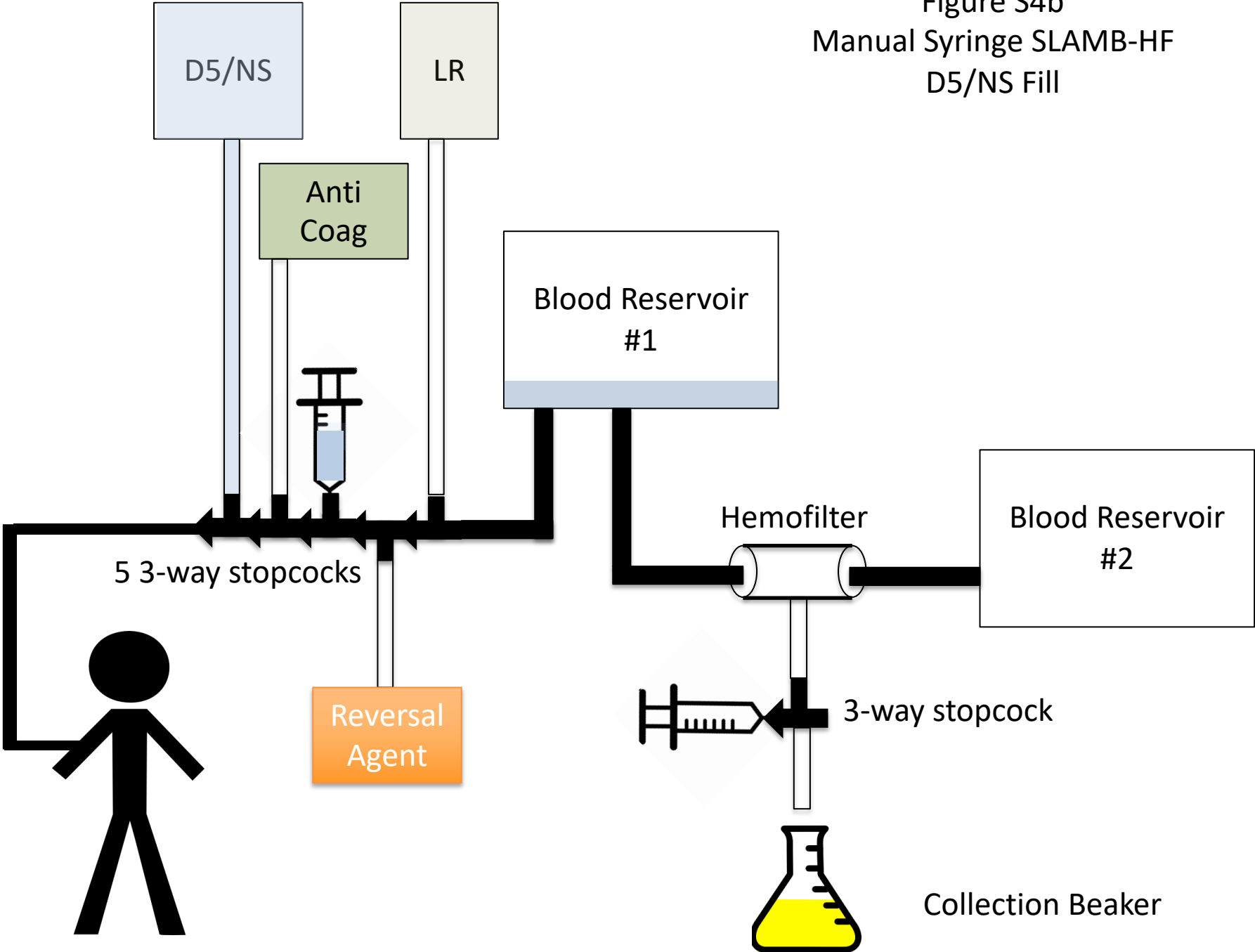

Figure S4c  
Manual Syringe SLAMB-HF  
Anticoagulation Fill

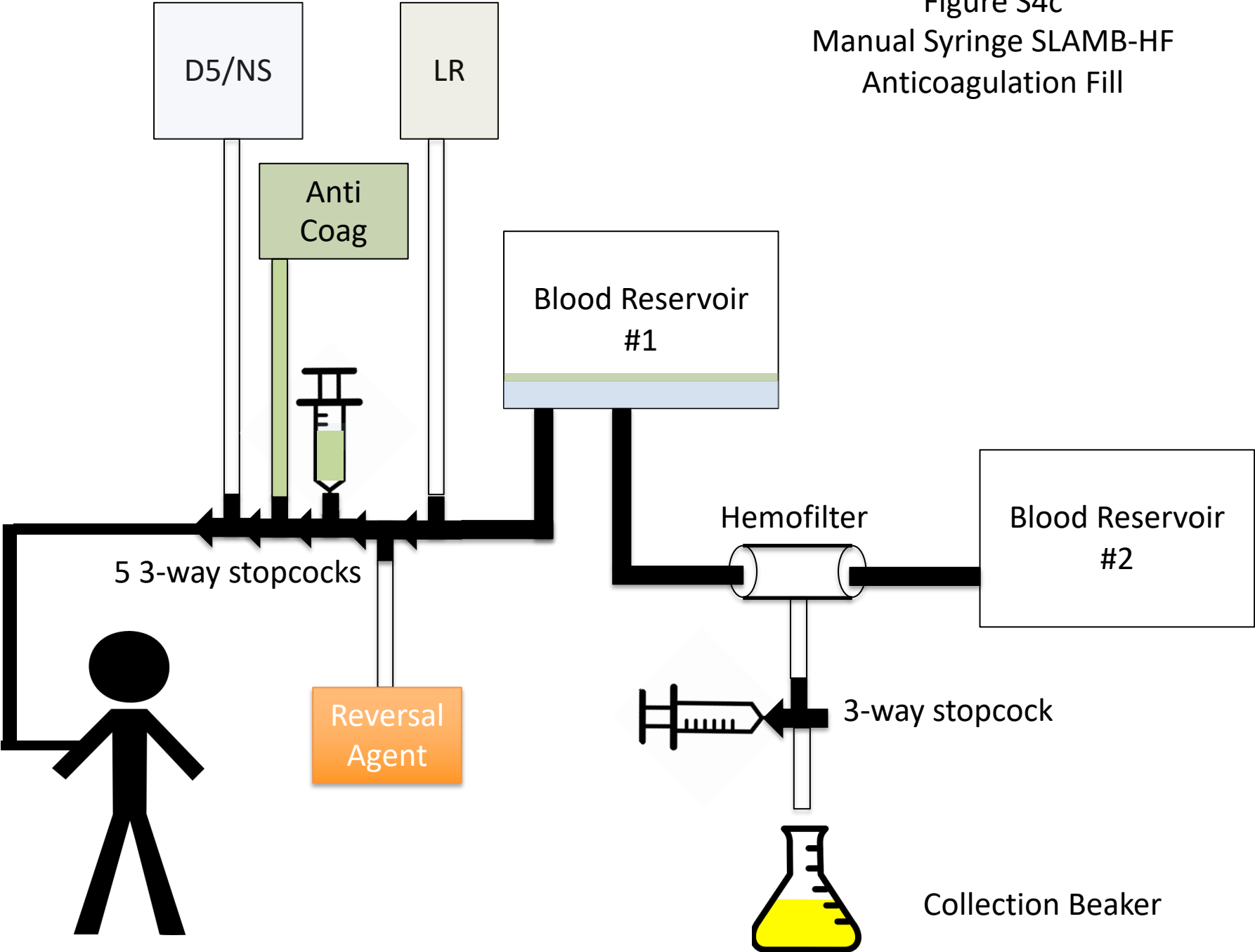

Figure S4d  
Manual Syringe SLAMB-HF  
LR Fill

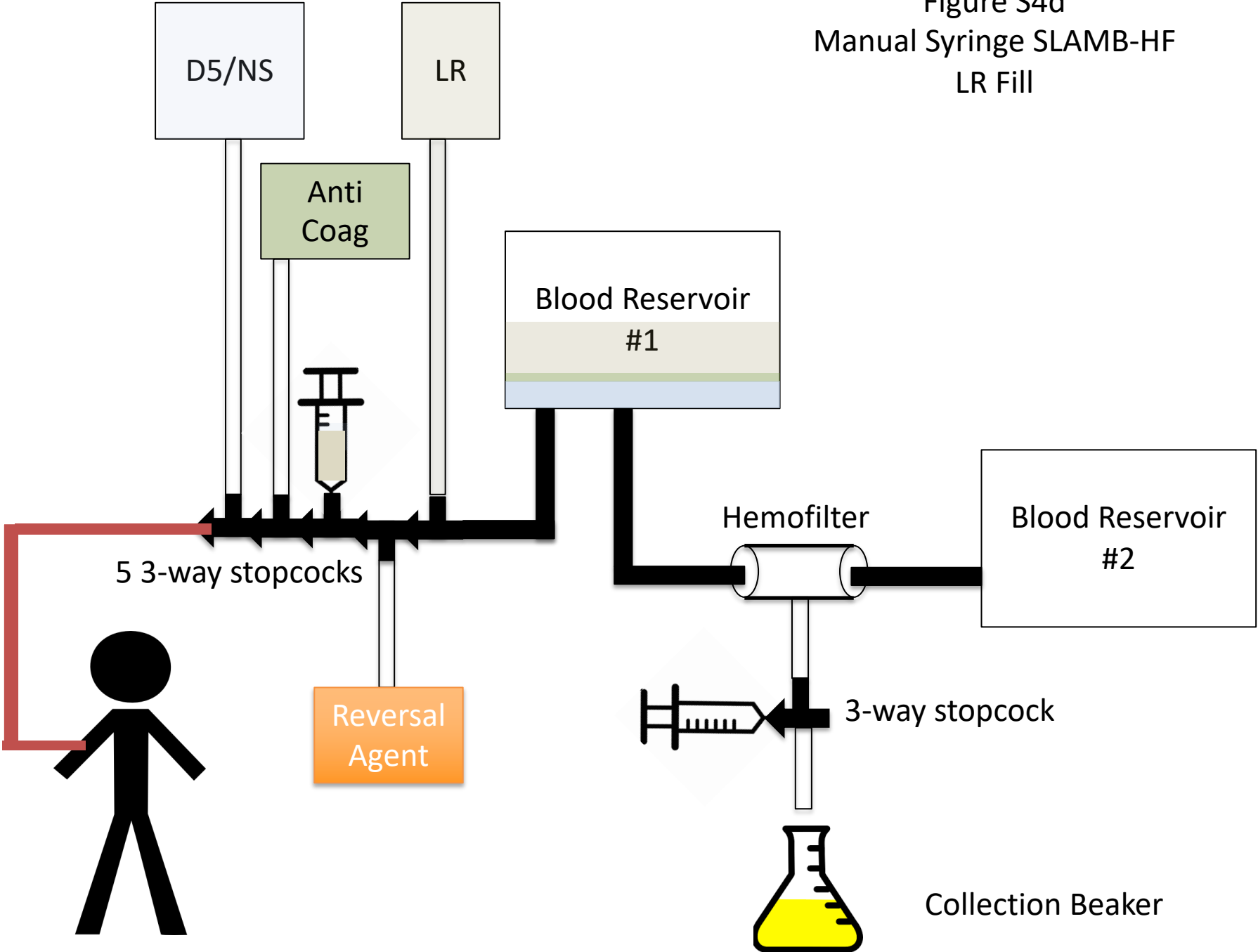

Figure S4e  
Manual Syringe SLAMB-HF  
Blood Fill

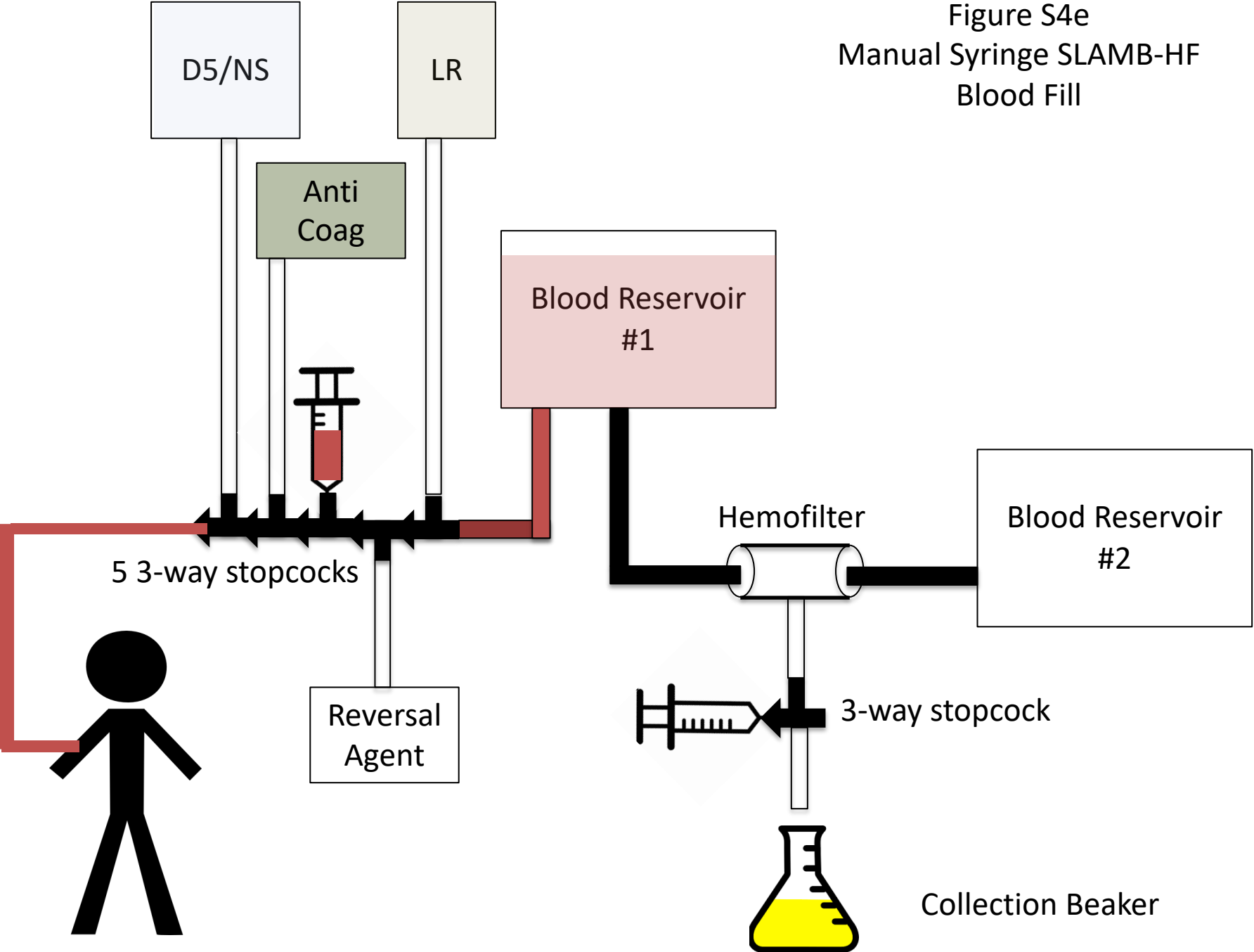

Figure S4f  
Manual Syringe SLAMB-HF  
Manual HF

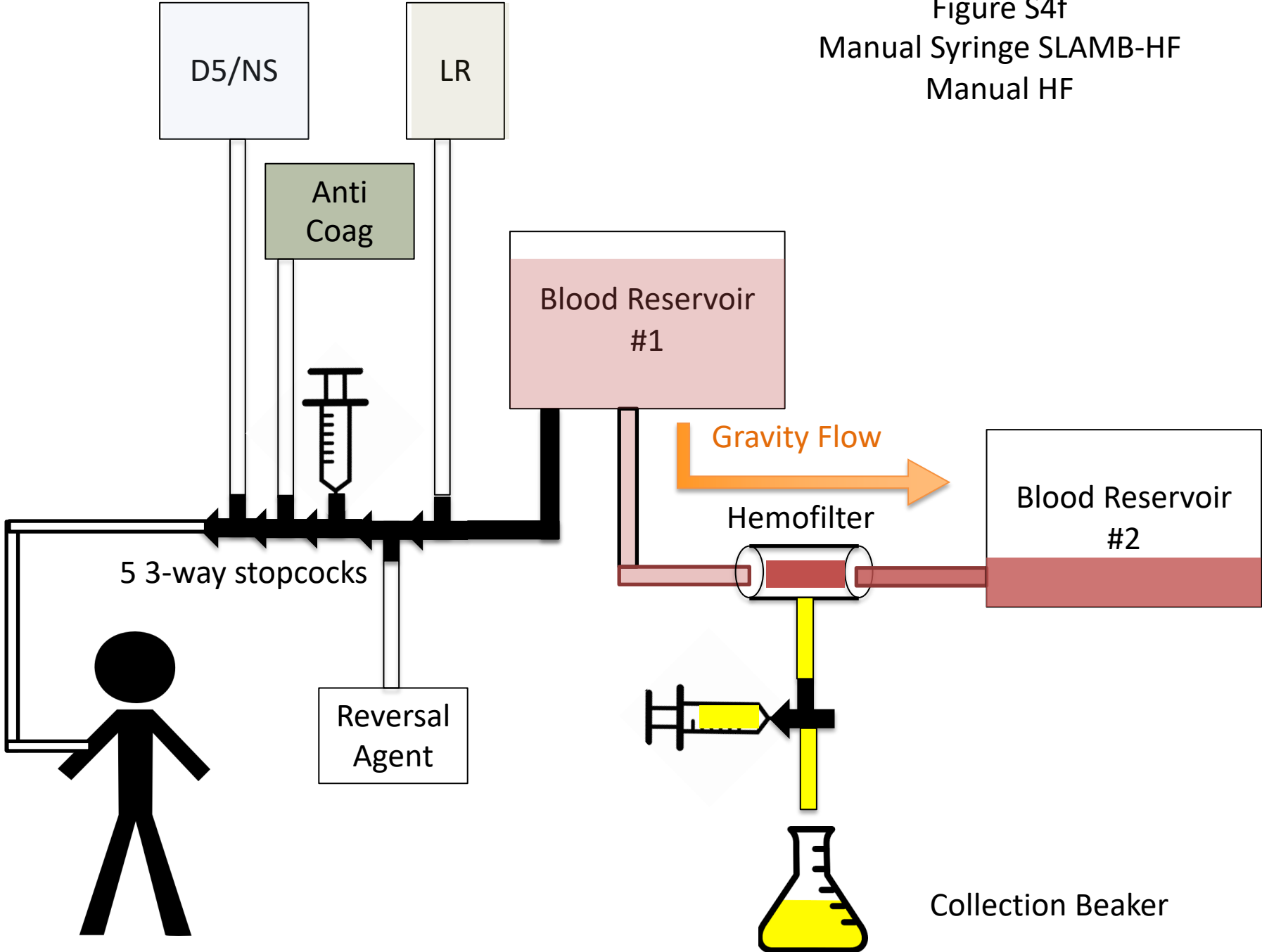



Figure S4g  
Manual Syringe SLAMB-HF  
Manual HF

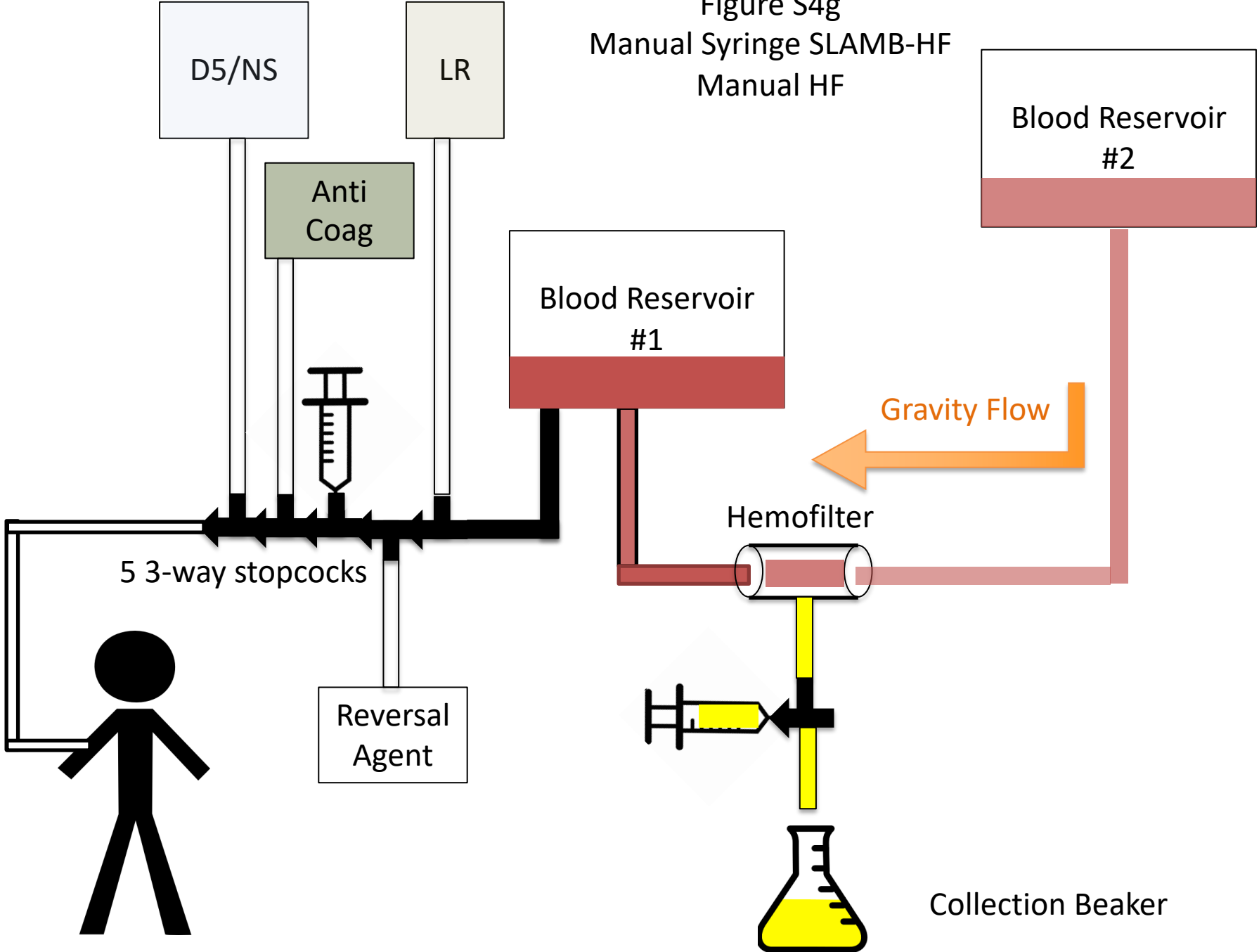

Figure S4i  
Manual Syringe SLAMB-HF  
Blood Return

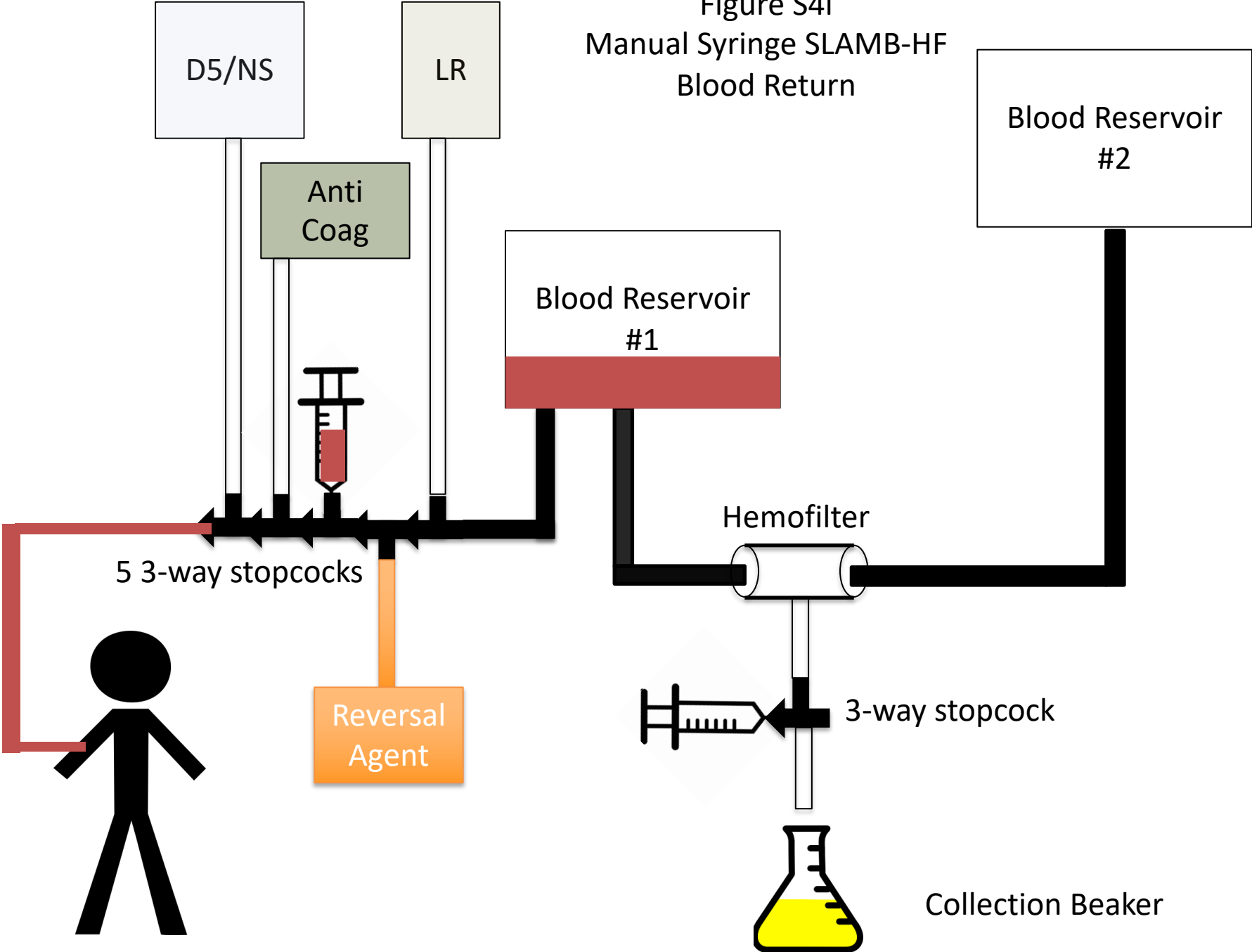

Figure S4j  
Manual Syringe SLAMB-HF  
Reversal Agent Given

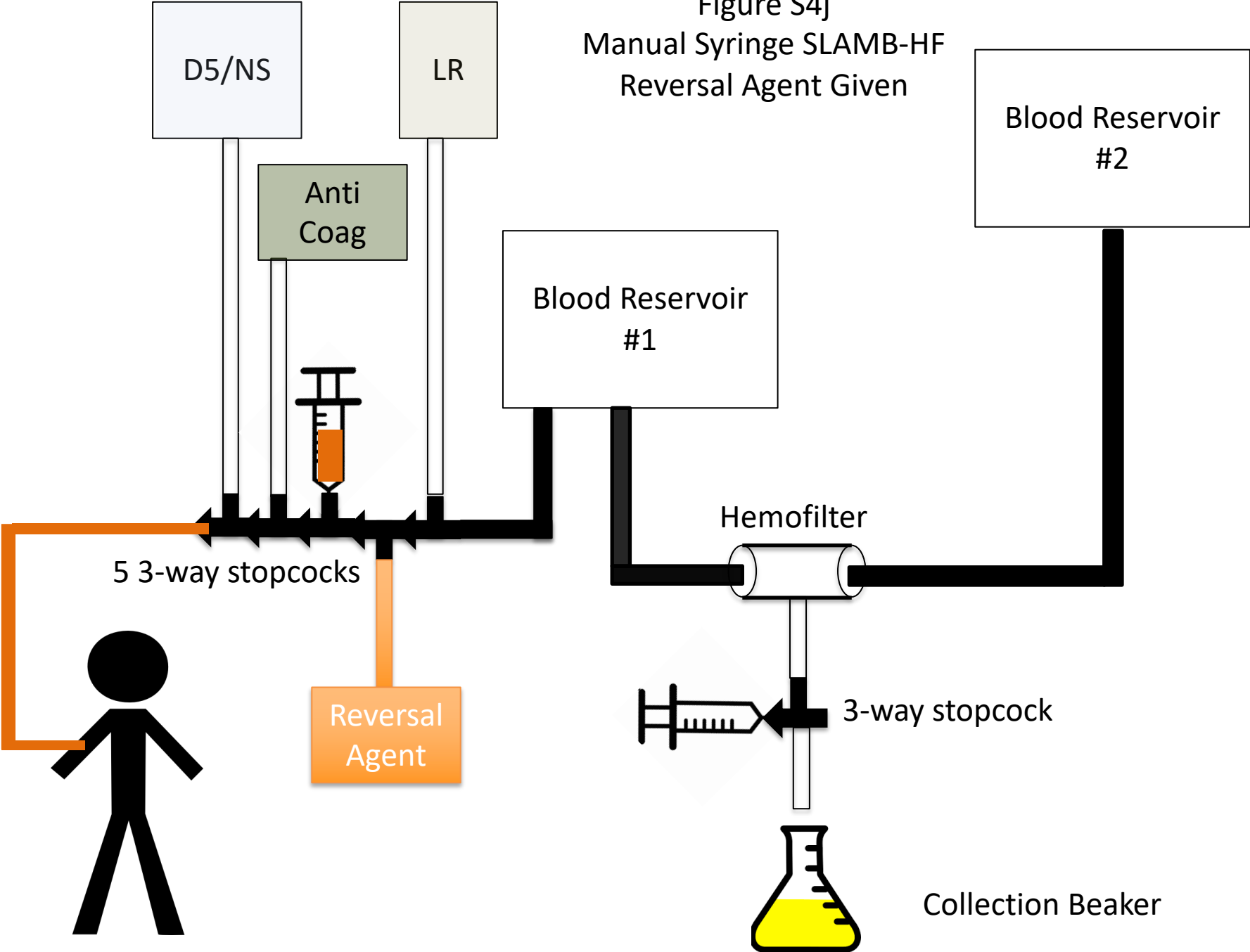
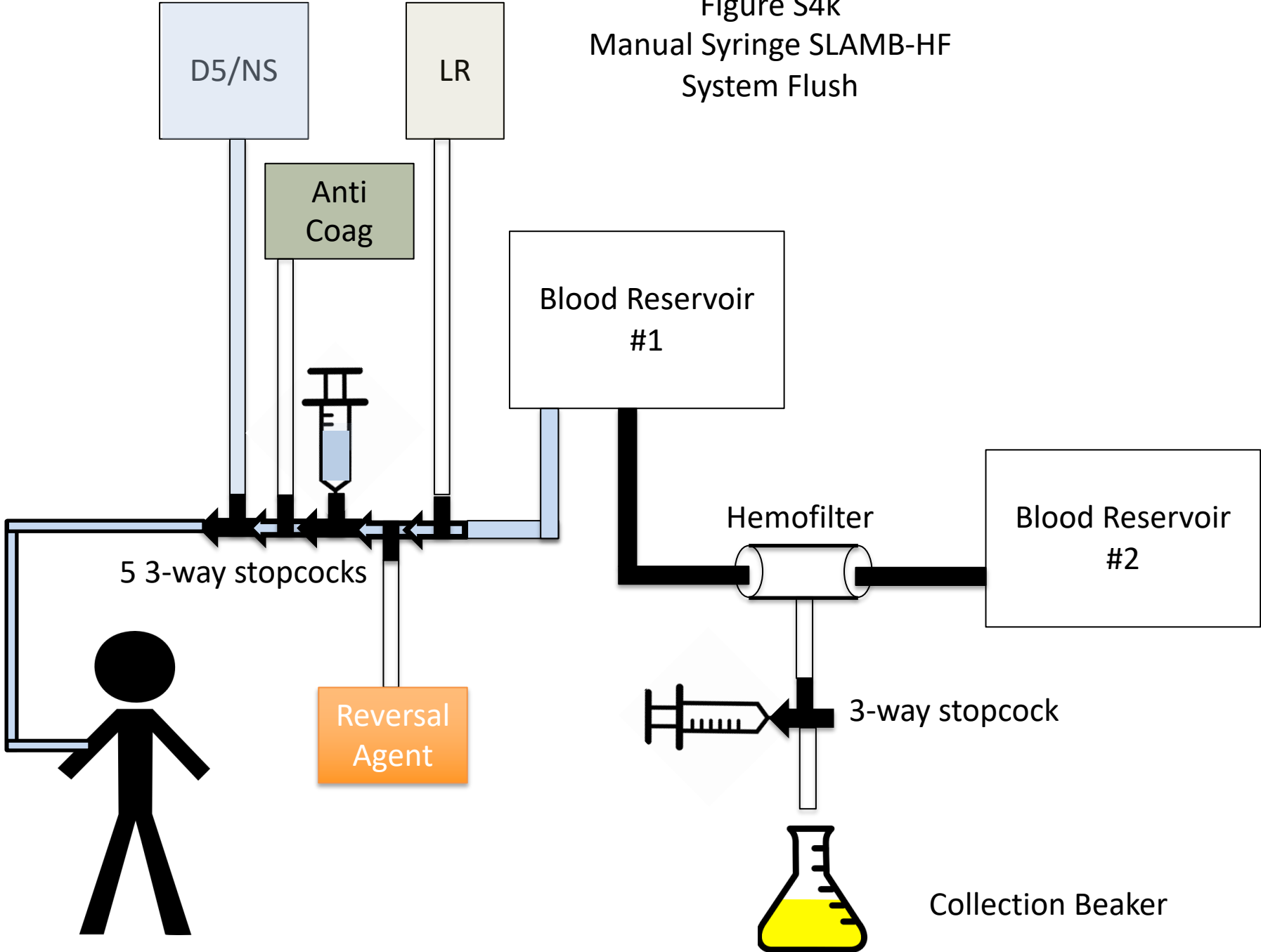
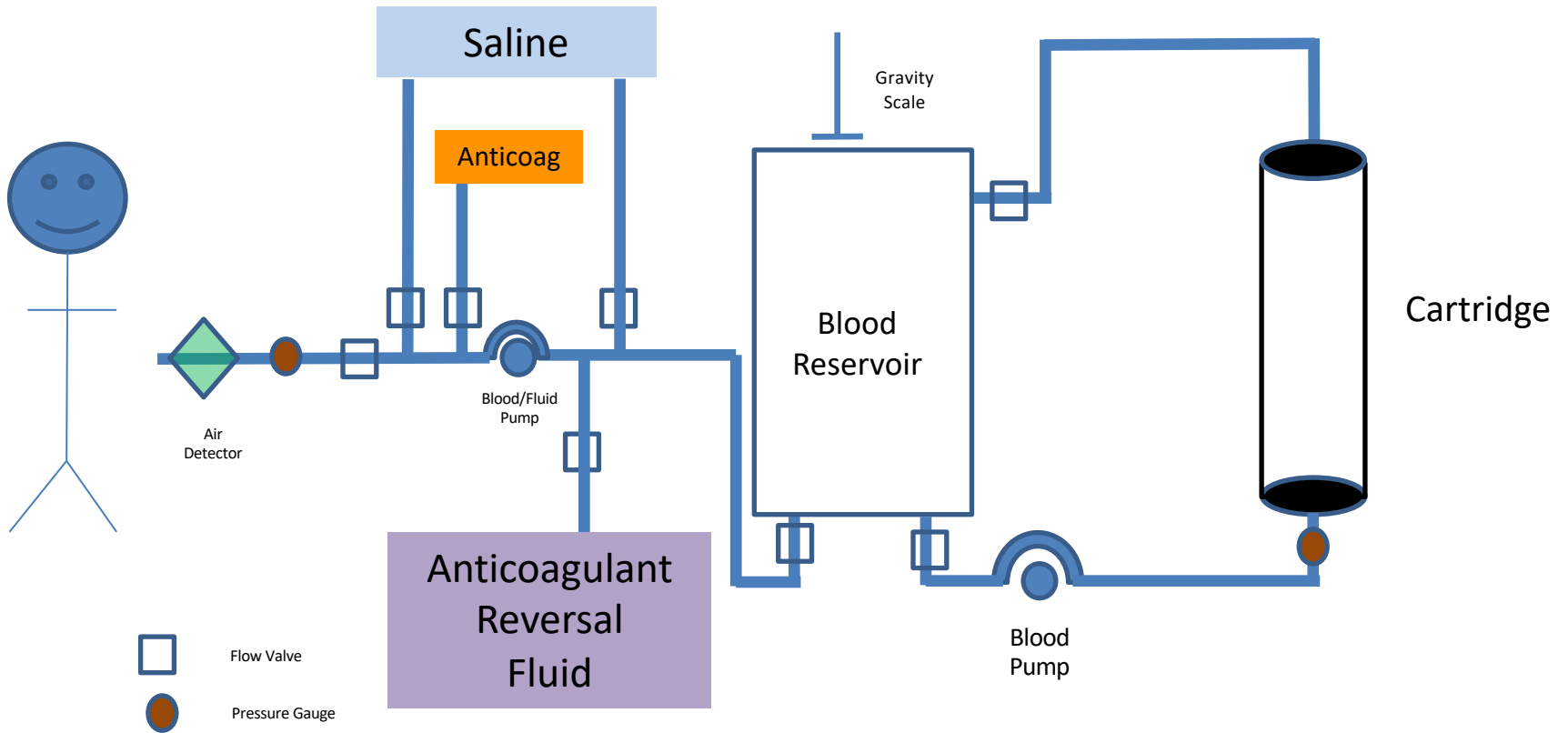

Figure S4k  
Manual Syringe SLAMB-HF  
System Flush



# SLAMB-HP



# SLAMB-HP

## Anticoagulation Fill

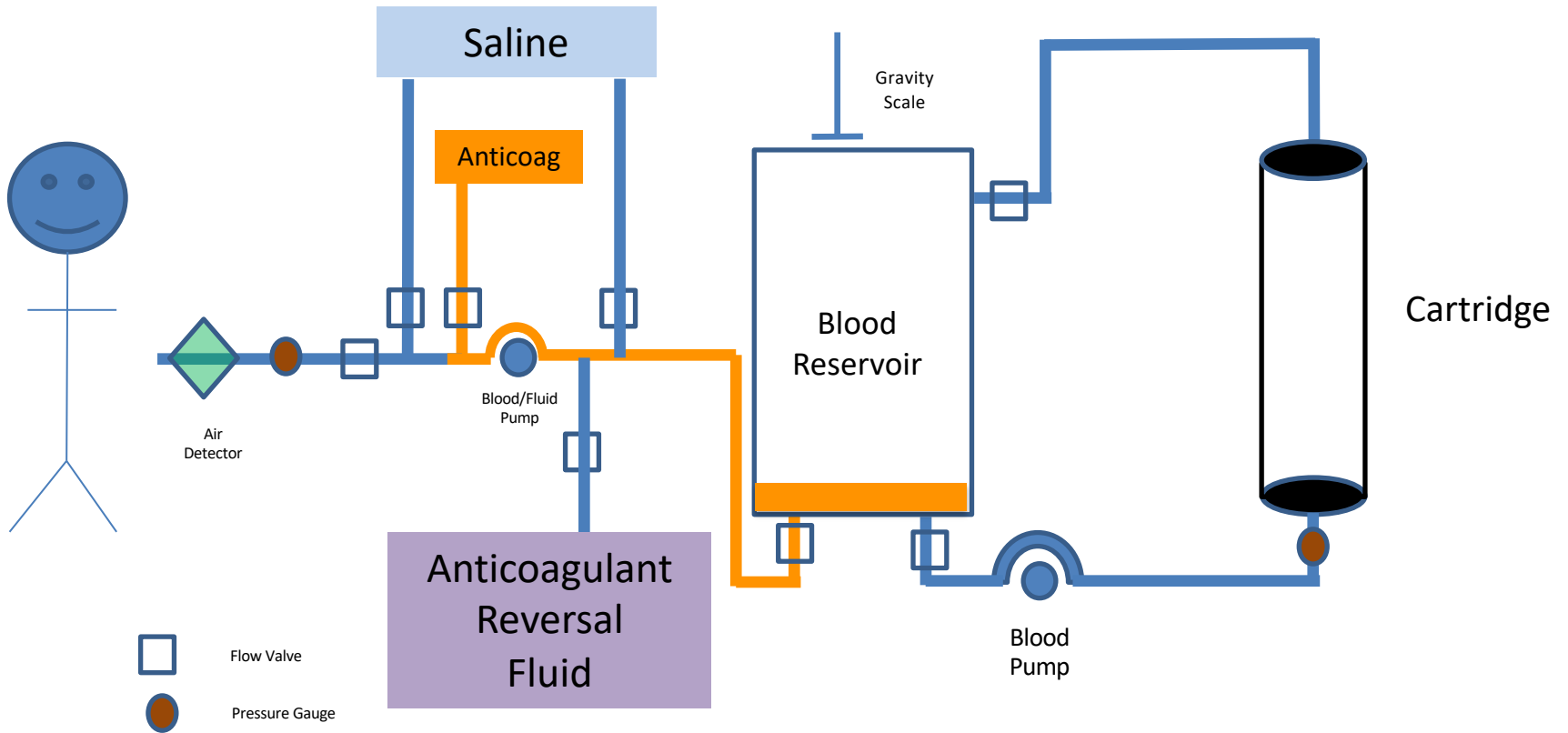

# SLAMB-HP

## Blood Fill

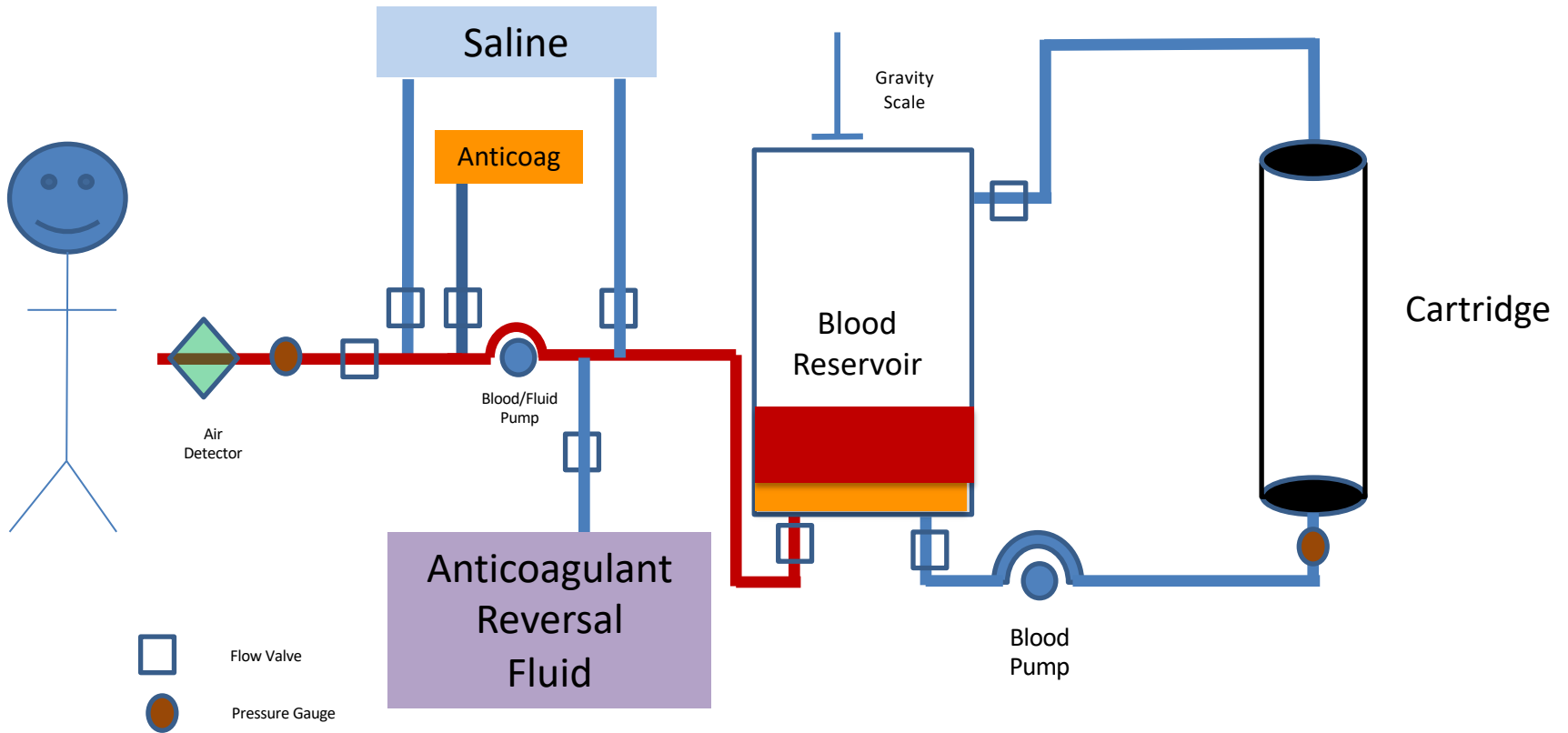

# SLAMB-HP

## Reservoir Fill

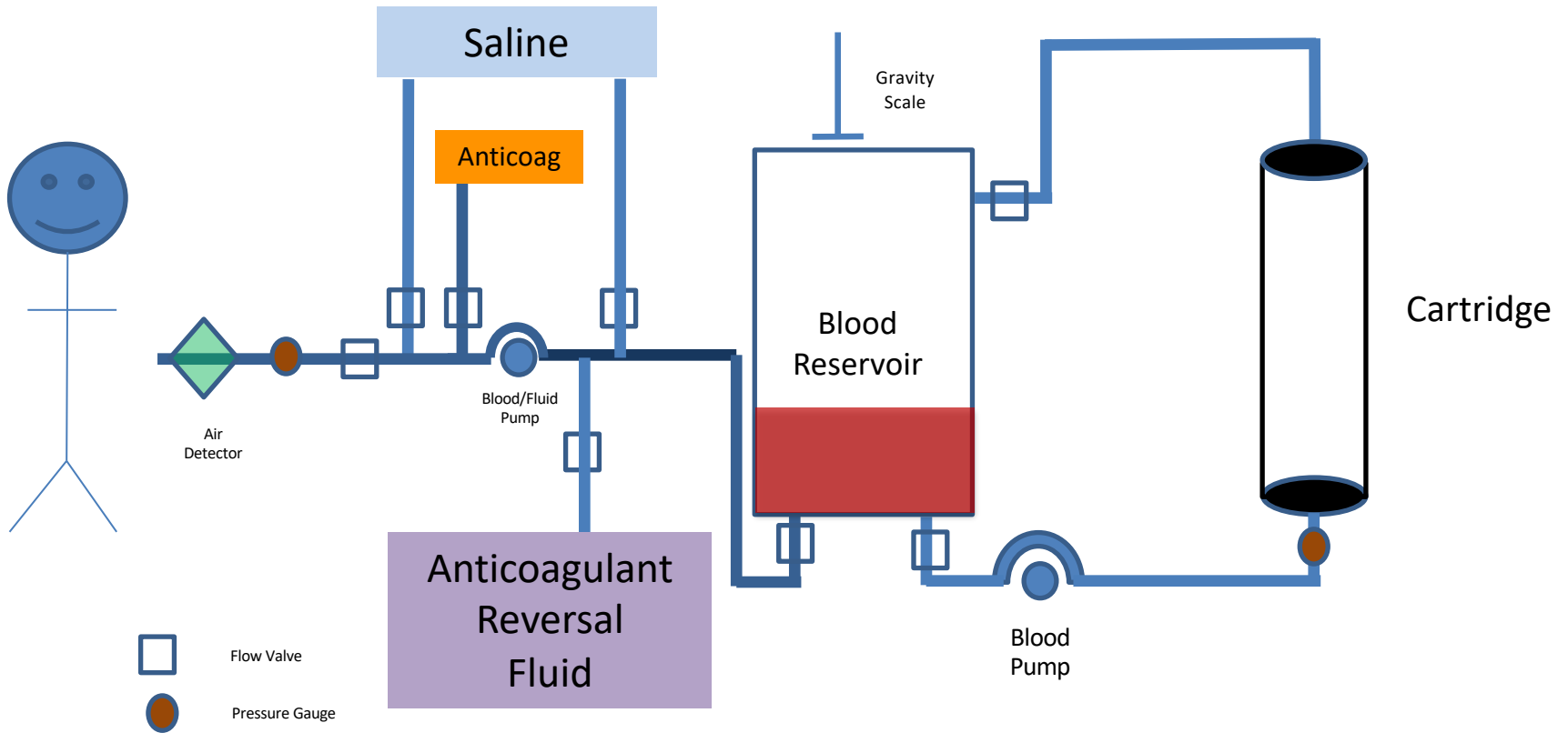



# SLAMB-HP

## Hemoperfusion

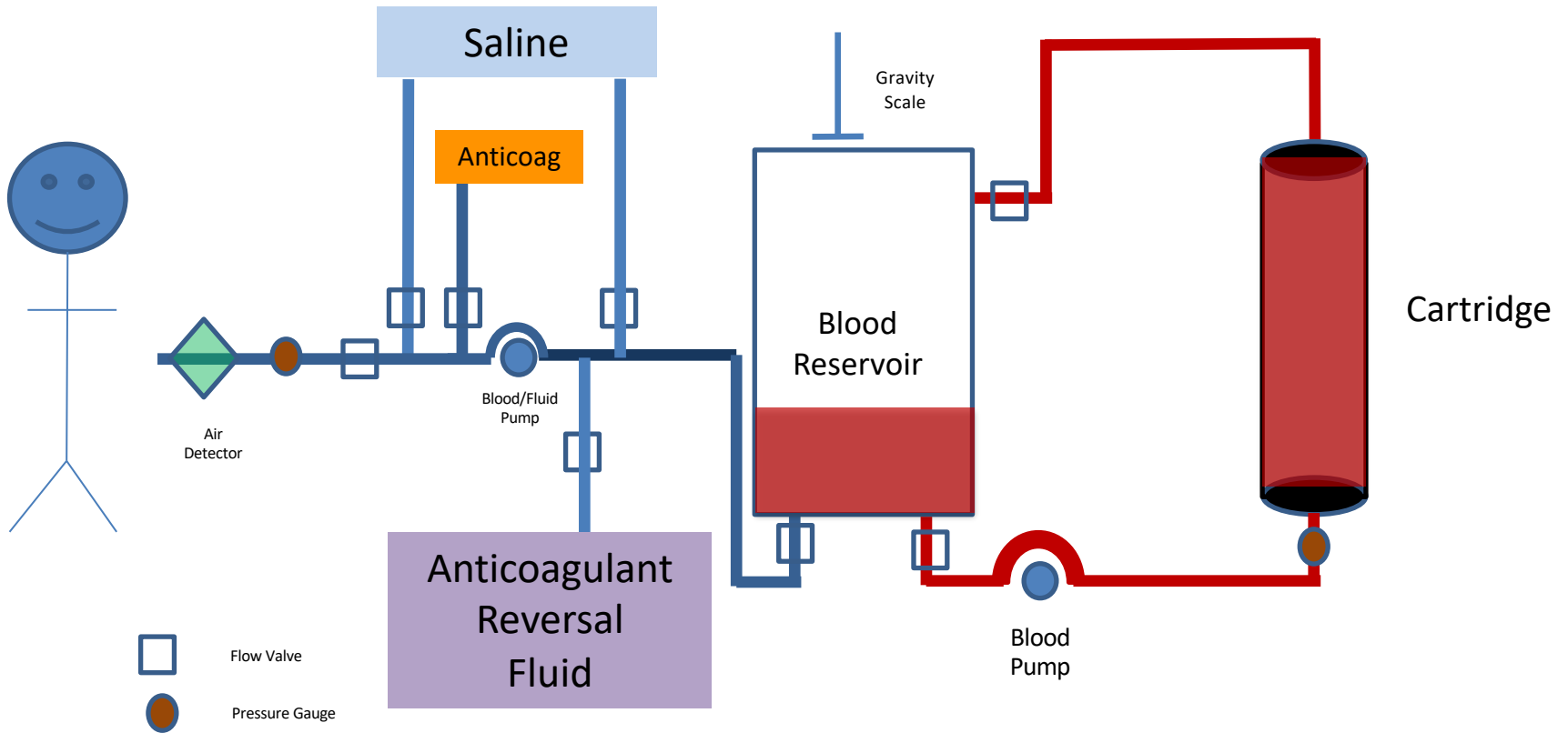

# SLAMB-HP

## Hemoperfusion Recirculation

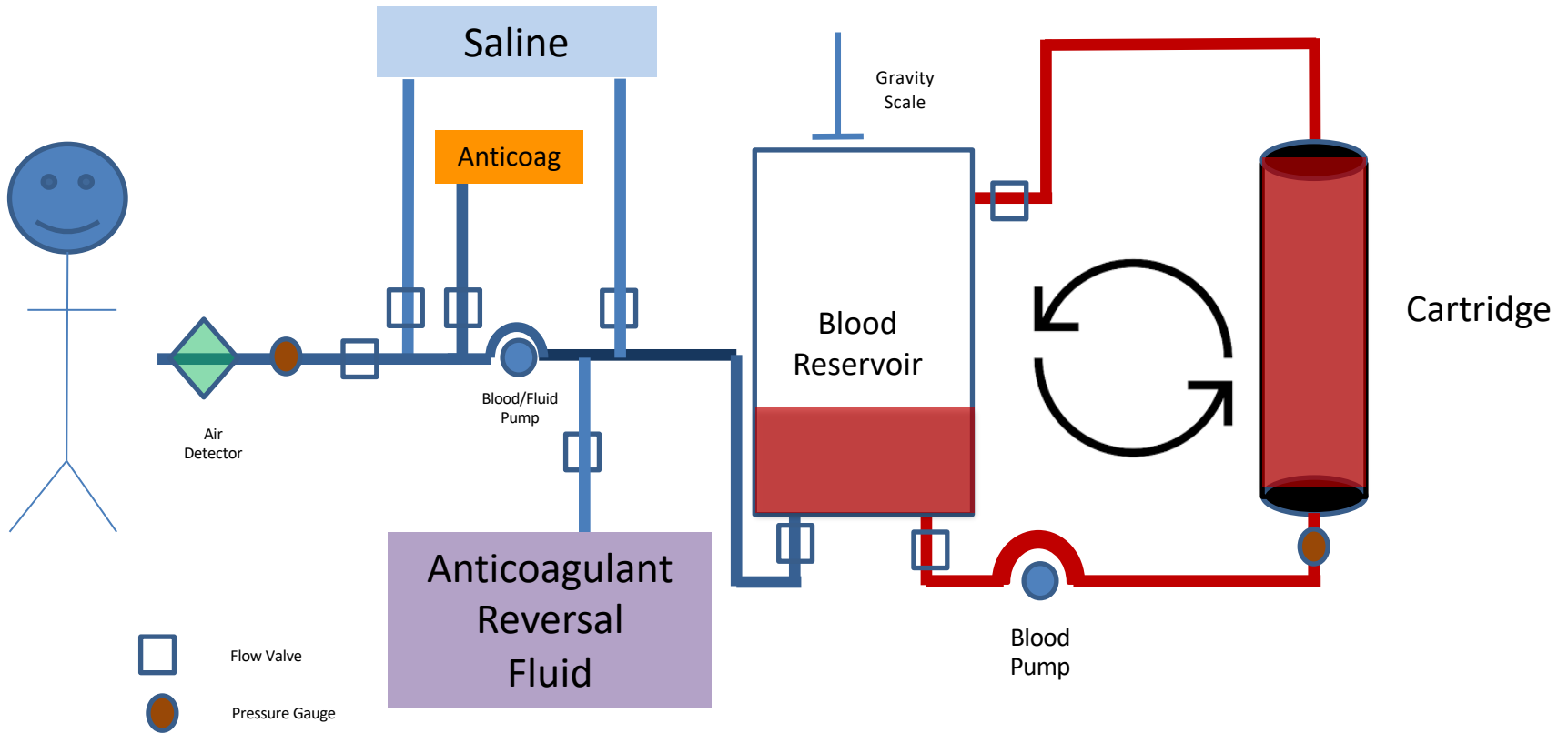

# SLAMB-HP

## Hemoperfusion End

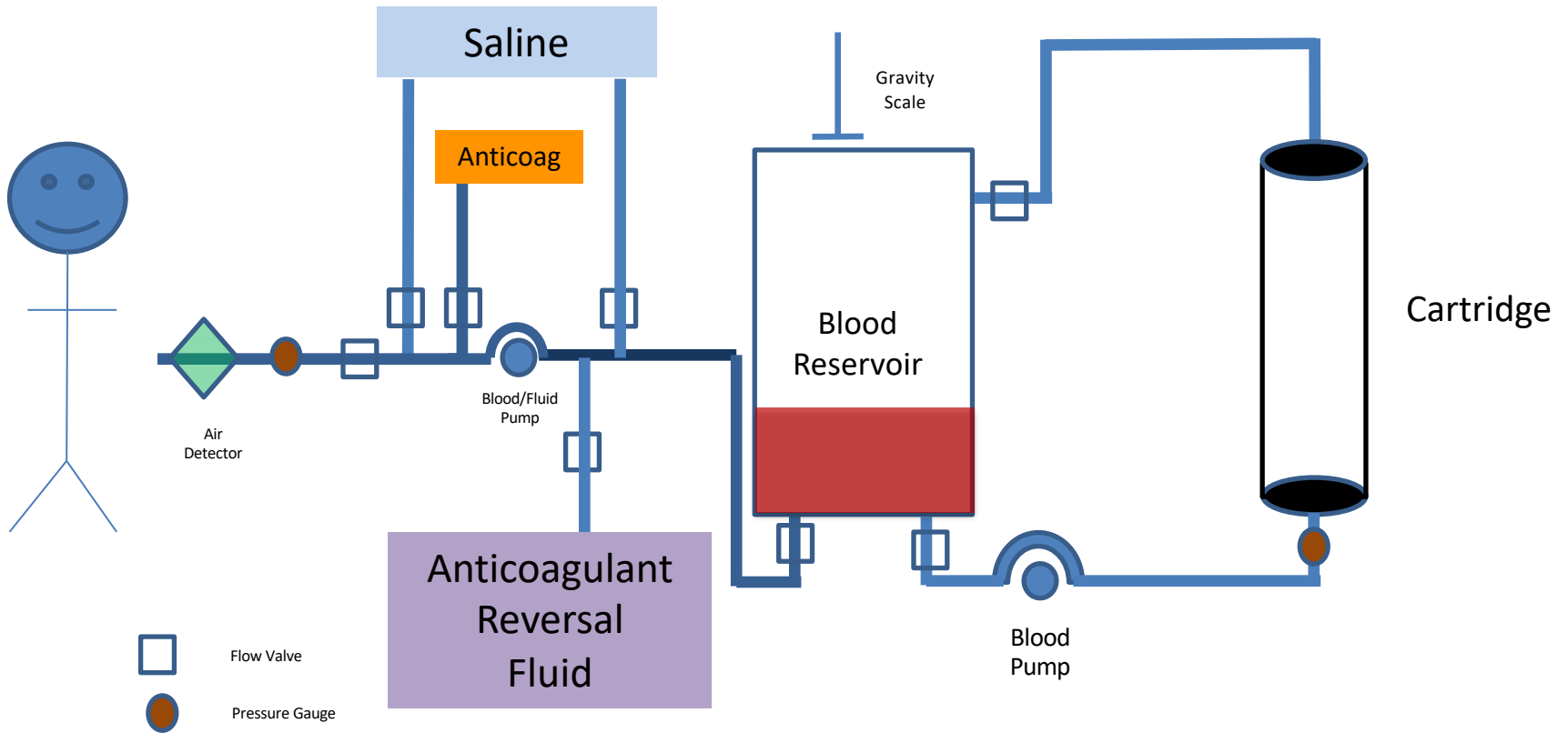

# SLAMB-HP

## Blood Return

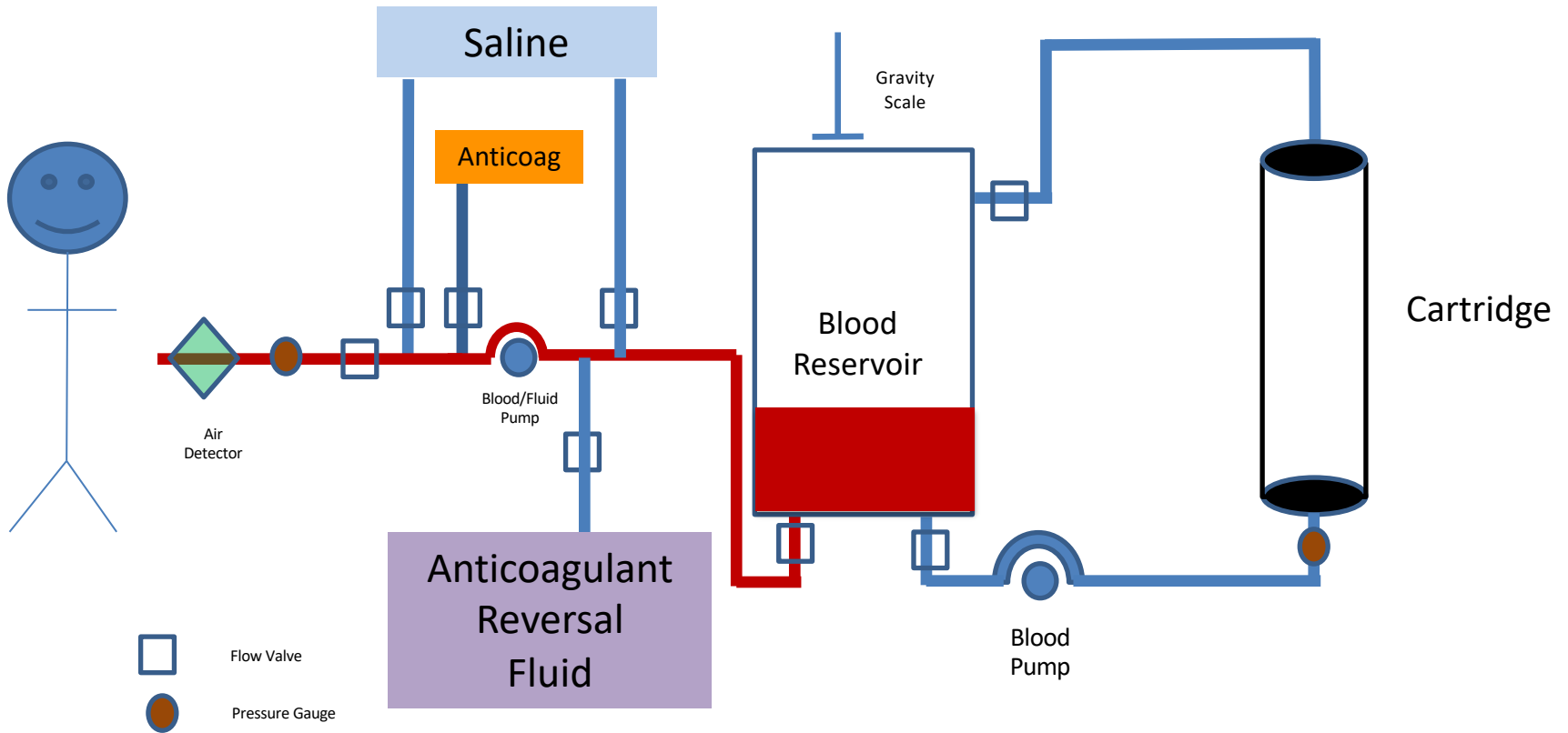

# SLAMB-HP

Reversal Agent Given

