

Cryogenic Flux Capacitor for Advanced Molecular and Energy Storage Applications

A M Swanger¹ and J E Fesmire¹

¹NASA Kennedy Space Center, Cryogenics Test Laboratory, Kennedy Space Center, FL 32899 USA

Email: adam.m.swanger@nasa.gov

Abstract. Effective storage and transfer of fluid commodities such as oxygen, hydrogen, natural gas, nitrogen, argon, and others is a necessity in many industries and for hosts of different applications. Molecules are typically contained as low pressure, cryogenic liquids; or as high-pressure gases. Liquefied gasses afford high energy and volume densities, but require complex storage systems to limit boil-off losses, need constant settling in zero-gravity, and are not well suited for overly dynamic situations where the tank orientation can change suddenly. Most cryogenic liquid tanks are complex, nested configurations to increase thermal performance, making them large, massive, and difficult to be made into conformal shapes. Conversely, high pressure gas storage bottles are unaffected by orientation, and can be kept at room temperature; however, these vessels are heavy-walled to contain the high pressures, and the energy densities associated with gas storage are dramatically lower. These two options are typically traded depending on the system requirements, but few practical options exist that provide the benefits while limiting the downfalls. Alternatively, the Cryogenic Flux Capacitor (CFC) technology employs nano-porous aerogel composites to store, by physisorption processes, large quantities of fluid molecules in a molecular solid-state condition, at moderate pressures and cryogenic temperatures. By virtue of its design architecture, a CFC device can be “charged” and “discharged” quickly and on-demand according to operational requirements. Three CFC application areas are introduced: CFC-Fuel, CFC-Cool, and CFC-Life, corresponding to designs utilizing fuels such as hydrogen and methane; inert fluids such as nitrogen and argon for cooling power; and oxygen or breathing air for life support. Data for physisorption within different aerogel composites are presented in terms of both mass and volumetric parameters.

1. Introduction

Storage and transfer of fluid commodities such as oxygen, hydrogen, natural gas, nitrogen, argon, etc. is an absolute necessity in virtually every industry on Earth. These fluids are typically contained in one of two ways: (i) as low pressure, cryogenic liquids; or (ii) as high-pressure gases. Cryogenic liquids afford high energy and volume densities but require complex storage systems to limit boil-off, need constant settling in zero-gravity environments, and are not well suited for overly dynamic situations where the tank orientation can change suddenly (in an airplane or car for example). The complex cryogenic liquid tanks include vacuum jackets and suspension systems between inner and outer vessels to enable storage of liquid with reasonably low boil-off losses. These tanks are large, heavy, and cannot be made in conformal shapes.

Conversely, high pressure gas storage bottles are not affected by tank orientation and can be kept at room temperature, hence are considerably less complicated pieces of equipment. However, these vessels

are heavy due to the thick walls required to contain the high pressures, and the energy densities associated with gas storage (even at extreme pressures up to 700 bar) are dramatically lower. These two options are typically traded depending on the system requirements, but few practical options exist that provide all the benefits while limiting the downfalls.

Occupying the middle ground between the two extremes described above, the Cryogenic Flux Capacitor (CFC) technology combines the energy storage capacity of liquefied gasses with the relative simplicity of high-pressure gas bottles by exploiting unique attributes of nanoporous, structural aerogel composite materials, in conjunction with unique and synergistic packaging. In a CFC-based storage system, fluid commodities such as oxygen, hydrogen, methane, nitrogen, and others can be stored in a molecular surface adsorbed state at densities on par with liquid, at cryogenic temperatures and low to moderate pressures, and then supplied as a gas, on-demand, to a point of need in the process.

Due to the insensitivity of the CFC with regards to the type of stored fluid, the technology has broad applicability. These applications tend to fall into one of three categories: CFC as a refrigeration power source, as a breathing air/oxygen source, or as a fuel source; and referred to as CFC-Cool, CFC-Life, and CFC-Fuel respectively in the context of this work. Potential CFC-Cool applications include time-release cold for cold-chain shipping of biological tissue and pharmaceuticals, cooling of sensors and electronics, and next-generation cryocoolers. CFC-Life applications include breathing air or oxygen packs for first responders, diving, medical, and space and aircraft life support. Finally, fuel pods for satellites, forklifts, and construction equipment, and fuel-cell powered vehicles lie within the CFC-Fuel application space.

2. Cryogenic Flux Capacitor (CFC) design and operation

Generally speaking, the CFC is an energy management device: providing a means to both store and access that energy on-demand, and in a practical way. The stored energy in this case is represented by a fluid in a solid-state manner. Solid-state storage means that individual fluid atoms or molecules are physically bonded within the pores of a meso-porous or nano-porous storage media, rendering them phase-less in a sense—either gas or liquid can be used to “charge” a CFC, but the molecules are not stored within the material in that phase; however, “discharged” commodity is always in the gas phase. The process of bonding or debonding is governed by principles of physical adsorption (physisorption) and thermodynamics [1]. Previous developments of storing cryogens in aerogel-based materials have been previously described [2-3].

A CFC device by itself does not constitute a fully engineered fluid storage/distribution system. Instead, it is a component (the module) at the heart of such a system, and provides the fluids designer with new and novel possibilities with which to achieve the ultimate goal of a design. A CFC core module is an integrated thermo-mechanical fluid delivery system containing the adsorbent material, geometric thermo-fluid delivery membrane, and a means of supplying heat for discharging (from either a synthetic or natural source). The module is contained within a separate pressure boundary, and thermally protected from the warm environment to increase hold times—the addition of which constitutes a CFC-based storage system. Geometric embodiments of a core module include a coiled cylinder, parallel plate (any shape), and conformal/non-symmetric shapes [4].

Some of the fundamental elements and features of the CFC technology are briefly described as follows. Included are the following elements: a nanoporous media for physisorption (substrate material); below-ambient working temperatures (refrigeration); and an integrated thermo-mechanical fluid delivery system (that is, the “CFC core module”). The necessary refrigeration can be provided in several different ways including: refrigeration provided by the fluid itself; refrigeration provided by mechanical conductive means; and/or refrigeration provided by a separate refrigeration loop (heat exchanger). The integral system design of the CFC core module means that the substrate material works in continuity for flux of fluid/molecules among three physical scales: nano, micro, and macro. This integral design provides pathways for molecules to travel and communicate with thermal interaction in the progression from macro to micro to nano (storage) and in the progression from nano to micro to macro (un-storage).

The CFC's packaging is ingeniously designed, tightly packing aerogel composite materials within a container allows for a greater amount of storage media to be packed densely and strategically. An integral conductive membrane also acts as a heat conduction element to easily distribute heat through the entire core for quick discharge of the CFC module. This membrane can also be interfaced to a cooling source for convenient system charging; this feature also allows the fluid to easily saturate the CFC module for fast charging. The module can be charged either with cryogenic liquid or from an ambient temperature gas supply, depending on the desired manner of refrigeration. Finally, the heating is accomplished by different methods to evenly distribute heat throughout the entire core, both axially and radially. Figures 1 through 3 show various parts of a CFC core module and example storage systems.

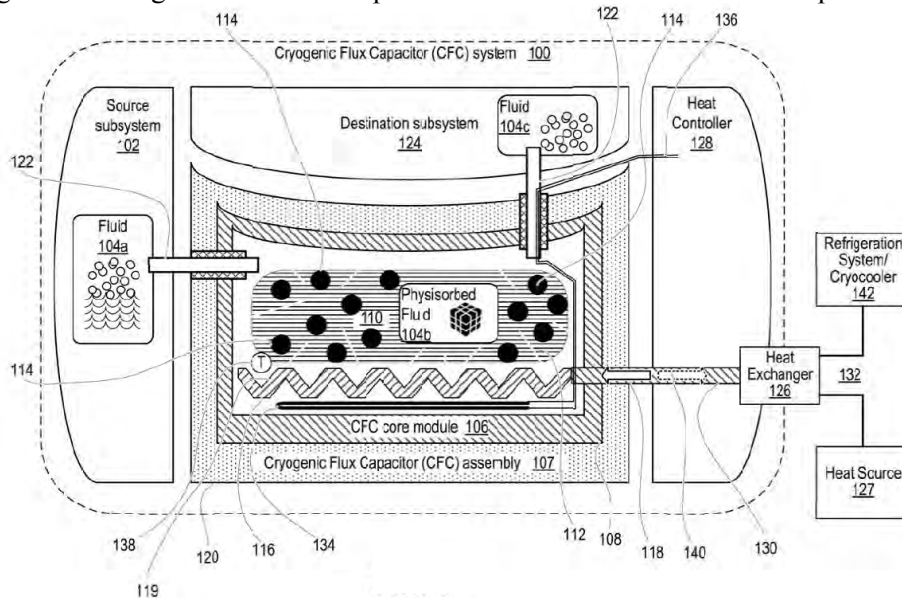

Figure 1. Generalized conceptual schematic for a CFC-based storage/distribution system [4]

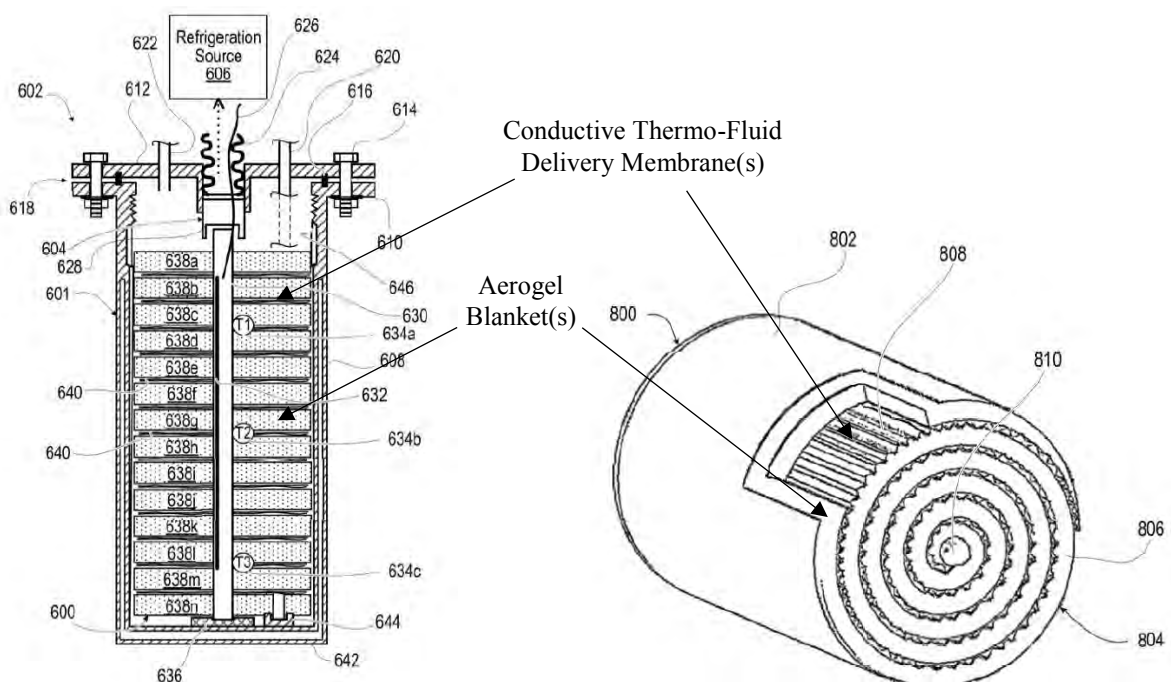

Figure 2. Conceptual schematic of a CFC in parallel plate (left), and spiral configurations (right) [4].

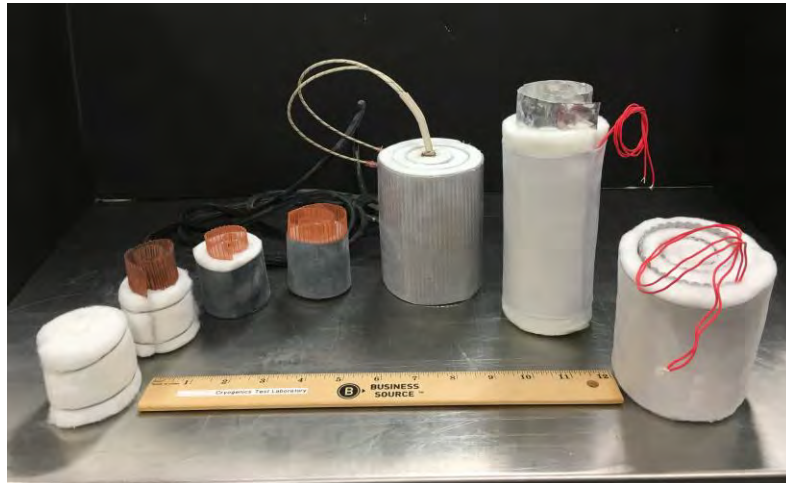

Figure 3. Various prototypes of CFC core modules (spiral configurations with different conductors).

The CFC module can store large quantities of fluid commodities at moderate pressures in a non-gaseous and non-liquid state (physisorbed state) at below ambient temperatures such as 200K, 100K, 77K or lower. The lower the temperature, the higher that the energy density (storage capacity). Being the middle ground between the two extremes of low pressure cryogenic liquids and high-pressure gases, the present the CFC technology presents a host of alternative and enabling applications. The goal is to store as many fluid molecules as possible in the smallest, lightest weight volume possible and to supply ("un-store") those molecules on demand as needed in the end-use application. The CFC addresses this dual storage/usage problem with a novel charging/discharging design approach.

Engineered as part of an energy storage system, the CFC can be used to store fluids at moderate pressures and then energized to provide a continuous, long duration gas supply which can be utilized for various operations (for example, argon for welding or inerting, hydrogen as fuel to an engine or fuel-cell, etc.). In addition, the configuration is extensible to other geometries and embodiments, not just the cylindrical examples shown here. Because the CFC has the ability to operate at ambient to moderate pressures, the technology can be exploited for numerous conformal geometries such as for tanks in vehicle compartments or personnel gear. Uses for such implementations includes future fuel tanks for liquid natural gas (LNG) or liquid hydrogen (LH₂) on vehicles including boats or planes.

3. Aerogel composite materials testing

Physical characterization of seven different aerogel composite blanket materials and three different CFC module prototype modules in nitrogen, air, and oxygen were performed. The test data for the CFC module prototypes, including storage capacity, burn-down rate, and dormancy time, are previously given [5]. Additional data using argon provides further comparison and analysis regarding the science of physisorption involved in these nano-porous high surface area aerogel materials. In this case, liquid nitrogen (LN₂), liquid air (L-Air), liquid oxygen (LO₂), and liquid argon (LAr) were used. As mentioned above, cryogenic liquids are not necessarily required if a separate refrigeration source is provided in conjunction with a gas supply, but in the present case, for practical simplicity in this research investigation, the given liquid provides both the refrigeration (low temperature) and the process gas supply (N₂, Air, O₂, or Ar).

All materials were manufactured by Aspen Aerogels and all but one (ultra-low density or ULD) are commercially available. These materials are used in a very wide range of industries and applications from oil and gas (subsea piping insulation, for example), process plants (high temperature reactors), building construction, high-performance cryogenic systems, apparel, to many other areas.

Materials characterization was achieved in two ways: fluid mass uptake, and boil-off calorimetry. The mass uptake is the net mass of a given fluid, in grams, that is physisorbed within the specimen. Boil-off calorimetry was used to determine the energy associated with "charging" the material or CFC

module. The volume of a given material specimen is calculated in cubic centimeters. The following parameters are calculated and analyzed: Liquid Volume Equivalent (LVE), Volume Ratio (VR), Mass Ratio (MR), and Total Charging Heat (TCH). These parameters are defined as given in Equations 1-4:

$$\text{LVE [cm}^3\text{]} = \text{mass uptake [g]} / \text{liquid density at Normal Boiling Point (NBP) [g/cm}^3\text{]} \quad (1)$$

$$\text{VR} = \text{volume of fluid} / \text{volume of material} = \text{LVE} / \text{volume of material} \quad (2)$$

$$\text{MR} = \text{mass of fluid} / \text{mass of material} = \text{mass uptake} / \text{mass of material} \quad (3)$$

$$\text{TCH} = \text{sensible heat of specimen} + \text{heat of adsorption} \quad (4)$$

3.1 Aerogel materials testing by basis of mass uptake

Mass uptake testing was performed on seven different materials with five test specimens for each material. Specimens were immersed in a cryogenic liquid for cooling and charging to maximum molecular storage capacity, and then immediately placed onto a weight scale. For statistical comparison, this procedure was conducted three different times for each of the five specimens, totaling 15 tests per material. These data were then averaged. Physical characteristics for the aerogel materials are given in table 1, and photographs of the LO₂ test set-up in are shown in figure 4.

Table 1. Physical characteristics of aerogel composite material test specimens.

Material	Samples	Nominal Diameter	Avg. Thickness	Avg. Density	Avg. Volume	Avg. Mass
		<i>mm</i>	<i>mm</i>	<i>g/cm³</i>	<i>cm³</i>	<i>g</i>
Spaceloft White	5	76.2	4.8	0.146	21.8	3.19
Spaceloft Gray	5	76.2	4.8	0.148	21.8	3.23
Spaceloft Subsea	5	76.2	4.6	0.155	20.7	3.21
Spaceloft Subsea Gray	5	76.2	5.1	0.134	23.4	3.14
Pyrogel	5	76.2	4.9	0.236	22.2	5.24
Cryogel	5	76.2	4.3	0.167	19.6	3.28
ULD White	4	76.2	5.0	0.046	20.8	1.18



Figure 4. Dewar bowl of liquid oxygen prepared for mass uptake testing of aerogel materials (left); fully charged aerogel specimen being removed from bowl before placement on weight scale (right).

From the cryoadsorption mass data, three different metrics were calculated for comparison across all aerogel material types: LVE, as defined in equation 1, VR from equation 2, and MR from equation 3. These results are summarized in table 2. Each data point represents an average of 15 tests (five specimens, three tests each).

Table 2. Cryoadsorption test summary for aerogel materials.

Material	Test – N ₂			Test – Air			Test – O ₂			Test – Argon		
	MR	VR	LVE	MR	VR	LVE	MR	VR	LVE	MR	VR	LVE
Spaceloft White	4.8	0.87	19.0	5.8	0.96	20.9	7.0	0.89	19.4	7.7	0.87	19.0
Spaceloft Gray	5.1	0.94	20.4	6.2	1.02	22.2	7.3	0.95	20.5	7.9	0.90	19.5
Spaceloft Subsea	5.2	0.99	20.5	6.2	1.09	22.5	7.4	1.00	20.7	7.9	0.94	19.4
Spaceloft Subsea Gray	5.4	0.90	21.0	6.2	0.96	22.5	7.6	0.90	20.9	8.3	0.86	20.1
Pyrogel XTE	3.1	0.90	19.9	3.9	1.04	22.9	4.6	0.95	21.1	5.2	0.91	20.1
Cryogel	5.2	1.00	20.2	5.7	1.07	21.0	7.1	1.03	20.3	7.4	0.95	18.6
ULD White	7.2	0.51	13.1	7.6	0.52	13.4	9.3	0.55	12.6	10.8	-	-

The mass ratio provides a direct quantitative measurement in the experimental sense while the volume ratio is an important metric from an application-based point of view as it influences the overall envelope of the storage system design, and is a direct comparison of the CFC to storage of the fluid at its normal boiling point (i.e. traditional cryogenic liquid storage). For the samples tested, the material volume was shown to be roughly equivalent to the LVE for the main materials of interest (i.e. VR≈1 for most samples). That is, a material volume of 100 cm³ will provide a “NBP liquid equivalent” of 100 cm³ of the desired molecule, which translate to of 87,711 cm³ of gas at ambient conditions (for oxygen).

These data represent approximately 510 individual test runs. The progression across the different gas molecules stored makes good sense across the board. All the Spaceloft materials and the Cryogel are shown to be quite similar. The heavier Pyrogel (with its additives for high temperature applications) and the much lower density ULD-white show significant difference from the main group. Many factors would affect what material is ultimately down-selected for a particular CFC application, but Cryogel and the Spaceloft families are quite economical and are readily available. All prototype CFC modules constructed and tested to-date utilized Cryogel.

3.2 Aerogel materials testing by basis of boil-off calorimetry

Testing to estimate the Total Charging Heat (TCH) was performed on four aerogel materials: Spaceloft White, Spaceloft Subsea, Cryogel, and ULD White using three cryogenes, LN₂, L-Air, and LO₂. Ambient temperature specimens were placed into a wire hanger assembly, and then immersed into the test cryogen until fully thermalized. By recording the change in mass of the flask with cryogen, both before and after immersion, and subtracting the known amount of the mass boiled off for cooldown of the wire hanger (from separate calibration testing), the net mass consumed was determined. Further subtracting the known amounts of mass uptake reported above for the given material yielded the total boil-off mass attributed to the TCH.

The TCH is reported in mass units, and can be interpreted as the equivalent mass of liquid required to fully cool and saturate the aerogel material. As given in equation 4, the TCH is comprised of two quantities of heat energy—the sensible heat of the material from ambient to the NBP of the test fluid, and the heat of adsorption—the total of which can be estimated by multiplying the TCH by the heat of vaporization of the test cryogen. The small amount of boil-off mass associated with the heat leak of the vacuum test flask itself was not accounted for in this analysis, but is negligible on the time scale to quench a specimen (~30-40 seconds). In figure 5, an aerogel test specimen inside a calibrated wire hanger is shown being removed from flask of liquid oxygen during boil-off calorimetry testing. Graphical results for TCH are presented in figure 6, along with the material mass for comparison.



Figure 5. Aerogel specimen under LO₂ boil-off calorimetry testing used to calculate the TCH.

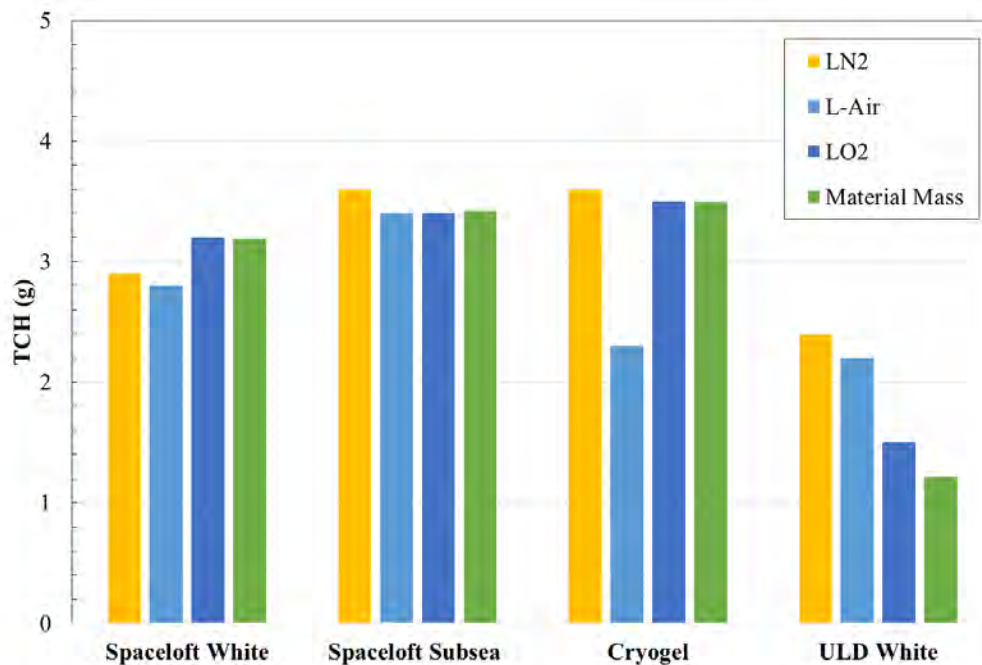

Figure 6. Total Charging Heat (TCH), in comparison with aerogel material mass.

4. Design considerations for CFC-based applications

From the testing of the aerogel composite materials, the main design parameters can be established for a given material and fluid combination, and applied to a particular design problem. Within the Cryo-Life category, a CFC module is currently being developed for oxygen respirator applications [5]. In this case, the VR parameter is of primary importance due to volumetric constraints placed on the overall system. If, however, a mass-sensitive application such as an airborne drone is being examined, then the MR is perhaps a better metric to aid in down-selecting an aerogel material as it reveals the most stored fluid mass per mass of adsorbent available. For the respirator development mentioned above, the Cryogel material was chosen because it provides the largest average VR for oxygen at 1.03. Conversely, the ULD White material gives a significantly higher MR at 9.3, versus 7.1 for Cryogel, but fell short with a VR of only 0.55.

Charging/discharging methods as well as dormancy considerations (stand-by time) are also key in the design of a CFC-based system. Charging can be as simple as exposing the aerogel material within the CFC module directly to the liquid cryogen of interest. This method can be relatively straight forward for liquids such as LN₂ and LAr, but can be challenging for flammable fluids such as LH₂. Another option is “liquid-free” charging, where a CFC module is thermally connected to a cryocooler cold head, or other source of refrigeration, and exposed to the process gas for adsorption at any below-ambient temperature according to the refrigeration capacity available. This method is slower than immersion, but may prove to be a more practical option depending on the application requirements. Discharging requires heat be provided to the CFC module. The source of this heat can be supplied from a resistive heater or exothermic chemical reaction for example, or can be pulled from the ambient environment or process by means of integral heat exchange hardware.

Containment of the CFC module (i.e., the process pressure boundary) and associated process fluid is application specific, but can be any variation or combination of the following approaches depending requirements such as the working pressure and desired dormancy time: simple mechanical insulation wrap, a vacuum-jacketed vessel, or an uninsulated vessel manufactured from an appropriate material. For non-pressurized systems with longer dormancy requirements, the thermal insulation must deliver the highest thermal performance. On the other hand, systems designed for higher pressures and shorter dormancy times require a lesser level of thermal performance from the insulation.

Unlike stored liquids, CFC modules are orientation independent, and hence are unaffected by dynamics such as shock and slosh. This advantage gives them utility in both gravity and zero-gravity environments, and provides opportunities for unique and novel packaging schemes that aid in isolating the cryogenic core from the warm ambient conditions.

5. Conclusion

The Cryogenic Flux Capacitor (CFC) technology capitalizes on the energy storage capacity of liquefied gasses and relative simplicity of high-pressure gas bottles, while limiting the downfalls associated with both methods. By exploiting a unique attribute of nanoporous materials—aerogel composite blanket in this case—in conjunction with unique packaging schemes, cryogenic fluid commodities such as hydrogen, methane, nitrogen, argon, and oxygen can be stored in a molecular surface adsorbed state at densities on par with liquid, at low to moderate pressure. With the application of heat, the fluid is then supplied as a gas, on-demand, to a downstream process. Several CFC module prototypes have been built and tested in a cylindrical geometry, but the salient and novel features of the technology are extensible to almost any shape, including conformal.

Extensive testing has been conducted to characterize seven different aerogel composite materials for potential use in CFC-based system designs using four different cryogens. Mass uptake and boil-off calorimetry data from this testing was used to establish various performance parameters for use in the material down-selection process for specific CFC module designs.

Three broad CFC application spaces have been identified that encompass a wide range of industries: CFC-Life, concerning life support applications requiring breathing oxygen; CFC-Cool applications, providing localized refrigeration power by passive means for shipping or storage; and CFC-Fuel applications, providing lightweight, energy-dense storage of fuels such as hydrogen or natural gas.

6. References

- [1] Boer J 1966 *The dynamical character of adsorption*, Oxford Clarendon Press
- [2] Williams, M K, Smith, T M, Fesmire, J E, Weiser, E S, and Sass, J P 2011 Foam / Aerogel Composite Materials for Thermal and Acoustic Insulation and Cryogen Storage, US Patent 7,977,411
- [3] Williams, M and Fesmire J 2016 Aerogel Hybrid Composite Materials: Designs and Testing for Multifunctional Applications, NASA Tech Briefs Webinar
- [4] Swanger A and Fesmire J 2019 Cryogenic flux capacitor for solid-state storage and on-demand supply of fluid commodities, US Patent Application 20190056064
- [5] Swanger A, Fesmire J and Fernando R 2019 Oxygen Storage Module with Physisorption Technology for Closed-Circuit Respirators, Cryogenic Engineering Conference, Hartford, CT, USA