

AUTOMATIC SHOWER CLEANER

Commercial/Domestic

2021

INSTALLATION/USER MANUAL



Contents

Installation/User Manual	1
Chapter 1: Introduction.....	3
Chapter 2: Installation.....	5
2.1 Human Detecting Sensor	6
Chapter 3: How to install the App.....	8
Chapter 4: Pairing up the App	10
Chapter 5: HOW the App WORKS.....	19
Chapter 6: How to set up the shower head Unit in Shower .	20
Chapter 7: How to use APP AND ITS FUNCTIONS.....	23
Chapter 8: BASE UNIT Installation	26
8.1 Connecting pipes to the servo valves.	27
8.2 Visual notifications from illuminating part in the Shower Head Unit and safety warnings	30
8.3 Safety Warnings	31
Chapter 9: Cleaning Liquids COSH Assessments.....	31
9.1 Shower Limescale remover	31
9.2 Shower sparkle.....	32
Chapter 10: Maintenance.....	34
10.1 How to power up the system	35
10.2 How to switch off the system.....	35
10.3 How to replace containers/cartridges	35

CHAPTER 1: INTRODUCTION

Please read the instructions and installation manual carefully before starting an installation process.

Special care should be taken when drilling ceiling to avoid hidden pipes or electric cables. Pipe connections must not be mismatched as it will result in failure to operate the ASC Unit.

The ASC Unit performance will be affected by temperature below 15C degree Celsius. For normal performance, the ASC Unit requires normal room temperature.

In case of installing ASC Shower Head Unit in different sized showers you will need to reprogram the unit to suit new shower dimensions (refer to the installation manual).

Please allow first test run of the ASC Unit upon completing installation for the system to fill up with liquids.

Note that the ASC Unit comes already pre-assembled to make the installation easier.

This Installation/ User Manual is designed for ASC Automatic Shower Cleaner Commercial and Domestic.

ASC Shower Cleaner consists of the following parts:

1) Flush to the ceiling cleaning **Shower Head Unit**:

Shower Head Unit parts (diag. 1):

a. **Rotary nuzzle**

b. **Main body**

c. Removable **illuminating part**

d. **Cover plate**

e. **Push fitting**

f. **N1 Precision electronic distribution valves** for each shower Head Unit in ASC Commercial only.

g. **N1 power supply adapter** for ASC Commercial Unit.

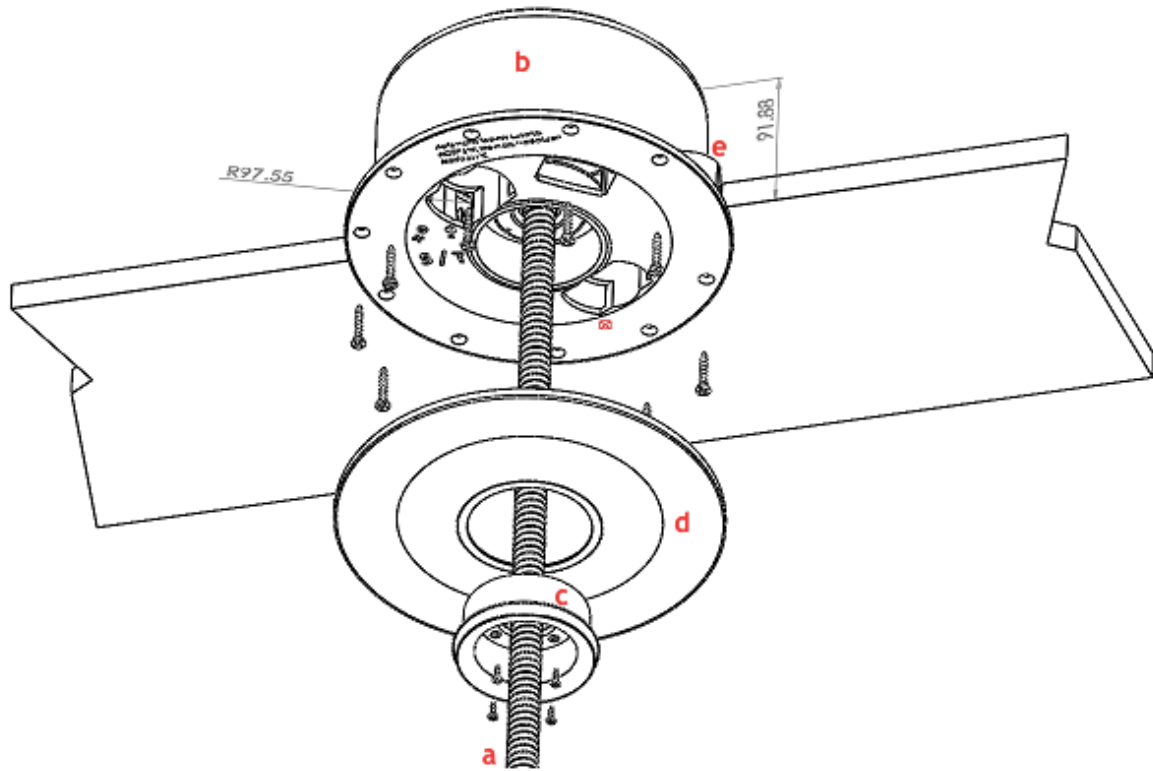

Diag. 1

2) Base Unit



ASC commercial base unit

Base Unit parts:

- a. N3 **liquid containers/Cartridges**, 5L each (for ASC Domestic Unit) or 20L each (for ASC Commercial Unit).
- b. N3 **removable Heads**, fixed on each container, for ASC Commercial Unit

Or N1 **removable Head** for all 3x5L Liquid container/Cartridges, for ASC Domestic Unit

c. N1 **power supply adapter**, for ASC Commercial Unit and ASC Domestic Unit

Before installing:

Ensure there is relevant size hole cut out in ceiling for the Shower Head Unit to be installed. The diameter of the hole is 195mm. Since the unit is concealed in the ceiling, the void between finish ceiling level and the upper side of concrete or any other structure needs to be no less than 115mm.

CHAPTER 2: INSTALLATION

Unpack the ASC Unit. Gently pull down **the rotary nozzle** from the ASC Shower Head Unit, so it will come down approximately 200mm. Please, don't force pulling it any further down. Install a pre-supplied tube into **the push fitting**. Push it firmly down, ensure it is well fitted in the push fitting and then connect the cables.

Note: Further information on how to install the tube using push fitting is widely available online.

Please note, that although the tube is fitted in **the push fitting** and the cables are connected, we suggest that one person holds the whole Shower Head Unit until the unit is fully installed into the ceiling. Don't rely on the connected cables and connected tube to hold the whole unit by it selves. If connected cables break off, operation of the unit might be affected.

Install **the main body** of the Shower Head Unit in the ceiling, use screws (drywall screws or any other suitable screws for metal surfaces). Ensure that the screw is not protruded from the surface of the main body. **Ensure the screw is not too tight to cause the crack or deformation to the surface of the main body (please refer to diag.2).**

The Shower Head Unit comes with human detector sensor which rests on **the main body** with following signs: S-for sensitivity; T-for timing; + and – showing the directions in which way to twist in order to increase (+) or decrease (-) range of the Sensitivity or the Timing (please refer to diagram 2). The default Sensitivity range of 1 meter radius is already set, meaning that the sensor will be able to detect a human within 1 meter radius and the unit will stop operating. We do not recommend making any modifications to the Timing range (T), as it may affect the performance of the unit.

However, if such necessity arises, then it should only be modified by the NGBR Ltd certified electrical engineers.

Apply **the cover plate to the main body**. Use the pre-supplied screws to attach the **illuminating part** to the cover plate to hold its position. Please note that illuminating part has groove which acts as a guide and the groove has to be aligned on the switch. Make sure that the switch is making a clear clicking noise so it's freely moving.

IMPORTANT- if it's not aligned properly, it may cause the unit's significant damage.

The rotary nuzzle at this stage will be tangled but it will be automatically retracted as soon as the unit is fully installed and powered up.

Note: Do not power up the unit until it's fully installed.

2.1 Human Detecting Sensor

Human detecting Sensor acts as an emergency stop, meaning that once the white light is on, human detection sensor is on, for 50 seconds and it will detect human movement within 1 meter radius (default distance) from the ASC Shower Head Unit.

In practice, this means the following: once the ASC is operational, red light will indicate readiness for cleaning process, **illuminating part** will turn red for 10 seconds, rotary nuzzle will drop down, after that light will turn white and start scanning for 50 seconds, at this point if there is anyone in shower, in a radius of 1m distance, human movement will be detected and the app will suspend cleaning cycle immediately, retracting rotary head and flushing Green LED light, indicating Off mode. If cycle was scheduled through the app, after suspension the unit won't start operating before next scheduled date and time. However, if you wish to restart the ASC before scheduled time, you can always do manual override just by pressing a start button in the app.

Please note: during the ASC Unit's operation every time white light is on, it indicates that human detection sensor is operational and stay clear of cubicle, till the ASC finished cleaning. If the process is disturbed during scanning, the ASC will stop operation and rotary nuzzle will retract. However, when the ASC is in the middle of the cycle and the rotary nuzzle is operational (it only takes 20 seconds for each cycle), red light is flushing and human detection sensor is not operational, meaning that the only way to stop the cycle is to press the emergency E button in the App. see the Pic 1. showing the E- Stop in the App.

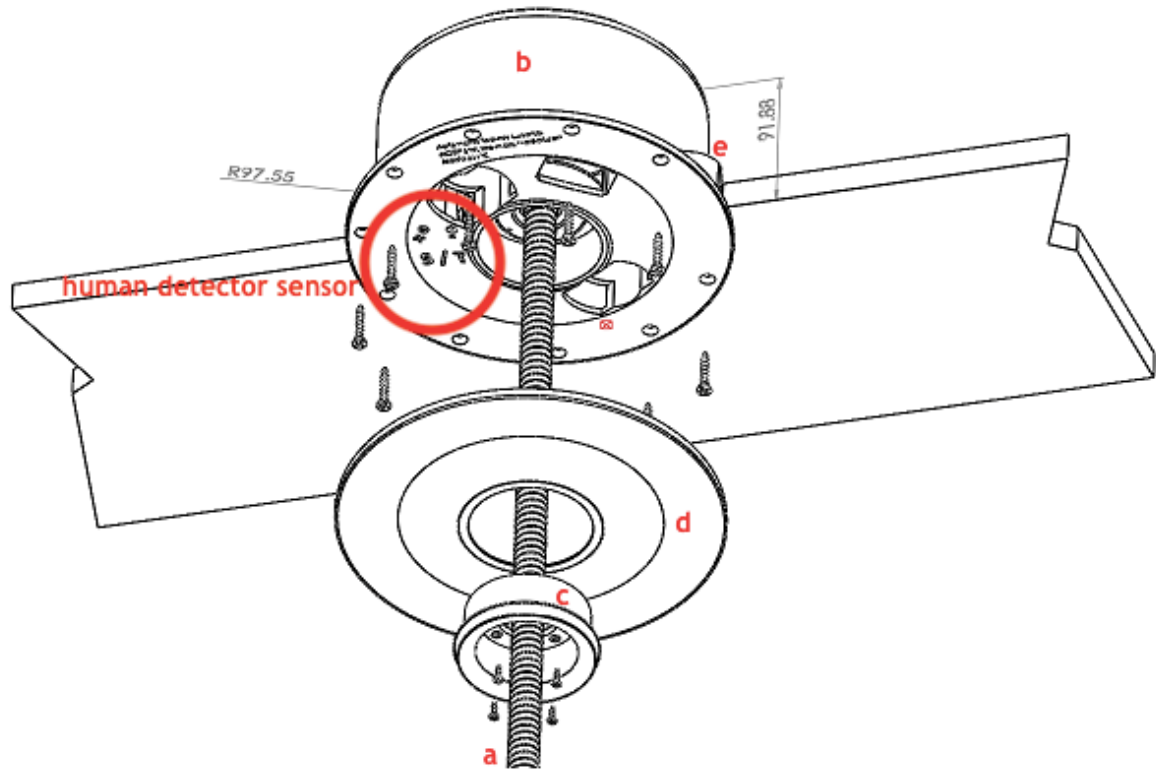

diag.2





HOME PAGE

Unit 1

Unit 2

Unit 3

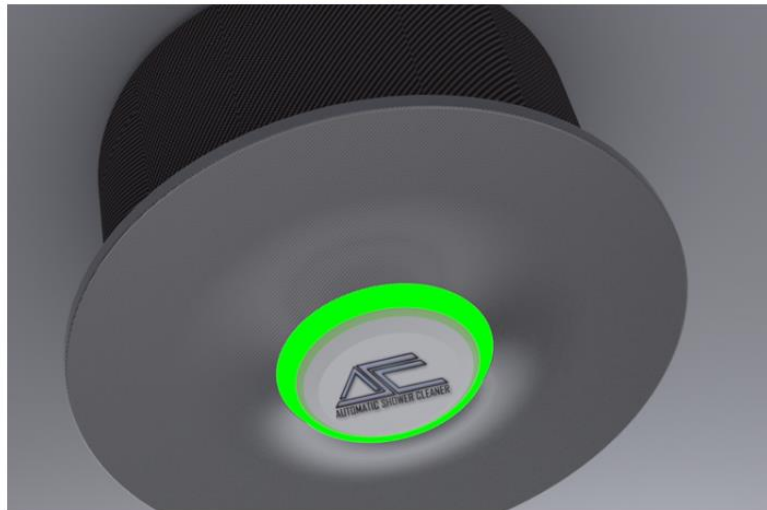

18:12:00

Mon, Tue, Wed, Thu, Fri, Sat, Sun

10:57:00

Mon, Tue, Wed, Thu, Fri, Sat, Sun

20:31:00

Mon, Tue, Wed, Thu, Fri, Sat, Sun

11:13:00

Mon, Tue, Wed, Thu, Fri, Sat, Sun



MANUAL START

E - STOP and RESET

E-STOP

please type "CLR" to clear the message board



Picture 1

CHAPTER 3: HOW TO INSTALL THE APP

- 1) Download the ASC C/D App (please see pic.2)
- 2) Sign up
- 3) Commence the pairing up the App with the ASC Unit

Important: Do not press Start till you set up the unit based on your shower enclose dimensions!



Picture 2

Find the ASC C/D App in the App store and download it. See the picture 2 of the App Logo.

After downloading the ASC C/D App sign up and follow the instructions (the AASC C/D App is free to download).

Please note: do not power up the ASC Unit Until the App is up and running, as you will not be able to control the unit. It is very important to have a strong WiFi signal!

Next step would be pairing up the ASC **Base Unit** to the ASC C/D App. You should do this by powering up **Base Unit**.

If the pairing up failed, make sure you are standing close to a **Base Unit**, you have a strong WiFi signal and reset the Base Unit by pressing the Reset button for 10 sec and enter the WiFi credentials again. The Reset Button in Commercial Units is located on Number 2 Base Unit (refer to pic.3). In domestic ASC Units, the Reset Button is located in the Base Unit (refer to pic.4).

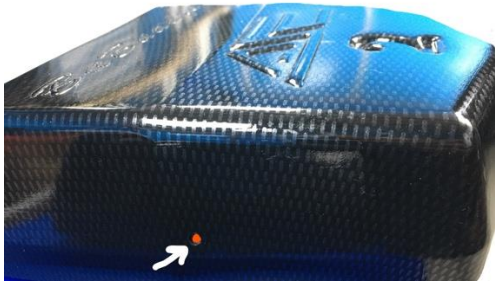

Picture 3

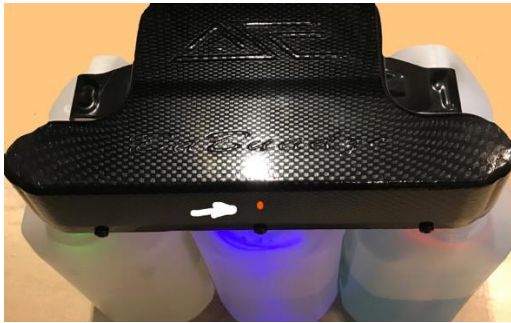

Picture 4

You go through the same steps if you want to enter a different WiFi connection.

CHAPTER 4: PAIRING UP THE APP

Open the ASC C/D Application in your smart phone or an iPad. On the screen, you will see “add the new device” or you can press on the right upper corner menu bar, it will show “add the new device” (refer to pic.5). The upper right corner menu is useful if you want to add more devices to your ASC C/D App.

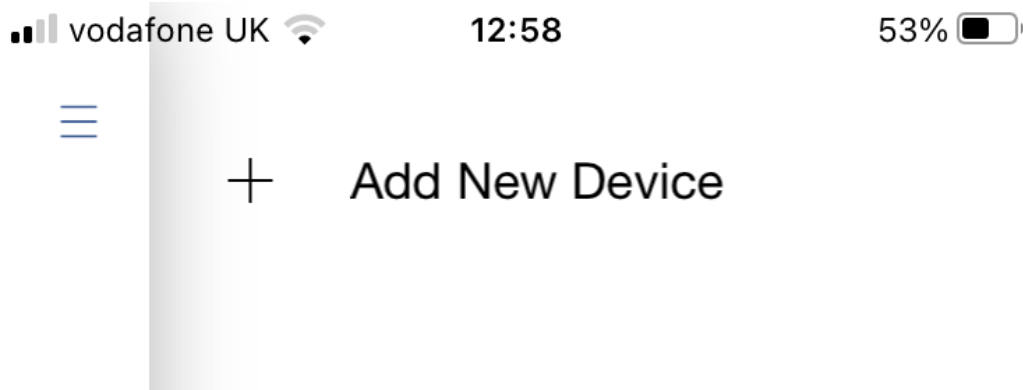

Picture 5

When pairing up the ASC C/D App with **the Base Unit** please make sure: a) you have a good WIFI connection, b) you are in a very close proximity to the Base Unit and c) the Base Unit is powered up, d) then press Ready button in the App (refer to pic. 6).



Check your Device



Power On your device and make sure that indicator is blinking



Ready

Picture 6

At the next page the ASC C/D App will ask for your permission to join your Wi-Fi Network and by pressing Join you prompt the connection process (pic.7).

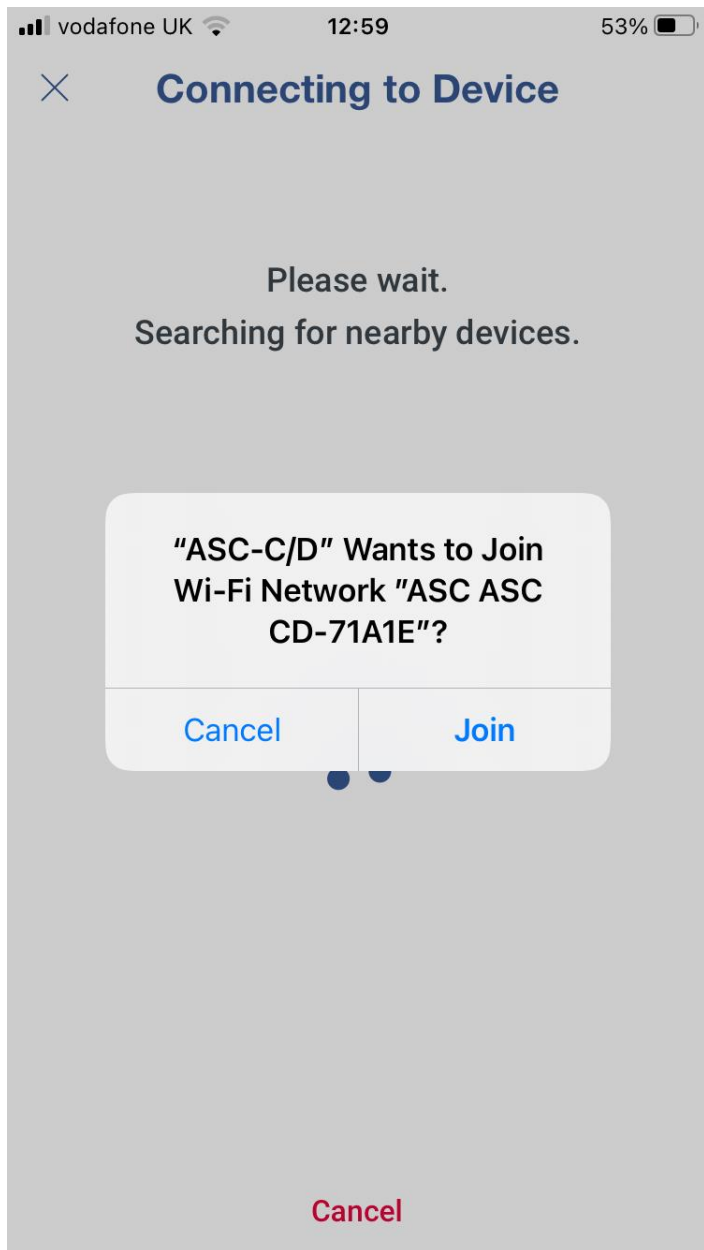

Picture 7

After that, choose your Wi-Fi Network and enter the password for your Wi-Fi and press Continue (picture 8).



WiFi Setup



Choose a 2.4 GHz Wi-Fi network your device will use

BTHub6-8S3F

Change

Password



Remember this network for other devices

IP address settings

Continue



Picture 8

It takes few minutes to configuring the device and once it's done you will be directed to the Device name page and connection status, once the connection is achieved, press Continue (picture 9) or at this stage you can change name of your device by pressing on the actual device name and enter the name/reference you want (picture 10) and number of corresponding rooms (for example block5 level 2 room number 4) and press continue (Picture 11).

Configuring Device



- Configuring WiFi
- Waiting for the device
- Final check

Cancel



Picture 9



Device Name



ASC ASC CD 71A1E connected!

NAME DEVICE

ASC ASC CD 71A1E



Continue

Picture 10



ASC-C/D



Block 8 Level 4



Block 2 level 5



Picture 11

The final page will show the status of the profile (if created), name of your device and its readiness to use, next- press Done (picture 12).

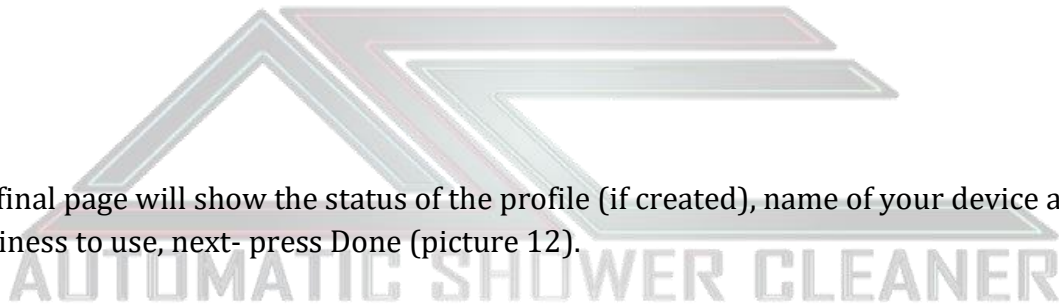



Device Name



Profile was successfully created

ASC ASC CD 71A1E is ready to use

You can view and edit this profile in the
Info section

Done



Picture 12

At that point, you have an option to add a new device if you wish, otherwise exit the App.

You can also change the name/ reference of your device at this point, by going to the individual device and pressing the upper right menu bar and change the device name and press the arrow to move to the next step (Picture 13).

At the same page, scroll down to Device Time zone and select the correct time Zone for your device (Picture 13).



Block 8 Level 4



Information

Timeline

MANUFACTURER

NGBR Ltd

STATUS

Online since 01:01 pm Nov 15



AUTOMATIONS

This device is not used in automations

FIRMWARE VERSION

 0.1.0

DEVICE TIMEZONE

Europe/London



HOTSPOT NAME

ASC ASC CD-71A1E



Picture 13

CHAPTER 5: HOW THE APP WORKS



Picture 14

On the first page, Home Page, (refer to pic.14) of the ASC C/D App, you will find three liquid tanks/cartridges with accordingly coloured columns of cleaning liquids. Because each cycle requires the equal amount of each liquid, if the liquid in one tank runs out, it will run out in other two as well. The app shows only the full or low level of the liquid, there is No indication for the middle level. Even though the App will not show you an exact amount of the cleaning liquids in the containers, it will remind you to fill it up when it runs out of liquid.

Please note that when the liquid runs out, even scheduled cycles will be suspended and the ASC Head unit will be showing Blue LED Light.

If you check the board on the Home Page, it will be informing your ASC Unit's activity, such as: Low level of liquid. You can clear the notification board by typing clr and pressing the enter/go button.

CHAPTER 6: HOW TO SET UP THE SHOWER HEAD UNIT IN SHOWER

Setting up the ASC Shower Head Unit

Unit 1

Important: Do not press Start till you set up the unit based on your shower enclosure dimensions!

* Setting up the Shower Head Unit Rotary nuzzle Heights

After installation, the ASC in the shower cubicle ceiling (described in Chapter 2) next step would be setting up **the rotary nuzzle** operation heights (top and bottom), ideal for your individual shower cubicle dimensions.

For this, the Base Unit Removable Heads must be removed from the liquid cartridges, resulting in the blue light flushing in Shower Head illuminating display.

In the ASC C/D App, under each Unit, there is L- Settings, Top-L, Bottom-L and L-Save Buttons. First, press L-Settings button, till LED lights sequence repeatedly flush, it indicates readiness for setting up the rotary nuzzle heights (refer to picture 15). Next, set up the rotary nuzzle top level, by pressing Top-L button, releasing the button once the desirable level is achieved (please add about 100mm extra length from top level of curtain/screen to avoid liquid splashing).

E - STOP and RESET

E - STOP

type "CLR" to clear the message board

```

steps below:
Step 1: Set Ceiling to top of the enclosure
Level (+ 100mm) dimension in mm.
Step 2: Set Ceiling to Shower base Level
(- 100mm) dimension in mm.
Step 3: Press L - SAVE button below to save
the sett levels or press E-STOP button to
reset system and start the setting up process
again
Step 4: finally if you are happy with the set
levels (considering above tolerance)then,
please press the E - STOP button to complete
the setup.
    
```

Type here

L - SETTINGS

↑s

Rotaitiin Speed

RS - 1

↑s

Rotaitiin Speed

RS + 1

Top-L

Rotation speed Reset

RS - Reset

L - save



Picture 15

Next, set up the rotary nozzle bottom level by pressing the Bottom-L button till the desirable length is achieved (please reduce the length by 100mm from the bottom level).

If you are not happy with the set up, then skip the L-Save button, press E-Stop, the rotary nozzle will retract (in its home position) and start the setting up process again.

If you are happy with the results, then press L-Save button, until red light is flushing in Shower Head illuminating display. Next, press the E- Stop button to return the Rotary nozzle in a start position.

After finishing the setting up process, return the **Base Unit's Removable Heads** to liquid cartridges, which will deactivate the service mode and then press Start button to test the system.

Now you are ready to press the Start button or Schedule the system.

Please note, once the ASC unit is operational, the shower curtains or shower screens must be closed fully, to avoid splashing!

The 1st run is a test run to make sure the system is full of the cleaning liquids.

In Commercial ASC case, you can set up the rest of the units same way.

- **The Rotary Nuzzle rotation speed and liquid coverage rate set up**

As soon as the first cycle starts if you are not happy with the Rotary Nuzzle speed and liquid coverage, you can use RS -1 and RS +1 buttons for adjusting the Rotary Nuzzle rotation speed and liquid coverage rate (please refer to picture 15). The ASC default mode rate will cope with 1m radius distance; however, RS +1 button can be used to increase the rate for bigger shower enclosures, or RS -1 to decrease the rate for smaller ones.

Please do not press RS -1, RS +1 buttons rapidly or continuously.

If you mess up the rotation system, you can always press RS Reset to go to the default settings and try again.

If you need further adjustment, please note that this can only be done when the ASC is operational, in other words during the washing cycles.

Please do not interfere with the Rotary Nuzzle rotation speed and liquid coverage rate adjustments unless necessary.



CHAPTER 7: HOW TO USE APP AND ITS FUNCTIONS

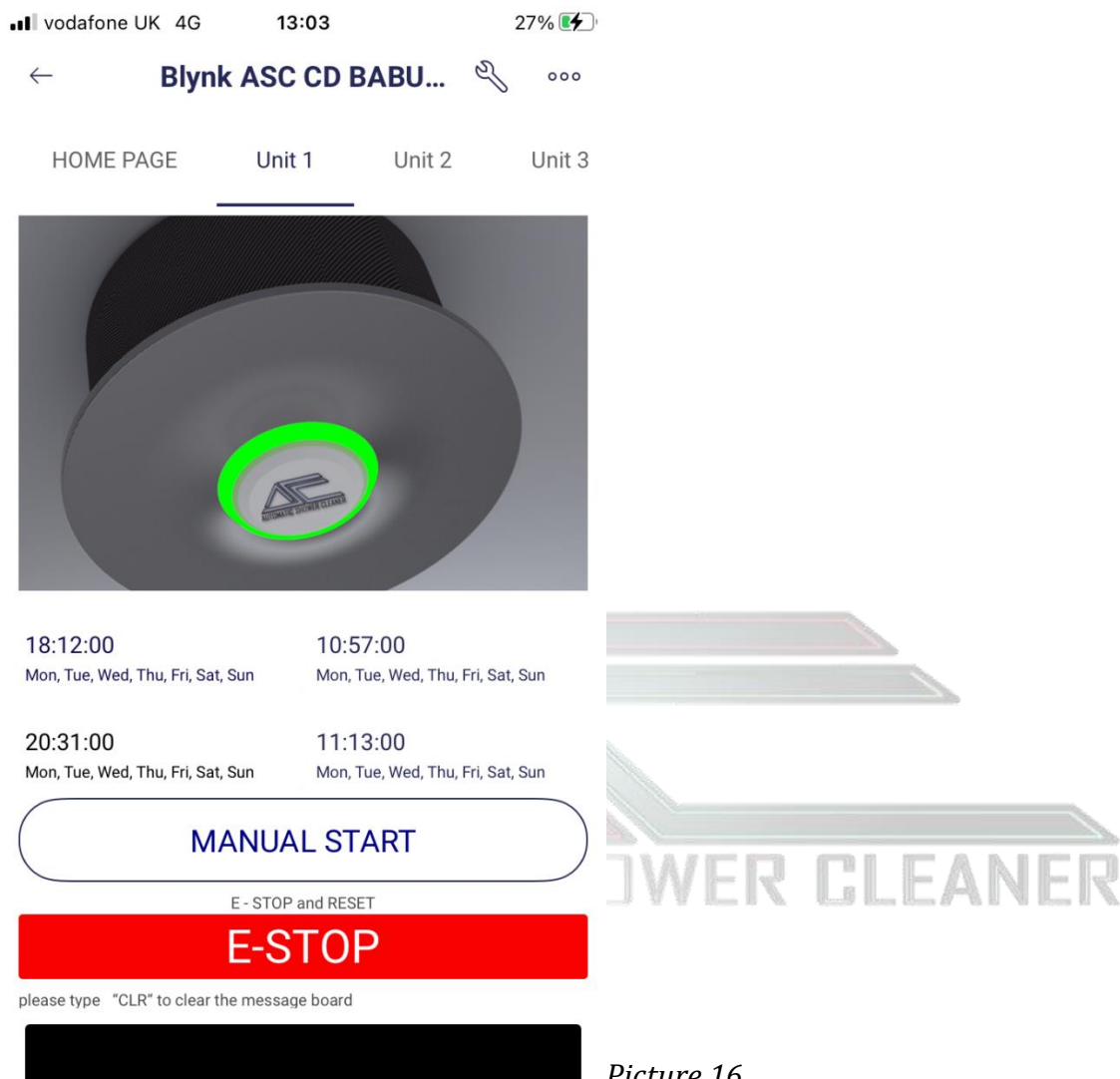

Picture 16

On each unit's page, under the picture of ASC Head Unit, you will find four options of scheduling the cycles, meaning that the maximum amount you can schedule to clean each shower is 4 times per day. The system is completely flexible.

For example, in Unit 1, if you wish to clean the shower twice every Monday, in the first option you can choose 1 pm Monday as a time for first cleaning and in the second option 2 pm Monday as a time for the second cleaning.

Alternatively, if you wish to clean the shower only once every Monday, in the first option you can choose 1pm Monday and make sure that none of other date and times are indicated in the remaining 3 options.

When you choose the date and time of the cleaning, the tab will be highlighted. If none are highlighted that indicates that none of the dates or times have been chosen so far.

PLEASE NOTE THAT IN ASC COMMERCIAL ALL FOUR DEVICES CANNOT BE SCHEDULED TO OPERATE AT THE SAME TIME, IT WILL NOT WORK! PLEASE ENSURE THAT THERE IS AT LEAST 10 MINUTES DIFFERENCE BETWEEN THE SCHEDULED CYCLES FOR EACH OF THE FOUR DEVICES.

Unit 2, Unit 3, Unit 4:

In all the remaining units, the layout and the options are exactly the same. What you will select as your option here, will apply to the operation of second, third or fourth device accordingly.

If you don't want to have any scheduled cleaning for any of the four rooms, you can still manually operate the ASC Unit by pressing the **Manual Start** Button on each page for any of 4 shower rooms.

Please allow reasonable time, about 20-30 min, to dry liquid surface tension droplets from a Rotary Nuzzle, before using a shower, after the ASC C/D finished cleaning.

Please refer the COSH assessment for safety precautions.

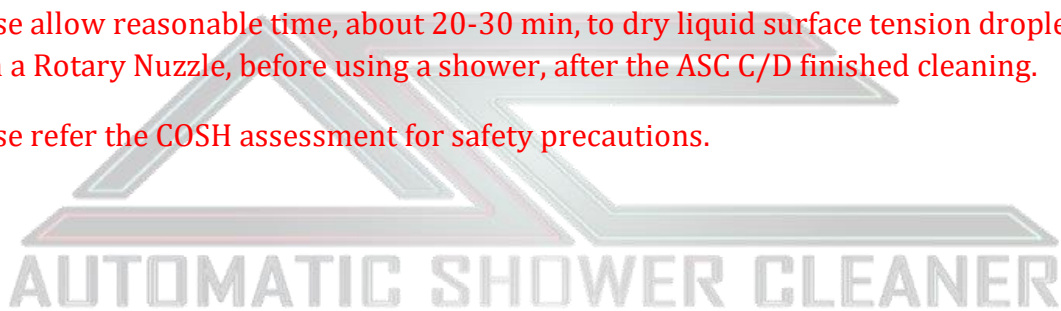

Last page – OPTIONS

If you want to disable all scheduled cycles, you can do that by pressing the **SYSTEM DISABLE** button on the last page – **OPTIONS** (please refer to picture 17);



ASC CD Master



Unit 2

Unit 3

Unit 4

OPTIONS



4^d

Disabel Days



System Disable

System Disable



[www. ascmarket.com](http://www.ascmarket.com)



Picture 17

Firstly, you'll see the slider which gives you the option to decide for how many days you wish to disable the system (picture 17).

Choose the days you want to disable the ASC system and then press the System **Disable Button**, to activate the feature. It will show the date of activation, the ASC system will be deactivated for maximum amount of seven days.

Please note that regardless the automation system is disabled or not, you can still use the Manual Start button to activate particular Unit if you choose to operate it manually.

More information can be found at www.ascmarket.com it will direct you to website.

CHAPTER 8: BASE UNIT INSTALLATION

How to connect the Base Unit to the ASC Shower Head Units.

Parts:

3 servo valves for each Shower Head Unit, in total 12 server valves for the ASC Commercial Unit.

1 power supply adapter for all 4 Shower Head Units

There are 2 options as to how the linkage of the pipes might look like according to the 2 different locations of the Shower Head Units, in ASC Commercial Unit.

Option 1

If four Shower Heads Units are located on one side of the three containers and the distance between the containers and the furthest located Shower Head Unit is max of 10 meters (the length of the pipe connecting the containers and the furthest Shower Head Unit is max 10 meters away).

Option 2

We call this the T option. The three containers are placed in the middle of the four Shower Head Units. So, 2 Shower Head Units are located on the one side of the

containers and other 2 are on the other side. The distance (pipe length) between the containers and the furthest Shower Head Unit on right hand side is max of 10 meters and the distance between the furthest Shower Head Unit on the left-hand side and the containers is max of 10 meters. Such a display allows the distance (pipe length) between the furthest Shower Head Unit on the right and the furthest Shower Head Unit on the left to be max of 20 meters.

For more than 2 Shower Head Units, we always recommend using the second (T) option. We also would encourage you to place the containers within the distance of less than 10 meters. The closer the containers to the furthest Shower Head Unit, better the performance, as the pressure is not undermined.

8.1 Connecting pipes to the servo valves.

Each container has different colour pipe connected to it. It is colour coded to avoid mixing up the different liquids, for example red, blue and black colour pipes. This is to avoid confusion, as which pipe is connected to which container. Each of these pipes run all the way to the furthest Shower Head Unit.

The pipes go up in the ceiling where the Shower Head Unit is incorporated. Each Shower Head Unit requires 3 servo valves, located approximately 1 meter away from the Shower Head Unit. This is same for every Shower Head Unit. DC 12V power supply for all 12 server valves will be provided by a single power adaptor (supplied).

We recommend placing the distribution connector reasonably close to the Shower Head Unit, so that the chances of two fluids mixing up are minimized.

For each Shower Head Unit N3 Servo valves (included in the kit) will have 3 pipe inlets (all colour coded, using any 3 different colour pipes, to avoid mix up), each pipe will be supplied with 3way connector valves.

N3 Servo valves will have 3 pipe outlets (also colour coded), all 3 connecting to only One 4 way connector valve (supplied) to deliver all 3 liquids to the Shower Head Unit.

We use the servo valves for the connection of the liquid supply pipes. There are 3 servo valves and 3 different coloured pipes for each Shower Head Unit (red, blue and black colour pipes used in our demo pictures (please refer to picture 18).

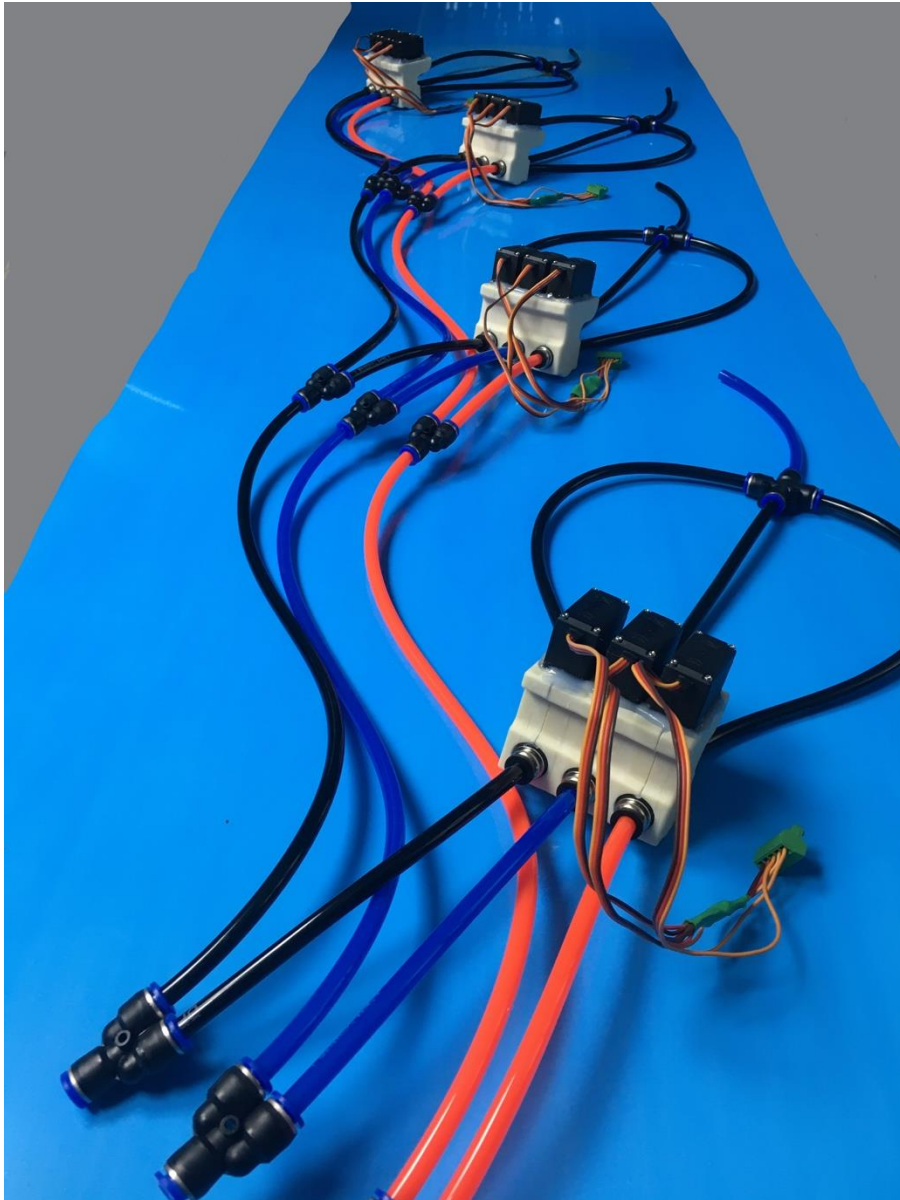

Picture 18

The Butterfly section must not be squashed or restricted in anyway, otherwise it will cause leakage.



Picture 19

How to connect pipes to the 3 outlet servo valves:

Cut the pipe at the point where it reaches the servo valve of the first Shower Head Unit. As we said earlier, we recommend the pipe to be shorter than 10 meters. All this in practice means that if, for example black pipe reached the valve at 2 meters, cut it there and connect it to the black pipe 3-way inlet, where one pipe goes directly to the servo, then connect the remaining 8 meters long pipe to the other outlet of the 3-way valve to bypass and continue to the inlet of second Shower Head Unit's valve. Next, connect red and blue pipes the same way to their dedicated 3 way valves. Now it's time to connect 3 coloured outlet pipes from servo valves to the one 4-way valve for each Shower Head Unit. This way valve will deliver all 3 liquids to the Shower Head Unit. 4 way valves

should be placed reasonably close to the Shower Head Units as illustrated in the picture 18.

For all three pumps and containers there is only one adapter (12 VDC) that needs to be permanently plugged in the 13-amp socket to power up the unit. Locate the containers in order according to the numbers (1,2,3) marked on top of the containers.

Please note that we strongly advise using appliance switch socket which will have on/off option.

Please, also ensure that all the cables connected to the valves and the connectors are separated from already existing cables of any type. We don't want to interfere with any existing cables and systems. For more information, please refer to electrical cable installation interfering guide.

Also ensure that every pipe in the push fittings is installed firmly according to push fitting installation guidance.

8.2 Visual notifications from illuminating part in the Shower Head Unit and safety warnings

ASC Shower Head Unit has two built in safety measures: visual notifications and human detection sensor.

Visual notifications

White Light- when flashing it indicates Human Detection sensor is operational.

Red light - when flashing indicates the system about to start operation, it gives you 5-6 seconds after turning the light red to close the door or curtain and move away from the shower cabin. After 5 seconds, White LED Light will start flashing, anyone still in the shower area or within the radius of 1 metre will be detected moving and ASC Unit will stop operating and LED light will turn green.

Green light - stand-by/ non-operational mode.

Blue light - indicates that the tanks have run out of liquid or when the system is in maintenance mode. It will not restart working until the liquid cartridges are replaced. At this stage, the ASC C/D App will also report that liquids run out.

8.3 Safety Warnings

Human Detecting sensor acts as an emergency stop, meaning that it will always detect human movement within 1 meter radius. In practice, this also means the following: if you have scheduled the cycle to start at 2pm through the App, at that time the illuminating part of the ASC Shower Head Unit will turn red for 10 seconds and then white for 50 seconds. It will start scanning for 50 seconds if there is anyone in the shower, if it detects human movement, the app will suspend the cycle immediately. Because the cycle was scheduled through the app, after the suspension the unit won't start operating before the next scheduled date and time. However, if you wish to restart the cycle before the scheduled time, you can always do manual override by pressing the start button in the app.

Please note that if the system operates on your chosen schedule it is essential that the shower cabin always remains closed. We recommend putting up a sign as a remainder to close the curtain or door of the shower /enclosure at all times.

CHAPTER 9: CLEANING LIQUIDS COSH ASSESSMENTS

9.1 Shower Limescale remover

Hazard Statements

H315 - Causes skin irritation

H319 - Causes serious eye irritation
Precautionary Statements P102 - Keep out of reach of children
P101 - If medical advice is needed, have product container or label at hand.

P305 + P351 + P338 - IF IN EYES: Rinse cautiously with water for several minutes. Remove contact lenses, if present and easy to do. Continue rinsing.

P302 + P352 - IF ON SKIN: Wash with plenty of water
P260 - Do not breathe spray. Do not mix with bleach or other cleaning products.

Description of first-aid measures

IF INHALED: Remove victim to fresh air and keep at rest in a position comfortable for breathing. Call a POISON CENTER or doctor/physician if exposed or you feel unwell.

IF ON SKIN: Wash with plenty of water and soap. Take off contaminated clothing and wash before reuse. If skin irritation or rash occurs: Get medical advice/attention. Discontinue use of product.

IF IN EYES: Rinse cautiously with water for several minutes. Remove contact lenses, if present and easy to do. Continue rinsing. Immediately call a POISON CENTER or doctor/physician.

IF SWALLOWED: Rinse mouth. DO NOT induce vomiting. Immediately call a POISON CENTER or doctor/physician. 4.2 Most important symptoms and effects, both acute and delayed Symptoms/injuries after inhalation Coughing. Sneezing. Headache. Drowsiness. Dizziness. Shortness of breath.

Symptoms/injuries after skin contact Redness. Swelling. Dryness. Itching.

Symptoms/injuries after eye contact Severe pain. Redness. Swelling. Blurred vision.

Symptoms/injuries after ingestion Oral mucosal or gastro-intestinal irritation. Nausea. Vomiting. Excessive secretion. Diarrhoea.

HANDLING AND STORAGE

Avoid contact with eyes.

Avoid contact with skin.

Do not eat, drink or smoke when using this product.

Do not handle until all safety precautions have been read and understood.

9.2 Shower sparkle

HAZARDS IDENTIFICATION:

Label elements S-phrase(s):

S2 Keep out of the reach of children.

S23 Do not breathe spray.

S26 in case of contact with eyes, rinse immediately with plenty of water and seek medical advice.

S51 Use only in well-ventilated areas.

Additional Labelling: As with any household product avoid prolonged skin contact with this product

Detergents regulations: Contains < 5% non-ionic surfactants ALSO CONTAINS perfume, Benzisothiazolinone

Other hazards: None identified

COMPOSITION/INFORMATION ON INGREDIENTS:

Hazardous components No dangerous ingredients according to Regulation (EC) No. 1907/2006

FIRST AID MEASURES:

Description of first aid measures Inhalation: No special requirements

Skin contact: Rinse with plenty of water. Get medical attention if irritation develops and persists.

Eye contact: Rinse with plenty of water. Get medical attention if irritation develops and persists.

Ingestion: Rinse mouth with water. If symptoms persist, call a physician.

Most important symptoms and effects, both acute and delayed

Eyes: May irritate eyes. No adverse effects expected when used as directed.

Skin effect: May irritate skin. No adverse effects expected when used as directed.

Skin effect: No adverse effects expected when used as directed.

Inhalation: No adverse effects expected when used as directed.

Ingestion: May cause abdominal discomfort. No adverse effects expected when used as directed.

Potential environmental effects: Not classified as Environmentally Hazardous according to Directive 1999/45/EC, as amended.

Indication of any immediate medical attention and special treatment See Description of first aid measures unless otherwise stated.

FIRE-FIGHTING MEASURES

Extinguishing media suitable: Use extinguishing measures that are appropriate to local circumstances and the surrounding environment.

HANDLING AND STORAGE

Handling Precautions for safe handling: For personal protection see section 8. Normal measures for preventive fire protection. Storage Conditions for safe storage, including any incompatibilities: Keep out of the reach of children. Do not freeze. No decomposition if stored and applied as directed. Specific end uses: Speciality Cleaner

EXPOSURE CONTROLS/PERSONAL PROTECTION

Control parameters Contains no substances with occupational exposure limit values. Exposure controls Respiratory protection: No personal respiratory protective equipment normally required.

Hand protection: Wear suitable gloves. The selected protective gloves have to satisfy the specifications of EU Directive 89/686/EEC and the standard EN 374 derived from it. Before removing gloves clean them with soap and water.

Eye protection: No special requirements.

Skin and body protection: Wash contaminated clothing before re-use.

Hygiene measures: Handle in accordance with good industrial hygiene and safety practice. Wash hands before breaks and at the end of workday

TOXICOLOGICAL INFORMATION

Information on toxicological effects Acute oral toxicity: LD50 estimated > 2,000 mg/kg May cause abdominal discomfort. Based on available data, the classification criteria are not met.

Acute inhalation toxicity: LC50 estimated > 5 mg/l Excessive exposure to spray mist, fog or vapour may cause respiratory irritation. Intentional misuse by deliberately concentrating and inhaling contents can be harmful or fatal. No adverse effects expected when used as directed. Based on available data, the classification criteria are not met.

Acute dermal toxicity: LD50 estimated > 2,000 mg/kg No adverse effects expected when used as directed. Based on available data, the classification criteria are not met.

Skin corrosion/irritation: May cause skin irritation in susceptible persons. Based on available data, the classification criteria are not met

CHAPTER 10: MAINTENANCE

10.1 How to power up the system

Before powering up the system very first time, all the installation procedures should be conducted, all cables should be connected in accordance with the diagrams, all push fittings need to be tightly adjusted to avoid leakage, power sockets need to be reasonably near-by so that there are no cables over stretched and there is a good connection.

We do not advise using temporary extensions the cable that supplies the power to the system needs to be plugged in at all times.

Ensure you power up the system in orderly manner:

- 1) Power up the **Base Unit** and ensure the ASC C/D App is connected to your device and Internet;
- 2) Open the ASC C/D App, after that, power up the **Shower Head Units** in shower, too.

Note: make sure all shower cabins are closed and no one is in the cabin and only then you can proceed with the shower cleaning cycle.

10.2 How to switch off the system

How to restart/switch off the system in orderly manner:

Switch off the **Head Units**;

Switch off the **Base Unit**.

Cartridge/ liquid replacements don't require the **Head** or **Base units** to be switched off.

10.3 How to replace containers/cartridges

Each number or each colour represents different type of liquids. For example, the red/orange coloured container (N1) will always have only cleaning detergent and descaling liquid in it. The blue coloured container (N2) is only for tap water. The green coloured (N3) container will always include disinfecting and polishing agent.

Please, ensure when changing the cartridges (liquids) that the colours match with the type of liquid that are in their specified containers.

Make sure you fill up N2 container/cartridge with tap water only.

For N1 and N3 container/cartridges remove the cup of the new container and put it aside. Place the new container close to the empty container/cartridge.

Separate empty container with the Removable Head, which rests upon it. Grab the Removable Head with both hands and lift up gently and evenly. **DO NOT TURN IT UPSIDE DOWN! IT MAY CAUSE DAMAGE!**

Put the Removable Head on the new container. Adjust it, so it fits firmly. Take the removed cup and put it on the empty container.

Please, ensure that when replacing the containers, you clean some deposits of scale residue on the tip of the electronic sensor, attached to the pipe in the container. **CLEAN IT GENTLY, WITHOUT DAMAGING IT.**

WARNINGS:

If the warranty void stickers on the units are removed, the warranties are invalidated.

Please, take careful approach when completing the maintenance work for the product.

Rotary nozzle is a permanently sealed part of the unit, so please don't attempt opening up the part as it will also invalidate the warranty.

More information can be found at www.ascmarket.com

Please send us an email to info@ngbr.co.uk if you have questions or are experiencing any issue with the product. We will be happy to help.

We will not be responsible or liable in any manner for the user generated harm or the result that may arise from the negligent use on your side.

GENERAL TERMS

The ASC unit only comes with a 1-year warranty. No other liquids should be used in the ASC, or it will void the warranty. Refunds within only 10 days after delivery. Upon refund buyers are liable for payments for packaging and delivery. Unit complies UK and EU standards, check your country regulations before purchase. The Product seal cannot be broken, or it will void warranty. The Product cannot be promoted under other name or company. The Unit must be installed as per recommended manner and specialist contractor or voids warranty.

