



---

# GM6DX – 2 PHASED VERTICAL ARRAY SYSTEM

---

End fire and Broadside - Instruction Manual



FEBRUARY 5, 2021

GM6DX

[www.hamcables.co.uk](http://www.hamcables.co.uk)



Thanks for purchasing the 2 phased vertical array control system. This control switch unit and relay box allows you to use 2 vertical antennas in a phased set up - this is based similar to the **Christman phasing model**. The antenna will switch direction of transmit and receive from left to right (directional) and act as a dipole in the up and down direction.

Below is an image of the basic set up of the antenna system;

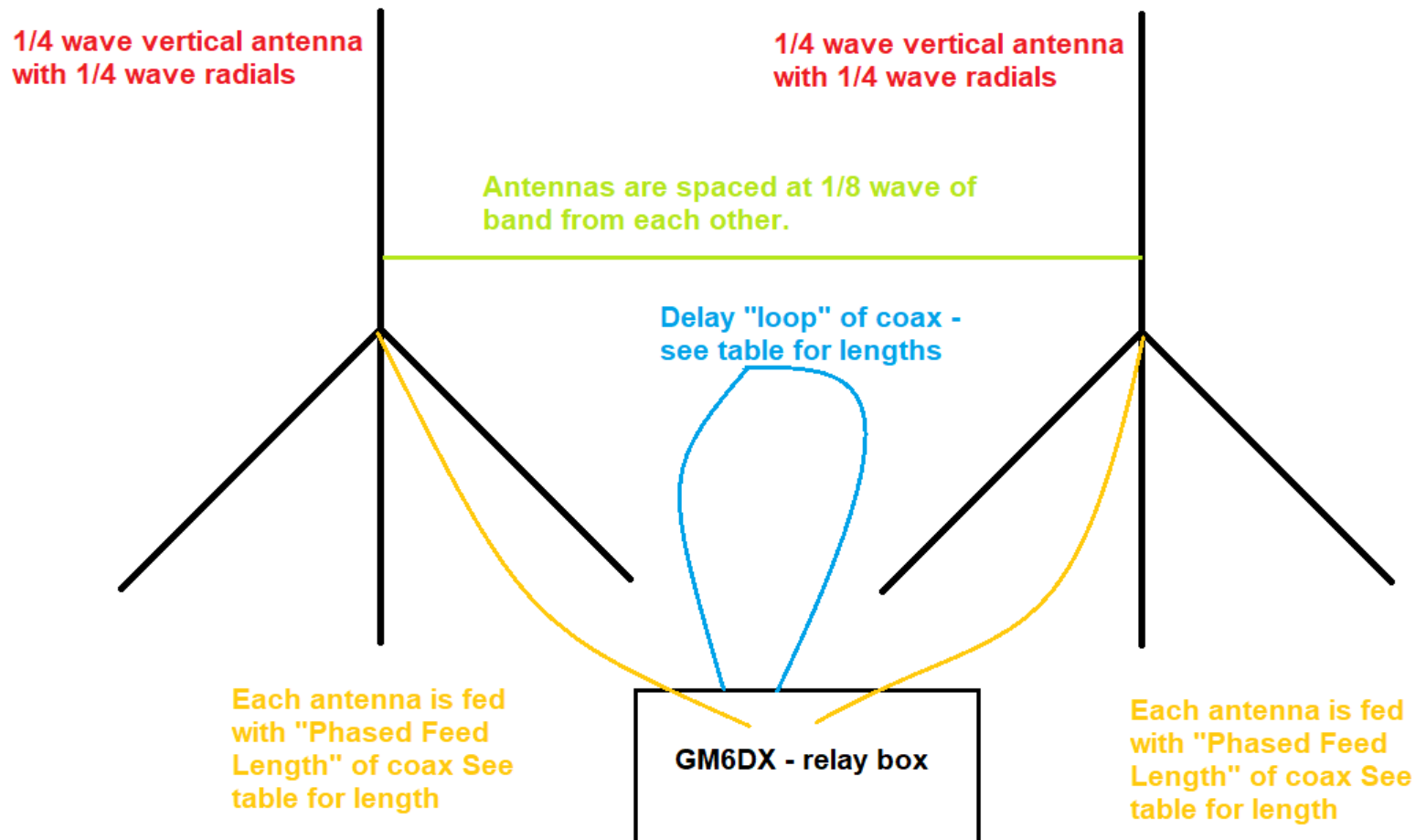

Here you have 2 x  $\frac{1}{4}$  wave vertical antennas for the band in use - it is recommended that you use a  $\frac{1}{4}$  wave vertical antenna with an elevated feed-point and 4 x  $\frac{1}{4}$  wave radials. When tuning your vertical antennas please use the **"Phased Feed Length"** of coax from the table below, during tuning.

BAND	PHASED DELAY LENGTH RG-213u	PHASED DELAY LENGTH Messi&Paoloni Ultraflex 7	PHASED FEED LENGTH RG-213u	PHASED FEED LENGTH Messi&Paoloni Ultraflex 7
10m	75.26cm (0.7526m)	94.64cm (0.9464m)	3.029m	3.810m
12m	89.37cm (0.8937m)	1.123m	3.597m	4.524m
15m	1.011m	1.272m	4.073m	5.122m
17m	1.185m	1.490m	4.770m	5.999m
20m	1.513m	1.902m	6.091m	7.660m
30m	2.123m	2.670m	8.549m	10.751m
40m	3.021m	3.799m	12.161m	15.29m
80m	5.797m	7.290m	23.337m	29.349m
160m	11.289m	14.197m	45.447m	57.153m

Lengths are from tip of p1259 plug to tip of p1259 plug

I recommend you use Messi & Paoloni Ultraflex 7 but I have included the lengths of RG213-U as an alternative. For each band of operation you will need;

**2 x** Phased Feed Length of coax

**1 x** Phased Delay Length of coax

One vertical antenna is fed with **1 x length of Phased Feed Length** of coax - this connects from port A on the relay box.

Another length of Phased Feed Length of coax is connected **to port B** on the relay box to the second vertical.

So both antennas will be connected to the relay box **via Port A and Port B**.

The Delay Phased Length of coax is a loop of coax which delays the signal going from one vertical to the other - one end of this loop gets connected to **Port 1** and the other end to **Port 2** on the relay box.

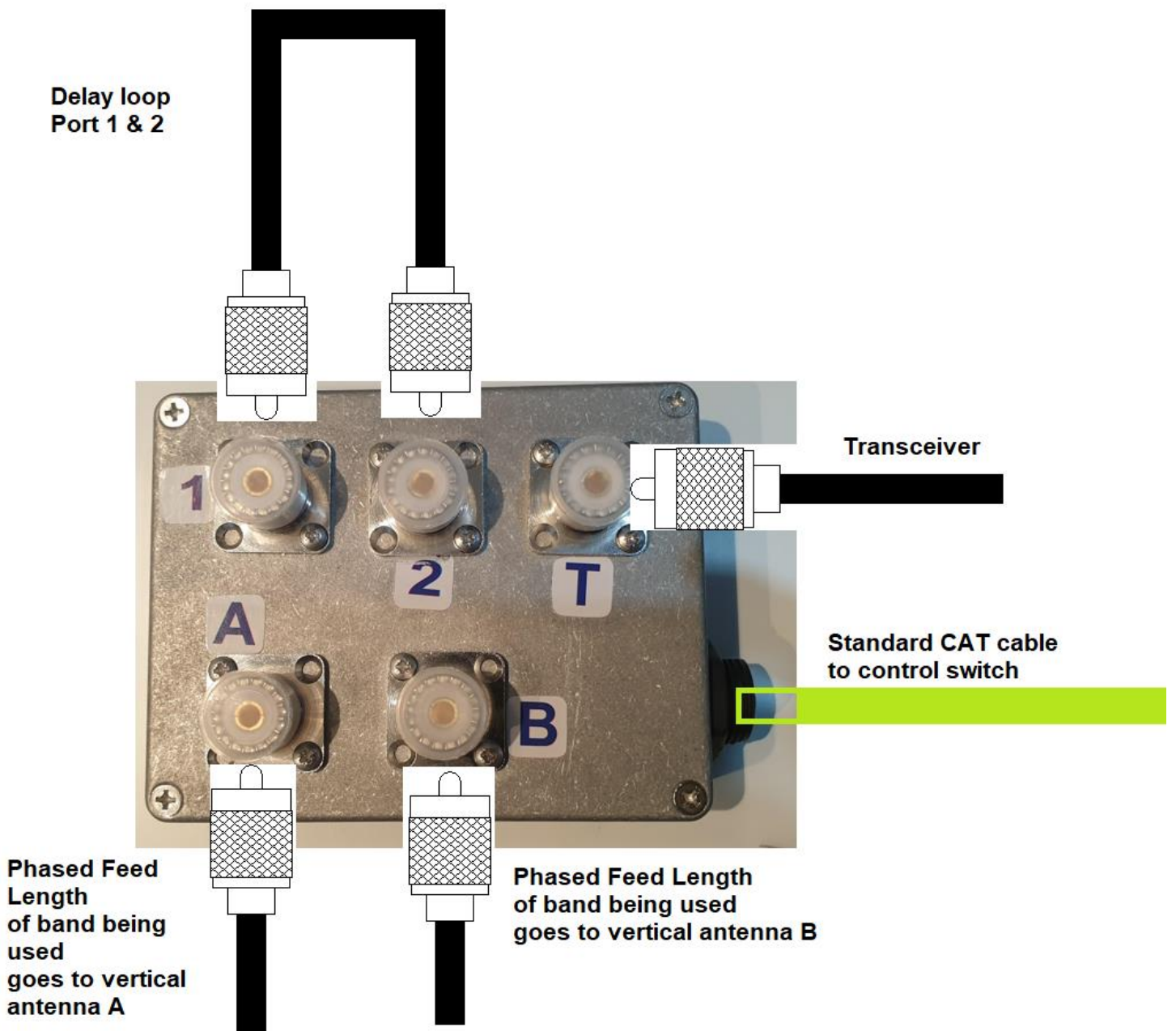

Here you can see the layout of connections, of the relay box. It is recommended that you cover the pl259 plugs with tape as well as the CAT socket in order to prevent water ingress.



Standard CAT cable allows control of the relays from the relay box to the control switch box

The relay box is controlled via "switch Control Unit". The rear of the unit has a RJ45 socket to allow the use of standard cat cable to connect to the relay box.



A 2.5 x 5.5mm DC jack Centre positive is used to feed the system with DC voltage can be 12v - 15v DC.

On the front of the switch control unit you will see a switch, switching direction of transmit / receive from Right (*directional*) then up and down (*dipole*) then Left (*directional*). The direction in which the antenna is beaming will be shown by the LED on the front panel.

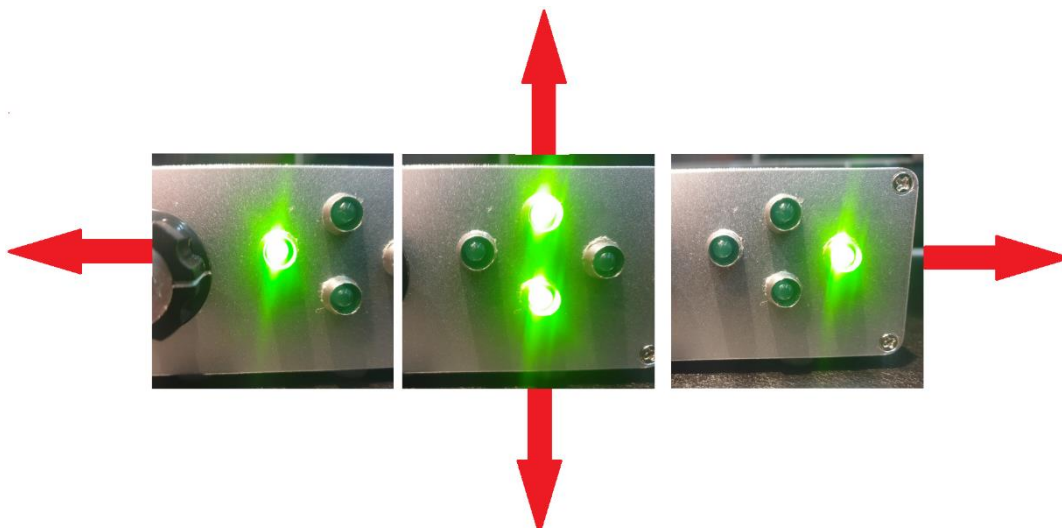
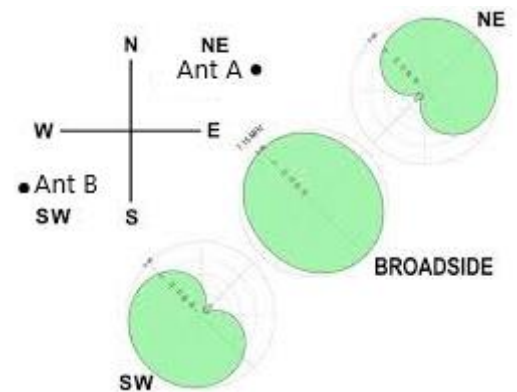

The relay box and switch control unit housing are made from aluminium. The switch unit has been tested using up to 100m CAT cable where there has been little voltage drop along that run, however you should conduct tests or use heavier gauge wire if you are experiencing voltage drops because of the length of run between the control switch unit and relay box.

The unit can take 3KW peak and 1.5kW continual key down.

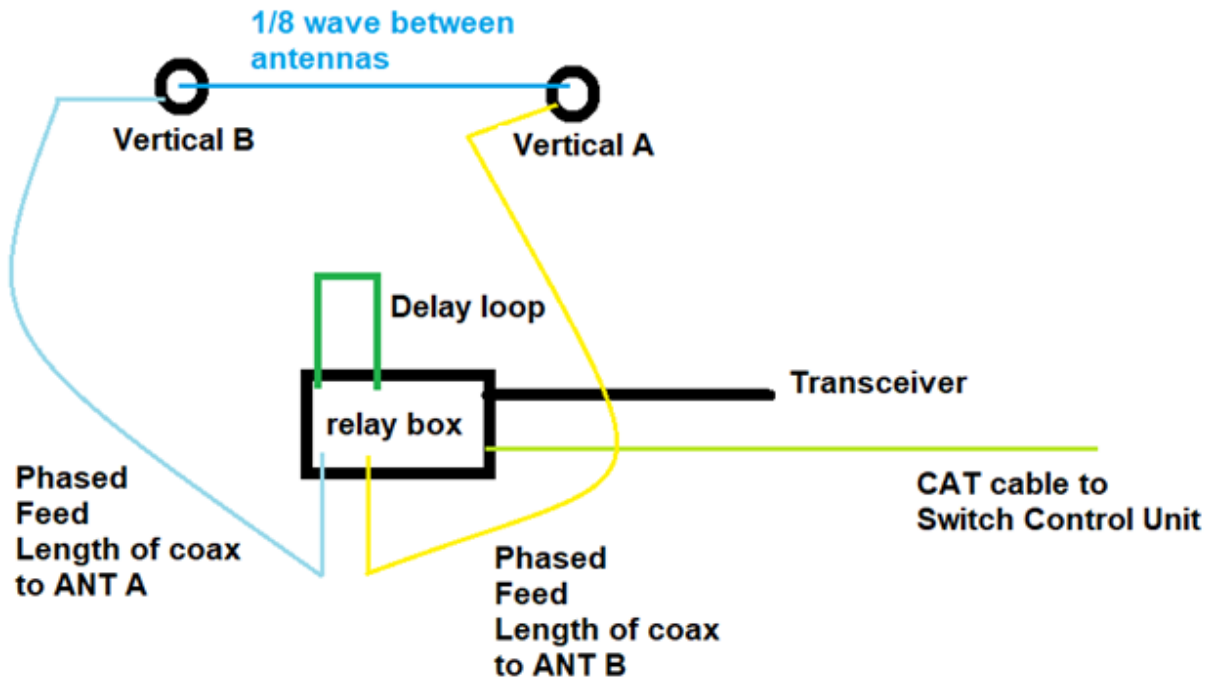

To save you some time, I have detailed the 1/8 wave spacing **between antenna A and antenna B** for each band as follows:

- 10m - 1.31m
- 12m - 1.56m
- 15m - 1.76m
- 17m - 2.07m
- 20m - 2.64m
- 30m - 3.71m
- 40m - 5.28m
- 80m - 10.13m
- 160m - 19.73m

**ANY question please ask**

**73 GM6DX**