

# 17U FLOOR STANDING INDOOR DATA RACKS



Note: Product image is for representation only, original product may vary in color and design



## PRODUCT OVERVIEW

- AANAGH Indoor 17U floor standing racks are made with high-quality rolled iron sheets and are sturdily built.
- Used for Rackmount Servers, Tower Servers, Computer, Networking Panels, VOIP, Audio Visual Equipments, TV Radio Broadcasting Equipments, CCTV DVR, Testing Equipments and other 19" Electronic and Telecom Equipments.
- The front door comes with a high-quality toughened glass/metal perforated door with a locking system.
- It goes through a strict anti-rusting process to ensure durability
- These 17U rack is made from a dominant quality, high gauge sheet metal(iron) and powder coating process
- Designed carefully to ensure easy installation and assembling
- Rounded edges to ensure customer's safety during installation
- Collapsible for easy transportation and cost-saving
- Available in different depth variants
- Wide range of accessories to choose from
- Available in light gray or black color

## FEATURES

- Conforms to DIN 41494 OR equivalent ISO Standards
- Adjustable 19" equipment mounting verticals provide better mounting flexibility and maximize the usable mounting space
- Depth adjustable mounting slots
- Precision engineering capabilities and the best efficient software configuration product technology provide the best product quality and fastest delivery in the industry
- Top and bottom Panel with ventilation and cable entry facility
- Provision to mount the cooling fans on the top panel
- Powder-coated finish with Seven Tank pretreatment process meeting all industry standards
- Grounding and Bonding Options. 100% assured compatibility with all types of equipment conforming to DIN 41494 (General industrial standard for equipments)
- Loadbearing capacity up to 100 kg

## SPECIFICATIONS

TECHNICAL SPECIFICATIONS	
Model	AFO-17IGF-AA
Brand	AANAGH
Size	600 x 600 x 829
Product Material	CRCA & GI
Product Mount	Floor Standing
Front door	Toughened Glass / Perforated
Warranty	3 Year
Key Lock	Yes
Rear Panel	Fixed / Door (Glass / Perforated)
Construction	Collapsible
Cable Entry Cut	Top / Bottom
Cooling Options	Provision for two / four fan at top panel
Load Bearing Capacity	Up to 100kg +-10%
Color	Light Grey Powder Coated ( RAL 7035)
Leveling Bolts	Yes
Country of Origin	Proudly India
APPLICATION USAGE	
Surveillance	Yes
Data Rack	Yes
AV Rack	Yes
Low Depth Servers	Yes
AVAILABLE ACCESSORIES (Optional)	
Cable Manager	Horizontal / Vertical (Metal / PVC)
PDU	6 Socket 5 & 15 AMP Horizontal
Cooling Fan	Yes 2 fan / 4 fan assembly
Fix Shelf / Cantilever Shelf	Yes
Hardware Kit	Yes
Optional Color	RAL 9005 Black
Server Rails	Traditional / Tool less rails
Earthing Kit	Yes
Castor Wheels	Yes
CERTIFICATIONS	
ISO-9001	Yes
DPIIT	Yes
CE	Yes
RoHS	Yes
AVAILABLE SIZES	
AFO-17IGF-AB	600 x 800 x 829
AFO-17IGF-AC	600 x 1000 x 829
AFO-17IGF-AD	800 x 800 x 829
AFO-17IGF-AE	800 x 1000 x 829

Note: All type of design, size and color customization is acceptable at extra cost

# STRUCTURAL DIAGRAM

**Main Structure:  
(600mm Width)**

- 1 Cable entrance
- 2 Perforated rear door(dual open)
- 3 Mounting profile
- 4 Nine-folded profile
- 5 Mounting angle
- 6 Supporting corner
- 7 Castor
- 8 Top cover
- 9 Fan tray
- 10 Side panel
- 11 Perforated front door(Single open)

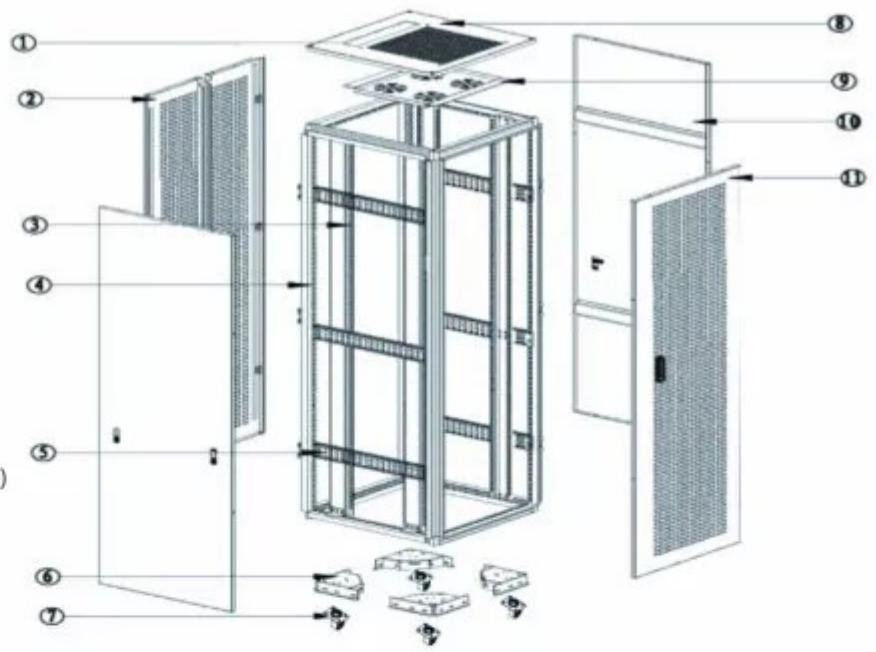

**Main Dimension:**

