

ShoMe Spring ShoCase

Showmanship Sweepstakes

Show Date: 05-06-2022

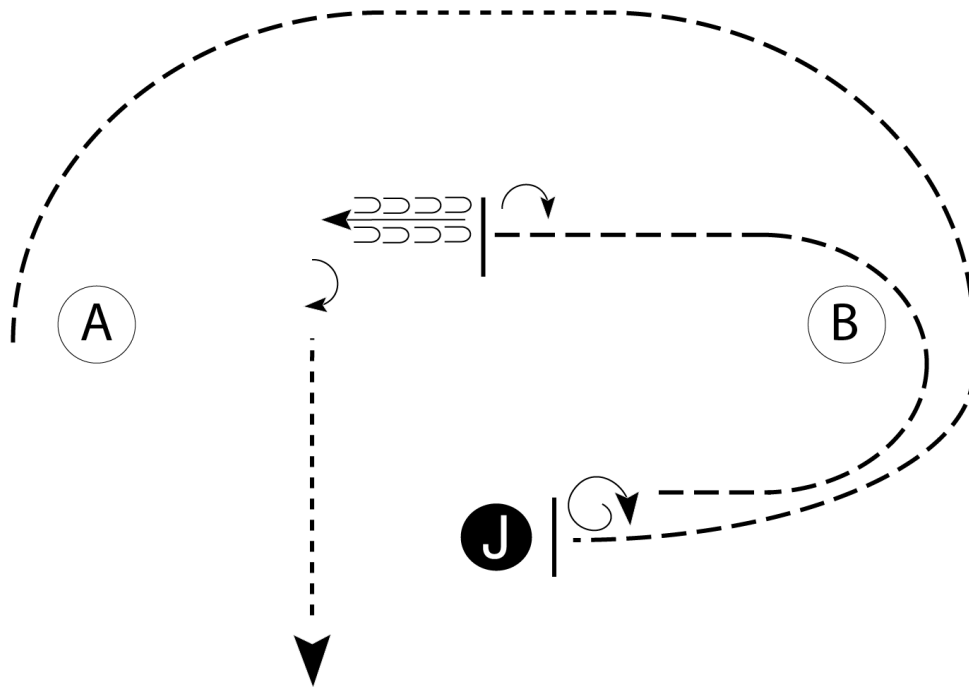

Be ready at A.

1. Trot an arc to the right.
2. At the top of the arc, walk two strides.
3. Trot in a half circle and straight to Judge.
4. Stop and set up for inspection.
5. When dismissed, perform a 1 1/2 turn.
6. Trot around B as shown. When even with Judge, stop and perform a 1/2 turn.
7. Back approximately one horse length.
8. Turn 1/4 turn and walk straight away to exit.

Follow the instructions of your ring steward.

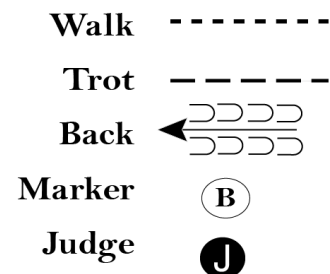

[S/3-46]

Pattern Provided by:

The Horses

ShoMe Spring ShoCase

Hands Free Showmanship Challenge

Show Date: 05-06-2022

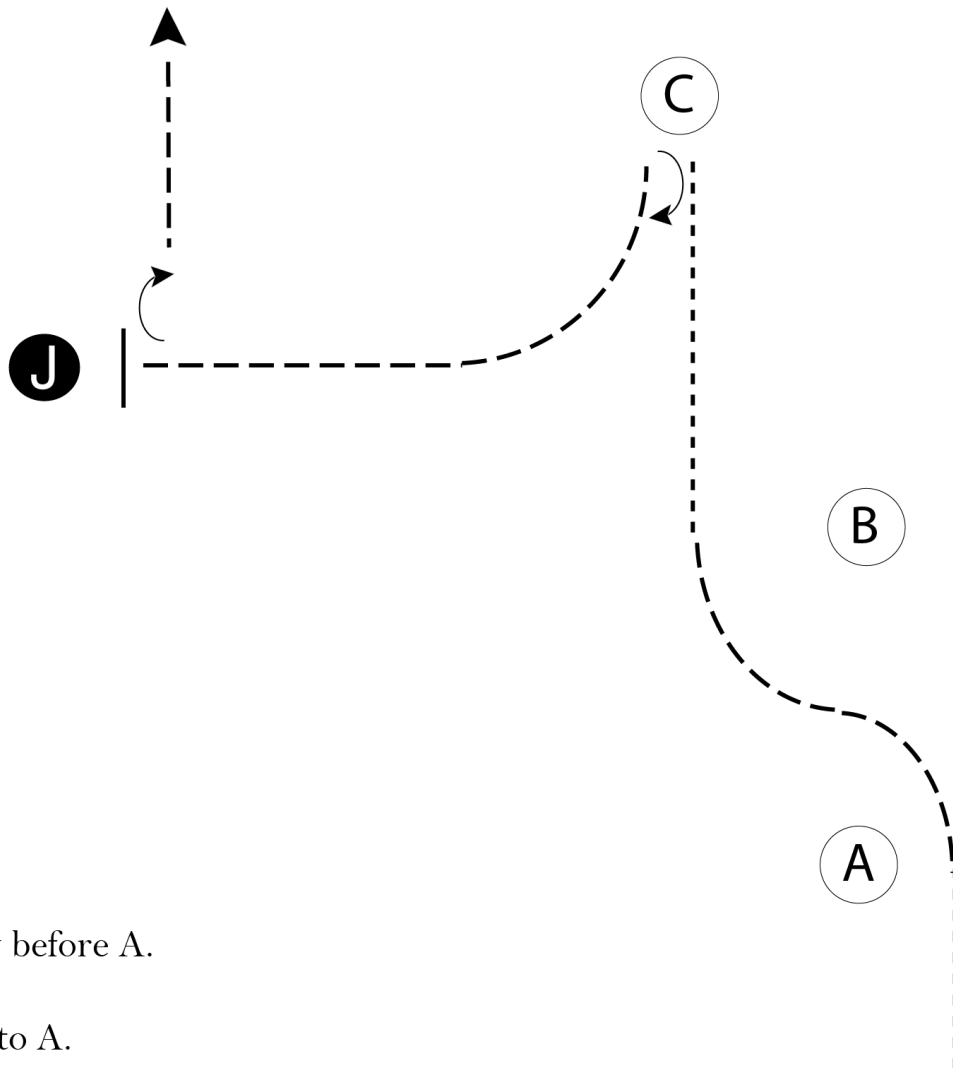

Be ready before A.

1. Walk to A.
2. Trot to B as shown.
3. Walk to C.
4. Perform a 180 degree turn and trot to Judge.
5. Perform a 1/4 turn and set up for inspection.
6. When dismissed, exit at a trot.

Follow the instructions of your ring steward.

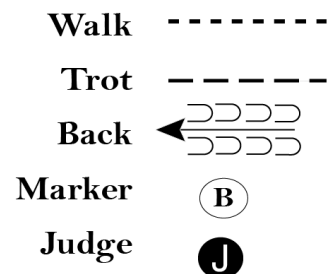

[S/1-91]

Pattern Provided by:

The Horses

w w w . H o r s e S h o w P a t t e r n s . c o m

w w w . H o r s e S h o w P a t t e r n s . c o m

ShoMe Spring ShoCase

Showmanship Classes 38-40

Show Date: 05-06-2022

w w w . H o r s e S h o w P a t t e r n s . c o m

w w w . H o r s e S h o w P a t t e r n s . c o m

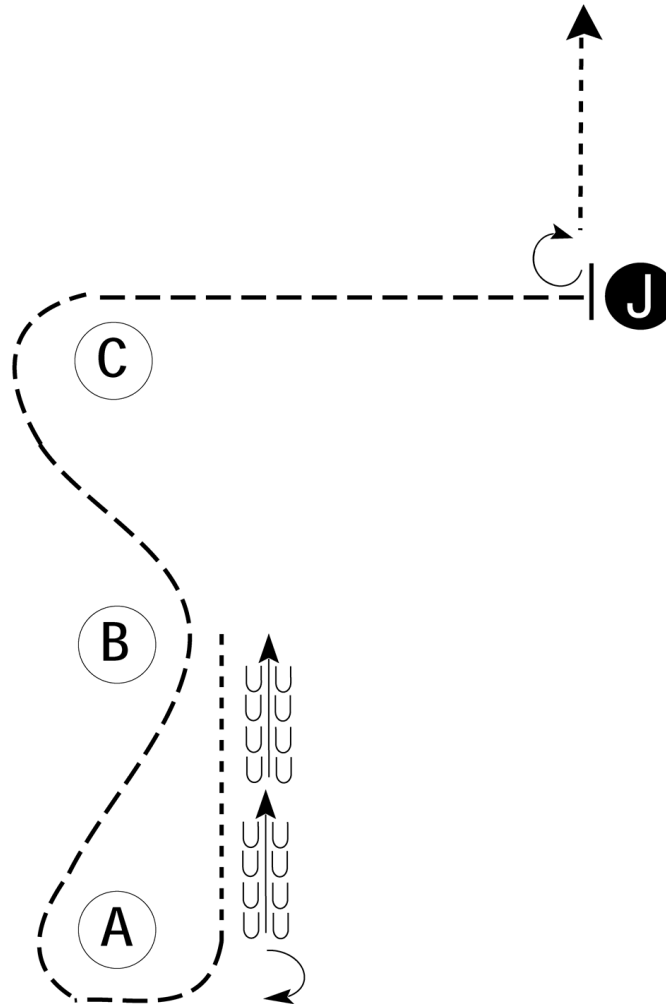

Be ready at A.

1. When acknowledged, perform a 180 degree turn.
2. Back to B.
3. Walk to A.
4. Trot around A, around B, around C and straight to judge.
5. Stop and set up for inspection.
6. When dismissed, perform a 270 degree turn and walk away from judge.

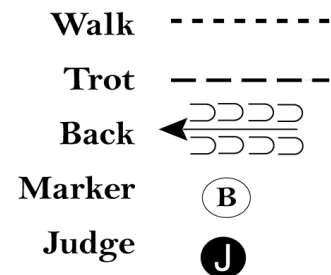

Follow the directions of the ring steward.

[S/3-59]

Pattern Provided by:

The Horses

ShoMe Spring ShoCase

Showmanship Classes 41-42, 45-46

Show Date: 05-06-2022

w w w . H o r s e S h o w P a t t e r n s . c o m

w w w . H o r s e S h o w P a t t e r n s . c o m

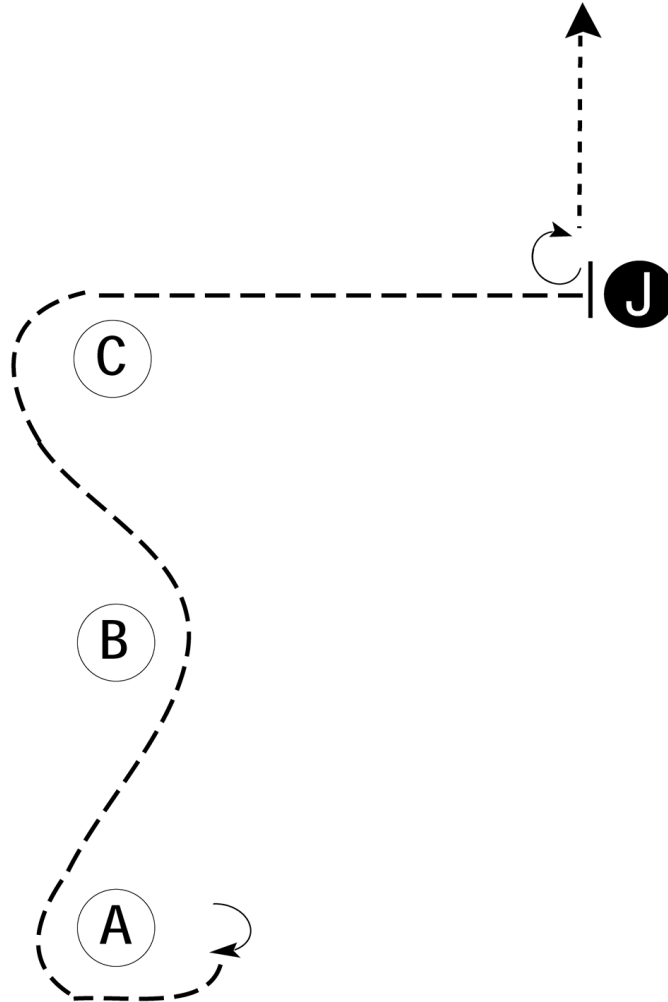

Be ready at A.

1. When acknowledged, perform a 180 degree turn.
2. Trot around A, around B, around C and straight to judge.
3. Stop and set up for inspection.
4. When dismissed, perform a 270 degree turn and walk away from judge.

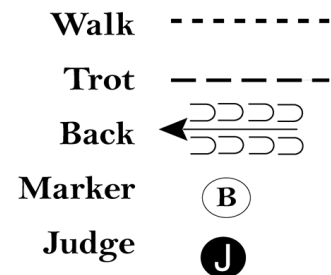

Follow the directions of the ring steward.

[S/2-59]

Pattern Provided by:
The Horses

Pee Wee—Leadline Showmanship 43-44

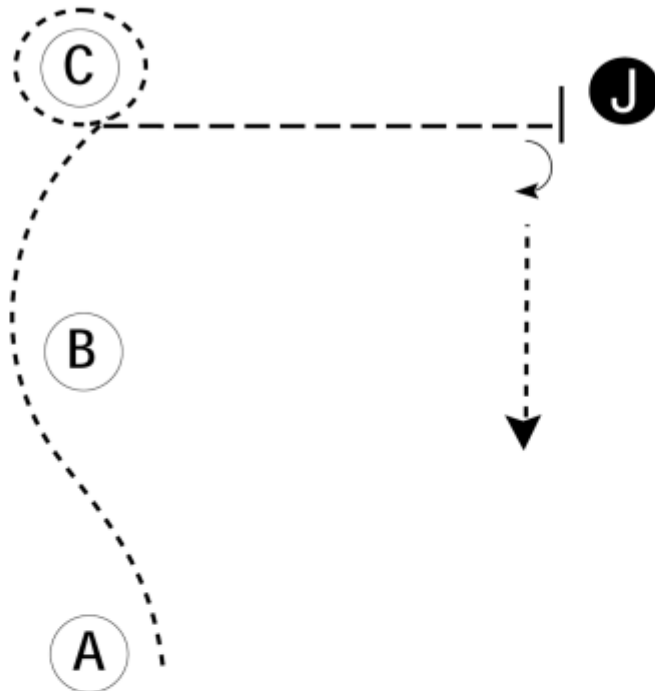

Be ready at A.

1. When acknowledged, walk from A, around B and to C.
2. Walk a tight circle around C.
3. Walk to judge.
4. Stop and set up for inspection.
5. When dismissed, perform a 90 degree turn and walk away from judge.

Follow the directions of your ring steward.

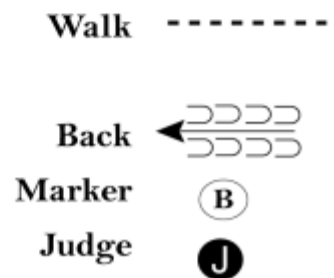

ShoMe Spring ShoCase

Showmanship Classes 47-51

Show Date: 05-06-2022

w w w . H o r s e S h o w P a t t e r n s . c o m

w w w . H o r s e S h o w P a t t e r n s . c o m

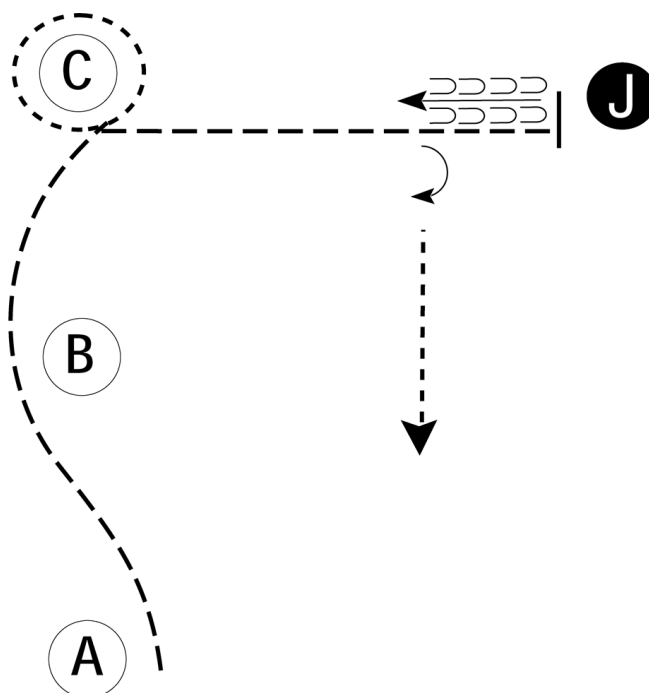

Be ready at A.

1. When acknowledged, trot from A, around B and to C.
2. Walk a tight circle around C.
3. Trot to judge.
4. Stop and set up for inspection.
5. When dismissed, back approximately one horse length.
6. Perform a 90 degree turn and walk away from judge.

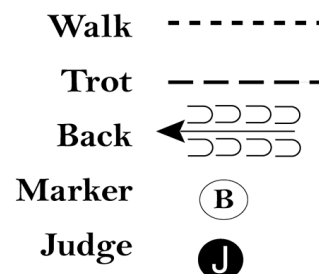

Follow the directions of your ring steward.

[S/2-58]

Pattern Provided by:

The Horses

ShoMe Spring ShoCase

Horsemanship Classes 68-69, 76-77

Show Date: 05-06-2022

w w w . H o r s e S h o w P a t t e r n s . c o m

w w w . H o r s e S h o w P a t t e r n s . c o m

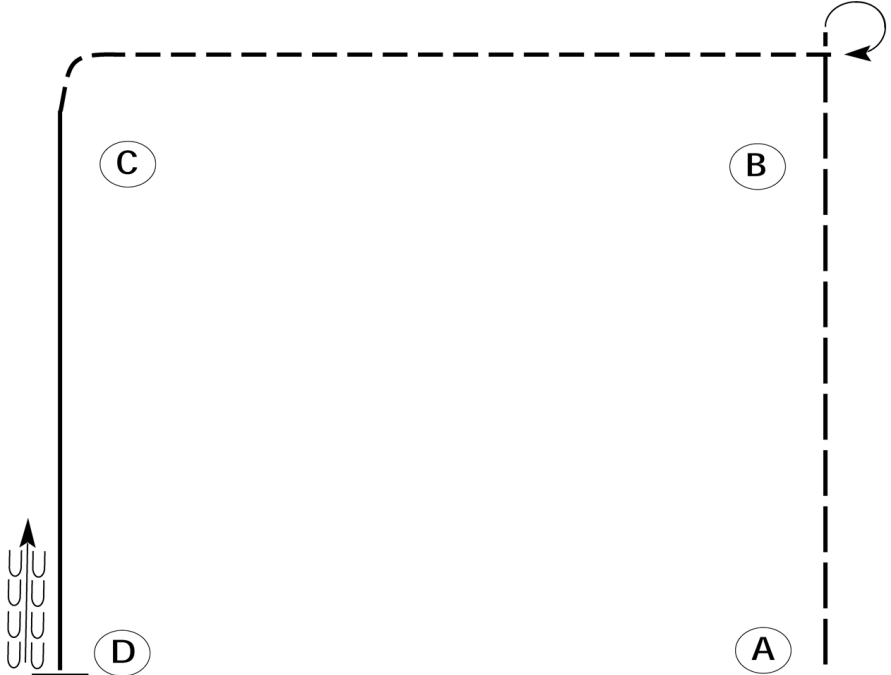

Be ready at A.

1. Extended jog from A to B.
2. Stop past B and execute a 270 degree turn to the right.
3. Jog from B around C.
4. Lope on the left lead from C to D.
5. Stop at D and back one horse length.

Please exit at a jog.

Walk	-----
Jog	- - - - -
Extended Jog	— — — —
Lope	—————
Leg Yield	
Lead Change	— / —
Back	← ← ← ← ←
Marker	⊙ B
Sidepass	← — — — — →

[WH/1-23]

Pattern Provided by:
The Horses

ShoMe Spring ShoCase

Horsemanship Classes 70-74

Show Date: 05-06-2022

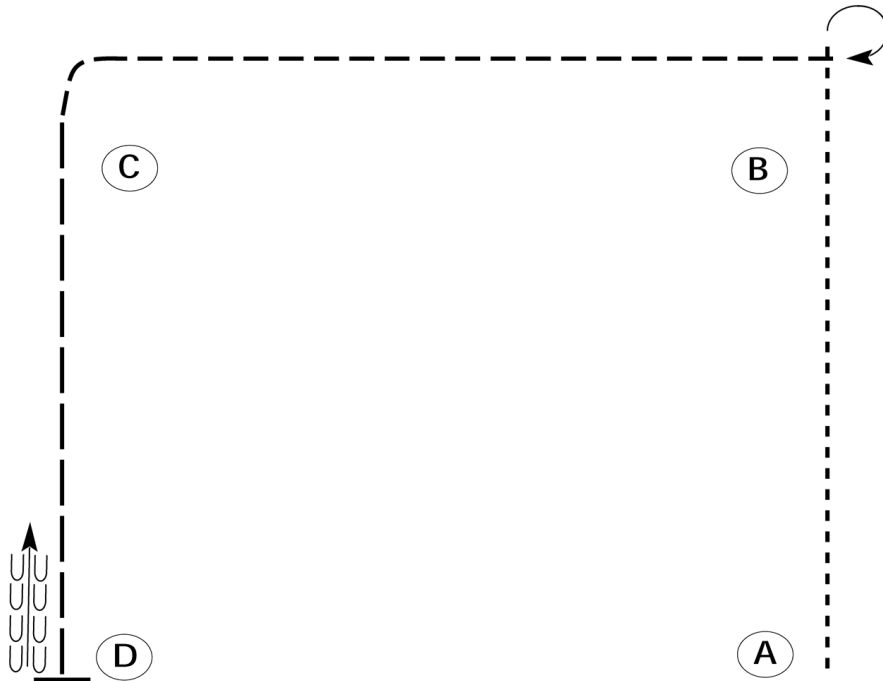

Be ready at A.

1. Walk from A to B.
2. Stop past B and execute a 270 degree turn to the right.
3. Jog from B around C.
4. Extend the jog from C to D.
5. Stop at D and back one horse length.

Please exit at a jog.

Walk -----

Jog - - - - -

Extended Jog - - - - -

Lope _____

Leg Yield |||||

Lead Change /

Back ← ← ← ← ←

Marker (B)

Sidepass ← ← ← ← ←

[WH/WT-23]

Pattern Provided by:

The Horses

w w w . H o r s e S h o w P a t t e r n s . c o m

w w w . H o r s e S h o w P a t t e r n s . c o m

ShoMe Spring ShoCase

Horsemanship Sweepstakes

Show Date: 05-06-2022

w w w . H o r s e S h o w P a t t e r n s . c o m

w w w . H o r s e S h o w P a t t e r n s . c o m

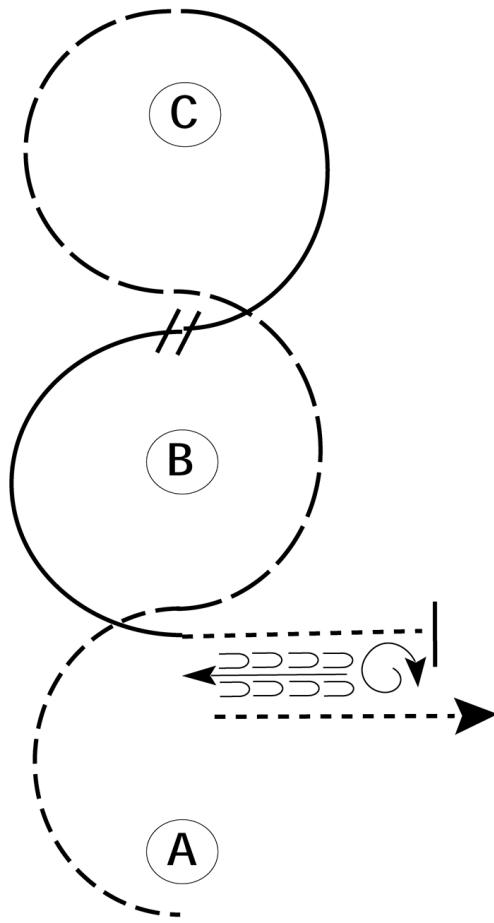

Be ready at A.

1. Jog in a half circle until between A and B.
2. Extend the jog around B and C as shown.
3. Lope on the right lead in a half circle until between C and B.
4. Perform a simple lead change.
5. Lope on the left lead in a half circle until between B and A.
6. Walk approximately 2 horse lengths.
7. Stop and perform a full turn to the right.
8. Back approximately one horse length and walk straight away.

Walk	-----
Jog	- - - - -
Extended Jog	- - - - -
Lope	
Lead Change	///
Back	←←←←←
Marker	ⓑ

Follow the instructions of your ring steward.

[WH/3-85]

Pattern Provided by:

The Horses

ShoMe Spring ShoCase

Horsemanship Classes 78-80

Show Date: 05-06-2022

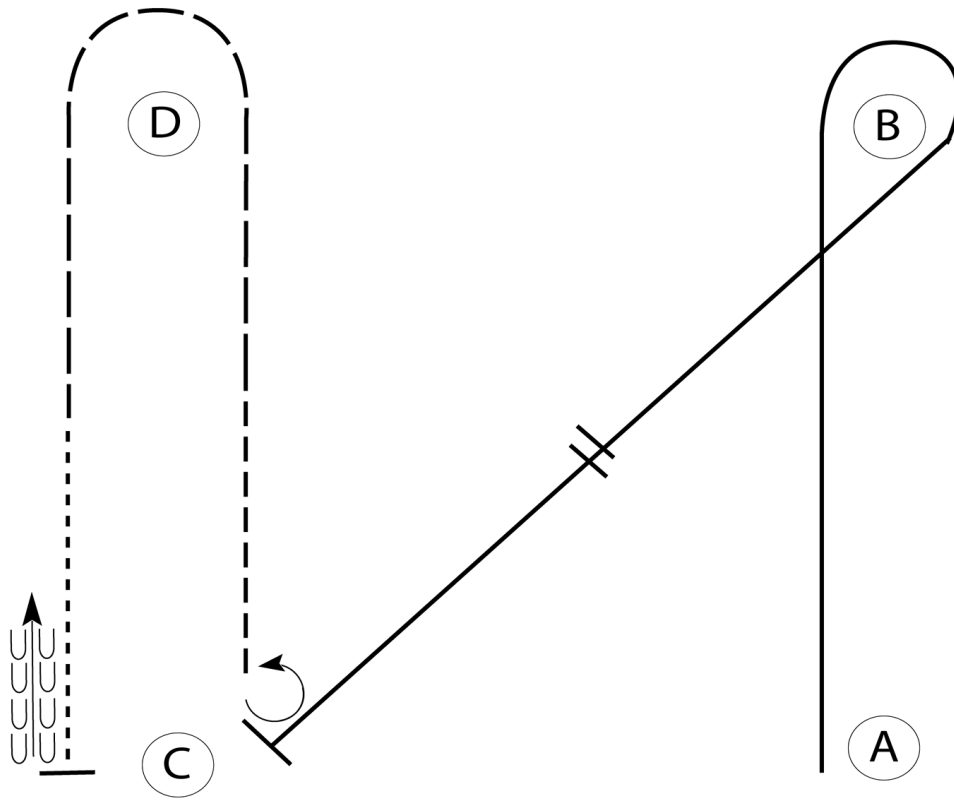

Be ready at A.

1. Lope on the right lead from A to and around B.
2. Halfway to C, perform a simple lead change.
3. Lope to C.
4. Stop and perform a 270 degree turn to the left.
5. Jog halfway to D.
6. Extend the jog to and around D.
7. Halfway to C, break to a walk.
8. Stop at C and back approximately one horse length.

Follow the instructions of your ring steward.

Walk	-----
Jog	- - - - -
Extended Jog	- - - - -
Lope	—————
Leg Yield	
Lead Change	— / —
Back	← ⊂ ⊂ ⊂ ⊂ ⊂
Marker	⊙ B
Sidepass	← ——— →

[WH/2-71]

Pattern Provided by:

The Horses

w w w . H o r s e S h o w P a t t e r n s . c o m

w w w . H o r s e S h o w P a t t e r n s . c o m

ShoMe Spring ShoCase

Bareback Horsemanship Challenge

Show Date: 05-06-2022

w w w . H o r s e S h o w P a t t e r n s . c o m

w w w . H o r s e S h o w P a t t e r n s . c o m

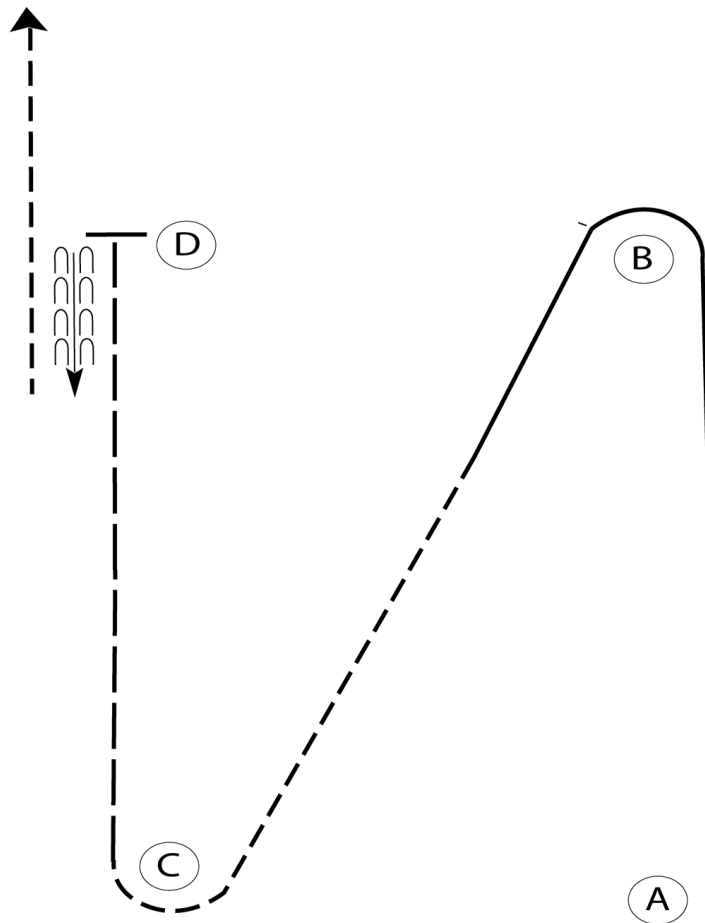

Be ready at A.

1. Walk two horse lengths from A.
2. Lope on the left lead to and around B.
3. Halfway between B and C, break to a jog.
4. Jog to and around C.
5. Extend the jog from C to D.
6. Stop at D and back approximately one horse length
7. Exit at a jog.

Follow the instructions of your ring steward.

Walk	-----
Jog	- - - - -
Extended Jog	- - - - -
Lope	—————
Leg Yield	
Lead Change	— / —
Back	← c c c c
Marker	Ⓚ
Sidepass	← — — — →

[WH/1-66]

Pattern Provided by:
The Horses

Walk Only Obstacle Class 84

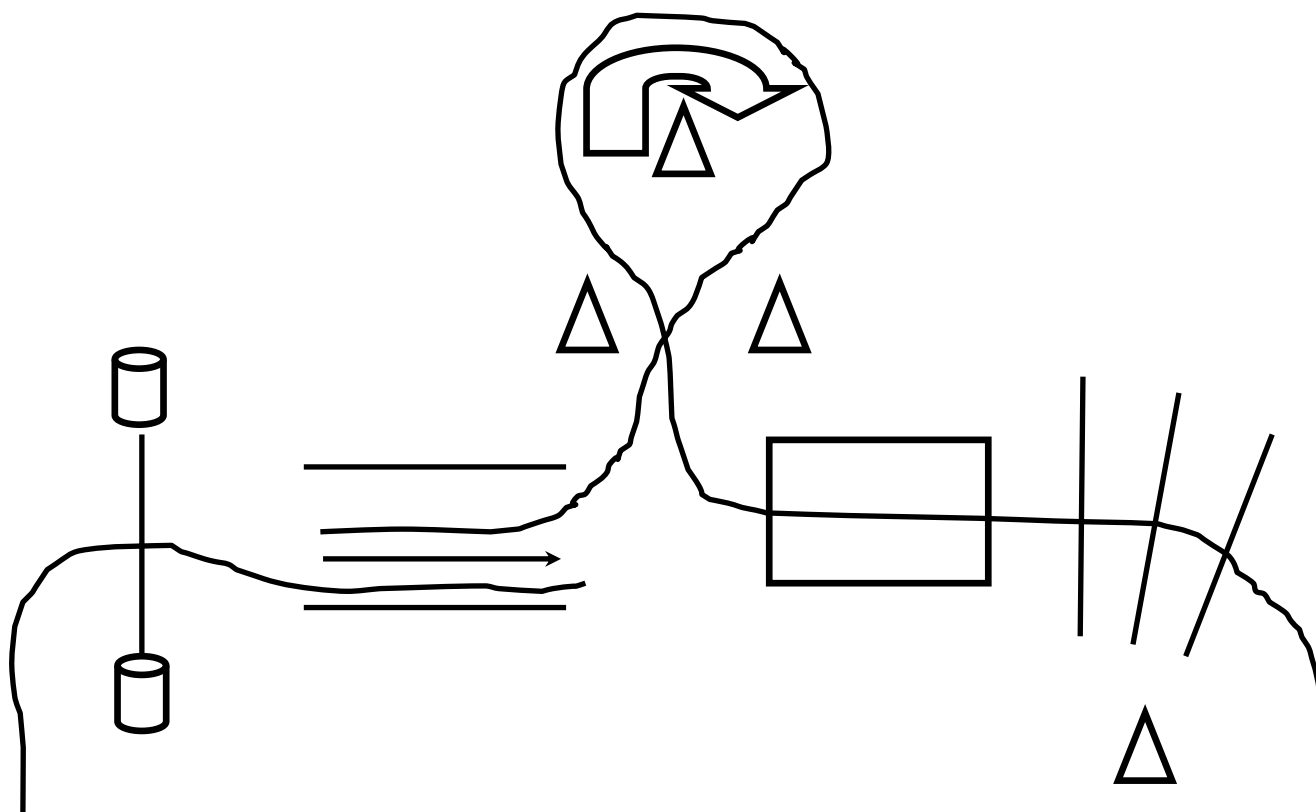

1. Start at A and walk poles
2. Walk over bridge
3. Walk cone triangle and through chute
4. Back 5-6 steps through chute
5. Walk over pole between barrels and exit

Ranch Reining Class 89

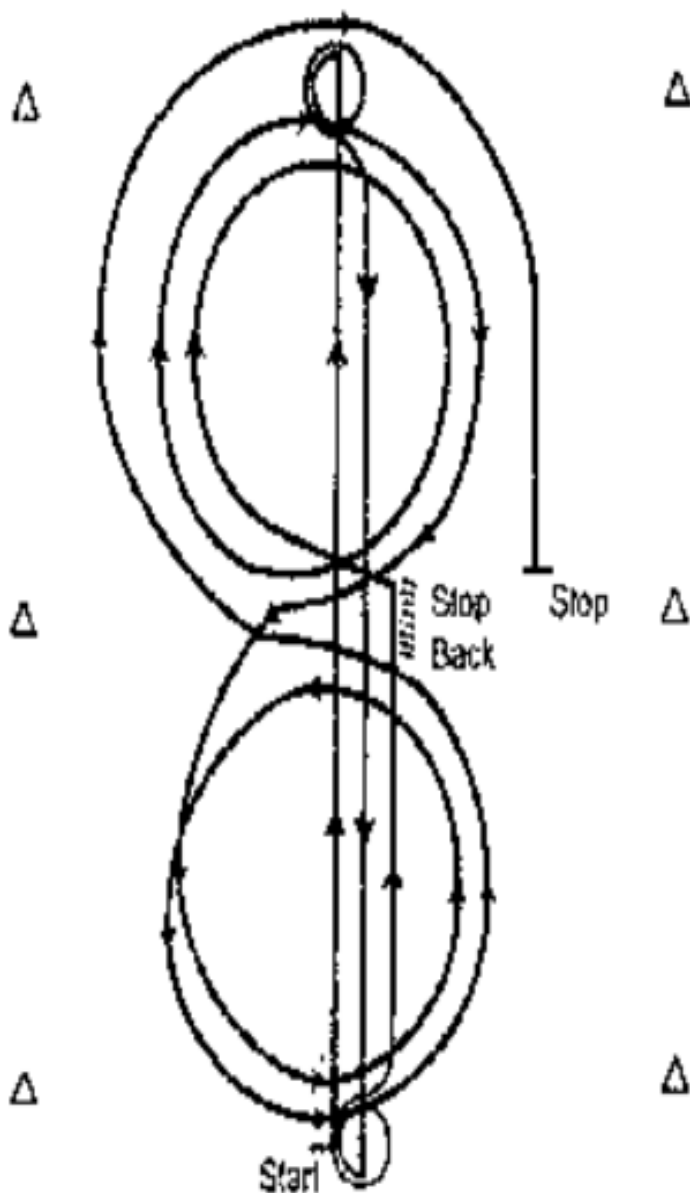

BEGIN AT END OF THE ARENA

1. Run to far end of arena past the end marker and stop.
 2. Execute 1 1/2 (one and one-half) spins to the left.
 3. Run to other end of arena past the end marker and stop.
 4. Execute 1 1/2 (one and one-half) spins to the right.
 5. Run past the center marker and stop.
 6. Back 10 to 15 feet in a straight line.
 7. Complete 1/4 (one-quarter) of a turn to the left, hesitate. On right lead complete one small, slow circle and one large, fast circle. Change leads to left.
 8. Complete one small, slow circle and one large, fast circle. Change leads to the right.
 9. Run around the end of arena to the other side, past center marker, at least 20 feet from the fence and stop, hesitate to complete pattern.
 10. Approach judge for inspection and dismissal.
- Rider may drop bridle to the designated judge.

ShoMe Spring ShoCase

Saddle Seat Equitation

Show Date: 05-06-2022

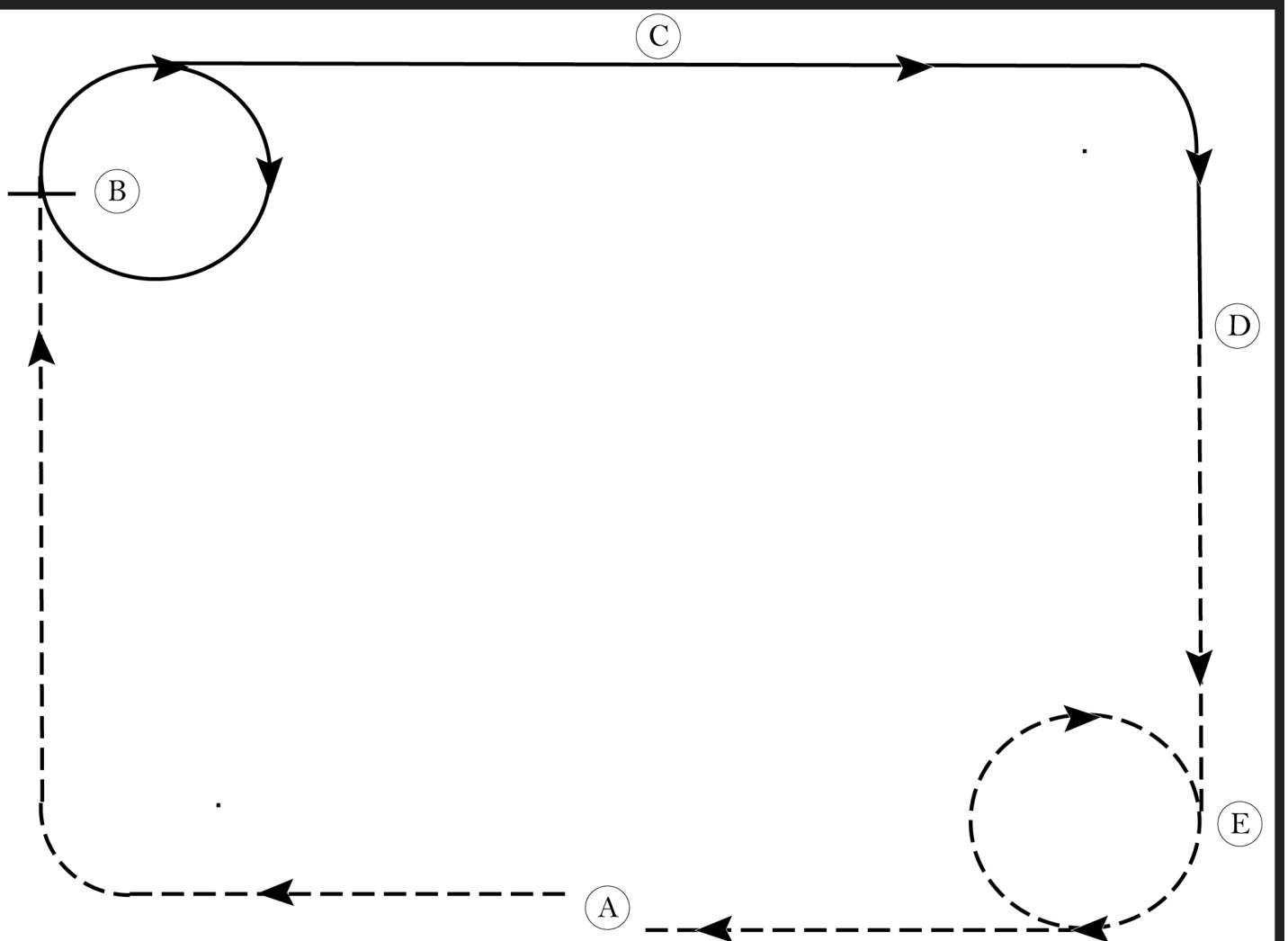

Begin at the mid-point of the in gate end of arena (A).

1. Trot to the left, around the curve and to the end of the straightaway (B). Stop briefly.
2. Canter a circle to the right on the right lead and continue past C and to a point 1/3 the way down the straightaway (D).
3. Trot down the straightaway and at the curve circle in a clockwise direction.
4. Continue the trot around the curve and back to the mid point of the straightaway (A).

The workout has been completed - Thank You.

Walk
Trot	-----
Extended Trot	-----
Canter	—————
Lead Change	
Back	
Reference Point	(B)

[SSE/2]

Pattern Provided by:

The Horses

ShoMe Spring ShoCase

Equitation Classes 102-106

Show Date: 05-06-2022

w w w . H o r s e S h o w P a t t e r n s . c o m

w w w . H o r s e S h o w P a t t e r n s . c o m

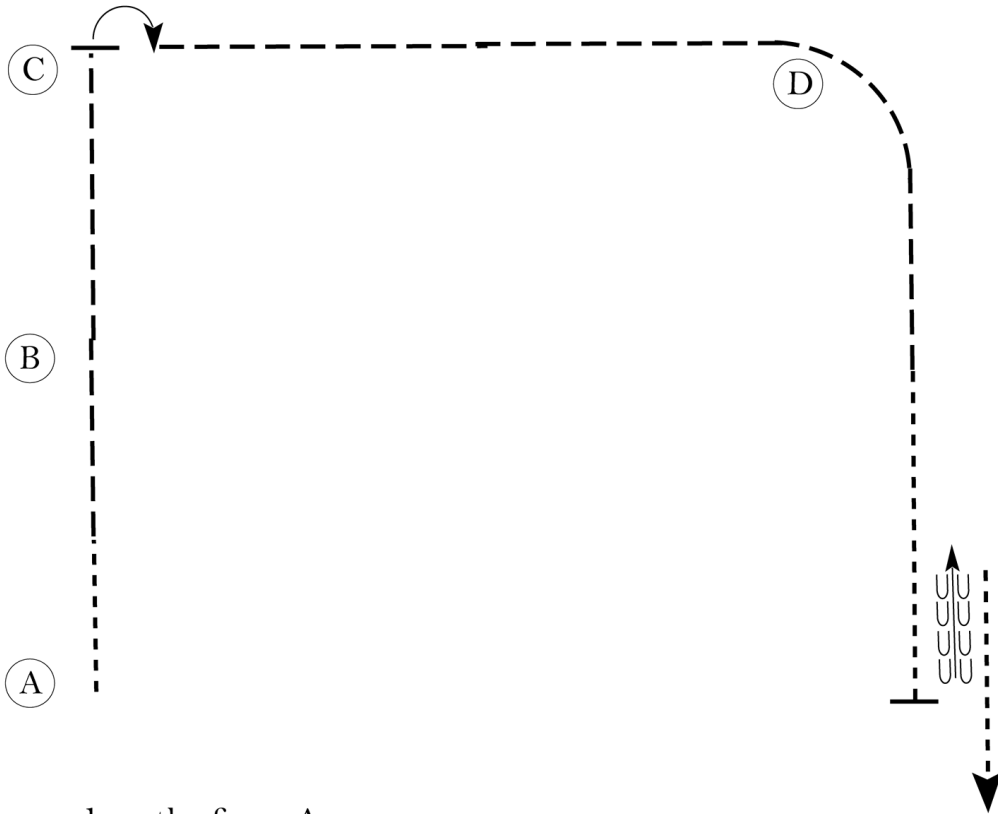

Be ready at A.

1. Walk two horse lengths from A.
2. Posting trot on the right diagonal to C.
3. Stop at C and perform a 90 degree turn on the hindquarters to the right.
4. Trot on the left diagonal to and around D.
5. When even with B, begin to walk.
6. Stop when even with A and back approximately one horse length.

Walk away from D and follow the instructions of your ring steward.

Walk	-----
Trot	- - - - -
Extended Trot	— — — — —
Canter	—————
Leg Yield	
Lead Change	— / —
Back	← ← ← ← ←
Marker	⊙
Sidepass	← — — — — →
Hand Gallop	— — — — —

[HSE/WT-44]

Pattern Provided by:

The Horses

ShoMe Spring ShoCase

Equitation Sweepstakes

Show Date: 05-06-2022

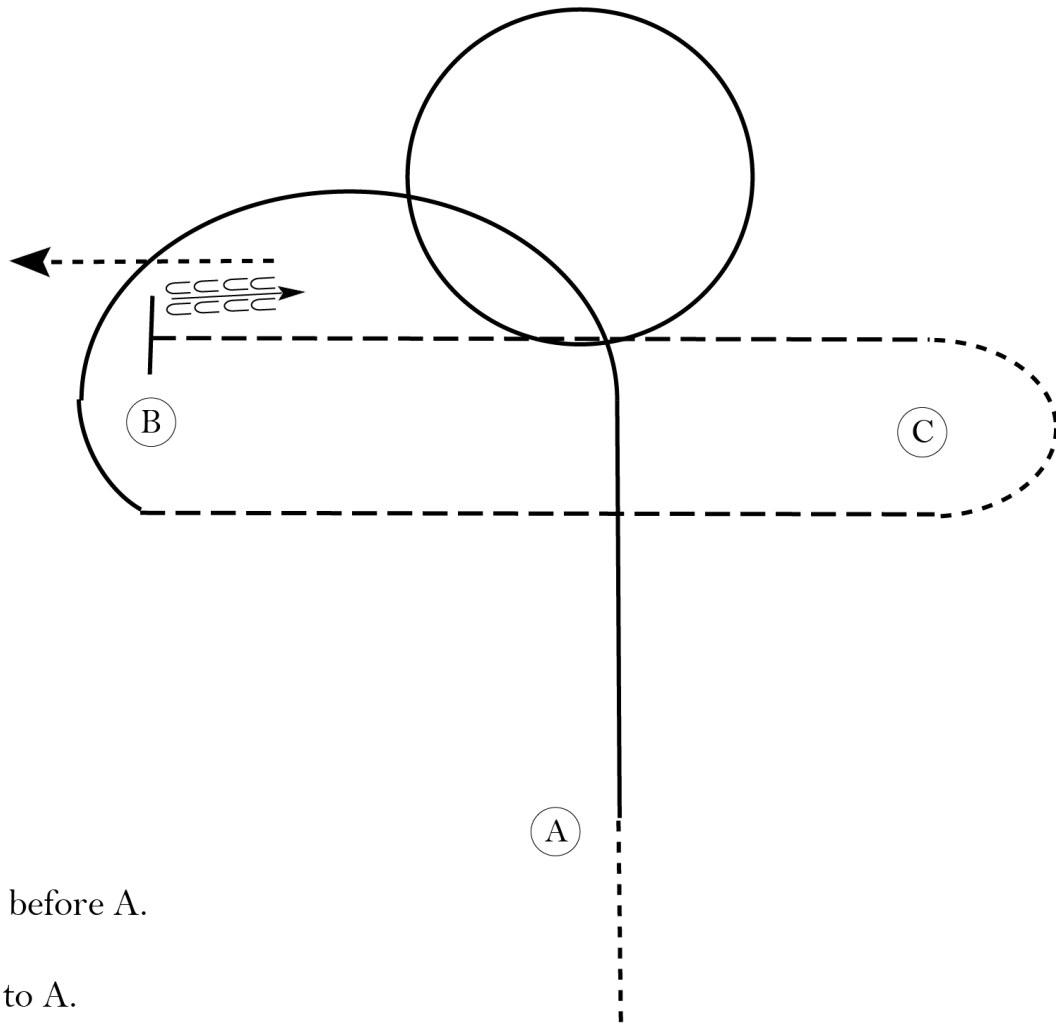

Be ready before A.

1. Walk to A.
2. Canter on the left lead to center of pattern and in a half circle around B.
3. Trot on the right diagonal from B to C.
4. Walk around C.
5. Trot on the left diagonal halfway to B.
6. Canter a right lead circle.
7. Sitting trot until even with B.
8. Halt at B and back approximately one horse length. Walk straight away.

Follow the instructions of your ring steward.

Walk	-----
Trot	- - - - -
Extended Trot	— — — — —
Canter	—————
Leg Yield	
Lead Change	↘ ↙
Back	← ← ← ← ←
Marker	(B)
Sidepass	← ← ← ← ←
Hand Gallop	— — — — —

[HSE/3-60]

Pattern Provided by:

The Horses

ShoMe Spring ShoCase

Bareback Equitation Challenge

Show Date: 05-06-2022

w w w . H o r s e S h o w P a t t e r n s . c o m

w w w . H o r s e S h o w P a t t e r n s . c o m

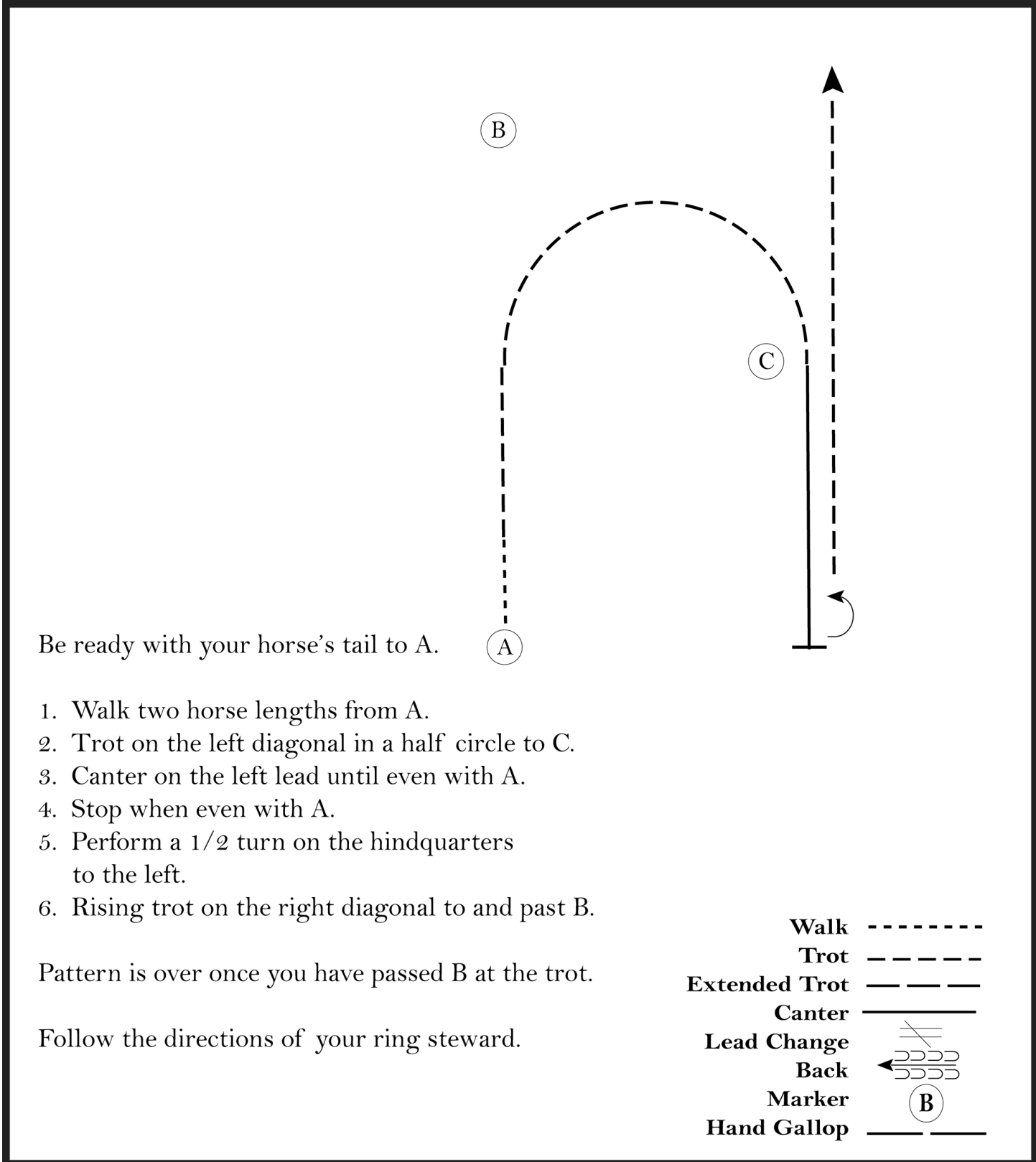

Be ready with your horse's tail to A.

1. Walk two horse lengths from A.
2. Trot on the left diagonal in a half circle to C.
3. Canter on the left lead until even with A.
4. Stop when even with A.
5. Perform a 1/2 turn on the hindquarters to the left.
6. Rising trot on the right diagonal to and past B.

Pattern is over once you have passed B at the trot.

Follow the directions of your ring steward.

Walk	-----
Trot
Extended Trot	-----
Canter	—————
Lead Change	
Back	
Marker	Ⓚ
Hand Gallop	—————

[HSE/1-51]

Pattern Provided by:

The Horses

ShoMe Spring ShoCase

Equitation Classes 109-110, 115

Show Date: 05-06-2022

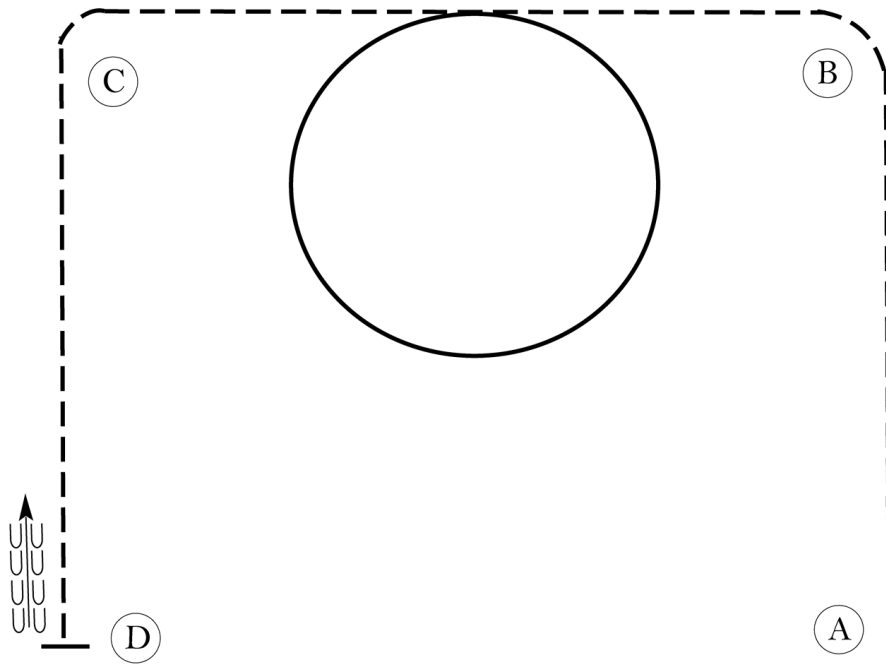

Be ready at A.

1. Walk two horse lengths from A.
2. Posting trot on the right diagonal to and around B and halfway to C.
3. Halfway to C, canter a circle to the left.
4. Close the circle and trot on the right diagonal to C.
5. Change diagonals and trot on the left diagonal to D.
6. Halt at D and back approximately one horse length.

Follow the instructions of your ring steward.

Walk	-----
Trot	- - - - -
Extended Trot	— — — — —
Canter	—————
Leg Yield	
Lead Change	↙ ↘
Back	← ← ← ← ←
Marker	(B)
Sidepass	← — — — — →
Hand Gallop	— — — — —

[HSE/1-62]

Pattern Provided by:

The Horses

ShoMe Spring ShoCase

Equitation Classes 111-113

Show Date: 05-06-2022

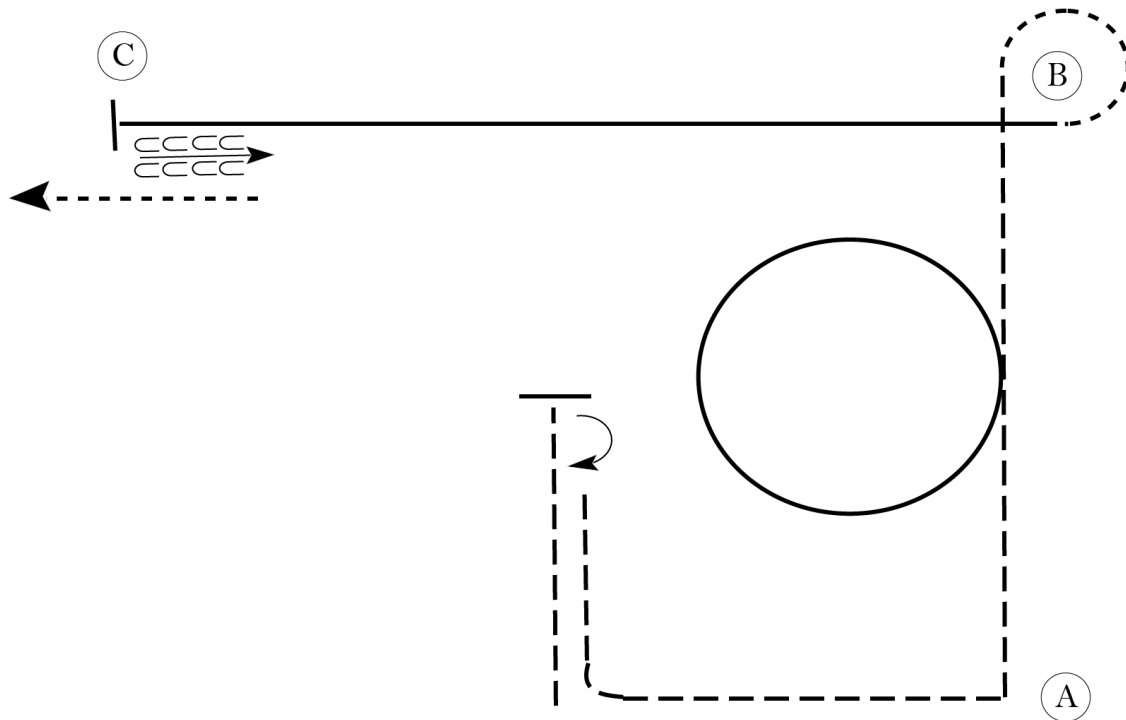

Be ready halfway between B and C and even with A.

1. Sitting trot to center of pattern.
2. Halt and perform a 180 degree turn on the forehand to the right.
3. Posting trot on the right diagonal toward A and halfway to B.
4. Canter a circle to the left halfway between A and B.
5. Posting trot on the left diagonal to B.
6. Walk around B.
7. Canter on the right lead to C.
8. Halt and back approximately one horse length.

Pattern is over once you have backed. Walk off and follow the instructions of your ring steward.

Walk	-----
Trot	- - - - -
Extended Trot	-----
Canter	=====
Leg Yield	
Lead Change	↙
Back	←←←←← ←←←←←
Marker	(B)
Sidepass	←-----←
Hand Gallop	-----

[HSE/3-74]

Pattern Provided by:

The Horses

w w w . H o r s e S h o w P a t t e r n s . c o m

w w w . H o r s e S h o w P a t t e r n s . c o m