



Kawneer UK Ltd
Astmoor Road, Astmoor Industrial Estate
Runcorn, Cheshire WA7 1QQ, United Kingdom
Tel: +44 (0) 1928 502500 Fax: +44 (0) 1928 502501

London Office
41-42 Eastcastle Street
London W1W 8DU
Tel: +44 (0) 207 409 1422 Fax: +44 (0) 207 409 1466
Email: kuk.kawneer@alcoa.com
www.kawneer.co.uk

Other brochures available on request from Kawneer are:

- Architectural Aluminium Systems Finishes
- Entrance Doors and Framing Systems
- Curtain Wall Systems
- Window Systems
- AA®601TE Parallel Opening Window
The Optimum Ventilation Solution for Maximum Air Exchange
- AA®3610LS Linked Sash Vertical Sliding Window
The Optimum Ventilation Solution for your Education and Health Projects
- Specialist Horizontal Sliding Window Solutions for your Healthcare Project
- Architectural Aluminium Glazing Systems Specification Guide

Specialist Kawneer Contractor:



Kawneer's continuous development and engineering programmes may bring about product changes. Kawneer reserves the right to introduce without notice such changes which will not detract from the product's performance
© KAWNEER UK LTD

AA®130 Brise Soleil System Solar Shading for Reduced Solar Heat Gain

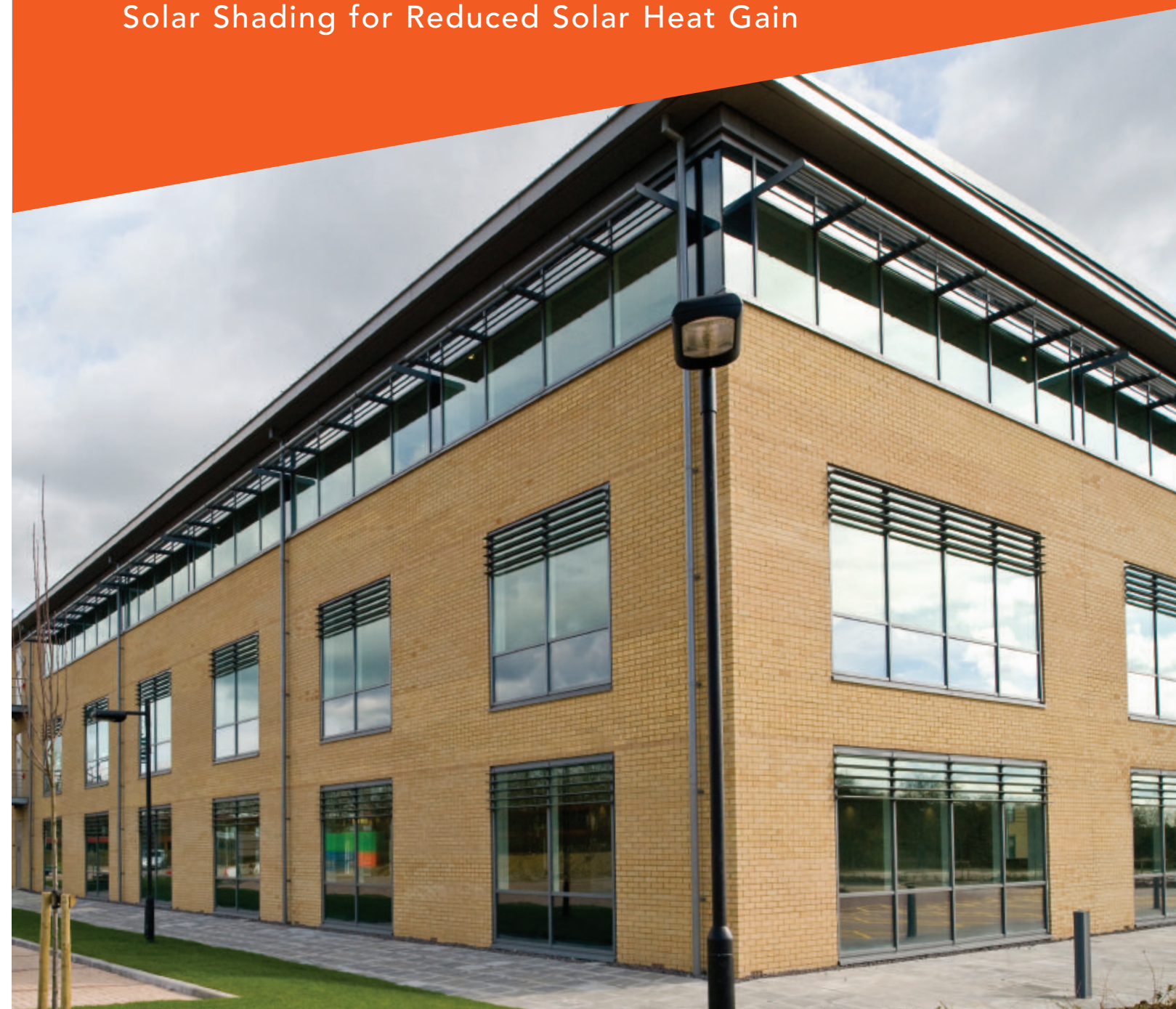

A R C H I T E C T U R A L A L U M I N I U M G L A Z I N G S Y S T E M S



Solar Shading for reduced solar heat gain

Introduction

Kawneer is one of the UK's leading architectural aluminium glazing systems manufacturers. We have a long track record of successful project delivery in various markets including, Commercial, Residential, Health and Education, providing best value and best practice solutions.

AA®130 Brise Soleil System

Kawneer's Curtain Wall, Window and Framing Systems can accommodate our AA®130 Brise Soleil System which adds a stunning design statement to the building façade; optimising the natural daylight within a building whilst limiting the solar heat gain and glare to provide optimum comfort for residents.

The AA®130 Brise Soleil System consists of aluminium blades which are available as standard and bespoke variants to suit any project application where solar heat and glare is an important consideration.

Performance

Use of solar shading on building façades to limit the building's solar heat gain can contribute to the thermal performance of the building by:

- Reducing the energy consumption (due to air conditioning)
- Allowing greater use of natural ventilation
- Limiting direct solar radiation whilst maintaining natural light levels

Aesthetics

The AA®130 System offers a range of extruded aluminium sections in a variety of shapes, sizes and colours to suit specific building requirements and increase the aesthetics of the façade.



Photograph and Front Cover Photograph: BAM Construct UK

Hempton Court, Bristol
Aukett Fitzroy Robinson

Brise Soleil, Curtain Wall, Entrance Doors

Sustainability

Aluminium is one of the best materials available for construction. Aside from its practical and energy-saving advantages, it can be recycled repeatedly without loss of properties using just 5% of the energy originally used to mine, smelt and produce it. Aluminium's natural strength, lightness and durability makes it the ideal material for meeting architects glazing requirements.

For our own production, we use recycled aluminium billets 100% of the time.

For more detailed information on our sustainability credentials, a Sustainability Brochure can be downloaded from our website: www.kawneer.co.uk

Product Features

- Suites with the AA®100/AA®110 and AA®201 Curtain Wall, 451PT and AA®4001 Framing and AA®600TE and AA®600TEPlus Window Series
- A choice of Aerofoil Blades with a size range from 100mm to 400mm and Quarter Round Blades with a size range from 100mm to 250mm
- Horizontal Single Blade Options with 3 angles available - 0°, 22.5° and 45°. Horizontal Outrigger and Multiple Blade Options with 3 reaches available - 1000mm, 1500mm and 2000mm
- Glazing Systems and Brise Soleil from one manufacturer
- Control of solar glare, whilst maximising the amount of natural light reaching the building's internal environment
- Reduction in solar heat gain and allows greater use of natural ventilation
- Flexibility and choice according to individual requirements, providing a stunning aesthetic statement that unites the building façade
- Total design flexibility Offering total project solutions

With the decisive advantage of...

Solar Gain Calculations

For further advice and support in working out Solar Gain Calculations please contact our Technical Services Department or our Architectural Advisors by calling our Head Office at Runcorn on 01928 502500.

Construction

The AA®130 System consists of aluminium blades, brackets and outriggers, supporting arms and connections to the façade.

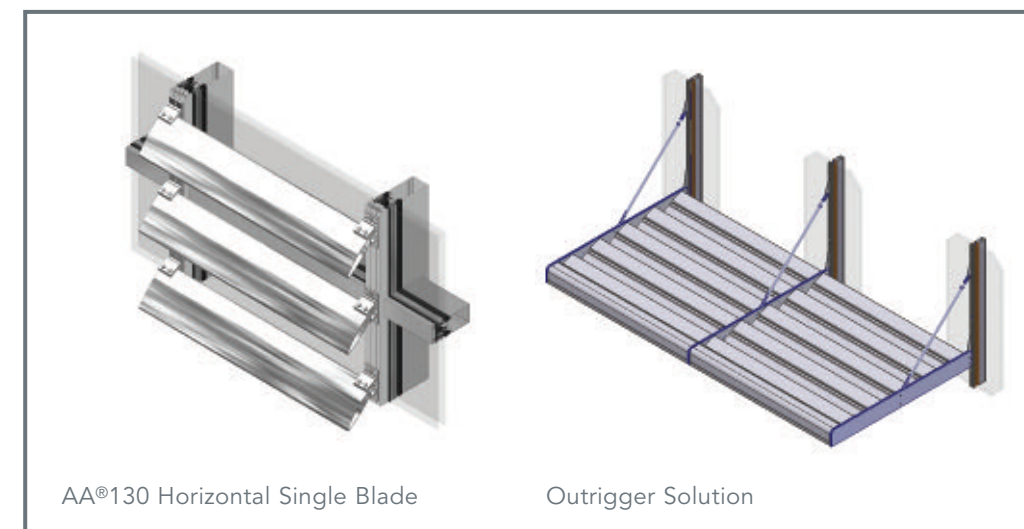

AA®130 Horizontal Single Blade

Outrigger Solution

Wide Range of Aluminium Profiles to suit any Project Application

Integrated Brise Soleil

The Kawneer AA®130 Brise Soleil System is fully compatible with the AA®100/AA®110 and AA®201 Curtain Walling Systems, the 451PT and AA®4001 Framing Systems and AA®600TE and AA®600TEPlus Window Systems.

Integration with the systems is achieved using specially designed connection brackets, designed to offer ease of installation for even the most demanding projects.

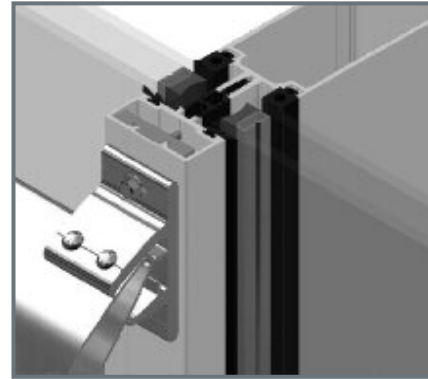

Typical Connection Brackets and Single Blade Combinations

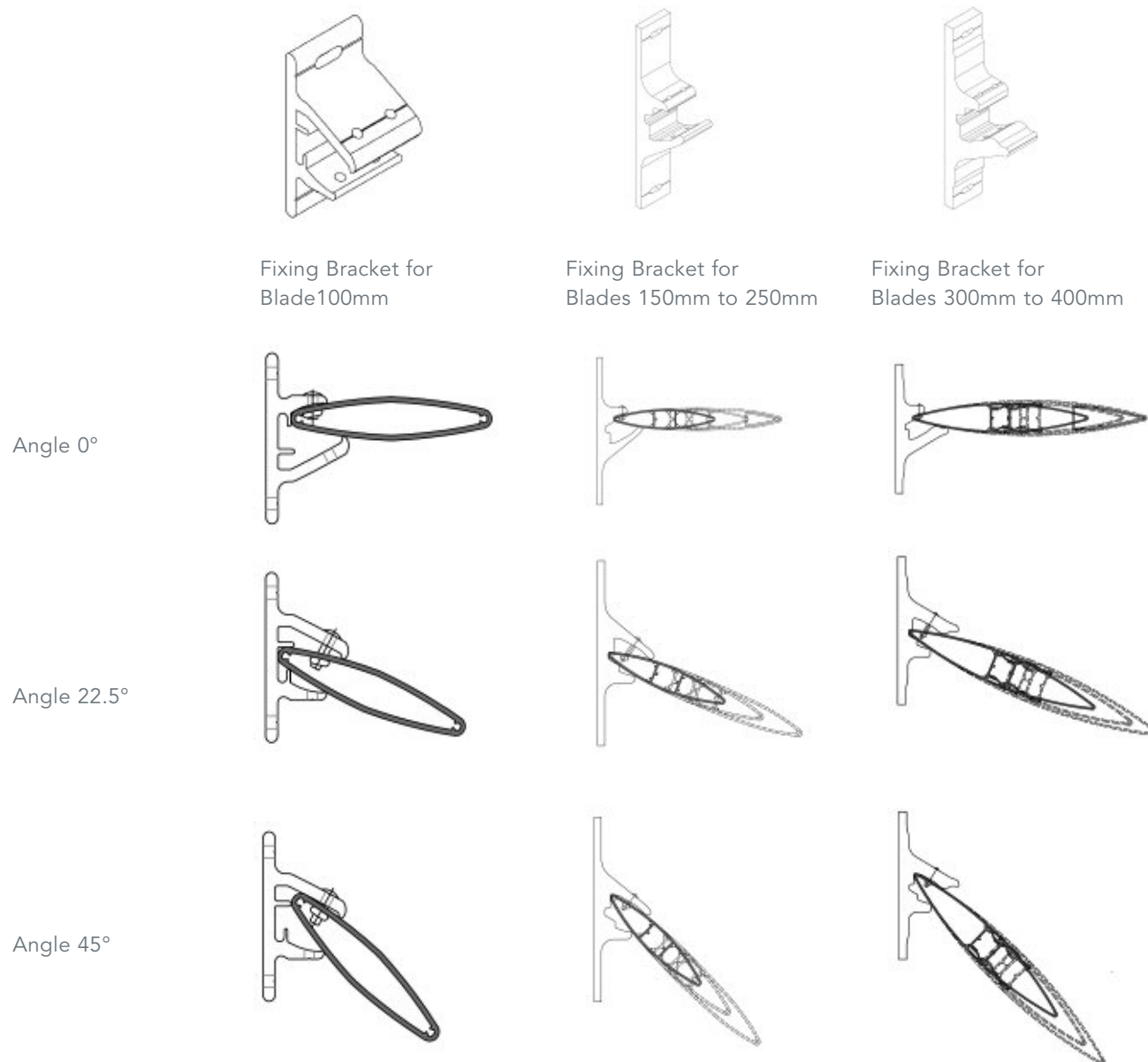

Typical Outrigger Blade Combinations

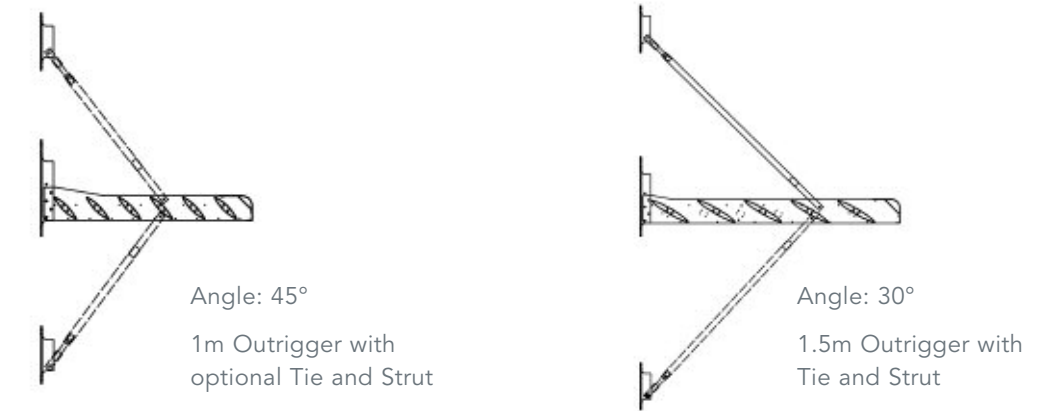

Note: Brackets supplied by Kawneer

AA®130 Brise Soleil Blade Range

100 x 21.5 Aerofoil Blade Maximum Span 3560	100 x 18.5 Quarter Round Blade Maximum Span 3700 *
150 x 30 Aerofoil Blade Maximum Span 4230	150 x 18.5 Quarter Round Blade Maximum Span 4460 *
200 x 32.5 Aerofoil Blade Maximum Span 4880	200 x 18.5 Quarter Round Blade Maximum Span 5100 *
250 x 33.5 Aerofoil Blade Maximum Span 5470	250 x 24 Quarter Round Blade Maximum Span 5690 *
300 x 50 Aerofoil Blade Maximum Span 6400	
360 x 50 Aerofoil Blade Maximum Span 6400	
400 x 60 Aerofoil Blade Maximum Span 6400	

* For Outrigger Only

Note:
Maximum Spans are based on a Pressure Limitation of 800Pa at an angle of 45°
Please refer to Section B of the AA®130 Brise Soleil Product Manual for further Span Dimensions

Product Quality and Installation

Kawneer Manufacturing

Kawneer is an ISO 9001 company. We provide a unique single source responsibility for product design, extrusion and finishing. In addition we offer technical design support tailored to the needs of your project large or small.

Our designers ensure they develop advanced systems to assist in the reduction of the Whole Life Costs of buildings.



Certificate No. FM 01954



Certificate No. EMS 70103

Kawneer is also accredited to Environmental Standard – ISO 14001 (2004 Version).

Nationwide Network of Approved Specialist Contractors

Our fabricators and installers are fully trained prior to approval, and regularly undergo top-up courses to ensure that their skill levels have been maintained as well as receiving instruction on new products or product modifications. All training will be provided by CWCT approved Kawneer staff.

Burlington Danes Academy, London
BHM Architects

Brise Soleil, Curtain Wall, Casement Windows,
Entrance Doors

Supporting Your Projects



A full range of guaranteed colours available

Kawneer Permacover™ is a high quality polyester powder paint finish, offering over 130 standard and 31 metallic paint colours and providing outstanding resistance to environmental conditions. Kawneer Permacover™ has 30 year gloss and a 30 year matt and metallic guarantees subject to application and Kawneer acceptance in marine, industrial, swimming pools or other aggressive atmospheres.

Kawneer Permanodic® is a range of subtle co-ordinated colours which have been researched and developed for architectural systems. Kawneer Permanodic® is a tried and tested anodising process, proven in accelerated laboratory tests, extensive field trials and contract experience. Subject to compliance with Kawneer's requirements, a 25 year finishes guarantee can be obtained from our Head Office.

Authorities

- ISO 9001:2000
Quality Management System
- BS EN 12020
Extruded precision aluminium profiles
- BS 3987
Specification for anodic coatings
- BS 6496
Specification for powder organic coatings

Project Assistance

Kawneer's regionally based team of Architectural Advisors and the Architectural Services Team based at our Head Office in Runcorn are able to provide project advice and support:

Tel: 01928 502604 / Fax: 01928 502512
Email: kawneerAST@alcoa.com

Information on Kawneer's extensive range of Curtain Wall, Window, Framing and Door solutions can also be obtained from our Head Office by calling:

Tel: 01928 502612

Kawneer UK Ltd is part of Alcoa Building and Construction Systems, and enjoys the extensive resources of the entire Alcoa organisation, allied to the specific glazing systems experience of Kawneer's many operations around the world. As a result of this our partners and customers have direct access to one of the largest pools of technical expertise in the construction industry.

