

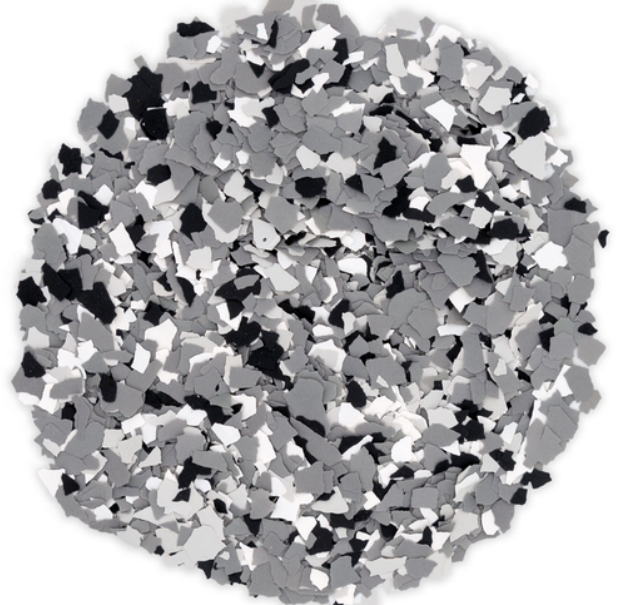

GRAPHITE



CHARCOAL



TWILIGHT

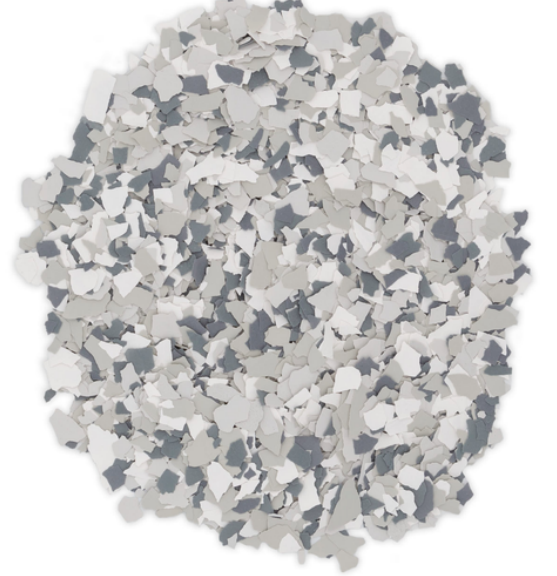

ARTIC

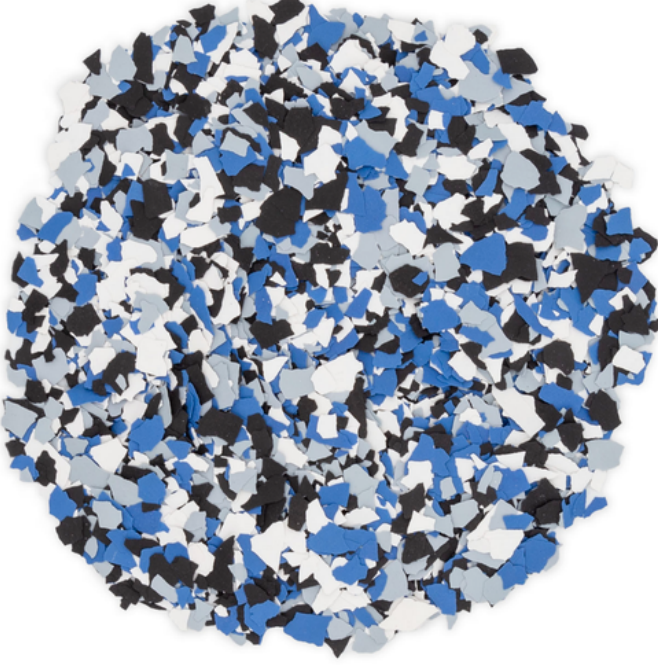

COBALT

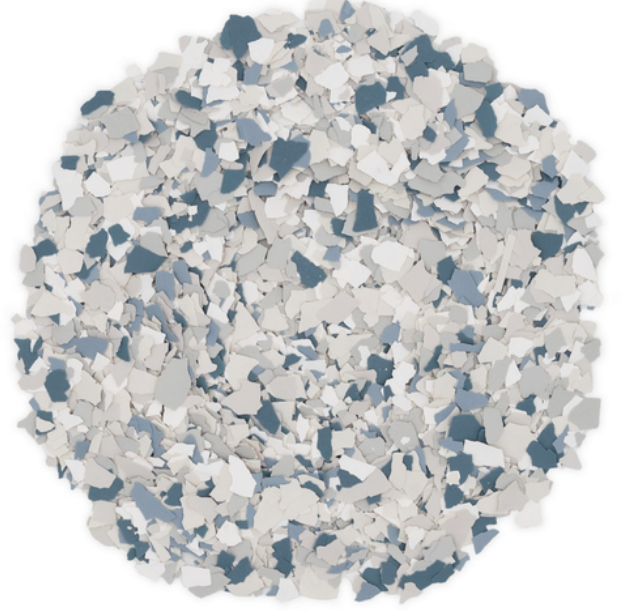

DENIM



GRANOLA

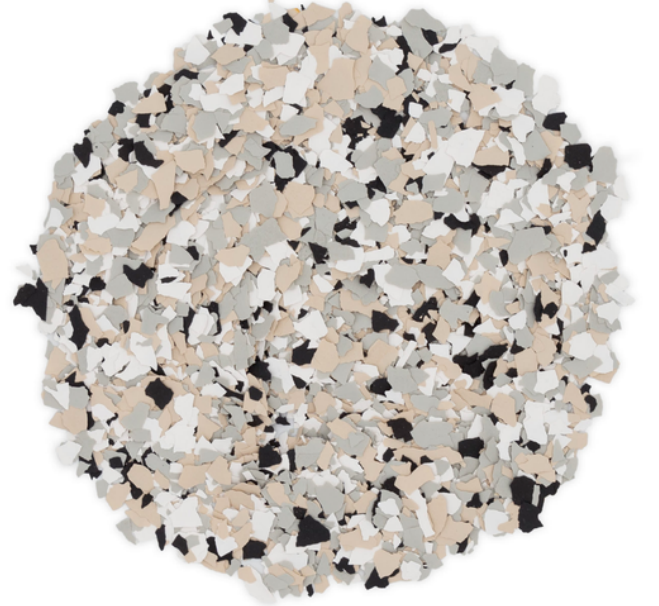

FOSSIL



TUSCANY



SAHARA

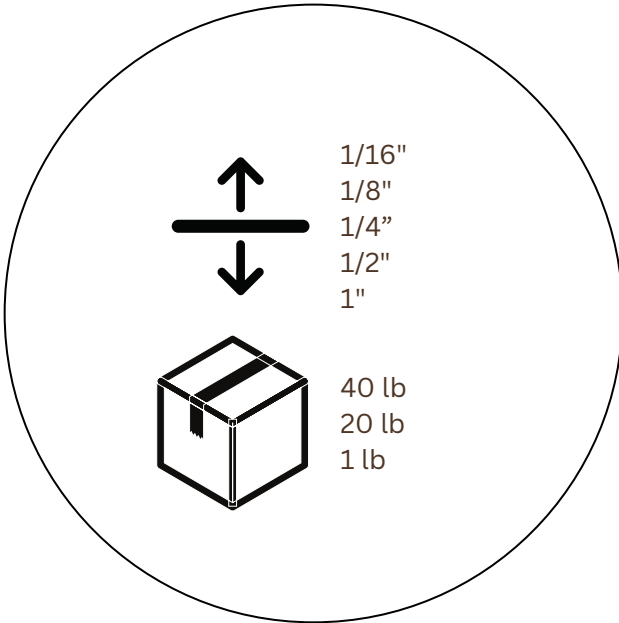



**likit
granit**

**SOLID
COLORS**

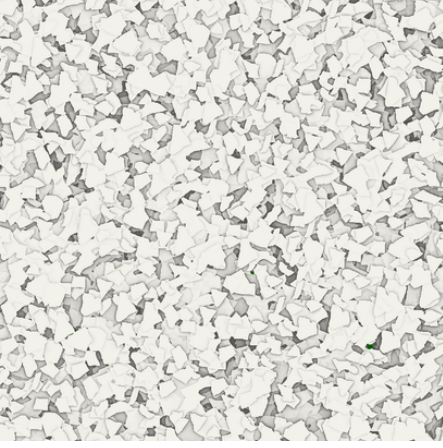

1820

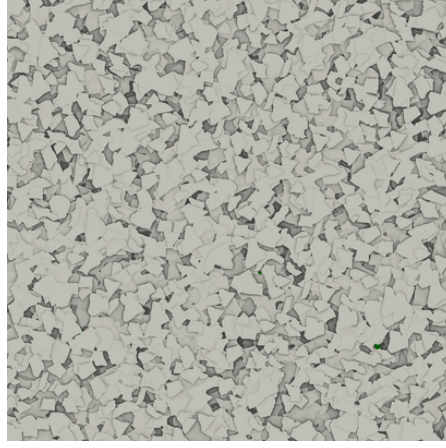

1410

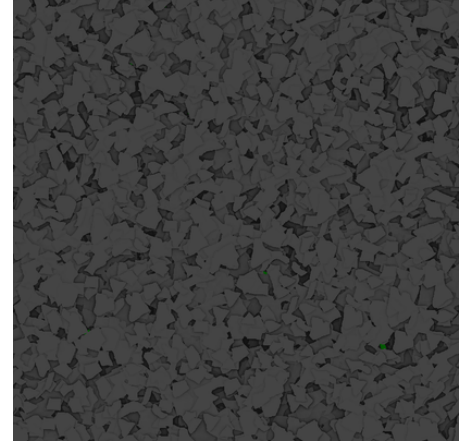

1050

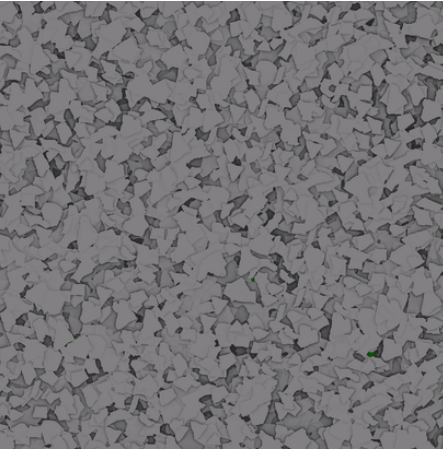

GREY

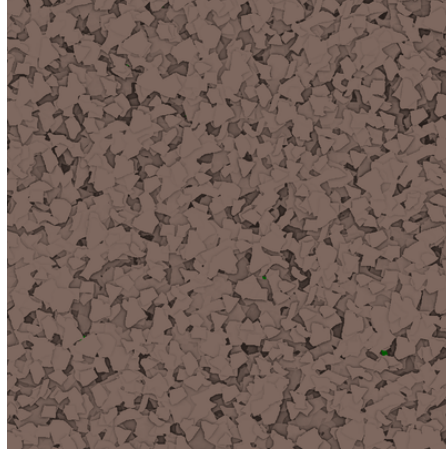

1060

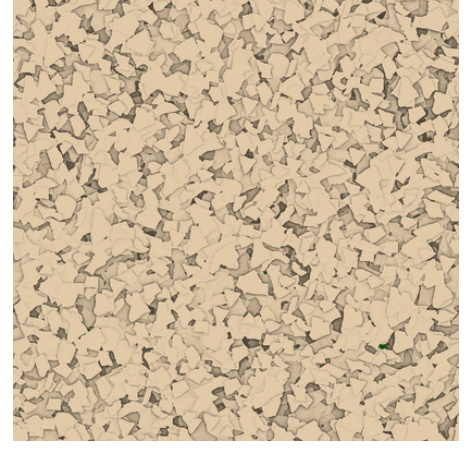

1785

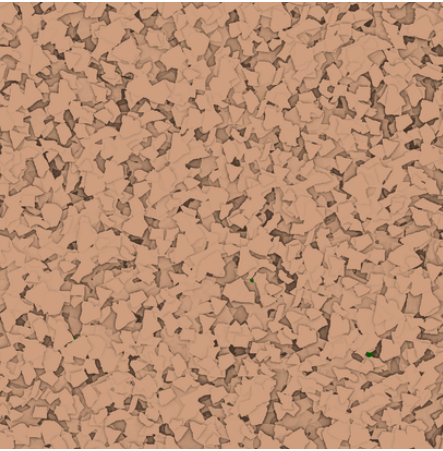

1770

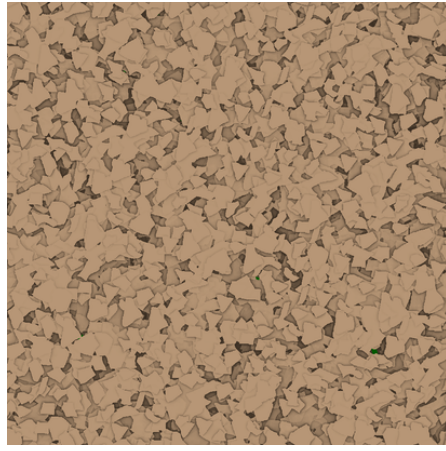

1040

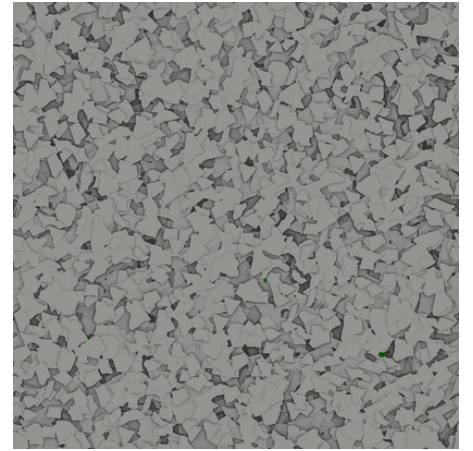

1090

ŞAP-MERSAN LTD STİ
KARESİ VD 8000256063
Pasa Alanı Mh 30 Sk No 11 Karesi Balıkesir TÜRKİYE
www.likitgranit.com
info@akrikor.com +90 541 427 6270





**likit
granit**

**SOLID
COLORS**

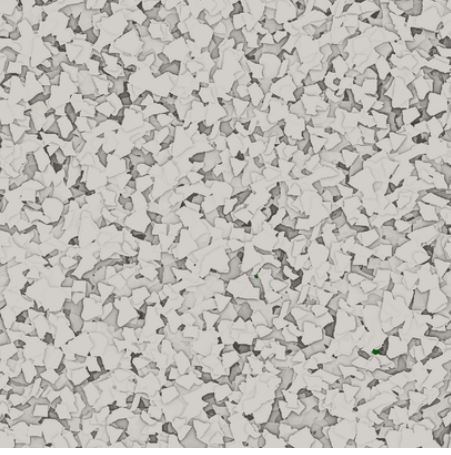

9958

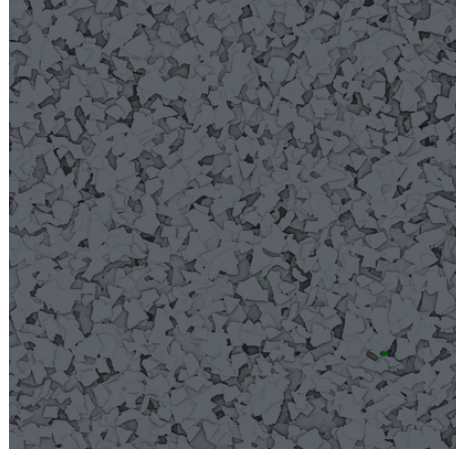

5920

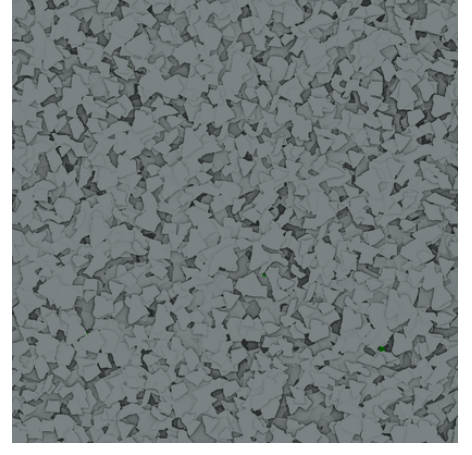

1415

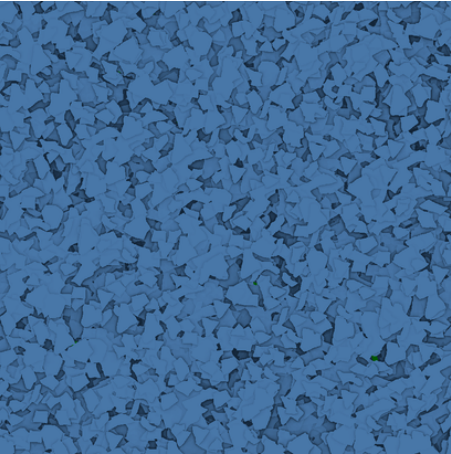

1790

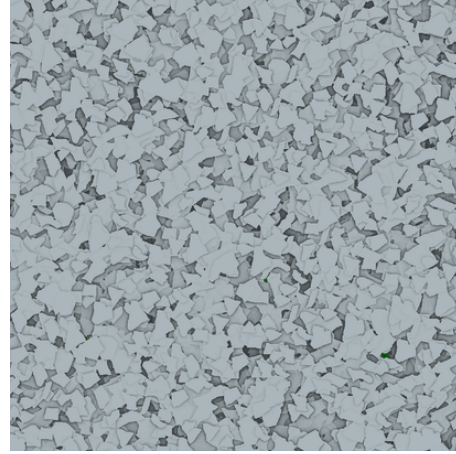

1480

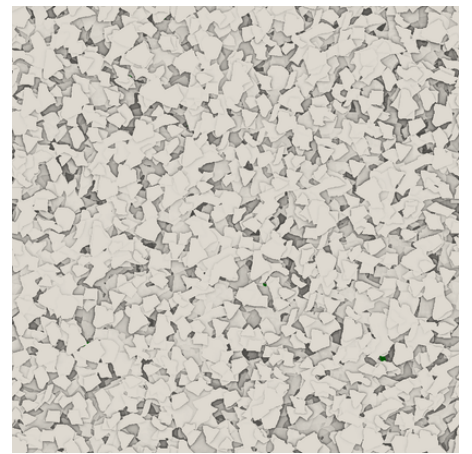

9959

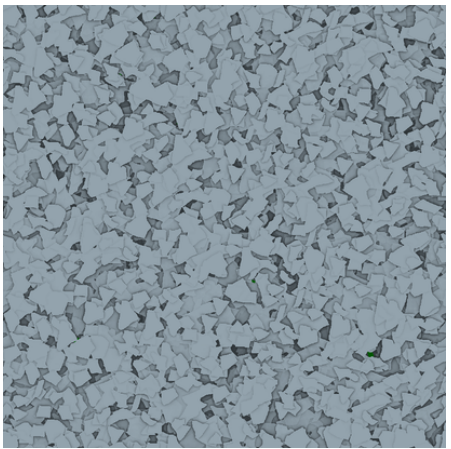

6621

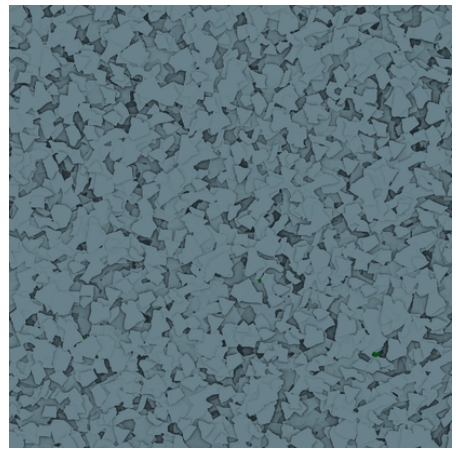

9972

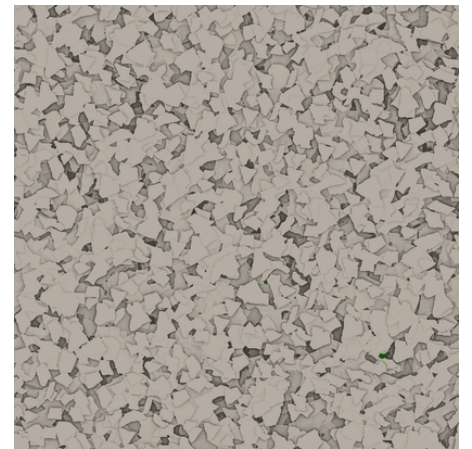

9987

ŞAP-MERSAN LTD STİ
KARESİ VD 8000256063
Pasa Alanı Mh 30 Sk No 11 Karesi Balıkesir TÜRKİYE
www.likitgranit.com
info@akrikor.com +90 541 427 6270





**likit
granit**

**SOLID
COLORS**

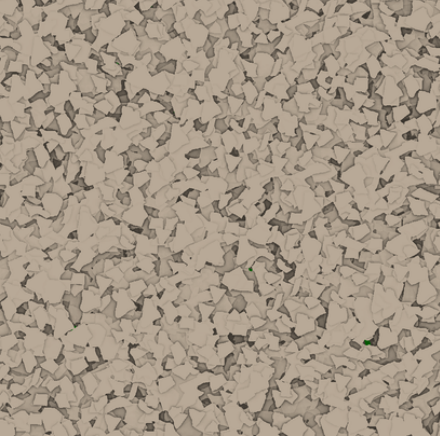

5116

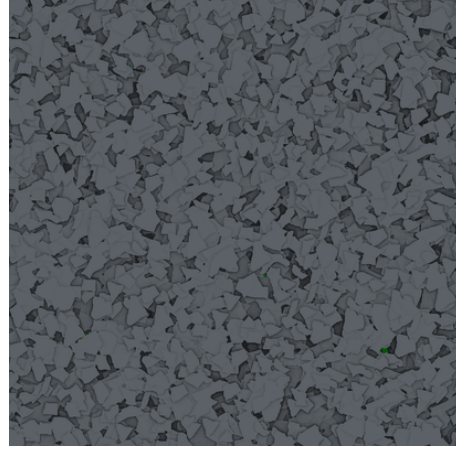

5920

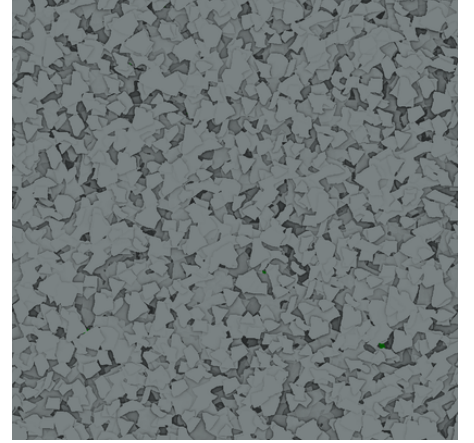

1415

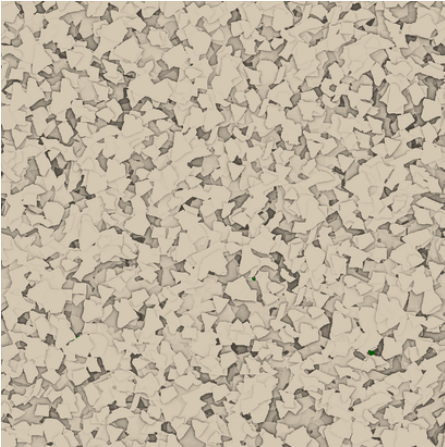

1780

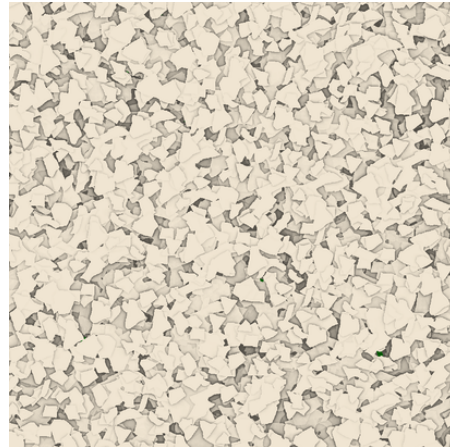

1425

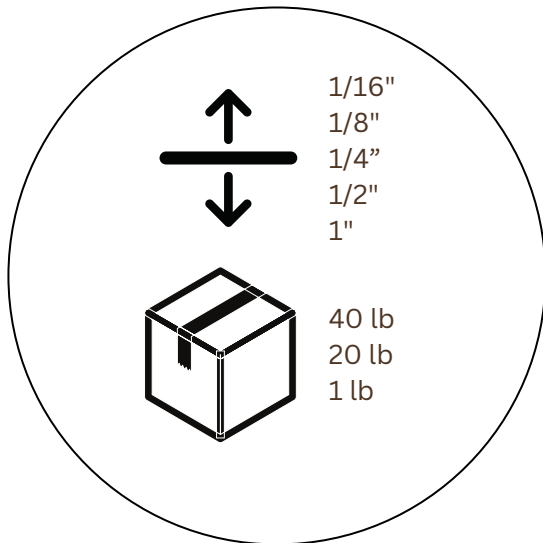

ŞAP-MERSAN LTD STI
KARESİ VD 8000256063
Pasa Alanı Mh 30 Sk No 11 Karesi Balıkesir TÜRKİYE
www.likitgranit.com
info@akrikor.com +90 541 427 6270



Epoxy floor coatings are a popular choice for industrial and commercial applications, offering numerous advantages. Here are the top five benefits of using epoxy floor coatings:



1. **Durability and Longevity:** Epoxy coatings are designed to withstand years of use, even in high-traffic areas. They protect concrete floors from wear, cracks, and chemical damage, extending the life of the floor.



2. **Easy Maintenance:** The smooth and seamless surface of epoxy floors makes them easy to clean. Dust and dirt can be easily swept or wiped away, making them hygienic and particularly ideal for food processing or healthcare facilities.

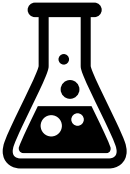

3. **Chemical Resistance:** Epoxy is resistant to oil, gasoline, cleaners, and many other chemicals. This property makes it an excellent choice for garages, factories, and storage facilities where chemicals are frequently used.



4. **Safety:** Its reflective properties enhance lighting, and slip-resistant options make work areas safer. It can also be used to direct traffic flow and delineate safety areas with specific colors and markings.



5. **Aesthetic Appeal:** Epoxy coatings can create aesthetically pleasing floors with a wide range of colors, patterns, and shimmering effects. They also provide a professional and clean appearance with a glossy surface.