

# **DEVELOPMENT STANDARDS**

For Water Main Extensions

And

Fire Hydrants

## Mt. View-Edgewood Water Company

The standards within are presented to inform the Developer/Contractor of the minimum requirements necessary in the construction and acceptance of water facilities within the Mt. View - Edgewood Water Company service area.

Mt. View – Edgewood Water Company does not assume responsibility for keeping this material current. The Water Company should be consulted in case of doubt on the applicability of any item(s) within. Some of the information contained within is based on governmental codes and ordinances, and industry standards and are subject to change in the event that such governing codes and ordinances are changed.

# **DEVELOPMENT STANDARDS**

For Water Main Extensions

And

Fire Hydrants

## TABLE OF CONTENTS

SECTION I	GENERAL CONDITIONS
SECTION II	DEVELOPER'S AGREEMENT
SECTION III	GENERAL STANDARDS
SECTION IV	DEVELOPMENT DETAILS

SECTION I  
GENERAL CONDITIONS

## SECTION I GENERAL CONDITIONS

### 1. DEFINITIONS

To make clear the meaning and intent of the words: Water Company, Water Company's Engineers, Developer, Contractor, and Contract Documents, as used in these standards, the following definitions are given:

Water Company: Mt. View – Edgewood Water Company, Pierce County, Washington, a private corporation existing under and by virtue of the laws of the State of Washington.

Water Company's Engineers: Members of the licensed consulting organization which is retained by the Water Company.

Inspector: The person designated by the Water Company to inspect work.

Assignment of Account: A type of maintenance guarantee provided to the Water Company by the developer to correct defects in labor and/or materials for a period of two (2) years after final acceptance by the Water Company.

Developer: The person, persons, firm or corporation entering into agreement with Mt. View – Edgewood Water Company for the installation and/or extension of a water facility to serve a lot or plat development. The term also includes the Developer's agents and employees and Contractor.

Contractor: The person, persons, firm or corporation assigned by the developer to perform the work required by project plans and specifications to construct the water facility within the Water Company service area. The term also includes the Contractor's agents and employees.

Developer/Contractor: Use of either "Developer" or "Contractor" in this document shall be understood to be interchangeable, one for the other, wherein both are responsible for compliance, and the developer assumes full and final responsibility unless a division of responsibility through the use of a contract, performance bond, insurance, etc., is established.

Contract Documents: These shall consist of the following, and in case of conflicting provisions the text material shall have precedence:

- A. Developer's Agreement for Water Main Extensions
- B. Plans
- C. Standard Detail
- D. Specifications-Conditions and Standards of the Contract to include system testing

## Mt. View-Edgewood Water Company

- E. Addenda
- F. Change Orders
- G. General Conditions
- H. "As Built" Documents
- I. Easements

### 2. STATUS OF ENGINEER AND INSPECTOR

The Water Company's Engineer or Inspector shall serve as an agent of the Water Company, and in conjunction with the Water Company's General Manager, have the authority to accept or reject the work performed by the Developer/Contractor for facilities within the Water Company service area.

### 3. INSPECTION OF WORK AND DEPOSIT

The Developer shall give the Water Company timely notice that the work, or any part thereof, which has been constructed within the Water Company's service area, is ready for inspection. In no event shall the work or any portion thereof, be covered or placed into operation until the Water Company's representative has completed an inspection and approved the same.

If any work should be covered without prior inspection and approval by the Water Company, it must, if required by the Water Company, be uncovered for examination at the Developer's expense.

A sum computed for each inspector day (8 hours), as estimated by the Water Company General Manager, shall be paid by the Developer prior to construction. The "Inspection Fee" hourly rate is determined utilizing the current fee schedule. An inspector day shall be each day or part thereof during which construction is in progress. If the actual number of inspection days so required exceeds the General Manager's estimate, the Developer shall pay the Water Company upon demand for each additional inspector day. The Water Company may stop the work until such payment is made. In addition to the number of inspection days, an additional amount will be collected at the same time to cover the expense of various fees such as, but not limited to, meetings, laboratory expenses, water purchases, engineering expenses, equipment rental, parts, and additional labor as needed. If the actual number of inspector days so required is less than the General Manager's estimate, or if the additional deposit amount exceeds actual costs, the Water Company will reconcile the deposit to the final costs, and refund the difference.

The Water Company and its representatives shall at all times have access to the work whenever it is in preparation or progress, and the Developer shall provide proper facilities for such access and for such inspection.

The Developer shall make such reasonable tests of the work, at the Developer's expense, as the Water Company shall request.

If the specifications, the Water Company's instructions, laws, ordinances, or any public authority shall require any work to be specially tested or approved, the Developer shall give the Water Company or its representative timely notice of its readiness for inspection and, if the inspection is by other authority than the Engineer, the date fixed for such inspection.

All inspections by the Water Company will be made with all reasonable promptness but, in no event, shall the lack of prompt inspections be construed to allow the Developer to cover the work or any portion without inspection.

#### 4. FINAL INSPECTION AND ACCEPTANCE

All materials and completed work will, before acceptance by the Water Company, be subject to final inspection by the Water Company. The Water Company shall have the right to subject all machinery, equipment, and work to such tests as will, in their opinion, assist in determining whether the contract has been faithfully performed.

#### 5. MATERIALS AND FACILITIES

Unless otherwise stipulated, all material utilized for water system construction within the Water Company shall be new, and both workmanship and materials shall be of good quality. The Developer shall, if required, furnish satisfactory evidence as to the type and quality of materials.

The Developer shall at all times enforce strict discipline and good order among the employees, and shall not employ any person not skilled in the work assigned.

#### 6. ROYALTIES AND PATENTS

The Developer shall pay all royalties and license fees. The Developer shall defend all suits and claims for infringement of any patent rights and shall save the Water Company harmless from loss on account thereof.

#### 7. SURVEYS, PERMITS, AND REGULATIONS

The Developer shall furnish and pay for all surveys, licenses, permits, easements, and right-of-way.

The Developer shall give all notices and comply with all laws, ordinances, rules, and regulations bearing on the conduct of the work.

## 8. POINTS AND INSTRUCTIONS

The Developer shall carefully preserve bench marks, reference points and stakes, and in the case of destruction shall be charged with the resulting expense for re-establishing such points, and shall be responsible for any mistakes that may be caused by their absence or disturbance.

## 9. PROTECTION OF WORK AND PROPERTY

The Developer shall continuously maintain adequate protection of all work from damage and shall protect the property of others from injury or loss arising in connection with the work. Developer shall make good any such damage, injuries, or loss. Developer shall adequately protect the adjacent property as provided by law and the Contract Documents. Developer shall provide and maintain all passage ways, guard fences, lights and other facilities for protection required by public authority or local conditions. Developer shall bear the risk of loss or damage for all finished or partially finished work until the entire project is completed and accepted by the Engineer.

## 10. EXISTING UTILITIES

The Contractor shall investigate and locate all buried utilities or obstructions in the construction area prior to construction of new water facilities. The contractor shall coordinate with the Water Company, power, telephone, fiber optics, gas companies and all other affected utilities for filed location of the respective existing facilities.

## 11. REPLACING IMPROVEMENTS

Whenever it is necessary in the course of construction to remove or disturb culverts, driveways, roadways, pipelines, or other existing improvements, they shall be replaced to a condition equal to that existing before they were so removed or disturbed. If it is necessary to trench through lawns, the sod shall be removed before trenching and replaced after backfilling.

## 12. ACCESS

Bridging shall be provided across private driveways and roadways, during the period that trenches must be open, in such a manner as not to constitute a hazard to the people who use them. All construction operations shall be conducted in such a manner as to interfere as little as possible with the normal procedure of traffic.



### 13. DEFECTS AND THEIR REMEDIES

If the work or any part thereof performed by the Developer/Contractor shall be deemed by the Water Company's representative as not in conformity with the Water Company's Standards, the Developer shall rebuild or otherwise remedy such defects prior to being accepted by the Water Company.

The Developer shall be responsible for correcting all defects in workmanship and material appearing within two years after completion and acceptance of the project. The Developer shall start work to remedy such defects within seven (7) days of notice of discovery thereof by the Water Company and shall complete such work within a reasonable time. In emergencies, where damage may result from delaying or where loss of service may result, such corrections may be made by the Water Company, in which case all costs shall be borne by the Developer. In the event the Developer does not accomplish correction at the time specified, the work shall be otherwise accomplished and the cost of same shall be paid by the Developer.

### 14. USE OF COMPLETED PORTIONS

The Water Company shall have the right to take possession of and use any completed or partially completed portions of the work, notwithstanding that the time may not have expired for completing the entire work or such portions, which will not interfere with the Contractor performing the remaining work. Such taking possession and use shall not be deemed an acceptance of any work not completed in accordance with the Contract Documents or Water Company Standards.

### 15. LIMITS OF LIABILITY, SUMMARY OF COVERAGE, AND INDEMNITY

The Contractor shall carry liability and property damage insurance covering all work during Project construction, including that done by subcontractors. The Water Company must be listed as Additional Insured and be a Certificate Holder. This insurance shall also protect the Water Company from any contingent liability prior to Project acceptance.

The minimum limits of liability for the below mentioned exposures will be \$1,000,000 property damage, \$1,000,000 Bodily Injury, and the amount of the Contract Price when direct property damage is involved.

The aforementioned general public liability insurance shall name the Owner as a beneficiary thereof and a certificate of such insurance shall be filed by the Contractor with the Owner prior to the commencement of construction. Such certificate(s) shall contain a clause requiring a minimum of ten (10) days notice to the Owner by the insurance company before the cancellation thereof.

A. Contractor's Liability and Property Damages

- (1) Workman's Compensation and Employer's Liability
- (2) Public Liability, Bodily Injury, and Property Damage
- (3) Automobile, Truck Public Liability, Bodily Injury & Property Damage
- (4) Comprehensive, Storm, Vandalism, etc.
- (5) Fire

B. Owner's Protective Liability and Property Damage

- (1) Contingent Liability
- (2) Bodily Injury
- (3) Fire
- (4) Comprehensive, Storm, Vandalism, etc.

C. Contractual Liability and Property Damage

- (1) Contractor's Agents and Subcontractors
- (2) Owner's Agents
- (3) Others not in the Employ of Contractor or Owner

The Developer shall indemnify and save harmless the Water Company from and against all losses and all claims, demands, payments, suits, actions, recoveries, and judgments of every nature and description brought or recovered against the water Company by reason of any act or omission of the Developer, and his/her agents or employees, in the execution of the work or in the guarding of it.

16. SAFETY

Contractor expressly agrees that it shall be solely responsible for supervising its employees, that it shall comply with all rules, regulations, orders, standards, and interpretations promulgated pursuant to the Occupational Safety and Health Act of 1970 {and to the Occupational and Safety Act of the State of Washington}, including, but not limited to, training, provision of personal protective equipment, adherence to all appropriate lock out/tag out procedures, and providing all notices, material safety data sheets, labels, etc. required by the right-to-know standard.

17. RIGHTS OF VARIOUS INTERESTS

Wherever work being done by the Water Company's employees or agents or by other developers is contiguous to work performed by the Developer, the respective rights of the various interests involved shall be established by those involved to secure the completion of the various portions of the work in general harmony.

18. SANITATION

Necessary sanitation conveniences for the use of workers on the job, properly secluded from public observation, shall be provided and maintained by the developer.

19. CLEAN-UP

The Developer shall keep the construction site reasonably clean during the progress of the work.

The Developer shall backfill the trenches, clean out ditches that may have been filled during the work, replace damaged surfacing, remove surplus materials and trash, dispose of brush, repair all damages, and otherwise leave the job in a neat and orderly condition.

20. CONSTRUCTION CONFORMANCE

In addition to meeting the standards and conditions of the Mt. View – Edgewood Water Company, all construction shall be in conformance with the requirements of the City of Edgewood, Department of Social and Health Services, Department of Ecology, Washington State Department of Transportation and the American Public Works Association.

SECTION II  
DEVELOPER'S AGREEMENT

**MT. VIEW – EDGEWOOD WATER COMPANY APPLICATION AND AGREEMENT TO INSTALL HYDRANTS AND/OR CONSTRUCT EXTENSION TO WATER COMPANY SYSTEM**

The undersigned, “Developer” herein, hereby makes application to Mt. View – Edgewood Water Company, “Water Company” herein, for permission to install a hydrant and/or construct and connect a private “extension” to the Water Company’s existing system as herein provided. The term “Extension” shall apply herein wherever the Developer is extending the Water Company system. If this application is accepted, the undersigned, in consideration of the mutual promises and covenants herein contained, agrees to the terms and conditions of this Developer Extension Agreement as follows:

**1. LOCATION OF EXTENSION**

**A. Water**

The proposed water system extension will be installed in streets and other approved rights-of-way and/or easements and shall be for the use and benefit of the property hereinafter described, which property is owned by Developer and/or other owners for whom Developer is acting as agent. Any such owners have joined in this application and are designated on the signature page hereof.

**B. Description**

The legal description of the real property upon which the Extension will be installed is attached hereto as Exhibit A.

**2. WARRANTY OF AUTHORITY**

Developer and any additional owners warrant that they are the owners of the property described in this Agreement. Developer shall, upon request of Water Company, provide a title report to Water Company establishing that the parties executing this Agreement are the owners of all the real property described herein.

**3. DESCRIPTION OF EXTENSION**

**A. Water**

The Extension will consist of approximately \_\_\_\_\_ lineal feet of water pipe and appurtenances and shall be installed in accordance with this Agreement and with such Plans as Developer’s Engineer may prepare in conformity with Water Company specifications and approved by the Water Company.

4. PREPARATION OF PLANS BY DEVELOPER'S ENGINEER

- A. Developer shall have its own engineer prepare the Plans for the extension according to Water Company Specifications.
- B. Prior to preparation of the Plans, Developer must:
  - 1. Obtain official preliminary plat approval for Developer's project using a minimum scale of one (1) inch equals fifty (50) feet.
  - 2. File with the Water Company the road and storm sewer plans and profiles for the project; and
  - 3. File with the Water Company a contour map of the project with contour intervals of five (5) feet or less using a scale of one (1) inch equals fifty (50) feet. All data to be based on USCGS data.
- C. Upon completion of 4.B. above, a pre-design meeting shall be held with Water Company and with Developer and Developer's Engineer in attendance. It is expected that this meeting will occur approximately ten (10) working days after completion of B above. It is the obligation of Developer to arrange for the conference and the attendance of concerned parties.
- D. At the pre-design meeting, the Developer's Engineer shall submit to Water Company a conceptual plan for the utility development of the project.
- E. Upon preliminary review of the conceptual plan, Developer's Engineer shall prepare and submit to the Water Company a preliminary design and Plan for review and approval by the Water Company. **The Developer pays a Plan Review Fee per current Fee Schedule.** The Water Company shall have the right to require changes in the preliminary design and Plan as may be deemed necessary. All designs and plans prepared by Developer's Engineer shall be prepared in accordance with the Water Company Development Details.
- F. Upon approval of the preliminary design and Plan by the Water Company, Developer's Engineer shall prepare a proposed final Plan and submit three (3) copies of the proposed final Plan to the Water Company for review along with the prescribed Plan Review fee. Upon receipt of the proposed final Plan, Water Company shall have the right to require such changes to the proposed final Plan as may be deemed necessary.
- G. Upon completion of all required changes to the final Plan, the Water Company Board of Directors shall consider the final Plan for approval at a regularly scheduled Board meeting. The Water Company Board of

## Mt. View-Edgewood Water Company

Directors shall have the right to approve, reject, or require changes to the final Plan as may be deemed necessary.

- H. Upon approval of the final Plan by the Water Company Board of Directors, the plans shall be dated and stamped approved. Plan approval is valid for one (1) year.
- I. The Developer shall be responsible for procuring all applicable permits. Should changes to the Plan be required in order to receive said permits and approvals, Developer's Engineer shall make all changes as required and resubmit the plans to the Water Company. **Additional plan review fees will apply.**
- J. The Developer's Engineer shall provide the Water Company with one (1) full size copy of the as-builts within 30 days after completion of project. Electronic survey data shall also be supplied. The electronic data shall include all water system components (valves, hydrants, PRVs, meters, air vacs, blow-offs, and any other components) and relevant structures. The survey location of the points shall be based on the Washington State Plane North coordinate system, NAD 83/91 horizontal datum and NAVD 88 vertical datum. The survey data can be included as point blocks in a digital ACAD file, release 14 or later. All points must be attributed to include the type of water system component (size, type, mfg, and year) and type of structure.

### 5. EASEMENTS

Upon approval of the final Plan by the Water Company Board of Directors, and prior to commencement of construction, the developer shall obtain all necessary easements without cost to the Water Company. The developer shall use the Water Company's standard easement form found at the end of this section. Wherever a main is to be laid other than in a public street, a permanent easement of not less than seven and one half (7-1/2) feet on each side of the centerline, shall be provided. The developer shall supply the Water Company with the supporting data necessary to verify the location of the easement(s). If legal services are required by the Water Company in connection with the easement(s), other than formal review, the cost of such services shall be reimbursed by the Developer to the Water Company on demand and before acceptance of the extension.

### 6. WARRANTIES OF DEVELOPER

The bill of sale to be provided by Developer to Water Company shall contain the following warranties with Water Company as beneficiary:

- A. Developer is the owner of the extension, the same is free and clear to all encumbrances and Developer has good right and authority to transfer title thereto to the Water Company and will defend the title of Water Company

against the claims of all third parties claiming to own the same or claiming any interest therein or encumbrance thereon; and

- B. That all bills and taxes relating to the construction and installation of the Extension have been paid in full and that there are no lawsuits pending involving this project. The undersigned further warrants that in the event any lawsuit is filed as a result of, or involving, this project the undersigned will undertake to defend the lawsuit and will accept responsibility for all costs of litigation, including costs on appeal, and will hold Water Company harmless on any judgment rendered against Water Company; and
- C. That all laws and ordinances respecting construction of this project have been complied with, and that the system extension is in proper working condition, order and repair, and is adequate and fit for its intended purpose and that it has been constructed in accordance with the conditions and standards of the Water Company; and
- D. For a period of two (2) years from the date of final acceptance of the extension by Water Company, the extension and all parts thereof shall remain in proper working condition, order and repair. Developer shall repair or replace, at its expense, any work or material which may prove to be defective during the period of the warranty.

In addition, Developer shall obtain warranties and guaranties from its subcontractor and/or suppliers where such warranties or guaranties are specifically required in the Agreement. When corrections of defects occurring within the warranty period are made, Developer shall further warrant corrected work for two (2) years after acceptance of the corrected work by Water Company.

#### 7. CORRECTION OF DEFECTS OCCURRING WITH WARRANTY PERIOD

When defects in the extension are discovered within the warranty period, Developer shall start work to remedy any such defects within four (4) calendar days of notice by Water Company and shall complete such work within a reasonable time. In emergencies, where damages may result from delay and where loss of service may result, corrections may be made by Water Company upon discovery, in which case the cost thereof shall be borne by Developer. In the event Developer does not commence and/or accomplish corrections within the time specified, the work may be accomplished by Water Company at its option, and the cost thereof shall be paid by Developer.

Developer shall be responsible for any expenses incurred by the Water Company resulting from defects in Developer's work, including actual damages, costs of materials and labor expended by Water Company in making repairs and the cost of engineering, inspection and supervision by the Water Company.



## 8. PERFORMANCE GUARANTEE

Developer shall, if requested, furnish to Water Company prior to the preconstruction conference a performance guarantee of a type and in a form as determined by Water Company, in its sole discretion, in an amount equal to the engineer's estimated cost of the Extension or contractor bid price. The performance guarantee shall require completion of all work in accordance with the Agreement, the Plans and Specifications and other requirements of Water Company, within a period of twelve (12) months from the date of acceptance of the Plans by the Water Company. The Water Company in its sole discretion may also require a payment bond of a type and in a form as determined by the Water Company requiring the payment by Developer of all persons furnishing labor and materials in connection with the work performed under the Agreement, and shall hold Water Company harmless from any claims therefrom. Any payment bond required by Water Company shall be provided to Water Company prior to the preconstruction conference or following commencement of work as a condition of Water Company granting final acceptance of the work referenced herein. No third person or party shall have any rights under any performance guarantee that the Water Company may require from the Developer and such performance guarantee is provided entirely for the benefit of Water Company and Developer and their successors in interest.

## 9. ASSIGNMENT OF ACCOUNT

Acceptance by Water Company shall not relieve Developer of the obligation to correct defects in labor and/or materials as herein provided and/or the obligations set forth in applicable paragraphs hereof. Prior to acceptance of the extension by Water Company and the transfer of title to such extension(s) as set forth herein, Developer shall furnish to the Water Company an Assignment of Account which shall continue in force from the date of acceptance of said extension for a period of two (2) years from the date of acceptance of the system and transfer of title. The Assignment of Account shall be in an amount equal to ten (10) percent of the cost of said extension, including tax, but not less than two thousand dollars (\$2,000.00). The Water Company shall review the submitted construction costs and determine the amount of the maintenance bond. An Assignment of Account is a two (2) year Certificate of Deposit held at Columbia Bank, Edgewood, WA in the names of the Water Company and the Developer; which allows the Water Company access to the funds if necessary to correct defects (Developer will first be given an opportunity to correct defects in a timely manner). At the end of the two (2) year period and after final inspection and release, the Developer recovers remaining funds plus accrued interest.

## 10. LIMITATION OF PERIOD OF ACCEPTANCE

The extension shall be completed and accepted within twelve (12) months of the date of acceptance of the Plans by the Water Company. If the extension is not completed and

## Mt. View-Edgewood Water Company

accepted within the twelve (12) month period, then this Agreement and all of Developer's rights herein shall terminate and cease. No extension of the time for completion of the Agreement shall be allowed. In the event the Agreement terminates, Developer shall be required to make a new pre-application and new application for extension agreement to Water Company. Any such new agreement entered into between Water Company and Developer pursuant to a new application shall be subject to any new or amended resolutions, policies, or standards and specifications which have taken effect since the execution of the terminated agreement.

If Developer abandons the extension project during twelve (12) months or shall fail to complete the extension within that period, Developer may be deemed, at Water Company's sole option and election to have transferred and conveyed to Water Company any portion of the extension which has been completed.

### 11. FINAL ACCEPTANCE – CONDITIONS PRECEDENT

Compliance with all terms and conditions of this Agreement, the Plans and Specifications prepared hereunder and other Water Company requirements shall be a condition precedent to Water Company's obligation to allow connection to the Water Company's system, to accept the bill of sale to the extension, and to Water Company's agreement to maintain and operate the extension and to provide service to the real property that is described in this Agreement.

Water Company shall not be required to allow any connection to Water Company's system for any portion of the real property described in this Agreement if there are any fees or costs unpaid to Water Company under this Agreement or there are other fees arising under other Water Company requirements which are unpaid.

Water Company shall not be obligated to provide service to the property described in this Agreement if construction by third parties of facilities to be deeded to Water Company has not been completed and title accepted by Water Company if such third party facilities are necessary to provide service to the property described in this Agreement.

Water Company shall not be obligated to allow service connections to its system until all membership fees and other charges in effect on the date of application for service have been paid.

Water Company will accept title to the extension at such time as all work which may, in any way, affect the lines constituting the extension has been completed, and any damage to said extension which may exist has been repaired, and Water Company has made final inspection and given its approval to the extension as having been completed in accordance with the Agreement, the Plans and Specifications and other requirements of Water Company.

## 12. PROCEDURE FOR ACCEPTANCE

Acceptance of title to the extension will be made by motion of the Board of Directors of Water Company. Prior to such acceptance, an executed Bill of Sale (Appendix F) containing the warranties required by this Agreement shall be executed by Developer and any additional owners and delivered to Water Company. There will be no conditional acceptance or acceptance for use and operation.

## 13. EFFECT OF ACCEPTANCE

Acceptance by Water Company shall cause the extension to be a public system subject to the control, use and operation of Water Company and all regulations, conditions of service, and service charges the Water Company determines to be reasonable and proper, and subject to the laws of the State of Washington.

## 14. RATES AND CHARGES

The property described in this Agreement shall be subject to all rates and charges established by the Water Company.

## 15. SUBCONTRACTING

Developer is fully responsible for the acts and omissions of subcontractors and persons employed, directly or indirectly, by subcontractors, as well as the acts and omissions of persons directly employed by Developer.

## 16. NO ASSIGNMENT WITHOUT WATER COMPANY APPROVAL

Developer's rights and responsibilities arising out of this Agreement are not assignable unless Water Company's prior consent is obtained. Written documents, as required by Water Company, of any Water Company approved assignment shall be filed with Water Company by the Developer at the time of any assignment.

## 17. GENERAL PROVISIONS, TECHNICAL DETAILS, AND SPECIFICATIONS

The Water Company Development Standards, Sections I, II, III and IV, as currently adopted or hereafter amended, are incorporated herein by this reference.

18. REMEDIES AVAILABLE TO THE WATER COMPANY

In the event Developer fails to pay any of the extension fees and charges and fines referenced herein when due as determined by Water Company, the charge or fine shall then be delinquent and shall accrue interest at the highest legal rate per annum until paid. In addition to any other remedies available to Water Company, Water Company shall be entitled to file a lien against the real property referenced herein in the event of nonpayment and to foreclose such lien pursuant to RCW 56.16.100-110 and RCW 57.08.080-090, as revised or amended.

19. NOTICE

Any notice required by this Agreement to be given by Water Company to Developer shall be given as follows:

Name: \_\_\_\_\_ Phone: \_\_\_\_\_

Address: \_\_\_\_\_

20. COMPLETE AGREEMENT

This Agreement, and the Plan(s) approved by Water Company constitutes the entire Agreement between Developer and Water Company with respect to the rights and responsibilities of both parties in regard to project referred to herein. For purposes of identification, this Agreement shall be assigned a number by the Water Company, which number shall be endorsed on the first page of the Agreement. This Agreement may be changed in writing only upon mutual agreement of the Directors of the Water Company and Developer.

ACCEPTANCE OF THIS APPLICATION BY THE WATER COMPANY CONSTITUTES A CONTRACT WITH THE APPLICANT, THE TERMS OF WHICH ARE EACH PARAGRAPH OF THIS AGREEMENT, THE WATER COMPANY DEVELOPMENT STANDARDS, AND THE EXTENSION DESIGN DRAWINGS APPROVED BY THE WATER COMPANY.

Dated this \_\_\_\_\_ day of \_\_\_\_\_, 20\_\_\_\_\_

By \_\_\_\_\_ Owner

Development Name & Parcel # \_\_\_\_\_

STATE OF WASHINGTON }  
                                       } ss  
 COUNTY OF                                  }

I certify that I know or have satisfactory evidence that \_\_\_\_\_ signed this instrument and acknowledge it to be \_\_\_\_\_ free and voluntary act for the uses and purposes mentioned in the instrument.

Dated:\_\_\_\_\_

\_\_\_\_\_  
 NOTARY PUBLIC in and for the  
 State of Washington

My Commission Expires:\_\_\_\_\_

Mt. View-Edgewood Water Company

THE FOREGOING APPLICATION OF \_\_\_\_\_

Accepted this \_\_\_\_\_ day of \_\_\_\_\_, 20\_\_\_\_\_

MT-VIEW EDGEWOOD WATER COMPANY

BY \_\_\_\_\_

It's General Manager

STATE OF WASHINGTON }  
  } ss

COUNTY OF }  
  }

I certify that I know or have satisfactory evidence that \_\_\_\_\_ is the person who appeared before me, and said person acknowledged that he signed this instrument, on oath stated that he was authorized to execute said instrument and acknowledged it as the General Manager of Mt. View – Edgewood Water Company, a private corporation, to be the free and voluntary act of such corporation for the uses and purposes mentioned in the instrument.

DATED: \_\_\_\_\_

\_\_\_\_\_  
NOTARY PUBLIC in and for the  
State of Washington

My Commission Expires: \_\_\_\_\_

BILL OF SALE

THE UNDERSIGNED hereby conveys and transfers to MT. VIEW-EDGEWOOD WATER COMPANY, INC; the following described property:

\_\_\_\_\_  
\_\_\_\_\_  
\_\_\_\_\_  
\_\_\_\_\_  
\_\_\_\_\_

Parcel Number(s): \_\_\_\_\_

This conveyance is made in consideration of the Company’s agreement to provide routine maintenance of said property and to provide water services pursuant to the Company’s regulations, which may be amended from time to time.

The undersigned and its successors and assigns covenants and agrees to and with the Company, its successors and assigns, that the undersigned is the owner of said property and had good right and authority to sell the same and that it will, and does, hereby warrant and agree to defend the sale of said property to the Company, its successors and assigns, against all and every person or persons whomsoever lawfully claiming or to claim the same.

The undersigned further guarantees that the property is fit for purposes intended, i.e., as for use as a water distribution system including distribution and supply lines adequate for the service intended and has been constructed in accordance with the conditions and standards of the Company.

The undersigned covenants and agrees with the Company to replace, repair and correct any defect in work or materials in respect to the personal property subject to this Bill of Sale arising during a period of two (2) years from date hereof, without cost to the Company.

DEVELOPER: \_\_\_\_\_  
Company Name  
\_\_\_\_\_  
Owner  
\_\_\_\_\_  
Title  
\_\_\_\_\_  
Date

ACCEPTED: \_\_\_\_\_  
General Manager Date

## MT. VIEW – EDGEWOOD WATER COMPANY ASSIGNMENT OF ACCOUNT

I/We hereby establish our Assignment of Account in favor of the Mt. View-Edgewood Water Company in the amount of \$\_\_\_\_\_. This Assignment of Account is issued in connection with construction of the project known as \_\_\_\_\_ located at \_\_\_\_\_ to guarantee correction of defects in labor and/or materials and perform maintenance.

It is understood that the nature and extent of the water system improvements are defined by the approved plans, and conditions contained in the Mt. View-Edgewood Water Company Development Standards for Water Main Extensions and/or Development Standards for Fire Hydrants.

If, in the determination of the General Manager the above-referenced improvements are not free from defect or does not perform as required by the approved plans, conditions, and applicable standards at the above location for two (2) years from the date of acceptance of the system and transfer of title, no later than **two years**, Columbia Bank agrees to pay to the Mt. View-Edgewood Water Company the sum of \$\_\_\_\_\_, or such amount as required by the Mt. View-Edgewood Water Company to complete or repair said project in accordance with approved plans, conditions, and applicable standards. Payment shall be made within five (5) days of receipt of written request from the Mt. View-Edgewood Water Company.

This Assignment of Account shall not expire until released in writing by the Mt. View-Edgewood Water Company, which release shall be provided upon request when the required improvements have been completed as provided above.

_____ Date	By: _____ (to be signed by authorized representative of lending institution)
_____ Bank Name	_____ Name (Please Print)
<u>Milton-Edgewood</u> Bank Branch	_____ Title
_____ Account Number	_____ Address
_____ Account Depositor	_____ City, State, Zip



## Mt. View - Edgewood Water Company

### DEVELOPER EXTENSION CHECKLIST

Name of Project \_\_\_\_\_ Project # \_\_\_\_\_

Developer/Owner \_\_\_\_\_

Contact Person \_\_\_\_\_ Phone \_\_\_\_\_

Engineer \_\_\_\_\_ Phone \_\_\_\_\_

Contractor \_\_\_\_\_ Phone \_\_\_\_\_

Location \_\_\_\_\_

Residential       Multi-Family       Commercial       Mixed Use

#### **A. Water Availability Certificate:**

Date Issued \_\_\_\_\_

#### **B. Developer Extension Agreement (DEA):** (Included within the “Mt.View-Edgewood Water Company Development Standards for Water Main Extension” manual).

1.  Submit Full Size Plat or Site Map 1”+50’ With Contours - Date \_\_\_\_\_

2.  Calculate Inspection/Sampling Fee Deposit \$ \_\_\_\_\_

3.  Submit Inspection/Sampling Fee Deposit - Date \_\_\_\_\_ \$ \_\_\_\_\_

4.  Submit Developer Extension Agreement - Date \_\_\_\_\_

5.  Off-Site Requirements \_\_\_\_\_

6.  Execute Developer Extension Agreement - Date \_\_\_\_\_

**C. Design /Design Review:**

1.  Pre-Design Meeting to Discuss Requirements - Date \_\_\_\_\_
2.  Submit Plan Review Fee - Date \_\_\_\_\_ Amount \$ \_\_\_\_\_
3.  Submit Scale Map 1”+50’ of Final Lot Layout - Date \_\_\_\_\_
4.  Submit Contour Map with 5’ or Less Intervals - Date \_\_\_\_\_
5.  Submit Two Copies of Preliminary Plan - Date \_\_\_\_\_
6.  Submit Three Copies of Final Plan for Approval - Date \_\_\_\_\_
7.  Plan Approval; Return One Stamped Copy - Date \_\_\_\_\_
8.  Approval of Submittals - Date \_\_\_\_\_

**D. Required Prior to Pre-Construction Meeting:**

1.  Insurance Certificate Submitted - Date \_\_\_\_\_
2.  Contractor’s State of WA License and Registration Submitted - Date \_\_\_\_\_
3.  Right-of-Way Permit Issued - Date \_\_\_\_\_
4.  All Easements Executed, Recorded and Delivered - Date \_\_\_\_\_
5.  Approval of Plans by Fire Marshal - Date \_\_\_\_\_

**E. Required Prior to Construction:**

1.  Sections A, B, C, & D Completed - Date \_\_\_\_\_
2.  Pre-Construction Meeting Held - Date \_\_\_\_\_
3.  Notify Water Company One Week Prior to Start of Construction - Date \_\_\_\_\_
4.  Construction Stakes in Place - Date \_\_\_\_\_

**F. Required Prior to Acceptance of Project:**

1.  Pressure Test Completed/Passed - Date \_\_\_\_\_
2.  Water Quality Samples Passed - Date \_\_\_\_\_
3.  Final Construction Punch List Completed - Date \_\_\_\_\_
4.  Submit Construction Costs to Water Company - Date \_\_\_\_\_
5.  Prepare Bill of Sale - Date \_\_\_\_\_
6.  Executed Bill of Sale Submitted to Water Company - Date \_\_\_\_\_
7.  Submit Copy of Recorded Plat - Date \_\_\_\_\_
8.  Submit Final Construction As-Built Drawings and CAD File - Date \_\_\_\_\_
9.  Post Two (2) Year Assignment of Account - Date \_\_\_\_\_
10.  Reconcile Fee Deposit to Final Costs - Date \_\_\_\_\_
11.  Final Bill Paid - Amount \$ \_\_\_\_\_ - Date \_\_\_\_\_
12.  Approval and Acceptance of Construction/Project - Date \_\_\_\_\_

**G. Required Prior to Release of Assignment of Account:**

1.  Final Inspection Two Years from Project Acceptance - Date \_\_\_\_\_
2.  Contractor Notified of Necessary Repairs and/or Restoration - Date \_\_\_\_\_
3.  Completion of Repairs/Restoration - Date \_\_\_\_\_
4.  Release of Assignment of Account - Date \_\_\_\_\_

Mt. View-Edgewood Water Company

When recorded please return to:

MT. VIEW-EDGEWOOD WATER COMPANY  
11610 32<sup>ND</sup> STREET EAST  
EDGEWOOD, WA 98372

EASEMENT FOR WATER MAIN

**Grantor: Legal Owner Name(s)**

**Address: Site Address**

**Grantee: Mt. View-Edgewood Water Company**

**Description of easement** as shown in Exhibit A attached hereto and by this reference made a part hereof. Parcel # (INSERT) located in the XX 1/4 of the XX 1/4 of Section XX, Township 20 North, Range 4 East, in Pierce County, Washington.

**Legal Owner Name(s)** (Grantor), for itself, its successors and assigns, for a valuable consideration the receipt and sufficiency whereof is hereby acknowledged, hereby dedicates, conveys and grants unto the Mt. View-Edgewood Water Company, Inc (Grantee), its successors and assigns, a personal Easement for ingress, egress and utilities under, through and across the property described above.

That said GRANTEE shall have the right without prior institution of any suit or proceeding at law, at times as may be necessary, to enter upon said property and adjoining successors to install, construct, renew, operate and maintain mains and necessary facilities and other equipment for the purposes of serving the property and other properties with water and other utilities service.

Also, the GRANTOR grants to the GRANTEE and to those acting under and for the GRANTEE the use of such additional area immediately adjacent to the above easement as shall be required for the construction of this water pipeline or the lines in the easement. Such additional area is to be held to a minimum necessary for that purpose. Immediately after the completion of the construction and installation or any subsequent entry upon the easement, the GRANTEE shall restore the premises as near as may be to the condition immediately before such construction or entry.

The GRANTOR covenants that access shall not be blocked, that the grade shall not be changed, that no permanent structure shall be erected and no large trees or shrubs shall be planted in the

Mt. View-Edgewood Water Company

area of ground for which the easement in favor of the MT. VIEW-EDGEWOOD WATER COMPANY, INC. has been provided herein.

The GRANTOR hereby agrees to replace at the GRANTOR’S cost, any paving, curbing, concrete, retaining walls, railing, fencing, landscaping or other objects placed in the easement should any repair and/or maintenance be necessary of existing water main and necessary facilities and other equipment owned by Mt. View-Edgewood Water Company, Inc. and/or its successors or heirs.

This easement and the covenants herein shall be covenants running with the land and shall be binding on the successors, heirs and assigns of both parties hereto.

GRANTOR warrants that the GRANTOR has good title to the above property and warrants the GRANTEE title to the easement conveyed herein.

GRANTOR (S): **Name**

**Name**

\_\_\_\_\_  
**(Name)**

\_\_\_\_\_  
**(Name)**

STATE OF WASHINGTON

COUNTY OF PIERCE

On this \_\_\_\_\_ day of \_\_\_\_\_, 20XX, before me the undersigned, a Notary Public in and for the State of Washington, duly commissioned and sworn, personally appeared:

**Legal Owner Name(s)**, to be known to be the individual or individuals described in and who executed the within and foregoing instrument, and acknowledge he (she or they) signed the same as is his (her or their) free and voluntary act and deed, for the uses and purposes therein mentioned.

WITNESS my hand and official seal the day and year first above written.

\_\_\_\_\_

NOTARY PUBLIC in and for the State of  
Washington, residing at,

\_\_\_\_\_

My Commission expires: \_\_\_\_\_

SECTION III  
GENERAL STANDARDS  
FOR  
WATER MAIN EXTENSIONS  
AND  
FIRE HYDRANTS

## 1. OBJECTIVE

*Section III – General Standards for Water Main Extensions and Fire Hydrants* is intended to present information and provide the minimum standards required by Mt. View – Edgewood Water Company (MTVE) for constructed water main extensions and other improvements which are to be acquired and operated by the Water Company.

## 2. GENERAL NOTES

Detailed plans shall be submitted for MTVE's review that delineates the locations, size, and type of the proposed water system development and points of connection.

Project plans must have a horizontal scale of not more than fifty (50) feet to the inch and a vertical scale of not more than five (5) feet to the inch. Plan views must be drawn to a corresponding horizontal scale. Plans must show:

- A. Locations of streets, right-of-ways, existing utilities and water system facilities.
- B. Ground surface, pipe type and size, and water valves and hydrants stationing.
- C. All known existing structures, both above and below ground, which might interfere with the proposed construction, particularly sewer lines, gas lines, storm drains, overhead and underground power lines, telephone lines, and fiber optics.

Computations and other data used for design of the water system shall be submitted to MTVE for approval.

The water system facilities shall be constructed in conformance with the 2012 Standard Specifications for Road, Bridge, and Municipal Construction (M41-10) and current amendments thereto, State of Washington, revised as to form to make reference to Local Governments and as directed by MTVE's requirements and Development Standards.

Material and installation specifications shall contain appropriate requirements that have been established by the industry in its technical publications, such as ASTM, AWWA, WPCF, and APWA standards. Requirements shall be set forth in the specifications for the pipe and methods of bedding and backfilling so as not to damage the pipe or its joints.

The location of the water mains, valves, hydrants, and principal fittings including modifications will be staked out by the Developer. Pipes shall be laid closely to within 0.5 feet of specified grade and alignment. No deviation shall be made from the required line or grade. The developer shall verify and protect all underground and surface utilities encountered during the progress of this work.

Except as otherwise noted herein, all work shall be accomplished as recommended in applicable American Water Works Association (AWWA) Specifications, and according to the recommendations of the manufacturer of the material or equipment concerned.

The method of making joints and the materials used shall be included in the project specifications. Joint specifications shall meet the requirements that have been established by appropriate technical organizations such as ASTM, AWWA, WPCF, and APWA.

Before acceptance of the water system by MTVE, all pipes, assemblies, and other appurtenances shall be cleaned of all debris and foreign material. A 2 lb. per cu/ft foam “swab” shall be used after completed assembly to clean the entire pipe, and to ensure the water main is free of obstructions. After all other work is completed and before final acceptance, the entire roadway, including the roadbed, planting, sidewalk areas, shoulders, driveways, alley and side street approaches, slopes, ditches, utility trenches, and construction areas shall be neatly finished to the lines, grades, and cross sections for a new roadway consistent with the original section.

Prior to final inspection, all pipelines shall be “swabbed”, disinfected, pressure tested, flushed, and pass water quality tests as described below. In addition, the Developer Extension Checklist must be completed.

The Developer shall be required upon completion of the work and prior to acceptance by the MTVE, to furnish MTVE with an acceptable guarantee in the form of an Assignment of Account held at MTVE’s bank covering all material and workmanship for a period of two (2) years after the date of final acceptance and shall make all necessary repairs during that period at his own expense, if such repairs are necessitated as the result of furnishing poor materials and/or workmanship. The Developer shall obtain warranties from the contractors, subcontractors and suppliers of material or equipment where such warranties are required and shall deliver copies to MTVE upon completion of the work.

### **3. GENERAL REQUIREMENTS**

- A. All work and materials shall be in complete accordance with the standards and conditions of MTVE, City of Edgewood, Washington State Department of Health, AWWA, and the American Public Works Association.
- B. Developer shall notify MTVE and receive approval prior to any water shut-off or turn-on affecting the water system a minimum of **48 hours** in advance. **Developer shall not operate any system valves.** Shut-offs are not allowed on Fridays, Federal Holidays, or the day prior to Federal Holidays.
- C. Developer shall investigate and locate all buried utilities or obstructions in the construction area prior to construction of the water main extension. Developer shall coordinate with MTVE, Gas Company, Telephone Company, Power Company, Fiber Optics, City of Edgewood Public Works, and all other affected utilities for field location of the respective existing facilities.



- D. Developer shall call Utilities Underground Location Center, two (2) business days prior to construction for aid in locating any existing underground utilities, as applicable.
- E. All water services shall end within road right-of-way or easements unless otherwise detailed on the approved plans.
- F. Provide thrust blocking at all fittings and bends in accordance with MTVE standards and conditions.
- G. Provide anchor blocking at all up-thrust vertical bends in accordance with MTVE standards and conditions.
- H. Provide bends in field to suit construction and in accordance with pipe manufacturer's recommendations so as not to exceed 50% of the allowable deflection at pipe joints.
- I. All valve marker posts shall be painted blue and marked with the number of valves being referenced.
- J. The constructed water system will not be accepted unless the Plans have been approved by MTVE and until proof of satisfactory installation, hydrostatic pressure test, and disinfection report are received by MTVE. The Developer Checklist shall also be completed prior to acceptance.
- K. Prior to any work being performed, the Developer shall contact MTVE to set forth the proposed work schedule.
- L. Developer shall receive approval from MTVE for materials to be used prior to ordering the materials.**
- M. Cut-in connections shall not be made on Fridays, Federal Holidays, the day prior to Federal Holidays, or weekends. A minimum of 48 hours notice to MTVE and affected customers is required prior to any cut-in connection. Tapping tees, tapping saddles, and tapping valves (if allowed) shall be pressure tested prior to making tap to existing mains.
- N. Prior to construction Developer shall notify MTVE for a pre-construction meeting.
- O. Road restoration shall be per City of Edgewood standards. Developer shall become familiar with all conditions of required permits, and shall adhere to all conditions and requirements. The use of equipment with rubber tires or tracks is recommended on any paved or concrete surface. **Damage to the road surface**

**(public or private) will require rebuilding or replacement from logical seam to logical seam.** The Cities inspector will determine the extent of replacement.

- P. All water mains shall be no more than 4'-0" from finished grade to the bottom of the main.
- Q. Fire hydrants shall be spaced per East Pierce Fire and Rescue and City of Edgewood standards.
- R. All materials shall be new, clean, and undamaged.
- S. Work shall be done only by developers experienced in laying water mains.
- T. Mains shall be laid only in dedicated right of ways or in easements which have been granted to MTVE. A street right of way is normally not considered dedicated until the plat which created it has been filed with the County Auditor.
- U. Meter Setters shall be installed as noted on the approved plan set.
- V. All new construction shall comply with MTVE's Cross Connection Control Program.
- W. All existing and new utilities, storm, etc. shall maintain a minimum clearance of 2'-0" over, 1'-0" below, and 5'-0" on the sides the water main.

#### **4. MATERIALS**

##### **A. Ductile Iron Water Mains and Fittings.**

Water mains to be installed shall be Class 52 Ductile iron pipe manufactured by **Pacific States Pipe** or **U.S. Pipe** for all sizes. All pipes shall be capped at the factory with plastic caps and shipped to the job site with the caps intact. The contractor shall be held responsible to maintain the pipe caps until the pipe is placed in the ditch.

**Any dirty pipe or pipe shipped without caps should be refused by the Developer/Contractor or at a minimum be pressure washed, "swabbed" with chlorine, and re-inspected.** A passing HPC test (count less than 20) is required prior to acceptance of the project by MTVE. Dirty or dusty pipe will fail HPC tests.

The ductile iron pipe shall conform to ANSI Specification A21.51-1976, or AWWA Specification C151-76, and current amendments thereto. Grade of iron shall be a minimum of 60-42-10. The pipe shall be cement lined in accordance with AWWA C104 and the exterior shall be coated with coal tar varnish. Each length shall be plainly marked with the manufacturer's identification, year case, thickness, class of pipe and weight.

## Mt. View-Edgewood Water Company

All pipes shall be carefully checked on delivery, as well as before placing in the trench. Pipe shall be carefully bedded per Standard Detail IV-1, joined and protected.

A 2 lb. per cu/ft foam “swab” complete with rear polyurethane drive seal shall be inserted into the first pipe section and remain until construction is complete. This “swab” shall be used to clean the entire pipeline as described later on in this section.

Type of joint shall be mechanical joint or push-on type, employing a single gasket, such as “Tyton,” except where otherwise calling for flanged ends. Bolts furnished for mechanical joint pipe and fittings shall be high strength cast iron, with a minimum tensile strength of 50,000 psi.

All pipes shall be joined by the manufacturer’s standard coupling, be all of one manufacturer, and be carefully installed in complete compliance with the manufacturer’s recommendation.

Joints shall be “made up” in accordance with the manufacturer’s recommendations. Standard joint materials, including rubber ring gaskets, shall be furnished with the pipe. Material shall be suitable for the specified pipe size and pressures.

The pipe and fittings shall be inspected by the Developer/Contractor for defects before installation. All lumps, blisters and excess coal tar coating shall be removed from the bell and spigot end of each pipe, and the outside of the spigot and the inside of the bell shall be wire-brushed and wiped clean and dry, and free from oil and grease before the pipe is laid.

Every precaution shall be taken to prevent foreign material from entering the pipe while it is being placed in the line. After placing a length of pipe in the trench, the spigot end shall be centered in the bell and pipe, forced home and brought to correct line and grade. The pipe shall be secured in place with select backfill tamped under it. Precaution shall be taken to prevent dirt from entering the joint space. At times when pipe installation is not in progress, the open ends of pipe shall be closed by a water-tight plug. If water is in the trench when work resumes, the seal shall remain in place until the trench is pumped completely dry. No pipe shall be laid in water or when trench conditions are unsuitable.

The new pipe shall be installed as close as possible to the tie-in point to the existing water line and not exceed ten (10) feet.

The cutting of pipe for inserting fittings or closure pieces shall be done in a neat and workmanlike manner, without damage to the pipe or cement lining, and so as to leave a smooth end at right angles to the axis of the pipe. All cuttings shall be removed from the pipe prior to installation. Pipe shall be laid with bell ends facing in the direction of the laying, unless directed otherwise by MTVE. Wherever it is necessary to deflect pipe from a straight line, the amount of deflection allowed shall not exceed pipe manufacturer’s recommendations for mechanical and “Tyton” joints.

For connection of “Tyton” joints, the joint make-up shall be done according to manufacturer’s recommendations, with special care used in cleaning gasket seats to prevent any dirt or sand from getting between the gasket and pipe. Lubricant to be used on the gasket shall be NSF approved, non-toxic, and free from contamination. When a pipe length is cut, the outer edge of the cut shall be beveled to the manufacturer’s specification to prevent damage to the gasket during joining. All cuttings shall be removed from the pipe prior to installation.

All fittings shall be cement-lined ductile iron and conform to the latest version of AWWA C104 or AWWA C153. Flange faces shall be machined to a flat surface with a serrated finish in accordance with AWWA C207.

Bolt kits, M.J. kits, and restraining kits shall be manufactured in the U.S.A.; **import is not allowed**. All bolted connections shall be tightened to the manufacturer’s specification using a **torque wrench**.

**Ductile Iron MJ Sleeves** shall be the only method of joining two plain end pipes together.

Valves, fittings, plugs and caps shall be set and jointed to pipe in the manner as required.

Fittings shall be adequately “blocked” with poured-in-place concrete, or concrete block at the discretion of MTVE, with a firm minimum bearing against an undisturbed earth wall. Timber blocking will not be permitted. Thrust blocks shall be poured as soon as possible after setting the fittings in place to allow the concrete to “set” before “swabbing” and applying the pressure test. The concrete thrust blocks must be in place before beginning the “swabbing” and pressure test. Anchor blocks shall be allowed to set sufficiently to develop the necessary bond strength between the reinforcing rods and the concrete anchor before beginning the pressure test.

All of the new piping, valves and blocking shall have been installed, “swabbed”, disinfected, and tested up to the point of tying into existing lines before the tie-in is made. All required tie-in parts shall be in full readiness as described in section 6 below prior to starting the tie-in.

#### HDPE Water Mains and Fittings.

High density polyethylene (HDPE) pipe and fittings shall be manufactured in accordance with the following standards

ASTM D3035 – ½ in through 24-in pipe

ASTM F714 – 3-in through 54-in pipe

AWWA C901 – 1/2 In. (130mm) through 3 In. (76 mm) pipe and tubing

AWWA C906 – 4 In. (100 mm) through 65 In (1,600 mm) pipe and fabricated fittings

ASTM D3261 – butt fusion fittings, saddles and flange adapters

ASTM F1055 – electrofusion couplings and saddles.

ASTM F2206 – fabricated fittings

#### FUSION TECHNICIAN REQUIREMENTS

Each Fusion Technician shall be separately qualified to make each type and size of fusion joint in accordance with ASTM F1290 and/or F2620. Fusion joint types are butt fusion, saddle fusion and electrofusion. Qualification to make one type or size of fusion joint shall not qualify a Fusion Technician to make a different type or size of fusion joint.

Pipe and fitting suppliers shall provide a two (2) year warranty covering defects in product material and workmanship. A successful pressure test or pressure leak test prior to the expiration of the warranty period shall not relieve the supplier of warranty responsibility for the full warranty term.

Fusion providers shall provide a two (2) year warranty from the date of installation acceptance covering defects in fusion joining workmanship that shall provide for remaking defective butt fusion, saddle fusion or electrofusion joints. A successful pressure test or pressure leak test prior to the expiration of the warranty period shall not relieve the installer of warranty responsibility for the full warranty term.

#### SUBMITTALS

The following information shall be submitted by pipe and fitting suppliers:

- a. Name of the pipe manufacturer and a list of the piping and quantities to be provided by manufacturer.
- b. Name(s) of fitting manufacturer(s) and lists of fittings and quantities to be provided by manufacturer.
- c. Pipe and fitting product data indicating conformance with this specification, applicable standards, and warranty provisions, including written documentation regarding any intended variance from this specification and applicable standards.
- d. At the time of shipment, the supplier shall provide certified documentation of pipe and fitting conformance with this specification and applicable pipe and fitting standards specified herein.

The following information shall be submitted by Fusion providers.

- a. Documentation that each Fusion Technician has met requirements for joining proficiency for each type of fusion joint performed by the Fusion Technician under this specification.
- b. Documentation of conformance with this specification and applicable standards, including written documentation regarding any intended variance from this specification and applicable standards. This will include fusion joint warranty information and recommended project specific fusion parameters, including criteria logged and recorded by data logger.
- c. The following AS-RECORDED DATA is required from the Contractor and/or Fusion Provider:

- 1) Fusion reports for each fusion joint performed on the project, including joints that were rejected. Submittals of the Fusion Technician's joint reports are required as requested by the Owner or Engineer. Specific requirements of the Fusion Technician's joint report shall include:
  - (a) Pipe or fitting size and DR or pressure class rating
  - (b) Fusion equipment size and identification
  - (c) Fusion Technician Identification
  - (d) Job Identification Number
  - (e) Fusion Number
  - (f) Fusion joining parameters
  - (g) Ambient Temperature

#### PIPE AND FITTINGS

PE4710 material (compound) shall conform to material requirements specified in AWWA C901 or AWWA C906 as applicable for the pipe or fitting. PE4710 material shall meet the requirements of ASTM D3350 and shall meet or exceed a cell classification of 445574 per ASTM D3350.

PE4710 material compound shall have a hydrostatic design stress (HDS) rating for water at 73°F (23°C) of not less than 1000 psi that shall be listed in PPI TR-4 in the name of the pipe manufacturer.

PE4710 material compound shall have a hydrostatic design basis (HDB) rating at 140°F (60°C) of not less than 1000 psi that shall be listed in PPI TR-4 in the name of the pipe manufacturer.

PE4710 pipe and fitting material compound in PE4710 pipe and fittings shall contain color and ultraviolet (UV) stabilizer meeting the requirements of Code C or E per ASTM D3350. Code C material shall contain 2 to 3 percent carbon black to provide indefinite protection against UV degradation when material from the pipe is tested in accordance with ASTM D1603 or ASTM D4218. Code E material used for coextruded OD color stripes or a coextruded ID color layer shall contain sufficient UV stabilizer to protect the pipe against UV degradation for at least 24 months of unprotected outdoor exposure. Coextruded color PE compound material shall be PE4710 pipe material compound, varying only by color and UV stabilizer.

*Qualification for potable water service.* PE4710 compounds shall be tested and certified as suitable for use with potable water in accordance with requirements that are no less restrictive than the applicable requirements in NSF/ANSI 61.

PE4710 pipe

Nominal straight lengths of 3 inch and larger pipe shall be 40 ft. or 50 ft.

Nominal coil lengths of 4-inch and smaller pipe shall be 500 ft. Longer or shorter coils such as 800 feet for 4-inch pipe, 1000 feet for 3-inch pipe, or 2000 feet for 2 inch or smaller pipe shall be acceptable.

Pipe shall be black. Coextruded OD blue stripes shall be an acceptable option.

Pipe shall be permanently marked using heated indent printing including:

- a. Nominal size and sizing system, e.g., IPS or DIPS
- b. DR or SDR
- c. Standard Designation, AWWA C901 or AWWA C906, material designation, and pressure rating or pressure class for water at 73°F.
  - 1) Marking the Standard Designation on the pipe shall serve as the manufacturer's certification that the pipe has been manufactured, sampled and tested and has been found to comply with the requirements of the standard.
  - 2) The AWWA C901 or C906 pipe pressure class for water at 73°F shall be "PE4710 PCXXX" where XXX = pressure class in psi.
- d. NSF-61 or NSFpw mark certifying suitability for potable water service
- e. Extrusion production-record code

#### PE4710 fittings

PE4710 butt fusion, saddle fusion, electrofusion and fabricated fittings shall be manufactured from PE4710 material (compound) in accordance with this specification.

PE4710 fittings shall comply with ASTM D3261 for molded butt fusion and saddle fusion fittings, flange adapters and MJ adapters, or shall comply with AWWA C906 for fabricated butt fusion fittings, or shall comply with ASTM F1055 for electrofusion fittings.

PE4710 fittings shall comply with the marking requirements of ASTM D3261 for molded butt and saddle fusion fittings, flange adapters and MJ adapters or shall comply with the marking requirements of AWWA C906 for fabricated butt fusion fittings, or shall comply with the marking requirements of ASTM F1055 for electrofusion fittings.

- a. Marking shall include the NSF-61 or NSFpw mark verifying suitability for potable water service.

PE4710 fittings shall have pressure class ratings not less than the pressure class rating of the pipe to which they are joined.

#### FUSION JOINTS

Unless otherwise specified, PE4710 pipe and fittings shall be assembled in the field with butt fusion, saddle fusion or electrofusion joints. ASTM F2620 and the pipe manufacturer's recommended procedure shall be observed for butt fusion and saddle fusion joints. ASTM F1290 and the electrofusion fitting manufacturer's recommended joining procedure shall be observed for electrofusion joints.

Field butt fusion, saddle fusion and electrofusion joints shall be made by Fusion Technicians that are qualified in accordance with this specification to make the specific fusion joint type.

Field fusion joints shall be recorded and documented in accordance with this specification.

#### MECHANICAL FITTINGS

Acceptable mechanical fittings for use with PE4710 pipe and fittings shall be mechanical fittings that are qualified by the mechanical fitting manufacturer for use with HDPE pipe and fittings.

Mechanical fittings for use with HDPE pipe shall provide restraint against longitudinal separation that is inherent to the design of the joint. Mechanical joints that do not provide restraint against pull-out or push-off are prohibited.

Mechanical connections to non-HDPE devices and appurtenances shall be by bolted flange adapter or MJ adapter. Flange adapter and MJ adapter connections shall be assembled, installed and tightened in accordance with flange adapter or MJ adapter manufacturer's instructions. Flange bolt tightening shall be in accordance with PPI TN-38.

#### GASKETED, PUSH-ON FITTINGS

Gasketed push-on fittings shall be fitted with external mechanical restraints that span across the joint and are assembled in accordance with restraint manufacturer's instructions.

- a. Thrust blocking does not provide acceptable restraint and is prohibited.
- b. Where plain-end PE4710 pipe is assembled with push-on fittings, the PE4710 pipe end shall be fitted with electrofusion restraints so that external mechanical restraint may be secured to the PE4710 pipe.

Where PE4710 pipe is connected to gasketed mechanical joint fittings or appurtenances, the connection shall be made by butt fusing a PE4710 MJ Adapter to the PE4710 pipe and connecting the PE4710 MJ Adapter to the mechanical joint fitting or appurtenance.

#### SLEEVE-TYPE COUPLINGS

Sleeve-type mechanical couplings shall be manufactured for use with HDPE pipe, and shall be restrained as indicated in these specifications. Unrestrained sleeve-type couplings are prohibited.

#### EXPANSION AND FLEXIBLE COUPLINGS

Expansion-type mechanical couplings are prohibited.

#### CONNECTION HARDWARE

Bolts and nuts for buried service shall be made of non-corrosive, high-strength, low-alloy steel having the characteristics specified in ANSI/AWWA C111/A21.11, regardless of any other protective coating.



## DELIVERY AND OFF-LOADING

All piping shall be bundled or packaged for transportation to the site.

Before off-loading, pipe shall be inspected for damage. Any pipe damaged in shipment shall be assessed and either accepted or rejected as directed by MTVE or Engineer, and the pipe supplier shall be notified of rejected pipe within 7 days of delivery at the site. Rejected pipe shall be quarantined for disposition. Each pipe shipment shall be checked for quantity and proper pipe size, color and type.

Pipe shall be off-loaded and handled in accordance with the pipe manufacturer's instructions and AWWA M55.

## HANDLING AND STORAGE

Pipe lengths should be placed and stored on level ground. Pipe should be stored at the job site in the unit packaging provided by the manufacturer. The interior of the pipe, as well as all end surfaces, should be kept free from dirt and foreign matter.

Pipe shall be handled and supported with the use of woven fiber pipe slings or approved equal. Care shall be exercised when handling the pipe to not cut, gouge, scratch or otherwise abrade the piping in any way. Use of hooks, chains, wire rope or any other handling device which creates the opportunity to damage the surface of the pipe is strictly prohibited.

Covering or shading of PE4710 pipe and fittings against exposure to ultraviolet light from sunlight is not required.

## FUSION PROCESS

Butt and saddle fusion of PE4710 pipe and fittings shall be in accordance with ASTM F2620 and the manufacturer's recommended joining procedure.

Electrofusion of PE4710 pipe and fittings shall be performed in accordance with ASTM F1290 and the electrofusion fitting manufacturer's recommended procedure.

PE4710 pipe and fittings shall be fused by qualified fusion technicians, as documented by the fusion provider. Training records for qualified fusion technicians shall be available to MTVE upon request.

As each fusion joint is constructed, pressure, time and temperature parameters shall be recorded and logged by an electronic monitoring device (data logger) affixed to the fusion machine. Joint data shall be submitted as part of the As-Recorded information, in accordance with this specification.

Butt fusion machines shall incorporate the following properties, including the following elements:

- a. HEAT PLATE – Heat plates and the non-stick coatings on heating surfaces shall be in good condition without heating surface gouges or scratches. The non-stick coating shall be intact, clean and free of any contamination. Heater controls and temperature indicators shall function properly, and electrical cords and connections shall be in good condition.

The heat plate shall maintain a uniform and consistent temperature on all areas of the heating surfaces on both sides of the heat plate.

- b. CARRIAGE – Carriage shall travel smoothly with no binding at less than 50 psi for hydraulic fusion machines. Clamps shall be in good condition with proper inserts for the pipe size being fused.
- c. GENERAL MACHINE – Overview of machine body shall yield no obvious defects, missing parts, or potential safety issues during fusion.
- d. DATA LOGGER – The current version of the pipe supplier’s recommended and compatible software shall be used. Protective case shall be utilized for the hand held wireless portion of the unit. Data logger operations and maintenance manual shall be with the unit at all times. If fusing for extended periods of time, an independent 120V power source shall be available to extend battery life.

Other equipment specifically required for fusion processes shall include the following:

- e. Pipe rollers shall be used to support pipe to either side of the butt fusion machine and provide for vertical and lateral pipe alignment straight through the butt fusion machine.
- f. A protective enclosure that provides for full machine motion of the clamps, heat plate, fusion assembly and carriage shall be provided for fusion in inclement and/or windy weather. Pipe ends shall be covered or blocked where open pipe ends could allow prevailing winds to blow through the pipe.
- g. Fusion machine operations and maintenance manual shall be kept with the fusion machine at all times.

#### JOINT RECORDING

Each fusion joint shall be recorded and logged by an electronic monitoring device (data logger) connected to the fusion machine that shall register and/or record the parameters required by the manufacturer and these specifications. Data not logged by the data logger shall be logged manually and be included in the Fusion Technician’s joint report.

Fusion reports for each fusion joint performed on the project, including joints that were rejected. Submittals of the Fusion Technician’s joint reports are required as requested by MTVE and the Engineer. Specific requirements of the Fusion Technician’s joint report shall include:

- (a) Pipe or fitting size and DR or pressure class rating
- (b) Fusion equipment size and identification
- (c) Fusion Technician Identification
- (d) Job Identification Number
- (e) Fusion Number
- (f) Fusion joining parameters

(g) Ambient Temperature

INSTALLATION

The PE4710 pipe and fittings shall be installed such that PE4710 pipe curvature is not less than the minimum bending radius recommended by the pipe manufacturer.

Direct burial installation of PE4710 pressure pipe shall be in accordance with ASTM D2774 and the pipe manufacturer's recommendations.

Installation of PE4710 pipe by horizontal directional drilling shall be in accordance with ASTM F1962 or PPI TR-46 and the pipe manufacturer's recommendations.

Installation of PE4710 pipe by sliplining or insertion within a casing or host pipe shall be in accordance with ASTM F585 and the pipe manufacturer's recommendations.

Tracer Wire – All PE4710 piping shall be installed with a continuous, insulated TW, THW, THWN, or HMWPE insulated copper, 10 gauge or thicker wire for pipeline location purposes by means of an electronic line tracer.

- a. The wires shall be installed along the entire length of the pipe.
- b. Sections of wire shall be spliced together using approved splice caps and waterproof seals. Twisting the wires together is not acceptable.

MAKING CONNECTIONS TO NON-PE4710 PIPING SYSTEMS

Approximate locations for non-PE4710 piping systems are shown on the drawings or detailed in the specifications. Prior to making connections into existing piping systems, the Contractor shall:

- a. Verify the actual field location, size, piping material and service of non-PE4710 piping systems.
- b. Obtain all required non-PE4710 piping manufacturer(s) approved fittings (i.e., saddles, sleeve type couplings, flanges, tees, etc., as shown).
- c. Have on hand pipe stoppers, blind flanges or other devices to seal a valve or appurtenance that fails to seal properly. When applied to pressure rated valves or appurtenances, all such devices shall be pressure rated equal to or greater than the pressure rating of the valve or appurtenance to which they are attached.

Where PE4710 pipe connects in-line to unrestrained gasketed push-on piping, the end of the PE4710 pipe shall be anchored in-line within 10 feet of the connection to restrict longitudinal movement of the PE4710 pipe.

- a. The PE4710 pipe shall be fitted with a PE4710 wall anchor or electrofusion flex restraints.
- b. The PE4710 wall anchor or electrofusion flex restraints shall be encased in reinforced concrete that is sufficient to withstand Poisson effect longitudinal loads in accordance with AWWA M55 In-Line Anchoring.

Unless otherwise approved by MTVE, new piping systems shall be completely assembled and successfully tested prior to making connections to non-PE4710 piping systems.

## PIPE SYSTEM CONNECTIONS

Pipe connections shall be installed per applicable standards and regulations, as well as per the connection manufacturer's recommendations and as indicated on the drawings. Pipe connections to structures shall be installed per applicable standards and regulations, as well as per the connection manufacturer's recommendations.

## TRACER WIRE TESTING

Upon completion of installation by direct burial, sliplining, directional boring or pipe bursting, the Contractor shall demonstrate that the tracer wire is continuous and unbroken through the entire run of the pipe.

- a. Demonstration shall include full signal conductivity (including splices) when energizing for the entire run in the presence of MTVE inspector.
- b. If the wire is broken, the Contractor shall repair or replace it. Pipeline installation will not be accepted until the tracer wire passes a continuity test.

## TAPPING

Tapping shall be performed using standard saddle fusion fittings, electrofusion saddle fittings, or mechanical tapping saddles or sleeves designed for use on HDPE piping. Tapping by threading directly into the PE4710 pipe wall is prohibited.

Branching connections requiring a larger diameter shall be made with saddle fusion branch saddle fittings or mechanical branch connection fittings as specified and indicated on the drawings.

Equipment used for tapping shall be made specifically for tapping HDPE pipe:

- a. Tapping bits shall be slotted "shell" style cutters, specifically made for HDPE pipe. 'Hole saws' made for cutting wood, steel, ductile iron, or other materials are strictly prohibited.
- b. Manually operated or power operated drilling machines may be used.

Taps may be performed while the pipeline is filled with water and under pressure, or when the pipeline is not filled with water and not under pressure.

## TESTING

Testing shall comply with most current AWWA and DOH standards.

Segments of the pipe may be tested separately in accordance with most current AWWA and DOH standards.

## HYDROSTATIC LEAKAGE TESTING

- a. Hydrostatic leakage testing shall comply with ASTM F2164. Joint leakage and any defective materials and/or workmanship shall be repaired or replaced by the Contractor at no additional cost to the Owner.
- b. Pneumatic (compressed air) leakage testing of PE4710 pressure piping is prohibited.

B. Valves.

All valves larger than twelve (12) inches shall be butterfly valves. All valves twelve (12) inches and smaller shall be gate valves.

(1) Gate Valves

Gate valves shall be Resilient Wedge in accordance with AWWA C509, or C515. The valve shall open to the left (counter clockwise looking at the operating nut) and be equipped with a two (2) inch square operating nut. The valves shall be set with stems vertical. The gate valves shall be manufactured by **Mueller, Clow, Kennedy, U.S. Pipe, or M&H.**

(2) Butterfly Valves

Butterfly valves shall be of the tight-closing rubber seat type with rubber seat either bonded to the body or mechanically retained in the body with no fasteners or retaining hardware in the flowstream. The valves may have rubber seats mechanically affixed to the valve vane. Where threaded fasteners are used, the fasteners shall be retained with a locking wire or equivalent provision to prevent loosening. Rubber seats attached to the valve vane shall be equipped with stainless steel seat ring integral with the body, and the body internal surfaces shall be coated with a two-coat epoxy system to prevent tuberculation buildup which might damage the disc-mounted rubber seat.

No metal-to-metal sealing surfaces shall be permitted. The valves shall be bubble-tight at rated pressures with flow in either direction, and shall be satisfactory for applications involving valve operations after long periods of inactivity. Valve discs shall rotate ninety (90) degrees from the full open position to the right shut position. The valves shall meet the full requirements of AWWA Specification C-504, Class 150B. The valve shall be manufactured by **Mueller, Clow, Kennedy, U.S. Pipe, or M&H.**

(3) Tapping Sleeves and Tapping Valves

The tapping sleeves shall be **Mueller H-615 Mechanical Joint**, furnished complete with joint accessories. Tapping sleeves shall be constructed in two sections for ease of installation and shall be assembled around the main without interrupting service.

Tapping valves shall be **Mueller T-2360** provided with a standard mechanical joint outlet for use with ductile iron pipe and shall have oversized seat rings to permit entry of the tapping machine cutters. In all other respects, the tapping valves shall conform to the gate valves herein specified with regards to operation and materials.

(4) All Valves

All valves with operating nuts located more than 3'-0" below finished grade shall be equipped with extension stems to bring the operating nut to within 3'-0" of the finished grade.

At the top of the extension stem, there shall be a two (2) inch standard operating nut, complete with a centering flange that closely fits the five (5) inch soil pipe encasement of the extension stem. The valve box shall be set in a telescoping fashion around the five (5) inch soil pipe cut to the correct length so no valve box parts are "bottomed out".

All valves shall have an **Adapter Inc Valve Box Adapter II** installed prior to placing the valve box lower section.

Each valve shall be provided with a "940" style adjustable two-piece cast iron valve box of five (5) inches minimum inside diameter. The top section shall be eighteen (18) inches long and have a three (3) inch tall lid. The lower section shall be twenty four (24) inches long and have an eight (8) inch opening on the bottom to fit the **Adapter Inc Valve Box Adapter II**.

Concrete marker posts shall have a three (3) inch minimum square section and a minimum length of thirty-six (36) inches, with beveled edges, and contain at least one (1) three-eighths (3/8) inch diameter bar of reinforcing steel. Markers shall be placed at the edge of the right-of-way opposite the valve, and set so as to leave twelve (12) inches of the post exposed above grade. The exposed portion of the marker posts shall be painted with two (2) coats of Preservative Brand International Blue enamel paint. Distance to referenced valve shall be to the nearest 0.5 foot, and shall be clearly stenciled in black numerals two (2) inches in height.

C. Fire Hydrants.

Standard five and one-quarter (5-1/4) inch MVO fire hydrants are required. Spacing shall conform to East Pierce Fire and Rescue and City of Edgewood regulations.

Pipes connecting hydrants to mains must be at least six (6) inches in diameter and not longer than three (3) feet.

The contractor shall place a sufficient amount of 1-1/4" washed drain rock around the hydrant base to ensure proper drainage of the hydrant barrel. Cover the drain rock with filter fabric prior to final backfill.

All fire hydrants shall be approved by the National Board of Fire Underwriters and conform to AWWA Specification C-502, break-away type, with holding spool, in which the valve will remain closed if the barrel is broken. The hydrant barrel shall have a diameter of not less than seven (7) inches, and the valve diameter shall be not less than five and one-quarter (5-1/4) inches. Each hydrant shall be equipped with two (2) two and

one-half (2-1/2) inch hose ports (National Standard Thread) with caps and chains, and one (1) four and one-half (4-1/2) inch pumper connection (National Standard Thread), with 5" Storz fitting and cap and cable. Each hydrant shall be equipped with a suitable positive acting drain valve and one and one-quarter (1-1/4) inch pentagonal operating nut (counter-clockwise opening). The fire hydrants shall be **Mueller Centurion**, or **Clow Medallion**.

The holding spools between the gate valve and fire hydrant shall be made from six (6) inch Class 52 ductile cast iron pipe. The hydrant and gate valve shall be anchored in place using M.J. Mega Lug kits (domestic manufacture only). Holding spools shall not be longer than three (3) feet.

Two hydrant guard posts (if required) shall be installed and painted for each hydrant assembly.

The hydrants and guard posts shall be painted with two (2) coats of Safety Yellow enamel paint.

An asphalt or concrete thrust pad, 7' x 7' x 6" thick, shall be centered on the hydrant. The top of the thrust pad shall be the same elevation as the Bury Line on the hydrant barrel. The pad shall extend to the roadway, sidewalk or as directed by the inspector and be 7' wide.

Between the time that the hydrant is installed and the completed facility is placed in operation, the hydrant shall at all times be wrapped or covered in a suitable manner to clearly indicate that the hydrant is not in service.

#### D. Blow-Offs and Air Relief Assemblies.

Dead-end lines are not permitted except where MTVE determines that it would be impractical to extend the line at a future date. Water mains on platted cul-de-sacs shall extend as determined by MTVE to the neighboring property(s) for a future connection. A two (2) inch **Kupferle** Model 78 blow-off assembly or **Automatic Flushing** blow-off must be provided per the detail at all water main ends.

One inch (1) or two (2) inch **APCO**, **Valmatic**, or **Crispin** air and vacuum release valves shall be installed at principal high points in the system per the detail.

The installation of these items shall include connection piping, gate valve, valve box, valve marker and all accessories. All fittings and parts shall be low lead and comply with NSF/ANSI 61, Annex G and NSF/ANSI 372 or the most current version in place at the time of installation.

E. Sample Stations

A minimum of one (1) **Kupferle** Model 88 Sample Station shall be installed for every Development, Water Main Extension or Fire Hydrant installation per the detail. Additionally, sample stations shall be placed every 500' or as MTVE requires. All fittings and parts shall be low lead and comply with NSF/ANSI 61, Annex G and NSF/ANSI 372 or the most current version in place at the time of installation.

F. Water Services

Water service lines shall be 1- inch or 2- inch **CTS Rehau Municipex**, one service per tap. All fittings shall be 110 CTS compression as manufactured by the **Mueller** Company. **Mueller** inserts shall be used. All other water service material shall be brass. All installations shall conform to the detail. All fittings and parts shall be low lead and comply with NSF/ANSI 61, Annex G and NSF/ANSI 372 or the most current version in place at the time of installation.

G. Premises Isolation and Fire Systems

The Premises Isolation Assembly for residential connections shall be a **Wilkins 950XLTUSH** Double Check Valve Assembly (DCVA) unless a hazard is present that is listed on Table 9 of WAC 246-290-490. If a hazard is present then the required Premises Isolation Assembly shall be a **Wilkins 975XL** Reduced Pressure Backflow Assembly (RPBA). All fittings and parts shall be low lead and comply with NSF/ANSI 61, Annex G and NSF/ANSI 372 or the most current version in place at the time of installation.

The Premises Isolation Assembly for non-residential connections (e.g. commercial, industrial, municipal, schools, care facilities, etc) shall be a **Wilkins 975XL** RPBA. The RPBA shall be installed in a Hot Box and be heated to prevent freezing. The property owner shall be responsible for supplying power to the Hot Box and for maintaining the heating equipment, and for damage to the assembly and box.

The Backflow Protection Assembly for a Fire System shall be an RPDA. The bypass meter shall be a Sensus SR11 TPRL reading in Cubic Feet and have a 520 RA MXU U.S. Alt Frequency installed. The RPDA shall be installed in a Hot Box and be heated to prevent freezing. The property owner shall be responsible for supplying power to the Hot Box and for maintaining the heating equipment, and for damage to the assembly and box.

Premises Isolation and Fire System Backflow Assemblies (DCVA, RPBA, and RPDA) shall be installed one (1) foot the customer side of the water meter and within the Right of Way (ROW) or Easement or as detailed on the plans. If space constraints make placement on the ROW impossible, then the assembly may be placed on private property as long as an easement is granted in favor of MTVE prior to installation. The current and all future owners of the property shall allow unlimited access. If access is denied, then water service to the property shall be terminated. No taps are allowed on the service line



between the water meter and the Premises Isolation Assembly. Taps are allowed on the service line four (4) feet beyond the Premises Isolation Assembly.

#### H. Control Valves and Vaults

The following specification is the minimum standard for Control Valves and Vaults. Refer to the approved plans for any additionally required items.

The valves shall be hydraulically operated globe or angle pattern and manufactured by **Cla-Val** or **Singer Valve**. The inner valve assembly shall be top and bottom guided by means of bearing bushings. The inner valve (diaphragm) assembly shall be the only moving part and shall be securely mounted on a 316 stainless steel stem. The stainless steel stem shall be provided with wrench flats on all valves up to 16-inch for ease of assembly and maintenance. All pressure containing components shall be constructed of ASTM A536-65/45/12 ductile iron. The flanges shall be ANSI Class 150 or as noted on the plans.

The valves shall have a blue protective fusion bonded epoxy coating internally and externally. The protective fusion bonded epoxy coating shall conform to the ANSI/AWWA C116/A21.16 (or most current version) specification.

All valve bonnets shall be accurately located to bodies utilizing locating pins or locating lips. Locating lips are allowed as long as provisions are made to prevent internal and external rust.

Valves 3" and larger shall have a 316 stainless steel seat, bolted or threaded in place. If special tools are required to remove and replace the seat, the Developer shall supply these tools for each valve size to MTVE at no additional cost.

All external fasteners shall be 18/8 stainless steel with 18/8 washers. All sensor and pilot control lines shall be stainless steel braided Teflon with a working pressure of 2500 P.S.I. with stainless steel crimp fittings.

Developer shall provide MTVE a copy of the warranty that specifies the following: the valves shall be covered by a minimum three year warranty against defects in materials and workmanship provided the valve is installed and used in accordance with all applicable instructions; electrical components shall have a one year warranty; the stainless steel seat ring shall be covered by a lifetime replacement warranty.

All vaults shall be a maximum of 48" from finished floor to final grade and be supplied with a 4" drain. The drain shall be plumbed to the nearest storm system. Double traffic-rated aluminum doors shall be included that open to at least 90 degrees from flat and include provisions for a pad lock. All ladders shall comply with the latest L&I and OSHA requirements and include a pull-up hand rail that extends at least 42" above the vault top. Vault walls and ceiling shall be painted white. Vaults shall be located in private easements only.

All vault piping 4-inch and larger shall be flanged Class 52 Ductile Iron with full face gaskets. Piping 2-inch and smaller shall be schedule 80 brass and include unions for easy removal. Ductile Iron piping and fittings shall have two coats of Blue two part **Tnemec** Epoxy applied. Epoxy shall be applied per manufacturer's guidelines.

P.R.V. installations shall include stainless steel 4-inch liquid filled gauges with 3/4" **Mueller** B-20045N shut-offs on the upstream and downstream piping. Also include a minimum 1-inch Inlet Air Release Valve and 1-inch Outlet Combination Valve with **Mueller** B-20045N isolation valves. On main extensions that will need two P.R.V. stations each station shall use a single control valve that has low flow stability (eliminating the need for a smaller, low flow, bypass control valve). Low flow rate shall be 0.5 GPM for 6-inch valves, 1.0 GPM for 8-inch valves, and 5 GPM for 10-inch valves. If an existing P.R.V. station will supply part of the new main extension area it shall be retrofitted to the low rates above and the smaller control valve removed.

All fittings and parts shall be low lead and comply with NSF/ANSI 61, Annex G and NSF/ANSI 372 or the most current version in place at the time of installation.

The Developer shall ensure, at no cost to MTVE, that a factory representative is on-site for start-up service and necessary adjustments.

## **5. WATER MAIN DISINFECTING, TESTING, AND SAMPLING**

All pipelines shall be "swabbed", disinfected, pressure tested and sampled prior to being placed in service.

The Developer shall provide acceptable sample sites, as determined by MTVE, to ensure representative samples are taken throughout the new line. At a minimum the sample sites shall be located every 500 feet and at all pipe ends. Two (2) or more water sample failures shall require sample sited to be located every 200 feet or as directed by MTVE.

The pipeline shall be bedded and backfilled sufficiently to prevent movement of the pipe under pressure. All thrust blocks shall be in place and time allowed for the concrete to cure before "swabbing" and testing. Where permanent blocking is not required, the Developer shall furnish and install temporary blocking.

As soon as the pipeline is adequately secured against movement under pressure, it may be filled by an MTVE employee with water. **Developer shall not operate any system valves.** Satisfactory performance of air valves must be checked while the line is filling.

The Developer shall then clean and flush the pipeline using the 2 lb. per cu/ft foam "swab" complete with rear polyurethane drive seal that was inserted into the first pipe section. Cleaning and flushing shall be accomplished by propelling the "swab" down the pipeline to the exit point with potable water. Flushing shall continue until the water is completely clear. If the water is muddy or has debris in it the Developer may be required

to run additional “swabs” through the entire pipeline. If the cleaning and exit point is through a Fire Hydrant (8” pipeline or smaller) the Developer shall remove the hydrant internal valve assembly to allow passage of the “swab”.

Chlorine for disinfecting shall then be applied, by the Developer, by injecting a 12.5% hypochlorite solution through a corporation stop valve or other injection point at beginning of the main while it is being filled to insure a concentration in the pipe of fifty (50) mg/L. Filling of pipeline shall be at a rate of 100 GPM. **Developer shall not operate any system valves.**

After the desired chlorine concentration has been obtained through the entire section of line, the water in the line shall be left standing for at least forty-eight (48) hours or as directed by the MTVE inspector.

The water main shall be pressure tested per WSDOT/APWA Section 7.09.3(23). Test pressure shall be 150 psi above static pressure but not less than 225 psi and shall be held for one (1) hour. **Prior to testing, the developer must ensure that the curb stops to all sample stations, air releases, and other curb stops as directed by MTVE are closed.** All pumps, gauges, plugs, saddles, corporation stops, miscellaneous hose and piping, and measuring equipment necessary for performing the pressure test shall be furnished, disinfected, installed, and operated by the Developer. Feed water for the test pump shall be from a disinfected barrel or other container so that the actual amount of “makeup” water can be measured periodically during the test period. Feed water shall contain a chlorine dose of fifty (50) mg/L. All tests shall be made with the hydrant auxiliary gate valves open and pressure against the hydrant foot valve. Hydrostatic tests shall be performed on every complete section of water main between two valves, and each valve shall withstand the same test pressure as the pipe with no pressure active in the section of pipe beyond the closed valve.

Defective materials or workmanship, discovered as a result of the tests, shall be replaced by the Developer at the Developer’s expense. Whenever it is necessary to replace defective material or correct the workmanship, the “swabbing”, disinfection, and pressure test shall be re-run at the developer’s expense until a satisfactory test is obtained.

Following the successful pressure test, the line shall be thoroughly flushed and allowed to stand for twenty four (24) hours before the first set of water samples are collected. Twenty four (24) hours later a second set of water samples shall be collected. Flushing is not allowed during these periods.

At the Developers expense, MTVE personal shall collect water samples. Samples shall only be collected Monday through Thursday (excluding Federal holidays and up to two days prior to Federal holidays) so the Developer must plan flushing accordingly. The Developer shall be responsible for supplying all flushing equipment and flushing the new water mains prior to water samples being taken. **Developer shall not operate any system valves.** Disposal of the water shall be the Developer’s responsibility and shall conform to any special requirements and permits mandated by the Department of

Ecology, Department of Health, The City of Edgewood and/or Pierce County Public Works.

Samples must pass Coliform, E coli, fecal coli (Bact-T) tests using the Membrane Filter (MF) test technique and have an HPC count below 20. If the first test fails, the line shall be injected again with chlorine and retested as above. If the line fails a second time the contractor may be directed again to “swab” the line, inject chlorine and test as above.

If, after a second round of testing either the MF or HPC fail, subsequent rounds of testing shall include an additional set of MF and HPC samples 7 days after a passing 48 hour test. Water used after the first test for testing and flushing shall be billed to the Developer at the current rate shown on the MTVE Fee Schedule. The line must not be placed in service until a satisfactory bacteriological report has been received.

If, third, fourth, fifth or sixth sets of testing are required the samples shall be taken at 24 hours, 48 hours, and 7 days intervals. The sample locations shall be reduced to 200 foot intervals.

If, at the end of the sixth round of testing, the pipeline fails the Bact-T and/or HPC requirements, further testing of the pipeline will be terminated and the contractor shall remove the pipeline and all appurtenances from the ground and re-lay a new pipeline using new pipe and appurtenances. All testing shall start over.

Chlorine injection port shall be abandoned after satisfactory water quality results.

## **6. FINAL CONNECTIONS TO EXISTING WATER MAINS**

All pipe, fittings, and other material that will be used for tie-in's shall be “swabbed” and disinfected. Immerse the parts in water containing 50 mg/l chlorine and let stand for forty-eight (48) hours. A chlorine residual of not less than 25 mg/l shall remain in the water after standing 48 hours or the procedure shall be repeated.

Any pipe requiring further cutting, including the existing water main, shall have all cuttings removed and be “swabbed” with chlorine prior to assembly.

## **7. ACCESS AND CLEARANCES AROUND WATER APPURTENANCES**

All new facilities and related appurtenances (Hydrants, Blow-offs, Meters, Valves, Sample Stations, PRV Stations, etc.) shall be accessible from the roadway and not blocked by fencing or any other barrier. Utility pedestals (phone, power, communication, etc.) shall not block the road side of the facility and shall be located a minimum of 36” away from the sides and rear of the facility. All landscaping shall be designed and placed so the mature plant drip line remains at least 24” from the sides and rear of all facilities. No plantings are allowed between the facility and the roadway.

SECTION IV  
DEVELOPMENT DETAILS

SECTION IV DEVELOPMENT DETAILS

TABLE OF CONTENTS

<u>PAGE</u>	<u>DESCRIPTION</u>
IV-1	WATER MAIN TRENCH SECTION
IV-2	VERTICAL ANCHOR BLOCK
IV-3	THRUST LOADS
IV-4	THRUST BLOCKS PLAN AND ELEVATION
IV-5	VALVE BOX ADJUSTMENT
IV-6	VALVE OPERATING NUT EXTENSION
IV-7	FIRE HYDRANT ASSEMBLY
IV-8	ASPHALT PAVEMENT REPAIR WITHOUT OVERLAY
IV-9	2" BLOW OFF
IV-10	1" AIR & VACUUM RELESE ASSEMBLY
IV-11	2" AIR & VACUUM RELEASE ASSEMBLY
IV-12	WATER SAMPLING STATION (Page 1 of 2)
IV-13	WATER SAMPLING STATION (Page 2 of 2)
IV-14	¾", 1" SINGLE METER SERVICE
IV-16	1-1/2" & 2" SINGLE METER SERVICE WITH BYPASS
IV-17	1" PREMISES ISOLATION D.C.V.A
IV-18	1" PREMISES ISOLATION R.P.B.A.
IV-19	UTILITY AND SEWER CROSSING (Page 1 of 2)
IV-20	UTILITY AND SEWER CROSSING (Page 2 of 2)

FINISHED GRADE  
OR SUBGRADE

COMPACTED BACKFILL CONSISTING  
OF 5/8" CRUSHED GRAVEL  
OR C.D.F. AS DIRECTED

SPECIAL PRECAUTIONS TO  
PROTECT PIPE TO THIS LEVEL

HAND-PLACED, COMPACTED  
5/8" CRUSHED BACKFILL

WATER MAIN

5/8" CRUSHED  
GRAVEL AS NEEDED

UNDISTURBED  
EARTH

TRENCH WIDTH

4'-0" MAXIMUM

12"

PIPE O.D.

6" PIPE	=	1'-6"
8" PIPE	=	2'-0"
10" PIPE	=	2'-6"
12" PIPE	=	2'-6"
16" PIPE	=	3'-0"

\* TRENCH DAMS TO BE INSTALLED  
AS DESIGNED BY ENGINEER.

MT. VIEW - EDGEWOOD WATER COMPANY  
STANDARD DETAIL IV -1

WATER MAIN  
TRENCH SECTION

2010\2010928-MVE-WSP-STANDARDS\IV-2VERTBLK 1=1 3-23-11 RLD

**TYPE "A" BLOCKING**  
FOR 11 1/4°-22 1/2° VERTICAL BENDS

PIPE SIZE NOMINAL DIAMETER - INCHES	TEST PRESSURE PSI	VB VERTICAL BEND DEGREES	NO. OF CU. FT. OF CONC. BLOCKING	S SIDE OF CUBE LIN. FT.	D DIAM. OF SHACKLE RODS (2) INCHES	L DEPTH OF RODS IN CONCRETE LIN. FT.
4"	300	11-1/4	8	2	5/8"	1.5
		22-1/2	11	2.2		2.0
		30	17	2.6		
6"	300	11-1/4	11	2.2	5/8"	2.0
		22-1/2	25	2.9		
		30	41	3.5		
8"	300	11-1/4	16	2.5	5/8"	2.0
		22-1/2	47	3.6		
		30	70	4.1		
12"	250	11-1/4	32	3.2	5/8"	2.0
		22-1/2	88	4.5		
		30	132	5.1		
16"	225	11-1/4	70	4.1	7/8"	3.0
		22-1/2	184	5.7	1-1/8"	4.0
		30	275	6.5	1-1/4"	
20"	200	11-1/4	91	4.5	7/8"	3.0
		22-1/2	225	6.1	1-1/4"	4.0
		30	330	6.9	1-3/8"	4.5
24"	200	11-1/4	128	5.0	1"	3.5
		22-1/2	320	6.8	1-3/8"	4.5
		30	480	7.9	1-7/8"	5.5

**TYPE "B" BLOCKING**  
FOR - 45° VERTICAL BENDS

		VB		S	D	L
4"	300	45	30	3.1	5/8"	2.0
6"			68	4.1		
8"			123	5.0		
12"	250		232	6.1	3/4"	2.5
16"	225		478	7.8	1-1/8"	4.0
20"	200		560	8.2	1-1/4"	
24"			820	9.4	1-3/8"	4.5

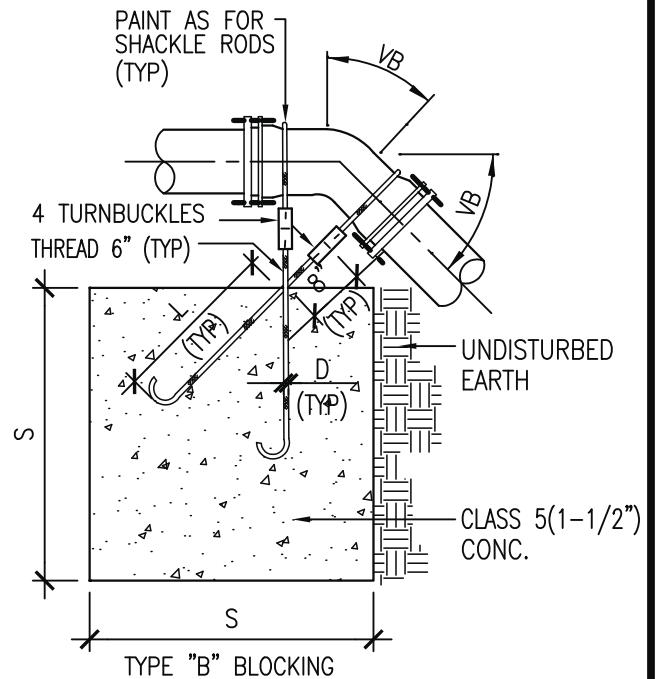
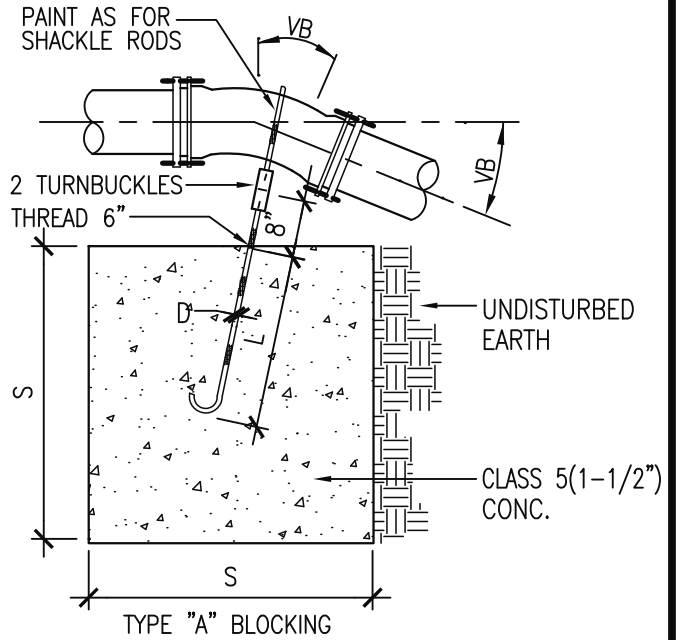

**MT. VIEW - EDGEWOOD WATER COMPANY  
STANDARD DETAIL IV -2**

**VERTICAL  
ANCHOR BLOCKING**





THRUST LOADS					
THRUST AT FITTINGS IN POUNDS AT 200 POUNDS PER SQUARE INCH OF WATER					
PIPE DIAMETER	90° BEND	45° BEND	22-1/2° BEND	11-1/4° BEND	DEAD END OR TEE
4"	3,600	2,000	1,000	500	2,600
6"	8,000	4,400	2,300	1,200	5,700
8"	14,300	7,700	4,000	2,000	10,100
10"	22,300	12,100	6,200	3,100	15,800
12"	32,000	17,400	8,900	4,500	22,700
14"	43,600	23,600	12,100	6,100	30,800
16"	57,000	30,800	15,700	7,900	40,300

NOTES:

- ① BLOCKING SHALL BE COMMERCIAL CONCRETE POURED IN PLACE AGAINST UNDISTURBED EARTH. FITTING SHALL BE ISOLATED FROM CONCRETE THRUST BLOCK WITH PLASTIC OR SIMILAR MATERIAL.
- ② TO DETERMINE THE BEARING AREA OF THE THRUST BLOCK IN SQUARE FEET (SF):  
 EXAMPLE: 12" - 90° BEND IN SAND AND GRAVEL  
 $32,000 \text{ LBS} / 3000 \text{ LB} / \text{S.F.} = 10.7 \text{ S.F. OF AREA}$
- ③ AREAS MUST BE ADJUSTED FOR OTHER PIPE SIZE, PRESSURES AND SOIL CONDITIONS.
- ④ BLOCKING SHALL BE ADEQUATE TO WITHSTAND FULL TEST PRESSURE AS WELL AS TO CONTINUOUSLY WITHSTAND OPERATING PRESSURE UNDER ALL CONDITIONS OF SERVICE.

SAFE SOIL BEARING LOADS

FOR HORIZONTAL THRUSTS WHEN THE DEPTH OF COVER OVER THE PIPE EXCEEDS TWO (2) FEET.

SOIL TYPE	POUNDS PER SQUARE INCH
MUCK, PEAT, ETC.	0
SOFT CLAY	1,000
SAND	2,000
SAND AND GRAVEL	3,000
SAND AND GRAVEL CEMENTED WITH CLAY	4,000
HARD SHALE	10,000

**MT. VIEW - EDGEWOOD WATER COMPANY  
STANDARD DETAIL IV-3**

**THRUST LOADS**



2010\2010928-MVE-WSP-STANDARDS\IV-4THRSTBLK 1=1 3-23-11 RLD

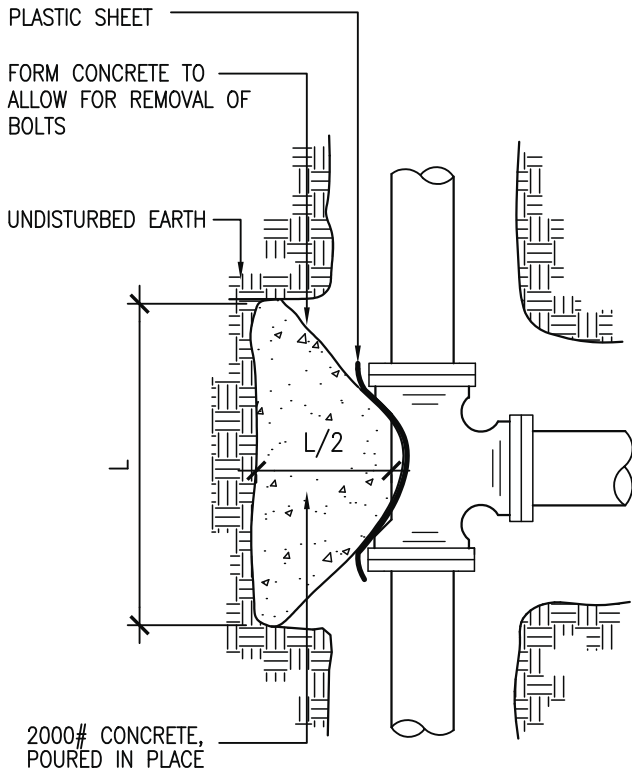

**PLAN**

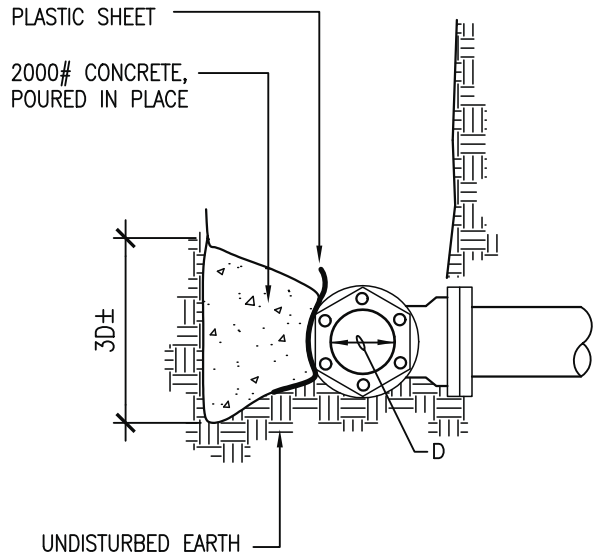

**ELEVATION**

NOTES:

1. BEARING AREA TABLE BASED ON 250 PSI PRESSURE AND 2000 PSF SOIL BEARING. IF PRESSURE IS GREATER OR SOIL BEARING IS LESS, THE THRUST BLOCK SIZE SHALL BE INCREASED.
2. THIS TABLE REPRESENTS THE "MINIMUM" CONSTRUCTION STANDARDS. THE DEVELOPER'S ENGINEER SHALL BE RESPONSIBLE FOR DETERMINING THE APPROPRIATE SIZE OF ALL THRUST BLOCKS BASED ON EXISTING AND LOCAL CONDITIONS.

**MT. VIEW - EDGEWOOD WATER COMPANY  
STANDARD DETAIL IV-4**

**THRUST BLOCKS  
PLAN AND ELEVATION**



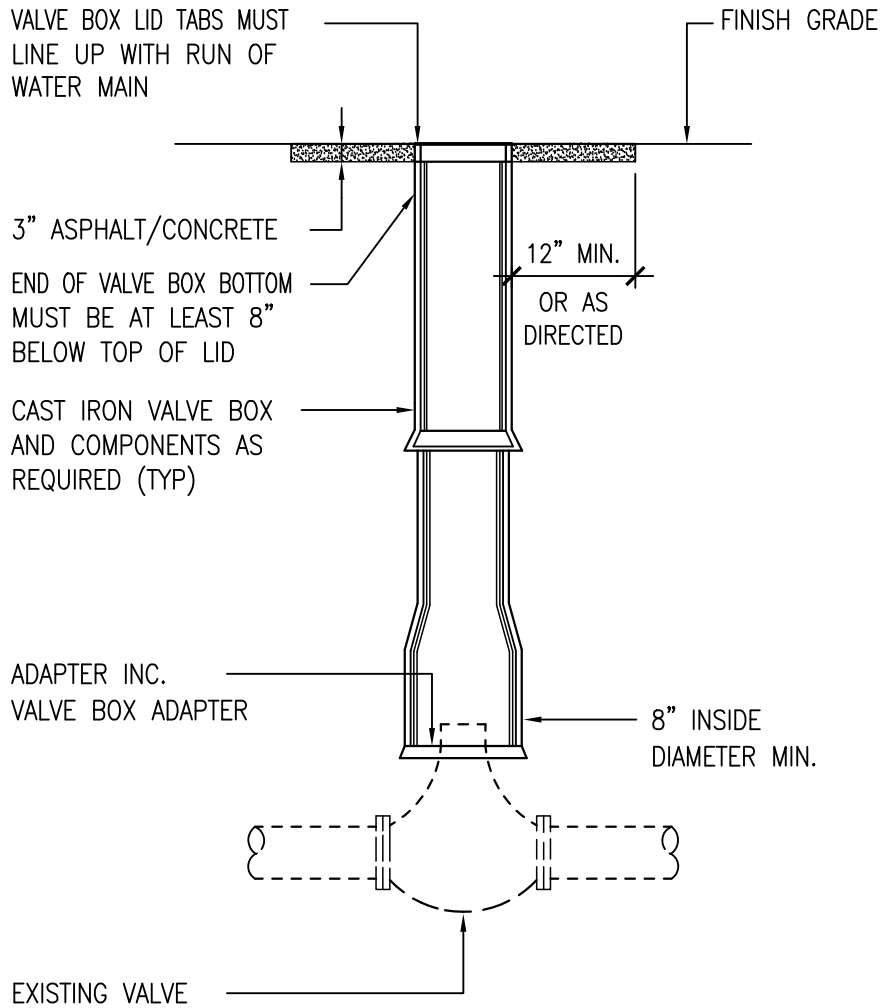

**NOTES:**

- ① VALVE BOXES SHALL BE TWO PIECE ADJUSTABLE CAST IRON WITH EXTENSION PIPE (IF NEEDED). "WATER" SHALL BE CAST IN RELIEF ON THE VALVE BOX TOP. VALVE BOX BOTTOM MUST FIT VALVE ADAPTER.
- ② ALL EXISTING CAST IRON VALVE BOXES SHALL BE ADJUSTED TO GRADE WITH CAST IRON COMPONENTS.
- ③ ALIGNMENT OF THE VALVE BOX SHALL BE THE CONTRACTORS RESPONSIBILITY AND CARE SHALL BE TAKEN TO ENSURE THAT THE VALVE MAY BE OPERATED.
- ④ VALVES DEEPER THAN 4' REQUIRE SOIL PIPE EXTENSIONS.

**MT. VIEW - EDGEWOOD WATER COMPANY  
STANDARD DETAIL IV-5**

**VALVE BOX  
ADJUSTMENT**



2010\2010928-MVE-WSP-STANDARDS\1V-6VLVOPRNUTEXT 1=1 3-23-11 RLD

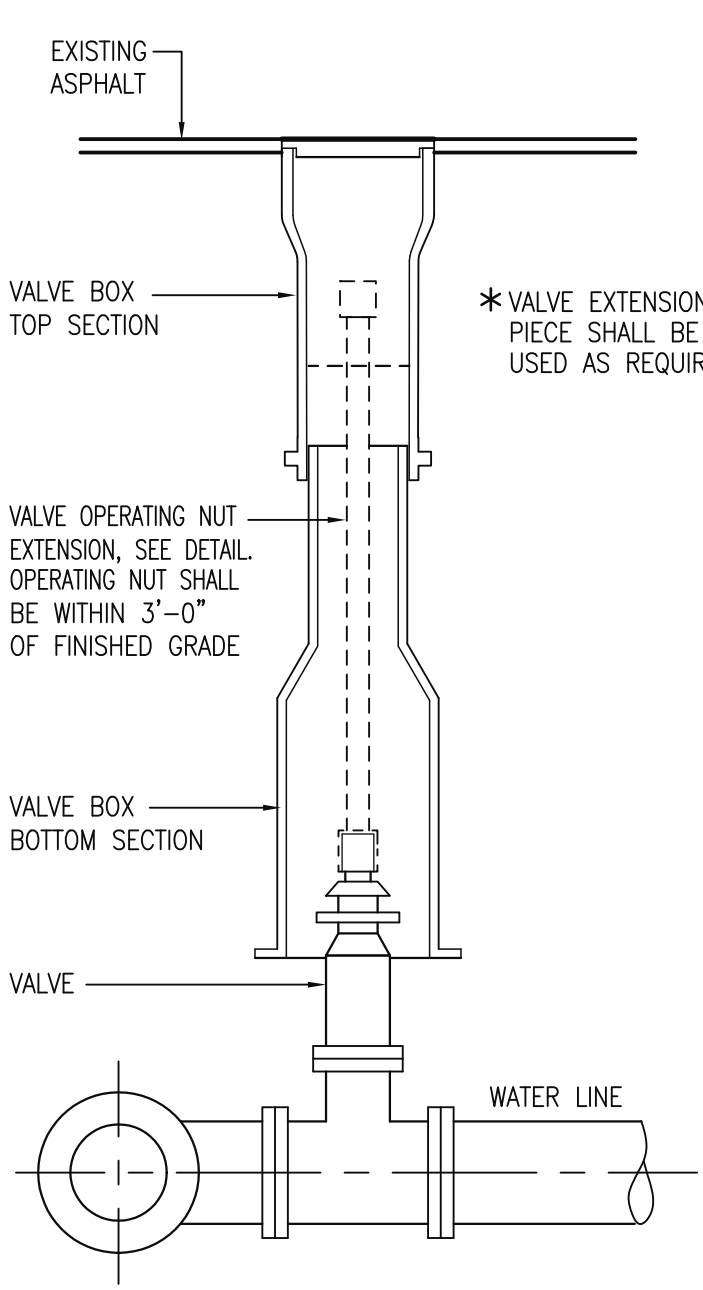

\* VALVE EXTENSION PIECE SHALL BE USED AS REQUIRED.

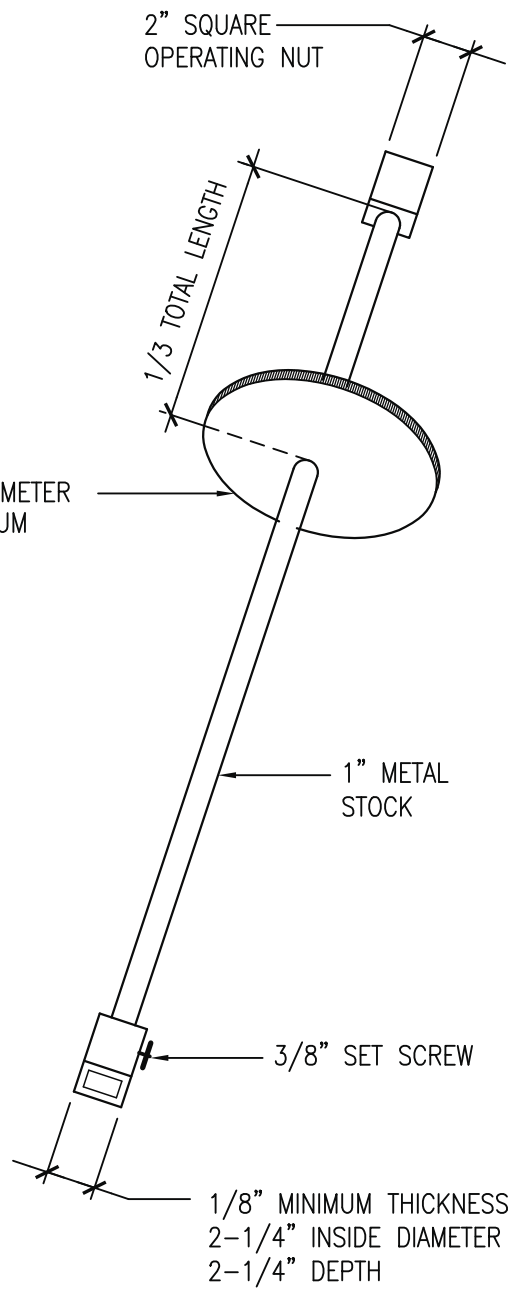

NOTES:

- ① VALVE OPERATING NUT EXTENSION IS REQUIRED WHEN THE VALVE NUT IS MORE THAN THREE (3) FEET BELOW FINISHED GRADE. EXTENSIONS ARE TO BE A MINIMUM OF ONE (1) FOOT LONG. ONLY ONE EXTENSION TO BE USED PER VALVE.
- ② ALL VALVE OPERATING NUT EXTENSIONS ARE TO BE MADE OF STEEL, SIZED AS NOTED, AND PAINTED WITH TWO (2) COATS OF ENAMEL PAINT.

**MT. VIEW - EDGEWOOD WATER COMPANY  
STANDARD DETAIL IV-6**

---

**VALVE OPERATING  
NUT EXTENSION**



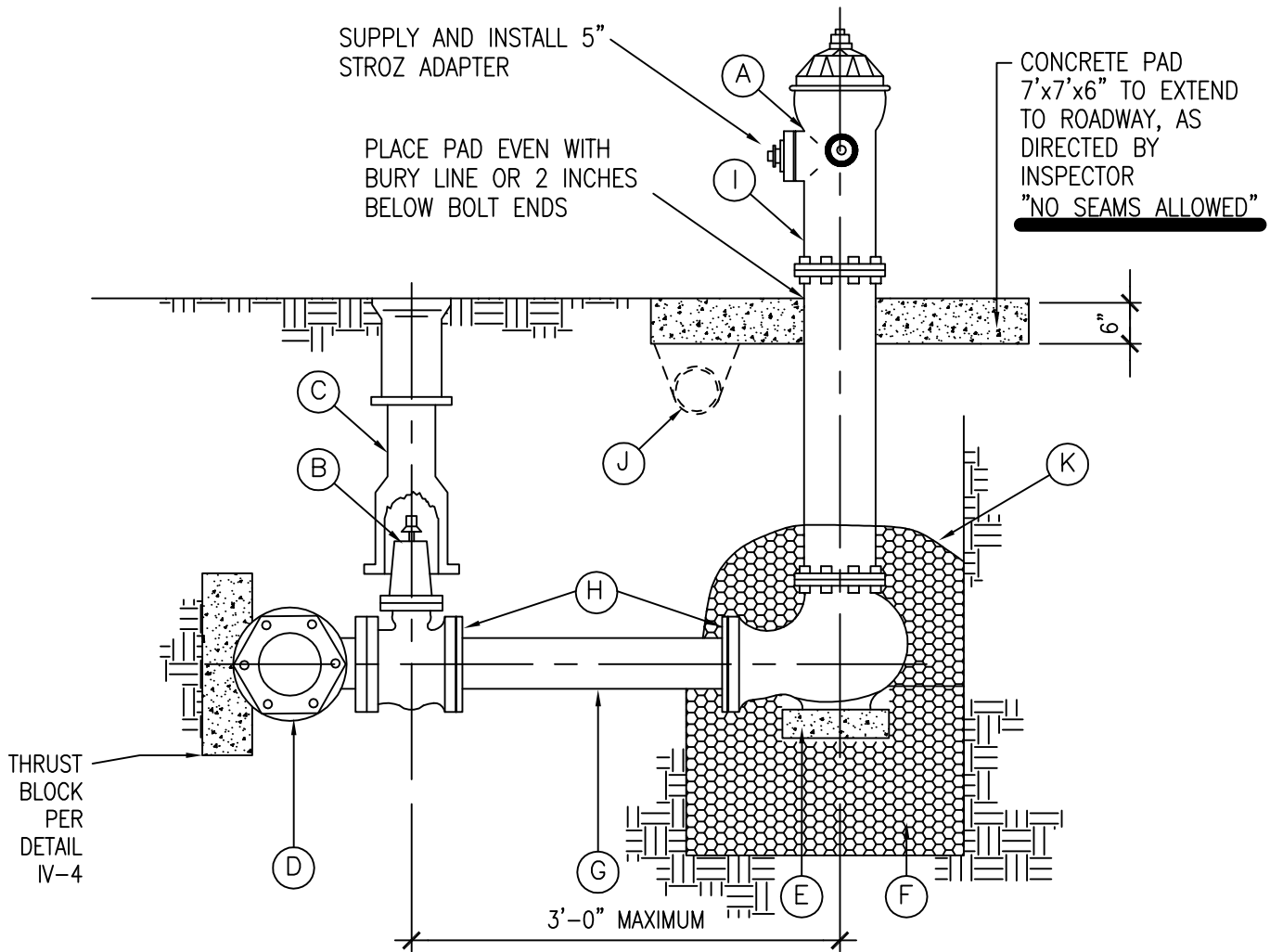

CALL OUT	QUANTITY	ITEM DESCRIPTION
A	1	FIRE HYDRANT: MUELLER "CENTURIAN" OR CLOW "MEDALLION"
B	1	AUXILIARY GATE VALVE: 6" PER STANDARD MJ X FL
C	1	VALVE BOX: PER DETAIL IV-5 AND DETAIL IV-6
D	1	TEE: 6" FLANGED OUTLET
E	1	CONCRETE BRICK 8" X 16" X 4"
F	1/4 CY	WASHED ROCK 1-1/4" MINUS
G	2' MAX.	6" DUCTILE IRON PIPE: CEMENT LINED, CLASS 52
H	2	MEGA-LUGS
I		HYDRANTS SHALL BE PAINTED WITH TWO COATS OF SAFETY YELLOW
J		IN LOCATION WHERE HYDRANT LINE CROSSES DITCH INSTALL 10 FEET OF CULVERT AND FILL AREA OVER CULVERT, CULVERT SIZE TO BE DETERMINED BY CITY OF EDGEWOOD PUBLIC WORKS.
K		COVER WASHED ROCK WITH FILTER FABRIC

**MT. VIEW - EDGEWOOD WATER COMPANY  
STANDARD DETAIL IV-7**

**FIRE HYDRANT ASSEMBLY**

2010\2010928-MVE-WSP-STANDARDS\1V-8ACREPAIR 1=1 3-23-11 RLD

\*3" MINIMUM ASPHALT CLASS "B" THICKNESS TO BE 1" GREATER THAN EXISTING - TO A MAXIMUM OF 6".

ALL EDGES TO BE CUT IN SMOOTH STRAIGHT LINES PRIOR TO PAVEMENT REPAIR, THE LIMITS OF PAVING WILL BE DETERMINED BY THE CITY OF EDGEWOOD INSPECTOR. CALL PRIOR TO MAKING FINAL CUT.

DAMAGED SECTION PAVEMENT LIMIT  
6'-0"

12"  
MIN.

12"  
MIN.

CLEAN AND TACK ALL ASPHALT EDGES PRIOR TO PAVING. SEAL ALL JOINTS AFTER PAVING WITH CSS-1 EMULSIFIED ASPHALT

EXISTING PAVEMENT

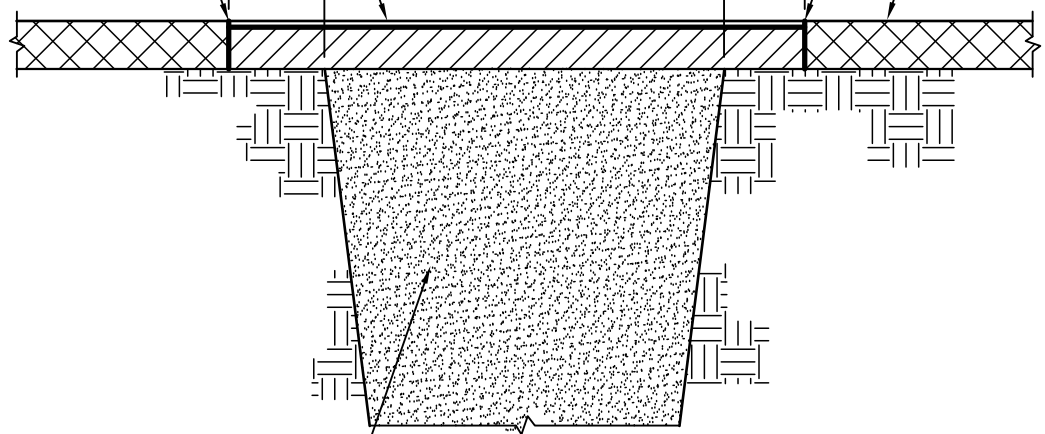

COMPACTED BACKFILL CONSISTING OF 5/8" CRUSHED GRAVEL OR C.D.F. AS DIRECTED

\*PAVING TO BE DONE AS REQUIRED BY THE CITY OF EDGEWOOD PUBLIC WORKS DIRECTOR

MT. VIEW - EDGEWOOD WATER COMPANY  
STANDARD DETAIL IV-8

ASPHALT PAVEMENT  
REPAIR WITHOUT OVERLAY



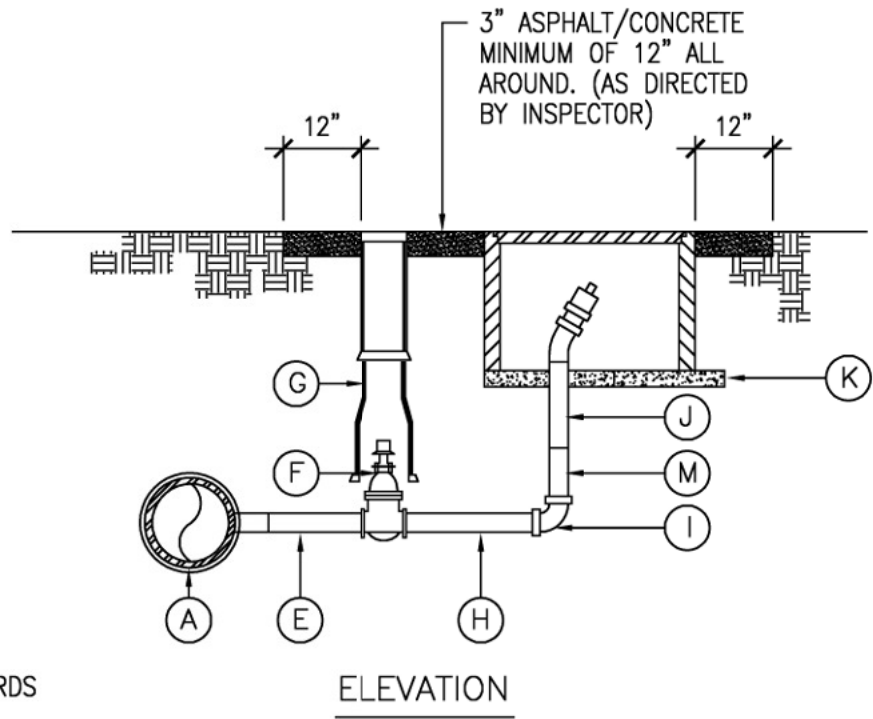
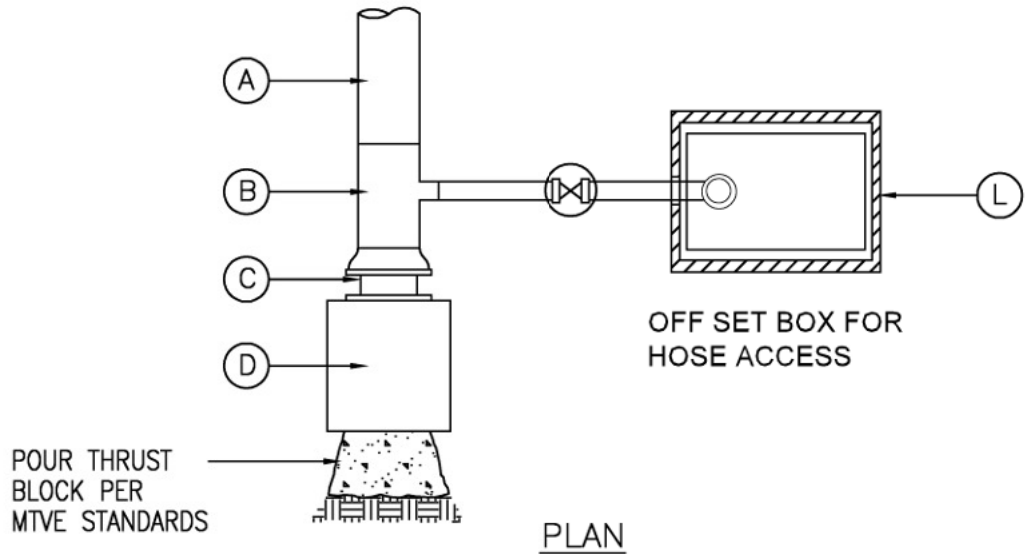

- (A) EXISTING MAIN
- (B) MJ TEE, REDUCED TO 2" FIP
- (C) CAP OR PLUG (MJ)
- (D) ECOLOGY BLOCK
- (E) 2"x8" BRASS NIPPLE
- (F) 2" GATE VALVE PER MTVE STANDARDS
- (G) VALVE BOX, CAST IRON SLIDE EXTENSION PER DETAIL IV-5
- (H) 2"x12" BRASS NIPPLE
- (I) 2 - 2" 90° ST ELL BRASS "SWING JOINT"
- (J) KUPFERLE BLOW OFF HYDRANT #78
- (K) 1-1/2"x8"x16" CONCRETE PADS
- (L) CARSON 1527 X 12 BCF WITH FIBRELITE LID
- (M) 2" BRASS NIPPLE, AS NEEDED, TO ADJUST TO GRADE

**NOTE:**

ABOVE GROUND BLOW-OFF OR AUTOMATIC BLOW-OFF MAY BE REQUIRED. REFER TO APPROVED PLANS.

**NSF NOTE:**

ALL FITTINGS AND PARTS MUST COMPLY WITH NSF/ANSI 61 ANNEX G & NSF/ANSI 372

**MT. VIEW - EDGEWOOD WATER COMPANY  
STANDARD DETAIL IV - 9**

**2" BLOW OFF**

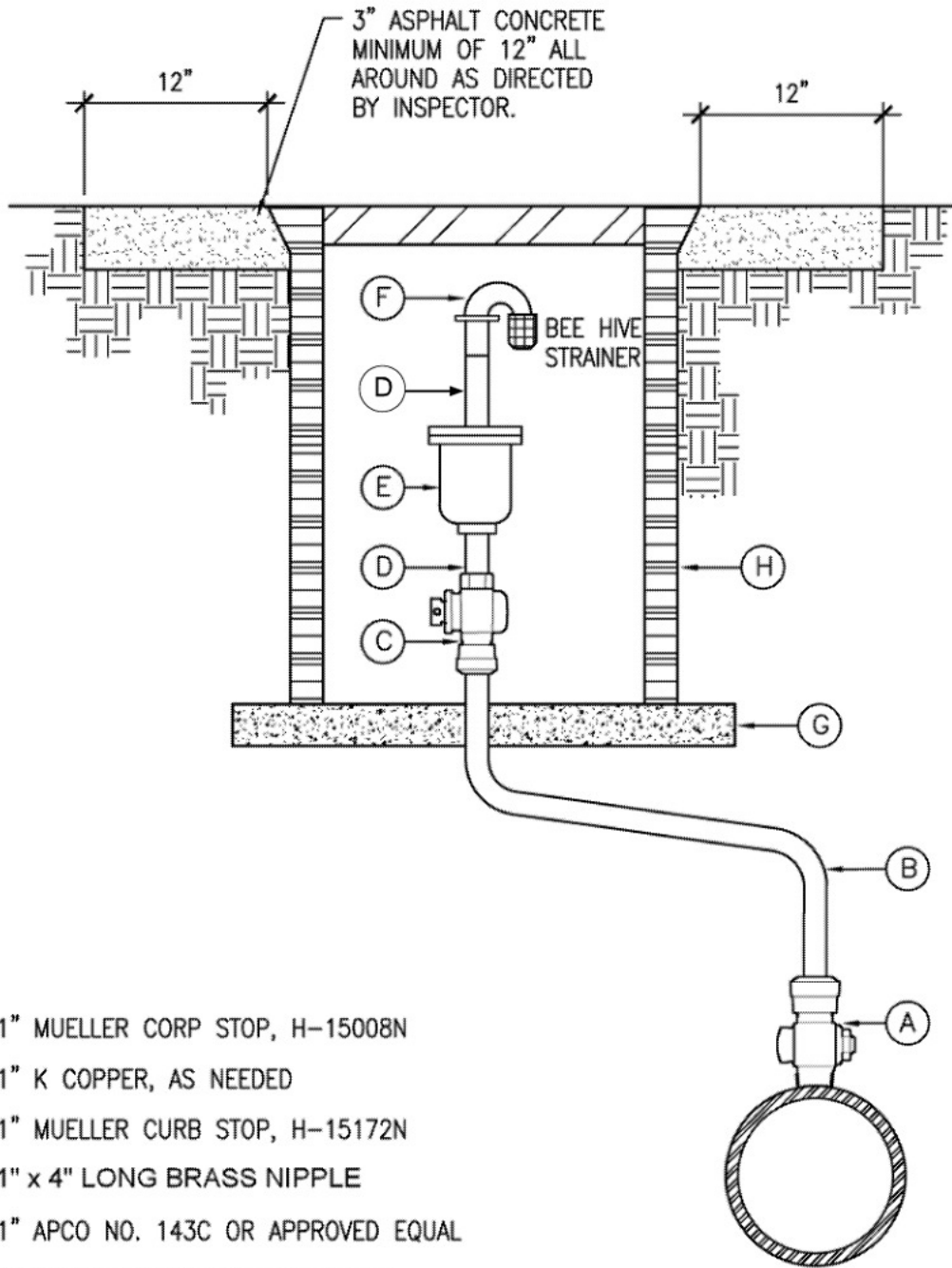

- (A) 1" MUELLER CORP STOP, H-15008N
- (B) 1" K COPPER, AS NEEDED
- (C) 1" MUELLER CURB STOP, H-15172N
- (D) 1" x 4" LONG BRASS NIPPLE
- (E) 1" APCO NO. 143C OR APPROVED EQUAL
- (F) IF GROUND WATER TABLE IS BELOW AIR VAC, INSTALL 180° BELOW COVER. OTHERWISE INSTALL 180° ELL WITH BEE HIVE STRAINER ABOVE COVER AND PROTECT
- (G) 1-1/2"x8"x16" CONCRETE PADS
- (H) 1 - 1527BCF X 12 15272525  
1 - 1527BCF X 18 15272525  
1 - FIBRELYTE LID 02001437

NSF NOTE:

ALL FITTINGS AND PARTS MUST COMPLY WITH NSF/ANSI 61 ANNEX G & NSF/ANSI 372

MT. VIEW - EDGEWOOD WATER COMPANY  
STANDARD DETAIL IV - 10

1" AIR AND VACUUM  
RELEASE ASSEMBLY



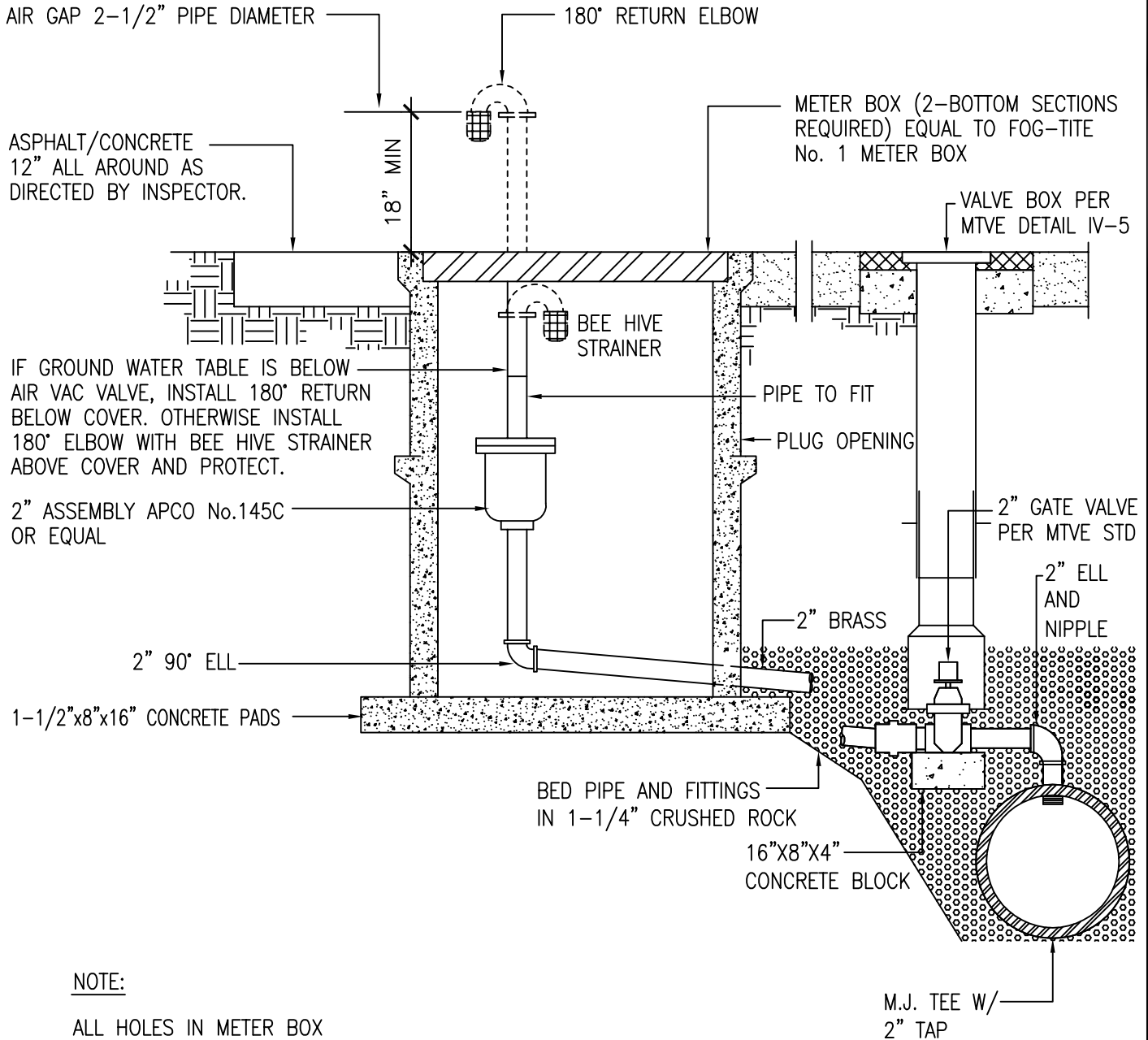

**NSF NOTE:**  
ALL FITTINGS AND PARTS MUST COMPLY WITH  
NSF/ANSI 61 ANNEX G & NSF/ANSI 372

**MT. VIEW - EDGEWOOD WATER COMPANY  
STANDARD DETAIL IV - 11**

---

**2" AIR AND VACUUM  
RELEASE ASSEMBLY**

2010\2010928-WE-WSP\STANDARDS\W-11-2AVR 1=1 7-20-21 CMC



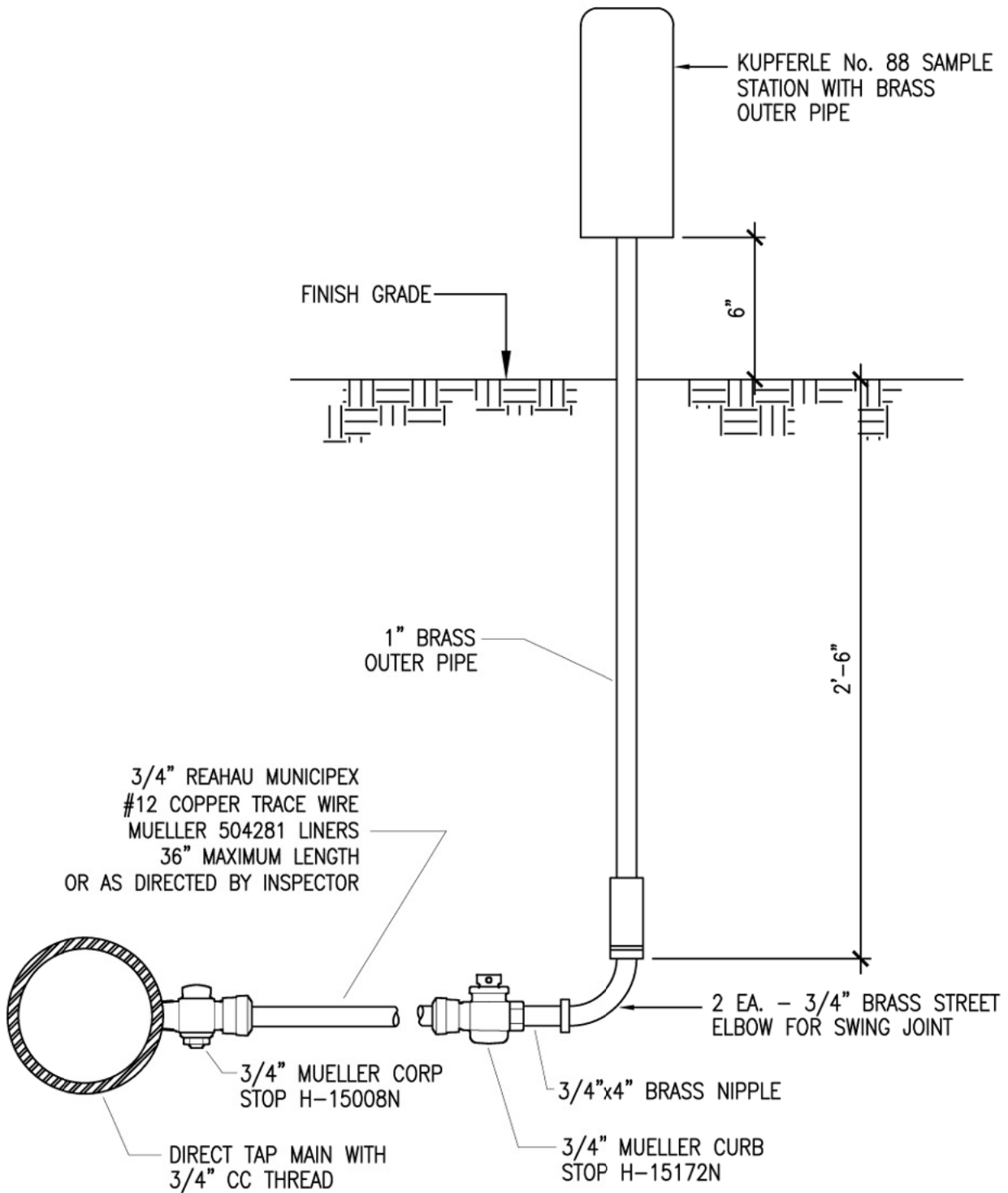

**NSF NOTE:**  
 ALL FITTINGS AND PARTS MUST COMPLY WITH  
 NSF/ANSI 61 ANNEX G & NSF/ANSI 372

**MT. VIEW - EDGEWOOD WATER COMPANY  
 STANDARD DETAIL IV - 12**

---

**WATER  
 SAMPLING STATION**



KUPERFLE ECLIPSE #88

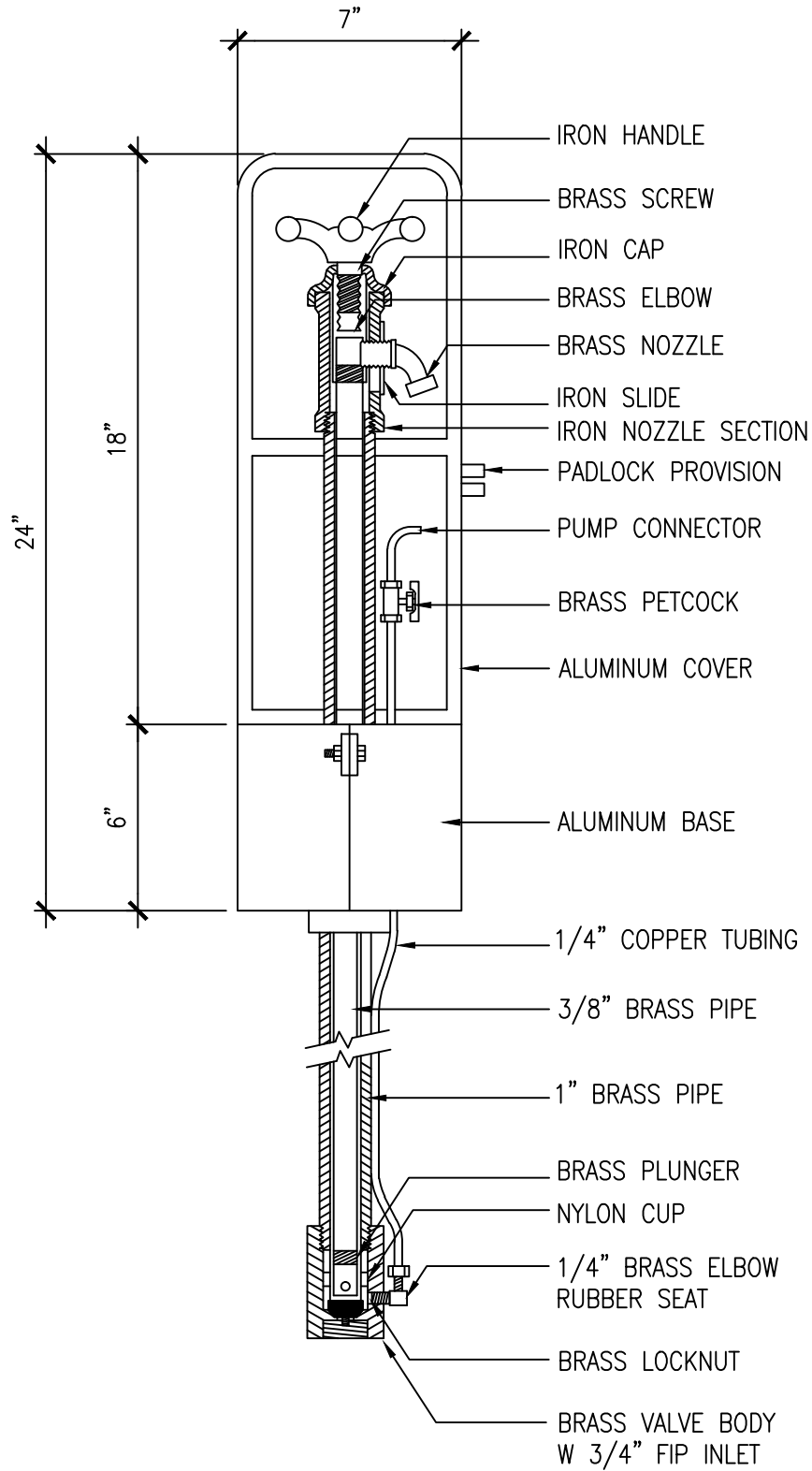

MT. VIEW - EDGEWOOD WATER COMPANY  
STANDARD DETAIL IV - 13

WATER  
SAMPLING STATION

NOTES:

1. INSTALL 1-1/2" SCH 40 PVC BETWEEN CLUSTERED BOXES AS DIRECTED
2. SET METER BOX PADS ON COMPACTED SAND
3. BACKFILL ENTIRE SERVICE WITH SAND

METER BOX	COVER
OLD CASTLE 1527BCF X 18" 15272525 NO MOUSE HOLES	OLD CASTLE FIBRELYTE WITH AMR HOLE 02001407 or 02001437

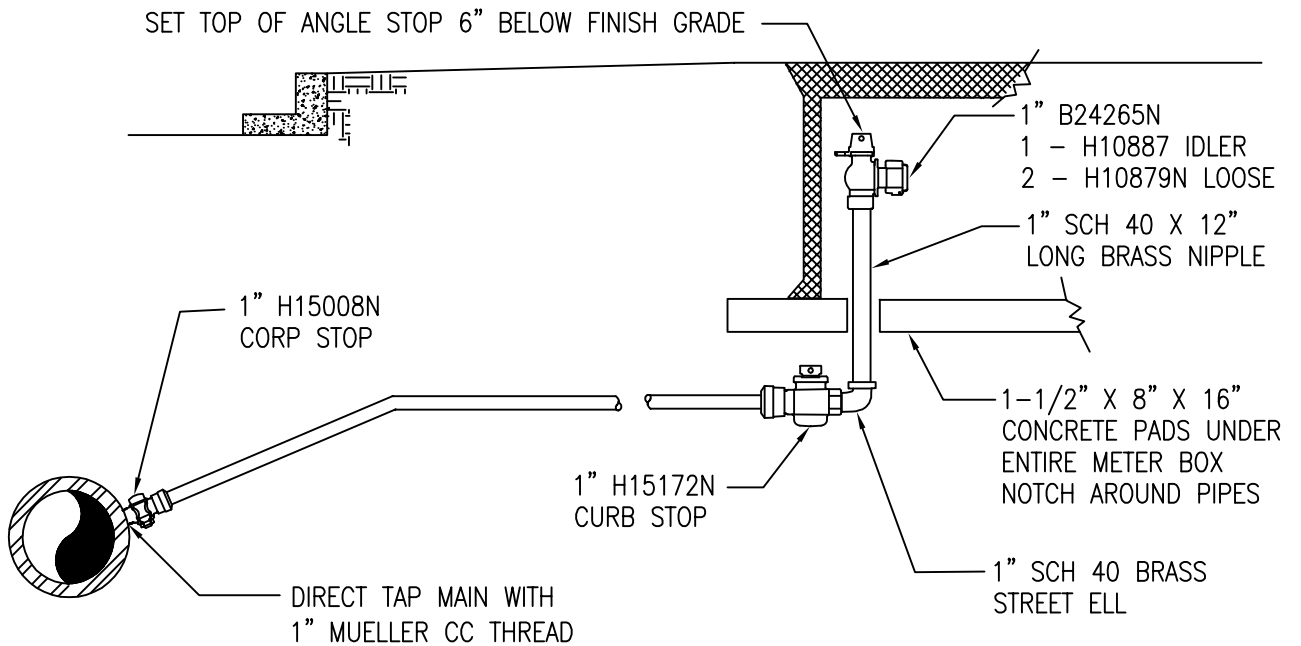
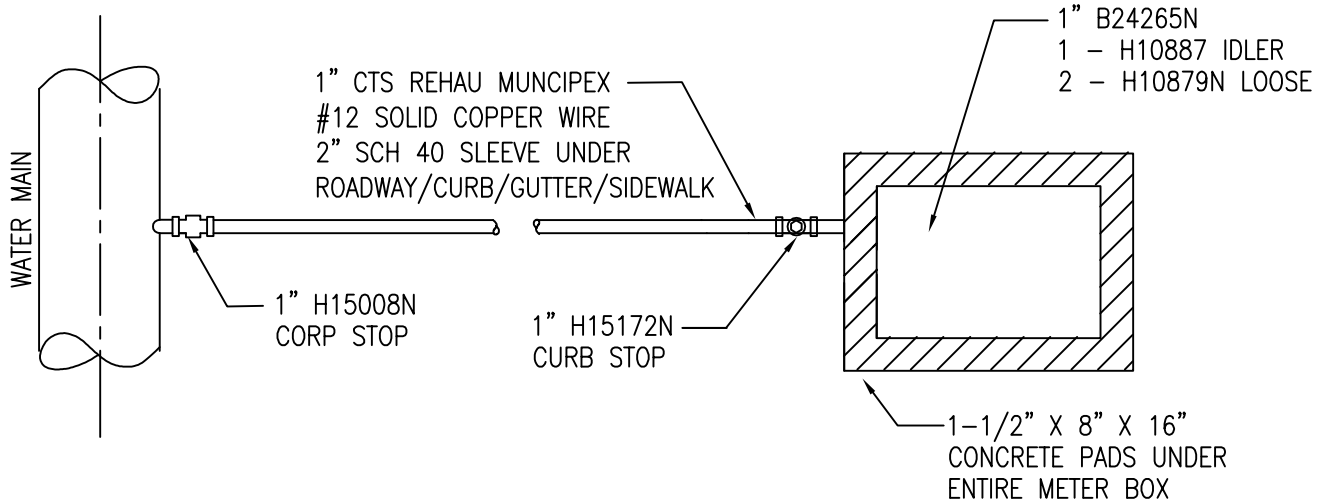

NSF NOTE:

ALL FITTINGS AND PARTS MUST COMPLY WITH NSF/ANSI 61 ANNEX G & NSF/ANSI 372

REVISED 3-22-21 CMC  
SUPERSEDES ALL PREVIOUS  
VERSIONS

NOT TO SCALE

**MT. VIEW - EDGEWOOD WATER COMPANY  
STANDARD DETAIL IV - 14**

**3/4" AND 1" SINGLE  
METER SERVICE**

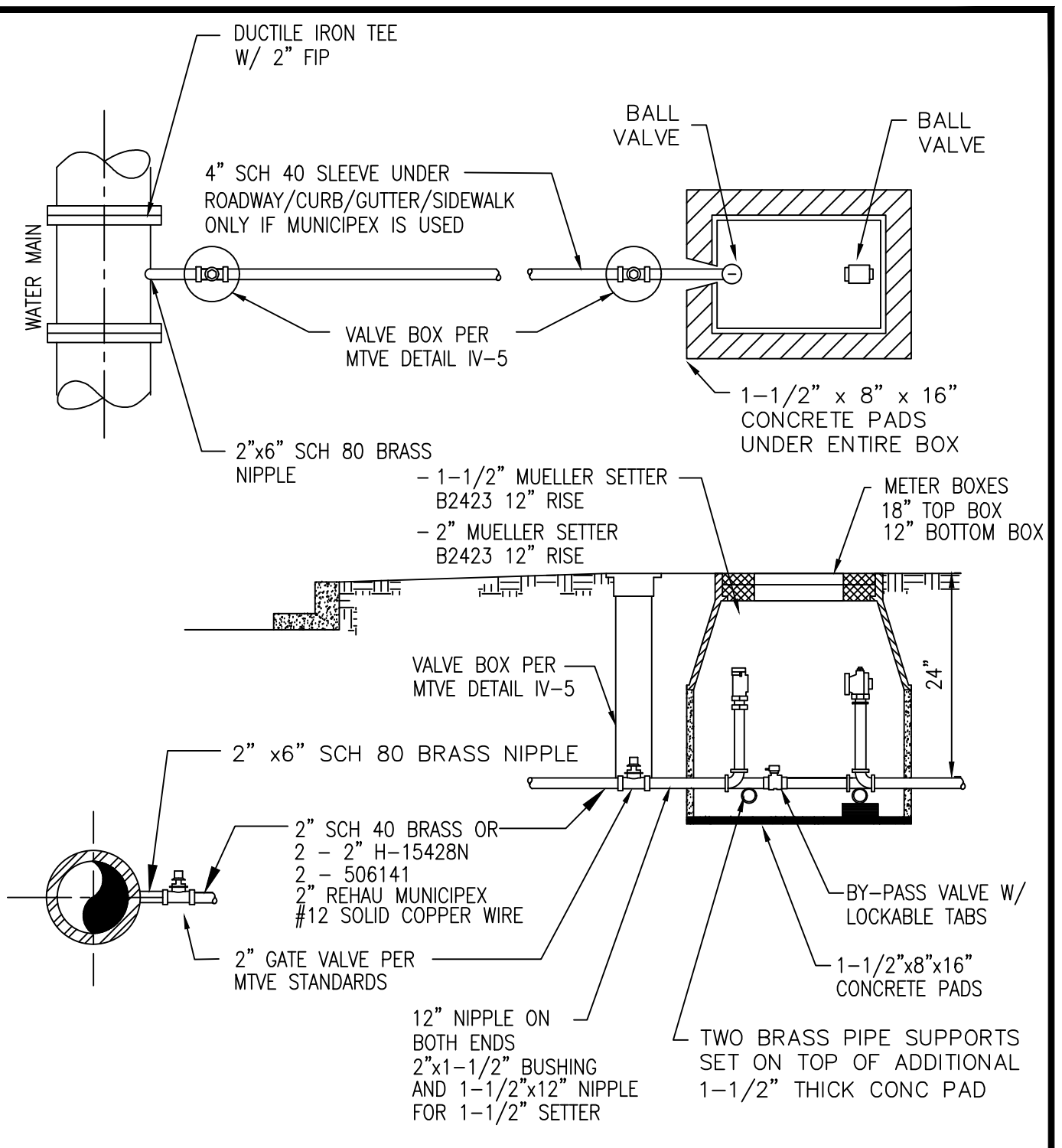

METER BOX	COVER
OLD CASTLE 1730BCF X 18" 17302520 NO MOUSE HOLES and 1730BCF X 12" 17302500 MOUSE HOLES	OLD CASTLE FIBRELYTE WITH SENSUS AMR HOLE 02001573

**NSF NOTE:**  
 ALL FITTINGS AND PARTS MUST COMPLY WITH  
 NSF/ANSI 61 ANNEX G & NSF/ANSI 372

**MT. VIEW - EDGEWOOD WATER COMPANY  
 STANDARD DETAIL IV - 16**

---

**1-1/2" and 2" STANDARD COPPER  
 SETTER WITH BYPASS**

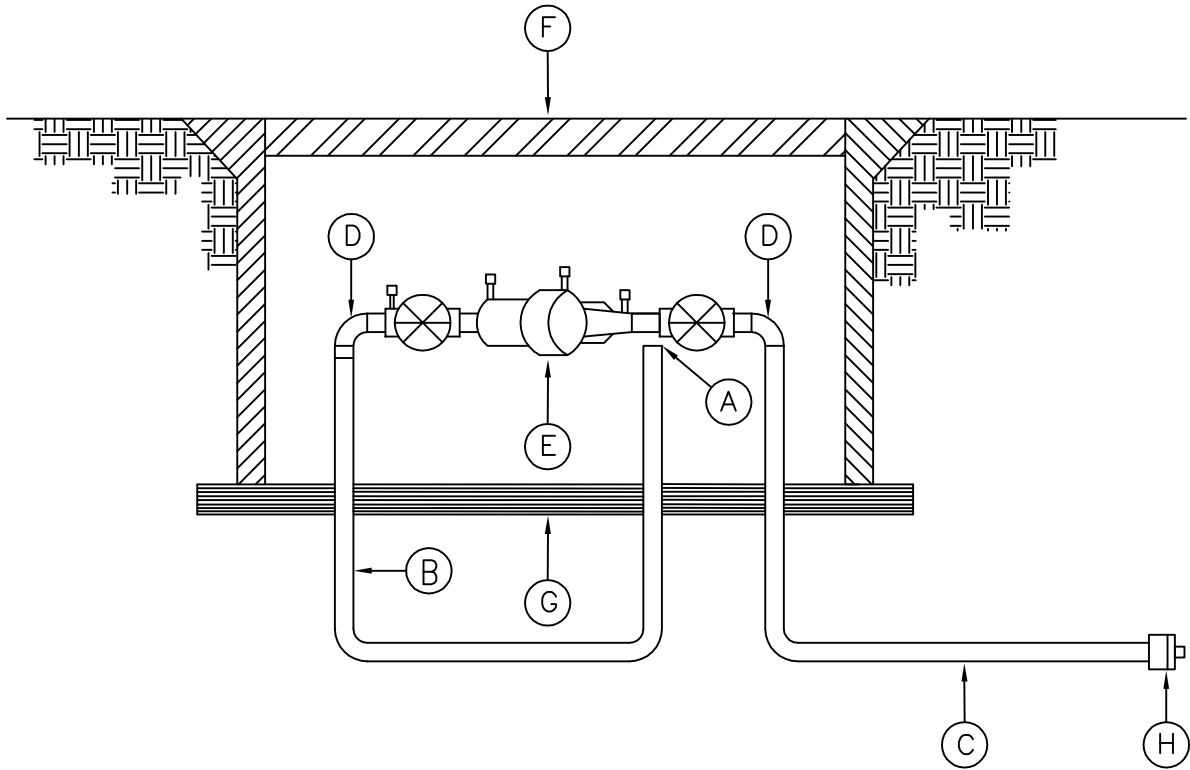

- (A) 1" H14206N QUARTER BEND WITH METER NUT
- (B) 1" K COPPER BENT TO MTVE PATTERN
- (C) 1" K COPPER BENT TO MTVE PATTERN
- (D) 1" H15531N
- (E) 1" WILKINS 950XL3U DCVA WITH STAINLESS STEEL HANDLES
- (F) INSTALL IN SAME BOX AS METER IV-14
- (G) 1-1/2"x8"x16" CONCRETE PADS UNDER ENTIRE METER BOX  
CUT AS NEEDED TO FIT AROUND COPPER RISERS  
OPTION - CENTER PADS UNDER METER BOX EDGES  
PLACE PIPE FOAM AROUND COPPER RISERS  
FILL CENTER WITH 1-1/2" OF MOTOR MIX (NOT CONCRETE)
- (H) 1" H15451N WITH PVC PLUG

NOT TO SCALE

REVISED 11-15-22 CMC  
SUPERCEDES ALL  
PREVIOUS VERSIONS

**NSF NOTE:**

ALL FITTINGS AND PARTS MUST COMPLY WITH  
NSF/ANSI 61 ANNEX G & NSF/ANSI 372

**MT. VIEW - EDGEWOOD WATER COMPANY  
STANDARD DETAIL IV - 17**

**1" PREMISES  
ISOLATION D.C.V.A.**

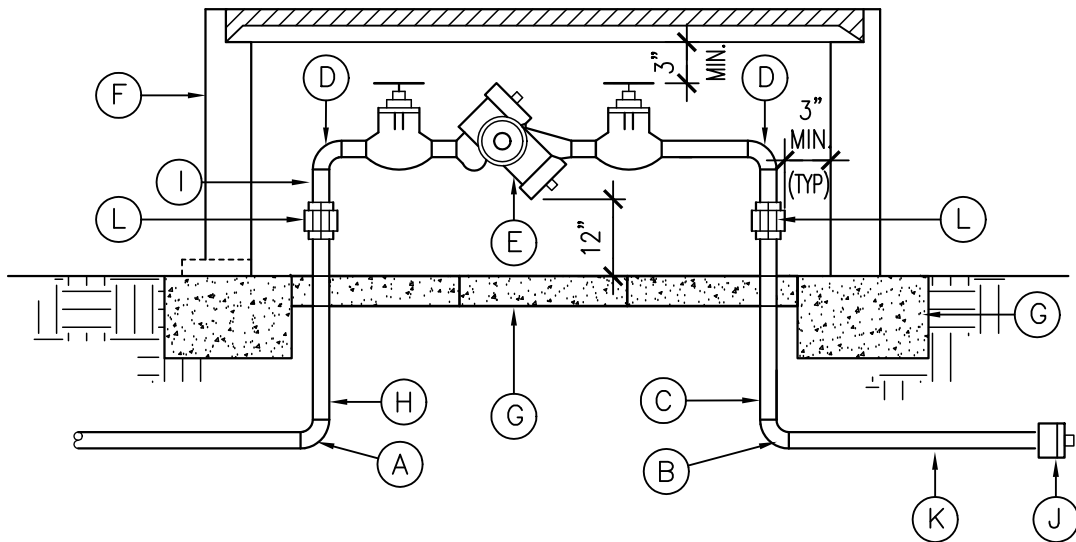

- |  |  |
|--|--|
| (A) BRASS ELL 3/4" H-15533N (1" ON 1" SETTER)        | (G) 2"x8"x16" CONCRETE PADS, FIT AROUND NIPPLES                          |
| (B) 1" BRASS ELL H-15533N                            | (H) 3/4" BRASS NIPPLE, AS NEEDED (1" USED ON 1" SETTER)                  |
| (C) 1" BRASS NIPPLE, 12" LONG                        | (I) BRASS BUSHING 3/4"x1" (NOT USED ON 1" SETTER)                        |
| (D) 1" BRASS 90° ST ELL                              | (J) ADAPTER, 1" H-15451N WITH 1" PLUG, OR ADAPT TO EXISTING SERVICE LINE |
| (E) 1" RPBA, WILKINS 975XL2                          | (K) 4'-0" OF 1" TYPE K COPPER  |
| (F) HOT BOX, OWNER RESPONSIBLE FOR FREEZE PROTECTION | (L) BRASS UNION  |

NOTES:

1. THE RPBA SHALL BE INSTALLED WITH A MINIMUM OF 3'-0" CLEAR SPACE ON ALL SIDES TO FACILITATE MAINTENANCE AND TESTING. IT SHALL BE TESTED AFTER INSTALLATION, BY A WASHINGTON STATE CERTIFIED BACKFLOW ASSEMBLY TESTER, TO INSURE ITS SATISFACTORY OPERATION BEFORE OCCUPANCY AND ANNUALLY THEREAFTER.
2. AN RPBA SHALL NOT BE INSTALLED IN A PIT BELOW GROUND LEVEL.
3. THE PROTECTIVE COVERING FOR THE RPBA MUST INCLUDE A DAYLIGHT DRAIN. THE DRAIN MUST ALSO BE ABLE TO HANDLE THE VOLUME OF WATER THAT POTENTIALLY COULD BE DISCHARGED FROM THE RELIEF VALVE PORT.
4. HOT BOX SHALL BE SUPPORTED BY FOUR 16" X 8" X 4" SOLID CONCRETE BLOCKS.
5. RPBA SHALL BE PROTECTED FROM FREEZING. FREEZE PROTECTION SHALL BE MAINTAINED BY OWNER.

NSF NOTE:

ALL FITTINGS AND PARTS MUST COMPLY WITH NSF/ANSI 61 ANNEX G & NSF/ANSI 372

MT. VIEW - EDGEWOOD WATER COMPANY  
STANDARD DETAIL IV - 18

1" PREMISES  
ISOLATION RPBA



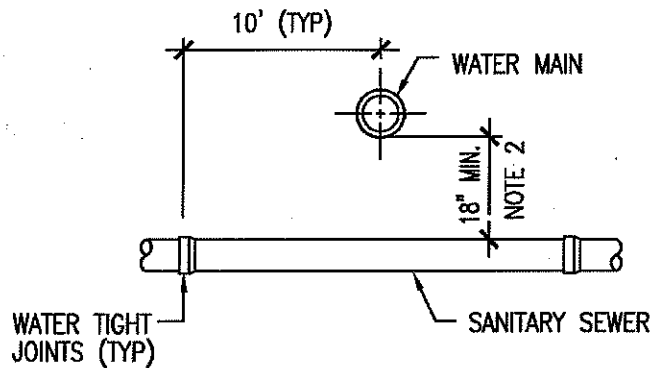
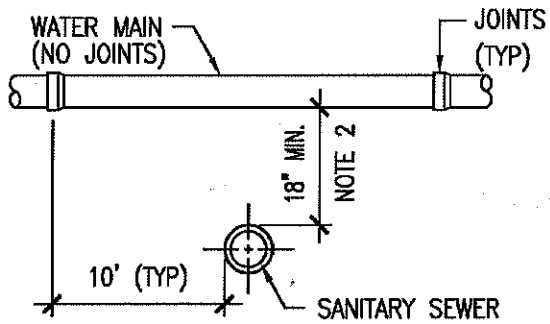

**WATER MAIN CROSSING ABOVE SANITARY SEWER**

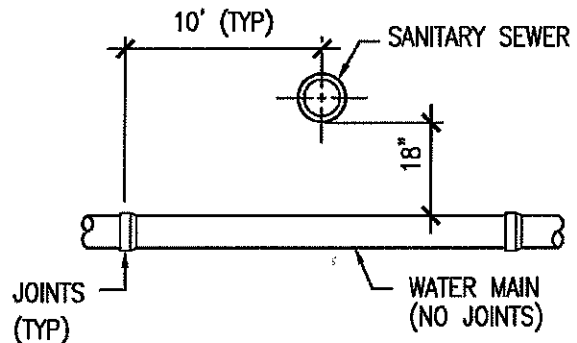
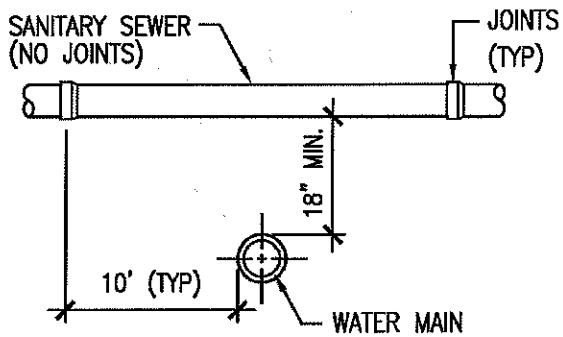

**WATER MAIN CROSSING BELOW SANITARY SEWER**

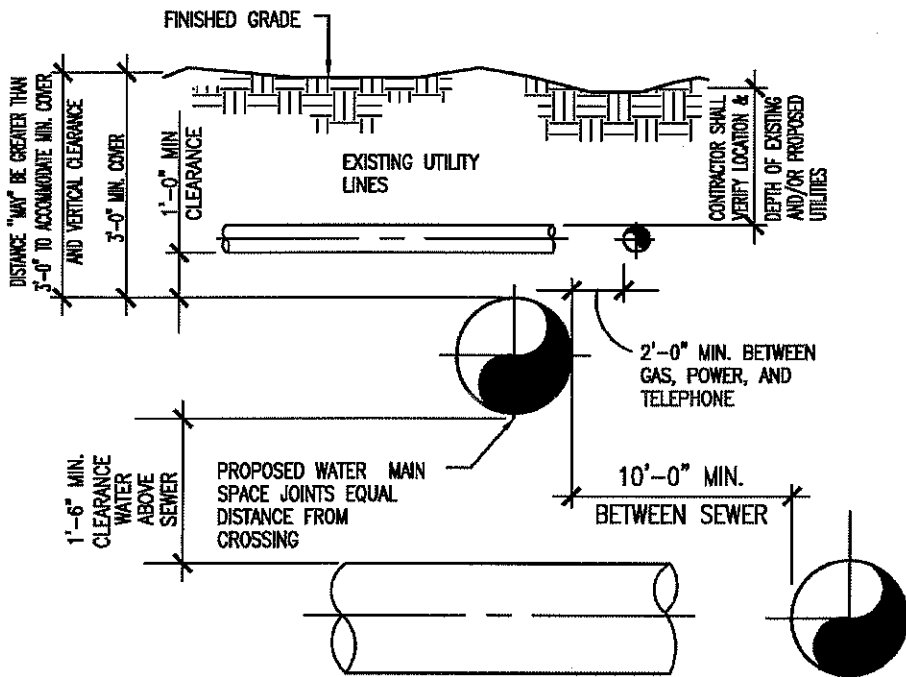

**NOTES:**

1. REGULATORY AGENCY REQUIREMENTS SHALL SUPERSEDE WATER COMPANY STANDARDS IF MORE STRINGENT.
2. IF MINIMUM HORIZONTAL OR VERTICAL SEPARATIONS NOTED CANNOT BE MET THE SEWER WILL BE SLEEVED AS SHOWN IN THE SLEEVE DETAIL.

**MT. VIEW - EDGEWOOD WATER COMPANY  
STANDARD DETAIL IV - 19 (1 OF 3)**

**WATER MAIN  
CROSSING SEWER PIPE**





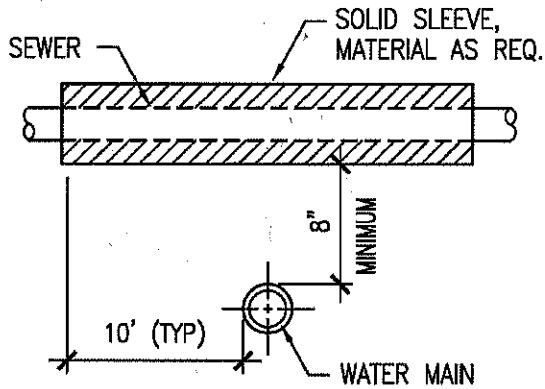

SEWER PIPE SLEEVE DETAIL

NOTE:

SLEEVE SHALL BE ONE QUARTER INCH THICK CONTINUOUS STEEL, DUCTILE IRON, OR PRESSURE RATED PVC PIPE WITH A DIMENSION RATIO (DR) (THE RATIO OF THE OUTSIDE DIAMETER TO THE PIPE WALL THICKNESS) OF 18 OR LESS, WITH ALL VOIDS PRESSURE-GROUTED WITH SAND-CEMENT GROUT OR BENTONITE. COMMERCIALY AVAILABLE PIPE SKIDS AND END SEALS ARE ACCEPTABLE. WHEN USING STEEL OR DUCTILE IRON CASING DESIGN CONSIDERATION FOR CORROSION PROTECTION SHALL BE CONSIDERED.

MT. VIEW - EDGEWOOD WATER COMPANY  
STANDARD DETAIL IV - 19 (2 OF 3)

WATER MAIN  
CROSSING SEWER PIPE NOTES



**TYPICAL SPECIAL PROTECTION FOR WATER MAIN CROSSING WITH SANITARY SEWER,  
PVC STORM DRAIN, OR EFFLUENT LINE**

WATER MAIN CROSSING WITH RCP STORM DRAIN

WATER MAIN MUST CROSS A MINIMUM OF 18" ABOVE A RCP STORM DRAIN. IF THIS IS IMPRACTICAL AND IF THE STORM DRAIN CROSSES ABOVE THE WATER MAIN, OR BELOW BY LESS THAN 18", THE FOLLOWING SPECIAL CONSTRUCTION METHODS MAY BE USED:

- A. IF THE RCP STORM DRAIN IS LESS THAN 24" DIA., THEN CONCRETE ENCASE THE JOINTS OF THE RCP STORM DRAIN 10' EITHER SIDE OF THE CROSSING AND CENTER THE WATER MAIN JOINTS.
- B. IF THE RCP STORM DRAIN IS 24" DIA. OR LARGER, THEN USE JOINT SEALANTS OR JOINT GASKETS THAT MEET ASTM D3212 STANDARDS ON THE STORM DRAIN MAIN AND CENTER THE WATER MAIN JOINTS.

WATER MAIN CROSSING WITH SANITARY SEWER MAIN AND PVC STORM DRAIN

WATER MAIN MUST CROSS A MINIMUM OF 18" ABOVE A SANITARY SEWER MAIN. IF THIS IS IMPRACTICAL AND IF THE SANITARY SEWER MAIN CROSSES ABOVE THE WATER MAIN, OR BELOW BY LESS THAN 18", THE FOLLOWING SPECIAL CONSTRUCTION METHODS MAY BE USED:

- A. SLEEVE THE SEWER OR STORM DRAIN MAIN WITH WATER QUALITY PIPE OR CENTER SEWER OR STORM DRAIN JOINTS WITH WATER MAIN. SEWER AND STORM DRAIN PIPES MUST HAVE WATER TIGHT JOINTS THAT COMPLY WITH ASTM D3212.

SLEEVING IS TO BE 10' EITHER SIDE OF THE WATER PIPE (A TOTAL OF 20') AND TO AVOID BEING GROUTED IN PLACE, THE MAIN INSIDE THE SLEEVE MUST HAVE A DIAMETER EQUAL TO OR GREATER THAN 2/3 THE DIAMETER OF THE SLEEVE.

WATER MAIN CROSSING WITH SANITARY SEWER LATERAL

WATER MAIN MUST CROSS A MINIMUM OF 12" ABOVE A SANITARY SEWER LATERAL. IF THIS IS IMPRACTICAL AND IF THE SANITARY SEWER LATERAL CROSSES ABOVE THE WATER MAIN, OR BELOW BY LESS THAN 12", THE FOLLOWING SPECIAL CONSTRUCTION METHODS MAY BE USED:

- A. CENTER THE WATER MAIN JOINTS AND SLEEVE THE SANITARY SEWER LATERAL; OR
- B. CENTER THE WATER MAIN JOINTS AND CENTER THE SANITARY SEWER LATERAL PIPE JOINTS.

SLEEVING IS TO BE 10' EITHER SIDE OF THE WATER PIPE (A TOTAL OF 20') AND TO AVOID BEING GROUTED IN PLACE, THE LATERAL INSIDE THE SLEEVE MUST HAVE A DIAMETER EQUAL TO OR GREATER THAN 2/3 THE DIAMETER OF THE SLEEVE.

WATER SERVICE CROSSING WITH SANITARY SEWER MAIN

WATER SERVICE MUST CROSS A MINIMUM OF 18" ABOVE A SANITARY SEWER MAIN. IF THIS IS IMPRACTICAL AND IF THE SANITARY SEWER MAIN CROSSES ABOVE THE WATER SERVICE, OR BELOW BY LESS THAN 18", THE FOLLOWING SPECIAL CONSTRUCTION METHODS MAY BE USED:

- A. THE WATER SERVICE MUST BE POLYETHYLENE (PE) PIPE CONFORMING TO AWWA STANDARD C901-88 AND ASTM D2737 AND SEWER MAIN MUST BE SLEEVED OR HAVE JOINTS CENTERED OVER WATER SERVICE.

SLEEVING IS TO BE 10' EITHER SIDE OF THE WATER PIPE (A TOTAL OF 20') AND TO AVOID BEING GROUTED IN PLACE, THE MAIN INSIDE THE SLEEVE MUST HAVE A DIAMETER EQUAL TO OR GREATER THAN 2/3 THE DIAMETER OF THE SLEEVE.

**MT. VIEW - EDGEWOOD WATER COMPANY  
STANDARD DETAIL IV - 19 (3 OF 3)**



**WATER MAIN  
CROSSING SEWER PIPE NOTES**

2" WILKINS 375DA-LM  
 BRASS FITTINGS, AS NEEDED  
 $\frac{3}{4}$ " SENSUS iPerl READING IN C.F.  
 SENSUS 520M, MOUNTED THROUGH ENCLOSURE  
 INSULATED ENCLOSURE, AS NEEDED  
 HEAT TAPE OR HEATER  
 CONCRETE PAD

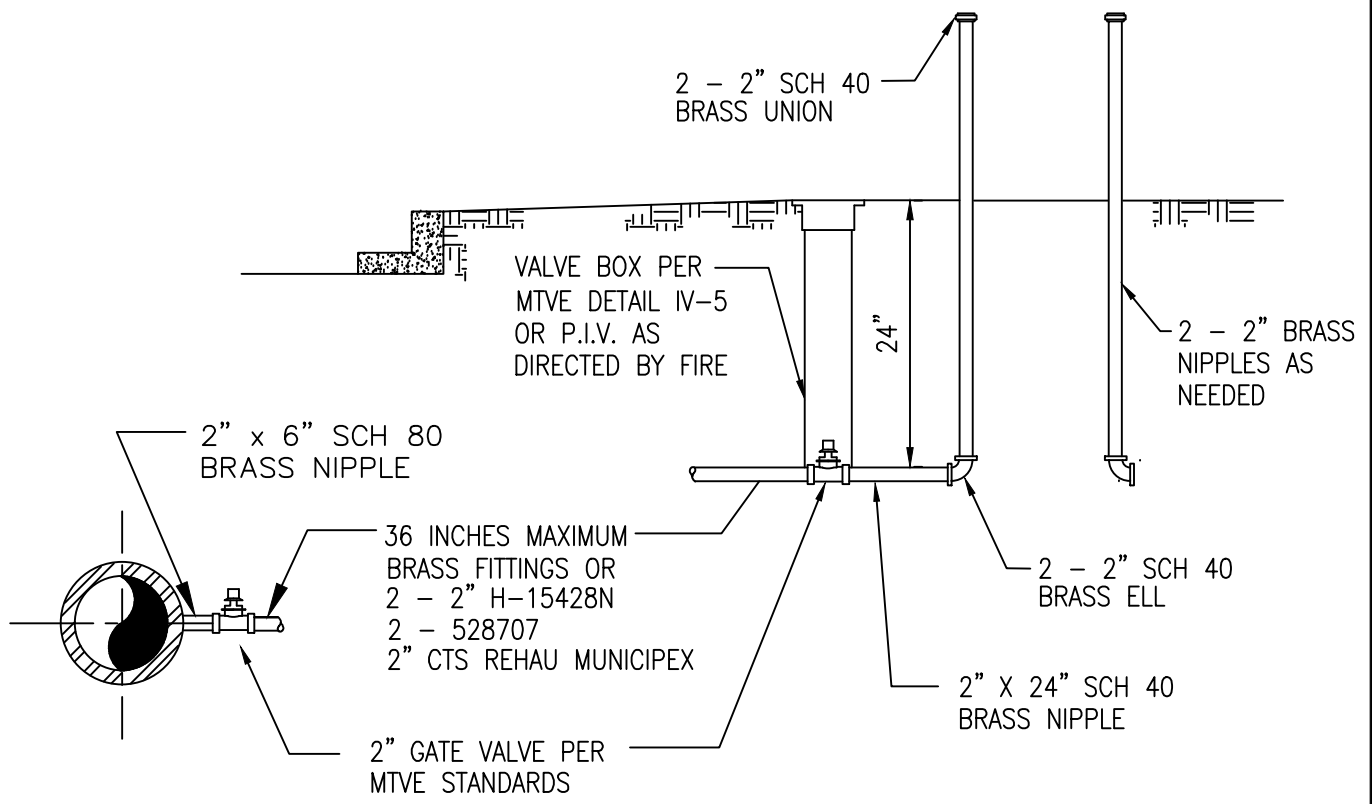

NOT TO SCALE

REVISED 5-5-17 CMC  
 SUPERCEDES ALL  
 PREVIOUS VERSIONS

**NSF NOTE:**

ALL FITTINGS AND PARTS MUST COMPLY WITH  
 NSF/ANSI 61 ANNEX G & NSF/ANSI 372

**MT. VIEW - EDGEWOOD WATER COMPANY  
 STANDARD DETAIL IV - 20**

**2" R.P.D.A**

PLACE TWO BANDS  
OF 2" WIDE V92 HIGH  
INTENSITY  
PRISMATIC DOT-C2  
TAPE

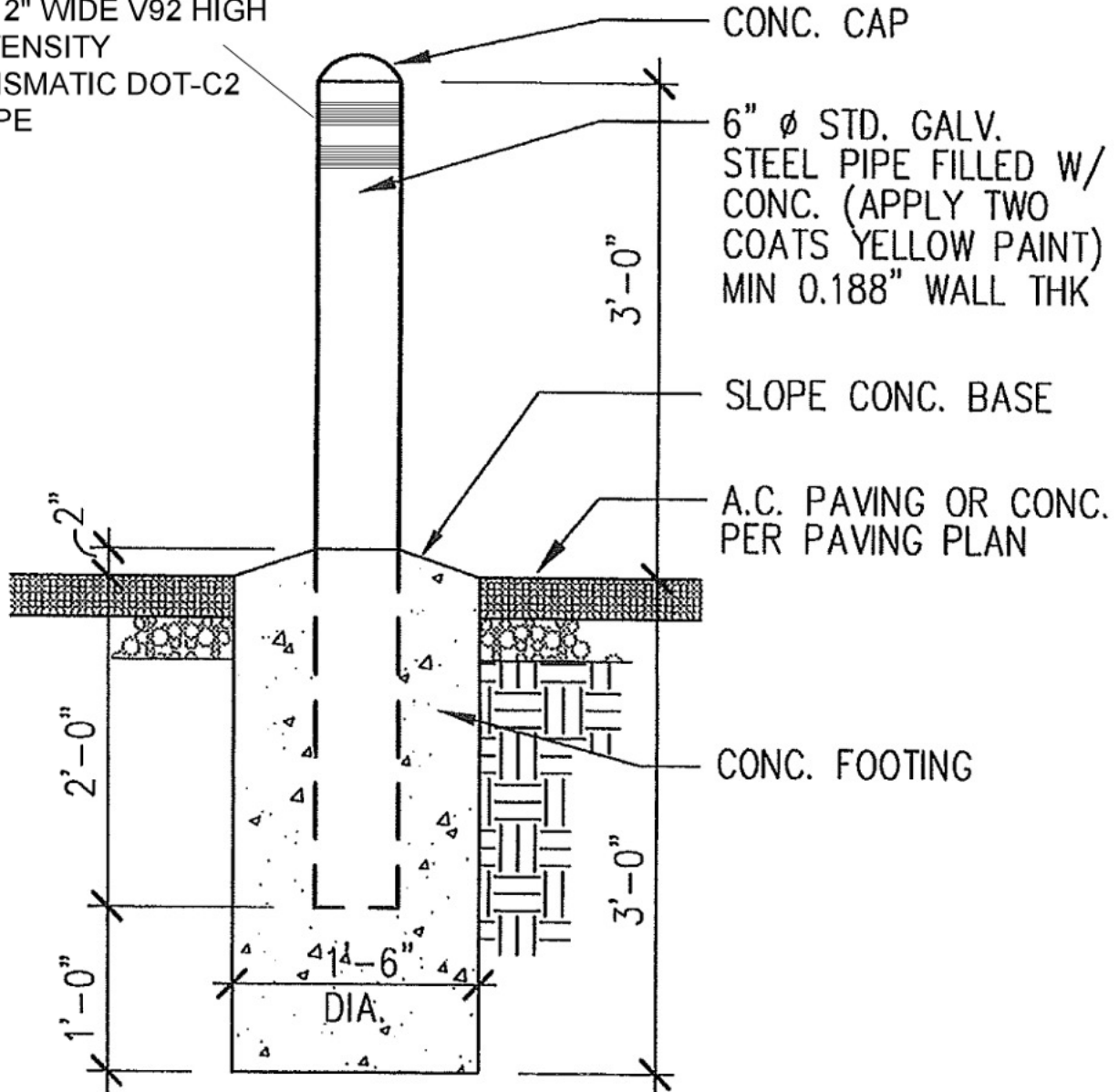

CONC. CAP

6"  $\phi$  STD. GALV.  
STEEL PIPE FILLED W/  
CONC. (APPLY TWO  
COATS YELLOW PAINT)  
MIN 0.188" WALL THK

3'-0"

SLOPE CONC. BASE

A.C. PAVING OR CONC.  
PER PAVING PLAN

2"

2'-0"

1'-0"

1'-6"  
DIA.

CONC. FOOTING

3'-0"

PLACE FOUR BOLLARDS  
OUTSIDE EACH CORNER  
OF THE HYDRANT PAD

MT.VIEW-EDGEWOOD WATER COMPANY  
STANDARD DETAIL IV-21

PIPE BOLLARD

GROUND  
ELEVATION

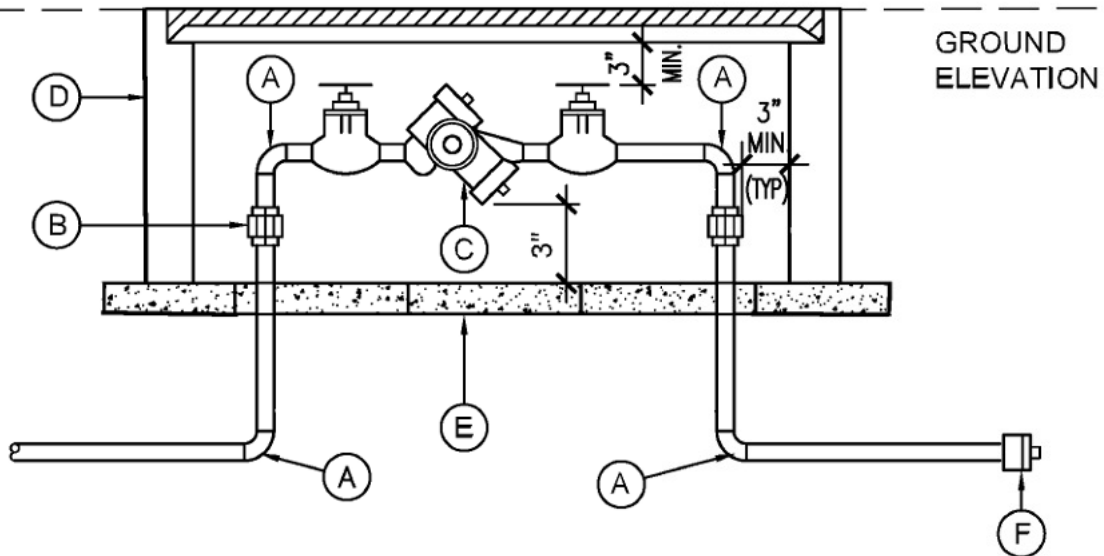

GROUND  
ELEVATION

- (A) BRASS PIPING AS NEEDED
- (B) BRASS UNIONS, MAYBE HORIZONTAL OR VERTICAL, AS NEEDED
- (C) APPROVED D.C.V.A.
- (D) METER BOX SIZED FOR PROPER CLEARANCES

- (E) 2" x 8" x 16" CONCRETE PADS UNDER ENTIRE BOX. FIT AROUND PIPING AS NEEDED AND PLUG MOUSE HOLES.
- (F) CONNECT TO SERVICE LINE

NOTES:

1. THE D.C.V.A. SHALL BE INSTALLED WITH A MINIMUM OF 3.0' CLEAR SPACE ON ALL SIDES TO FACILITATE MAINTENANCE AND TESTING. IT SHALL BE TESTED AFTER INSTALLATION BY A WASHINGTON STATE CERTIFIED BACKFLOW ASSEMBLY TESTER. A PASSED TEST REPORT SHALL BE SUBMITTED TO THE WATER COMPANY PRIOR TO WATER SERVICE.

NSF NOTE:

ALL FITTINGS AND PARTS MUST COMPLY WITH NSF/ANSI 61 ANNEX G & NSF/ANSI 372

MT. VIEW - EDGEWOOD WATER COMPANY  
STANDARD DETAIL IV-22

1-1/2" AND 2" PREMISES  
ISOLATION