

# RVIPro Series - 3.8mm



The RVIPro is lightweight, portable and easy-to-use with 360° articulation and an integrated design. Its waterproof and dustproof 3.5 inch TFT LCD screen and high definition image sensor technology meet IP67 requirements and can take video and pictures.

- Available in Direct View or 90° (Side View)



(1) 902-405-4100



[info@indspek.com](mailto:info@indspek.com)



6289 Quinpool Rd  
Halifax, NS B3L 1A4 Canada



[www.indspek.com](http://www.indspek.com)

## 1 Users Instruction

### 1.1 Use and Application

This product is only for real-time detection and analysis for industrial equipment, casting components, aerospace, oil and gas, inspections etc.

### 1.2 Maintenance and Modification

This product does not have any spare parts for repairs which can be used. Please Call INDSPEK Inc. service at (1)-902 405-4100 for an RMA number to return for evaluation.

### 1.3 Warnings

- When using this product, please observe the following:
- This instrument is prohibited for human and/or animal biological inspection.
- Do not use or store the product in explosive or strong electromagnetic field environments.
- Do not use the product to check objects that are electrified as to avoid electric shock.
- While using, do not touch the end of the lens, particularly after use in high temperature environments, as the end of the lens may cause burns.
- Do not look directly into the LED light source at the end of the lens.
- Do not excessively bend, stretch, twist, or roll the cable.
- After long term use of this product, there is potential for the lens to become dirty, resulting in blurred images and the impact of data collection. Please use alcohol or acetone to clean the objective lens and wait until dry to continue inspection.
- If there is abnormal angle in the articulation operation, stop the current operation, turn off and then contact the supplier.
- Keep the insert tube away from any other liquid besides water, salty water or oil.
- When finished using, clean the front section of the instrument with alcohol or acetone to avoid corrosion.



## 2 Product Specifications

### 2.1 Parameters

|  |  |
|--|--|
| Replaceable Insertion Tube               | Users can easily replace the spare insertion tube  |
| Camera Diameter (mm)                     | 3.8mm  |
| Camera Material                          | Titanium alloy   |
| Camera Pixel                             | 300,000  |
| Depth of Field                           | Standard: 5mm ~ 80mm   |
| Field of View                            | 85°  |
| Image Magnification                      | 4X   |
| Light Control                            | 7 levels   |
| Bright/Chroma/ Contrast Ratio Adjustment | 0-16 levels  |
| White Balance                            | Auto white balance   |
| Articulation Control                     | 360 ° all-way mechanical control/4-way articulation  |
| Bending Angle                            | ≥160°  |
| Effective Working Length                 | 1.5m/3.0m  |
| Insertion Tube                           | Quadruple tungsten-braided tubes   |
| Protecting Device of Durability          | Buffer protection device between the host and wear-resistant tube  |
| Language                                 | English, French, Spanish, German, Russian, Dutch, Italian, Chinese, Japanese and Korean, etc. (12)       |
| Display                                  | Highlight 3.5 inches TFT LCD   |
| Display Resolution                       | 640/480  |
| Image/Video Format                       | JPEG/AVI   |
| Host Structure                           | Handheld Design  |
| Memory                                   | Standard SD card:8G, Maximum: 32G  |
| Data I/O port                            | Micro-USB port, HDMI output port   |
| Probe articulation control               | The speed of the probe articulation is controlled by rocker. Release the rocker to complete positioning. |
| Waterproof                               | Camera/Object glass/Tubes:IP67   |
| Host Working Time                        | ≥4.5 hours   |
| Weight                                   | ≤0.45kg/0.99lbs (with batteries)   |
| Power Supply                             | Rechargeable lithium battery (removable)/ Direct power supply  |
| Battery Capacity                         | 4.2V,3200mAh   |
| Power Consumption                        | 3W   |
| Charging Parameters                      | DC5V, Maximum current:1A   |

Host System Working Temperature:

-10°C ~ 50°C, when below 0°C, the display needs preheating.

Camera Working Temperature:

-20°C ~ 85°C, when below 0°C, please reduce oriented operation.

Store Temperature

-20°C ~ 60°C

Relative Humidity

Maximum: 90%, non-condensing

## 3 Operations

### 3.1 Removing the Instrument

Open instrument box, and while taking out the unit, set aside and pay close attention to the probe. Avoid hitting the probe and scratching probe lens.

### 3.2 Prior to Operating

Check whether the insertion tube is fully inserted and the locking nut is tight.  
Insert SD card.

### 3.3 Insert the Tube/Probe

Gently put the endoscope insertion tube into the handheld device.

### 3.4 Adjust Brightness

Adjust the brightness of the light source to obtain the appropriate level of illumination.

### 3.5 Articulation

Depending on the inspection, operate the joystick control to articulate the end of the probe.

1. If joystick suddenly meets tension or resistance, immediately stop using, return the joystick to the middle position and remove the probe carefully.
2. Slowly operate the joystick.

## 3.6 Remove Insertion Tube

Place the insertion tube in a straight position length wise.  
Ensure joystick is in the middle position and then carefully disconnect.







## 3.7 Power Off

Turn off the power switch, put the scope into the instrument box and place the insertion tube into the tube well.

# 4 Operation Guide

## 4.1 Working Modes

1. Real time detection mode
2. Playback mode
3. System settings mode. When turning on, it begins in “real time detection mode.”  
Details of the various modes and the key functions, please refer to the table below, “Button Function List.”

| Buttons   | Name                   | Real Time<br>Direction Mode                               | Play Back<br>Mode | Video<br>Play | System<br>Setting | Time<br>Settings |
|---|------------------------|---|-------------------|---------------|-------------------|------------------|
|  | On/Off                 | Real Time<br>Direction                                    |                   |               | —                 |                  |
|  | Up                     | —   | Up                | —             | Up                | Up               |
|  | Return/<br>Playback    | Photo/Video<br>Playback                                   | Return            | Exit          | Return            | Exit             |
|  | Menu/OK                | Enter into Menu   | —                 | —             | OK                | OK               |
|  | Down/Switch<br>Photo   | Switch<br>Photo & Video                                   | Down              | —             | Down              | Down             |
|  | LED<br>Brightness      | Adjust Brightness   |                   |               |                   |                  |
|  | Joystick<br>Controller | Control the direction of probe : up / down / left / right |                   |               |                   |                  |

## • Real Time Detection Mode:

Under this mode, users can see real-time image taken by the probe; control the probe movement and speed by joystick, lock the position as well as adjust the LED light. Press  button to select photo or video mode.

## • Playback Mode:

Press  “playback” to view images of JPG files and playback recorded video of AVI files.

When in video mode, press this button, the system will enter the video playback mode.

## • System Setting Mode:

In “real time detection mode”,  press this will enter system setting mode and set the parameter of the image and system.

## 5 Connect with PC & Read the Data of SD Card

### Method 1: Read the data directly from your PC

5.1 Remove SD card and insert into the USB card reader.

5.2 Click “my computer” to find the removable disk.

### Method 2: Connect with PC by USB line.

5.3 If it is the first time to connect RVIPro with PC by USB, it needs to be automatically installed with USB drivers. When the two are connected successfully, RVIPro will enter the PC read mode. Then you can read the data in SD card like Method 1.

5.4 When the RVIPro is in USB mode, please do not pull out the SD card. It will lead to an error.

## 6 USB Connection

The USB port is used for recharging or connecting with a PC. When it is connected with a PC, the RVIPro screen will display “memory”, “camera” or “charging” options for users to choose:

1. Selecting “memory”, the PC only has card reader (SD card) function.
2. Selecting “camera”, with the camera connected into PC, the RVIPro display interface will be transferred to the PC end. Video and other video features can be achieved through remote observation of the Internet.
3. Selecting “charging” to enter charge mode.

## 7 System Setting

In the “real-time detection mode”, press  will enter “system setting” mode.

### 7.1 Playback

In system settings menu, you can select the playback of photos or video playback.

### 7.2 Language setting

12 Languages: English, French, Spanish, German, Russian, Dutch, Italian, Chinese, Japanese and Korean, etc.

### 7.3 Date/Time

Users can set the system display time.

### 7.4 Standby time setting

Users can set the standby time, in order to reduce power consumption.

### 7.5 Auto power off

User can set the auto power off time.

### 7.6 Continuous shooting

According to different needs, users can set single shooting, continuous shot or triple shot mode.

### 7.7 Recording time

Users can set the recording time.

### 7.8 Format

When entering into the format interface, if you press “Yes”, all the data in the SD card will be deleted. Be sure to back up any data you wish to keep.

### 7.9 TV mode

TV mode setting.

### 7.10 Image rotation

Image rotation of 180° setting.

### 7.11 Color adjustment

After entering the color setting interface, the brightness, chroma and contrast can be adjusted.

### 7.12 Factory default setting

Pressing this button will clear the user settings, and restore to the factory default settings.

### 7.13 Version

It shows the current system version in the version setting.

## 8 Powering Off

During normal operation, hold On/Off button for 1 to 2 seconds, to power off. It needs to store some system parameters and the image data, which takes a few seconds to finish the power off operation.

## 9 Replace The Insertion Tube

### Part 1: Inserting Replacement Head

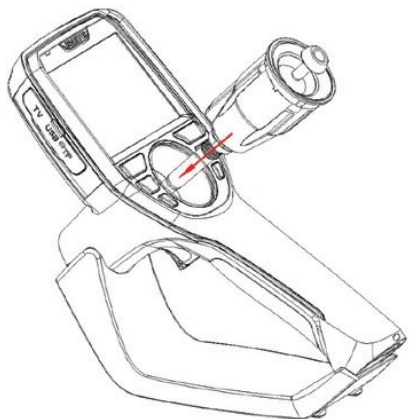

**Step 1:** Insert replacement Tube through the front side of scope.



**Step 2:** Align the triangle located on the replacement Tube at top center

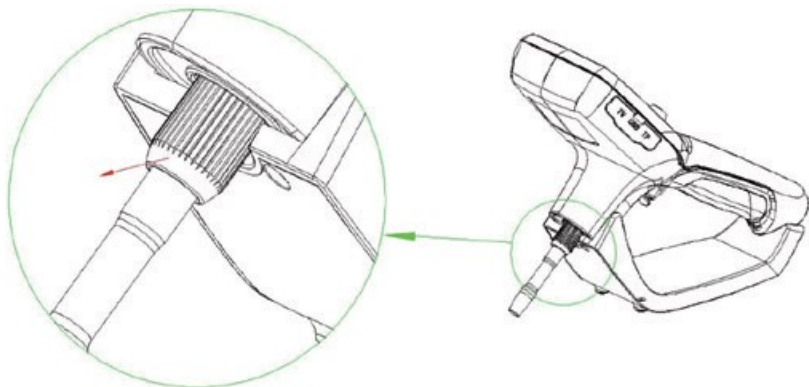

**Step 3:** After replacement Tube is inserted and aligned, tighten the locking nut on the back side of probe.



# Operation Manual

## Part 2: Removing Replacement Insertion Tube

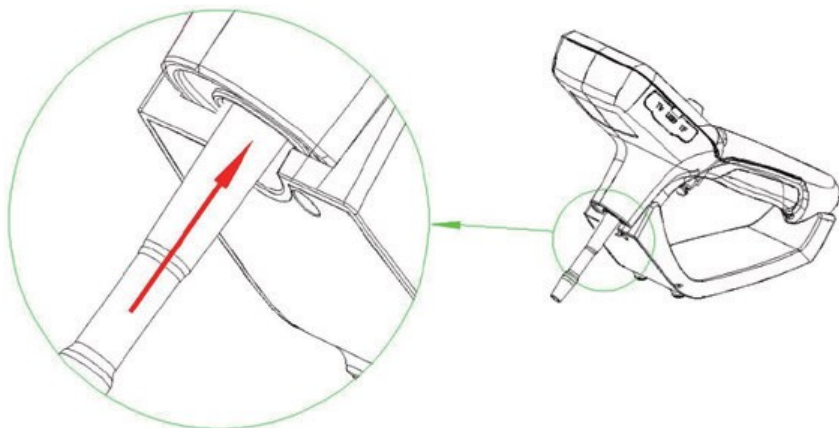

**Step 1:** Remove locking nut from the back side of the replacement Tube.

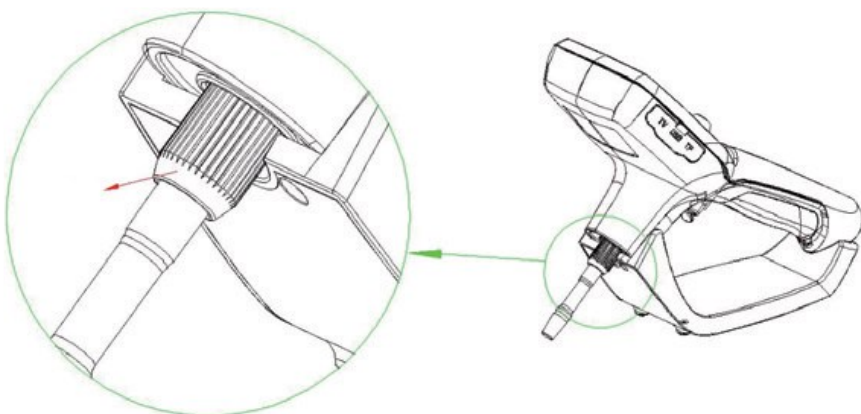

**Step 2:** Push the rubber sleeve upwards to remove replacement Tube.

### Standard Configuration:

Instrument Case, RVIPro, battery, card reader, 8G SD card, adaptor, USB line, manual.

### Optional:

Detachable magnetic base, battery, insertion tube, and digital battery charger.

## 10 Instrument Storage

- Keep the instrument at room temperature, keep it clean, dry and avoid large impacts.
- It is prohibited to store the instrument in high temperature, high humidity, strong light, strong shock, high dust, polluted or corrosive environments.
- Do not store the instrument with other objects.
- When the product is not in use for a long periods, take out the battery and regularly check the operation of the instrument.

## 11 Solutions to Common Problems

| Problem                               | Reason   | Solution   |
|---------------------------------------|--|--|
| Boot without reaction                 | No Battery or Power Shortage                     | Charge or Install Battery                                |
| Auto Shutdown                         | Battery Power Shortage                           | Charge or Change Battery                                 |
| Boot Screen Freezing                  | System Boot Failure<br>Or Battery Power Shortage | Remove the Battery to<br>Reinstall and Restart or Charge |
| Image can not be recorded<br>or Found | The SD card<br>has not Enough Memory             | Replace SD card or<br>Delete unwanted files              |



(1) 902-405-4100



6289 Quinpool Rd  
Halifax, NS B3L 1A4 Canada



info@indspek.com



www.indspek.com