

F/A-18

A+/B/CF-188

F/A-18A+/B/CF-188

ROYAL CANADIAN AIR FORCE, ROYAL AUSTRALIAN AIR FORCE & SPANISH AIR FORCE
 F/A-18A+/B/CF-188 ホーネット / オーストラリア空軍 / スペイン空軍 / カナダ空軍



F/A-18A+/B/CF-188

F/A-18 is a twin-engine supersonic, all-weather carrier-capable multirole fighter jet, designed to dogfight and attack ground targets.

Canada was the first export customer for the Hornet, replacing the CF-104 Starfighter, the CF-101 Voodoo and the CF-116 Freedom Fighter. The Canadian Forces Air Command ordered 98 A models (CF-188A/CF-18A) and 40 B models (CF-188B/CF-18B). The original CF-18 as delivered is largely identical to the F/A-18A and B models.

In 1991, Canada committed 26 CF-18s to the Gulf War, based in Qatar. These aircraft primarily provided Combat Air Patrol duties, and later to perform air strikes on Iraqi ground targets. In 1999, 18 CF-18s were deployed to Aviano AB, Italy, where they participated in both the air-to-ground and air-to-air roles in the former Yugoslavia.

The Royal Australian Air Force purchased 57 F/A-18A fighters and 18 F/A-18B two-seat trainers to replace its Mirage IIIOs. Original differences between the Australian and US Navy's standard F/A-18 were the removed nose wheel tie bar for catapult, addition of a high frequency radio, an Australian fatigue data analysis system, an improved video and voice recorder, and the use of ILS/VOR.

F/A-18 deliveries to the RAAF began in 1984, Australia deployed 4 aircraft to Diego Garcia, in an air defense role, during coalition operations against the Taliban in Afghanistan. In 2003, 75 Squadron deployed 14 F/A-18s to Qatar as part of Operation Falconer.

The Spanish Air Force ordered 60 EF-18A model and 12 EF-18B model Hornets. Delivery of the Spanish version started in 1985. These fighters were upgraded to F-18A/B+ standard, close to F/A-18C/D.

Spanish Air Force EF-18 Hornets have flown Ground Attack, SEAD, combat air patrol (CAP) combat missions in Bosnia and Kosovo, under NATO command, in Aviano detachment.

CAUTION

- *Read carefully and fully understand the instructions before commencing assembly.
- *Keep out of reach of children. Children must not be allowed to put any parts in their mouths, or pull plastic bag over their heads.
- *When using adhesives and paints, please make sure not to use them in closed room or near the fire.
- *When assembling this kit, tools including knives are used. Extra care should be taken to avoid injury.

WARNING: CONTAIN SMALL PARTS NOT FOR CHILDREN UNDER 14 YEARS OF AGE.

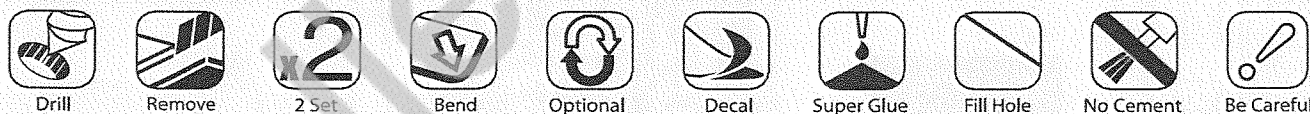

TOOLS RECOMMENDED

Cement	Side Cutter	Modeling Knife	
		Tweezers	

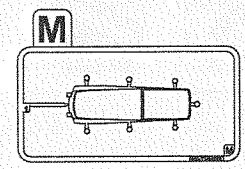
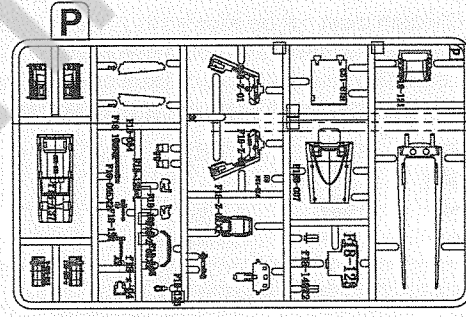
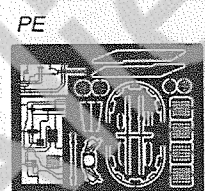
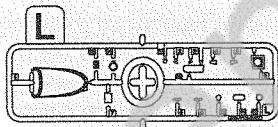
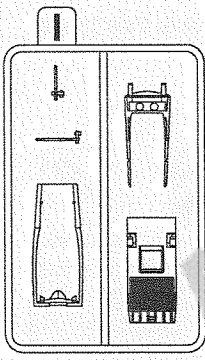
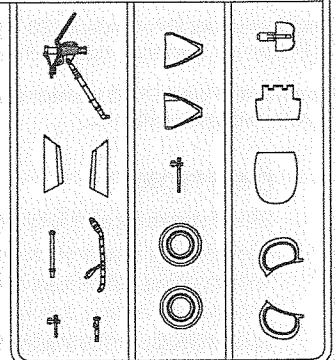
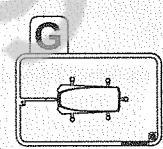
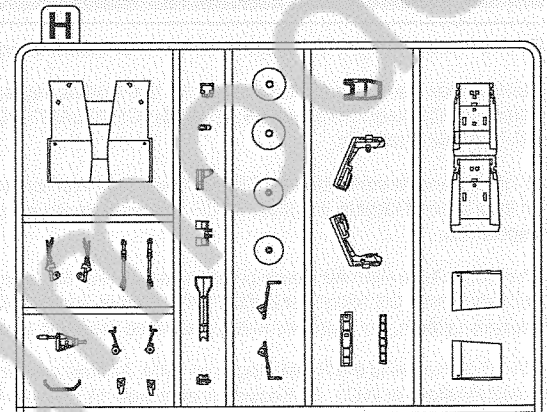
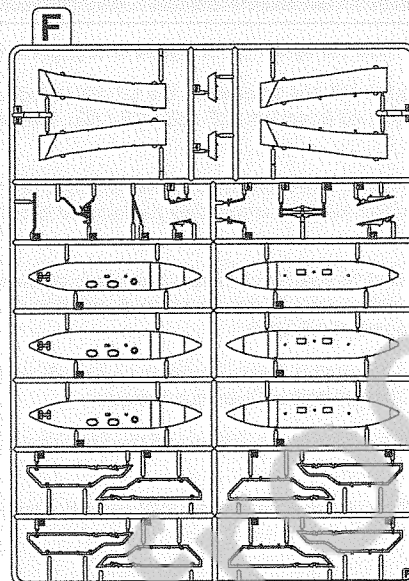
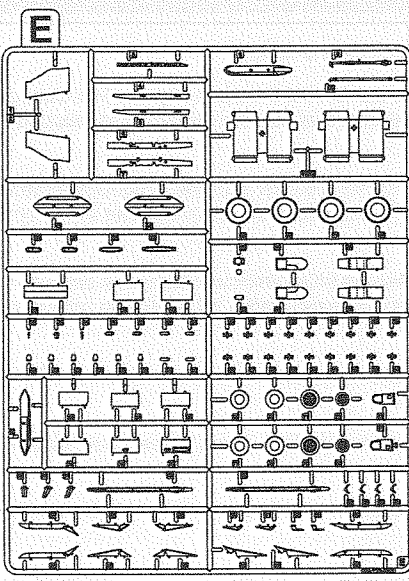
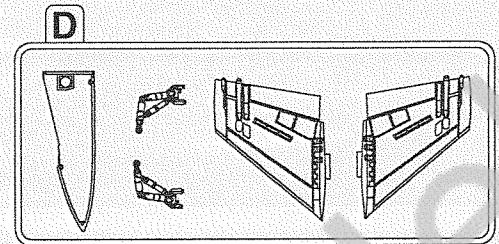
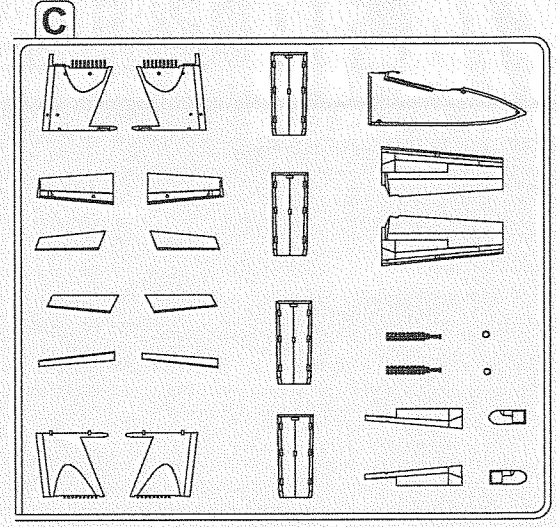
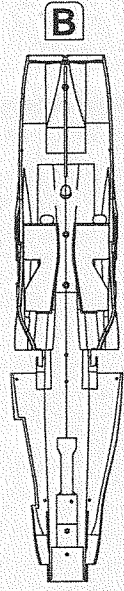
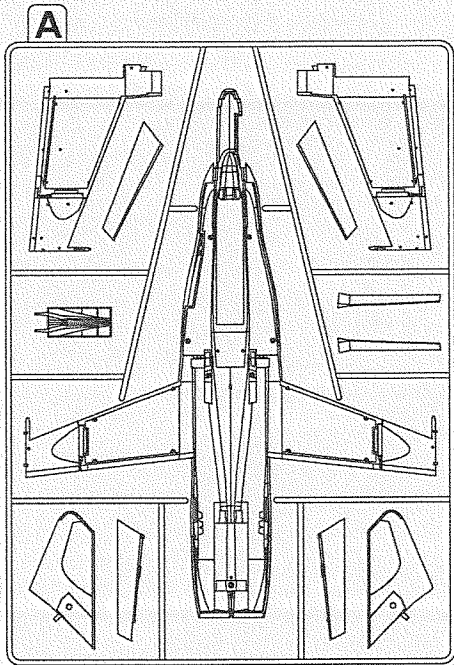

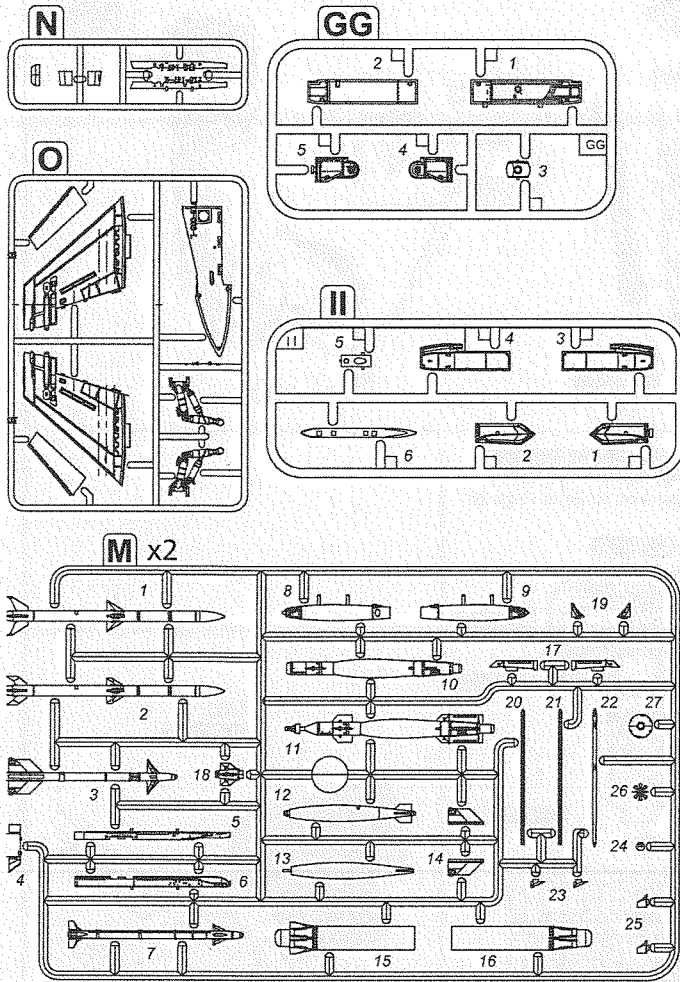

AFTERMARKET SERVICES CARD

When requesting replacement parts, please take or send this form to your local dealer so that the parts required can be correctly identified. Please note that specifications and availability are subject to change without notice.

or visit <http://www.kineticmodel.com> for latest information.

For more information, please contact services@kineticmodel.com

Part Code	K48030	Item	Qty
00-100-021	WEAPON SET (AIM-9x9M,120B/C,GBU-12) PARTS M	M	2
00-100-030	LARTIN POD PARTS GG	GG	1
00-100-032	SNIPER XR POD PARTS II	II	1
00-112-001	1/48 F/A-18 UPPER FUESLAGE A	A	1
00-112-002	1/48 F/A-18 LOWER FUESLAGE B	B	1
00-112-003	1/48 F/A-18 FLAPS C	C	1
00-112-004	1/48 F/A-18 C/D VERTICAL TAIL D	D	1
00-112-005	1/48 F/A-18 WHEEL, PYLONS E	E	1
00-112-006	1/48 F/A-18 FUEL TANKS, PYLON F	F	1
00-112-007	1/48 F/A-18 A/C CANOPY G	G	1
00-112-008	1/48 F/A-18 COCKPIT, LANDING GEAR H	H	1
00-112-009	1/48 F/A-18 A/C PARTS I	I	1
00-112-012	1/48 F/A-18 COMMON CLEAR PARTS L	L	1
00-112-013	1/48 F/A-18 DOUBLE CANOPY M	M	1
00-112-014	1/48 F/A-18 A/B/C/D PYLON ANN. PART N	N	1
00-112-015	1/48 F/A-18 A/B VERTICAL TAIL PART O	O	1
00-112-016	1/48 F/A-18 B/D PARTS P	P	1
01-112-48030	1/48 F/A-18A/B+		1
03-112-48030	1/48 F/A-18A/B+ MANUAL		1
06-112-48031	1/48 F/A-18A/C	PE	1

The Making of Kinetic Hornet model kit

The 1/48 Hornet kit project cannot be realized without the help from Rick Chin, a well-respected modeler and the owner of Uncle Bill's Hobby in Calgary, Canada. We are so proud to have Rick involved in this project, and so we got the accurate information and numerous photos which enable us made an updated and accurate model possible. With him, we had the tremendous support from Cold Lake ROCAF to ensure us to make an accurate CF-188 model kit as most updated configurations are not known in most documents and online. We are sad that Rick left us in April 2014 and we know he would like all of us enjoy building this model. Besides, we would like to thank you all the contributors, they are Thomas Sime, the commander at that time call sign "Sleepy" and our GIB team.

In memory of our old good friend, we hereby to let everyone knows the "hero" behind the project, which was started in 2008. Thank you, Rick.



CAUTION: There is a small decal update in the box loose. It is very small, secure this small sheet before anything else!

In my opinion, this kit is so versatile to create a current Canadian Hornet or early version with much better accuracy than any other kit released to date. A few small mods, via scratch build or aftermarket, you can create a great replica. Thank you for all that were involved in the release of this kit.

Hi Rick, your hornet is here! We deliver it finally!

Ejection Seat cover required for aircraft on static display.

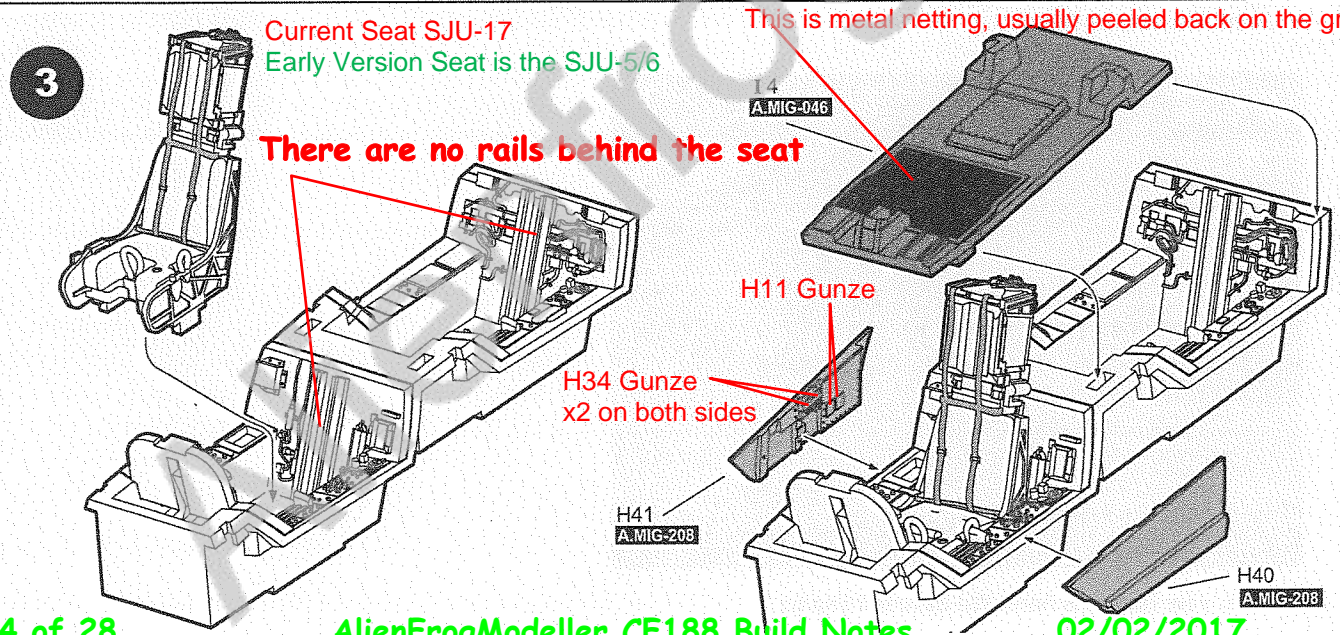
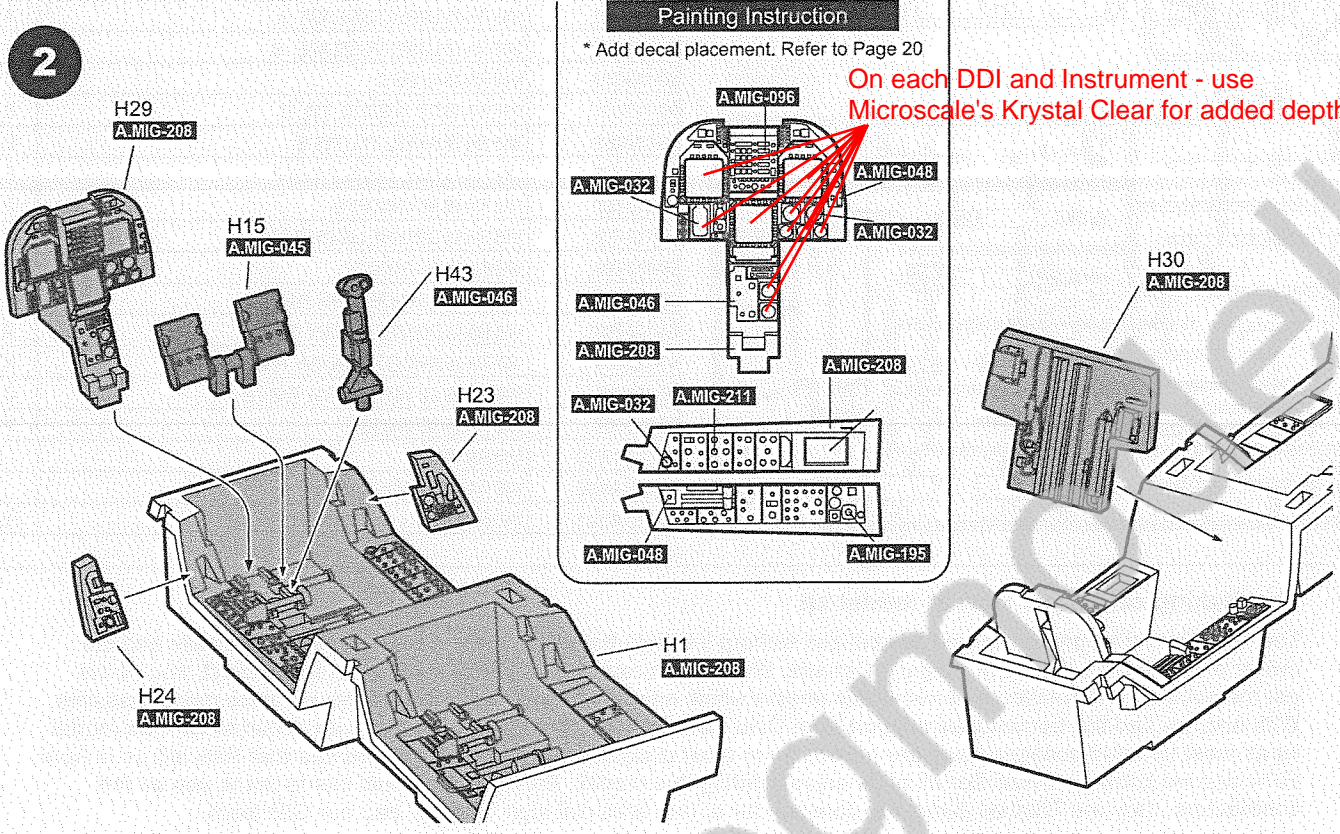
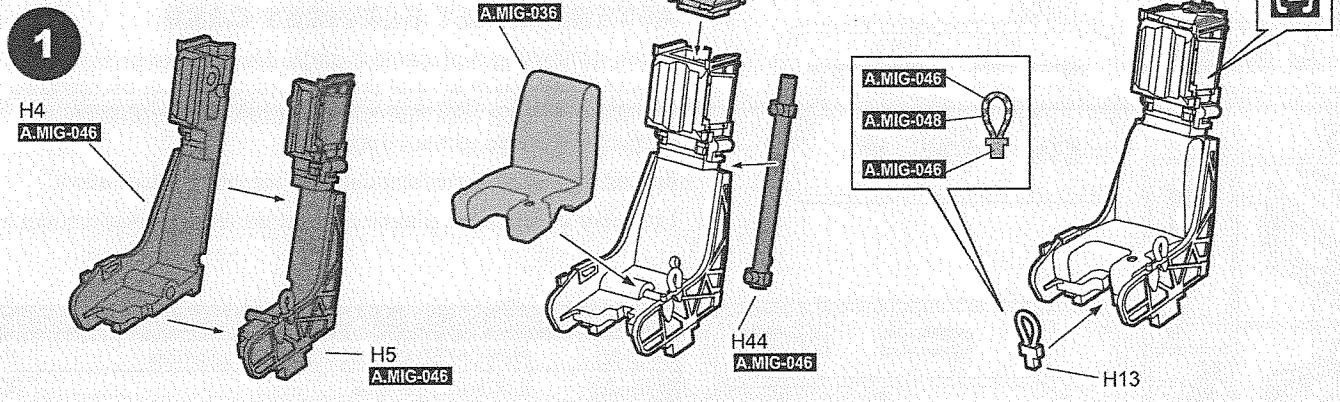

4

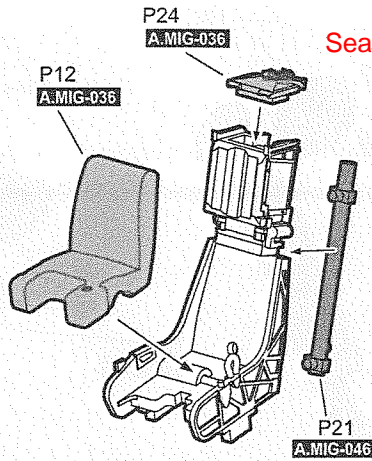
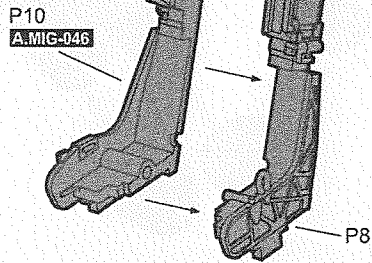

Seat Cover reqd when on static display

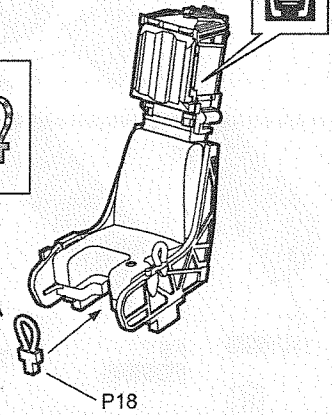
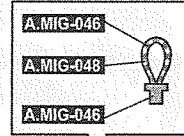

There is only ONE seat harness on the PE Sheet.

5

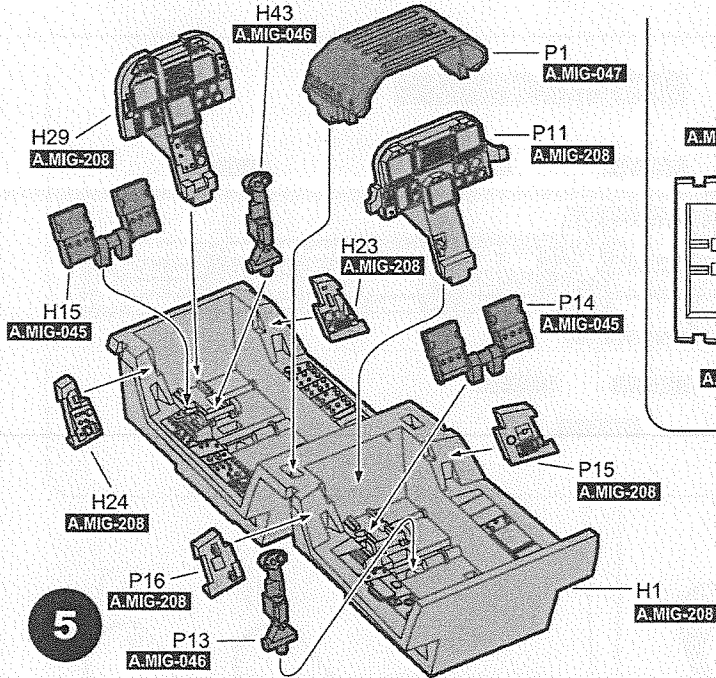

Painting Instruction

* Add decal placement. Refer to Page 20

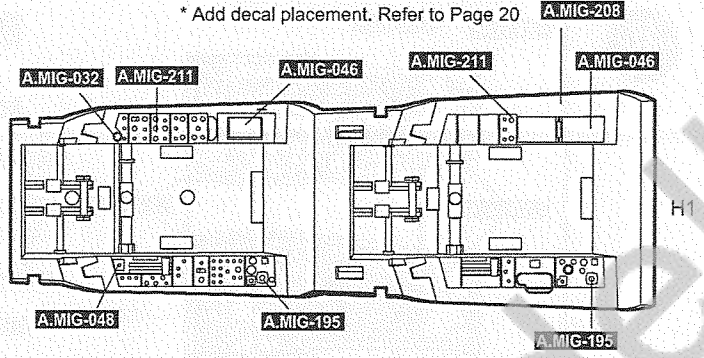

Painting Instruction

* Add decal placement. Refer to Page 20

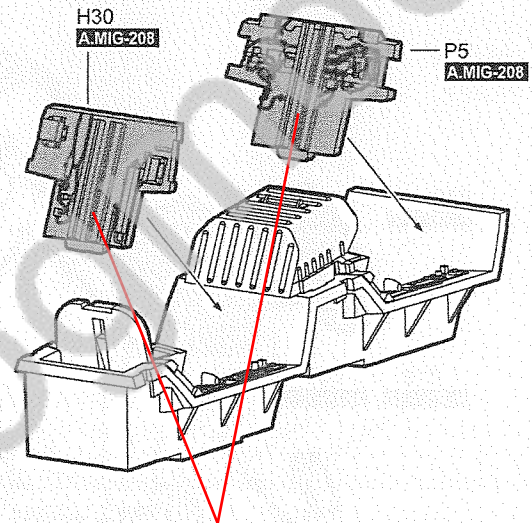
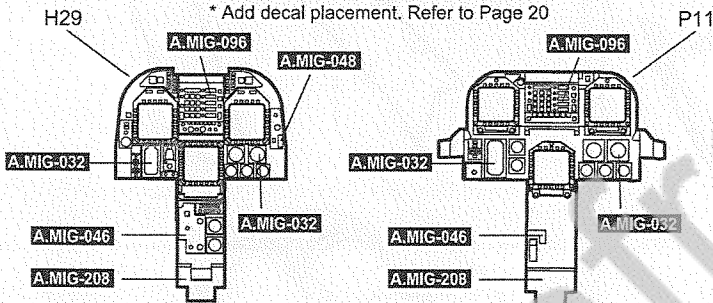

These rails don't exist - check for fit if you remove

6

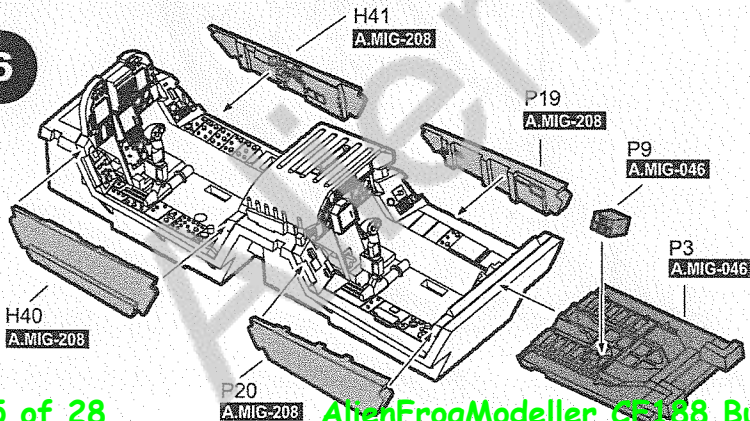

4

1

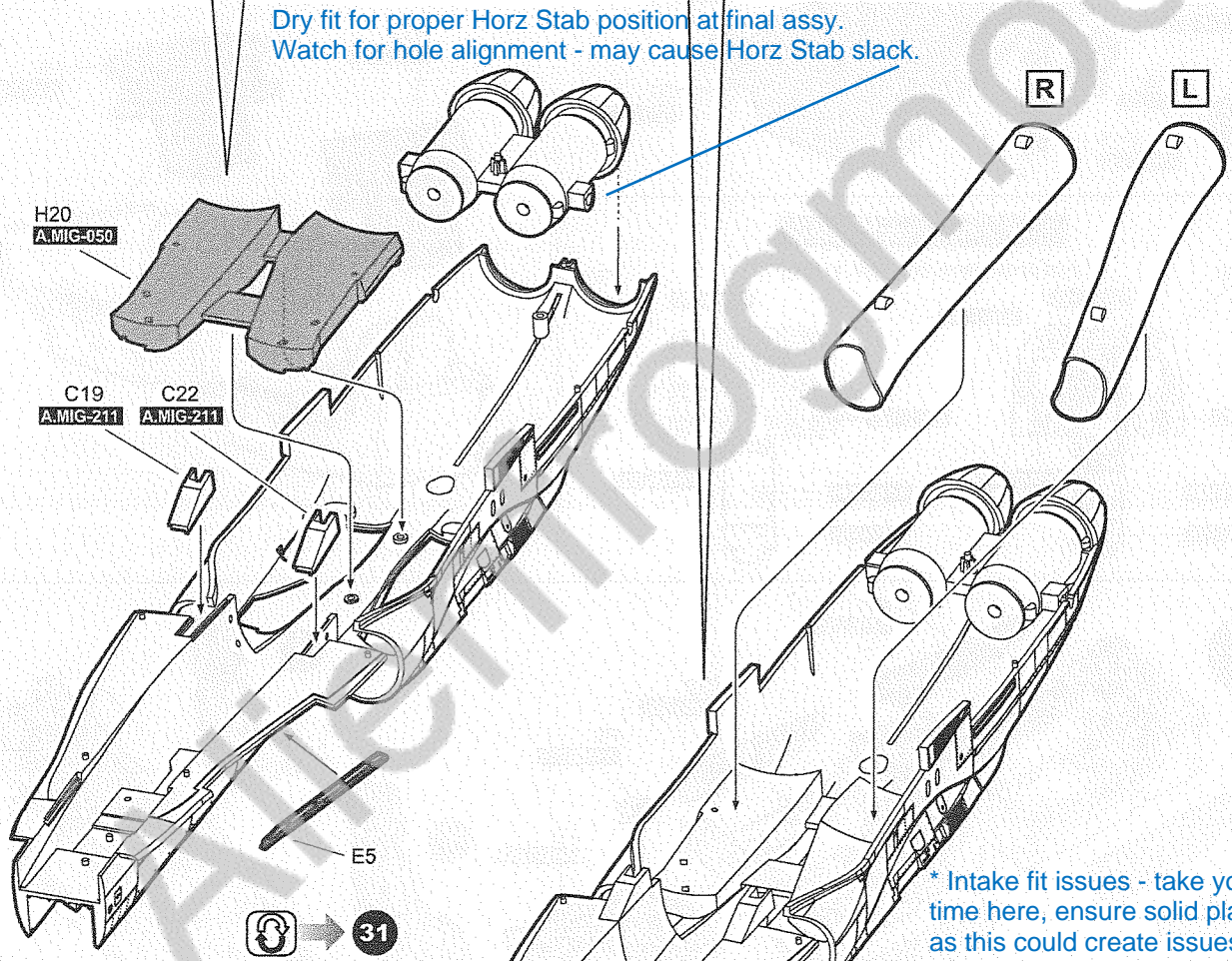
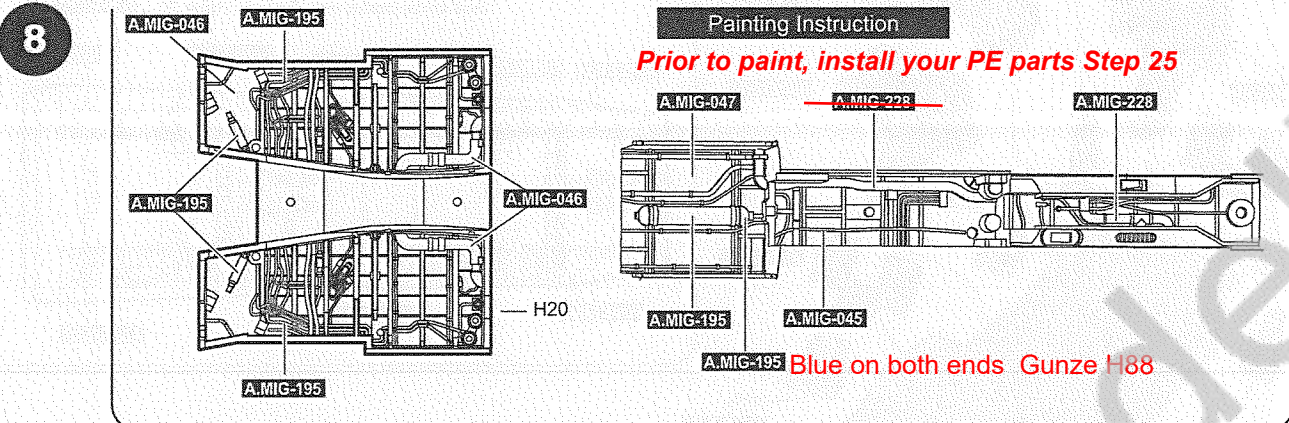
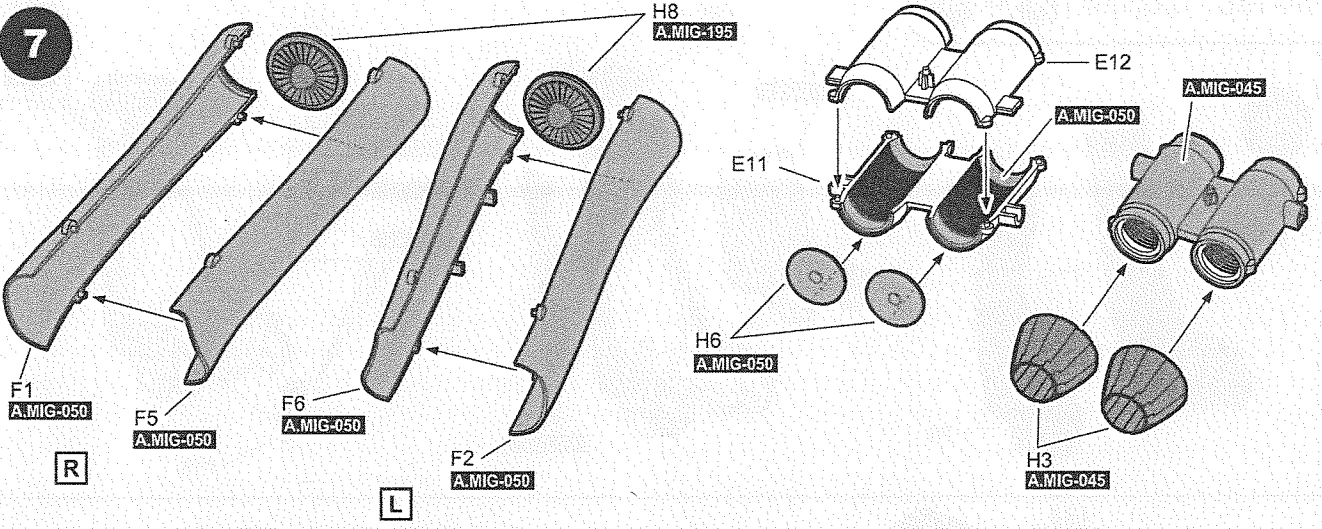

9 Refuelling Probe Open H13 Gunze - no primer  Refuelling Probe Close

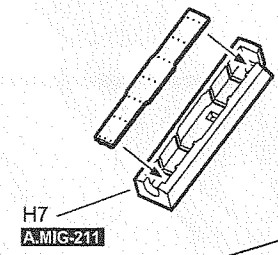
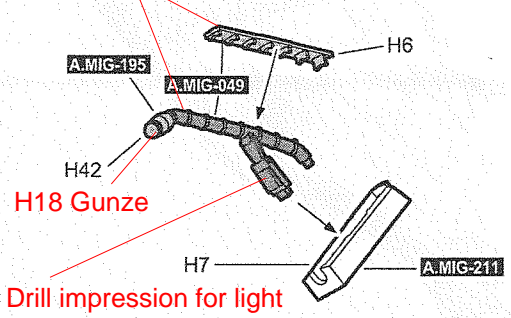

Do Not glue into place until you dry fit with lower fuselage and upper fuselage is complete.

AOA Vane installed, place Blue Tack over to save during building

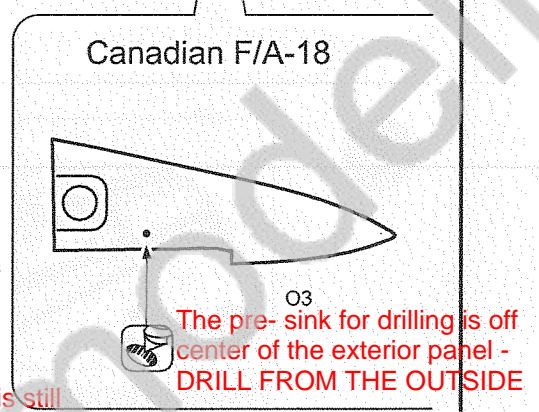
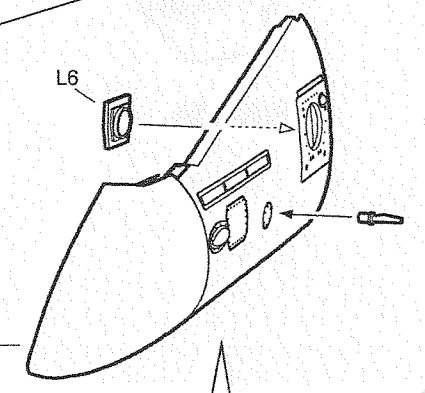
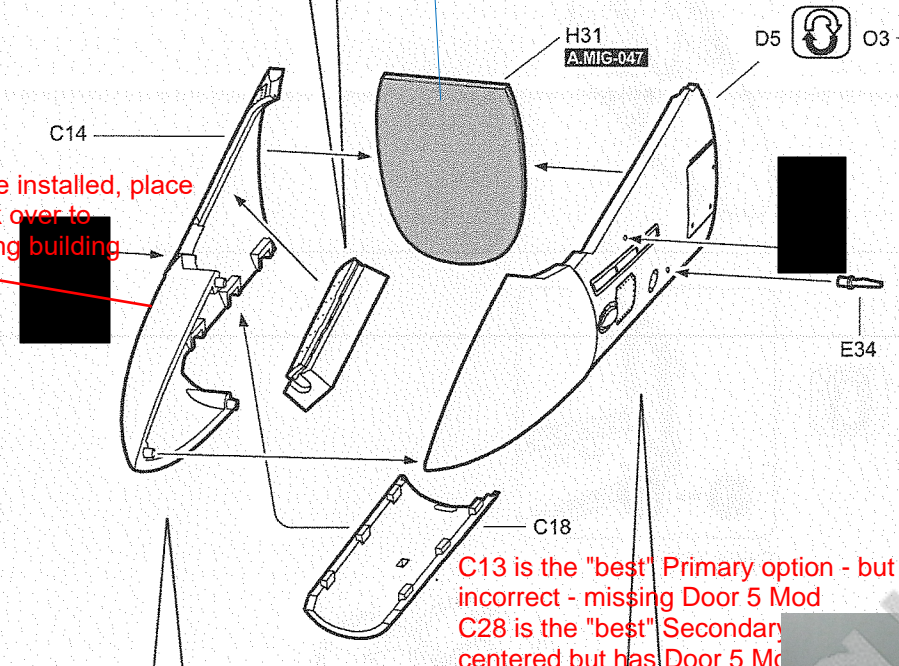

C13 is the "best" Primary option - but is still incorrect - missing Door 5 Mod
C28 is the "best" Secondary centered but has Door 5 Mo

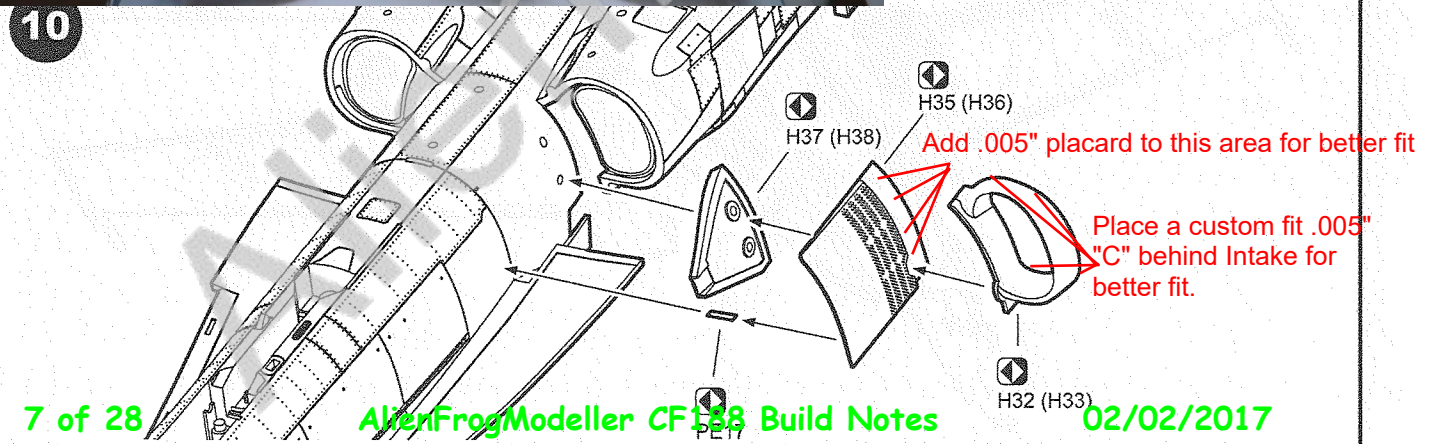
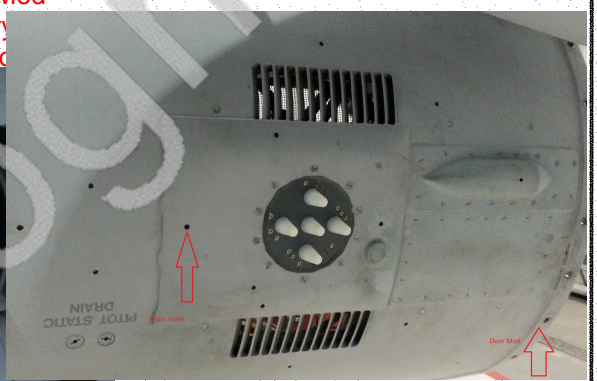

11

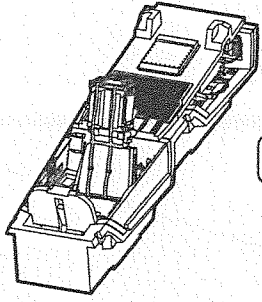

F/A-18A
Sports car version

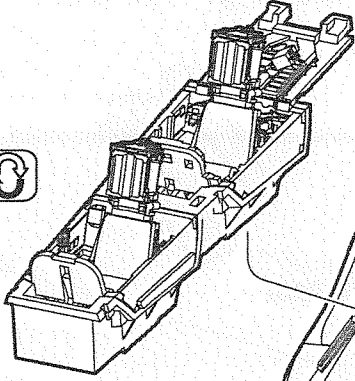

F/A-18B
Family Version

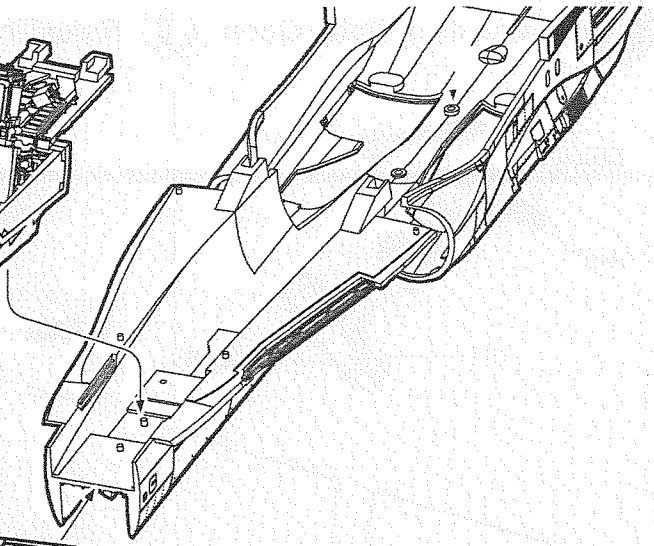

Fit issues can occur here, dry fit many times with the upper fuselage to ensure correct alignment.

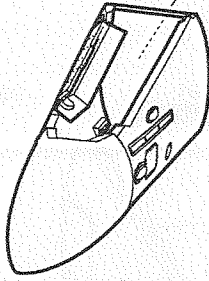

12

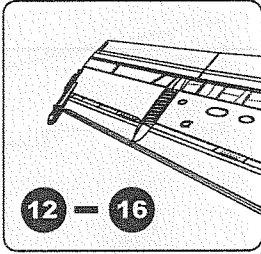

Wings extended

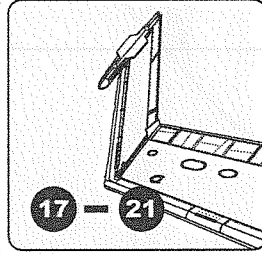

Fold Wings

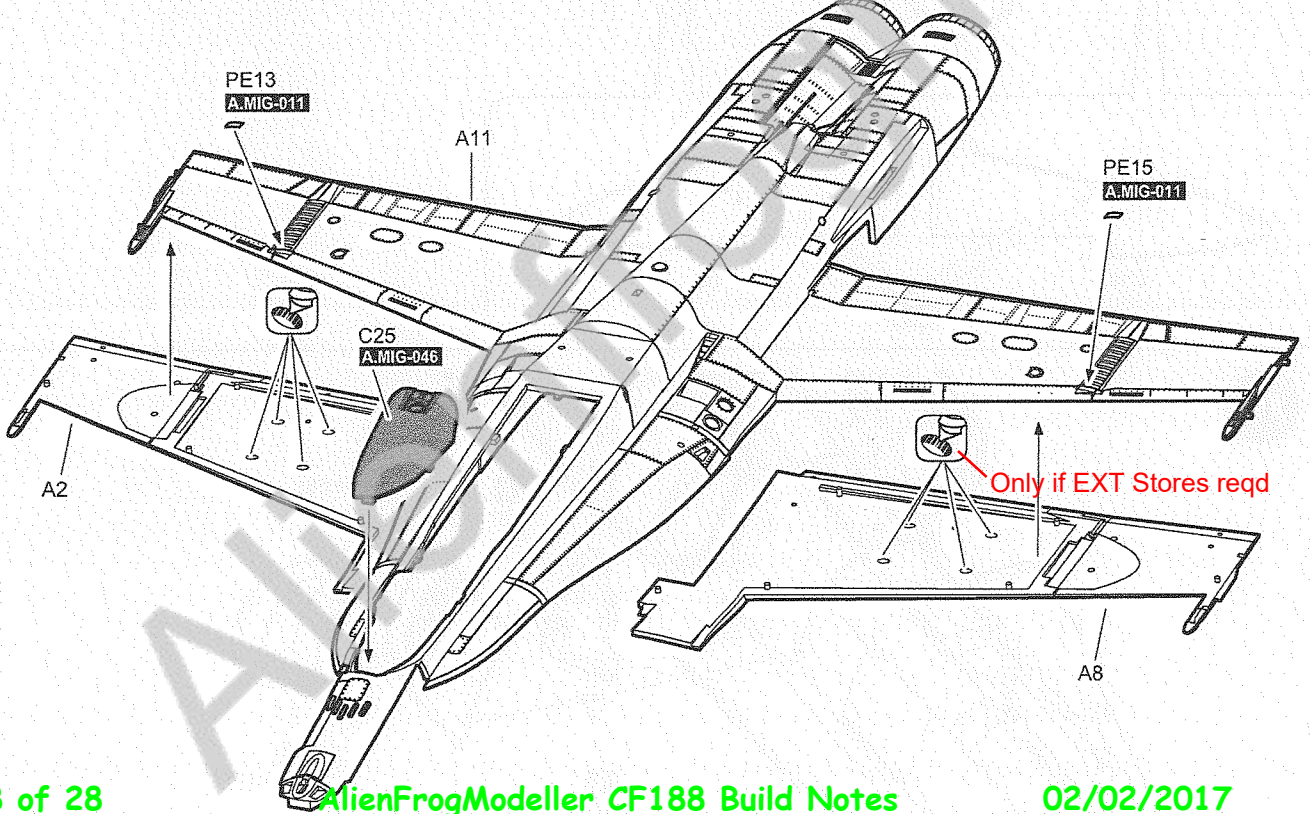
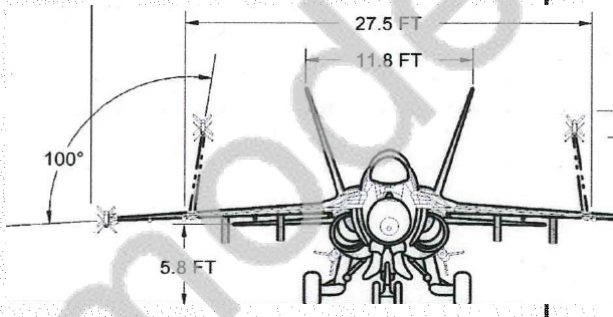

13

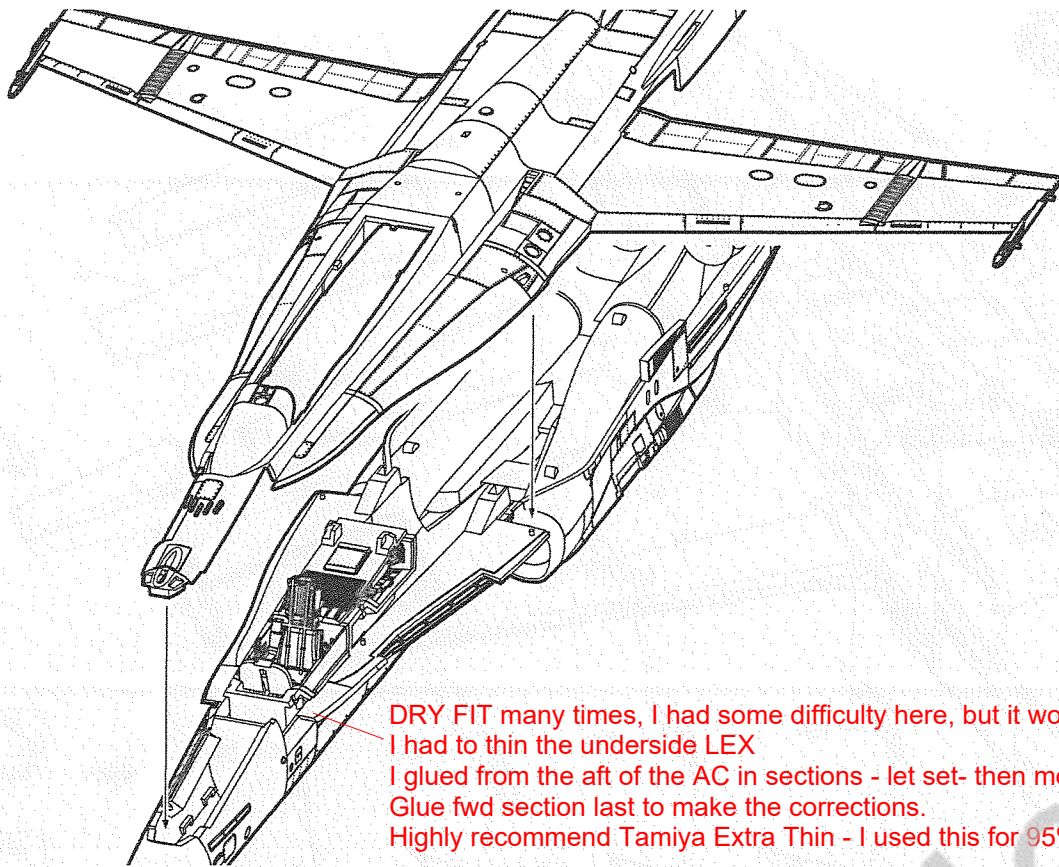

DRY FIT many times, I had some difficulty here, but it worked out okay.
 I had to thin the underside LEX
 I glued from the aft of the AC in sections - let set- then move fwd for ease
 Glue fwd section last to make the corrections.
 Highly recommend Tamiya Extra Thin - I used this for 95% of the build.

14

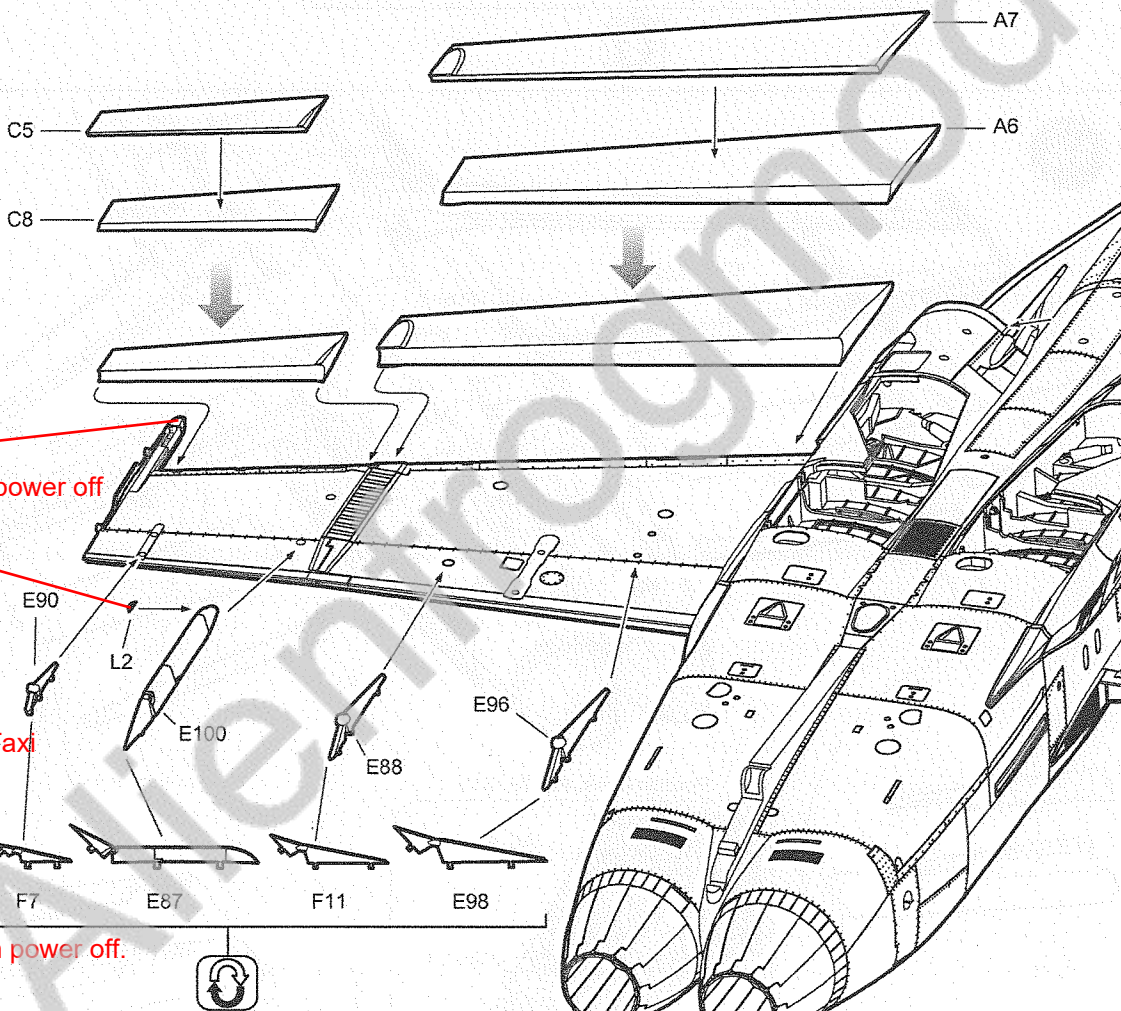

15

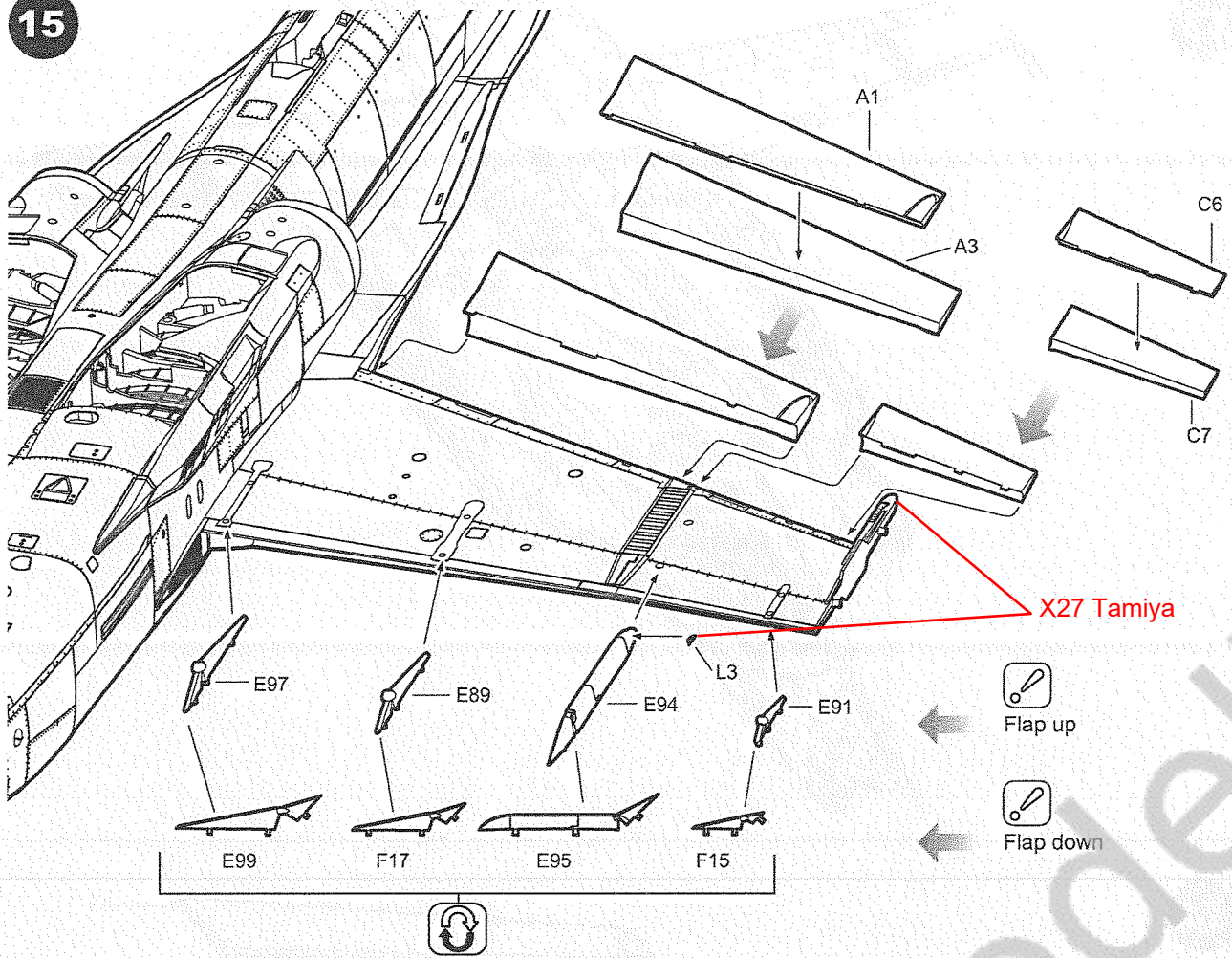

16

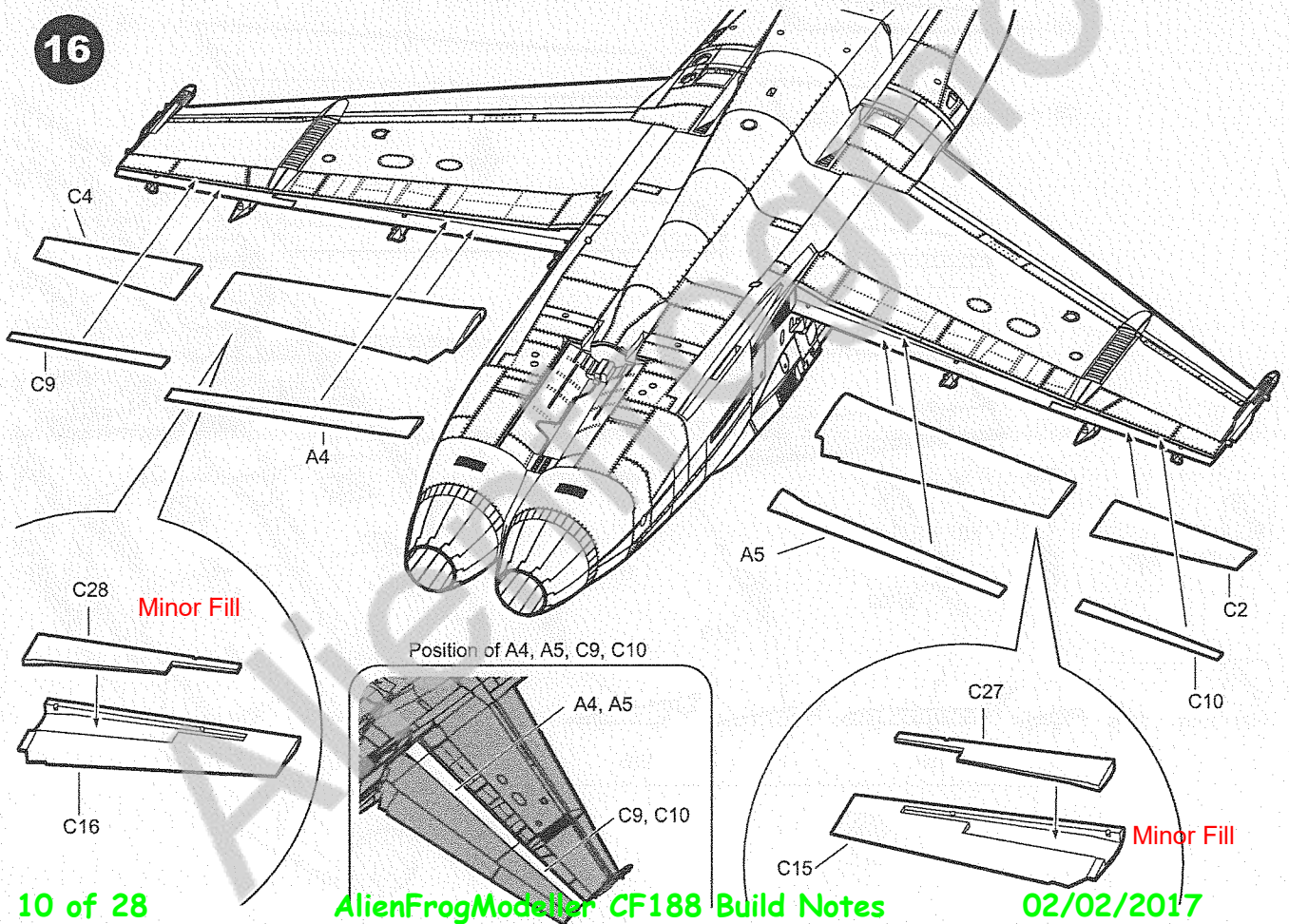

17

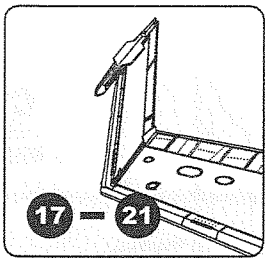

Fold Wings

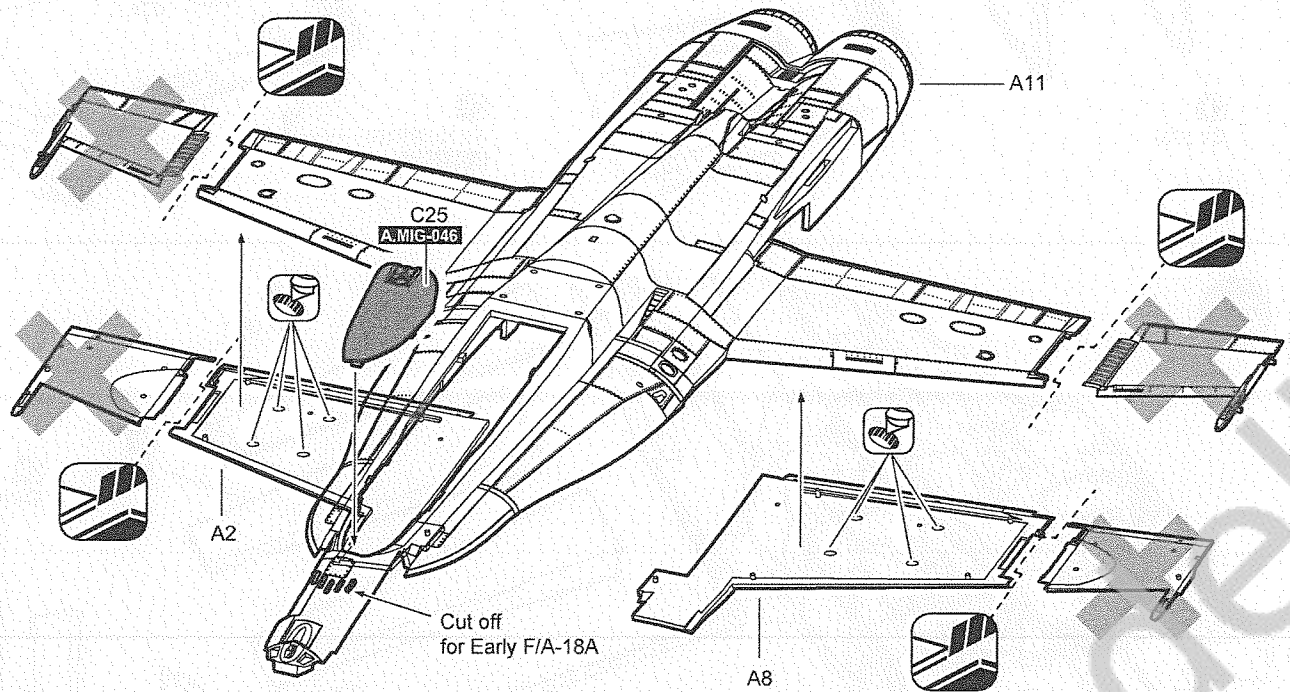

18

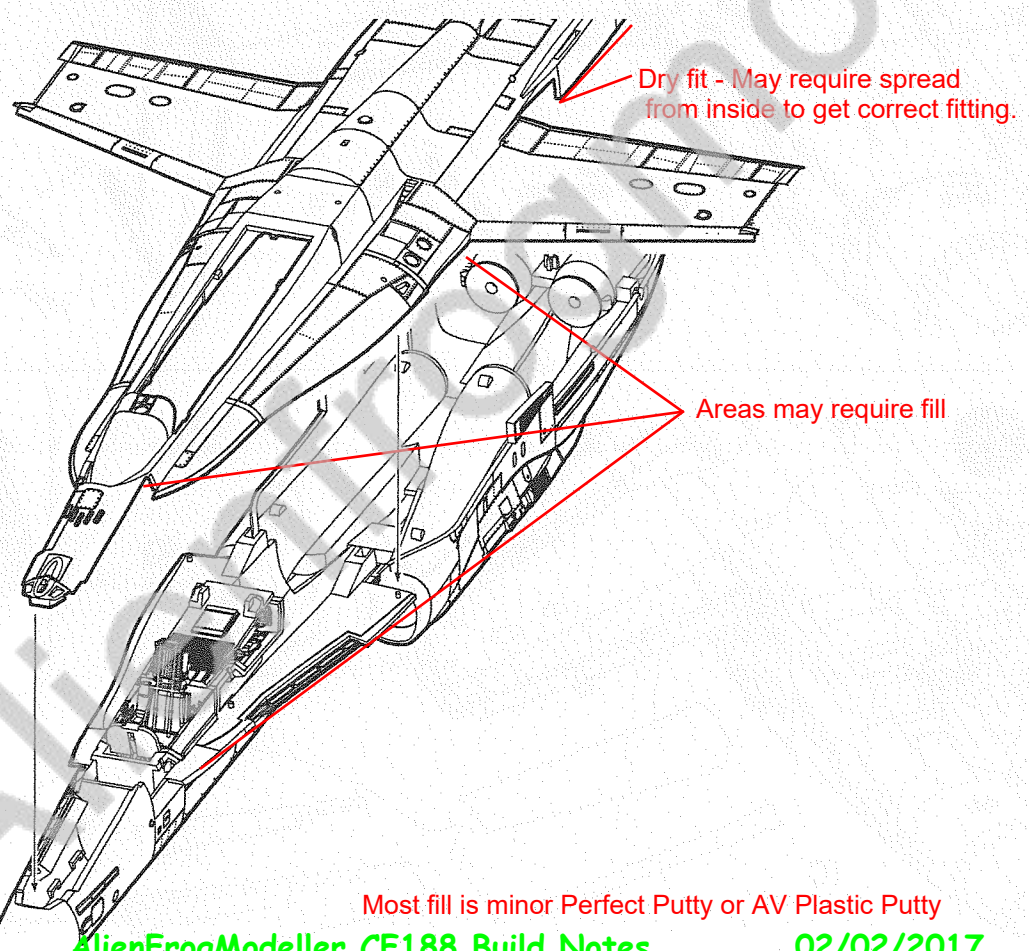

Most fill is minor Perfect Putty or AV Plastic Putty

19

C11 (C12)

C21 (C20)

Body is white - fingers are external colors

PE9 (PE9)
A:MIG-011

C1 (C3)

PE13 (PE15)
A:MIG-011

Inside H11 Gunze

*Wing Fold is 100 Degrees up from the wing spread position

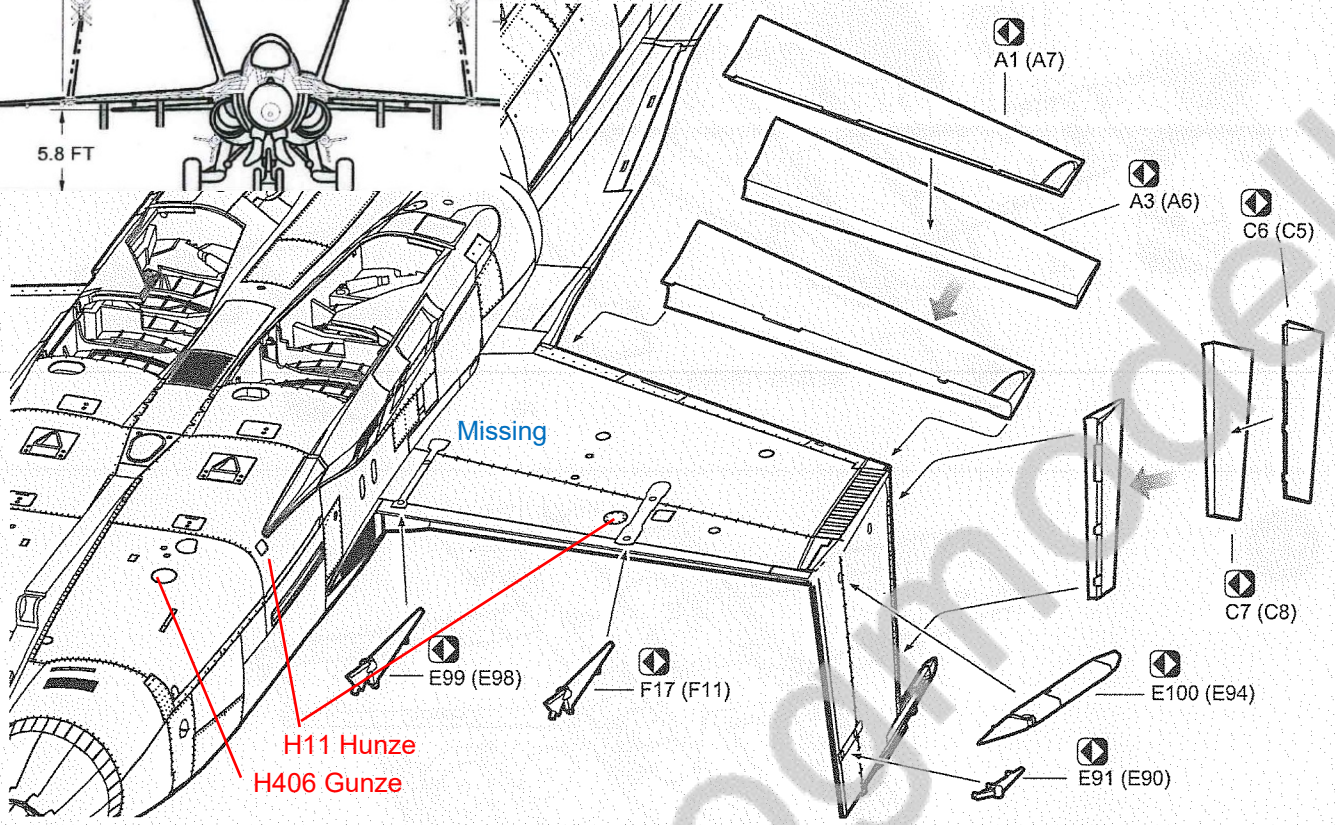
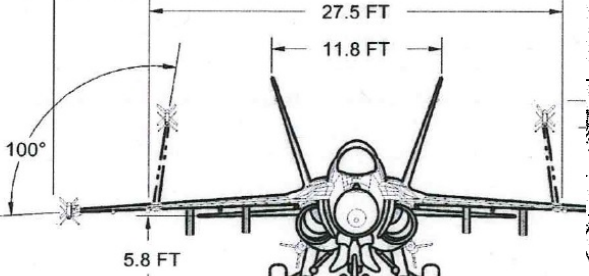

H11 Hunze
H406 Gunze

21

C2 (C4)

C10 (C9)

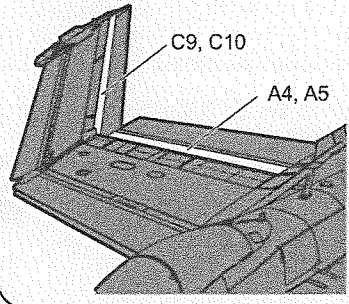

Position of A4, A5, C9, C10

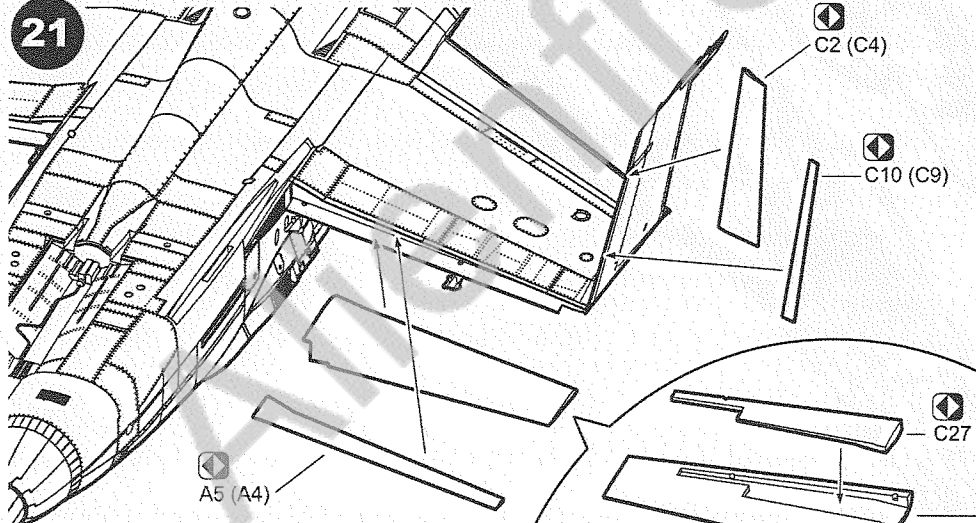

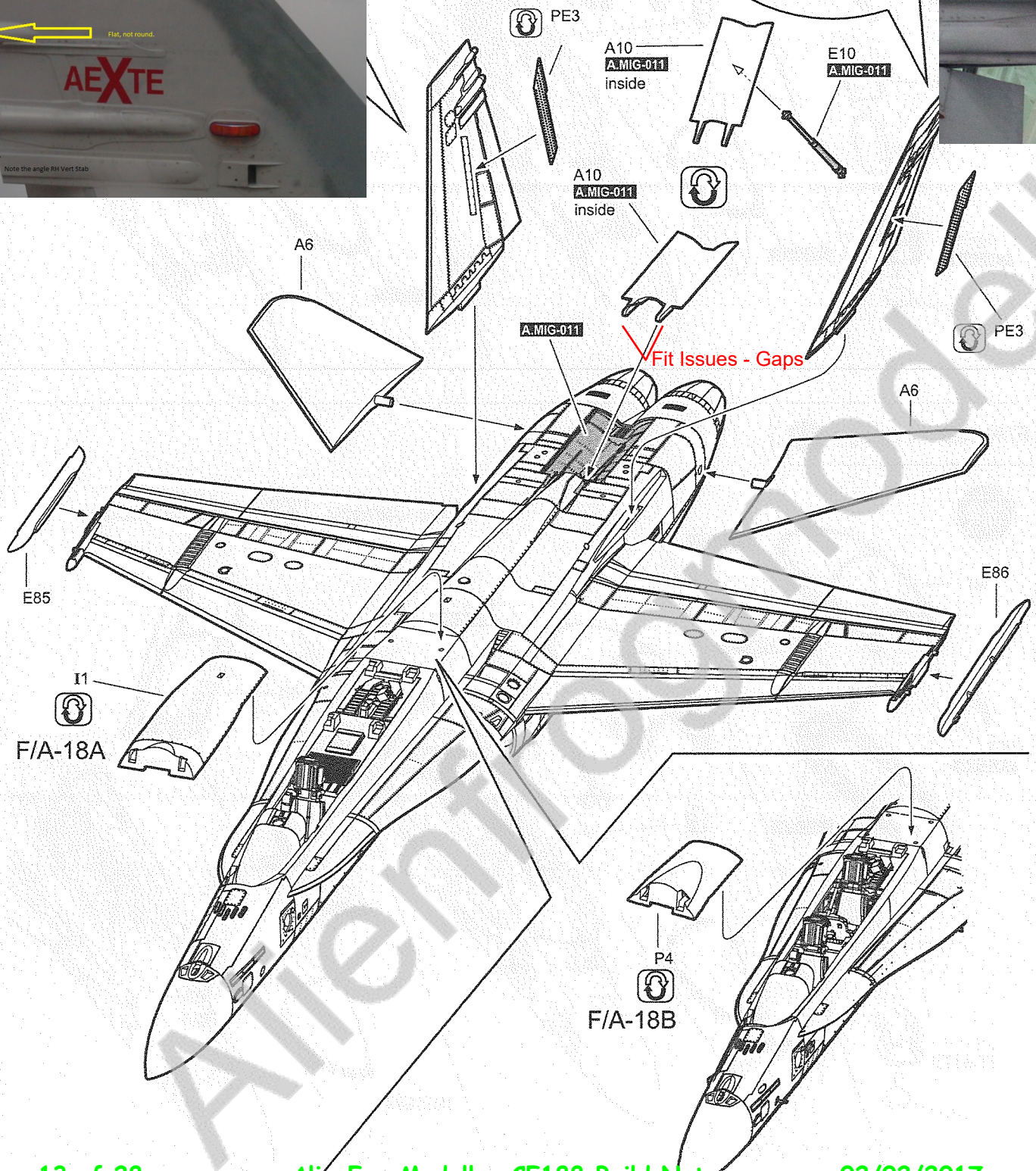
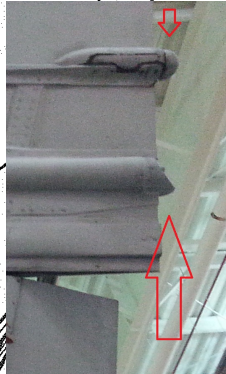
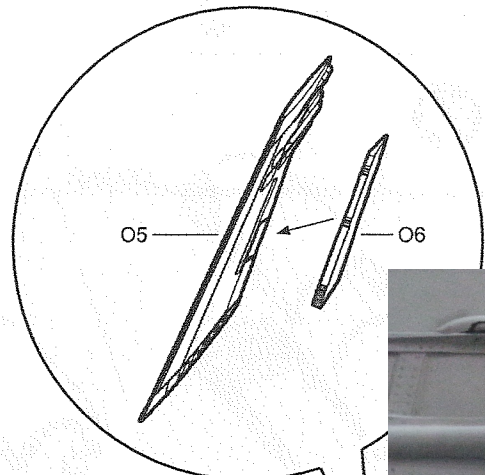
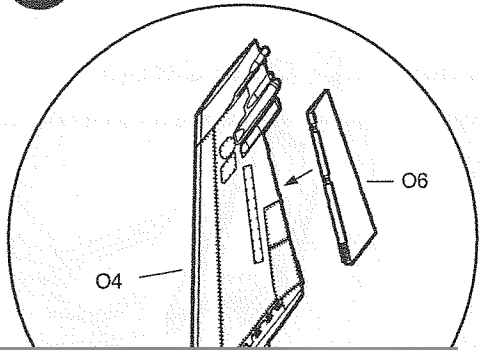

23

Close Canopy  Open Canopy

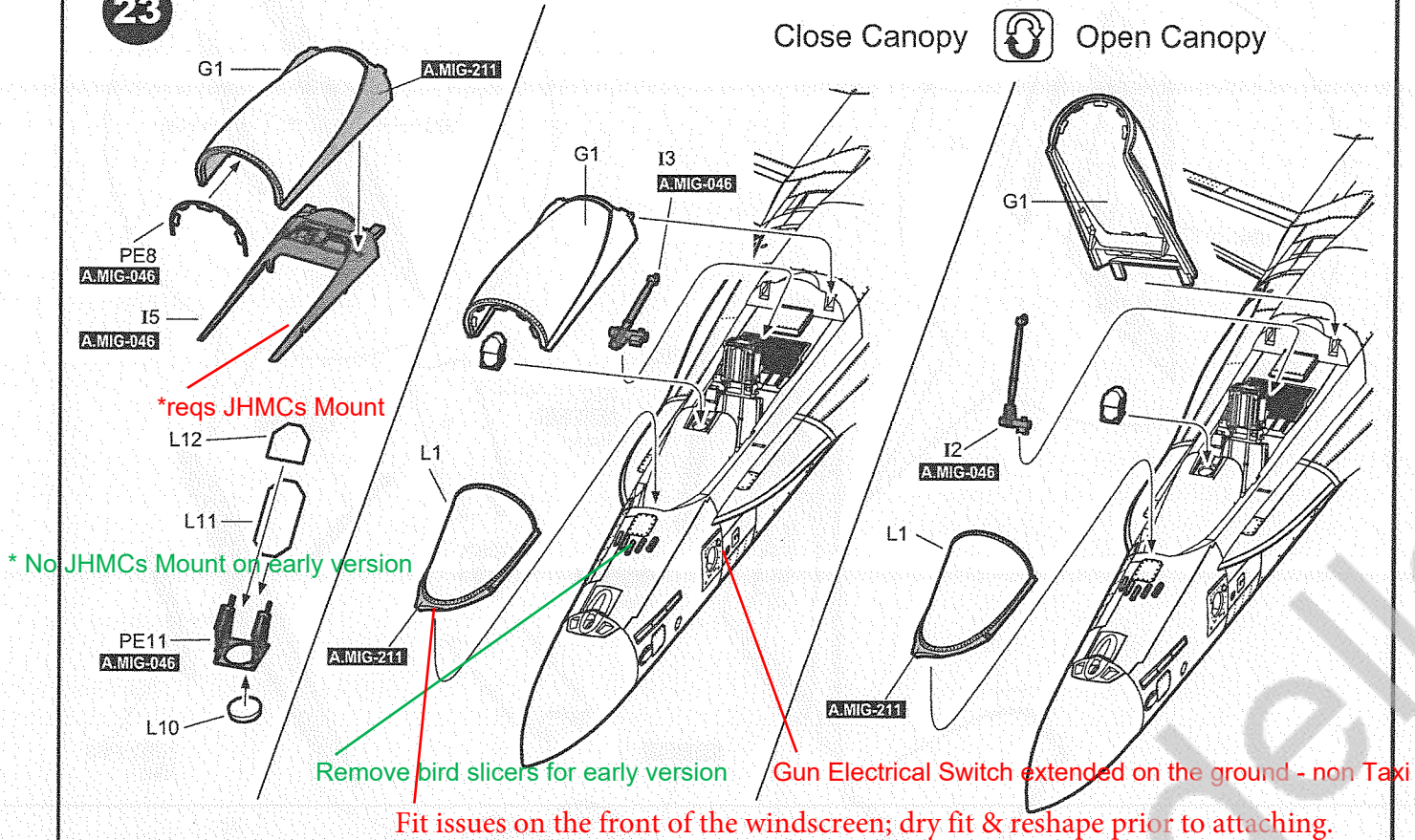

24

Micromesh Canopy - Dip Windscreen and Canopy in Future after - Creates the purple haze

Close Canopy  Open Canopy

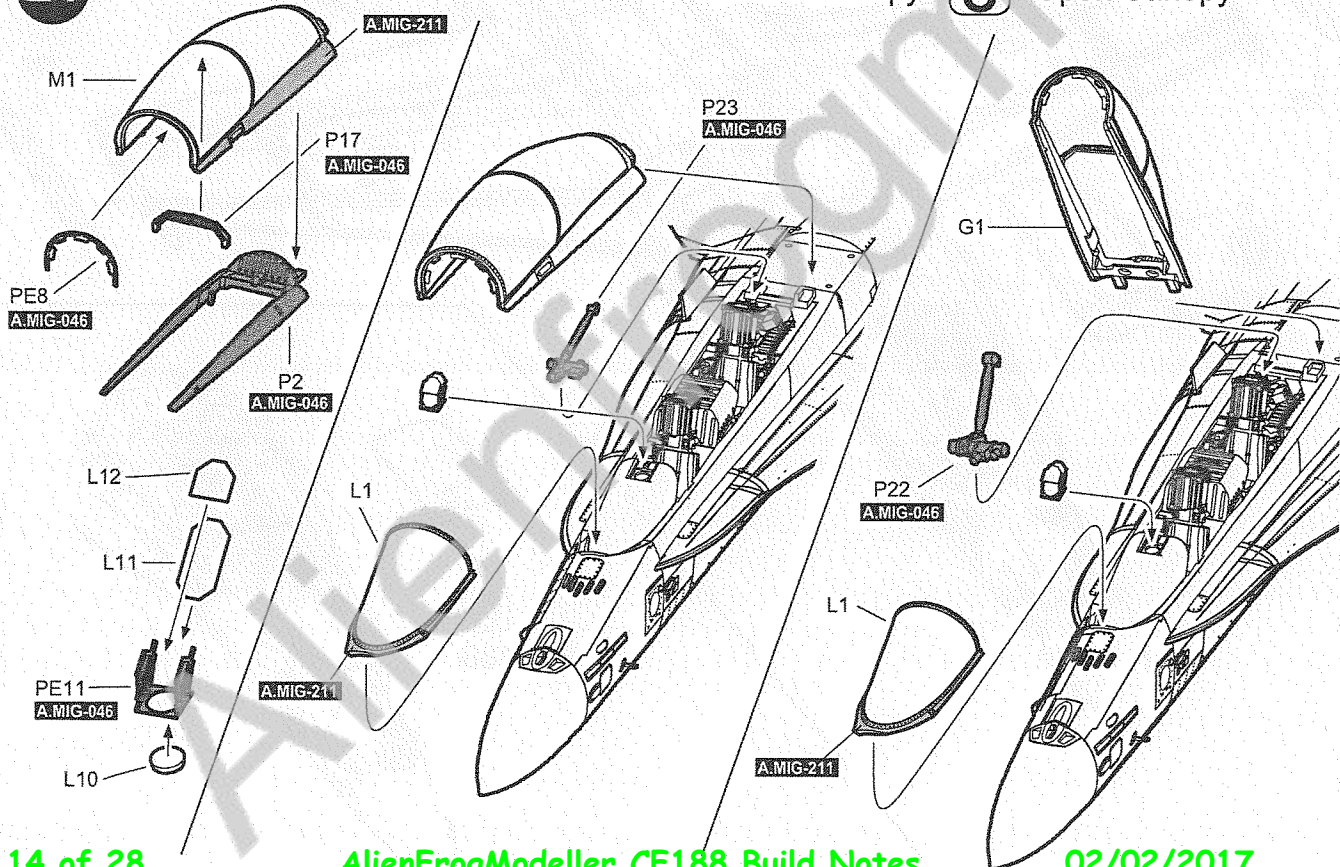

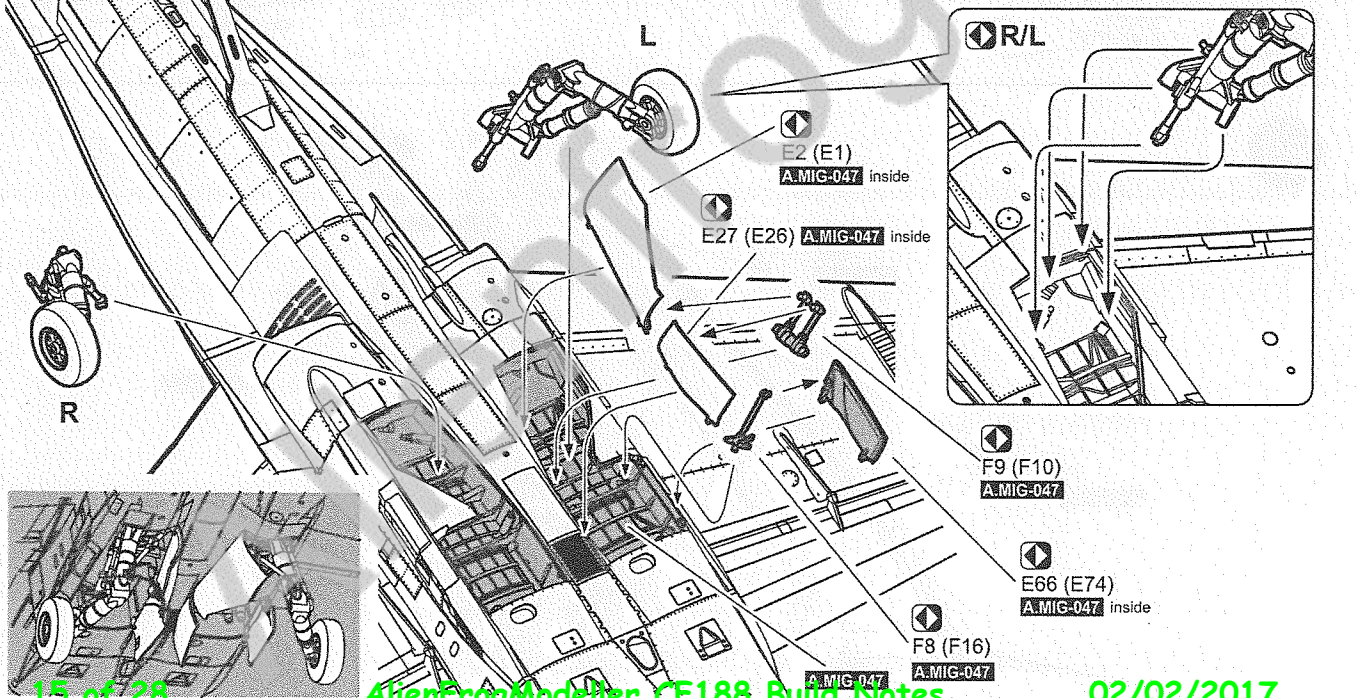
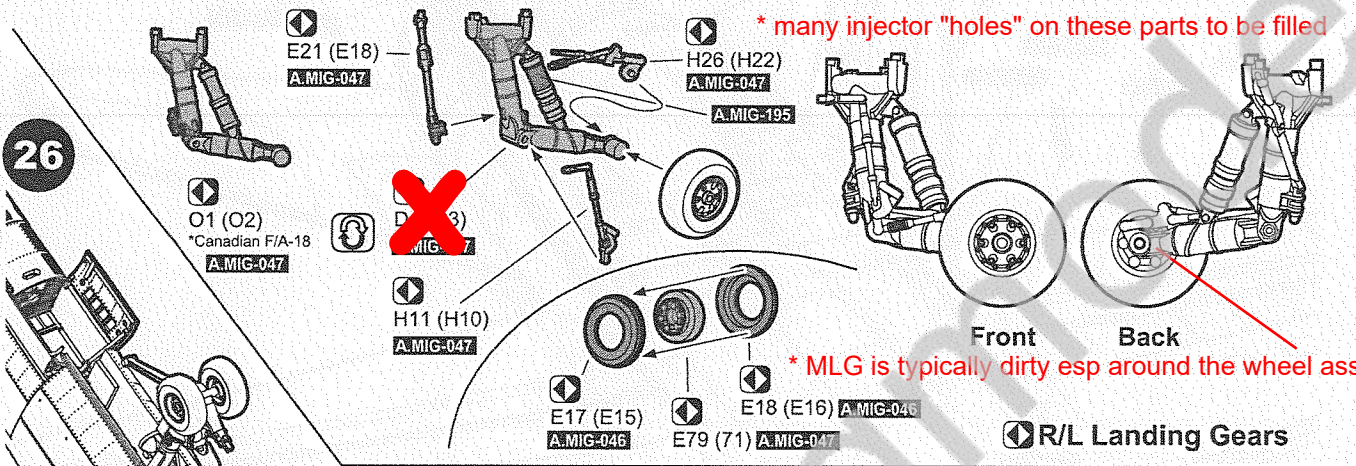
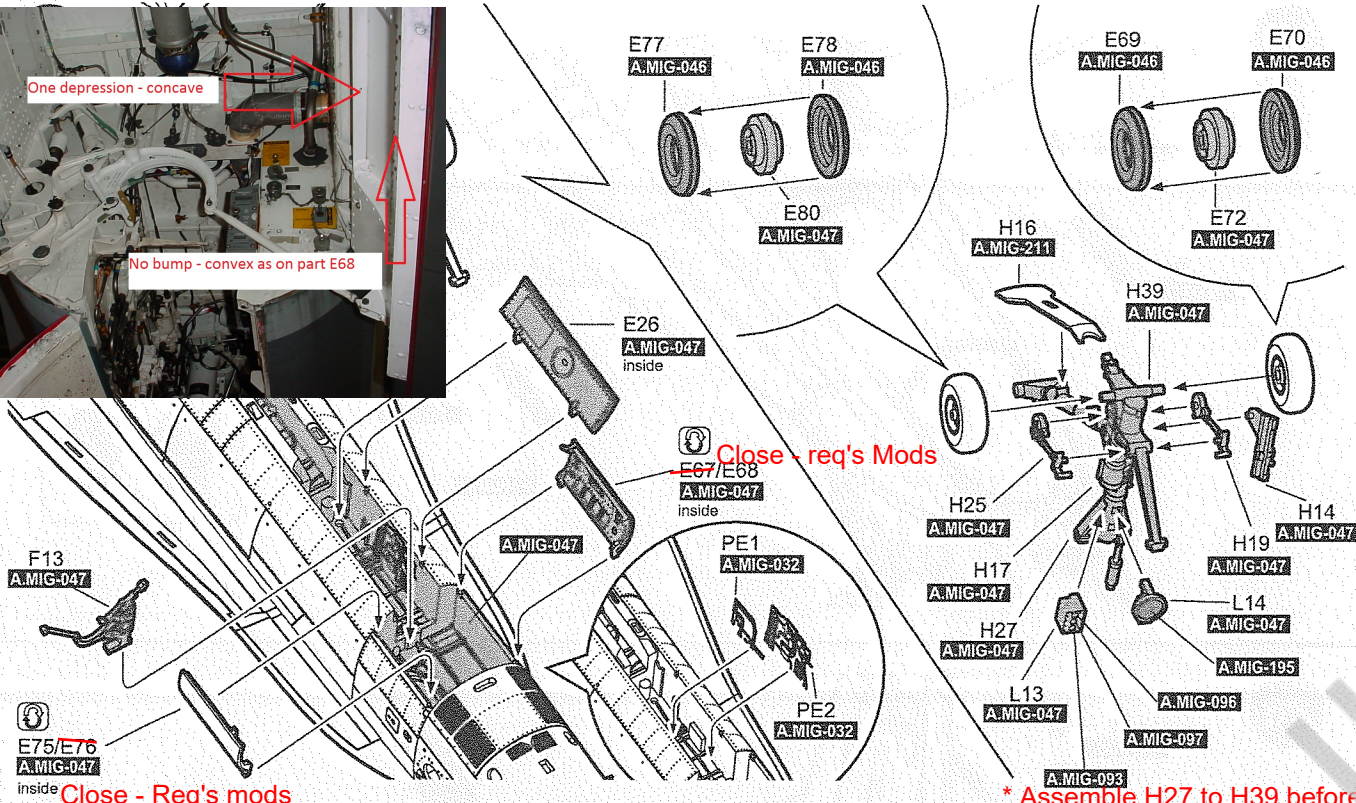
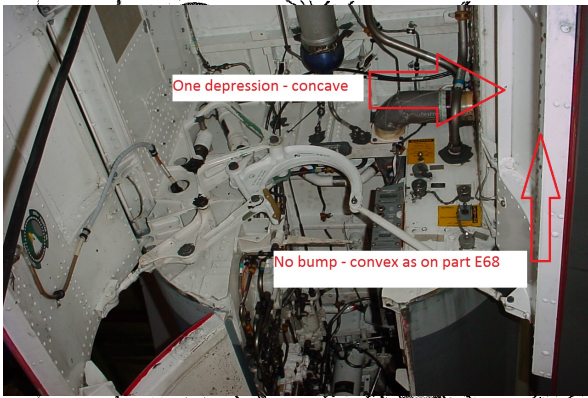

27

CRPA Mod req'd

*Nav Lights appear darker when no power green looks like blue with power off

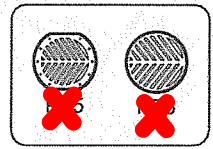
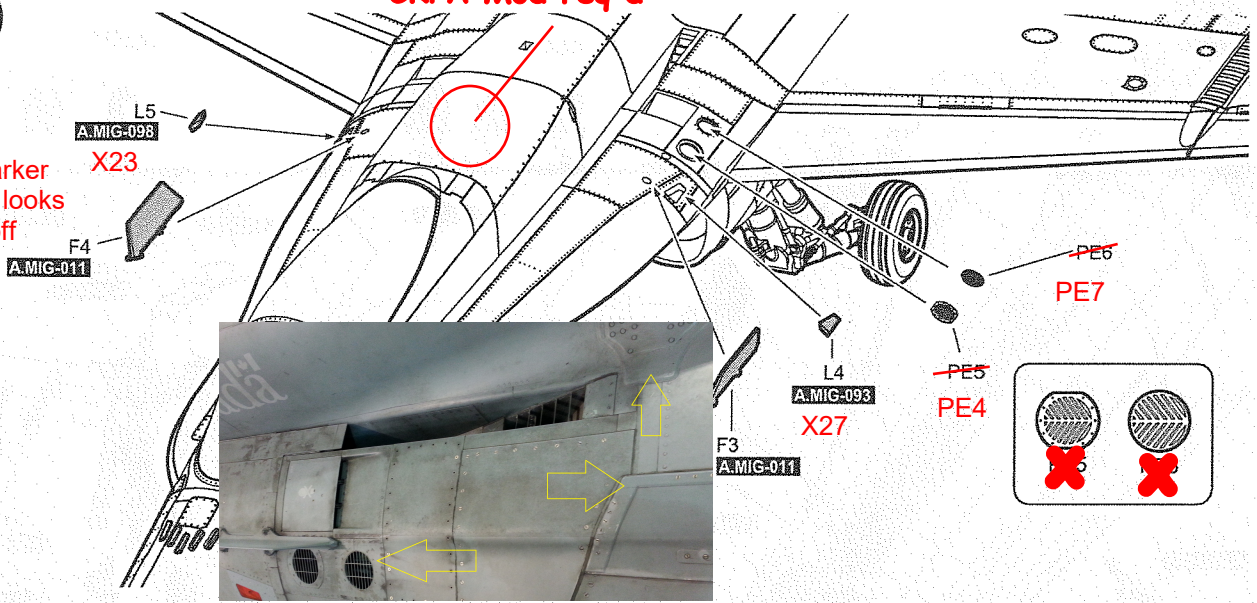

28

E48 to E50 Req'd

E50 to 53 Req'd

E82 - Req for early version

*For Early E33

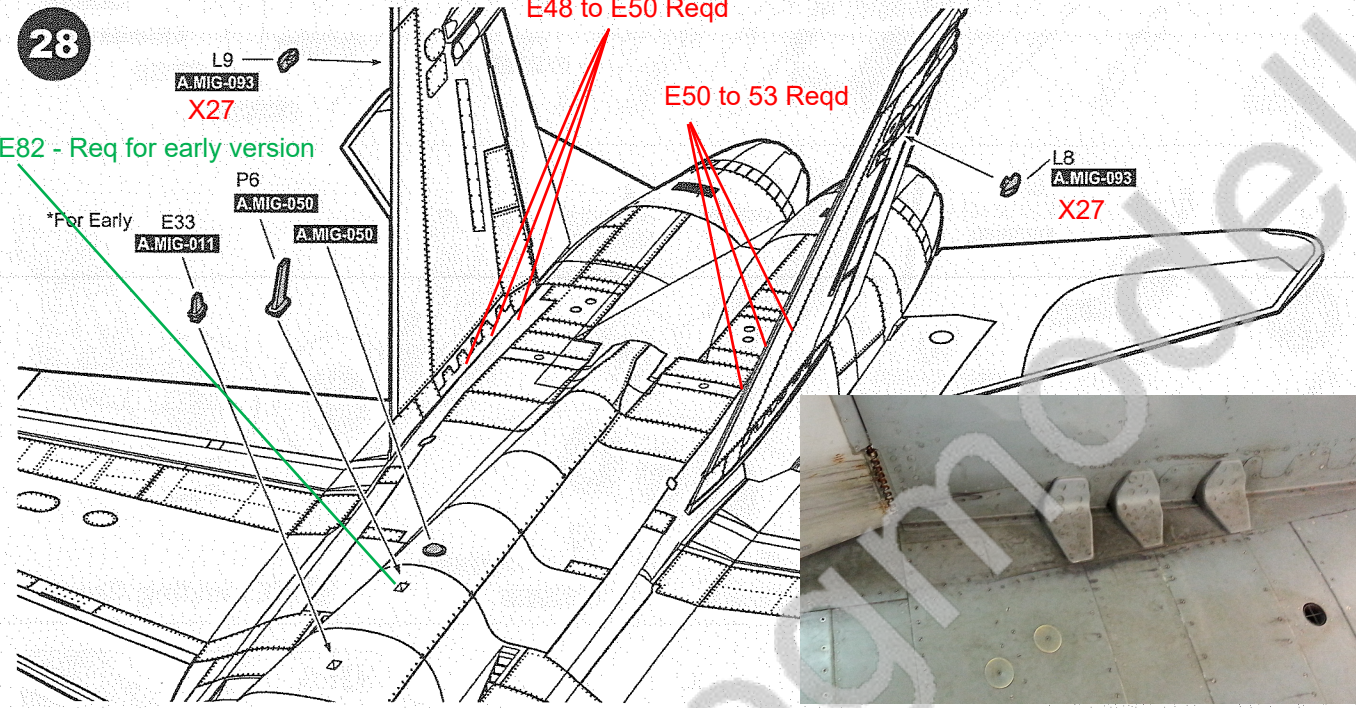

29

*Typical Udder + "Fat" Pylon No Udder + Normal Pylon

Early Version requires Ant Like E82

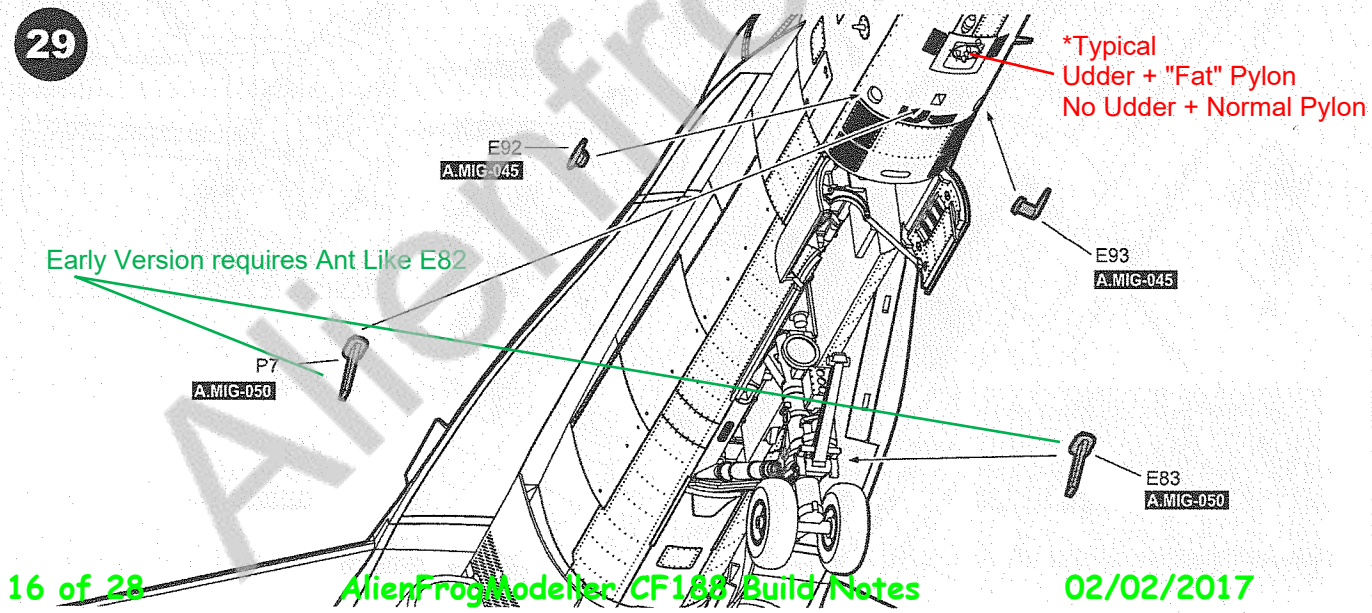

30

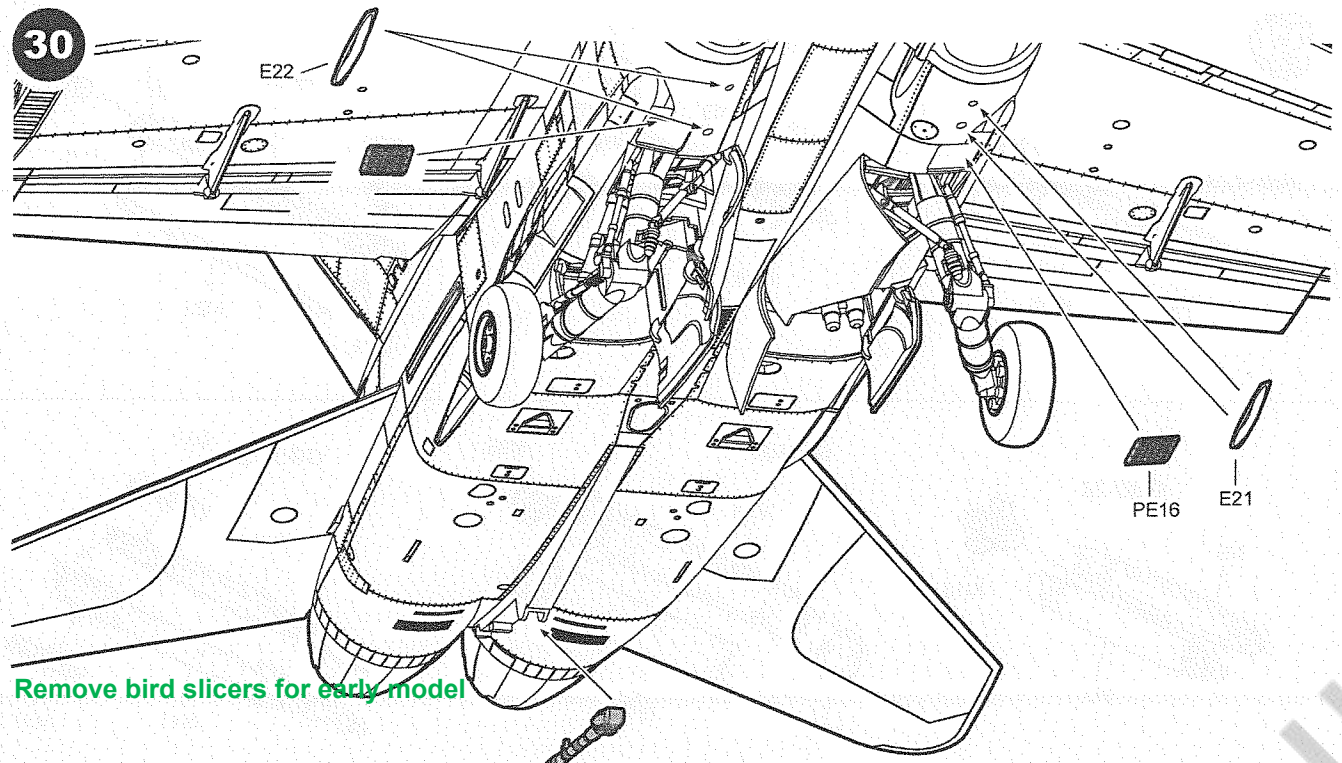

Remove bird slicers for early model

E9
A.MIG-011

H308 & H337 Gunze Tail Hook colors

31

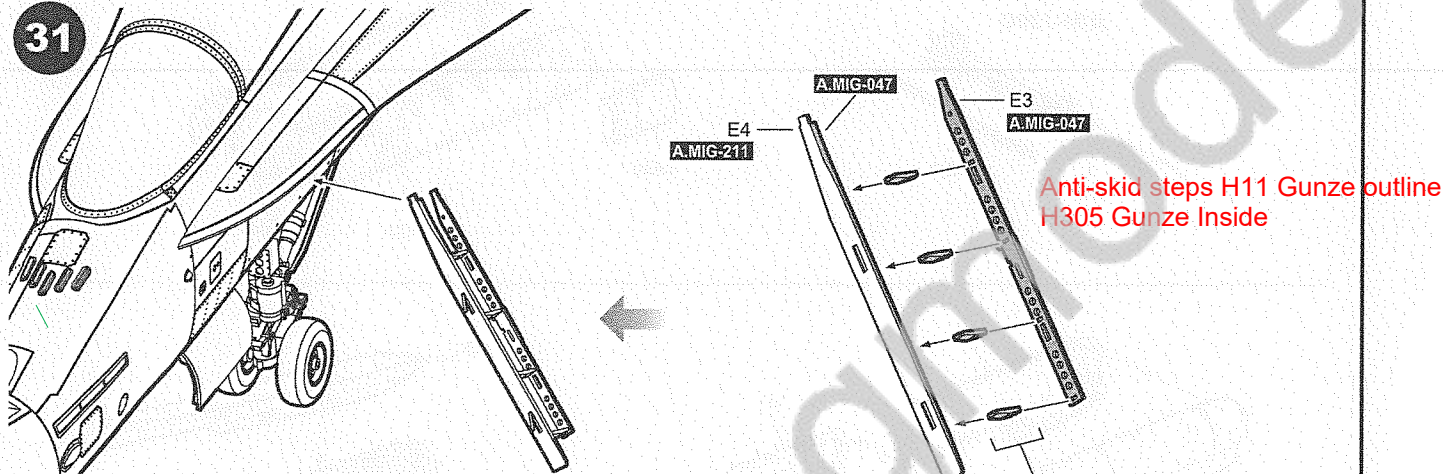

Missing Boarding Lader parts - F12 & F14

Anti-skid steps H11 Gunze outline
H305 Gunze Inside

E37, E38, E54, E55
A.MIG-047

32

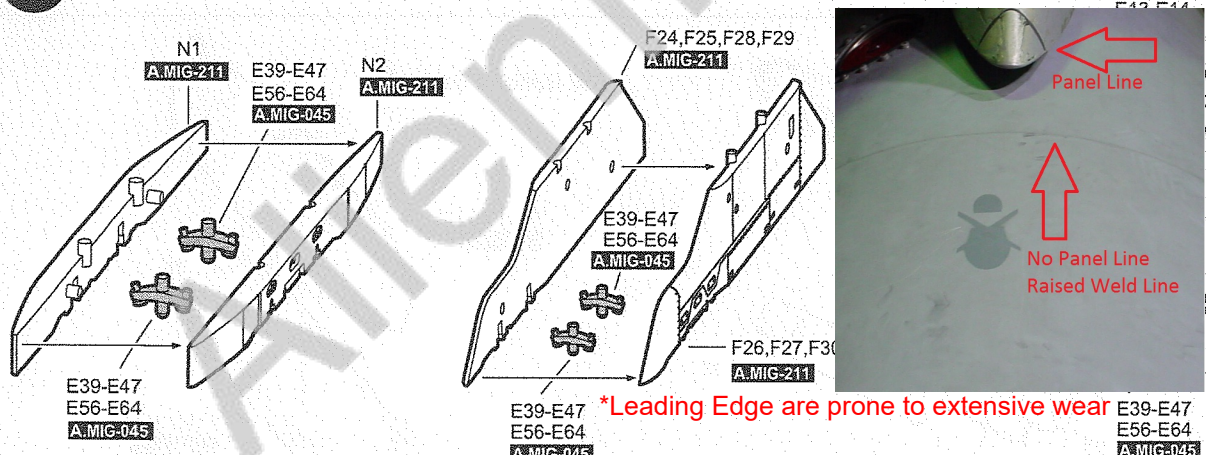

x2

E39-E47
E56-E64
A.MIG-045

F24, F25, F28, F29
A.MIG-211

E39-E47
E56-E64
A.MIG-045

F26, F27, F30
A.MIG-211

E39-E47
E56-E64
A.MIG-045

*Leading Edge are prone to extensive wear

Panel Line

No Panel Line
Raised Weld Line

AIM-120B

M1 M20

AIM-9M

M14 M19 M3 M19 M14

AIM-9X

M25 M24 M23 M7 M25 M23 M22



GBU-38

M9 M18 M8

GBU-87

M1 M26 M27 M16

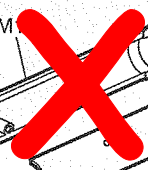

GBU-12

M17 M10 M11 M17

Current inventory GBU-38 and GBU-49

AIM-120C

M2 M21

AAQ-28

GG5 GG2 GG6 GG1

SNIPER XR

I14 I11 I13 I12 I15 L7 L5 Tint with X19

E65
~~AAQ-28~~
36495
H338 Gunze

Current Pod in use

Early Version Homets only

36495
H338 Gunze

AAS-38

E8 E31 E73 E23 E25

330 Gallons Tank x3

F18,F20,F22
AMIG-211

Fill recessed lines

F19,F21,F23
AMIG-211

CRPA Mod after Op Impact

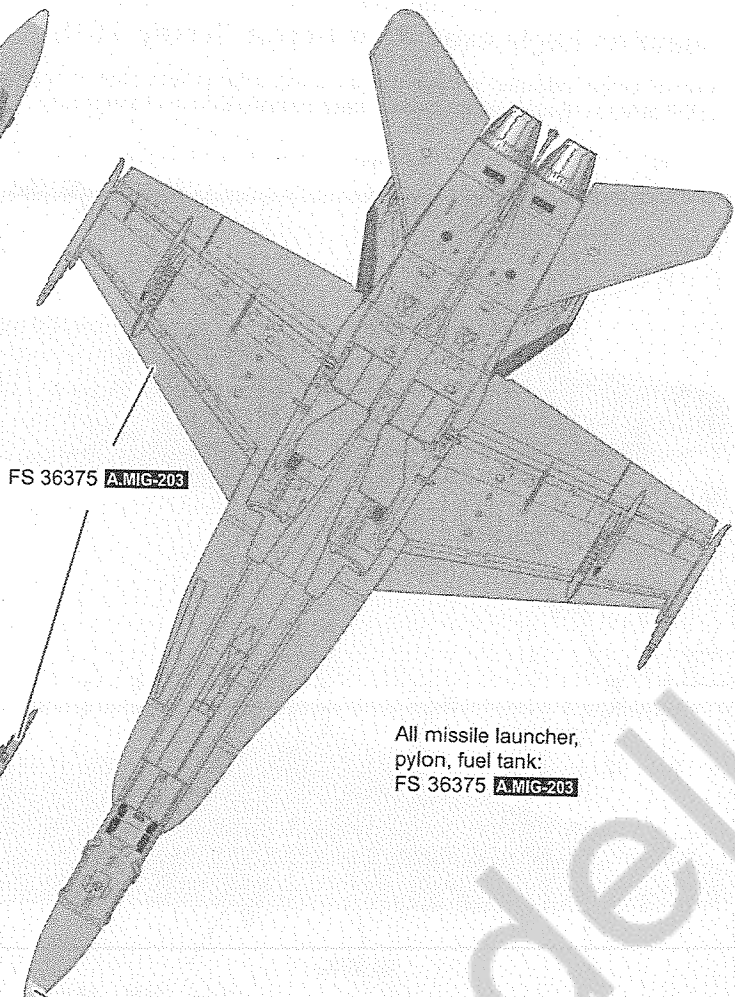
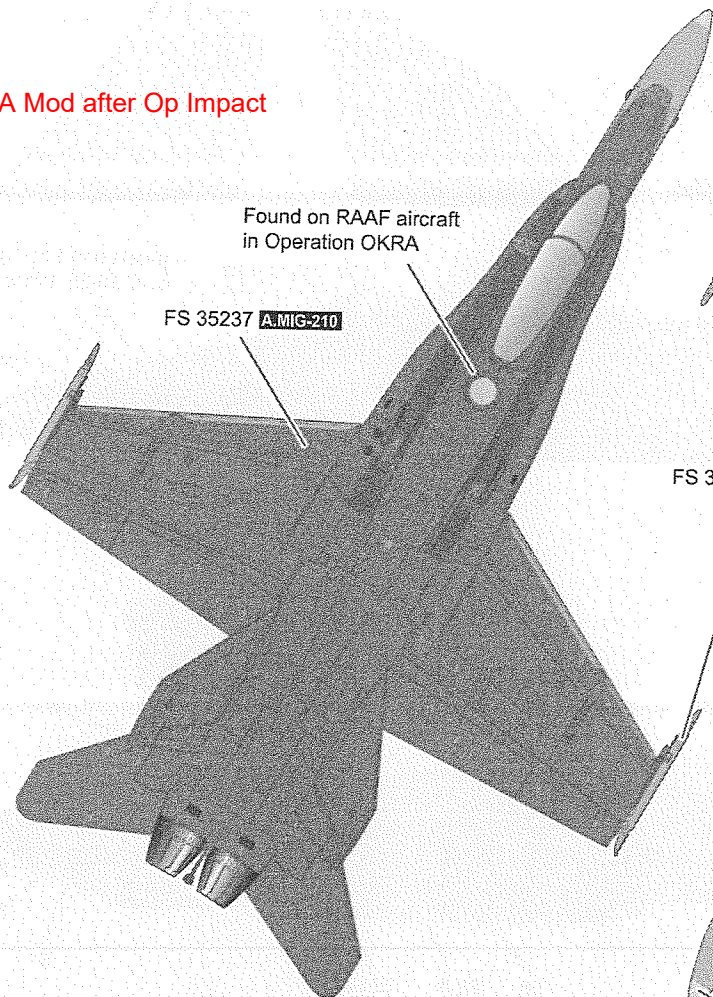

11. SPAF Colors

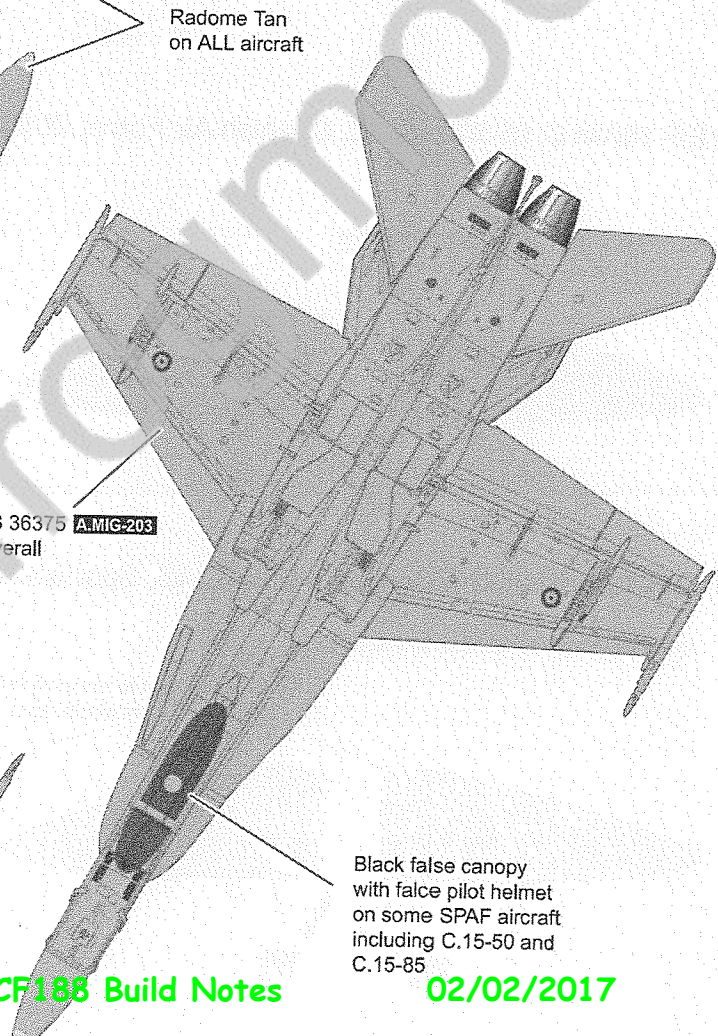
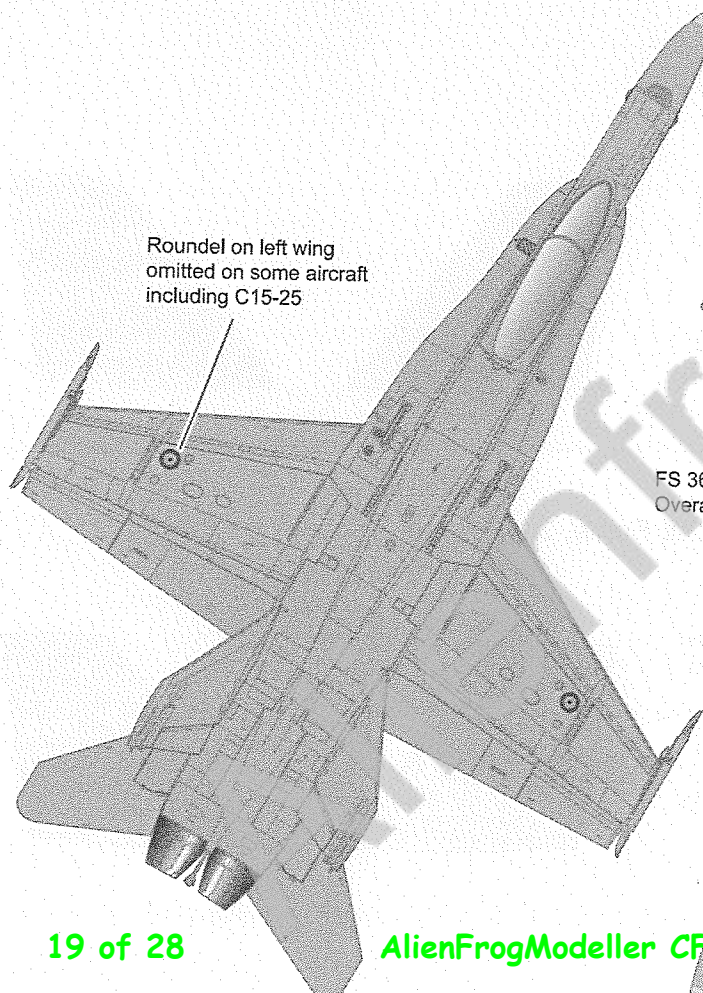

Anatolian Eagle exercise in Konya, Turkey, 2015.

All SPAF aircraft indicated here are equipped with catapult launchbar on nose gear but IFF antenna "Bird slicer" have NOT been installed in front of the canopy

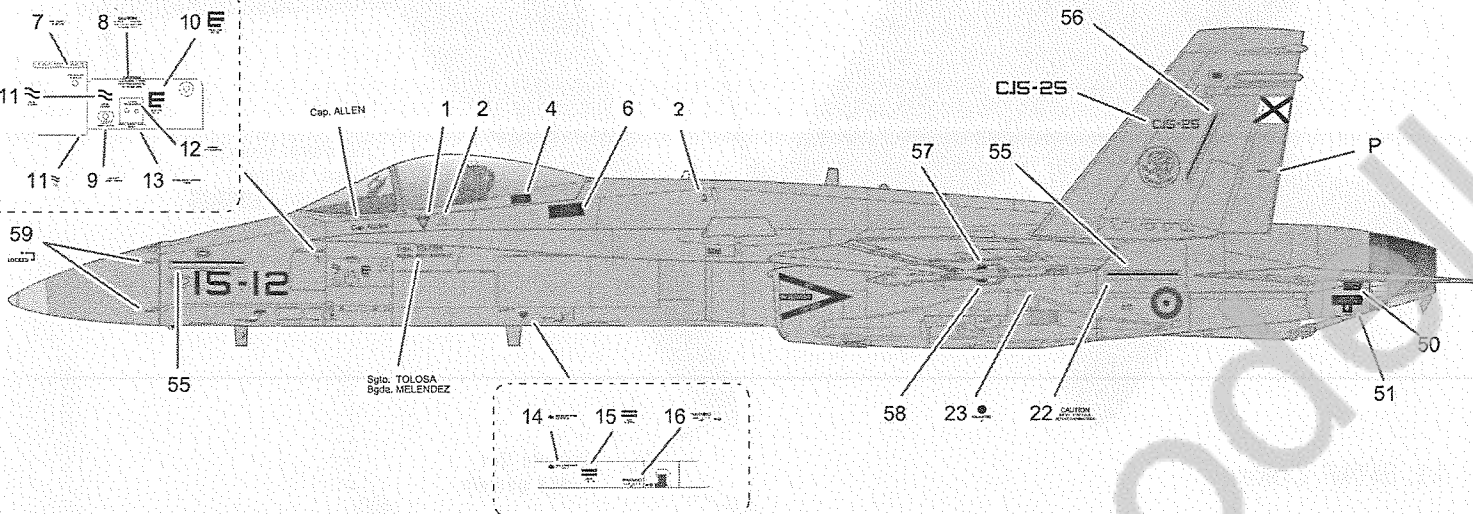
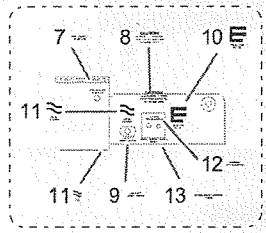
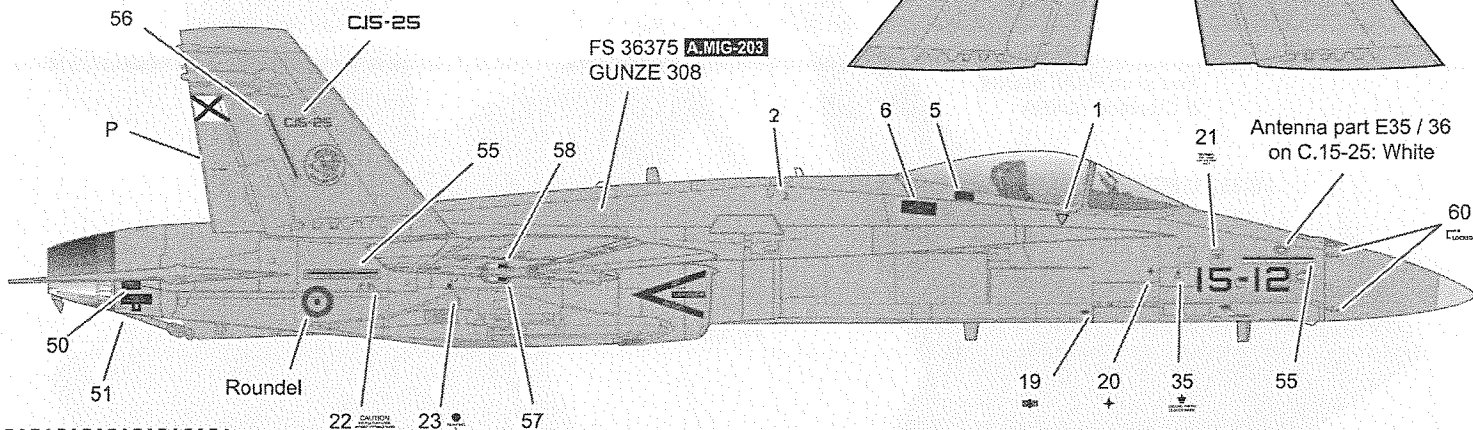
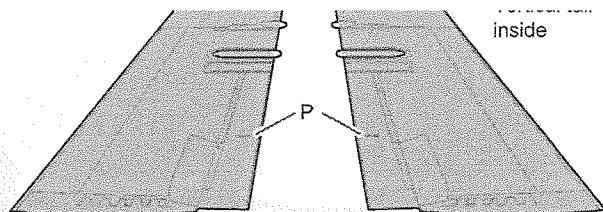

8. EF-18AM C.15-50, Ala 12, Spanish Air Force, 2016.

Other markings are identical with above

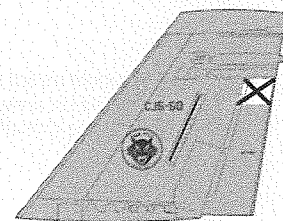
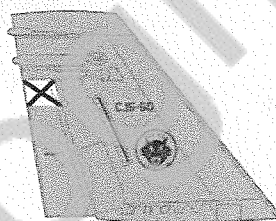
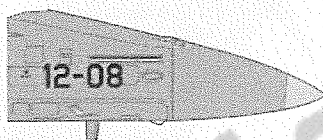
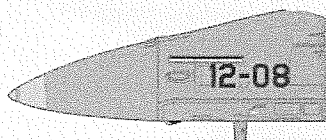

9. F/A-18A+(ex US Navy) C.15-85, Ala 46, Spanish Air Force, 2016.

Other markings are identical with above

No "Black Bar" on formation light
Also use no.57 for wingtip light

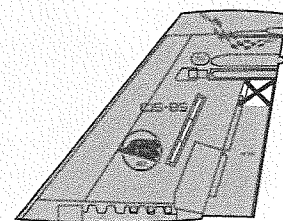
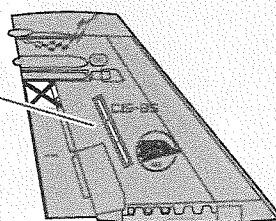
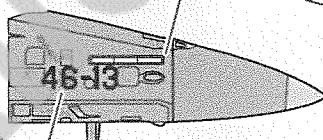
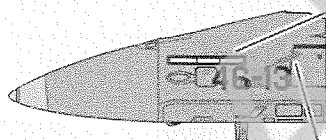

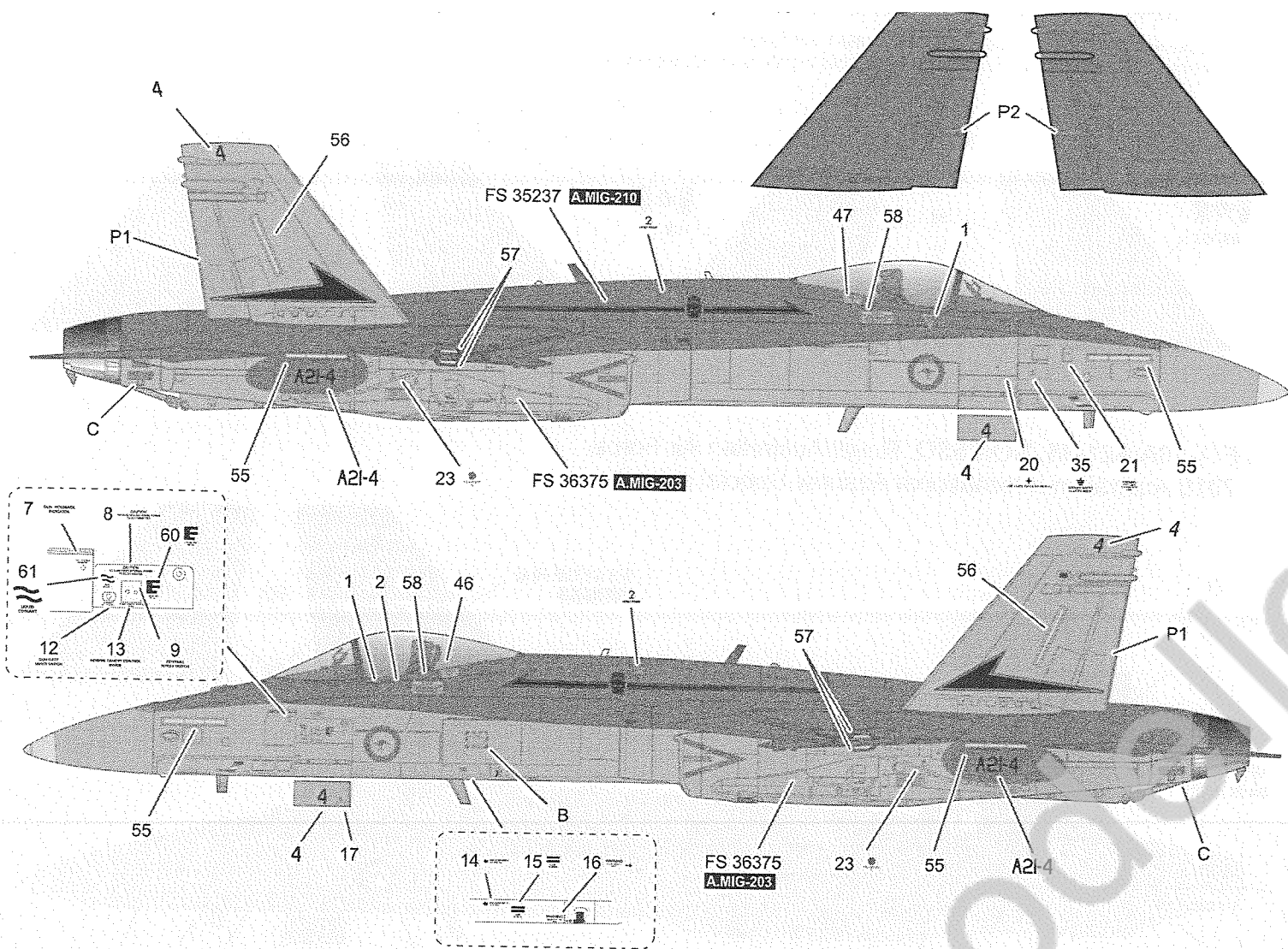

6. F/A-18A A21-57, NO.3SQ, Royal Australian Air Force, Operation OKRA against ISIL, 2015.

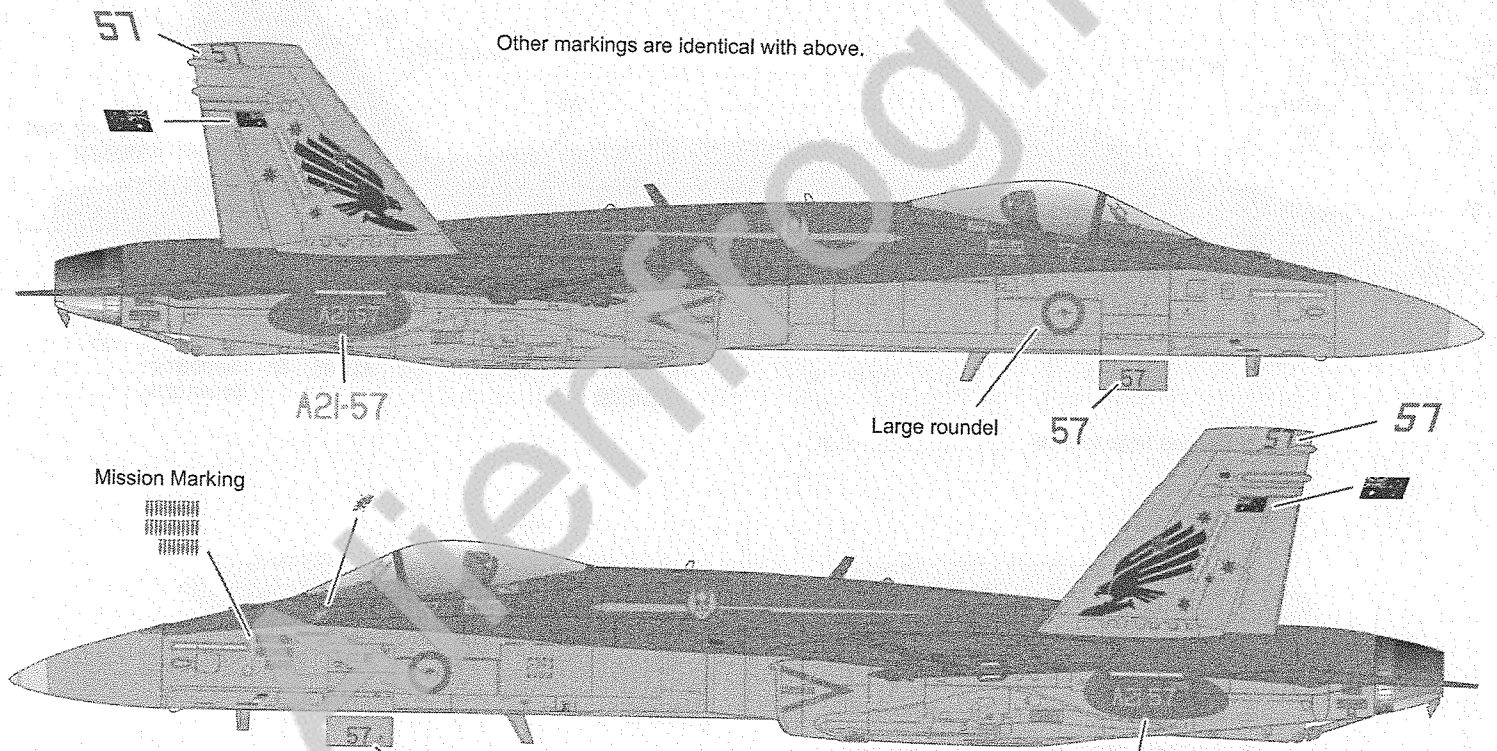

Options provided: 188756, 188788, 188797 (CF-188A) and 188917(CF-188B)
 Some combination on numbers may required, and other markings are identical with other SQNs.

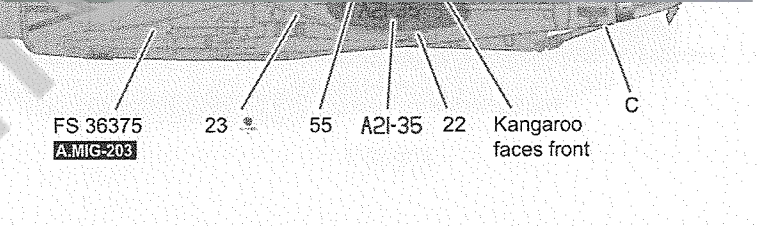
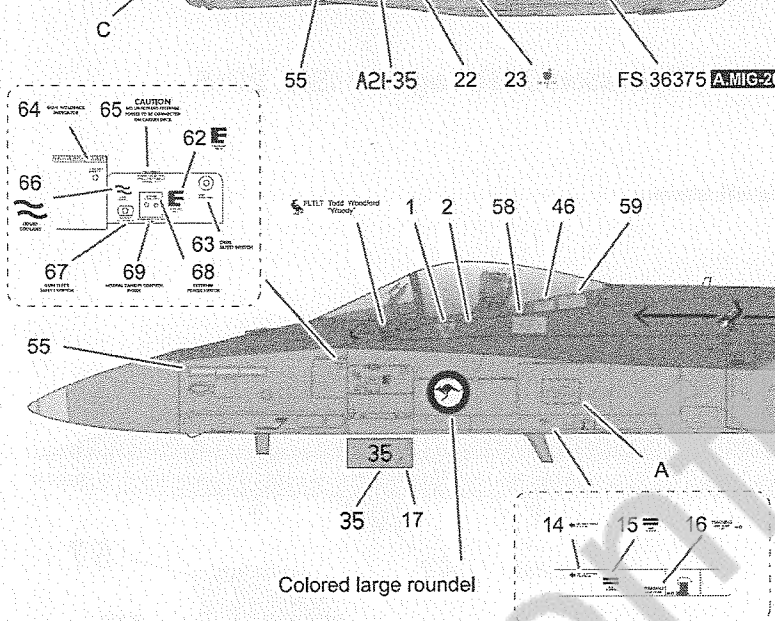
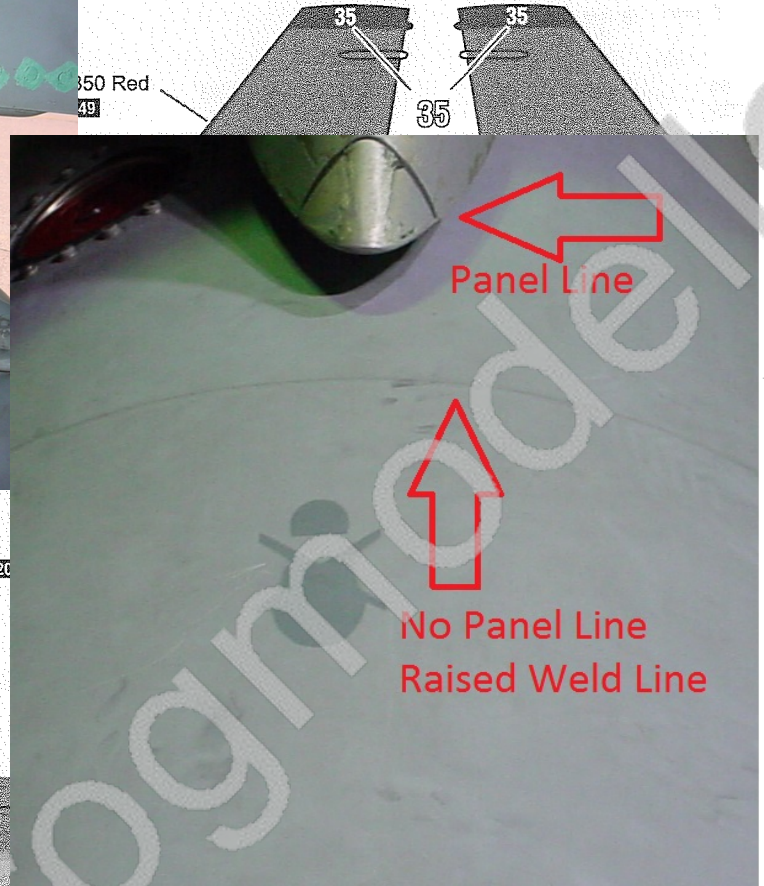
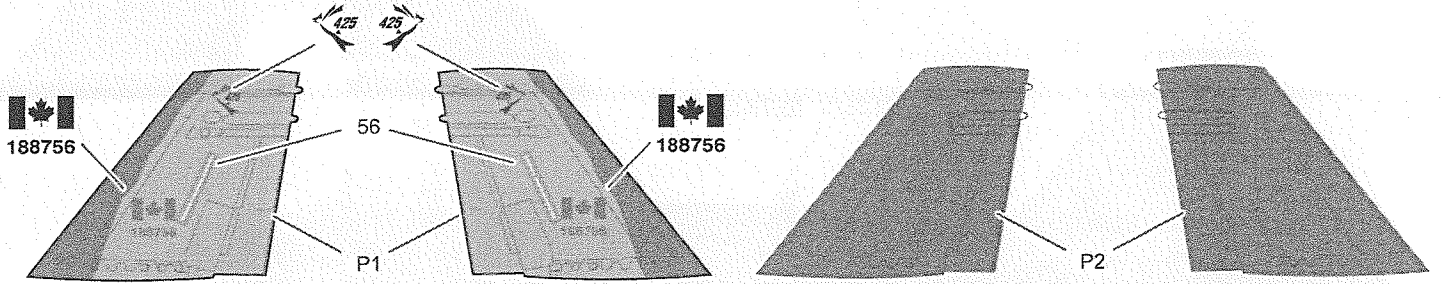

Slightly raised weld lines

No engraved lines on the ext tank, fill.

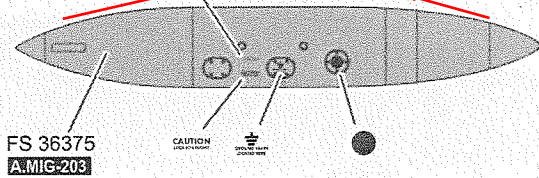
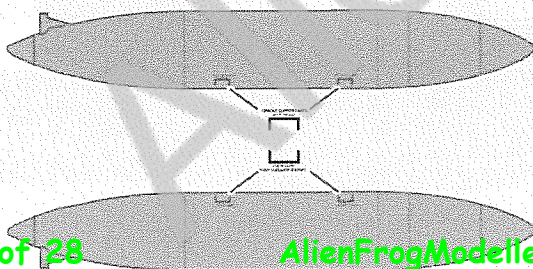

External tank markings

Options provided: 188747, 188794
Some combination on numbers may required

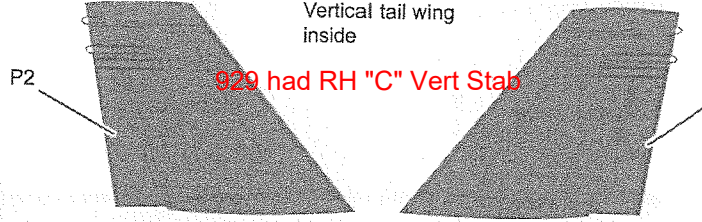

929 had RH "C" Vert Stab

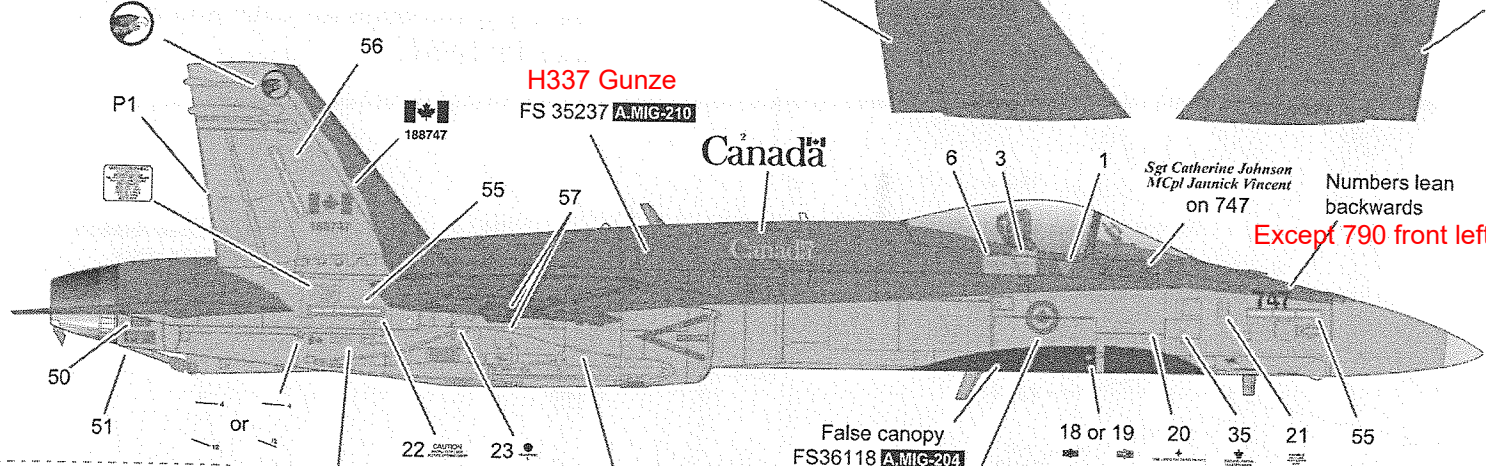

H337 Gunze
FS 35237 A.MIG-210

Numbers lean backwards
Except 790 front left

False canopy
FS36118 A.MIG-204

Roundel (small)

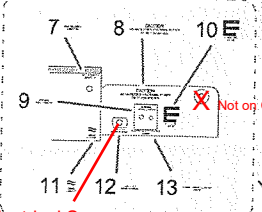

Capt Darren Blakie
"Baja"
on 747

Not on Canadian jets

FS 36375 A.MIG-203
H308 Gunze

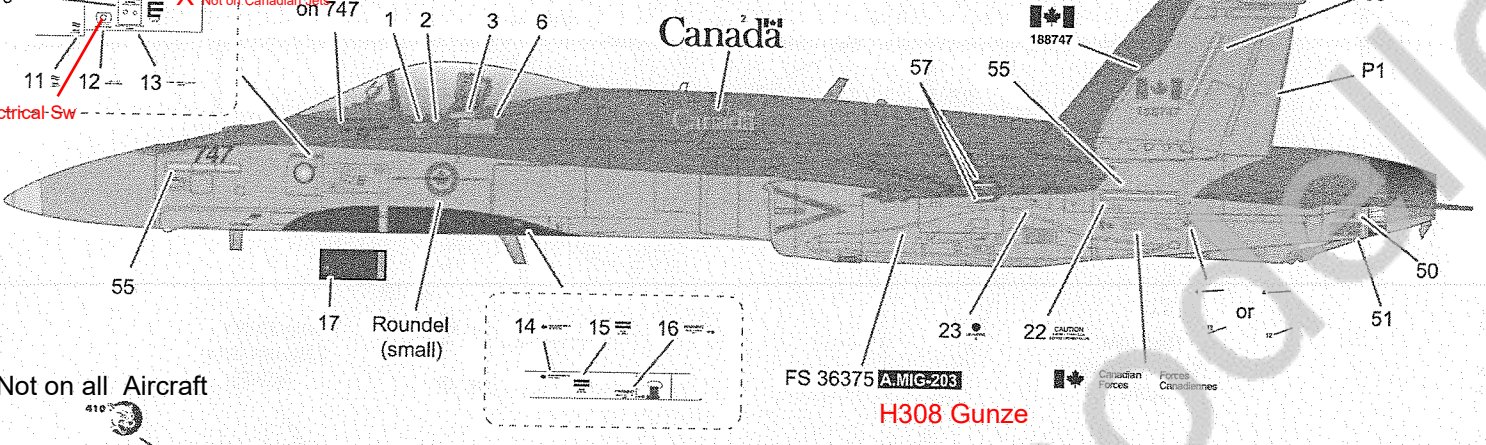

Gun Electrical-Sw

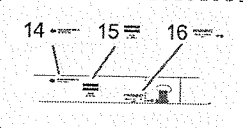

Not on all Aircraft

H308 Gunze

2. CF-188A/B, 410SQ, Canadian Air Force, Jun, 2016.

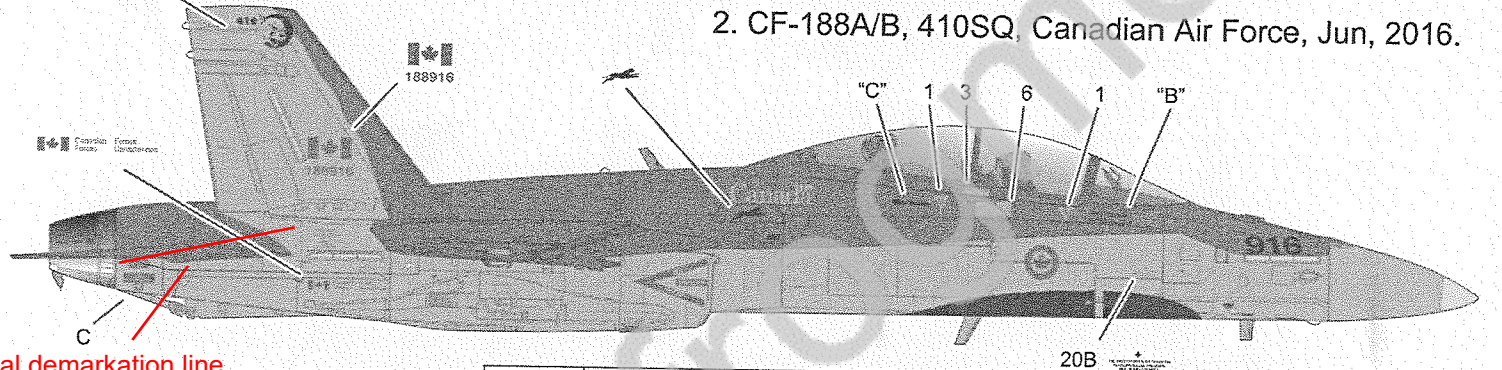

Typical demarkation line
Horz Stab at rest.

A/C No.	188916	188932	188937	188938
"A"	Capt Myers "Slah"	Capt Park "Trailer"	Capt Guilbat "Whaler"	Capt Walker "Shrek"
"B"	CMpl Pichelle COTM Oct 2014	Cpl Belanger	MCpl Hill FPC S3	Sgt Poole
"C"	MCpl Brooks		Cpl Fisher	Cpl Northcott

Provided CF-188B
(double seater)
serial / crew names

Mission marking
on 785 only

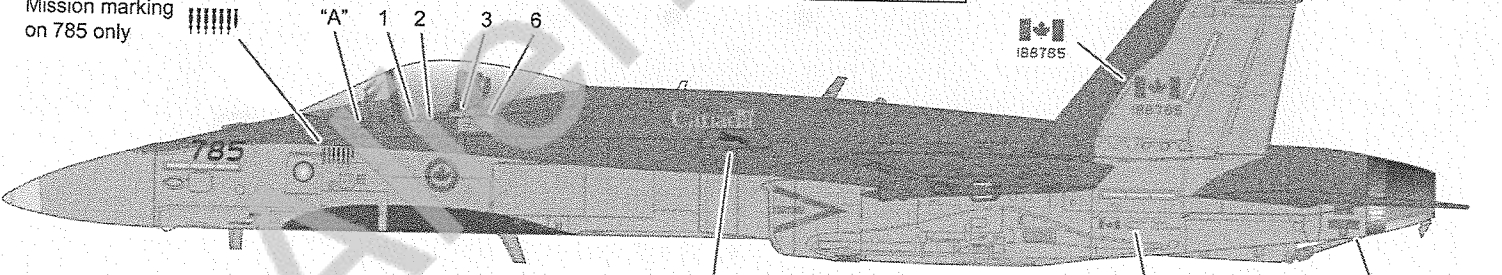

Provided CF-188A
(single seater)
serial / crew names

A/C No.	188785	188793
"A"	Maj Lewis "Singe"	Capt Hannam "Tyson"
"B"	MCpl Robitaille COTM Apr 2015	

Tip of Radome Silver

Radome H318 Gunze

Use grey markings for CAF and RAAF, black for SPAF.

Canadian Door 5 - front Ant was offset not centered.
Udder - If EW gear was installed w/"Fat" Pylon stn 8.

SPAF roundel location, on both wings.

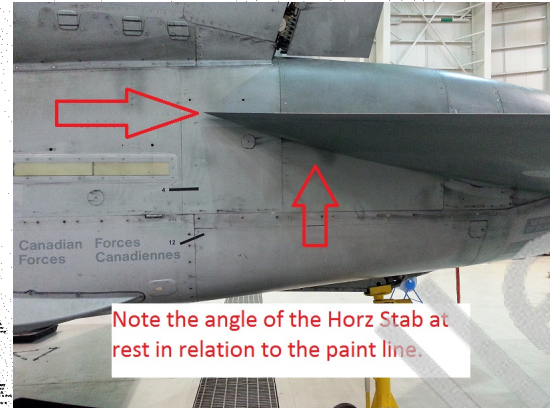
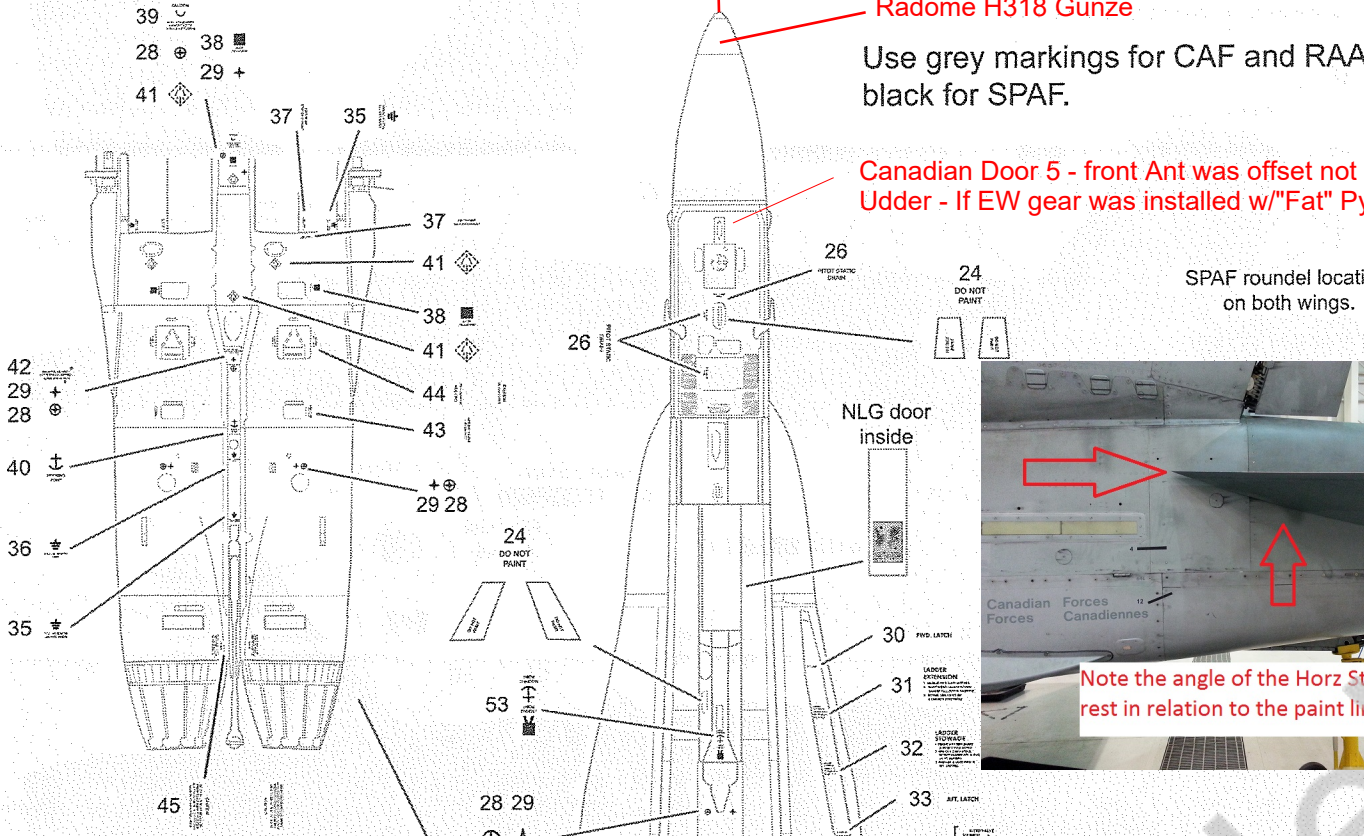

Note the angle of the Horz Stab at rest in relation to the paint line.

Roundel, Medium Gray (CAF)

Aircraft No., Medium Gray (CAF)

Underside Decals missing

RAAF Roundel location on both wings, Kangaroo legs to inside.

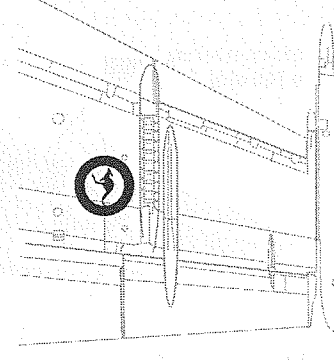
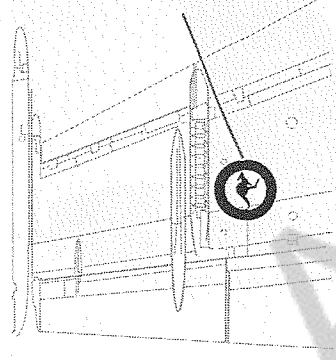

Use Light ghost gray markings for RAAF, Black for SPAF.

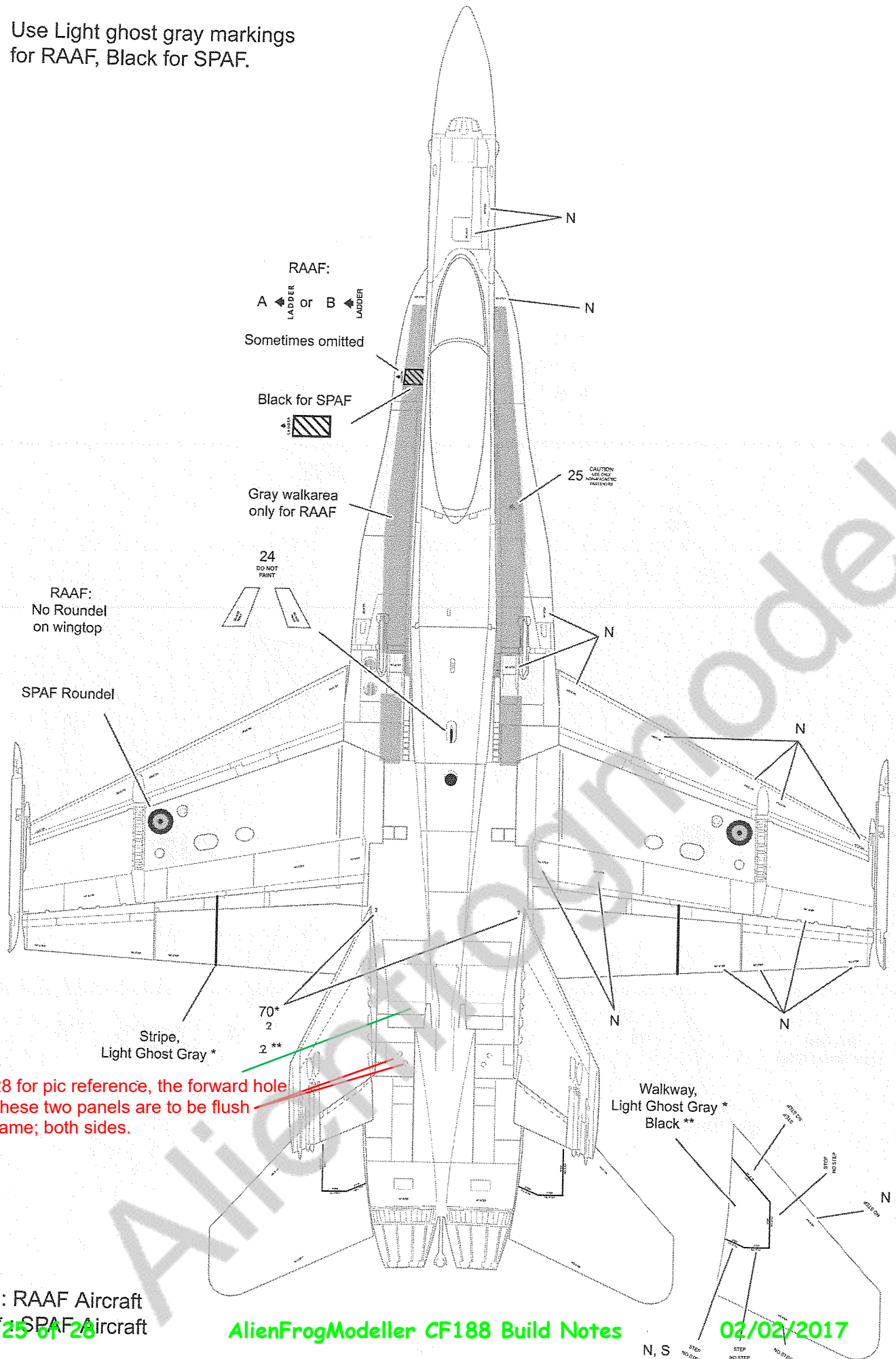

Go to Step 28 for pic reference, the forward hole is correct. These two panels are to be flush with the airframe; both sides.

* : RAAF Aircraft
 ** : SPAF Aircraft

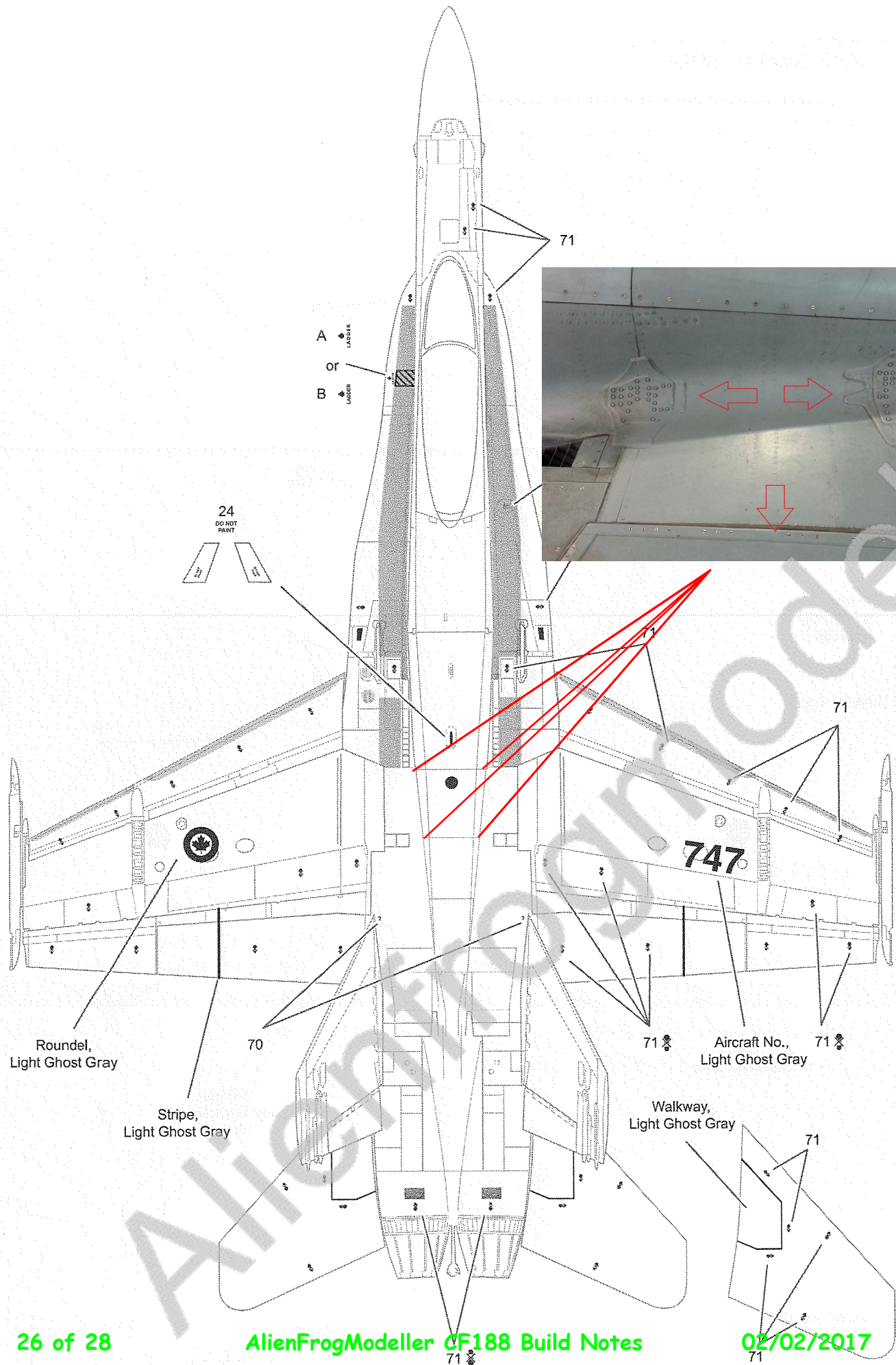



PAINT INDEX

COLOR	AMMO MIG	VALLEJO MODEL COLOR	GSI CREOS MR. COLOR	TAMIYA ENAMEL/ACRYLIC	HUMBROL ENAMEL
B RESEDAGRÜN	A.MIG-004	823	-	X05	2
DUNKELGELB AUS '44 DG I	A.MIG-011	830	-	XF62	66
PROTECTIVE GREEN	A.MIG-023	891	-	-	117
SAND BROWN	A.MIG-026	874	-	-	-
DESERT SAND	A.MIG-029	916	-	-	250
SAND YELLOW	A.MIG-030	887	304	XF72	155
SATIN BLACK	A.MIG-032	861	2	-	21
OLD WOOD	A.MIG-036	879	81	-	-
GUN METAL	A.MIG-045	863	76	XF56	53
MATT BLACK	A.MIG-046	950	12	XF1	33
SATIN WHITE	A.MIG-047	842	1	-	22
YELLOW	A.MIG-048	953	413	XF3	15
RED	A.MIG-049	957	H3 Gunze	XF07	153
MATT WHITE	A.MIG-050	951	11	XF2	34
BLUE	A.MIG-086	963	H5 Gunze	-	52
CRYSTAL RED	A.MIG-093	934	-	X27	220
CRYSTAL PERISCOPE GREEN	A.MIG-096	936	-	X25	-
CRYSTAL ORANGE	A.MIG-097	935	-	X26	-
CRYSTAL LIGHT BLUE	A.MIG-098	938	-	X23	-
SILVER	A.MIG-195	997	8	XF16	11
GOLD	A.MIG-198	996	9	X12	-
GHOST GRAY	A.MIG-208	991	317	XF54	27
LIGHT GRAY	A.MIG-209	990	308	-	-
GRAY BLUE	A.MIG-210	901	H337 Gunze	-	-
MEDIUM GRAY	A.MIG-211	989	-	XF19	127
INTERMEDIATE BLUE	A.MIG-228	867	36	XF54	79
OLIVE DRAB LIGHT BASE	A.MIG-927	893	309	XF27	91
RUSSIAN SHINE	A.MIG-935	838	-	-	-

Radome Tan

H318 Gunze

False Canopy Color - 36118 H305 Gunze

IP DECAL

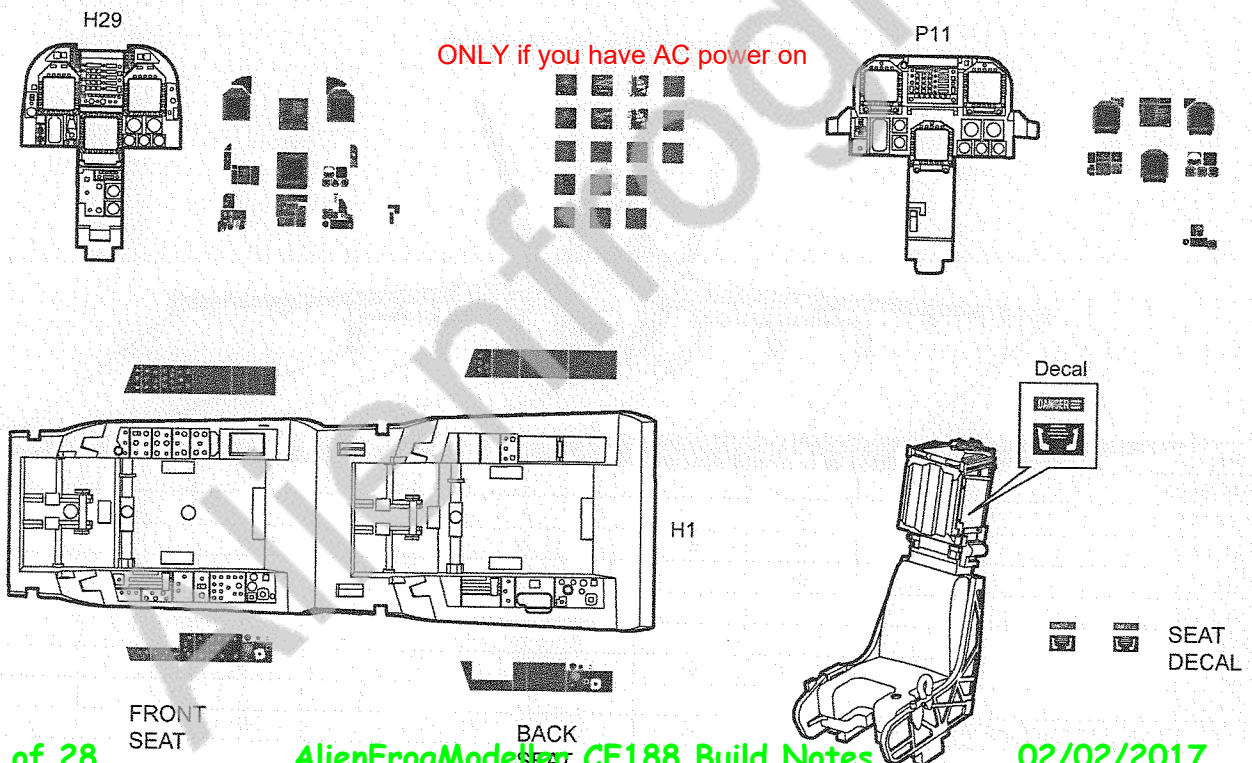

Painting & Decal Placement - External Stores

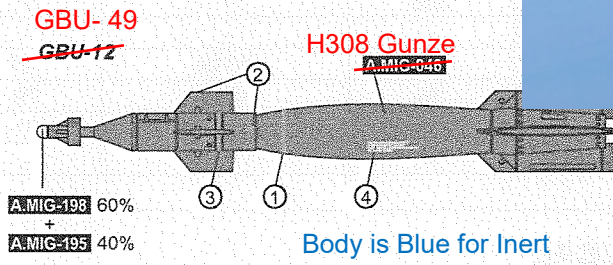
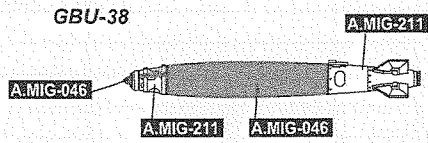
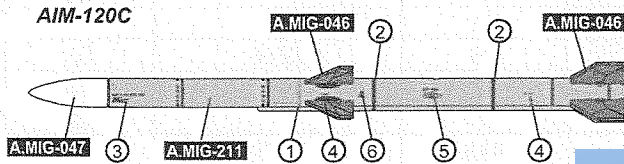
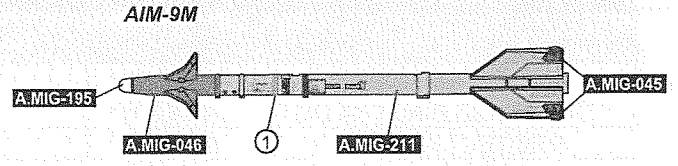
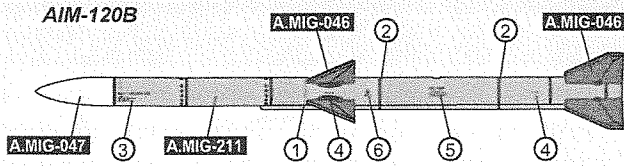

Body is Blue for Inert



EXTERNAL STORES

Typical Load for Op Impact in red
 Double the Stn load when BRU-55 installed on Stn 8 and/or 2 - do your research various loadouts were used.
 GBU-38 and GBU-49 weapons of choice

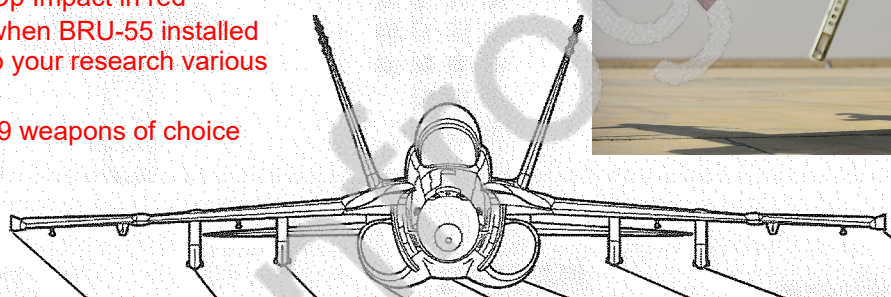

Weapons	Sta. No.	<9>	<8>	<7>	<6>	<5>	<4>	<3>	<2>	<1>
AIM-9MX		●								●
AIM-120					●		●		●	
GBU-12			●	●				●	●	
GBU-38			●						●	
AAQ-32							●			
AAQ-28 Op Impact	9	GBU-49	X	120	Tank	Sniper	Tank	GBU-49	9	
CBU-10	9	GBU-38	X	120	Tank	Sniper	Tank	GBU-38	9	
AAQ-38							●			
FUEL TANK 330 Gallons				●		●		●		