



## Horizontal Directional Drill Work Plan

Case 18-T-0604

August 2021

Prepared for:

South Fork Wind, LLC

Prepared by:

Mott MacDonald

**South Fork  
Wind**

Powered by  
Ørsted &  
Eversource

# HORIZONTAL DIRECTIONAL DRILL WORK PLAN

August 2021

## Table of Contents

<b>ABBREVIATIONS .....</b>	<b>ii</b>
<b>1.0 INTRODUCTION.....</b>	<b>1</b>
1.1 HDD SITE PREPARATION AND EQUIPMENT SETUP .....	2
1.2 HDD PILOT BORE OPERATIONS .....	3
1.3 OFFSHORE HDD SUPPORT.....	3
1.4 HDD REAMING OPERATION .....	4
1.5 HDD SWAB PASS / CLEANING PASS OPERATION .....	5
1.6 HDPE CONDUIT FABRICATION .....	5
1.7 HDD PULLBACK OPERATION .....	5
1.8 HDPE POST INSTALLATION VERIFICATION.....	6
1.9 COMPLETION AND SITE DEMOBILIZATION.....	6
<b>2.0 HDD DRILLING FLUIDS.....</b>	<b>7</b>
<b>LIST OF ATTACHMENTS</b>	
Attachment A HDD Landfall Installation Plan and Profile Drawings .....	A.1
Attachment B Dredging Work Plan .....	B.1
Attachment C Evaluation of the Efficacy of Alternative Cable Protection Measures at HDD Exit Pit .....	C.1
Attachment D Written Analysis of Alternative HDD Exit Pit Design .....	D.1

# HORIZONTAL DIRECTIONAL DRILL WORK PLAN

August 2021

## Abbreviations

Certificate	Certificate of Environmental Compatibility and Public Need
DPS	Department of Public Service
EM&CP	Environmental Management and Construction Plan
HDD	horizontal directional drill
HDPE	high-density polyethylene
ft	feet
in	inch
kV	kilovolt
m	meter
mm	millimeter
NYS	New York State
SFEC	South Fork Export Cable
SFW	South Fork Wind, LLC

# HORIZONTAL DIRECTIONAL DRILL WORK PLAN

August 2021

## 1.0 INTRODUCTION

South Fork Wind, LLC (SFW) will construct, operate, and maintain the South Fork Export Cable (SFEC) in support of the South Fork Wind Farm which will be constructed 35 miles (30 nautical miles, 56 kilometers) east of Montauk Point. The SFEC will be an alternating current electric cable (138 kilovolts [kV]) that will extend from the South Fork Wind Farm in federal offshore waters to coastal New York State (NYS) waters and inland to the existing mainland electric grid located in the Town of East Hampton, New York. This Horizontal Directional Drill (HDD) Work Plan is part of the Environmental Management and Construction Plan (EM&CP) for the SFEC components subject to Article VII of the New York Public Service Law, including the following, hereafter referred to as “the Project”:

- SFEC-NYS: the submarine segment of the export cable buried beneath the seabed from the boundary of NYS waters (three nautical miles offshore) to a sea-to-shore transition vault located in the Town of East Hampton on Long Island, Suffolk County, New York. The SFEC-NYS includes the sea-to-shore transition via HDD.
- SFEC-Onshore: the terrestrial underground segment of the export cable from the sea-to-shore transition vault to the SFEC-Interconnection Facility where the SFEC will interconnect with the Long Island Power Authority (LIPA) electric transmission and distribution system in the Town of East Hampton, New York.
- SFEC-Interconnection Facility: a new onshore facility, primarily consisting of a transformer and a 69 kV interconnection cable that will connect to the 69 kV bus in the existing LIPA East Hampton Substation in the Town of East Hampton, New York.

This Horizontal Directional Drilling (HDD) Work Plan has been prepared for the proposed HDD landfall installation of a high-density polyethylene (HDPE) conduit to house an electrical cable. This HDD Work Plan is intended to provide details of the anticipated HDD landfall based on site conditions. The specific HDD equipment required, often referred to as the ‘HDD spread’, will be dictated by the site conditions and may include, but is not limited to, the following:

- HDD rig
- Hydraulic power unit
- Mud pump
- Separation plant
- Generator
- Pump
- Excavator



## HORIZONTAL DIRECTIONAL DRILL WORK PLAN

August 2021

- Other equipment to facilitate drilling the borehole and stringing the pipe

It is expected that SFW will utilize up to a maximum of 6 temporary goal posts with an assumed spacing of 60-75 feet. The goal posts may be up to a total of 130 feet in length depending on the height of the jack-up barge. Each goal post consists typically of two vertically installed hollow steel pipes or H-beams with a cross brace including a roller for the approximately 60 inch (in; 152 centimeter [cm]) diameter casing pipe. The diameter of each goal post may be up to 30 inches (76 cm) based on the actual weight of the casing pipe. The installation of the goal posts is expected to be performed by impact or vibratory pile driving to a depth of up to 25 feet (ft; 7.6 meters [m]). The goal posts will be removed at the conclusion of HDD works by pull back and/or vibratory removal methods.

The proposed HDD entry location is situated onshore within the road right-of-way of Beach Lane in East Hampton, New York (refer to Attachment A). The width of the Beach Lane road right-of-way is 49.5 ft ( 15.1 m). The proposed HDD exit location is situated offshore in the Atlantic Ocean. **The outer diameter of the HDPE conduit will be approximately 26 to 28 in (66 to 71 cm).**

The HDD Plan and Profile drawings are provided in Attachment A. The proposed HDD profile is subject to change as drilling progresses but will comply with minimum depth requirements contained in the Certificate of Environmental Compatibility and Public Need (Certificate). The horizontal HDD installation length considered within this evaluation is approximately 2,550 ft (777 m). Both the HDD entry and exit locations meet the requirements of the Certificate.

The elevations of the HDD entry and exit locations will be approximately 11.3 and -26.8 ft (3.4 and -8.2 m), respectively. An elevation difference of approximately 49 ft (15 m) exists between the HDD entry and exit locations, with the entry location at the higher elevation. The designed depth of the HDD installation beneath the seabed, at its shallowest, will be approximately 80 ft (24.4 m) with the exception of the exit curve, where the HDD bore profile begins to ascend towards the ocean floor. A jack-up barge or similar will be used to support drilling operations offshore at the HDD exit location.

Temporary casing pipes are anticipated at both the HDD entry and exit locations. The onshore casing pipe is anticipated to be approximately 125 ft (38 m) in length. The offshore casing pipe is anticipated to be approximately 320 ft (98 m) in length. The offshore casing pipe will be seated into the ocean floor from the jack-up barge at the exit location upon completion of the pilot bore drilling operation and will be used to maintain an open pathway for capturing drilling fluid flow. Due to its length, several goalposts will be installed to help support the casing pipe at this location. The goalposts will be driven into the seafloor to provide vertical support for the casing pipe. Upon completion of the HDD operation, the goalposts and casing pipe will be removed from the seafloor.

The Contractor(s), once appointed, together with Orsted shall hold a risk review session to further identify, assess and determine appropriate controls for key risks. SFW completed a risk analysis of the scope of work to identify erosion and sediment controls and mitigation practices.

### 1.1 HDD SITE PREPARATION AND EQUIPMENT SETUP

The onshore workspaces will be prepared for mobilization and setup of the drilling equipment. At the HDD entry location, utilities (both above and below ground) and a fire hydrant will be relocated, and vegetation removed, if necessary, to accommodate the access lane (refer to Appendix E – Vegetation Management

## **HORIZONTAL DIRECTIONAL DRILL WORK PLAN**

August 2021

Plan to the EM&CP for additional information on vegetation removal). A sound wall and jersey barriers will be erected along the west side of the workspace. Privacy fencing with sound absorbing material will be installed on the east side and gates with privacy fencing will be installed on the north and south sides of the enclosed workspace. A schematic of the workspace showing anticipated equipment setup is provided in Attachment A. Once the HDD equipment has been set up at the HDD entry location, a large diameter starter/conductor casing will be installed. This casing will be used to help support the shallow soils and provide an open bore path for drilling fluid flow to the HDD entry location. This casing will be up to 60 in (1,524 mm) in diameter. As stated earlier, the onshore conductor casing pipe length is expected to be approximately 125 ft (38 m). A pneumatic hammer, or similar method, will be used to install this casing pipe.

An onshore anchor will be installed to allow the drill rig to generate the required thrust and pull back force to complete all drilling stages. The anchor is expected to be made of steel sheet piles, driven into the ground perpendicular to the drilling alignment. For the offshore HDD drilling spread, the weight of the jack-up barge or the offshore casing pipe and goal posts will be used to generate the pull force necessary to support drilling operations.

### **1.2 HDD PILOT BORE OPERATIONS**

The pilot bore stage consists of advancing a steerable drill bit along the design alignment from the HDD entry location onshore to the target exit location offshore.

Given that the completed geotechnical investigation indicates soils will be primarily sand with some silt, a jetting assembly will likely be used to complete the pilot bore installation. Steering of the jetting assembly is accomplished using an asymmetrical bent sub positioned behind the drill bit. Steering reactions are achieved by generating a steering bias with proper orientation of the bent sub and thrusting the drill bit assembly forward with the drill rig without any rotation of the drill pipe. During this process, the advancement of the drill bit without rotation generates a passive resistance within the soil that acts on the leading surface of the drill bit to induce a direction change. When steering is not needed, the drill pipe is rotated while the drill rig advances the drill bit along the alignment.

The three-dimensional location of the drill bit is tracked as the pilot bore is advanced. The tracking system allows for any steering corrections to be made. Once the pilot bore is completed, the drilling assembly is removed and replaced with a reaming assembly to enlarge the bore hole diameter. Tracking information will be collected and will include elevation, alignment, distance away from entry, inclination, and azimuth.

### **1.3 OFFSHORE HDD SUPPORT**

A marine spread including a jack-up barge or similar vessel together with support vessels will be mobilized to the HDD exit location and will perform dredging operations to allow for burial of the HDPE conduit after installation. Details of the anticipated excavation are shown in Attachment A.

Excavation of the exit pit will be accomplished using a sealed environmental bucket such as a clam shell bucket. All removed material will be brought to the surface for transfer to a work barge for visual inspection and storage. Excavated material will not be side-cast. Excavation work will be performed to limit turbidity within the ocean environment. The excavation may be temporarily filled with rock bags lowered into position

## HORIZONTAL DIRECTIONAL DRILL WORK PLAN

August 2021

from the support barge, to limit the excavation from naturally backfilling during the HDD operation. The majority of the rock bags will be removed once the HDPE conduit is installed and tested, where deemed necessary to ensure the full extent of the exit pit remains open during construction (thereby minimizing the need for future re-excavation). A number of rock bags may be left in place until the cable is installed, which is expected to take place during the same construction season. In the event natural backfilling of the HDD exit pit occurs, maintenance may be required to ensure the full extent of the exit pit remains open during construction. Refer to Attachment B for additional information on dredging methods and clamshell bucket drawings and specifications.

Upon completion of the pilot bore operations, a large-diameter conductor casing will be installed from the jack-up barge, over the drill pipe, and will protrude from the deck of the barge down into the ocean floor sediments. The casing pipe will be centered over the drill pipe used to complete the pilot bore stage of the installation process. The casing will be advanced a sufficient depth into the ocean floor to provide a seal around the casing pipe to help manage and control drilling fluid flow. The casing will also be used to provide an open-flow pathway for drilling fluids and an access path to the HDD bore. A pneumatic hammer is anticipated to be used to install this casing pipe. Goal post/steel piles will be installed to support the casing pipe within the water. The offshore arrangement is depicted in Attachment A.

Once installed, the offshore conductor casing will allow collection of drilling fluids on the deck of the jack-up barge, limiting losses to the ocean environment. Fluids will either be processed offshore and reused for drilling operations or collected and stored for processing and disposal at a later date.

### 1.4 HDD REAMING OPERATION

After completion of the pilot drilling, the bore is enlarged by 'reaming' to ensure the bore is sufficiently sized to accommodate safe passage of the HDPE conduit. Given the diameter of the HDPE conduit of approximately 26 to 28 in (66 to 71 cm), at least two passes with reamers of increasing diameter will be passed through the bore to incrementally enlarge the pilot bore to its final diameter.

Selection of the reamer and the reaming strategy are dependent on geotechnical data and information gathered during the pilot bore process. Reaming tools are customarily attached to the drill string at the HDD entry location and pushed out towards the exit location. This reaming direction is commonly referred to as a forward ream and is used to promote drilling fluid flow to the onshore HDD location. The HDD drilling operation will utilize a continuous pipe string which requires the addition or removal of drill pipe to the drill string. A second HDD equipment spread will be setup on the jack-up barge. This drill rig will be used to anchor the drill string and support the reaming process. It will also be used to add/remove drill pipe from the drill pipe string as the reamers are returned to the onshore rig location. The onshore drill will work in tandem with the offshore rig to advance tooling.

The final bore diameter will be at least 12 in (30.5 cm) larger than the outer diameter of the product pipe, in this case the conduit. A final bore diameter of 42 in (107 cm) is expected to comply with the 12 in (30.5 cm) larger requirement and use of standard tool sizes.

## **HORIZONTAL DIRECTIONAL DRILL WORK PLAN**

August 2021

### **1.5 HDD SWAB PASS / CLEANING PASS OPERATION**

Upon completion of the reaming passes, the condition of the HDD bore will be assessed by completing a swab pass. The swab pass consists of pushing or pulling a slightly smaller diameter barrel or ball reamer through the fully reamed bore from start to finish in the direction of the offshore to onshore installation. During the swab pass, drill rig torque and thrust/pullback force are monitored. If the swab pass is completed with little drill rig effort, the bore is deemed to be conditioned properly to accept the conduit for installation. However, if areas of high torque or thrust/pullback forces are observed, the bore may not be ready for conduit installation and the bore may require an additional reaming pass or passes. Once remedial reaming measures are completed, if necessary, subsequent swab passes will be completed to ensure the areas of high drill rig effort have been reduced or eliminated.

### **1.6 HDPE CONDUIT FABRICATION**

Prior to installation, the HDPE conduit will be fabricated into a single pipe string via welding. When the pipe string is fully fabricated, an air pressure test will be completed to verify integrity of the welding process. In addition, a calibration tool including a gauging plate sized to an average of 90 percent of the inner diameter of the HDPE conduit will be passed through the conduit to confirm its condition prior to installation.

### **1.7 HDD PULLBACK OPERATION**

The final stage of the installation process consists of connecting the HDPE conduit with the pullback assembly and then pulling the conduit into the bore from offshore towards onshore using the onshore HDD drill rig.

The HDPE conduit will be transported/towed to the HDD exit location offshore. The front end of the pipe will consist of a closed pulling head which prevents any fluids or cuttings from entering the HDPE conduit during installation. A swivel connection will be used to connect the HDPE conduit string to the pull back assembly. Generally, a reamer that is slightly larger than the pipe diameter, but smaller than the completed bore diameter, is attached to the drill string in front of the conduit. The swivel connection allows the drill string to rotate the reamer without rotating the conduit, thus reducing torsional stresses on the conduit. This helps clear any cuttings that may remain in the bore and reduces the risk to the conduit during installation. The use of the reamer also allows for fluids to be pumped downhole during pullback for lubrication to assist the conduit pulling operation.

HDPE pipe is buoyant even when filled with water. To counteract the buoyancy force and reduce the frictional loads that can develop during the pullback operation, water will be added to the conduit interior as it is installed or prior to installation.

As the HDPE conduit is installed, it will displace a volume of drilling fluids and cuttings from within the HDD bore. Initially, these fluids will flow towards the offshore exit location and eventually shift towards the onshore HDD entry location. The presence of the offshore conductor casing will allow for collection, processing, and storage of the displaced drilling fluids on the jack-up barge or a secondary work barge.

## **HORIZONTAL DIRECTIONAL DRILL WORK PLAN**

August 2021

The presence of the casing pipe will significantly reduce the potential for drilling fluid losses to the ocean environment.

### **1.8 HDPE POST INSTALLATION VERIFICATION**

Once the HDPE conduit is installed, testing will be completed to verify the condition of the pipe. This will involve calibration of the pipe with a gauging plate equal to 90 percent of the average inner diameter of the HDPE conduit. At the same time the calibration tool is advanced through the pipe, a messenger rope will be installed for the cable pull in operation.

### **1.9 COMPLETION AND SITE DEMOBILIZATION**

The conductor casings installed to facilitate the installation process will be removed following completion of conduit installation. The pneumatic hammer that was used to install the casing pipes will be used to remove them. The equipment spread onshore will be demobilized. Any rock bags that remained in the exit pit, except rock bags or other cable protection that will be permanent to weigh down and protect the conduit end and cable interface, will be removed.

The HDPE conduit end will be lowered to the seafloor and buried beneath the seafloor a minimum of 6 ft (1.8 m). These details are provided in the drawing package included in Attachment A. Permanent concrete mattresses or other cable protection described in Attachment C will be used to weigh down and protect the HDPE conduit within the HDD exit location. The conduit protection will be buried with at least 3 ft (0.9 m) of cover.

Final backfill of the HDD exit pit, ensuring no discernible trough, shall be performed no later than three months following the Project's Commercial Operation Date. Prior to final backfill, the exit pit may be partially backfilled while maintaining open access to the conduit end and the surrounding area within the exit pit for the offshore cable installation contractor.

No contaminated material will be used for backfilling purposes. Any excavated material that is not contaminated and not used for backfill will be disposed of at an approved disposal location. The disposal location will be submitted to NYS Department of Public Service Staff (DPS Staff), the Town of East Hampton, Trustees, and NYS Department of Environmental Conservation at least 30 days prior to disposal. Disposal of all material will comply with Title 6 of the New York Codes, Rules and Regulation Part 360. Once the location and position of the HDPE conduit has been surveyed, the HDD marine spread will be demobilized.

# HORIZONTAL DIRECTIONAL DRILL WORK PLAN

August 2021

## 2.0 HDD DRILLING FLUIDS

Drilling fluids are used during all HDD drilling phases. Drilling fluids provide several functions integral to the success of the installation. The primary functions include:

- Cooling and lubricating drilling tools, drill pipe, and the conduit;
- Suspension of cuttings within the drilling fluid/slurry mixture;
- Removal of soil cuttings from the bore during each phase of the installation process; and
- Stabilization of the bore and prevention of raveling of surrounding soil/bedrock materials. Stabilization of the bore is provided by the combination of developing a low-permeability bentonite filter cake against the bore walls and applying a positive fluid pressure to the surrounding bore walls. The supporting pressure is derived from the presence of the column of drilling fluid within the bore.

The drilling fluids are water-based and consist of a mixture of water, bentonite and/or additives. Bentonite is a naturally occurring, non-toxic, inert material that meets National Sanitation Foundation/American National Standards Institute (NSF/ANSI) 60 Drinking Water Additive Standards and is used in portable water wells. Soda ash is used to raise the pH of the drilling fluid above 8 for maximum bentonite yield. Soda ash meets NSF/ANSI-60 Drinking Water Additive Standards. The exact fluid mixture will be determined based on the anticipated and actual geotechnical materials encountered within the bore and the performance of the drilling equipment as the drilling process progresses. Additives are commonly used to modify specific drilling fluid properties that bentonite alone is not capable of providing. The brand and manufacturer of the bentonite, soda ash and additives will be provided to DPS Staff for review prior to construction, and the NYS Department of Environmental Conservation (NYSDEC) will also be notified. If polymer-based additives are proposed to be used, an approved NYSDEC Water Treatment Chemical Form will be provided in addition to the Safety Data Sheets and eco-toxicity information to NYS Department of Public Service Staff (DPS Staff) for approval. Petroleum-based additives will not be used. A typical drilling fluid consists of 95 percent water, 4 percent bentonite, and less than 1 percent additives. Several Safety Data Sheets and eco-toxicity information of the drilling fluid components for various drilling fluid additives are provided in Attachment C of the Inadvertent Returns Plan (Appendix J to the EM&CP). Once the HDD -Contractor has been selected, the drilling fluid components will be updated/revised and, if necessary, additional Safety Data Sheets will be provided early in the preconstruction phase for review and approval by DPS Staff in consultation with NYS Department of Environmental Conservation.

The drilling fluid will be mixed in a mud mixing tank that is part of the separation plant/reclaimer. Soda ash, bentonite, and additives will be added to the mixing tank in accordance with manufacturer's recommendation.

Once the drilling fluids are thoroughly mixed, they will be pumped downhole through the drill pipe and out of the drill bit or reaming assembly where they will mix with the soil cuttings generated by the tooling. The drilling fluids and cuttings mixture will flow under an induced fluid pressure gradient generated by the

## **HORIZONTAL DIRECTIONAL DRILL WORK PLAN**

August 2021

injection of additional drilling fluids into the bore following the path of least resistance. The drilling fluid/slurry mixture will flow toward either the HDD entry or exit locations depending on which stage of the installation process is being completed and the proximity of the down-hole tooling in relation to these locations.

The returning drilling fluid/slurry mixture is collected at the HDD entry and/or exit locations and transferred to a separation plant for processing. The separation plant allows for separation of the soil cuttings and reuse of the water component for additional drilling.

Attachment D includes a written analysis of alternative HDD exit pit design considered. The design depth of the proposed HDD profile has been selected to limit the potential for inadvertent returns. An appropriate depth of cover provides sufficient overlying strength to resist the required fluid pressures and modifying pump rates to match advance rates during exiting of the pilot bore. However, all HDD installations inherently carry a risk of an inadvertent drilling fluid return. The Inadvertent Returns Plan, included as Appendix J to the EM&CP, outlines SFW's responsibilities, protocols, and required notifications in the event of an inadvertent drilling fluid return during HDD operations.

A Final Hazardous Waste and Petroleum Work Plan (Appendix H to the EM&CP) has also been developed to discuss the handling of drilling fluids, separated spoils, and contaminated materials.

# HORIZONTAL DIRECTIONAL DRILL WORK PLAN

August 2021

## **ATTACHMENTS**



**HORIZONTAL DIRECTIONAL DRILL WORK PLAN**

August 2021

**Attachment A HDD LANDFALL INSTALLATION PLAN AND  
PROFILE DRAWINGS**

# SOUTH FORK WIND PROJECT - ORSTED & EVERSOURCE HDD LANDFALL INSTALLATION

ENGINEERING FIRM: MOTT MACDONALD  
SUFFOLK COUNTY, NEW YORK

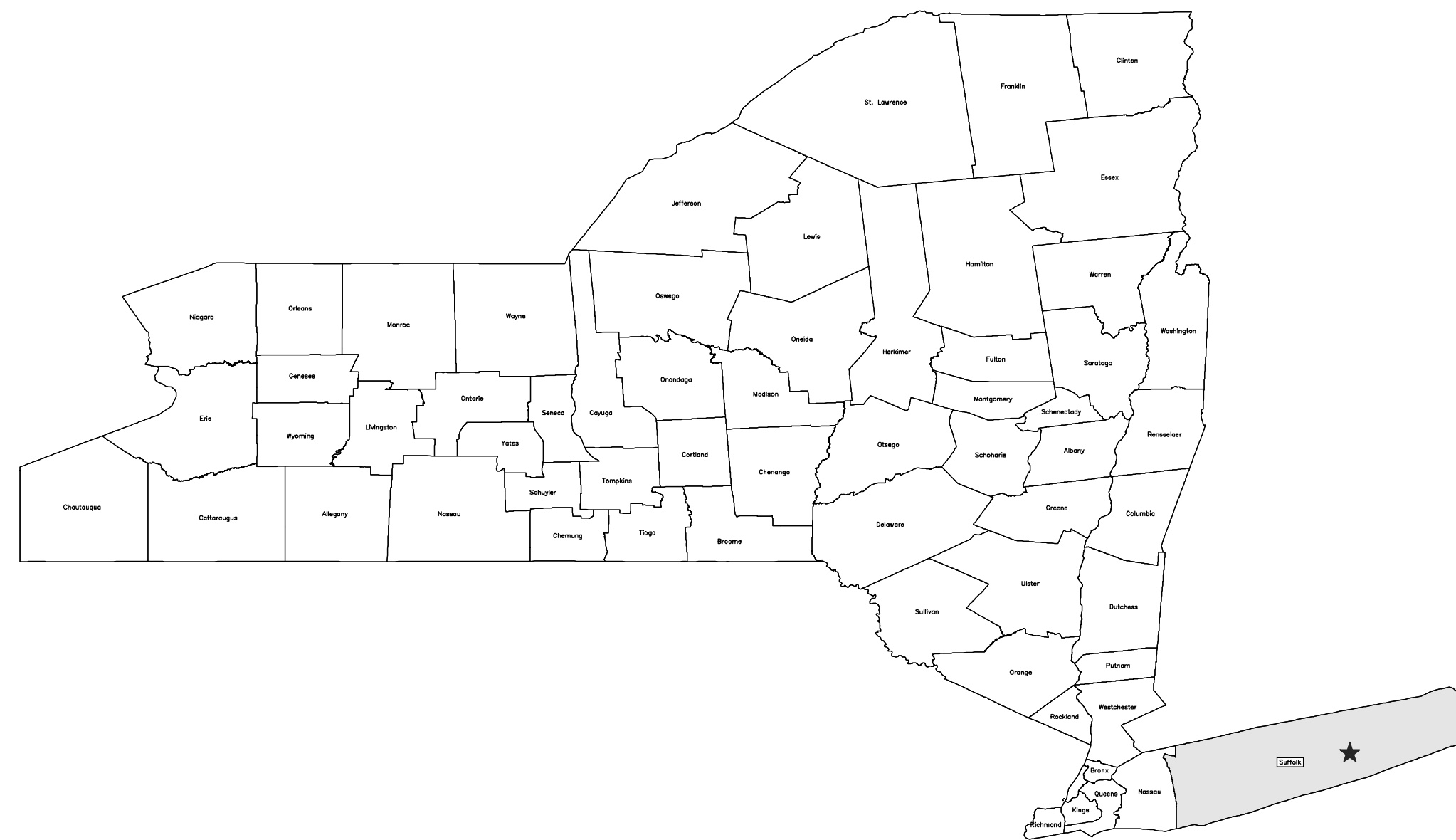

PROJECT LOCATION:  
SUFFOLK COUNTY, NEW YORK

DRAWING LIST		
DWG. No.	TITLE	REV.
#SFW01=X01AAE&ELD001	COVER SHEET	E
#SFW01=X01AAE&ELD002	SHEET INDEX	E
#SFW01=X01AAE&ELD003	HDD PLAN & PROFILE	E
#SFW01=X01AAE&ELD004	WORKSPACE DRAWING	F
#SFW01=X01AAE&ELD005	EXCAVATION DETAIL	E

E	06/30/21	GD	CAC	ISSUE FOR TENDER
D	03/22/21	GD	CAC	ISSUED FOR PERMIT
C	10/22/20	GD	CAC	UPDATED DRAFT FOR REVIEW
B	09/11/20	GD	CAC	ISSUED FOR 60% REVIEW
A	07/31/20	GD	CAC	ISSUED FOR 30% REVIEW
Rev.	Date	Accep.	Appr.	Description
Drawn by		Accepted	Approved	
Scale	Size	Sheet Document No.		
1" = 20'	D-SIZE	06566419		
Supplier	Supplier Document No.			

*Chris*  
07/28/2021



CONTRACTOR  
**M M**  
MOTT MACDONALD  
MOTT MACDONALD NY INC.  
111 Wood Avenue South  
Iselin, NJ 08830-4112  
Certificate of Authorization #: 0017019

**South Fork Wind**  
Powered by Ørsted & Eversource  
ORSTED  
COVER SHEET  
VERSION 1  
SUFFOLK, NEW YORK  
DRAWING NUMBER:  
#SFW01=X01AAE&ELD001



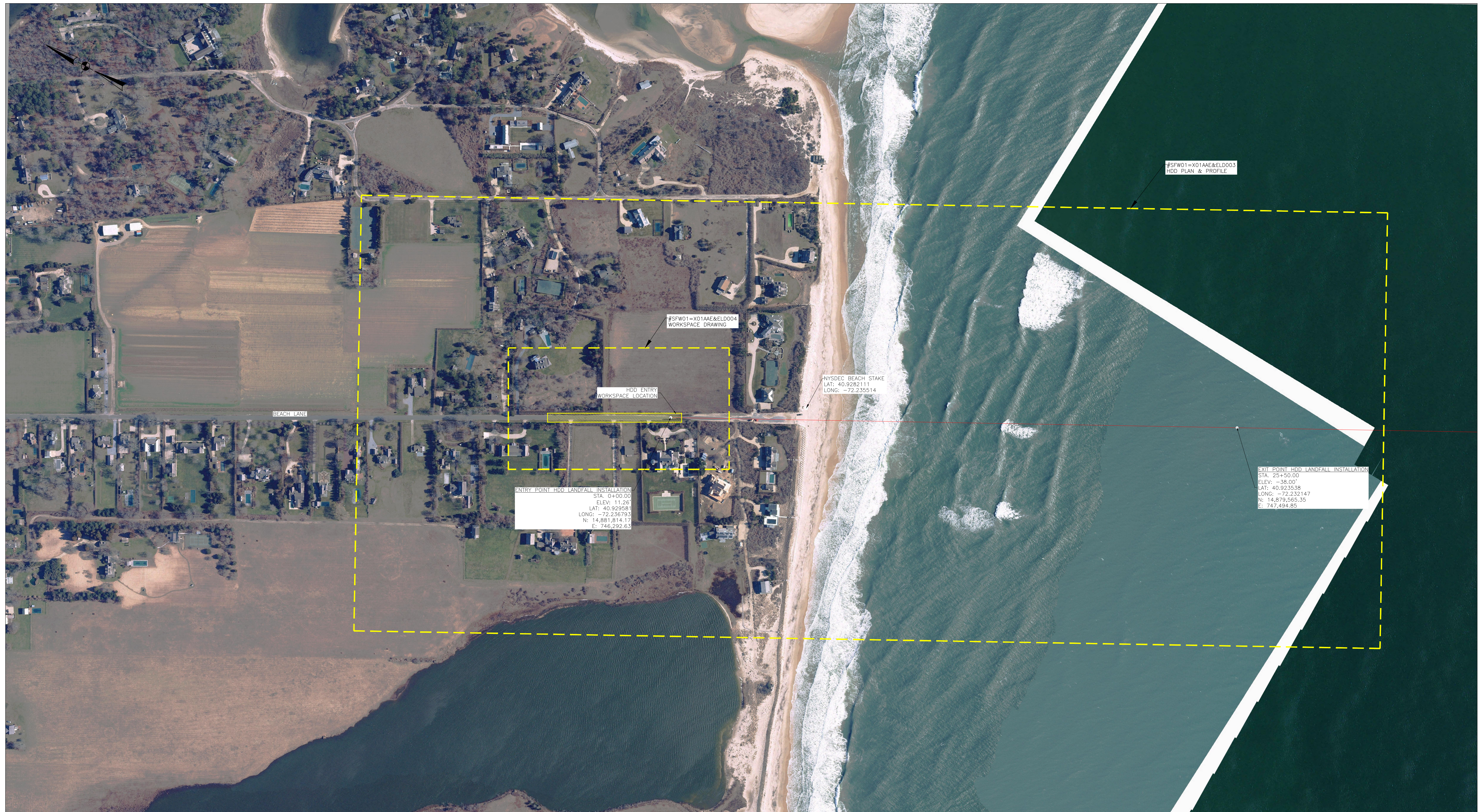

ENTRY POINT HDD LANDFALL INSTALLATION  
 STA: 0+00.00  
 ELEV: 11.26'  
 LAT: 40.929581  
 LONG: -72.236793  
 N: 14,861,814.17  
 E: 746,292.63

HDD ENTRY  
 WORKSPACE LOCATION

#SFW01=X01AAE&ELD004  
 WORKSPACE DRAWING

NYSDEC BEACH STAKE  
 LAT: 40.9282111  
 LONG: -72.235514

#SFW01=X01AAE&ELD003  
 HDD PLAN & PROFILE

EXIT POINT HDD LANDFALL INSTALLATION  
 STA: 25+50.00  
 ELEV: -38.00'  
 LAT: 40.923538  
 LONG: -72.232147  
 N: 14,879,565.35  
 E: 747,494.85

E	06/30/21	GD	CAC	ISSUE FOR TENDER
D	03/22/21	GD	CAC	ISSUED FOR PERMIT
C	10/22/20	GD	CAC	UPDATED DRAFT FOR REVIEW
B	09/11/20	GD	CAC	ISSUED FOR 60% REVIEW
A	07/31/20	GD	CAC	ISSUED FOR 30% REVIEW

Drawn by	Accepted	Approved
07/31/2020RJR	07/31/20 GD	07/31/20 CAC
Scale	Size	Printed Document No.
1" = 20'	D-SIZE	06566419

Supplier: South Fork Wind  
 Supplier Document No.: Powered by Ørsted & Eversource

*Chris*  
 06/30/2021



CONTRACTOR  
**M**  
**MOTT**  
**MACDONALD**  
 MOTT MACDONALD NY INC.  
 111 Wood Avenue South  
 Iselin, NJ 08830-4112  
 Certificate of Authorization #: 0017019

ORSTED  
 SHEET INDEX  
 VERSION 1  
 SUFFOLK, NEW YORK  
 DRAWING NUMBER:  
 #SFW01=X01AAE&ELD002



SUFFOLK, NEW YORK

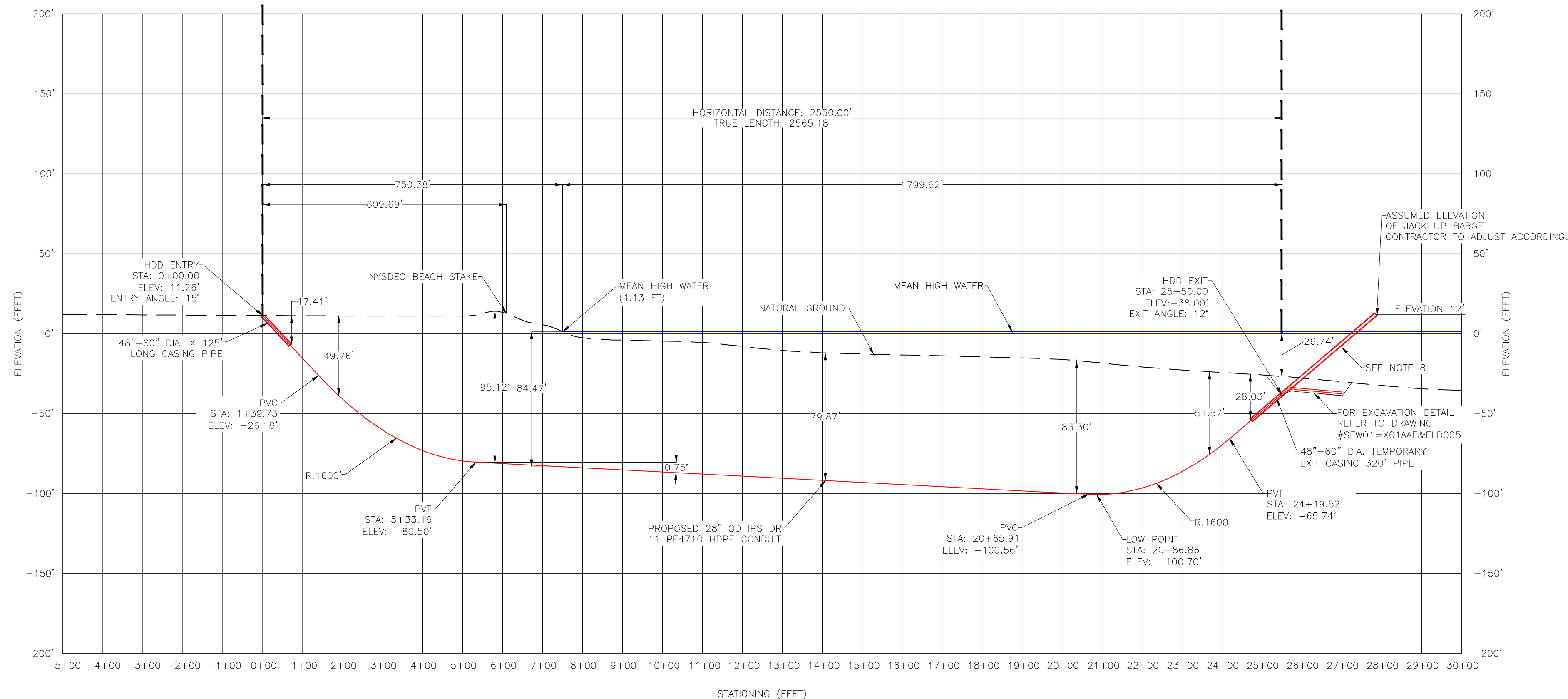
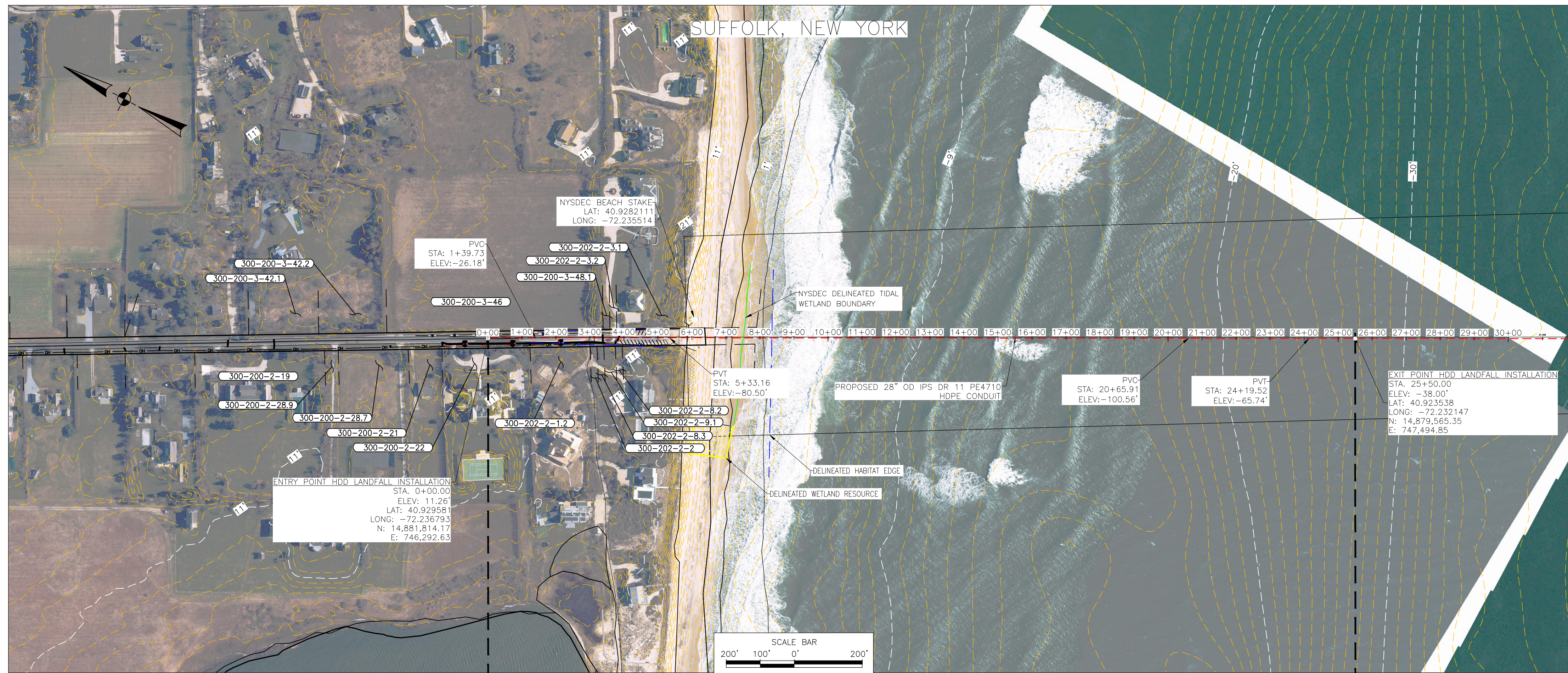

PROFILE  
 HORIZ. SCALE: 1"=200'  
 VERT. SCALE: 1"=50'

LEGEND:

PROPOSED HDPE CONDUIT	ACCESS ROAD	DELINEATED HABITAT EDGE
PROPERTY LINE	ROAD R.O.W.	DELINEATED WETLAND RESOURCE
MINOR CONTOUR	EXISTING FENCE	
MINOR CONTOUR	NYSDEC DELINEATED TIDAL WETLAND BOUNDARY	

CROSSING SPECIFIC HDD NOTES:

- ALL EQUIPMENT SHALL BE STAGED WITHIN THE IDENTIFIED WORK SPACE.
- ALL ELEVATIONS ARE REFERENCED TO NAVD88 (0.00'). 0.00' NAVD88 = -1.78' MLLW, -1.66' MLW, +1.13' MHW, AND +2.59' HTL (BASED N HIGHEST ASTRONOMICAL TIDE).
- DIMENSIONS PROVIDED ON THE DRAWING ARE IN FEET, UNLESS OTHERWISE NOTED.
- ALL CHAINAGES ARE HORIZONTAL.
- METHOD OF HDPE CONDUIT INSTALLATION SHALL BE BY HORIZONTAL DIRECTIONAL DRILL.
- CONTRACTOR SHALL DETERMINE FINAL LOCATIONS AND DIMENSIONS OF ALL MUD PITS NECESSARY TO ACCOMMODATE THEIR MEANS AND METHODS.
- IT IS THE CONTRACTOR'S RESPONSIBILITY TO IDENTIFY AND PROTECT ANY FOREIGN UTILITY THAT MAY BE AFFECTED BY THE OPERATIONS. EXISTING UTILITY LOCATIONS AND DEPTHS, INCLUDING PRIVATE SERVICES, ARE APPROXIMATE AND SHALL BE FIELD VERIFIED BY THE CONTRACTOR PRIOR TO ANY CONSTRUCTION OPERATIONS. CONTRACTOR TO STAGE ALL PERSONNEL AND EQUIPMENT WITHIN THE PERMITTED LIMIT OF DISTURBANCE AS DEPICTED ON THIS DRAWING, UNLESS OTHERWISE AUTHORIZED BY THE CLIENT.
- CONTRACTOR SHALL DETERMINE DIAMETER, GRADE WALL THICKNESS AND ANY ADDITIONAL LENGTH OF THE TEMPORARY CONDUCTOR CASING. ANY INSTALLED TEMPORARY CONDUCTOR CASING AND OFFSHORE GOAL POST SHALL BE FULLY REMOVED UPON COMPLETION OF PULLBACK OPERATIONS. CONTRACTOR TO DETERMINE OFFSHORE GOAL POST SUPPORTS NECESSARY FOR SUPPORTING THE CASING PIPE.
- HDD EXIT POINT IS LOCATED WITHIN AN EXCAVATION. THIS EXCAVATION WILL HELP ACHIEVE THE REQUIRED BURIAL DEPTH OF THE HDPE CONDUIT. DEPTH AND EXTENT OF EXCAVATION SHOWN ON DRAWINGS SUBJECT TO CHANGE. CONTRACTOR SHALL EXCAVATE THE EXIT PIT PRIOR TO PUNCHING OUT WITH THE PILOT BORE. SEE DRAWING #SFW01=X01AAE&ELD005 FOR EXCAVATION DETAILS.
- APPROXIMATE EXIT PIT LOCATION MAY INCLUDE TEMPORARY SUPPORT STRUCTURES. TEMPORARY SUPPORT STRUCTURES INCLUDING BUT NOT LIMITED TO CONDUIT SUPPORT PILES AND SECONDARY PROTECTION MAY BE INSTALLED AT THE EXIT PIT LOCATION TO AID IN THE INSTALLATION OF THE HDD. THESE FEATURES WILL BE REMOVED UPON COMPLETION OF THE CABLE INSTALLATION.
- THE INITIAL EXIT PIT EXCAVATION SHALL BE CONDUCTED WITH AN ENVIRONMENTAL CLAMSHELL BUCKET. DREDGED SEDIMENT SHALL BE PLACED IN A HOPPER SCOW(S) OR SIMILAR FOR TEMPORARY STORAGE. THE SCOW(S) MAY REQUIRE OCCASIONAL DECANTING TO REMOVE EXCESS WATER DURING DREDGING OPERATIONS. UPON COMPLETION OF THE HDD INSTALLATION, THE DREDGED SEDIMENT SHALL BE USED TO BACKFILL AND RESTORE THE EXIT PIT TO ITS PRE-EXCAVATION CONDITIONS. THE DREDGED SEDIMENT SHALL BE ANALYZED FOR CONTAMINATION PRIOR TO USE AS BACKFILL. SHOULD THE SEDIMENT BE DETERMINED UNSUITABLE FOR PLACEMENT, THE SEDIMENT SHALL BE DISPOSED OF AT A NYSDEC AUTHORIZED UPLAND DISPOSAL FACILITY OR ALTERNATIVE WITH APPROPRIATE APPROVALS. IF ADDITIONAL FILL IS NECESSARY TO RESTORE THE AREA TO ITS PRE-EXCAVATED CONDITIONS, CLEAN FILL OR SIMILAR GRAINSIZE SHALL BE ACQUIRED FROM AN UPLAND SOURCE AND PLACED AS BACKFILL.
- STEEL CASING AT EXIT LOCATION SHALL BE INSTALLED OVER THE DRILL PIPE ONCE THE PILOT BORE HAS BEEN COMPLETED.
- THE MINIMUM ALLOWABLE DRILLING RADIUS SHALL BE 900 FEET BASED ON A 3-JOINT AVERAGE.
- HDD OPERATIONS SHALL BE CONDUCTED IN ACCORDANCE WITH ALL PERMIT REQUIREMENTS.
- DOWNHOLE ANNUAL DRILLING FLUID PRESSURES SHALL BE MONITORED AT ALL TIMES DURING THE PILOT BORE DRILLING PROCESS. LOCATION OF MONITORING SHALL BE AS CLOSE TO THE DRILL BIT AS POSSIBLE. CONTRACTOR SHALL MAINTAIN FLUID PRESSURES AS LOW AS POSSIBLE AND REACT TO CLEAN THE BORE SHOULD FLUID PRESSURES DIFFER FROM CALCULATED VALUES.
- PILOT BORE SHALL BE CONTINUOUSLY TRACKED AT ALL TIMES. NO BLIND SECTIONS SHALL BE PERMITTED, EVEN WHEN THE DRILL BIT IS UNDER WATER.
- ROCK BAGS OR EQUIVALENT MAY BE TEMPORARILY PLACED WITHIN EXCAVATION TO PREVENT INFILLING DURING HDD OPERATIONS.
- PRIOR TO CABLE PULL IN, THE DREDGED AREA AT THE END OF THE HDPE CONDUIT MAY REQUIRE TARGETED REMOVAL/CLEARING OF ACCUMULATED SEDIMENT DUE TO INFILLING. TO AVOID DAMAGING THE CONDUIT, THIS WORK SHALL BE CONDUCTED WITH THE USE OF AN AIRLIFT, CONTROLLED FLOW EXCAVATION, AND/OR SUCTION DREDGING OR SIMILAR EQUIPMENT.
- SOIL IN VICINITY OF THE HDD ENTRY LOCATION SHALL BE COMPACTED FOLLOWING COMPLETION OF HDD OPERATIONS TO AVOID FUTURE SETTLEMENT.
- SPILL-PREVENTION: REFUELING OF ALL EQUIPMENT SHALL BE COMPLETED IN ACCORDANCE WITH CONTRACTORS JOB SAFETY PLAN.
- THE HDPE CONDUIT SHALL BE FABRICATED WITHIN THE APPROVED PRODUCT PIPE STRINGING AND FABRICATION AREA.
- HDPE CONDUIT SHALL BE INTERNALLY AND EXTERNALLY DEBEADED AS IT IS FABRICATED.
- PRE-INSTALLATION LOW PRESSURE AIR TEST AND MANDREL TEST SIZED TO 90% OF THE HDPE CONDUIT INTERNAL DIAMETER SHALL BE COMPLETED PRIOR TO TOWING TO HDD EXIT LOCATION. MANDREL TEST SHALL CONSIST OF BI-DIRECTIONAL CALIBRATION PIG COMPRISING OF GAUGING PLATES.
- POST-INSTALLATION MANDREL TEST SIZED TO 90% OF THE HDPE CONDUIT DIAMETER SHALL BE COMPLETED. MANDREL TEST SHALL CONSIST OF A BI-DIRECTIONAL CALIBRATION PIG COMPRISING OF GAUGING PLATES. DURING MANDREL TEST, CONTRACTOR SHALL INSTALL MESSENGER ROPE WITHIN THE HDPE CONDUIT.
- CONTRACTOR SHALL FULLY FILL THE HDPE CONDUIT WITH WATER DURING PULLBACK OPERATIONS. CONDUIT TO BE LEFT FULL OF WATER.
- EROSION AND SEDIMENT CONTROL: CONTRACTOR SHALL SUPPLY, INSTALL AND MAINTAIN SEDIMENT CONTROL STRUCTURES IN ACCORDANCE WITH STORM WATER POLLUTION PREVENTION PLAN.
- CLEANUP / STABILIZATION / RESTORATION: ALL DISTURBED AREAS ON SHORE SHALL BE RETURNED TO THE ORIGINAL CONTOURS. DISTURBED AREAS SHALL BE RETURNED TO ORIGINAL CONDITION OR BETTER.
- AERIAL IMAGERY PROVIDED BY ESRI WORLD IMAGERY MAP (MAXAR), 2019.
- THIS DRAWING IS BASED ON TOPOGRAPHIC SURVEY AND BATHYMETRY PROVIDED BY COMPANY. THIS DATA IS USED AS IS AND HAS NOT BEEN VERIFIED BY MOTT MACDONALD.
- SPILL KITS SHALL BE STAGED AT THE HDD ENTRY AND EXIT LOCATIONS.
- WATER SOURCE: DRILL WATER AND HYDROSTATIC TEST WATER SHALL BE OBTAINED FROM COMPANY APPROVED SOURCE.
- DRILL PATH SHOWN ON THE DRAWINGS REFERS TO THE CENTERLINE OF THE PROPOSED HDD INSTALLATION. DRILLING TOLERANCES MAY RESULT IN SLIGHT DEVIATIONS FROM THESE STATIONS AND ELEVATIONS. PILOT BORE DRILLING TOLERANCES SHALL BE AS FOLLOWS:

ITEM	TOLERANCE
PILOT ENTRY ANGLE	INCREASE ANGLE UP TO 1° (STEEPER), BUT NO DECREASE IN ANGLE ALLOWED.
PILOT ENTRY LOCATION	AS STAKED BY OWNER. NO CHANGES WITHOUT OWNER APPROVAL.
PILOT EXIT ANGLE	DECREASE ANGLE UP TO 2° (FLATTER), BUT NO INCREASES IN EXIT ANGLE ALLOWED.
PILOT EXIT LOCATION	UP TO TEN (10) FEET SHORTER AND 20 FEET LONGER.
PILOT DEPTH	UP TO THREE FEET SHALLOWER ALLOWED. UP TO TEN (10) FEET DEEPER ALLOWED.
PILOT ALIGNMENT	UP TO 5 FEET LEFT OR RIGHT OR THE OWNER SURVEY CENTRELINE BUT NOT WITHIN THREE (3) FEET OF THE RIGHT-OF-WAY/EASEMENT BOUNDARY

E 06/30/21	GD	CAC	ISSUE FOR TENDER
D 03/22/21	GD	CAC	ISSUED FOR PERMIT
C 10/22/20	GD	CAC	UPDATED DRAFT FOR REVIEW
B 09/11/20	GD	CAC	ISSUED FOR 60% REVIEW
A 08/21/20	GD	CAC	ISSUED FOR 30% REVIEW
Drawn by	Accepted	Appr.	Description
08/21/2020	RJR	08/21/20	GD
Scale	Size	Printed Document No.	Approved
1" = 200'	D-SIZE	06566419	08/21/20 CAC
Supplier	Supplier Document No.		

*Chris*  
 06/30/2021



**CONTRACTOR**

**MOTT MACDONALD**

MOTT MACDONALD NY INC.  
 111 Wood Avenue South  
 Isetin, NJ 08830-4112  
 Certificate of Authorization #: 0017019

**South Fork Wind**

Powered by Ørsted & Eversource

ORSTED  
 HDD PLAN & PROFILE  
 VERSION 1  
 SUFFOLK, NEW YORK

DRAWING NUMBER:  
 #SFW01=X01AAE&ELD003





**LEGEND:**

PROPOSED PIPELINE	ACCESS ROAD	BORE PIT	EXISTING WATER LINE
PROPERTY LINE	ACCESS GATE	CABLE LINE	PROPOSED WATER LINE
MINOR CONTOUR	PROPOSED EQUIPMENT	ELECTRIC LINE	NYSDEC DELINEATED TIDAL WETLAND BOUNDARY
ROAD R.O.W.	8 FOOT TALL FENCE/SOUND WALL	OVERHEAD POWERLINE	DELINEATED HABITAT EDGE
EXISTING FENCE	16 FOOT TALL SOUND WALL	TELEPHONE LINE	DELINEATED WETLAND RESOURCE
			PRIVACY FENCE W/ NOISE BARRIER

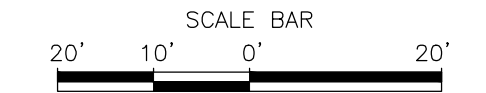

- GENERAL NOTES:**
- TYPICAL LAYOUT OF WORKSPACE SUBJECT TO CHANGE BASED ON HDD CONTRACTOR PREFERENCE.
  - ACCESS GATE TO FIRE HYDRANT SHALL ALLOW FOR PASSAGE OF HOSES HYDRANT.
  - NOISE BARRIER MATERIAL USED AT THE HDD WORKSPACE SHALL HAVE A MINIMUM NRC RATING OF 0.85.
  - ALL VEGETATION IN THE BEACH LANE RIGHT-OF-WAY AND WITHIN THE LIMITS OF DISTURBANCE SHOWN ABOVE WILL BE REMOVED PRIOR TO COMMENCEMENT OF HDD OPERATIONS.

Rev.	Date	By	Appr.	Description
F	07/28/21	GD	CAC	ISSUE FOR TENDER AND PERMIT
E	06/30/21	GD	CAC	ISSUE FOR TENDER
D	03/22/21	GD	CAC	ISSUED FOR PERMIT
C	10/22/20	GD	CAC	UPDATED DRAFT FOR REVIEW
B	09/11/20	GD	CAC	ISSUED FOR 60% REVIEW
Drawn by	07/31/2020	JR	Accepted	
Scale	1" = 20'	D-SIZE	06566419	

*Chris*  
07/28/2021



**CONTRACTOR**

**M M**  
**MOTT MACDONALD**

MOTT MACDONALD NY INC.  
111 Wood Avenue South  
Iselin, NJ 08830-4112  
Certificate of Authorization #: 0017019

**South Fork Wind**

Powered by Ørsted & Eversource

ORSTED WORKSPACE PLAN  
VERSION 1  
SUFFOLK, NEW YORK

DRAWING NUMBER:  
#SF01=X01AAE&ELD004



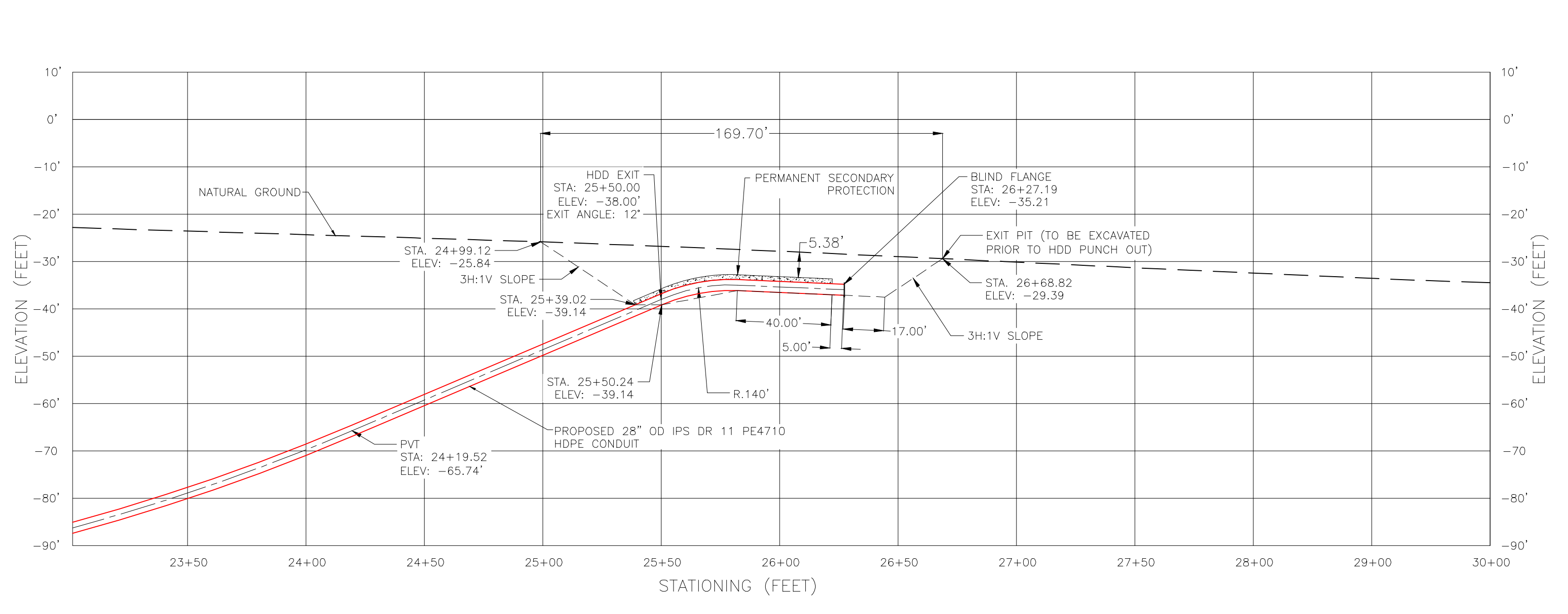
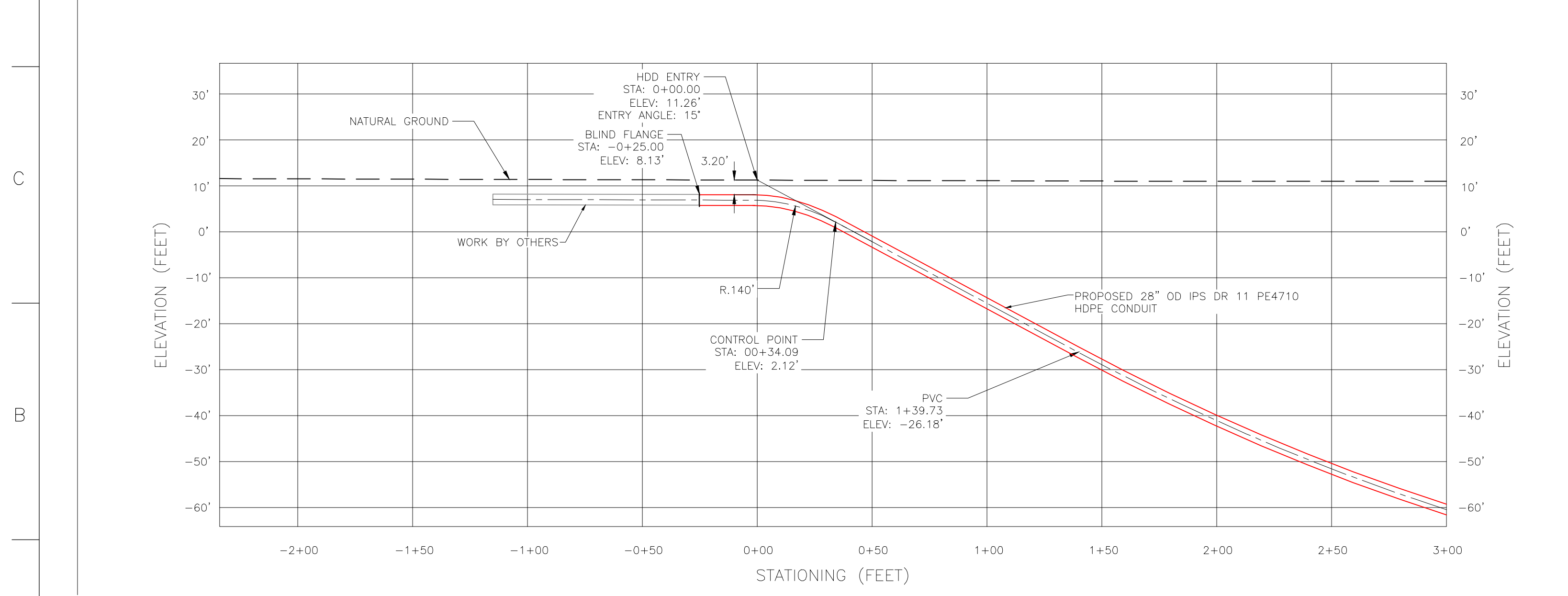
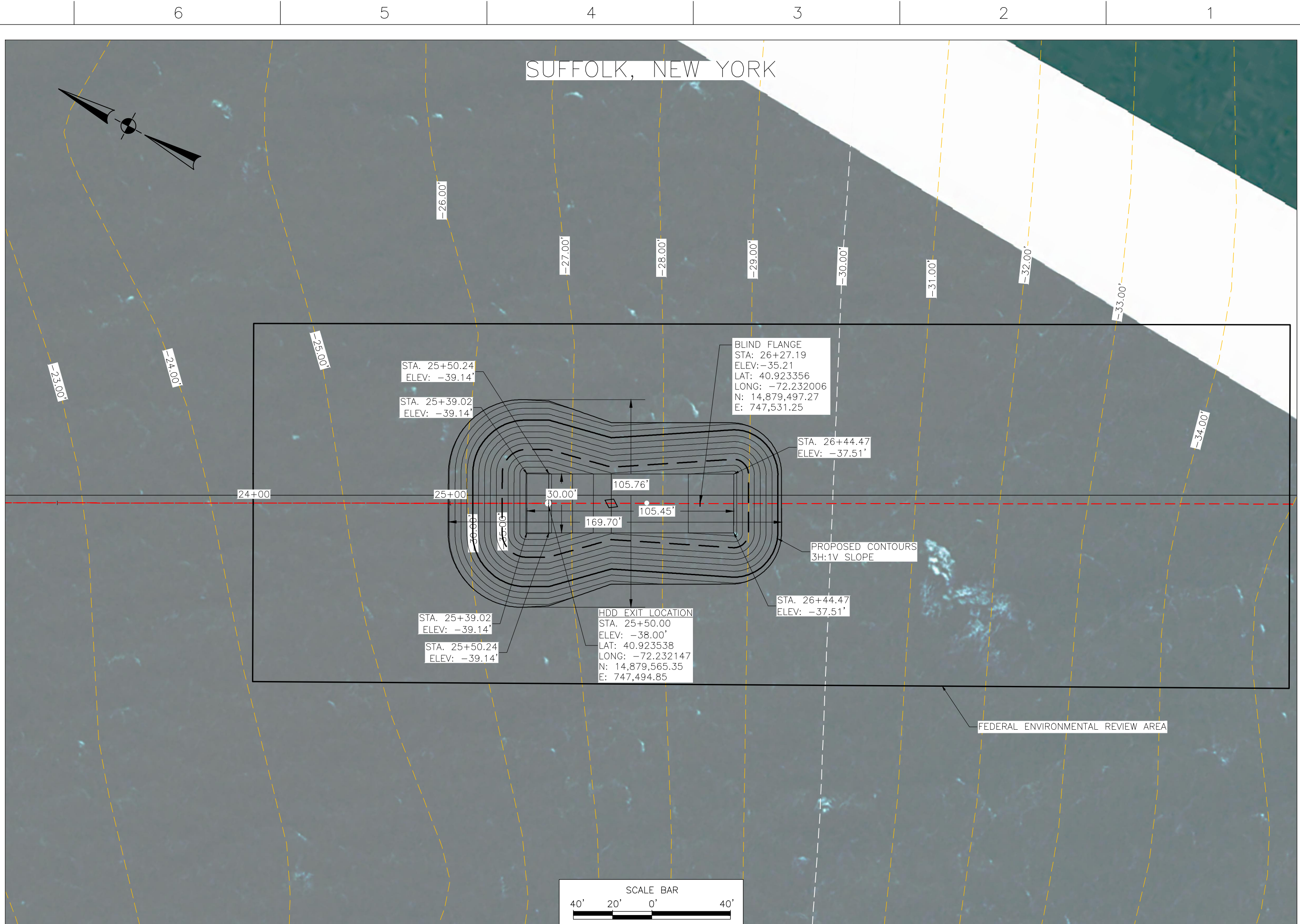

LEGEND:		PROFILE	
		HORIZ. SCALE: 1"=40'	
		VERT. SCALE: 1"=20'	
PROPOSED PIPELINE		ELECTRIC LINE	
PROPERTY LINE		OVERHEAD POWERLINE	
MINOR CONTOUR		TELEPHONE LINE	
ROAD R.O.W.		EXISTING WATER LINE	
EXISTING FENCE		PROPOSED WATER LINE	
CABLE LINE		NYSDEC DELINEATED TIDAL WETLAND BOUNDARY	
		DELINEATED HABITAT EDGE	
		DELINEATED WETLAND RESOURCE	

*Chris*  
06/30/2021

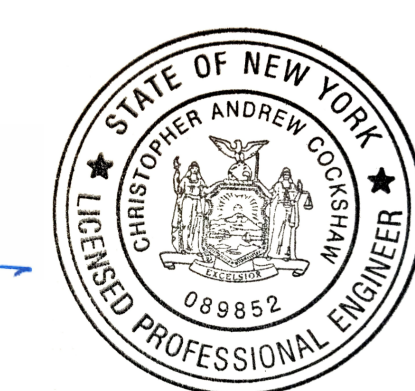

**CONTRACTOR**  
**M M**  
**MOTT MACDONALD**  
 MOTT MACDONALD NY INC.  
 111 Wood Avenue South  
 Iselin, NJ 08830-4112  
 Certificate of Authorization #: 0017019

Rev	Date	By	Appr	Description
E	06/30/21	GD	CAC	ISSUE FOR TENDER
D	03/22/21	GD	CAC	ISSUED FOR PERMIT
C	10/22/20	GD	CAC	UPDATED FOR DRAFT REVIEW
B	09/11/20	GD	CAC	ISSUED FOR 60% REVIEW
A	08/21/20	GD	CAC	ISSUED FOR 30% REVIEW

Drawn by	RJR	Accepted	GD	Approved	GD
Scale	1" = 200'	Size	D-SIZE	Sheet	06566419
Supplier	South Fork Wind		Powered by Ørsted & Eversource		

ORSTED EXCAVATION DETAILS  
 VERSION 1  
 SUFFOLK, NEW YORK  
 DRAWING NUMBER: #SF01=X01AAE&ELD005

NOTES:  
 1) PERMANENT SECONDARY PROTECTION MAY BE PLACED ABOVE THE HDPE CONDUIT AT THE EXIT PIT EXCAVATION, IF CONCRETE MATTRESSES ARE USED FOR SECONDARY PROTECTION, INDIVIDUAL MATTRESSES DIMENSIONS WILL BE APPROXIMATELY 8' WIDE BY 20' LONG BY 1' THICK. IF OTHER SECONDARY PROTECTION METHODS ARE PROPOSED, DIMENSIONS MAY VARY.



# HORIZONTAL DIRECTIONAL DRILL WORK PLAN

August 2021

## **Attachment B DREDGING WORK PLAN**



## **Dredging Work Plan**

Case 18-T-0604

August 2021

Prepared for:

South Fork Wind, LLC

Prepared by:

Ørsted

**South Fork  
Wind**

Powered by  
Ørsted &  
Eversource



# DREDGING WORK PLAN

August 2021

## Table of Contents

<b>ABBREVIATIONS .....</b>	<b>ii</b>
<b>1.0 INTRODUCTION.....</b>	<b>1</b>
<b>2.0 DREDGING WORK PLAN .....</b>	<b>1</b>
2.1 HDD EXIT PIT DREDGE AND BACKFILL FOR PURPOSES OF HDD CONDUIT INSTALLATION.....	1
2.2 CLEARANCE AND BACKFILL OF THE HDD CONDUIT END FOR CABLE PULL-IN. ....	3
2.3 GENERAL.....	5

### LIST OF ATTACHMENTS

Attachment B.1 Clamshell Bucket Drawings and Specifications

# DREDGING WORK PLAN

August 2021

## Abbreviations

Certificate	Certificate of Environmental Compatibility and Public Need
DPS Staff	Department of Public Service Staff
EM&CP	Environmental Management and Construction Plan
ft	feet
HDD	horizontal directional drill
kV	kilovolts
m	meters
NYS	New York State
NYSDEC	New York State Department of Environmental Conservation
SFEC	South Fork Export Cable
SFW	South Fork Wind
USCG	United States Coast Guard

## DREDGING WORK PLAN

August 2021

### 1.0 INTRODUCTION

South Fork Wind, LLC (SFW) will construct, operate, and maintain the South Fork Export Cable (SFEC) in support of the South Fork Wind Farm which will be constructed 35 miles (30 nautical miles, 56 kilometers) east of Montauk Point. The SFEC will be an alternating current electric cable (138 kilovolts [kV]) that will extend from the South Fork Wind Farm in federal offshore waters to coastal New York State (NYS) waters and inland to the existing mainland electric grid located in the Town of East Hampton, New York. This Dredging Work Plan is part of the Environmental Management and Construction Plan (EM&CP) for the SFEC components subject to Article VII of the New York Public Service Law, including the following, hereafter referred to as “the Project”:

- SFEC-NYS: the submarine segment of the export cable buried beneath the seabed from the boundary of NYS waters (3 nautical miles offshore) to a sea-to-shore transition vault located in the Town of East Hampton on Long Island, Suffolk County, New York. The SFEC-NYS includes the sea-to-shore transition via horizontal directional drilling (HDD).
- SFEC-Onshore: the terrestrial underground segment of the export cable from the sea-to-shore transition vault to the SFEC-Interconnection Facility where the SFEC will interconnect with the Long Island Power Authority electric transmission and distribution system in the Town of East Hampton, New York.
- SFEC-Interconnection Facility: a new onshore facility, primarily consisting of a transformer and a 69 kV interconnection cable that will connect to the 69 kV bus in the existing Long Island Power Authority East Hampton Substation in the Town of East Hampton, New York.

The Dredging Works Plan has been developed in accordance with the Certificate of Environmental Compatibility and Public Need (Certificate) to provide details of the proposed works at the HDD exit pit related to (a) HDD Exit pit dredge and backfill for purposes of HDD conduit installation and (b) clearance and backfill of the HDD conduit end for cable pull-in.

### 2.0 DREDGING WORK PLAN

#### 2.1 HDD EXIT PIT DREDGE AND BACKFILL FOR PURPOSES OF HDD CONDUIT INSTALLATION

During dredging of the HDD exit pit within NYS waters, SFW will employ avoidance and minimization measures to minimize impacts to the water column, and to benthic habitats and marine species. In accordance with the Certificate, dredged material will be recovered to a barge and will not be side cast onto the sea floor. SFW will store the dredged material on a barge for later use as backfill for the HDD exit pit with 3 feet (ft) (0.9 meters [m]) of native material, as described below. Alternatively, clean material from an upland source with similar grain size to the dredged material may be used as backfill. If necessary, a local upland source will be identified prior to construction and will be shared with DPS Staff prior to importing fill. SFW will only use barges in good operating condition; not use deck barges, unless

## DREDGING WORK PLAN

August 2021

modified to allow no barge overflow and as approved by the Environmental Monitor and NYS Department of Public Service Staff (DPS Staff) in consultation with the NYS Department of Environmental Conservation (NYSDEC); and use barges or environmental buckets, or dump scows in good working order, sealed and free of leaks, and with doors on the bottom to dump dredged material back within the HDD exit pit, rather than rehandling with a bucket. Backfill works related to the clearance of the HDD conduit end for the cable pull-in are discussed in Section 2.1.

Backfill operations using a dump scow involve positioning the dump scow at the HDD exit pit and opening the scow to release the dredged material to re-settle in the dredged exit pit area. To ensure accurate scow positioning over the exit pit, the as built location data will be used to locate the exit pit area while also accounting for metocean conditions such as current direction, speed and water depth. Due to the fact that the dredged material primarily consists of coarse grain sands, the material is expected to pass through the water column and settle within the exit pit area. During backfill, a turbidity plume that would cause a substantial visible contrast to natural conditions is not expected. Water quality monitoring will be conducted during HDD backfill. Upon final backfill of the HDD exit pit, a post-dredge bathymetric survey will be performed to verify final conditions and ensure no discernible trough.

Additional measures to minimize turbidity include the use of a closed environmental bucket with sealing gaskets or an overlapping sealed design at the jaws and seals, or flaps positioned at locations of vent openings to minimize sediment suspension. SFW will ensure that seals or flaps designed or installed at the jaws and locations of vent openings tightly cover these openings while the bucket is lifted through the water column and into the barge to minimize turbidity. In response to the Certificate Conditions, Figure 1 below and the attached drawings and specifications illustrate a typical clamshell bucket as an example environmental closed bucket which may be used for dredging, or equivalent. Closed environmental buckets will also be equipped with sensors to ensure complete closure of the bucket before lifting through the water column.

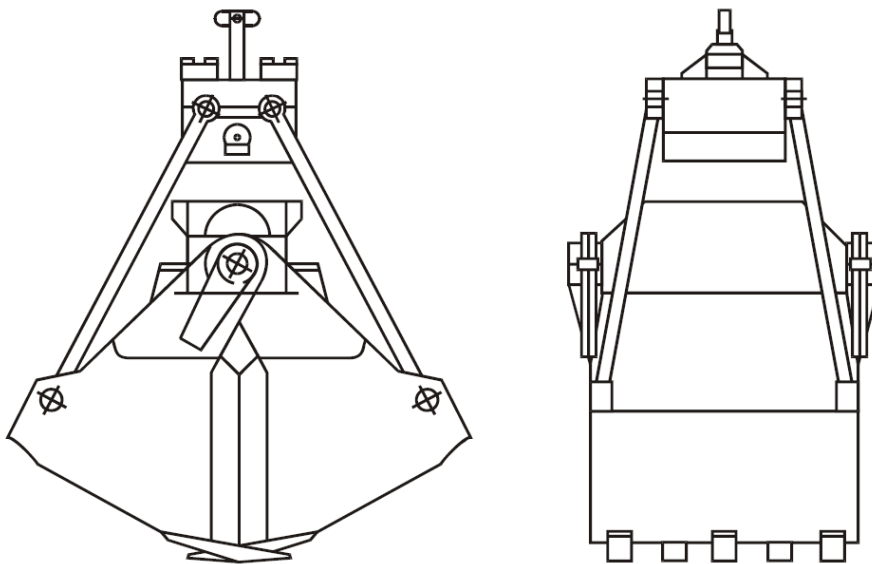

**FIGURE 1 – Typical Clamshell Bucket Design**

## DREDGING WORK PLAN

August 2021

The closed environmental bucket will be operated so as to control the rate of the descent and to maximize the depth of penetration without overfilling the bucket. Bucket retrieval rates will be controlled to minimize turbidity. Additionally, the bucket will be lowered to the level of the barge gunwales prior to release of the load and the excavated material will be deliberately placed in a controlled manner. Operations will be temporarily suspended until any necessary repairs or replacements are made if a significant loss of water and/or visible sediments from the bucket are observed. To ensure the safety of workers, SFW will avoid washing the gunwales of the scow except to the extent necessary and not overflow the barge. SFW will allow a minimum 24 hours of settlement prior to decanting barges. Prior to the first time decanting the barge, SFW will seek approval from DPS Staff in consultation with NYSDEC. SFW will conduct daily water quality monitoring during dredging of the HDD exit pit. Water quality monitoring during dredging activities will follow the procedures described in the Suspended Sediment and Water Quality Monitoring Plan to be included in the Appendix M of the EM&CP and provided separately in response to the Certificate.

Drilling operations associated with HDD will be confined to beginning November 1 and ending on, but inclusive of, April 30 of the succeeding year. Between November 1 and November 15, SFW will be authorized to position and anchor vessels to be used in connection with HDD drilling operations, however the in-water punch-out will not occur prior to November 15. HDD activities are not expected to occur across multiple work windows. The HDD exit pit construction area may be physically marked by lights, at heights and locations to be readily seen and identified by mariners. SFW will consult with the USCG, and the exact configuration and characteristics of the lights will be in accordance with USCG guidance. Additionally, notice will be provided through the USCG Local Notice to Mariners and the SFW Mariners' Advisory website, as further detailed in Section 6, *Community Relations*.

Permanent concrete mattresses or equivalent (e.g., rock bags or gravel bags) will be used to secure the high-density polyethylene conduit to the bottom of the HDD exit pit and may protect the SFEC-NYS cable within the HDD exit pit location covered with three feet of native dredged material or alternative clean material as described above. The exit pit will be backfilled upon completion of HDD operations prior to the installation of the SFEC-NYS, unless construction timing between the HDD work and the SFEC-NYS cable work requires the HDD exit pit to be backfill following cable pull-in.

### **2.2 CLEARANCE AND BACKFILL OF THE HDD CONDUIT END FOR CABLE PULL-IN.**

During the clearance of the HDD conduit end for SFEC-NYS cable installation, a support barge will be positioned (anchored) near the HDD exit. Barge positioning will be done with the assistance of anchor handling tugs. Figure 2 below is a typical graphical representation of the location of barges during the HDD exit pit dredge activities.

# DREDGING WORK PLAN

August 2021

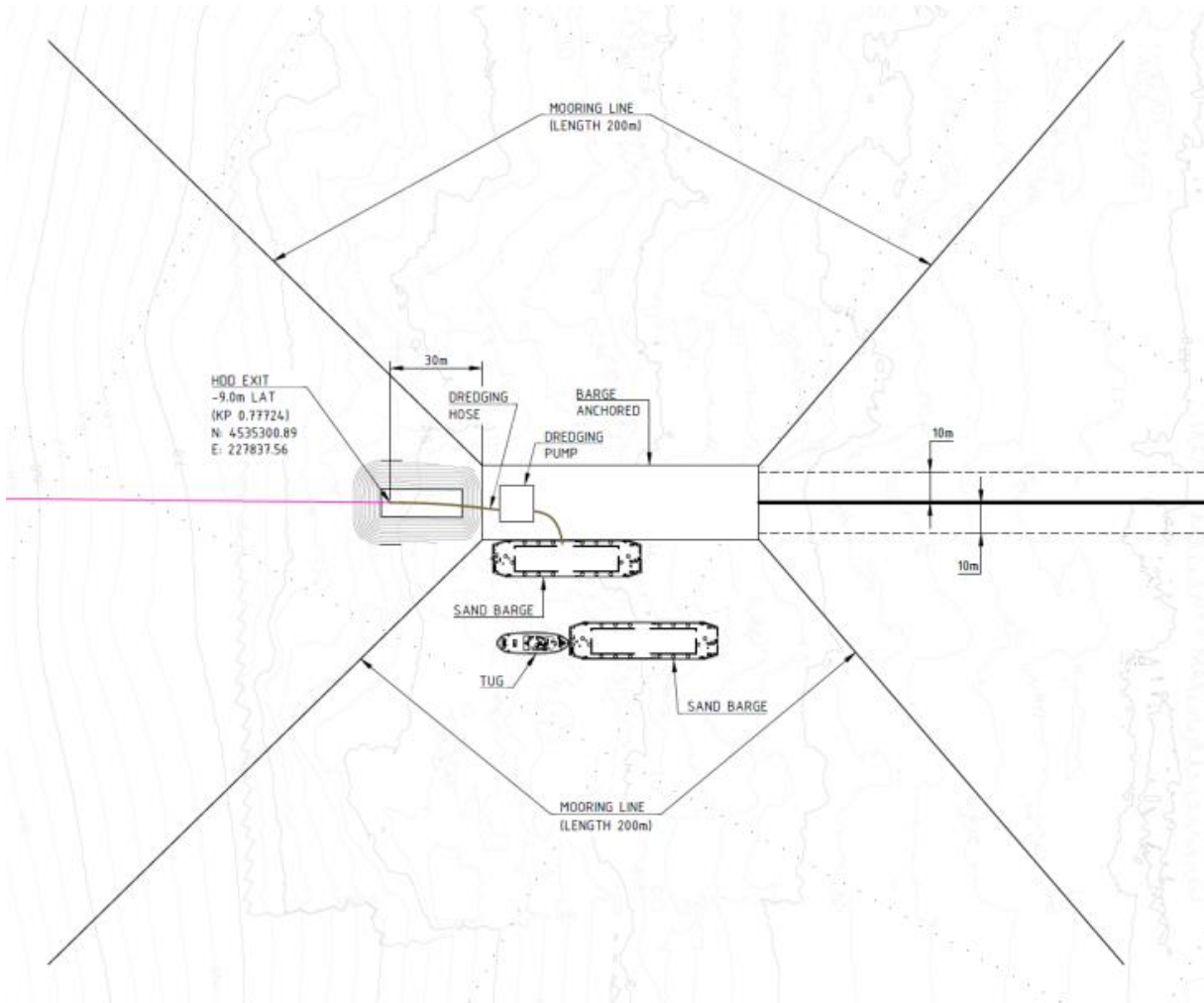

**FIGURE 2 – Typical Representation of Barge Locations During Exit Pit Dredging**

Prior to the cable pull-in the conduit end will need to be exposed through use of a hydraulic dredge pump, or similar (e.g., airlift or controlled flow excavator), operated from an anchored crane barge. This method or similar method of excavation is suitable when working around sensitive infrastructure, such as the existing HDD conduit. The dredge pump will be powered by a hydraulic powerpack on the deck of the barge. Details and specifications of a typical dredge pump are included in Attachment B.1. The dredge pump will be lowered to the seabed and will pump sediment suctioned from the seabed, along the hose connected to the pump, into a barge moored alongside the dredging barge. The barge will store sediment and water generated from the dredge operation.

After a minimum 24-hour settlement period excess water from the dredged sediment will be decanted over the barge sides. Once full, barges will be towed off site by a tug for temporary storage or offloading and disposal. Prior to the first time decanting the barge, SFW will seek approval from DPS Staff in consultation with NYSDEC.

## DREDGING WORK PLAN

August 2021

The dredging works will expose the HDD duct flange and prepare the HDD exit pit area for cable installation. The excavation works will be performed in such a way that the exit pit trench slopes will be dredged so they are suitable and safe working conditions for divers.

The backfilling activities will be carried out by hydraulic means, or similar (e.g. airlift or controlled flow excavator, or those outlined in Section 2.1) of the dredged material back to the pit. A post-dredge bathymetric survey will be performed to verify final conditions.

### 2.3 GENERAL

No in-water seabed disturbing work, will occur between May 1 to June 30 and September 1 to November 15 in any year, except to perform some limited seabed disturbing work activities (i.e. diver clearance and maintenance of HDD exit pit, and backfill of the HDD exit pit) May 1 through May 15 and November 1 through November 15. These HDD exit pit activities that can occur between May 1 through May 15 will be completed in accordance with the Atlantic Sturgeon Monitoring and Impact Minimization Plan to be included in the EM&CP and provided separately in response to the Certificate.

To complete the restoration of the HDD exit pit, the dredged material will be displaced to a barge and if it is not contaminated, and if the backfill of the HDD exit pit occurs prior to May 15 of the first year of construction that HDD work is commenced, the dredged material will be used as the top 3 ft (0.9 m) of backfill for the HDD exit pit. A pre-backfill hydrographic survey will be conducted to calculate the volume and distribution of material required for reinstatement.

SWF does not anticipate the need to dispose of dredged material at an offsite facility. As noted above, dredged material will be stored on a barge for later use as backfill for the HDD exit pit. To verify the suitability of the native dredged material to be backfilled upon completion of activities, SFW conducted sediment testing at three locations in the vicinity of the HDD exit pit on October 23, 2017. Two sediment samples (V-301, and V-302) were collected in the general vicinity of the HDD exit pit. In addition, sample V-300 was collected from within the estimated boundaries of the proposed excavation pit. Survey information and background conditions are provided in Table 1. The laboratory results are included in Table 2 and grain size results are included in Table 3. Laboratory results indicate that sediment in this area is predominately sand and coarse grain sediment with minimal fines. Based on the consistency of the sediment conditions across the three samples, these results are expected to accurately represent the overall sediment conditions in the vicinity of the HDD exit pit as well as describe the sediment that is proposed for dredging. Laboratory results include low level detections for arsenic, copper, and lead, which are well below Class A threshold values<sup>1</sup>. Based on these results, dredged sediment is expected to be suitable for disturbance and eventual backfill in the proposed excavation area upon completion of work. An approved United States Army Corps of Engineers borrow pit is located immediately southeast of the proposed HDD exit pit, further suggesting that sediments in the area are suitable for dredging, removal, and re-use.

---

<sup>1</sup> NYSDEC. 1999. Technical Guidance for Screening Contaminated Sediments. Division of Fish, Wildlife, and Marine Resource.

## DREDGING WORK PLAN

August 2021

**Table 1. Survey Information and Background Conditions for Sediment Samples Near HDD Exit Pit**

Vibracore Location	Sample Date	Sample Time	Estimated Water Depth (m)	#1 Sampled Depth (m)	#2 Sampled Depth (m)
V-300	10/23/2017	7:40am	10.9	2	2.72
V-301	10/23/2017	9:15am	11.3	2	2.75
V-302	10/23/2017	11:15am	18.1	2	3.0



**DREDGING WORK PLAN**

August 2021

**Table 2. Laboratory Results**

Analyte	Method	Results for V-300 (mg/kg)	Results for V-301 (mg/kg)	Results for V-302 (mg/kg)	Method Detection Limit (mg/kg, ppm)	Class A Threshold Value	
						µg/kg	Mg/kg
Benzene	8260C	ND	ND	ND	2.1	590	0.59
Total BTEX	8260C	ND	ND	ND	11	960	0.96
Chlordane (technical)	8081B_LL	ND	ND	ND	0.95	3	0.003
DDD	8081B_LL	ND	ND	ND	0.06	3	0.003
DDE	8081B_LL	ND	ND	ND	0.045		
DDT	8081B_LL	ND	ND	ND	0.085		
Dieldrin	8081B_LL	ND	ND	ND	0.056	110	0.11
Mirex	8081B_LL	ND	ND	ND	0.042	1.4	0.0014
Polychlorinated biphenyls, Total	8082A	ND	ND	ND	0.34	100	0.1
Arsenic	6010C	0.31	0.35	0.51	0.15	14000	14
Cadmium	6010C	ND	ND	ND	0.019	1200	1.2
Copper	6010C	0.99	1.2	1.7	0.088	33000	33
Lead	6010C	0.64	0.64	1	0.13	33000	33
Mercury	7471B	ND	ND	ND	0.004	170	0.17
2, 3, 7, 8-TCDD (sum of toxic equivalency)	1613B	ND	ND	ND	0.0000 45	0.0045	4.5E-06

# DREDGING WORK PLAN

August 2021

Analyte	Method	Results for V-300 (mg/kg)	Results for V-301 (mg/kg)	Results for V-302 (mg/kg)	Method Detection Limit (mg/kg, ppm)	Class A Threshold Value	
						µg/kg	Mg/kg
Key: ND = non-detect (below the method detection limit)							

# DREDGING WORK PLAN

August 2021

**Table 3. Grain Size Information**

<b>Vibracore Sample</b>	<b>Gravel</b>	<b>Sand</b>	<b>Fines</b>
V-300	23.6% (9.9% coarse, 13.7% fine)	75.2% (3.4% coarse, 39.0% medium, 32.8% fine)	1.2% (0.2% silt, 1.0% clay)
V-301	1.5% (0.0% coarse, 1.5% fine)	95.7% (2.1% coarse, 53.4% medium, 40.2% fine)	2.8% (1.7% silt, 1.1% clay)
V-302	1.9% (0.0% coarse, 1.9% fine)	95.5% (0.8% coarse, 29.9% medium, 64.8% fine)	2.6% (1.4% silt, 1.2% clay)