



## TR250 - TR6 Carburettor Overhaul Part II – The Overhaul

By Nelson Riedel, [nriedel@nextek.net](mailto:nriedel@nextek.net)

Revised 12-21-01

We removed, cleaned, and disassembled the carbs in Part I. We also talked a little about carb theory. We talk a little more theory and do the overhaul and reassembly in this part. We reinstall, tune and troubleshoot the carbs in Parts III.

### Float Chamber Overhaul & reassembly

As you look at the parts you quickly realize that all the parts attach to the main body and can be reassembled in about any order. I choose to start with the float chamber because it is nearly always the source of the fuel leaks that got me interested in working on the carbs in the first place.

The floats were pried off the steel clip when the carb was disassembled. The only thing left to remove is the needle valve. This should be unscrewed using the correct size wrench or socket. The valve I removed was 17/32 and I just happened to have a socket. A 14mm wrench or socket is the next closest fit and would probably have worked.

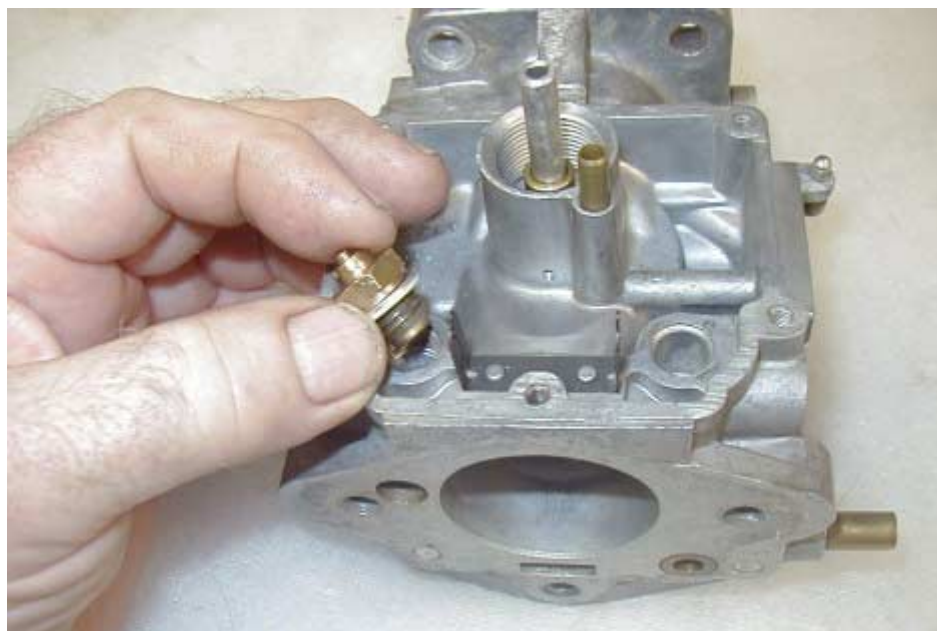

If the valve has been acting up it should be discarded at once lest it end up back in another carb. If the valve is to be reinstalled or kept as an emergency spare, then it should be soaked for an hour or so in the lacquer thinner.

There is a thick aluminum washer under the needle valve. A new value is usually supplied with several different size washers. The correct thickness is 1/16 inch. The valve is installed (or reinstalled) first and then the float hinge pin with floats is inserted into the steel clip as shown below. Note the position of the float. Check that the clip grasps the hinge pin securely. (If not, remove the pin and squeeze the clip together with a small pair of pliers.) Make sure the float moves freely

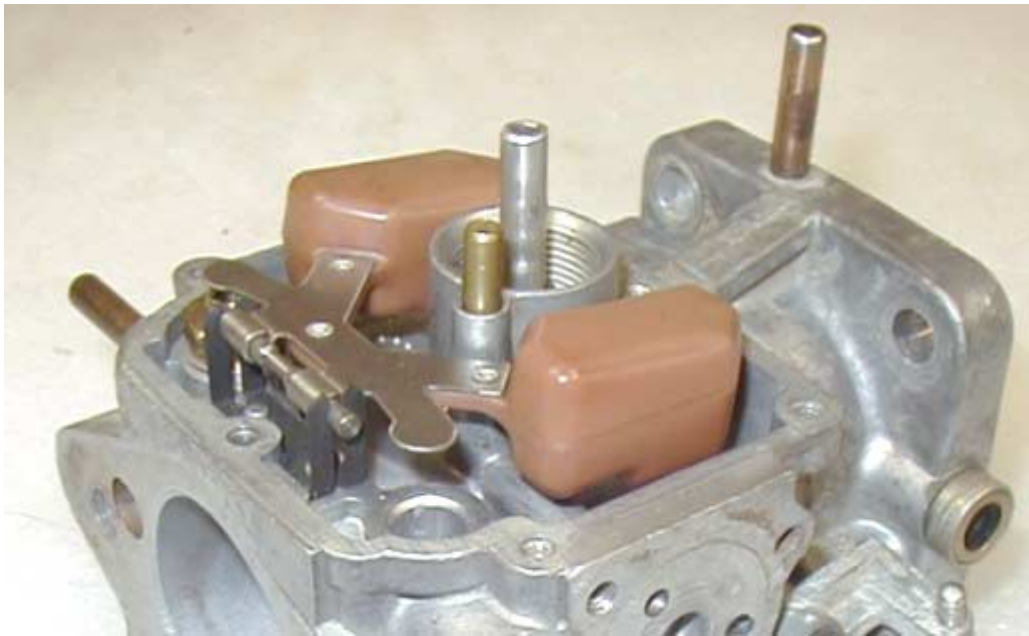

With the carb inverted, make sure the tab on the float is against the valve holding the valve closed and then check that the highest point on each float is 16 to 17 mm above the face of the body as shown in the next photo. (Note: every reference I have has the float setting as 16 to 17 mm but all have different settings in inches. The correct conversion is 0.630 to 0.670 inches. The Haynes manual lists 16 to 17 mm or 0.725 to 0.787 inches. (Is it any wonder the carbs get screwed up?) Bend the tab as required to meet this specification. When done make sure that the tab contacts the valve at a 90 degree angle.

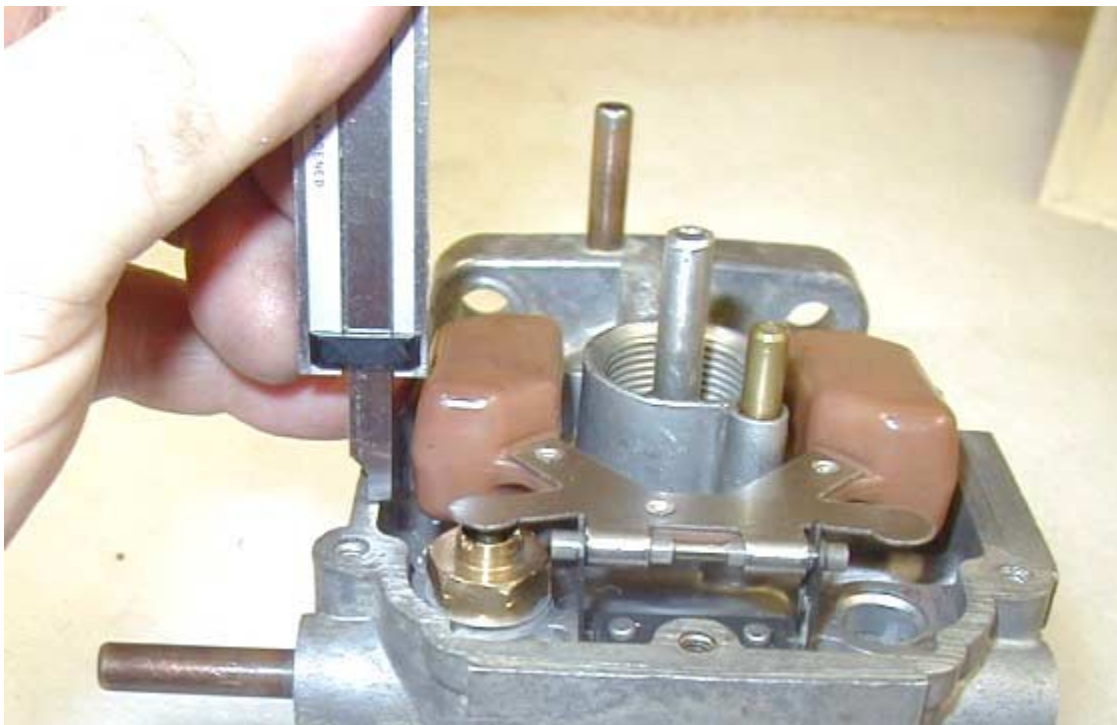

The float chamber is then reinstalled on the body using a new gasket. (Never use an old gasket; it's too much work replacing a leaking one. Also, gasket sealers won't seal gasoline so trying to repair an old gasket with sealer is futile. It's wise to always have a spare gasket on hand.) Make sure the two shorter screws are in the correct holes and then tighten the screws uniformly. Finally, lubricate a new O-ring and slip it on the sealing plug and then inset the plug into the hole in the chamber. This completes the work on the float chamber.

### Replacing Throttle Shaft & Bushes

Inspect the throttle shaft to see if there is wear where the shaft rotates on the bushes in the carb body. If there is wear and the shaft is loose in the bushes then both the shaft and the bushes must be replaced. I understand bushes and shafts are available from TRF and Moss. I understand that the bushes must be reamed after

installation using an expensive (~\$100) reamer. I've not done this job yet as the bushes on the dozen carbs I have all seem to be in good shape. This may be because TRs in Ohio tend to rust through before they wear out. I'll update this should I do a bush replacement in the future.

### Replacing Throttle Shaft (Spindle) Seals

The throttle shaft seals prevent air from leaking into the intake manifold. Small leaks around the throttle shaft are of no consequence when the throttle is at least partially open. However, the leaks can cause a rough idle. It is doubtful that the seals wear out because the typical Triumph gets very little use, especially here in the mid west. However, the seals are subject to deterioration due to age. If the seals have not been changed for 10 or 15 years it's probably a good idea to do so when the carb is off.

The seals are located in the outside ends of the holes that hold the throttle shaft. The seals are removed by inserting an awl or scribe along the edge of the seal and then lifting the seal out as shown in the photo.

The new seals are inserted with fingers, flat side out and positioned as necessary with a blunt screwdriver. The seals are then lubricated and the throttle shaft is then carefully inserted and the spring end is positioned as pointed to by scribe in the photo. The spring should be under tension and the shaft held firmly against the idle adjustment screw.



The shaft is then rotated to the full open position and the throttle disk is inserted into the slot on the shaft. The correct position for the disk is with the two dimples below the shaft and pointing out. The manuals recommend that new screws be used and the ends blunted to prevent them from working loose. I chose to use the old screws together with a small amount of thread lock. After this part is assembled, be sure to check that the throttle shaft rotates freely and the spring holds the throttle closed.



Note the adjustment screw and lock nut to the right of the end of the throttle spring in the adjacent photo. This is the vent lever stop screw. The vent lever is shown in more detail in the next photo. The vent lever is on later carbs, beginning in '73. This venting is discussed at the end of Part I and in the Emissions section next.

The manuals I have show no specification for setting the vent lever adjusting screw. The two new carbs I have that I know nobody has screwed with have the lever adjusted so that it is vertical when the throttle is closed. I used that adjustment as a starting point. Next, I inserted a suitable hose into the vent opening with the brass sleeve on the air filter side of the carb. I then sucked on the other in the hose and noted that as the throttle is moved off idle, the vent is opened. I adjusted the stop screw such the vent is just sealed when the throttle is returned to idle. I then adjusted it a further half turn to make sure it is sealed in the idle position.



This completes the reassemble of the throttle shaft.

### Emission Breathing

The '70 and later TR6 carbs are arranged to dispose of fuel vapors from the fuel tank collected when the engine is idle and crankcase by-pass gasses when the engine is running. In the '73 and later TR6s, vapors from the carb float chamber are also collected when the engine is off and disposed in the same way as vapors from the fuel tank. This later addition is also used together with an added electric valve to eliminate "running-on" or dieseling as us yanks call it.

The breathing apparatus is shown in the next sketch from a Triumph Maintenance Manual. The fuel tank cap seals the tank when closed. The tank is vented through a vapor separator connected to the top of the tank and via hose #5 to the top of absorption canister #4. As the vapor laden air passes through the canister active charcoal granules absorb the vapors and clean air exits through tube #9 at the bottom of the canister. Tubes #2 vent the float carb chambers in the same way on '73 and later carbs.

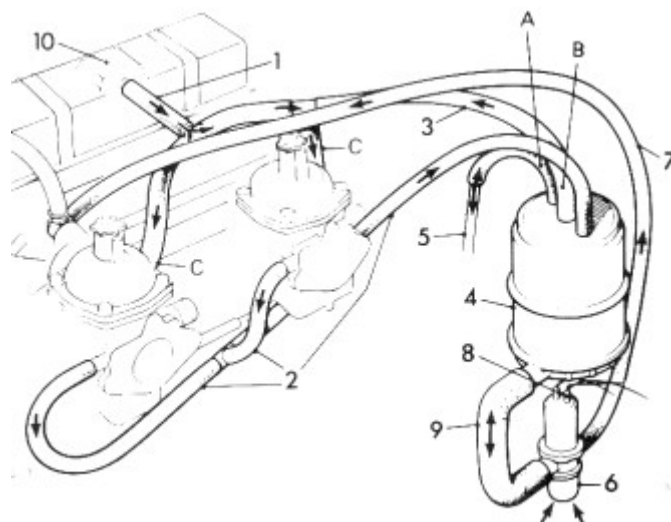

Hoses connect the valve cover (#10) and the canister to ports (C) on the carbs. These hoses are much larger than the ones that connect to the fuel tank and the float chambers. The ports at (C), located above the idle trimming screws, feed directly into the mixing chambers on both carbs.

When the engine is running there is a depression in the carb mixing chamber that draws fresh air into the bottom of the canister through tube #9 and out of the top of the canister port (B) and via tube #3 into the carbs. When the fresh air moves through the canister it purges the carbon granules of the vapors and carries them into the carbs where they are sent into the engine and burned. Bypass gasses from the crankcase rise to the valve cover (#10) where they exit through the port #1 to the same large hoses to the carb ports. The by-pass gasses are also sucked into the carbs and burned in the engine.

Doesn't the big opening in the side of the mixing chamber upset the depression, airflow, etc discussed previously? The change isn't as much as one might expect since the airflow is limited through the canister and the carbs are designed to handle this air. However, cracked or broken hoses can cause leaks that will upset system operation that is most noticeable at idle. As long as all the hoses are in good shape and connected, the system seems to have no effect on performance.

The last part of the breathing apparatus is the electrically operated anti run-on valve introduced on the '73 TR6. Power from the ignition switch in the OFF position is fed through the ON position of the oil pressure switch to the valve, #6 in the sketch; the valve operates when the ignition is turned off and there is still oil pressure. The operated valve closes the external air input to the bottom of the canister via tube #6 and instead connects tube #6 to the intake manifold via tube #7. The depression in the intake manifold sucks air out of the canister and via tube #2 to the float chamber creating a depression in the float chamber. This depression in the float chamber prevents fuel entering the carb via the jet thus preventing run-on or dieseling. The valve releases a few seconds after the ignition is turned off when the oil pressure drops.

### Temperature Compensator, Idle Trimming Screw & Bypass valve Overhaul.

These components are on the side of the carb body that faces the front of the car as shown in the diagram below. There is an air channel from the air cleaner to the throttle plate side of the air valve used by both the temperature compensator and the idle trimming screw. The temperature compensator consists of a temperature sensitive bi-metallic blade that moves a plug attached to the end in and out of an orifice from the air channel to the main chamber. The plug controls the flow of air that goes around the air valve. Adding air from this channel leans the fuel mixture. When it is very cold the plug is in all the way in cutting off the extra air path thus giving a richer

mixture. When the engine and surrounding air is hot, the plug is all the way out giving maximum additional air and a leaner mixture.

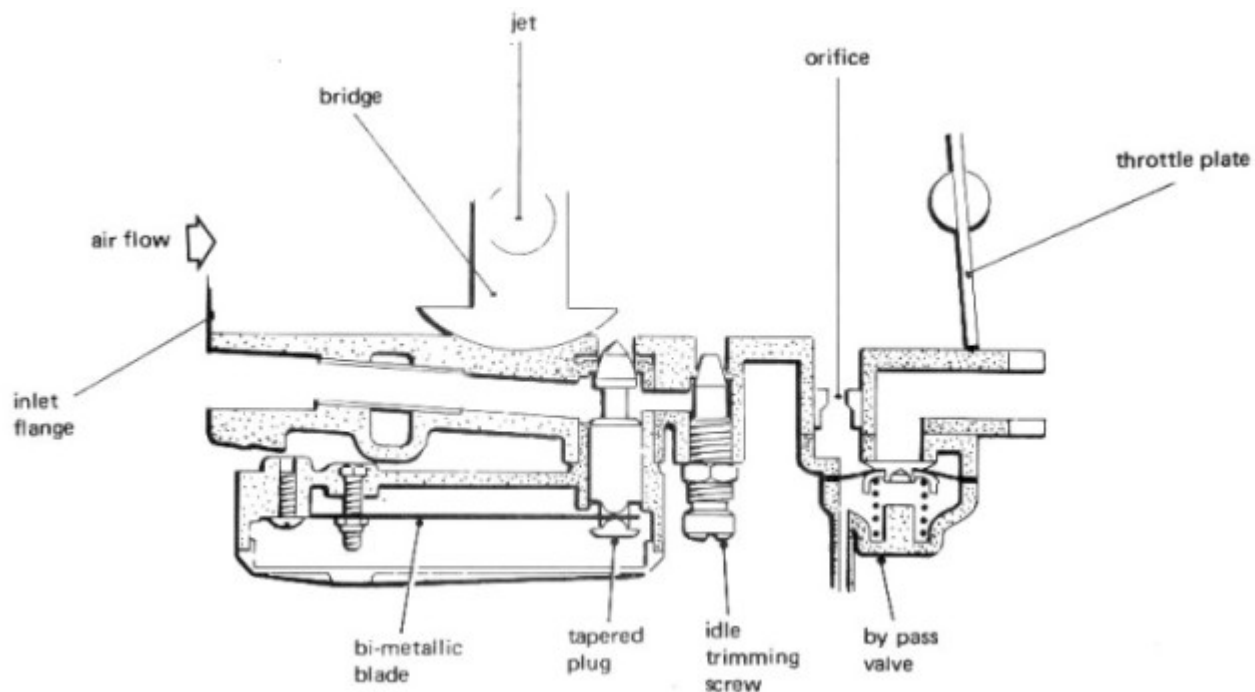

**Temperature Compensator:** The photo shows the temperature compensator with the plastic cover removed. The bimetal strip runs the length with the plug on the right end. The first maintenance concern is to make sure the plug moves freely and that it responds to temperature changes. The one shown in picture had a stuck plug. It freed up after soaking in thinner for a half hour or so. Cold faucet water was run over the bi-metal strip and the plug moved to the fully closed position, as it should. Next, near boiling water was run over the bi-metal strip and the plug went to the fully open position, again as it should.

Steve Sutton has researched this issue and found considerable variations among temperature compensators. He even found new ones set as much as 20 degrees apart. His research has shown best operation with the valve just starting to open at 115° F and fully open at 140° F. His view (which I concur) is that matching the compensators in a multiple carb system is probably more important than the actual temperature at which they open. He put together a neat note with additional information on the compensators at:

<http://www.vtr.org/maintain/temp-compensators.html>

After reading Steve's note, I decided to tune up my compensators. The middle photo on right shows a completely disassembled unit. First, the bimetal strip was straightened using pliers. The unit was then reassembled making sure to not over tighten the adjustment nut.

A tea kettle of boiling water and a pitcher of warm water were taken to the workshop. The two temperature water were mixed the water to get a 115° F solution. The nut was then adjusted so that the compensator just started to open when placed in the water. Hot water was then added to bring the temperature up to 140° F and tested again. It was found that the nut could be tightened a little and still



be fill open at 140° F. Cooler water was then added to bring the temperature back down to 115° F and double checked. The next time I do this I'll swipe a second freezer container from the wife and set one up at 115° F and the second at 140° F. That will allow me to go back and forth and do the adjustment in a couple minutes. I'll probably use more water so that the temperature will remain fairly constant over the few minutes required.

The thermometer pictured cost about \$5 in the house wares area of the local supermarket. It has a 0° F to 225° F scale. The calibration was checked with ice water and boiling water and found it to be accurate. I use it to check radiator coolant and oil temperatures also. The wife has similar thermometers she uses for cooking. It would probably be OK to use the cooking thermometers if cleaned afterwards but I didn't out of fear she might catch me.



The compensator is reinstalled on the carb body after placing the smaller washer in the hole in the body and the larger washer fitted on the spout containing the plug.

**Idle Trim Screw:** The idle trim screw uses the same chamber as the temperature compensator to provide a minor idle mixture adjustment. The richest setting is with the screw all the way in blocking any additional air. The screw is cleaned and then reinstalled and initially set to the fully closed position.

**Bypass Valve:** The bypass valve provides a channel for air to flow around the throttle disk. A very high depression can exist in the intake manifold if the engine is operating at a high RPM with the throttle closed such as might occur when decelerating. Poor fuel combustion occurs in this situation giving increased exhaust emissions. This is frequently evidence by exhaust popping during deceleration. The bypass valve senses the high depression and allows some air to go around the throttle plate to reduce the depression to the desired level. The sketch on the right shows a cross section of the bypass valve. Normally the valve is held against the seat by the spring. The pressure on the carb side of the diaphragm is the same as in the mixing chamber and the pressure on the other side is kept at manifold pressure by the sense port. If the manifold pressure drops and becomes a depression, then the pressure on the carb side of the diaphragm will push the diaphragm and valve away from the seat opening a passage from the mixing chamber to manifold bypassing the throttle plate.

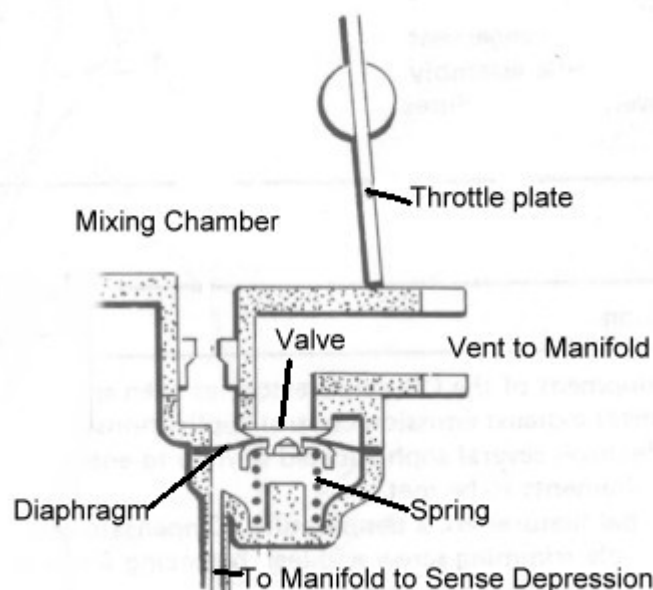

Two variations in bypass valves were used on the TR250/TR6s. The early valves on the TR250 and '69 TR6 used external hoses and pipes to sense a manifold depression. The left photo below shows that type of valve on my TR250. After '69 the valves have an internal passage to sense a manifold depression. The right photo shows that type of valve on a '76 TR6 carb. A second variation is whether the valve is adjustable. The valve on the right can be adjusted by turning the screw on the outside end of the valve. The nut on the other end of the adjustment screw pushes against the spring. Turning the screw clockwise pulls the nut away from the valve reducing the spring compression hence allowing the valve to operate at a lower manifold depression (operate easier). The valve on the left has a blunt end rather than the adjustment screw. I think this type of valve can be adjusted from inside the valve. However, it is my opinion that valves with no external adjustment screw will likely not need readjustment since it is unlikely anyone has been able to screw up the adjustment.



The bypass valve is attached to the carb body by three slotted head screws as shown in photos above. The valve is constructed of two sections held together by three Phillips head screws as shown in the left photo below. The three screws are removed, the parts separated, and the diaphragm removed. All parts, shown in the right photo, are then cleaned thoroughly with lacquer thinner. Special attention should be given the area where the brass valve seats against the inner casting to make sure it seals properly. The diaphragm in the left photo was old and brittle. A replacement diaphragm that comes with two mating gaskets is shown in the right photo. The spring in the right photo looks a little mangled. A better spring from a junk carb was used when reassembling the unit.



The left photo below shows the area of a late carb main body where the bypass valve attaches. Note that a gasket that goes between the body and valve is in position. The gasket has a small hole near the top for the manifold sensing function. The carb rebuild kits comes with two types of gasket, one with the little hole as shown and another type without the hole for the early carbs that sense via external tubes and pipes. Note there is a gap in the gasket between the large holes. This allows a small amount of air to bypass the throttle plate even when the bypass valve is closed. One might ask, why did they do that? I don't know but one possibility is that if the gasket completely seals the two sides, then it might be prone to fail in that spot. If the gasket failed, the idle speed would increase significantly. So, maybe they just cut out that part -- essentially making the failure standard production. (That is probably a poor choice of words.)

The right photo shows the side of a late bypass valve that mates with the carb body. The sensing passage is indicated at the top. When the valve is closed, the brass plug is firmly against the back of the round hole in the center sealing the passage. When a large depression is sensed via the sensing passage, the the brass plug lifts away from the round hole allowing flow from the the triangular hole to the round hole. The earlier valve is identical except instead of the sensing hole there is a small tube at the top of the valve.



Before the final assembly of the adjustable bypass valve, the adjustment screw, spring washer and adjustment nut are assembled into the larger casting. The initial adjustment should position the nut about one screw turn after it enters the hex section of the casting. This is the minimum sensitivity position and keep should keep the valve firmly closed during initial carb tuning.

The left photo below shows the placement of a gasket and the the diaphragm on the smaller casting. A gasket has been placed on the diaphragm and the spring positioned in the right photo. The larger casting is then placed over the smaller casting and secured with the three small Phillips head screws. The valve is then attached to the main body using the three slotted head screws and a gasket between the valve and body.



### Cold Start Valve (Choke) Overhaul

The components discussed above (temperature compensator, idle trim screw and bypass valve) are positioned on the forward side of the carb and alter the carb behavior by changing the air flowing through side passages. This section deals with the cold start valve (choke) that is positioned on the rear side of the carb and alters the carb behavior by changing the fuel flowing through special passages. The job of the cold start valve is to provide a much richer than normal fuel air mixture when starting and operating a cold engine.

The backside of the carb body with the cold start valve removed is shown on the left. The scribe is pointing to a passage to the float chamber. Across from this hole is a recessed slot with a hole that leads to an outlet in the mixing chamber. Air passing this outlet creates a depression over the end on the outlet like the depression created over the main jet. In normal operation with the cold start valve off, both the hole and the slot are





covered and no fuel flows through these passages. When the cold start valve is turned on, a passage is provided between the hole and the slot and fuel is sucked out of the float chamber and into the mixing chamber of the carb.



The thick disk provides the fuel control. There is a passage inside the disk from the slot to the four small holes. The disk is held against the carb body by a spring. For valve off, the disk is positioned such that both the hole and slot on the carb body are covered. Rotating the disk turns on the valve. In the minimum on position, the slot on the disk is over the hole in the body and one of the little holes in the disk is over the slot in the body allowing fuel to flow through one small hole. As the valve is turned on further (rotated) the slot on the disk will still be over the hole on the carb body and two of the small holes on the disk will be over the slot in the carb body allowing more fuel to flow since it may flow through the two small holes. As the valve is rotated further fuel can flow through three and then in the full on position, four of the small holes.

The cold start valve is disassembled by removing the nut. The pieces are shown in the next photo. The overhaul consists of inspecting all the components and cleaning all passages. It is possible to assemble the valve with the disk rotated 180 degrees. The disk is positioned correctly if, when rotated to the off position, both the holes and the slot in the disk are nearer the bottom. (That other carb that hadn't been disassembled came in handy here.) The valve is reinstalled using a new gasket between the valve and carb body.



### Modifying Late Cold Start Valves

The TR250 and TR6s through '73 use a flexible choke cable. These cold start valves have springs that return the valve to the off position when the cable is slackened by pushing the choke knob in.

The later cold start valves don't have a spring. In fact, there is a spring-loaded ball that rubs against the cam on the valve that tends to restrict movement. There is a detent in the cam that the ball fits that tends to lock the choke in the partial on position. The choke cable is a stiff wire that is supposed to pull the valve open and push it closed.

I've had a lot of trouble with the stiff cable. The problem is that when pushing the choke knob in, one or both of the outer covers are forced out of the fixture at the knob end of the cable. Both '76 TR6s I bought had cables that failed in this way. I bought a new cable for the one that was restored. It lasted less than a year. Bought another one and it only lasted about 6 months.

At \$50 a throw, I decided to repair the two broken cables. First tried squeezing the crimp fitting of the fixture on the outer cover. Lasted a few days. Epoxy next, lasted a few weeks. Finally designed a clamp to really squeeze the fixture on the cover. Worked for a few days then one day when the knob was pushed in, the stiff wire from one carb bent, folded and broke where it connects at the knob end. Rats! Must have squeezed the outer cover so hard that it squeezed down on the inner cable. Moved the clamp to the other broken cable but didn't tighten it so much. Outer cover came out. Made it tighter, a wire broke the next day. What a pile of crap! The area that fails is shown in the following photo. This cable has been repaired with epoxy. The masking tape was to hold the two cables in position while the glue dried. Another advantage of the early cable is that it can be locked in position by rotating the knob 1/4 turn clockwise.



I think this was about the time I bought that new set of carbs that were on the '76 TR6. These carbs have spring loaded cold start valves. I bought the earlier design cable with the flexible inner cable. That was in '84 or '85. It is still working. Moral of the story --- don't try to push a wire.

The later valves can be modified to work with a spring. The valve is disassembled, the frame placed in a vise and the cylinder housing the spring loaded ball is driven out with a punch as shown in the photo below. Springs are purchased (from Moss) and installed as showed in the right photo below. Note that the steel ball is gone. With the spring installed, either the older or the newer design cable can be used. Even a cable that has failed by the outer cable coming loose at the knob end will probably still work with the spring loaded valve. (The cable shown earlier had been repaired with epoxy and used several years on a '73 that had spring loaded cold start valves.)



### Overhauling the Top of Carburettor

The parts accessed via the top of the carb include the damper assembly, the air valve, air valve return spring, the diaphragm and the metering needle and associated parts attached to the bottom of the air valve. The four screws securing the washer and diaphragm ring to the top of the air valve should be removed, the diaphragm lifted off and then all the parts thoroughly cleaned and inspected.



The following sketch taken from the Haynes manual shows a cross section of the components associated with the adjustable metering needle on the '70 and later carbs. A long Allen wrench (taken from the mixture adjusting tool discussed later) is used to turn the needle adjusting screw. Turning the screw clockwise raises the needle making for a richer mixture. The opposite direction yields a leaner mixture. The needle adjusting screw has an O-ring seal that prevents the oil from draining from the air valve guide rod. Remember that note about the carb leaking oil that fell out of the carb when the top was removed? Well, it's that O-ring that is at fault. The only reason to remove the needle is to replace this O-ring or a broken needle. (How does one break a needle????? I've seen several --- maybe someone was so upset with the carb that they ran a blunt object like a hammer through the main chamber.)

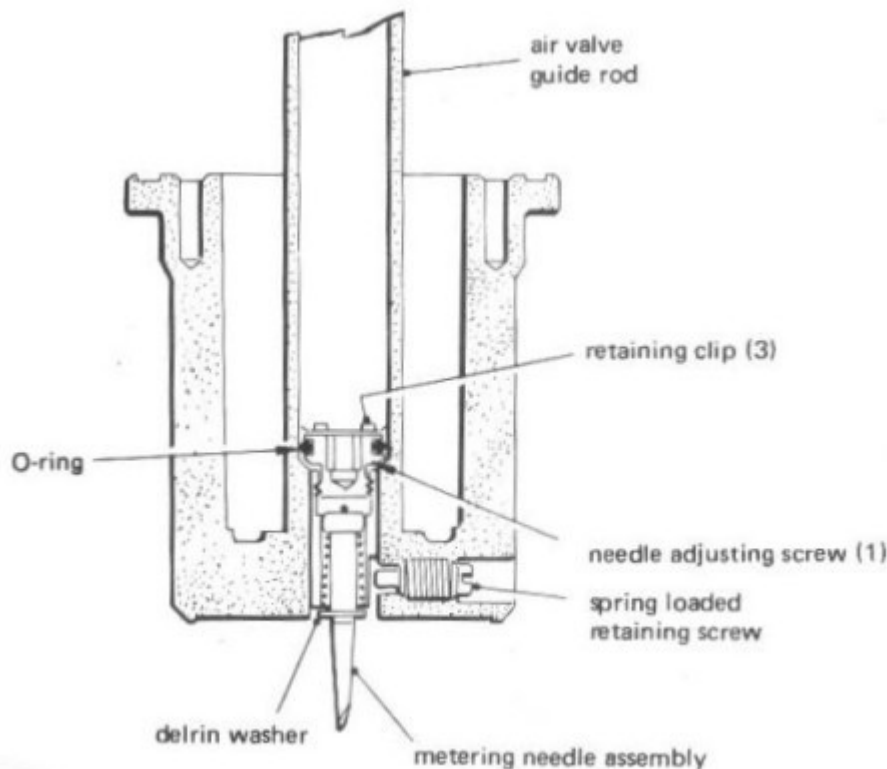

The needle is held in a carrier by a spring and is free to move side to side. This allows the needle to adjust position as required when the air valve moves within the design clearances. The needle and carrier are removed together and no attempt is made to separate the needle from the carrier. To remove the carrier, carefully turn the adjusting screw counterclockwise. The retaining screw is left in so that the needle carrier doesn't turn with the adjusting screw. If the adjusting screw becomes hard to turn, remove the retaining screw. The needle carrier should be extended far enough at this point so that it can be stopped from turning with your fingers.

The needle and carrier can be pulled free once the retaining screw is removed and the adjusting screw is completely unscrewed from the carrier. To get at the O-ring, a steel rod is inserted in the bottom side of the air valve guide rod and gently tapped with a small hammer driving the adjusting screw and the retaining clip out the top

of the air guide rod. These parts are shown in the next photo. Left to right at the bottom are the retaining screw, the adjusting screw, the retaining clip and an old O-ring.

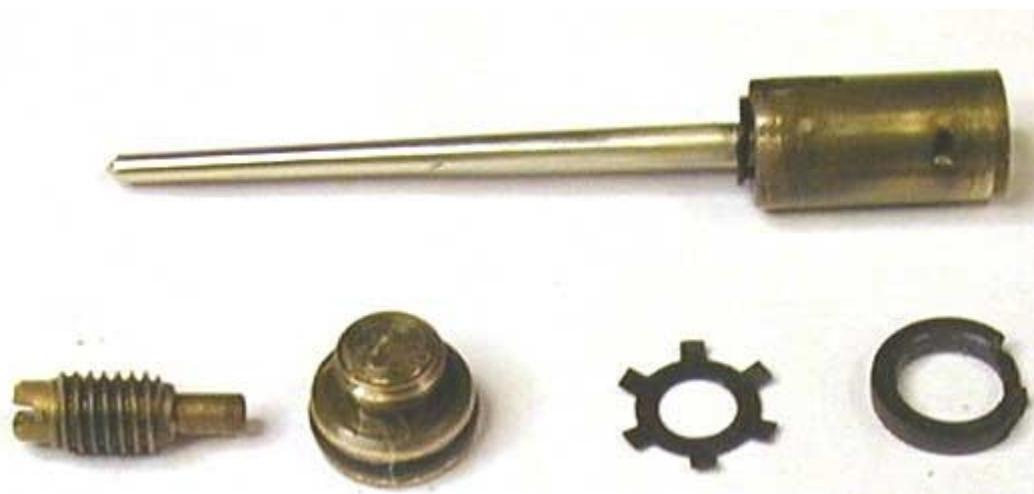

The new O-ring is lightly lubricated before it is installed on the adjusting screw. The adjusting screw can then be inserted in the top of the air valve guide followed by the retaining clip and tapped into place with the steel rod and hammer. Be sure that the retaining clip is firmly against the needle adjusting screw. The needle valve and carrier can be reinserted and the adjusting screw tightened to lift the needle into position. The retaining screw is installed next; making sure the spigot end of the screw enters the slot in the side of the needle carrier.

Next, test the the needle adjusting screw. Turn it as far as it will go clockwise. This pulls the needle up into the air valve to the highest position corresponding to the richest mixture. Now turn the needle counterclockwise and the needle should move lower. Count the turns of the screw. You should find that after about three and one half turns, the needle stops dropping --- the screw is out of the carrier. The screw must be engaged in the carrier when in use to prevent the needle from dropping further. About three turns is the maximum the needle should be set off from full tight. This corresponds to the leanest setting. If, after the air valve is installed, the screw is turned too far so that the screw is out of the carrier, it may be necessary reach into the air input with your finger and push the needle carrier into the air valve to get the screw started again.

The correct starting adjustment for the needle is one turn counterclockwise from the upper most (screw tight) position.

Next, the diaphragm is installed on the air valve. There is a slot on the top of the air valve that mates with a tab on the diaphragm. It is difficult to position the diaphragm correctly and then hold it in position while installing the sealing ring, washer and four screws. It's easier to install all the parts with the screws loose, then position the diaphragm tab in the slot and tighten the screws.

The air valve is lubricated with light oil (SAE 20) and then carefully inserted in the carb body, making sure that the needle slides into the jet. There is a tab on the diaphragm that mates with a slot in the carb body. If every thing is positioned correctly, the two vent holes in the bottom of the air guide are on the manifold side of the carb body. The air valve return spring is then inserted over the air guide rod and the cover attached. The cast boss on the side of the upper part on the cover is positioned to the air filter side of the carb. The four screws secure the cover making sure that the identification tag is secured under one of the screws. A new gasket is inserted over the threaded part of the damper assembly knob and the damper assembly is screwed into the top.

We install and tune the carbs in Part III

**TR250-TR6 Carbs:**    [Part I - Disassembly & Theory](#)  
                               [Part II – The Overhaul](#)  
                               [Part III – Reinstall, Tune and Troubleshooting](#)  
                               [Powder Coating ZS Carbs](#)  
                               [Replacing Fixed Needles with Adjustable Needles](#)  
                               [Air/Fuel Monitor](#)  
                               [Using Air/Fuel Monitor](#)

***Buckeye TRIUMPHS Technical Page***

*hosting donated by*



© 2001 Nelson A Riedel