

Triumph

Service Training Notes

1973

Emission Control Systems

Spitfire 1500

GT6 Mk. III-TR6

Stag

To be used with filmstrip
No. 1009

Issued by
Rover Triumph
Sales and Service Training Centre
British Leyland UK Limited
Coventry, England

Copyright in this publication belongs to the British Motor Industry Heritage Trust,
and no part of it can be reproduced without their permission.

Address all correspondence to the:

British Motor Industry Heritage Trust
Archive Department
Heritage Motor Centre
Banbury Road
Gaydon
Warwick CV35 0BJ
England

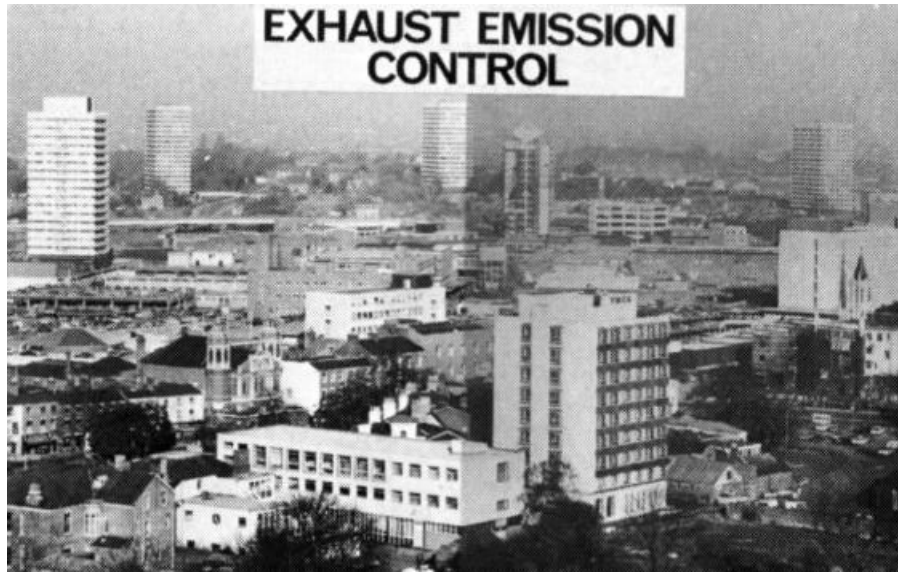

Introduction

This booklet and its accompanying filmstrip show the essential features of an engine's exhaust emission system to conform with the U.S.A. Government requirements.

Main Sections

- [Part 1](#) Car Specifications for 1973 Spitfire 1500, GT6 Mk. III, TR6 and Stag
- [Part 2](#) Crankcase Emission Control systems on Single- and Twin-Carburettor Systems
- [Part 3](#) Evaporation Loss Control Systems
- [Part 4](#) Stromberg Carburettor- Principles of Operation
- [Part 5](#) Stromberg Carburettor- Servicing
- [Part 6](#) Triumph Stag, Air Intake- Operation and Servicing
- [Part 7](#) Exhaust Emission System- Fault Diagnosis

Changes to the Federal Government Regulations are made at regular intervals. To ensure satisfactory servicing always check for latest bulletin information which has been issued since the publication of this book.



FRAME 1

Introduction

During the last few years air pollution has become 'headline' news in nearly every country in the world.

This has led to new and ever-increasing legislation on the petrol engine to prevent unburnt fuel (hydrocarbons), carbon monoxide and oxides of nitrogen from reaching dangerous levels and so become damaging to health.

In certain areas of the world a number of geographic circumstances have aggravated the situation to such an extent that when the sun acts upon the exhaust gases a photo-chemical change takes place and 'smog' is produced.

To combat the exhaust emission problem all cars exported by Triumph are fitted with special equipment to comply with the laws of the country to which they are dispatched.



FRAME 2

Part 2

Emission Control Engine Details-

Spitfire 1500

1. Exhaust valves stellite faced to maintain effective valve seating between servicing intervals.
2. Cylinder head compression 7.5 : 1

3.

Camshaft	Opens	Closes
Inlet valve	18 deg. B.T.D.C.	58 deg. A.B.D.C.
Exhaust valve	58 deg. B.B.D.C.	18 deg. A.T.D.C.

4. Distributor has centrifugal advance and vacuum retard.
5. Carburetter: Single Stromberg 150 CDSE (V). Top adjustment.

Details:

- (a) Biased type spring-loaded needle (towards air cleaner).
 - (b) Mixture needle adjustment through top of carburetter (for approved personnel only-not available to owners).
 - (c) Temperature compensator for mixture.
 - (d) Deceleration by-pass valve mounted on carburetter.
 - (e) Trim screw for very fine mixture adjustment.
 - (f) Float-chamber vent valve.
6. Spark plugs, Champion N12Y.

Emission Control System- Ignition and Carburetter Settings-

Spitfire 1500

Idle speed (rev/min)	800 to 850
Ignition timing, static	10 deg. B.T.D.C.
Ignition timing at idle	2 deg. A.T.D.C.
Distributor part number (AC Delco)	7992198
Dwell angle	38 to 40 deg.
Basic carburetter settings	Fixed
Idle CO level, engine warm	0.5 to 2.5%
Equivalent air/fuel ratio at idle (approx.)	14.4 : 1 to 13.6 : 1

Spitfire 1500 Distributor Stanpart Number 313232

Centrifugal advance (check at decelerating speeds)

Distributor Speed rev/min	Degrees of Distributor Advance	
	Minimum	Maximum
Below 400	No advance to occur	
500	0	2
700	2	6
775	4	6.5
1,100	5	7.25
1,750	7	9
2,400	9	11

Vacuum Retard

No retard before 2 1/2 inHg. Fully retarded, 6 +/- 1 deg. at 15 inHg.

Caution: U.S. Federal Standards
Control of Air Pollution

Unauthorized interference with, or adjustment to, distributor or carburetter settings will almost certainly result in vehicles failing to meet the legal requirements in respect of air pollution.

Adjustments to these setting must be made by authorized personnel **only**.



FRAME 3

Emission Control Engine Details-

GT6 Mk. III

1. Exhaust valves stellite faced to maintain effective valve seating between servicing intervals.
2. Cylinder head compression 8.0 : 1
3.

Camshaft	Opens	Closes
Inlet valve	18 deg. B.T.D.C.	58 deg. A.B.D.C.
Exhaust valve	58 deg. B.B.D.C.	18 deg. A.T.D.C.
4. Distributor has centrifugal advance and vacuum retard.
5. Carburetter: Twin Stromberg 150 CDSE (V). Top adjustment.

Details:

- (a) Biased type spring-loaded needle (towards air cleaner).
- (b) Mixture needle adjustment through top of carburetter (for approved personnel only-not available to owners).
- (c) Temperature compensator for mixture.
- (d) Deceleration by-pass valve mounted on carburetter.
- (e) Trim screw for very fine mixture adjustment.
- (f) Float-chamber vent valve.
6. Spark plugs, Champion N12Y.

Emission Control System- Ignition and Carburetter Settings-

GT6 Mk. III

Idle speed (rev/min)	800 to 850
Ignition timing, static	12 deg. B.T.D.C.
Ignition timing at idle	4 deg. A.T.D.C.
Distributor part number (AC Delco)	EID 113907
Dwell angle	40 to 42 deg.
Basic carburetter settings	Fixed
Idle CO level, engine warm	0.5 to 2.5%
Equivalent air/fuel ratio at idle (approx.)	14.4 : 1 to 13.6 : 1

GT6 Mk. III Distributor Stanpart Number 312232

Centrifugal advance (check at decelerating speeds)

Distributor Speed rev/min	Degrees of Distributor Advance	
	Minimum	Maximum
Below 400	No advance to occur	
500	0	1
700	1	3
1,100	4	6
1,500	8.5	10.5
2,000	8.5	10.5

Vacuum Retard

No retard before 2 1/2 inHg. Fully retarded, 8+/- 1 deg. at 15 inHg.

Caution: U.S. Federal Standards
Control of Air Pollution

Unauthorized interference with, or adjustment to, distributor or carburetter settings will almost certainly result in vehicles failing to meet the legal requirements in respect of air pollution.

Adjustments to these setting must be made by authorized personnel **only**.



FRAME 4

Emission Control Engine Details-

TR6

1. Exhaust valves stellite faced to maintain effective valve seating between servicing intervals.
2. Cylinder head compression 7.75 : 1
3.

Camshaft	Opens	Closes
Intake valve	18 deg. B.T.D.C.	58 deg. A.B.D.C.
Exhaust valve	58 deg. B.B.D.C.	18 deg. A.T.D.C.
4. Distributor has centrifugal advance and vacuum retard.
5. Carburetter: Twin Stromberg 175 CDSE (V). Top adjustment.

Details:

- (a) Biased type spring-loaded needle (towards air cleaner).
- (b) Mixture needle adjustment through top of carburetter (for approved personnel only-not available to owners).
- (c) Temperature compensator for mixture.
- (d) Deceleration by-pass valve mounted on carburetter.
- (e) Trim screw for very fine mixture adjustment.
- (f) Float-chamber vent valve.
6. Spark plugs, Champion N9Y.

Emission Control System- Ignition and Carburetter Settings-

TR6

Idle speed (rev/min)	800 to 850
Ignition timing, static	10 deg. B.T.D.C.
Ignition timing at idle	4 deg. A.T.D.C.
Distributor part number: Early cars	218100 (Lucas)
Later cars	TKCO 517 (Lucas)
Dwell angle	34 to 37 deg.
Basic carburetter settings	Fixed
Idle CO level, engine warm	0.5 to 2.5%
Equivalent air/fuel ratio at idle (approx.)	14.4 : 1 to 13.6 : 1

TR6 Distributor Part Number 218100 (Early Cars)

Centrifugal advance (check at decelerating speeds)

Distributor Speed rev/min	Degrees of Distributor Advance	
	Minimum	Maximum
Below 400	No advance to occur	
575	0	2
700	1.25	3.5
850	3	5
1,400	6	9
1,850	9	11
2,500	12	14

TR6 Distributor Part Number TKCO 517 (Later Cars)

Centrifugal advance (check at decelerating speeds)

Distributor Speed rev/min	Degrees of Distributor Advance	
	Minimum	Maximum
Below 400	No advance to occur	
500	0	1
750	2	4
850	3	5
1,200	6	8
1,650	8	10
1,850	9	11

Vacuum Retard (Early and Later Cars)

No retard before 2 1/2 inHg. Fully retarded, 7+/- 1 deg. at 10 inHg.

Caution: U.S. Federal Standards
Control of Air Pollution (see note on [\[6\]](#))



FRAME 5

Emission Control Engine Details-

Stag

1. Exhaust valve head material is 21/4N.
2. Cylinder head compression 7.75 : 1
3.

Camshaft	Opens	Closes
Intake valve	16 deg. B.T.D.C.	56 deg. A.B.D.C.
Exhaust valve	56 deg. B.B.D.C.	16 deg. A.T.D.C.
4. Distributor has centrifugal advance and vacuum retard.
5. Carburetter: Twin Stromberg 175 CDSE (V). Top adjustment.

Details:

- (a) Biased type spring-loaded needle (towards air cleaner).
- (b) Mixture needle adjustment through top of carburetter (for approved personnel only-not available to owners).
- (c) Temperature compensator for mixture.
- (d) Deceleration by-pass valve mounted on carburetter.
- (e) Trim screw for very fine mixture adjustment.
- (f) Float-chamber vent valve.
6. Spark plugs, Champion N11Y.

Emission Control System- Ignition and Carburetter Settings-

Stag

Idle speed (rev/min)	800 to 850
Ignition timing, static	10 deg. B.T.D.C.
Ignition timing at idle	4 deg. A.T.D.C.
Distributor part number	218977
Dwell angle	29 1/2 to 33 1/2 deg.
Basic carburetter settings	Fixed
Idle CO level, engine warm	0.5 to 2.5%
Equivalent air/fuel ratio at idle (approx.)	14.4 : 1 to 13.6 : 1

Stag Distributor Part Number 218977

Centrifugal advance (check at decelerating speeds)

Distributor Speed rev/min	Degrees of Distributor Advance	
	Minimum	Maximum
Below 400	No advance to occur	
500	0	2
700	2	5
1,000	7	9
1,500	9	11
2,000	11	13

Vacuum Retard

No retard before 2 1/2 inHg. Fully retarded, 7 +/- 1 deg. at 10 inHg.

Caution: U.S. Federal Standards
Control of Air Pollution

Unauthorized interference with, or adjustment to, distributor or carburetter settings will almost certainly result in vehicles failing to meet the legal requirements in respect of air pollution.

Adjustments to these setting must be made by authorized personnel **only**.

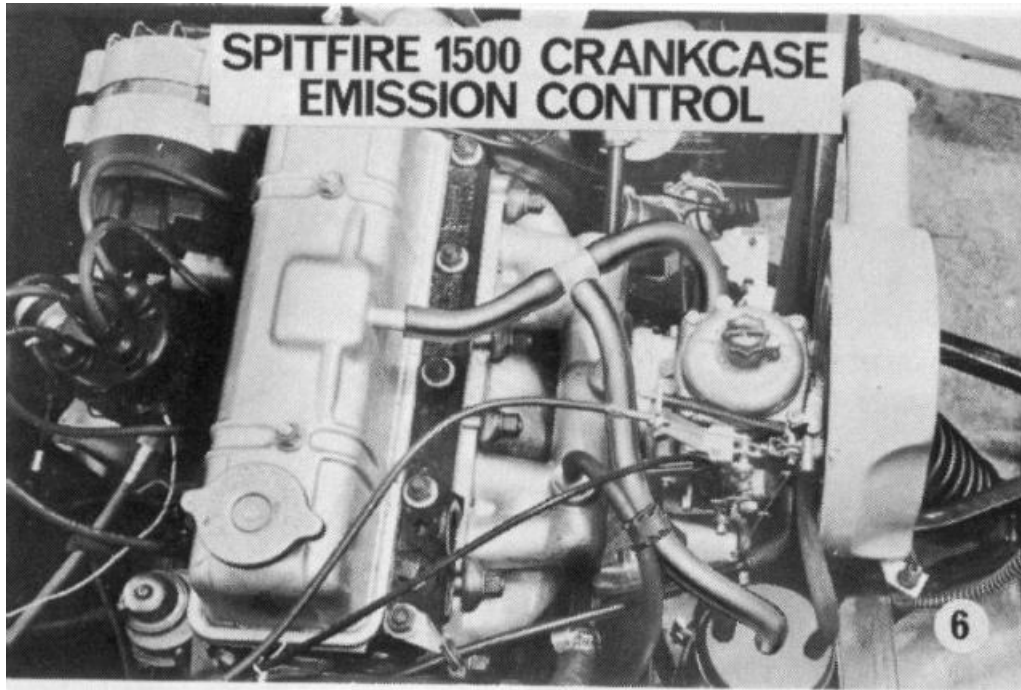

FRAME 6

Part 2

Crankcase Emission Control System

Spitfire 1500

Crankcase fumes and blow-by gases are drawn through a gauze filter/flame trap in the rocker cover via a pipe to the constant depression area of the carburetter and mixed with the in-going petrol/air mixture.

The constant depression is also utilized to cleanse the activated canister of petrol vapour via the purge line which is integrated with the crankcase emission system.

NOTE: The oil filler cap is sealed and the dipstick seal must be in position.

Every 12,000 miles (20000 km) the rocker cover, crankcase emission pipes, tee piece restrictor and purge pipe must be cleaned and inspected for deterioration. Renew pipes as necessary.

If excessive contamination is found in the system it will be necessary to clean the carburetter air valve and body.

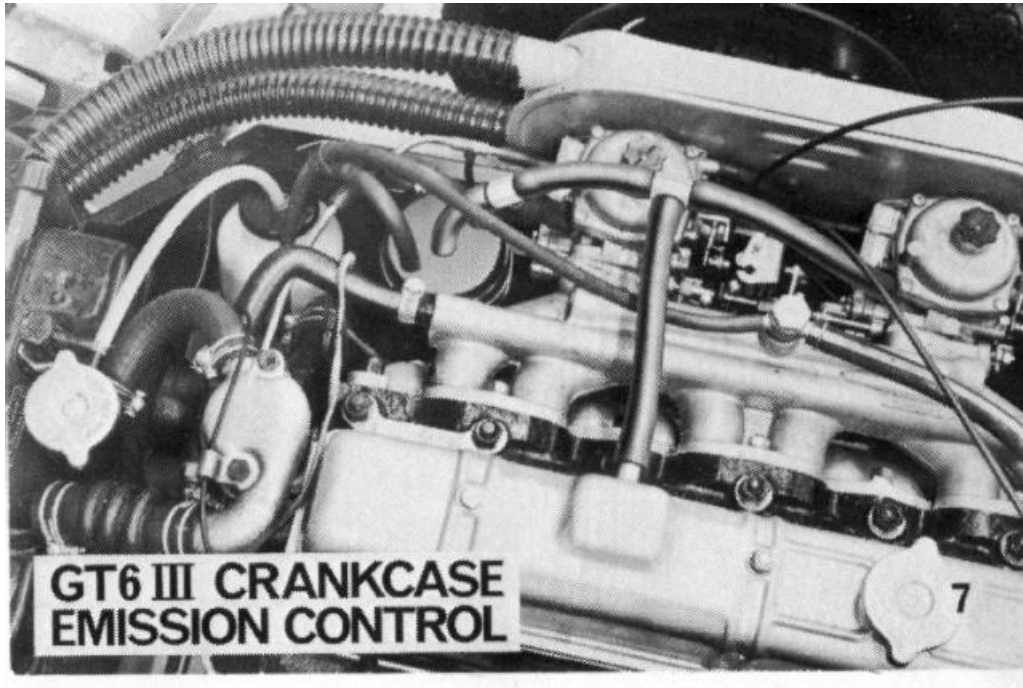

FRAME 7

Crankcase Emission Control System

(Twin Carburetters)

In the above and two succeeding frames are shown the crankcase emission control systems for the Triumph GT6 Mk. III, TR6 and Stag.

Crankcase fumes and blow-by gases are drawn through a gauze filter/flame trap in the rocker cover via a pipe to the constant depression area of the carburetter and mixed with the in-going petrol/air mixture.

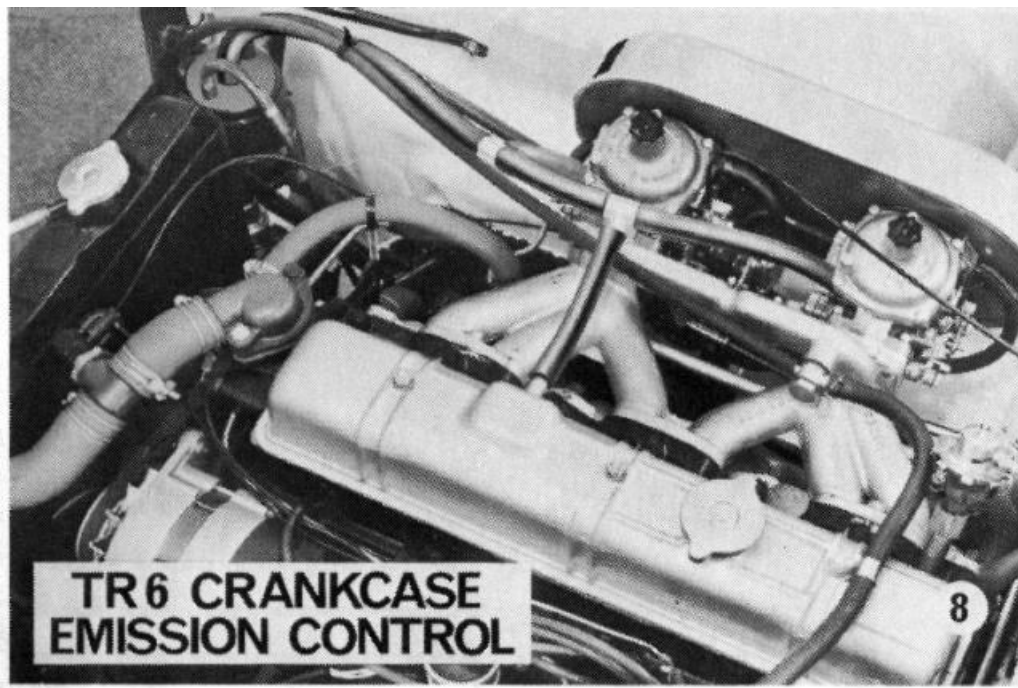

FRAME 8

The constant depression is also utilized to cleanse the activated canister of petrol vapour via the purge line which is integrated with the crankcase emission system.

NOTE: The oil filler cap is sealed and the dipstick seal must be in position.



FRAME 9

Every 12,000 miles (20000 km) the rocker cover, crankcase emission pipes, tee piece restrictor and purge pipe **MUST** be cleaned and inspected for deterioration. Renew pipes as necessary.

If excessive contamination is found in the system it will be necessary to clean the carburettor air valve and body.

EVAPORATION LOSS CONTROL SYSTEM SPITFIRE 1500

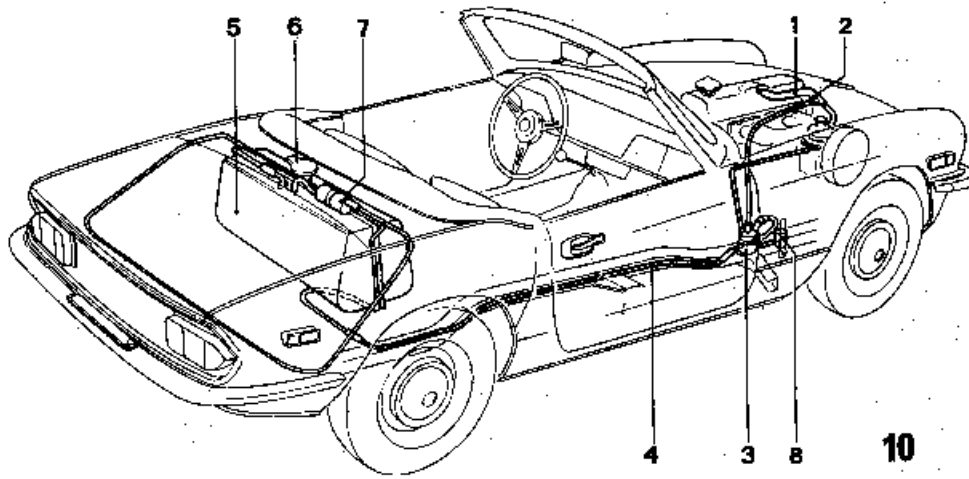

FRAME 10

Annotations for Frame.

- | | |
|-------------------------|----------------------------|
| 1. Crankcase purge line | 5. Fuel tank, limited fill |
| 2. Canister purge line | 6. Sealed fuel filler cap |
| 3. Canister | 7. Vapour separator |
| 4. Vapour feed line | 8. Anti run-on valve |

Part 3

Evaporation Loss Control Systems

Fuel loss on cars, through evaporation, is effectively controlled to within the limits defined in the regulations for 1973 by the systems shown in the above and three succeeding frames.

Description

The evaporative control systems incorporated on the 1973 Spitfire 1500, GT6 Mk. III, TR6 and Stag models use an activated charcoal canister through which the fuel tank and carburettor float-chambers are vented.

EVAPORATION LOSS CONTROL SYSTEM GT6 III

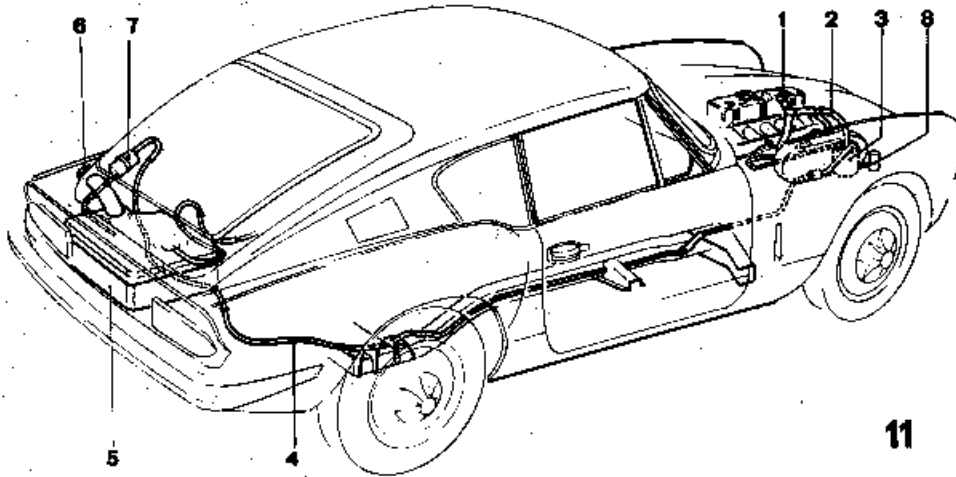

FRAME 11

Annotations for Frame.

- | | |
|-------------------------|----------------------------|
| 1. Crankcase purge line | 5. Fuel tank, limited fill |
| 2. Canister purge line | 6. Sealed fuel filler cap |
| 3. Canister | 7. Vapour separator |
| 4. Vapour feed line | 8. Anti run-on valve |

The fuel tank filler tube extends into the tank, preventing complete filling. There is sufficient space left in the fuel tank for the fuel to expand in hot weather.

The fuel tank filler cap is sealed.

The piping from the fuel tank incorporates a vapour separator which allows for a fuel 'splash surge' condition, thus trapping the fuel and allowing a drain-back into the tank and preventing the charcoal canister becoming saturated. Fuel is discouraged from entering the piping to the charcoal canister even during pressure filling of the fuel tank, by means of an air restrictor valve situated near the charcoal canister.

EVAPORATION LOSS CONTROL SYSTEM TR6

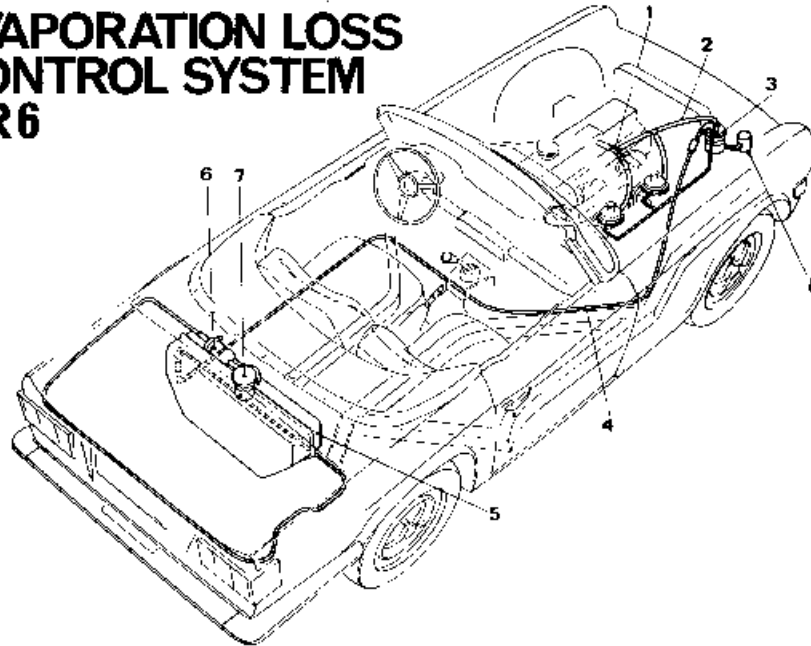

12

FRAME 12

Annotations for Frame.

- | | |
|-------------------------|----------------------------|
| 1. Crankcase purge line | 5. Fuel tank, limited fill |
| 2. Canister purge line | 6. Vapour separator |
| 3. Canister | 7. Sealed fuel filler cap |
| 4. Vapour feed line | 8. Anti run-on valve |

The fuel tank filler tube extends into the tank, preventing complete filling. There is sufficient space left in the fuel tank for the fuel to expand in hot weather.

The fuel tank filler cap is sealed.

The piping from the fuel tank incorporates a vapour separator which allows for a fuel 'splash surge' condition, thus trapping the fuel and allowing a drain-back into the tank and preventing the charcoal canister becoming saturated. Fuel is discouraged from entering the piping to the charcoal canister even during pressure filling of the fuel tank, by means of an air restrictor valve situated near the charcoal canister.

EVAPORATION LOSS CONTROL SYSTEM STAG

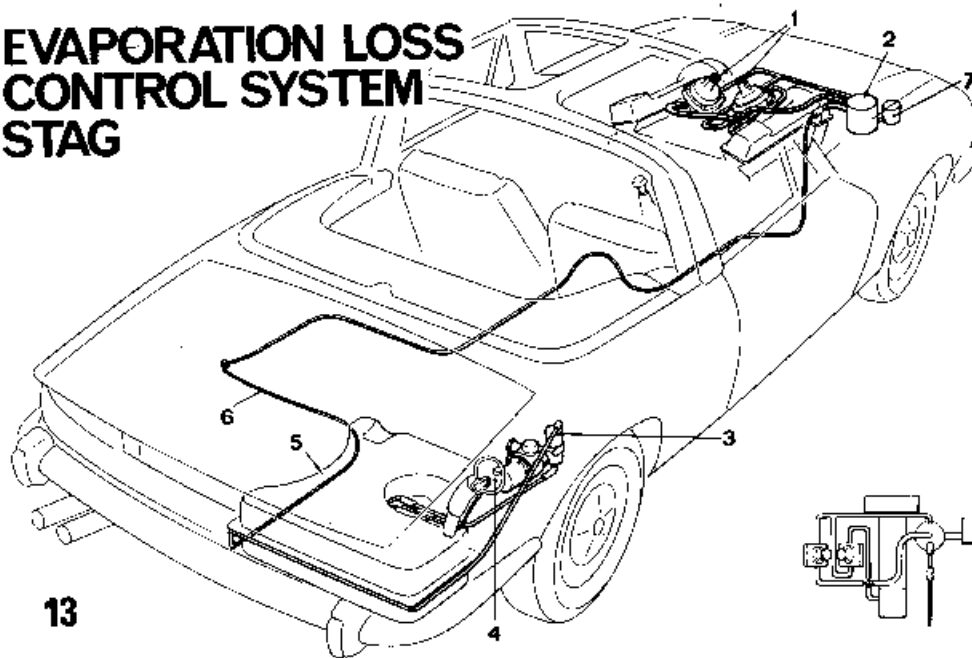

13

FRAME 13

Annotations for Frame.

- | | |
|---------------------------|----------------------------|
| 1. Carburettors | 5. Fuel tank, limited fill |
| 2. Canister | 6. Vapour feed line |
| 3. Vapour separator | 7. Anti run-on valve |
| 4. Sealed fuel filler cap | |

The canister containing the activated charcoal is vented to atmosphere via a filter. The activated charcoal is purged, and fuel vapour build-up prevented, by a connection from the canister to the constant depression area of the carburettor.

As fuel is used, air is drawn into the fuel tank via the activated charcoal filter and piping circuit.

No servicing is required for the activated charcoal canister but the complete canister should be changed every 48,000 miles (80000 kilometers).

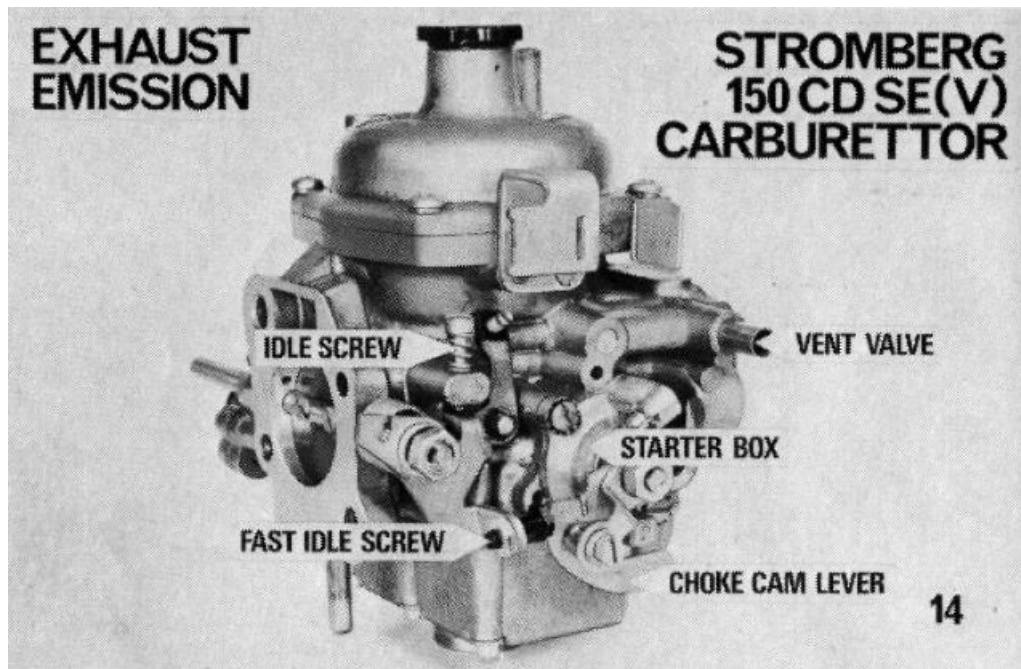

FRAME 14

Part 4

Stromberg CDSE (V) Carburetter

The Stromberg CDSE (V) carburetter, which is a constant depression carburetter, operates on the principle of varying the effective area of the choke and jet orifice, in accordance with throttle opening and engine speed and load.

During manufacture, all the carburetters are subjected to a 'flow' test. During this test the carburetters for a specific application are matched exactly in respect of 'flow' characteristics against a 'master' carburetter. The flow test simulates air passing through the carburetter.

NOTE: It is essential that neither the body or air valve is interchanged with components of another carburetter.

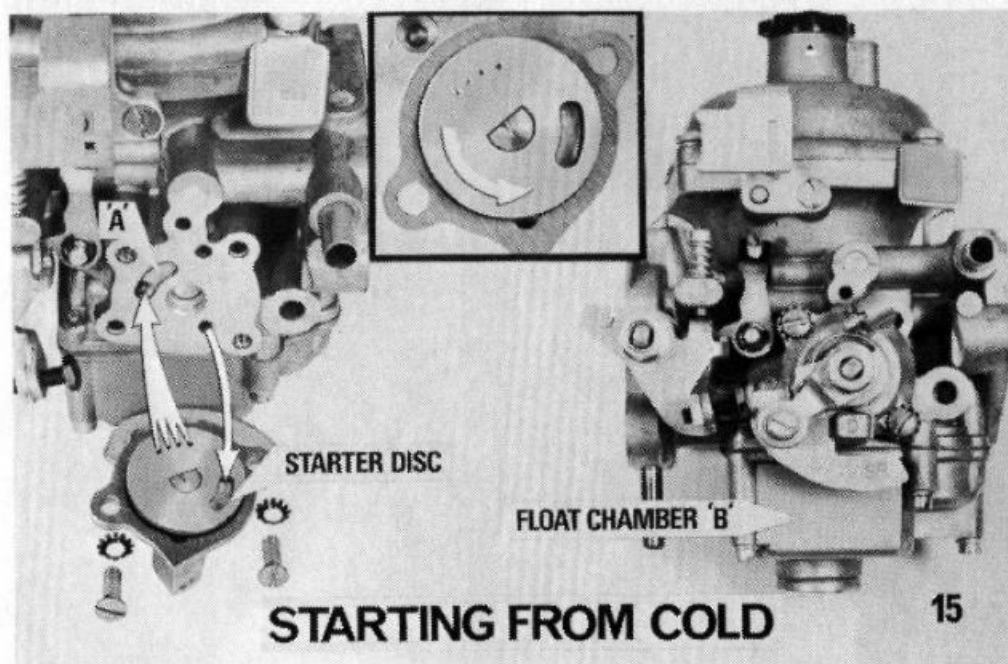

FRAME 15

Starting From Cold

The choke control operates a lever on the side of the carburetter which rotates a disk in the starter device. A series of different diameter holes are drilled in the starter disc.

In the full choke, rich position, all the holes will be in line with the starter circuit segment 'A' in the illustration.

Petrol is drawn from the float-chamber 'B', via a drilling, into the starter device and the mixture is then metered via the holes in the starter disc into the throttle body between the air valve and throttle butterfly. Simultaneously, a cam on the starter lever will open the throttle beyond the idle position, according to the position of the fast idle screw, to prevent the engine stalling when the engine is cold.

As the choke control is gradually released, fewer and smaller holes will provide the petrol feed from the float-chamber, therefore progressively weakening the mixture strength to a point where all the holes in the starter disc are blanked off and the idle circuit of the carburetter is in action.

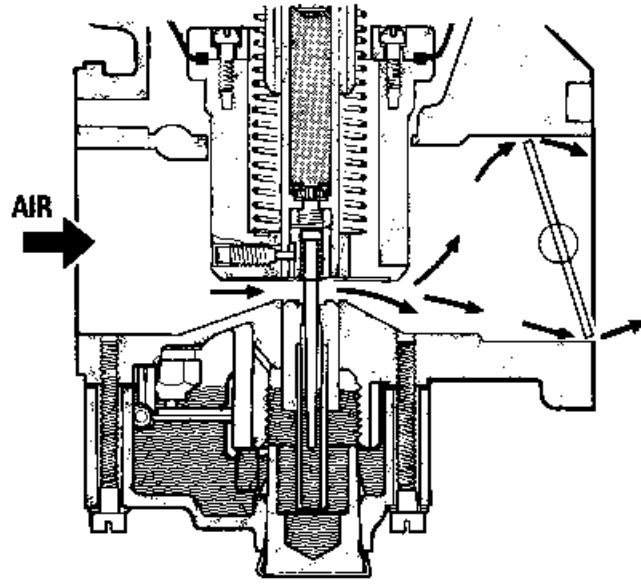

IDLING CONDITION

16

FRAME 16

Normal Running

Fuel for idling is provided by the jet orifice, the amount being controlled by the jet/needle relationship established during manufacture.

The idle speed is regulated by adjustment of the slow running screw, which limits the closure of the throttle butterfly when the accelerator pedal is released.

The jet/needle relationship also governs the mixture strength throughout the engine load and speed range.

The jet needle is biased so that the needle is permanently in contact with one side of the jet, to ensure a consistent fuel flow from the needle profile.

CAUTION: No attempt should be made to alter the jet/needle relationship.

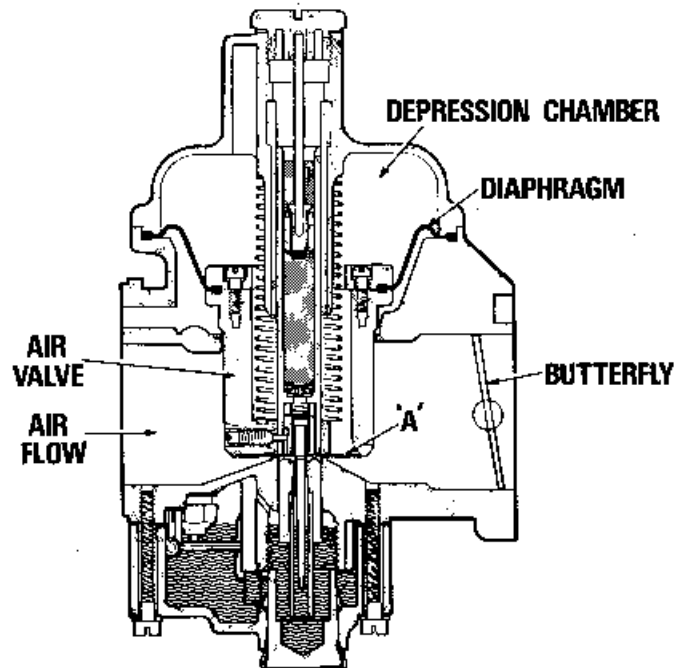

17

FRAME 17

When the throttle is opened, air flow under the air valve increases and a temporary rise in the mixing chamber depression is transferred via drilling 'A' in the air valve to the depression chamber which is sealed from the main body by a diaphragm.

The pressure on the depression chamber side of the diaphragm is lower than on the air valve side, and this causes the air valve to lift.

As the air valve rises, it withdraws the tapered metering needle, which is secured to the air valve, from the jet orifice so that the fuel flow is increased in proportion to the greater air flow.

The amount that the air valve rises is governed by the engine speed and load.

The carburettor needle is machined to very close limits and provides the correct petrol/air mixture ratio for all engine speeds and loads as required by the engine manufacturers.

To maintain correct tolerance in respect of exhaust emissions, it is essential that only the recommended needle is used.

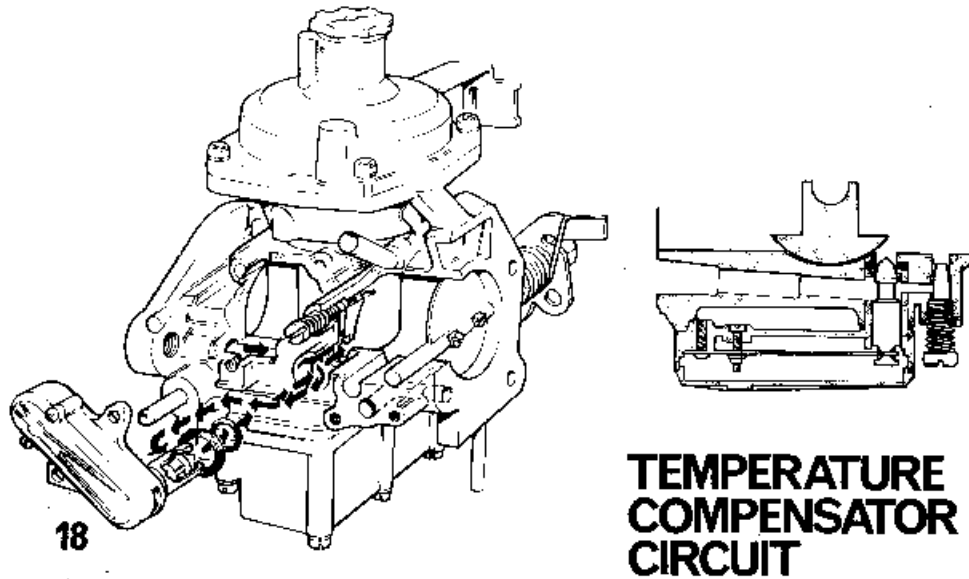

FRAME 18

The Temperature Compensator

Emission testing has shown the need for a temperature compensator to cater for minor mixture strength variations caused by heat transfer to the carburettor castings. This demonstrates the extraordinary precision demanded by exhaust emission requirements.

The temperature compensator allows some of the air which is passing through the carburettor to by-pass the bridge section and be bled into the mixing chamber. A tapered plug on the end of a bi-metal strip regulates the amount of air introduced into the mixing chamber and is related to the heat 'sensed' by the bi-metal strip. The temperature compensator is sealed in two places to avoid leakage at the joint with the main body.

As the temperature of the carburettor rises and the bi-metal strip is actuated, air is bled into the mixing chamber which causes the air valve to ride in a lower position, in order to maintain depression on its downstream side. The effect of this is to give a smaller fuel flow and weaken the mixture.

In the cold position, no air is passed through the temperature compensator.

NOTE: THIS ASSEMBLY IS PRE-SET AND MUST NOT BE ADJUSTED. If a malfunction of the component is suspected and the tapered plug is free when carefully tested by hand, the compensator assembly must be changed.

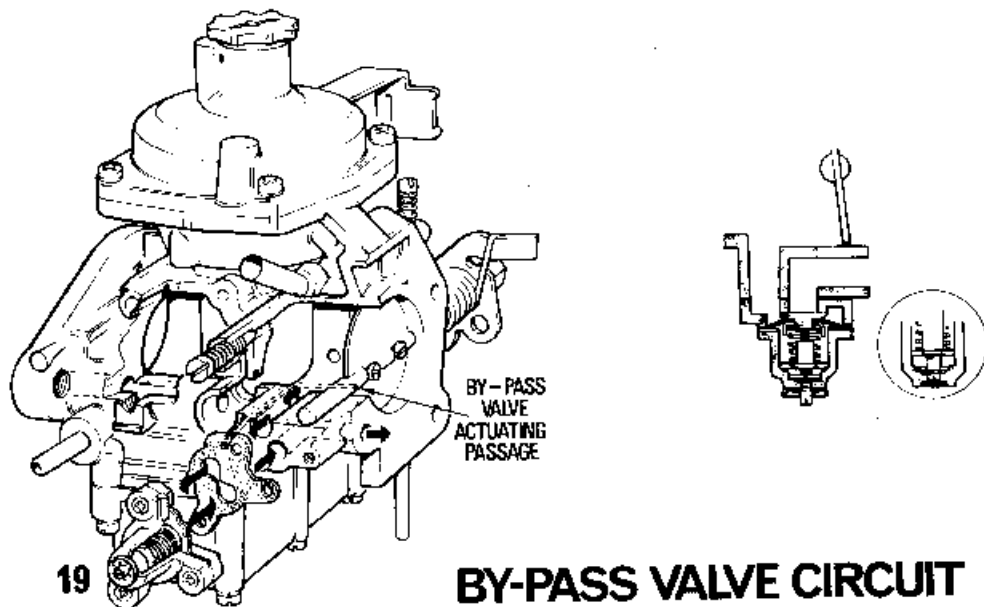

FRAME 19

By-Pass Valve

During periods of engine over-run, high emissions of hydrocarbons and carbon monoxide will occur due to a rich mixture in the combustion chamber contaminated by exhaust gases, which is incombustible due to a lack of oxygen.

To counter the above condition a by-pass valve is fitted to the carburettor. The by-pass valve opens when a high inlet manifold depression overcomes the tension of the valve diaphragm spring, allowing extra fuel/air to feed from the mixing chamber of the carburettor via a passage to the downstream side of the butterfly.

The extra fuel/air mixture fed into the combustion chamber allows complete combustion to take place.

The by-pass valve can only be serviced as a complete unit and should be adjusted as described in [Frame 42](#) .

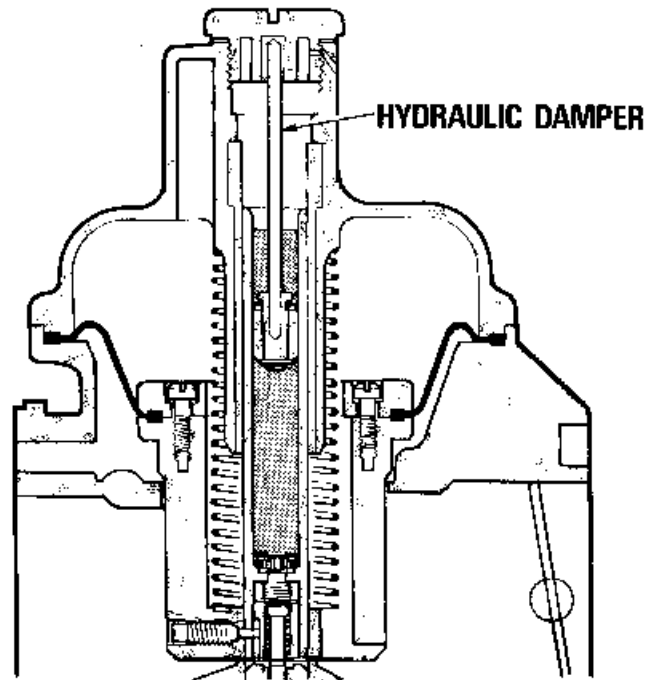

20

FRAME 20

Hydraulic Damper

At any point in the throttle range a temporary enrichment is needed when the throttle is suddenly opened. A hydraulic damper is fitted inside the hollow guide rod of the air valve.

The guide itself is filled with 'Zenith Lube Pack' or S.A.E. 20 engine oil to within 1/4 inch of the end of the rod.

When the throttle is suddenly opened the immediate upward motion of the piston is resisted by the damper. For this brief period a temporary increase in the depression over the jet orifice is achieved and the mixture is enriched. Downward movement of the air valve is assisted by a coil spring.

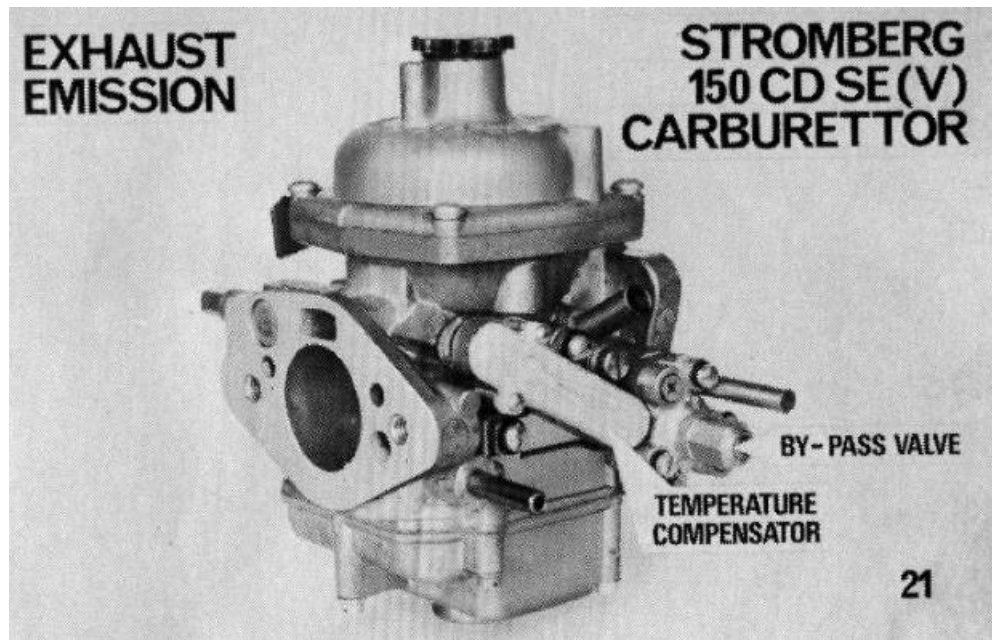

FRAME 21

Part 5

Stromberg Carburetter Servicing

All Stromberg carburetters used on 1973 specification Triumph models for the U.S.A. have the following features.

Air/fuel mixture adjustment by special tools inserted through the top of the carburetter.

The needle, which is spring-loaded, is biased towards the air cleaner.

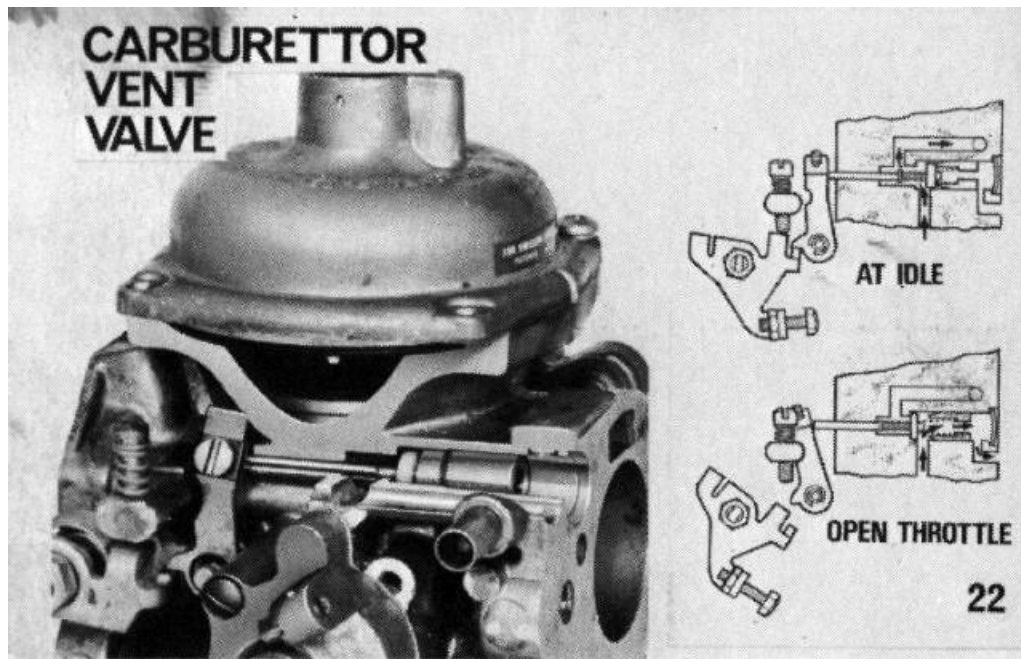

FRAME 22

Carburettor Vent Valves

All emission controlled cars in the 1973 Triumph range have vent valves on the carburettors. The vent valves are operated by a lever on the throttle spindle.

When the engine is idling, or stationary, these valves are in the position in illustration 'A', which allows the float-chamber to vent to the activated charcoal through a tube.

When the throttles are opened, the vent valves close off the vent passages and the float-chamber outlets are vented internally through the drillings to the carburettors side of the air cleaner and any fumes consumed by the engine.



FRAME 23

Adjusting the Carburettor Vent Valve

NOTE: It is most important that the vent valve is correctly set on each carburettor, otherwise the operation of the run-on control valve may be affected.

Before any adjustment to the vent valves takes place it is essential that the engine slow running is set to 800 to 850 rev/min.

Stop the engine and remove the existing vent valve tubing from the carburetters (on the Spitfire 1500 cars only one carburettor is fitted).

Attach a separate piece of tubing to the vent valve tube on the body of the carburettor, see illustration.

Blow through the tube, and at the same time operate the lever operating the vent valve on the side of the carburettor.

By operating the lever a sudden restriction can be felt while blowing down the tube. This will allow the mechanic to 'feel' the vent valve operating.

Release the lever and allow the mechanism to return to the condition when at engine idle.

Blow through the tube again and if no restriction is apparent the vent valve is in a satisfactory position. If, however, a restriction is felt, turn the adjustment screw anti-clockwise until the restriction just disappears. The valve is now correctly set.

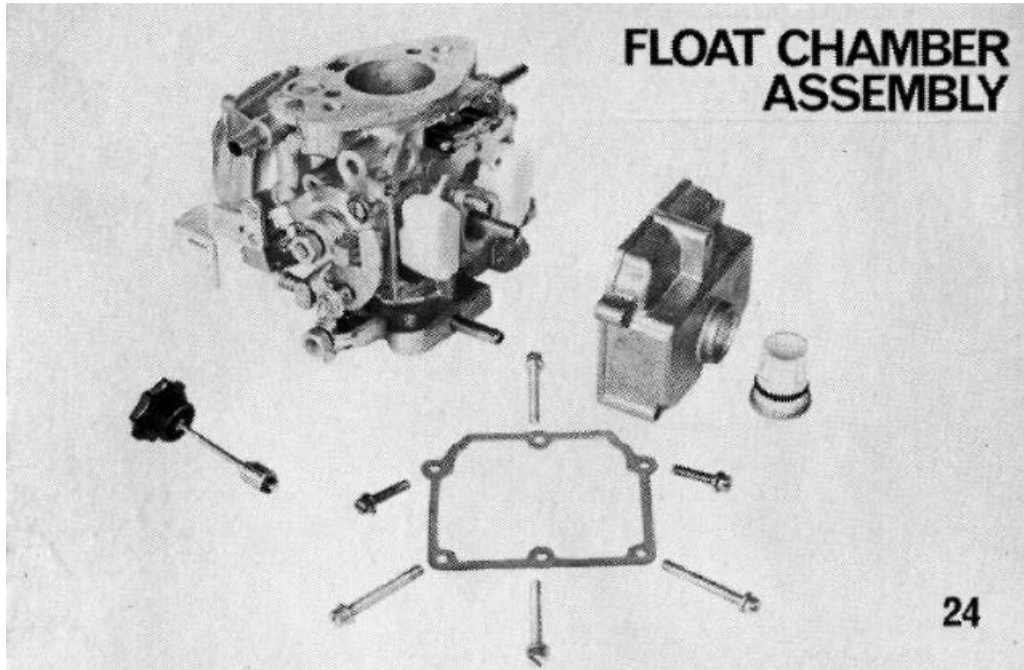

FRAME 24

Float-Chamber Assembly

1. Service each carburettor separately to avoid interchanging components. Remove the damper from the top of the carburettor and drain off the oil from the air valve guide tube.
2. Remove the six float-chamber attachment screws and washers. Carefully remove the float-chamber and gasket and drain off the fuel.

NOTE: It is not necessary to remove the neoprene plug from the bottom of the float-chamber unless there has been a leak from this point and the 'O' ring has to be replaced.

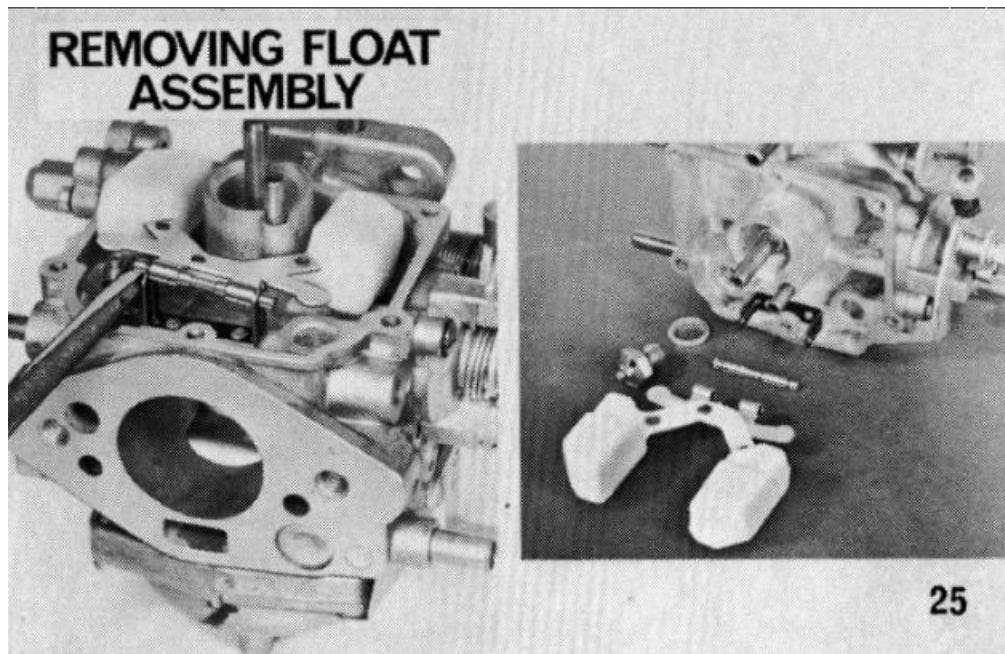

FRAME 25

Float-Chamber Assembly

3. Remove the floats by carefully levering up at either end of the float pivot pin as shown. Avoid any force which might distort the float assembly as this would upset the fuel level.
4. Remove the float-chamber needle valve and washers.

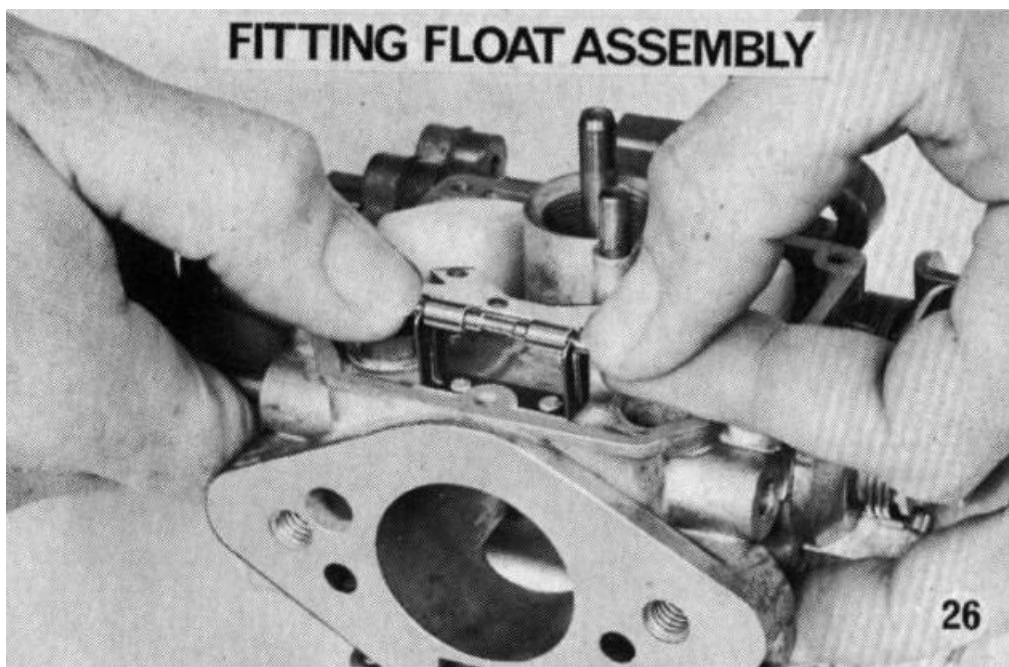

FRAME 26

Wash all parts thoroughly and dry with compressed air, NOT RAG. Check the needle valve seating.

Fit a new float-chamber needle valve washer, screw the needle valve securely into the carburetor body.

Replace the float by pressing on the ENDS of the float pivot pin. To prevent distortion of the pivot pin, avoid pressure at the centre.

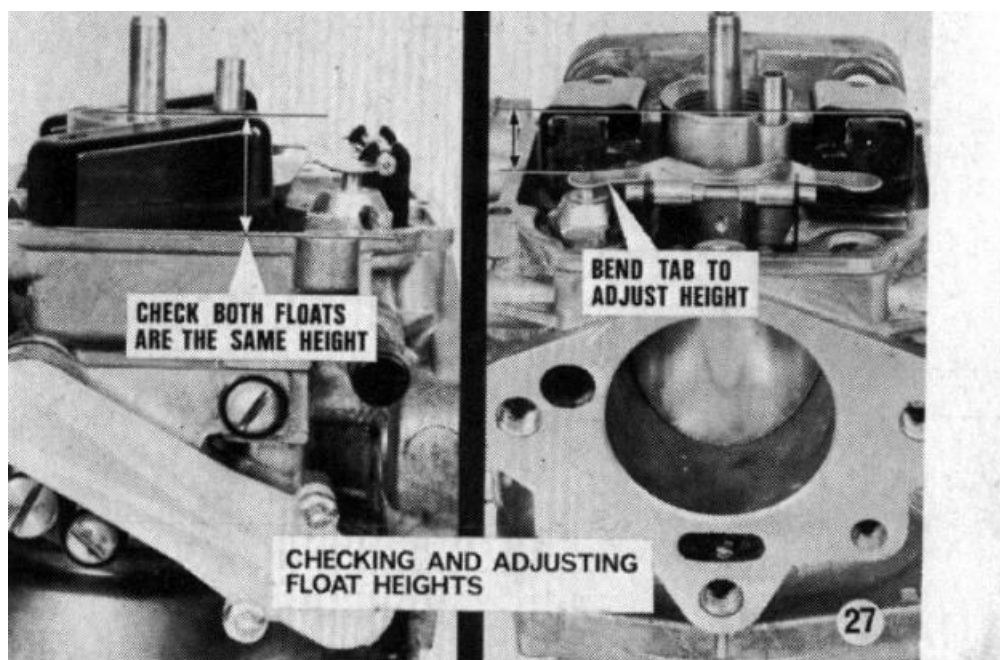

FRAME 27

To ensure correct fuel level, check the distance between the float-chamber flange without gasket, to the highest point of each float. Correct measurement 16.0 to 17.0 mm.

NOTE:

- A. The height of both floats must be the same.
- B. If adjustment is necessary, bend the tab over the needle valve until correct measurement is obtained, ensuring that the tab contacts the needle at right angles to prevent any possibility of sticking.

For speed and accuracy it is advisable to make a gauge to check float height.

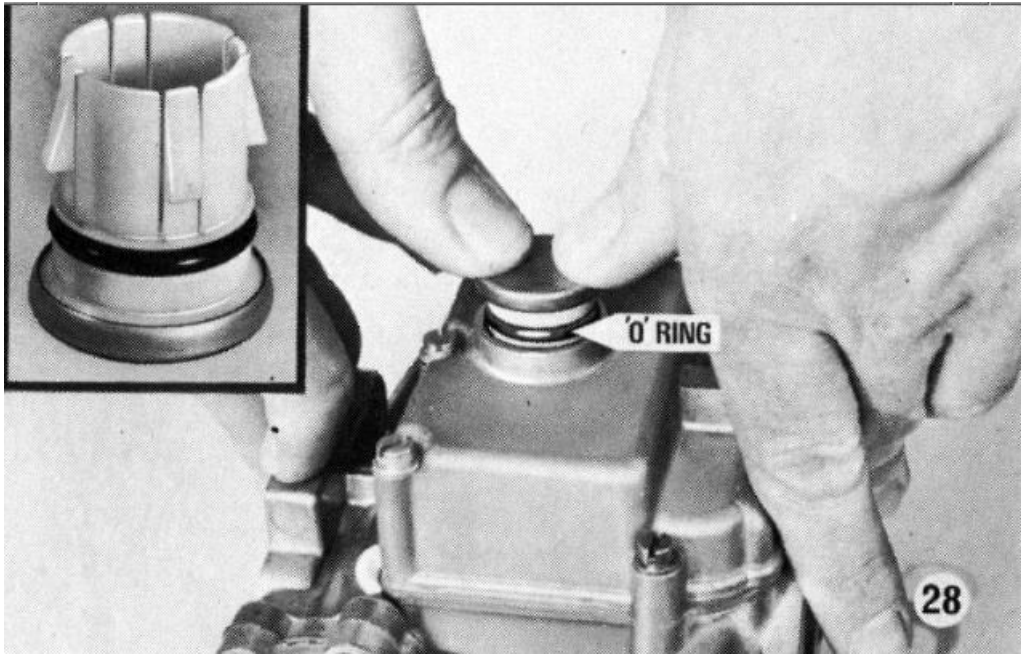

FRAME 28

Fit a new float-chamber gasket, refit and secure with six screws and washers.

NOTE: Two screws are short and should be fitted to positions shown in illustration.

If the float-chamber neoprene plug has been removed, fit a new 'O' ring and carefully press into the float-chamber cover as shown above.

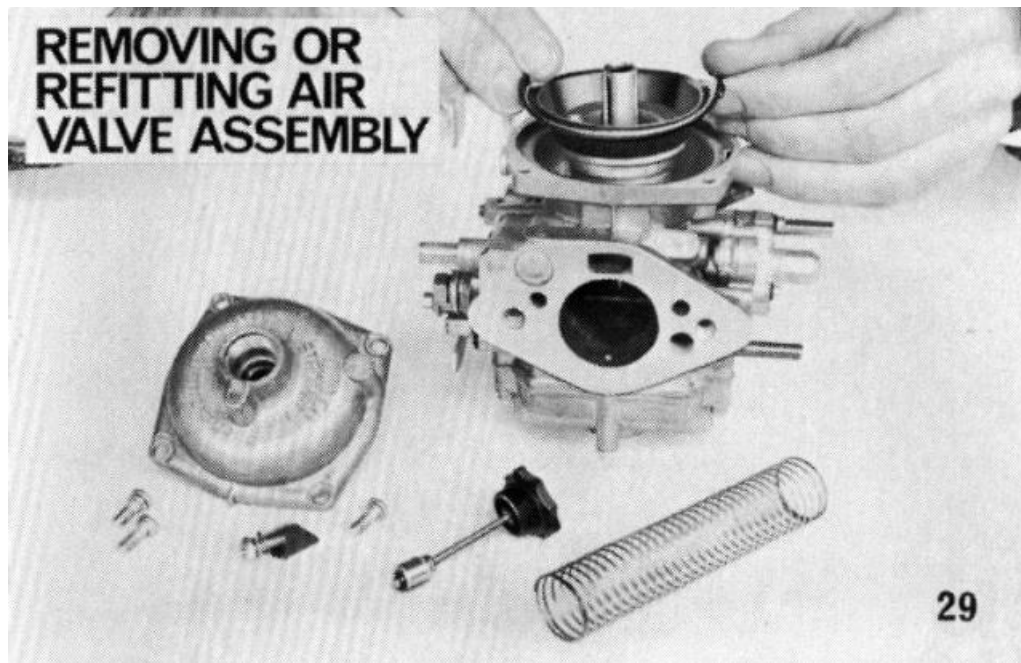

FRAME 29

Air Valve Assembly

Remove the air valve damper.

With a [Poizidriv](#) screwdriver remove the four cover screws.

Before lifting the cover, note the position of the bulge on the housing neck. It faces towards the air intake.

Remove the cover and spring.

It is **IMPORTANT** to lift out the air valve assembly by holding the diaphragm as shown. Avoid touching the air valve stem, as moisture from the fingers will cause corrosion.

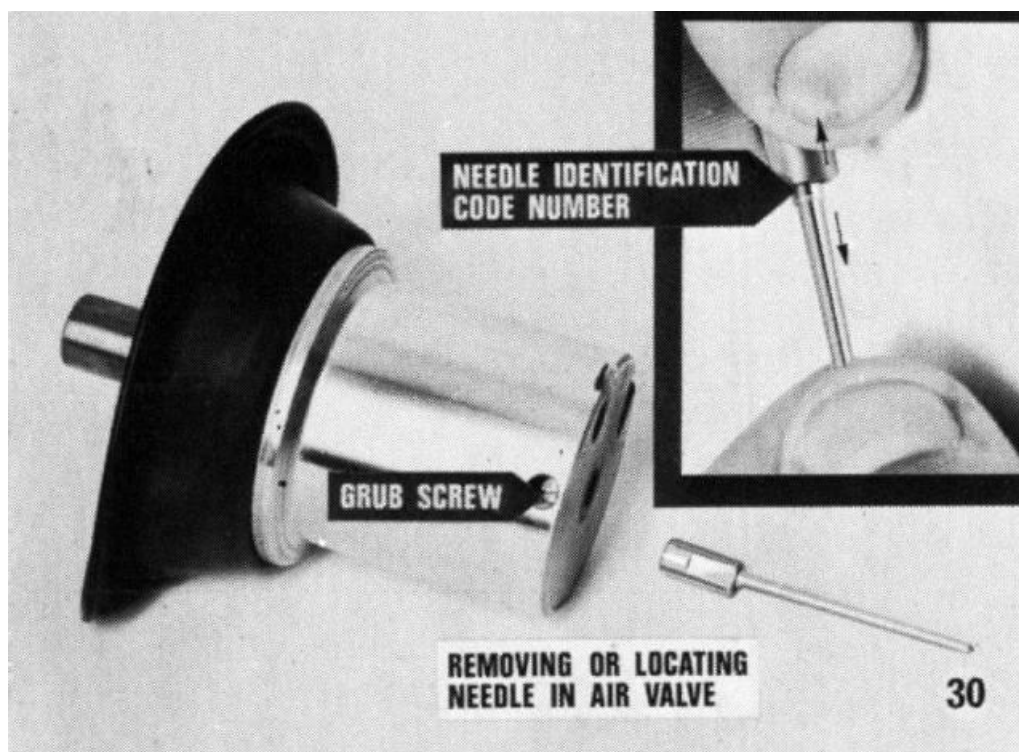

FRAME 30

Removing Needle from Air Valve

Slacken the grub screw, and using the special tools in the air valve tube, unscrew the spring-loaded needle assembly and keep it in a safe place while changing the diaphragm.

Needle Identification

The code number is found on the shank of the needle. Pull the needle against spring pressure as shown by the arrows to read the code (see inset).

NOTE: The needle and its spring-loaded housing are an assembly and cannot be obtained separately.

The code numbers for 1973 specification needles are as follows:

Stag	B1AQ	Spitfire 1500	B5CH
TR6	B1AF	GT6 Mk. III	N5CF

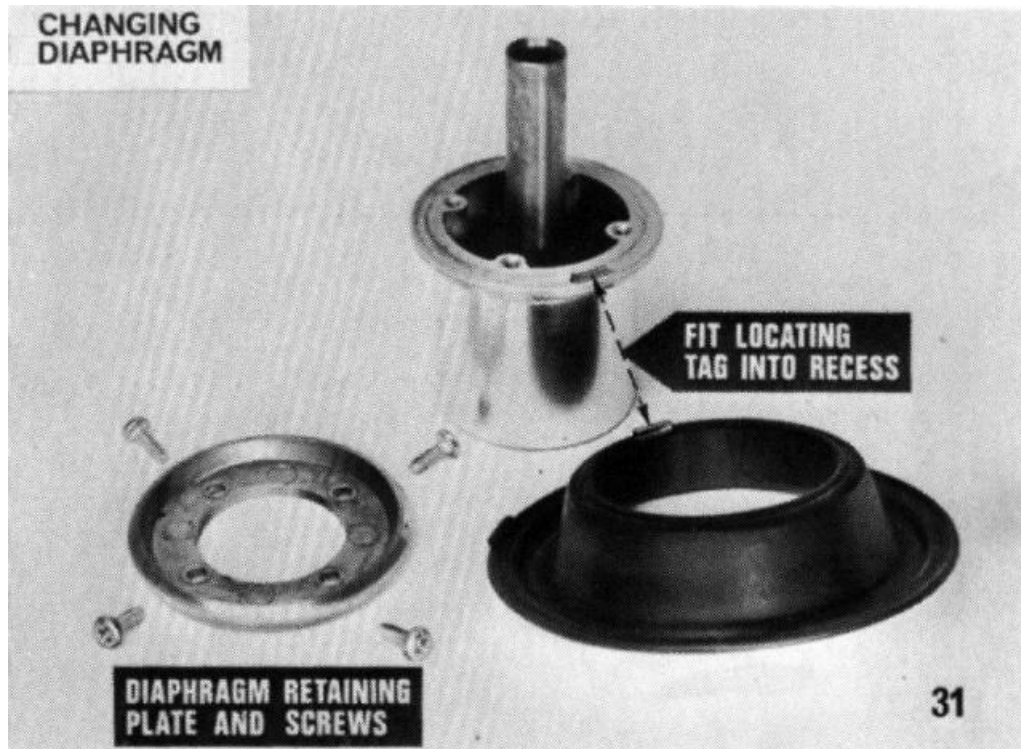

FRAME 31

Changing the Diaphragm

1. Remove the screws with the special-type screwdriver and remove the retaining plate.
2. Lift off the diaphragm.

Fitting a New Diaphragm

1. Position the moulded tag in the air valve recess as shown.
2. Fit the retaining plate and four screws finger-tight.
3. Check that the diaphragm is seating properly all round.
4. Tighten the screws fully.

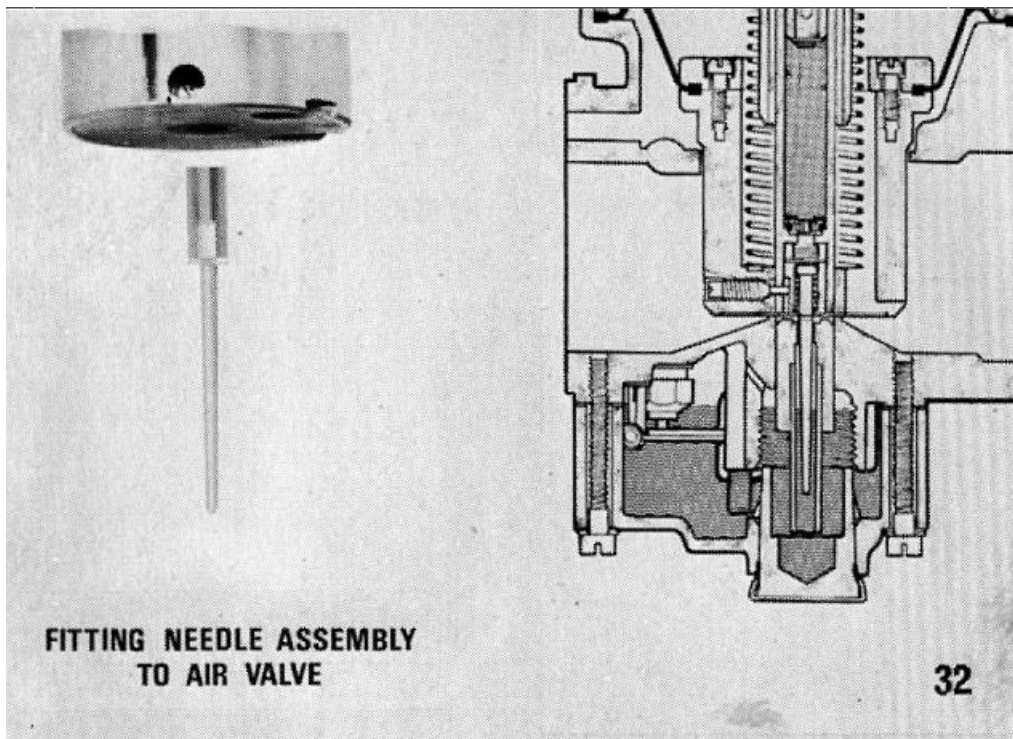

FRAME 32

Fitting Needle Assembly to Air Valve

1. Check the needle assembly spring action (when fitted the needle bias faces the air cleaner).
2. Offer up the needle assembly to the air valve.
3. Fit the special needle adjustment tools in the air valve tube and turn the tool approximately one-and-a-half turns in a clockwise direction.
4. Continue to rotate the needle until the slot in the needle housing is in line with the air valve grub screw. Fully tighten the grub screw.
5. The grub screw does not hold the needle in position, but acts as a locating peg and prevents the needle assembly from rotating during adjustment.

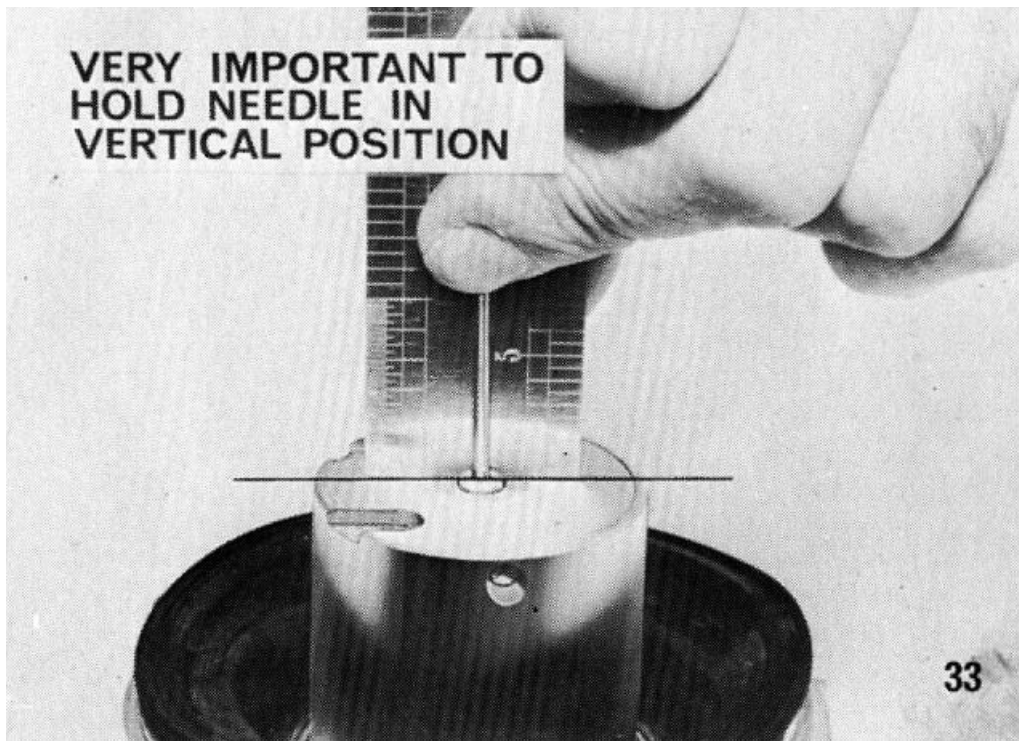

FRAME 33

Correct Positioning of Needle

It is most important that the needle is adjusted to the mid condition before fitting to the carburetter and final adjustment using an air fuel meter.

Using tools previously described, adjust the needle until the face of the nylon washer is below the surface of the air valve.

Hold a steel rule in the position shown above with the needle against it and held in the vertical position against spring pressure.

Adjust the needle upwards until the face of the nylon washer just contacts the steel rule.

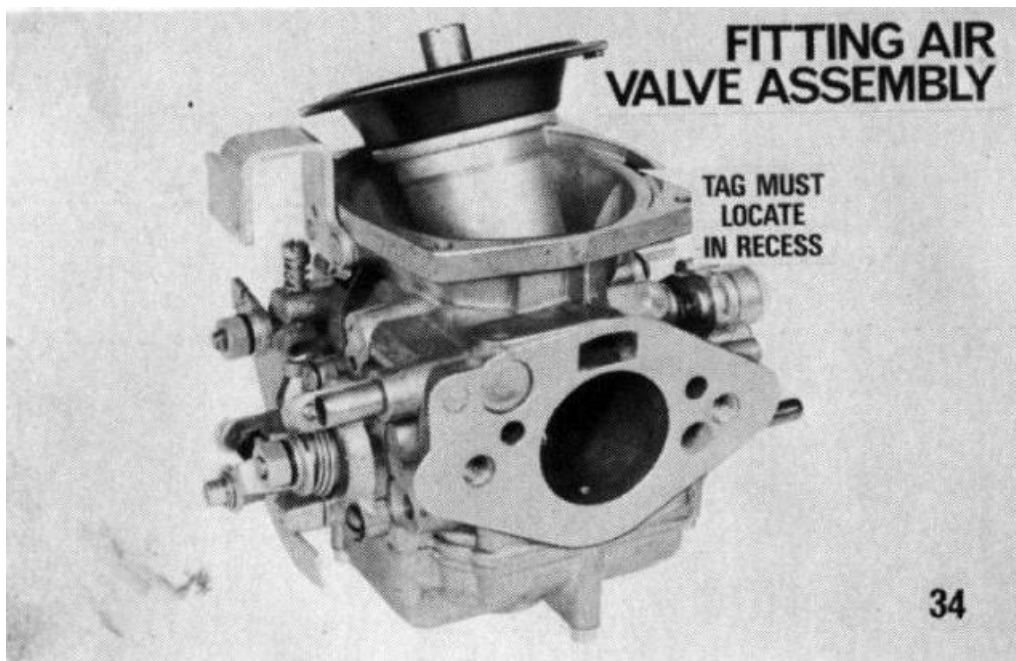

FRAME 34

Fitting Air Valve Assembly into Carburetters

1. Hold the assembly by the diaphragm as described in [Frame 29](#) . Avoid contaminating the valve stem by unnecessary handling.
2. Carefully insert the needle end into the jet.
3. Lower the assembly into position.
4. Check that the diaphragm tag is located in the recess as shown and the beaded edge is resting in the groove evenly all the way round.
5. Fit the air valve cover and evenly tighten the four screws with the [Pozidriv](#) screwdriver.

NOTE: If the screws are not fully tightened it is possible for the air valve to stick. Fill up with the correct grade of oil to within 1/4 in (6 mm) of the top of the damper tube and refit the damper.

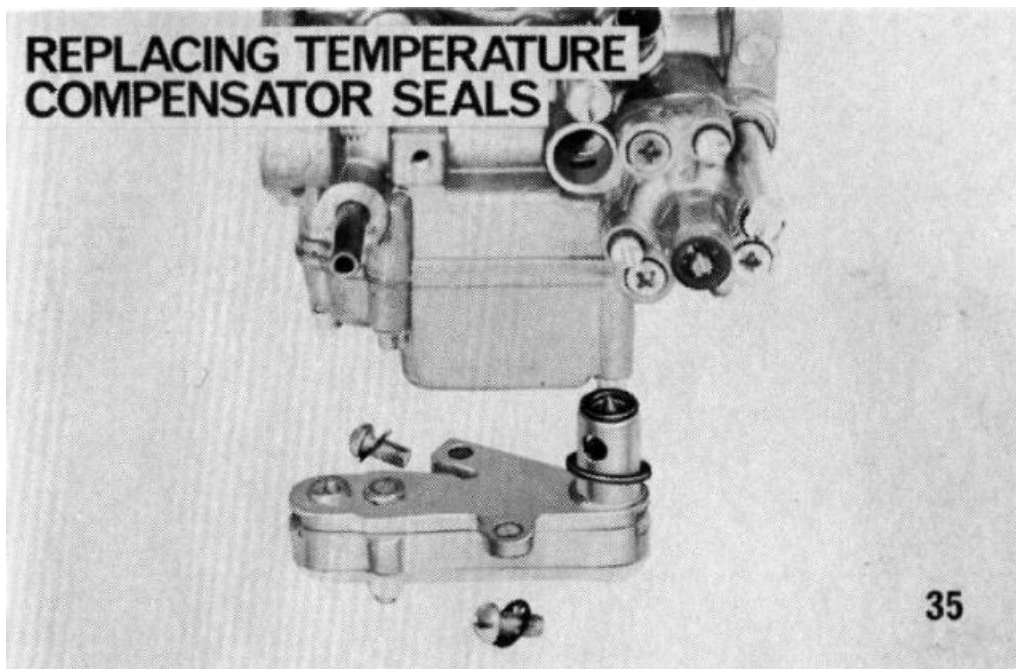

FRAME 35

Replacing Temperature Compensator Seals

1. Remove the temperature compensator assembly by slackening off the two retaining screws on either side of the compensator body.
2. Check valve operation for freedom of movement and correct seating.
NOTE: The adjustment nut on the bi-metal strip has been pre-set and attempts must not be made to alter it.

If a fault is suspected in the valve operation the assembly must be changed.

3. Replace the two seals.
4. Fit the assembly to the carburettor body and tighten the two retaining screws.

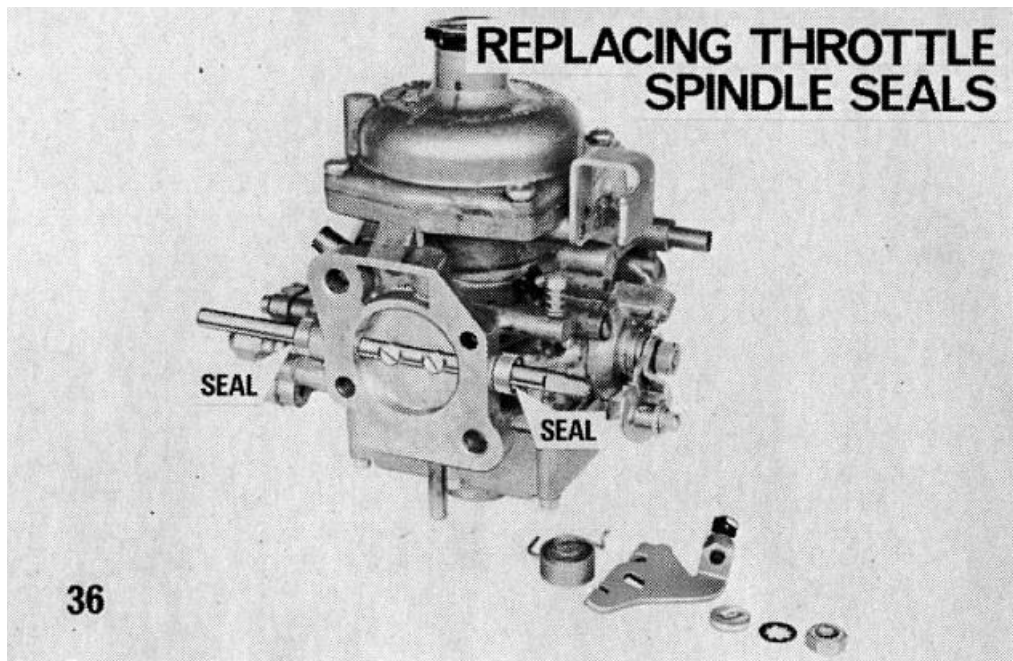

FRAME 36

Replacing Throttle Spindle Seals

Remove the throttle spindle lever assembly (right-hand picture).

Remove the throttle plate.

Remove the throttle spindle seals by prising out with a screwdriver.

Press new seals into position.

Assemble the throttle spindle lever assembly.

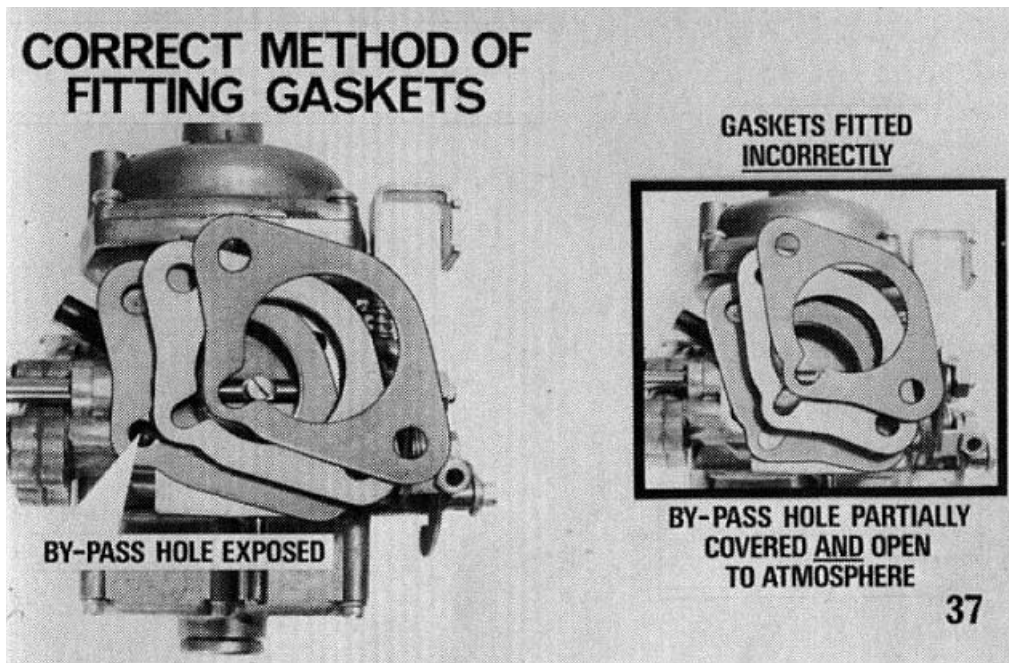

FRAME 37

Alignment of Gaskets to Carburettor Flange

There are three gaskets to each carburettor flange. The asbestos gasket is sandwiched between the two composite gaskets.

When fitting, ensure that the cut-away in the gasket lines up with the by-pass valve passage.

NOTE: Blanking off the by-pass passage will **SERIOUSLY UPSET THE EXHAUST EMISSION CONTROL.**

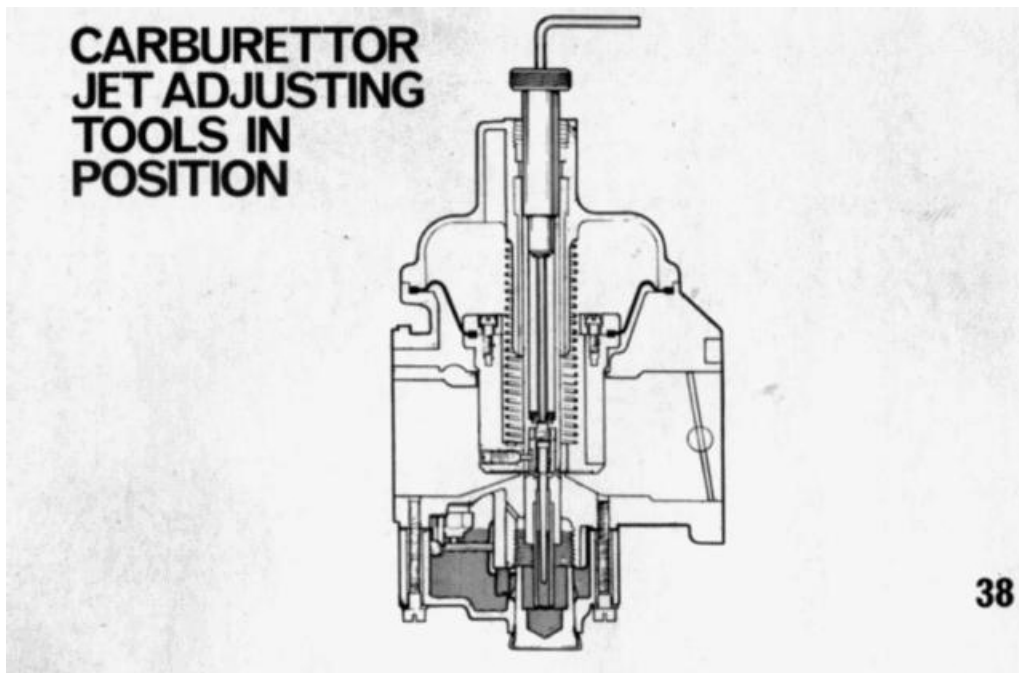

FRAME 38

Carburettor Needle Adjustment Through the Top Cover

Provision is made to adjust the air/fuel ratio by moving the carburettor needle, using the special tools shown above.

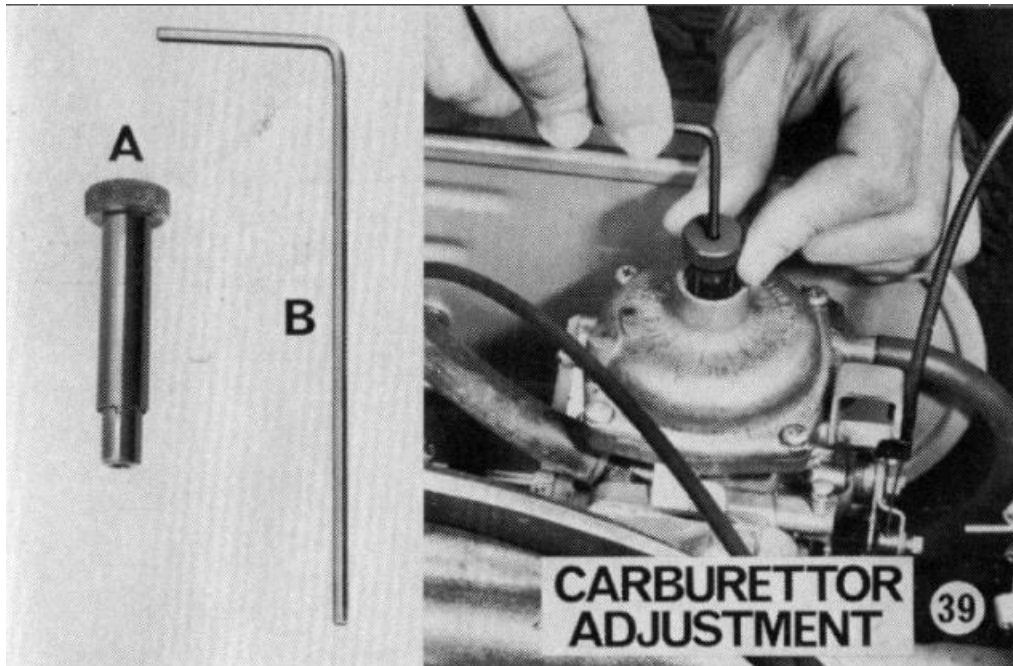

FRAME 39

Carburettor Needle Adjustment Through the Top Cover

Provision is made to adjust the air/fuel ratio within the permitted range by moving the carburettor needle using the special tools shown above.

IT IS ESSENTIAL THAT ADJUSTMENTS ARE MADE ONLY BY AUTHORIZED DEALERS OR DISTRIBUTORS USING APPROVED NON-DISPERSIVE INFRA-RED CO MEASURING EQUIPMENT, AND TO ENSURE THAT THE LEGAL CO LEVELS ARE NOT EXCEEDED.

NOTE:

The air cleaner MUST be in position when adjusting the carburettor mixture.

Before attempting to adjust the mixture, screw the trimming screw in against its seat.

To adjust the air/fuel mixture unscrew the damper from the carburettor top cover and to prevent loss of damper oil, slowly insert tool 'A' until the lugs engage with the slots in the air valve tube. Insert tool 'B' through the centre of 'A' which automatically centres the hexagonal end of tool 'B' to engage with the screw adjustment at the bottom of the air valve tube.

To richen the mixture hold tool 'A' to prevent the air valve turning and rotate tool 'B' in a clockwise direction by increments of one-quarter of a turn.

If the car is fitted with twin carburettors it is ESSENTIAL to adjust BOTH carburettors by the same amount.

To weaken the mixture turn tool 'B' in an anti-clockwise direction.

There is approximately one full turn in each direction.

It is very important to avoid prolonged idling when checking air/fuel ratios. After each three-minute continuous testing, run the engine at 2,000 rev/min for one minute.

Remove the special tools, check carburettor air valve damper oil level and replace the damper.

Further fine adjustments to the mixture, to aid drivability of the vehicle, may be made using the trimming screw as described in the next frame.



FRAME 40

Trimming Screw Adjustment

Having checked all settings, couple up on air/fuel ratio meter and observe combustion efficiency. If the readings are slightly outside the permitted limits, adjust both carburetter trim screws by equal amounts until the needle reads within limits.

NOTE: The trim screw is not an ordinary mixture adjusting screw. The adjustment is so fine that only with the use of a meter can the results be detected.

It is very important to avoid prolonged idling when checking the air/fuel ratios. After each three-minute continuous testing, run the engine at 2,000 rev/min for one minute.

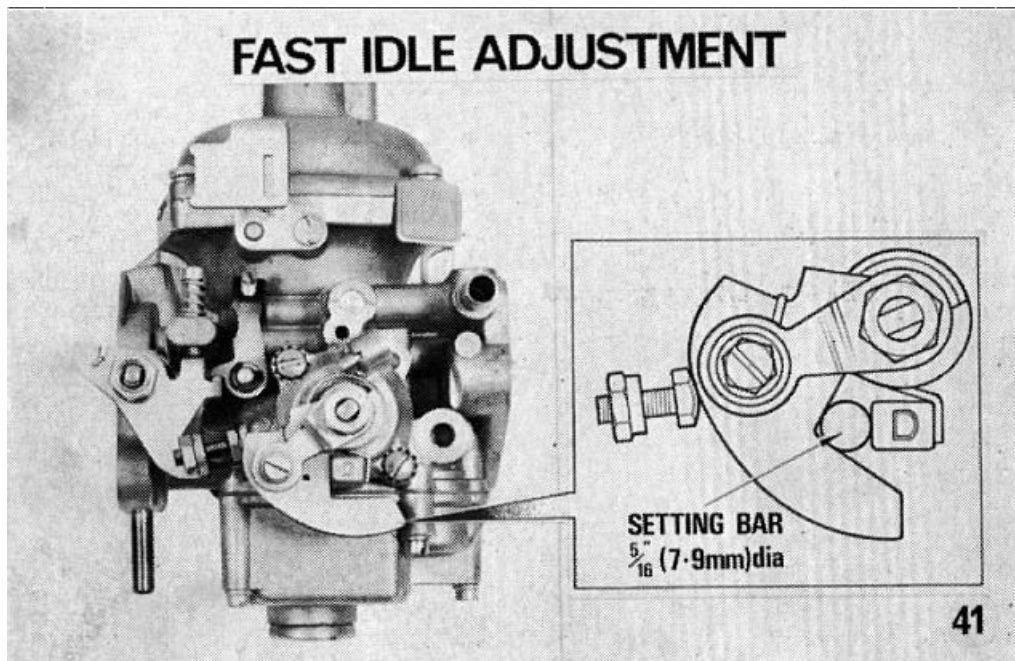

FRAME 41

Carburettor Linkage

A certain amount of 'lost motion' is incorporated in the carburettor linkage on all models to the fast idle condition without disturbing the closed position of the throttle. The amount of lost motion is not adjustable and must not be confused with wear.

Fast Idling

The engine should be tuned so that the idling speed is between 800 and 850 rev/min.

Stop the engine and place a piece of $\frac{5}{16}$ in (7.9 mm) diameter bar between the fast idle cam and the stop as shown in the illustration.

Adjust the fast idle screw until the head of the screw just touches the cam, then tighten the locknut and remove the setting bar.

The above setting should give a fast idle of 1,300 rev/min engine HOT and approximately 1,100 rev/min engine COLD.

NOTE: If the engine is fitted with twin carburettors the above setting must be carried out on each carburettor except the Triumph Stag.

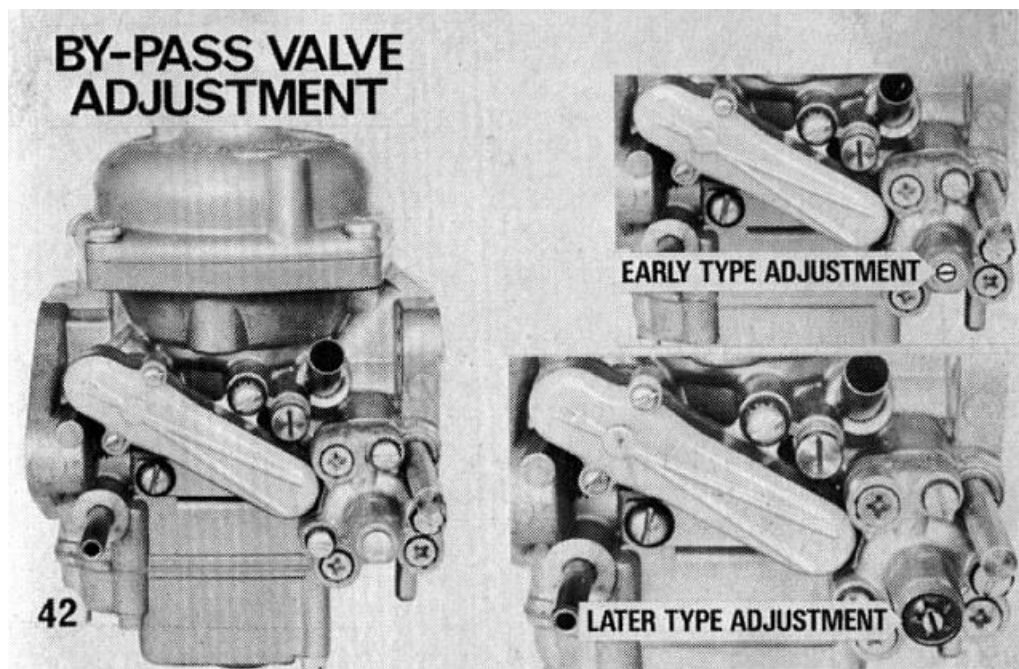

FRAME 42

By-Pass Valve Adjustment

If complaints are received of lack of engine braking or very high idling speeds and the engine is found to be in a good state of tune, the by-pass valve may be floating on its seating.

To check for this condition, remove the distributor vacuum pipe from the manifold and place a finger over the hole in the manifold.

If the by-pass valve is floating, then the above procedure will aggravate the condition, causing a sudden increase in engine speed which is maintained.

With the valve operating correctly, with the vacuum pipe removed, the engine idle speed should rise to approximately 1,300 rev/min.

NOTE: If the valves are removed for cleaning, they should be refitted and adjusted according to the procedure given [below].

Adjustment

Early cars with 1973 specification have a by-pass valve adjustment screw, which is covered by a washer shown in the illustration 'A'.

NOTE: The washer must be replaced when any adjustment has been made. On later cars the adjustment screw is exposed as in 'B'.

NOTE: It is not necessary to remove the spring clip when turning the adjustment screw.

If the engine is fitted with two carburetters the by-pass valve adjustment screw on the carburetter NOT being adjusted should be screwed anti-clockwise fully onto its seat.

This procedure prevents the one by-pass valve from working while the valve on the other carburetter is adjusted. It is not necessary to repeat this procedure when re-adjusting the other by-pass valve on the second carburetter.

Remove the distributor vacuum pipe from the manifold and block off the hole in the manifold. Screw the by-pass valve clockwise until engine speed increases abruptly (approximately 2,000 to 2,500 rev/min), the valve is then 'floating' on its seat. Turn the adjustment screw anti-clockwise until the engine **just** returns to normal idle.

Using the throttle, suddenly increase engine speed and return to normal: engine speed should drop to approximately 1,300 rev/min. If not, the valve is still 'floating': re-adjust valve as necessary.

When the necessary condition has been achieved, turn the by-pass valve adjustment screw ANTI-CLOCKWISE half a turn to seat the valve correctly. Replace the washer in the body of the deceleration valve if necessary.

Repeat the operation on the remaining carburetter. When the by-pass valves on both carburetters are correctly set, unplug the manifold vacuum hole and refit the distributor vacuum pipe.

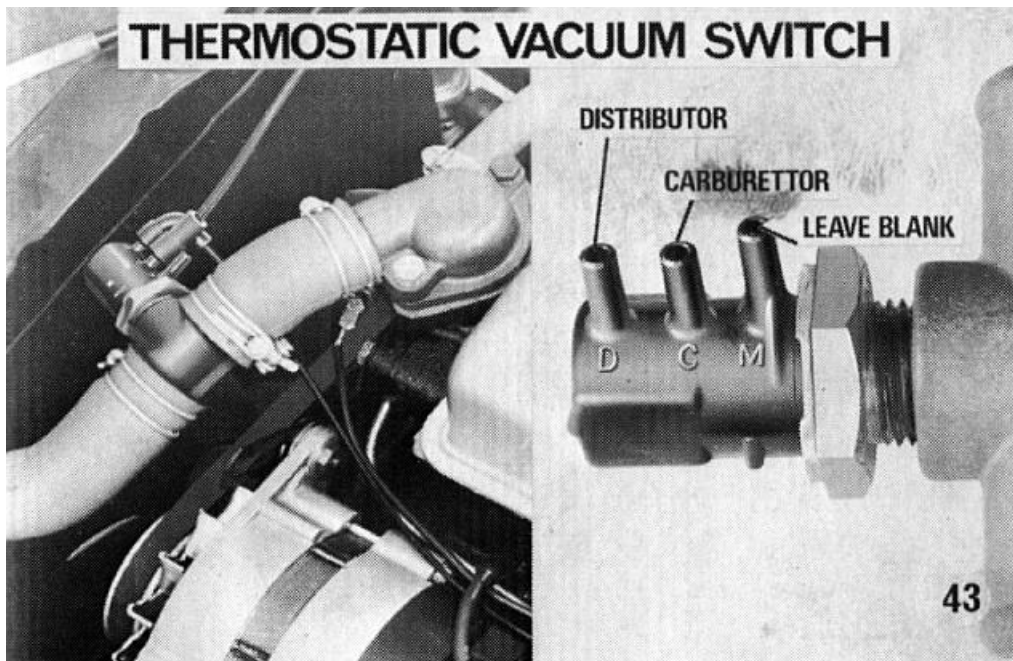

FRAME 43

Thermostatic Vacuum Switch

Thermostatic vacuum switches are fitted to all U.S.A. cars, an example of which is shown in the illustration.

The switch is integral with the cooling system and vacuum pipes from the carburettor and distributor are fitted to the switch.

During high ambient temperatures and city driving the coolant temperature may become excessive, in which case a valve is actuated in the switch, by the thermostat, which then closes off the vacuum retard to the distributor.

This action allows the engine speed to rise, allowing greater coolant circulation and thereby reducing overheating.

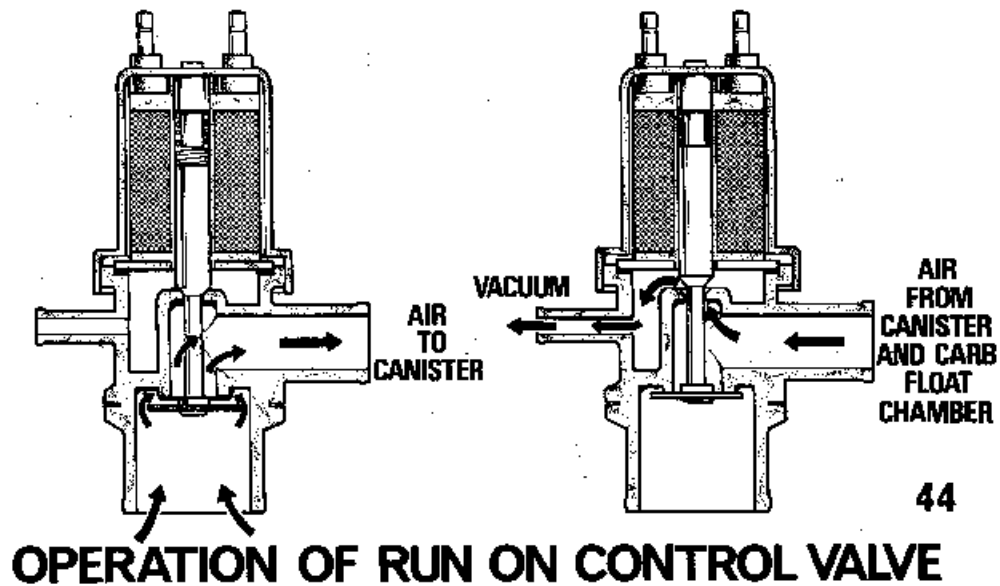

FRAME 44

'Run-On' Control Valve

Due to the rigorous U.S.A. Federal Laws governing the exhaust emission and the use of specified fuels, current production engines have a tendency to 'run-on' after the ignition is switched off.

To combat this condition a run-on control valve is fitted to the bottom of the charcoal canister and actuated through the ignition switch.

Description

A solenoid moves a valve which seals off the air inlet to the bottom of the charcoal canister.

At the same time a passage is opened in the valve body to allow manifold vacuum to act through the canister, vent valve hose and drilling to the carburettor, causing a depression in the float-chamber.

The vacuum created equals the vacuum in the constant depression area of the carburettor, thus preventing fuel from rising and entering the air orifice and therefore stopping the engine.

As the oil pressure drops, an oil pressure sensitive switch breaks the electrical circuit and de-energizes the solenoid. The engine is then ready again for operation.

DIAGRAMMATIC LAYOUT OF RUN-ON CONTROL VALVE SYSTEM

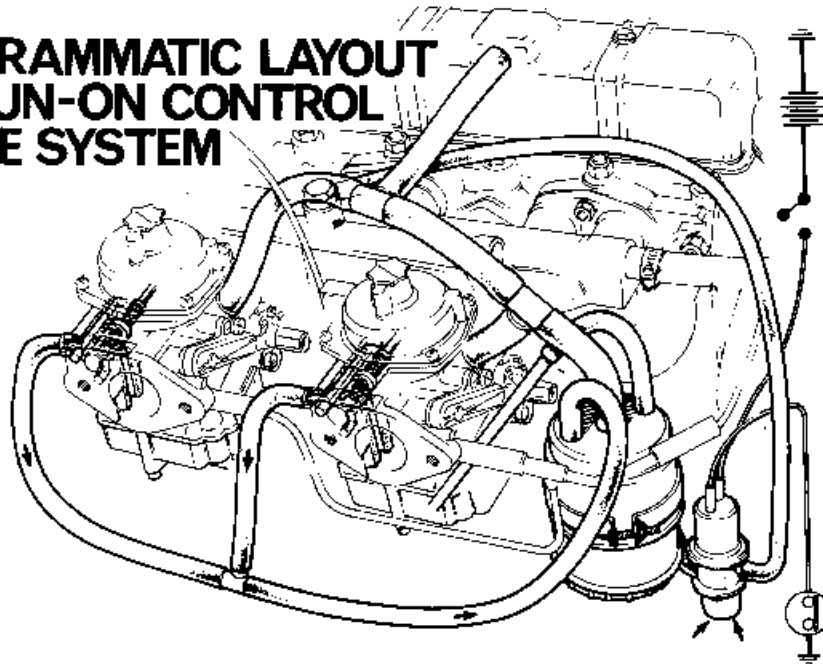

45

FRAME 45

System Checks

If the run-on control valve fails to operate, this will be apparent by engine continuing to 'run-on'. Check that the vent valves on both carburetors are correctly set: refer to [page 29](#). If the valves are not set correctly, air will bleed into the float-chamber preventing a vacuum, although the run-on control is actuated, and so allowing the engine to continue to run-on.

A system check can be made by applying current to the solenoid which, if working correctly, will stop the engine. The engine should stop if the valve is lifted manually.

Ensure that the oil pressure switch fitted to the side of the cylinder block is wired correctly; see [page 54](#).

Check that the restrictor on the top of the canister is in position, otherwise the run-on valve does not operate correctly and this will also cause a lumpy idle condition.

The system does not require servicing, apart from periodically checking the hoses for deterioration.



FRAME 46

Engine Run-On Control, Oil Pressure Switch

It is essential that the electrical connections on the oil pressure switch, which is screwed into the main oil gallery on the side of the engine block, are correctly fitted.

The electrical connections should be fitted as shown in the illustration, otherwise the solenoid will not operate.

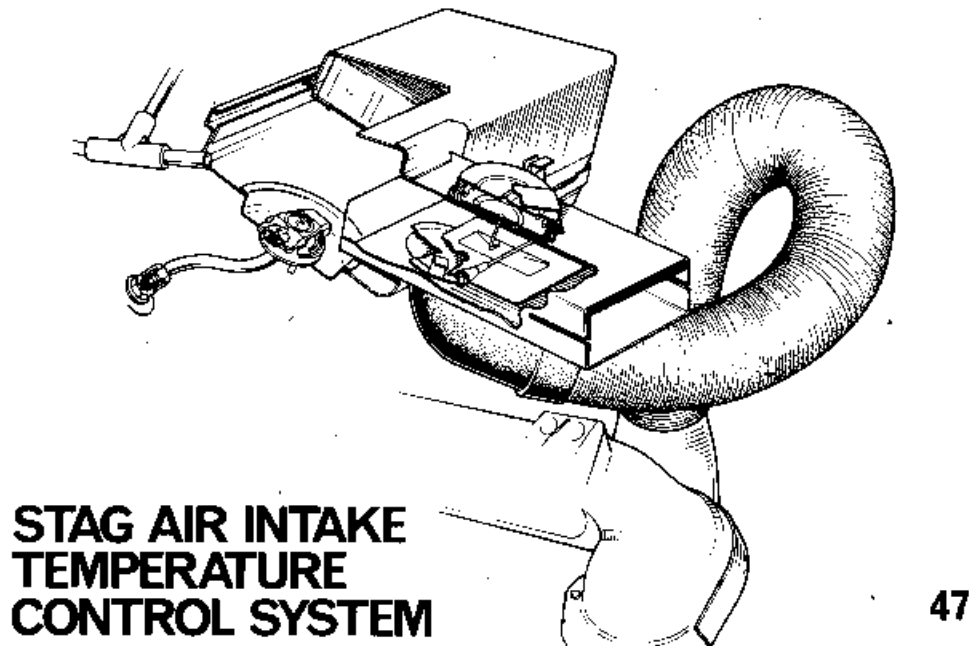

FRAME 47

Part 6

Air Intake Temperature Control System

The carburetors on the Triumph Stag are designed to work efficiently when the air intake temperature is above 105 deg. F (40.6 deg. C).

To maintain this efficiency, a temperature sensing device is incorporated in the air cleaner.

From a cold start, the temperature sensor allows inlet manifold vacuum to operate a flap valve in the air cleaner intake.

The flap valve controls the mixing of cold air, from forward of the radiator, and hot air which is drawn over the exhaust manifold via a duct, to the air cleaner.

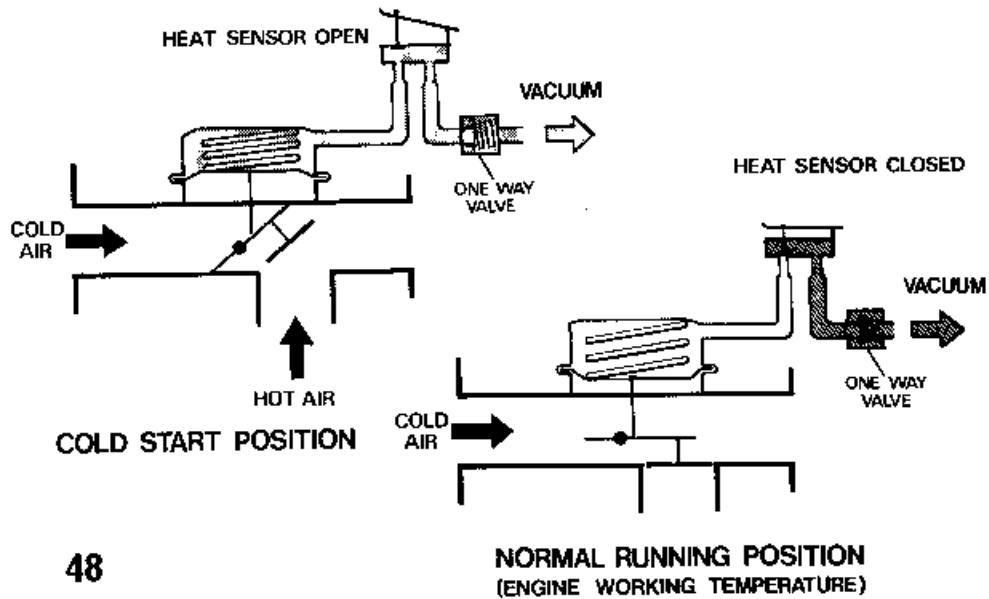

FRAME 48

As the engine warms up to normal operating temperature, the sensing device gradually allows the flap valve to accept more air at ambient temperature to provide the correct intake temperature.

To avoid stalling the engine when cold, during sudden increases of engine speed, a one-way valve is fitted to the inlet manifold.

The one-way valve provides a delay factor, which prevents the flap valve suddenly moving to the fully open position due to manifold depression being temporarily destroyed and allowing a rush of cold air to the carburetters.



FRAME 49

If the action of the air intake control system is suspect through poor cold engine running characteristics, the components may be checked individually as described in the above and succeeding three frames.

NOTE: Before carrying out checks, ensure all pipes are in good condition and are making good connection on their respective components.

Checking the Flap Motor

Couple the flap motor to a vacuum pump as shown in the illustration and apply a minimum vacuum of 9 inHg (30.3 kN/m²). Check that the flap has moved to the fully closed, hot position. Release the vacuum and ensure that the flap has returned to the fully open, cold position.

If the flap motor has failed the above test, the flap motor and air cleaner cover must be renewed.



FRAME 50

Checking the One-Way Valve

Couple up the one-way valve to the vacuum pump as shown.

Apply a minimum vacuum of 9 inHg (30.3 kN/m²) and check for correct operation of flap (i.e. 'hot' position) closed.

Stop the vacuum pump.

If the one-way valve is working correctly, the time taken for the flap valve to operate from the fully closed hot air position to the fully open cold air position should be a minimum of 20 seconds.

If the time taken for the operation is less than that stated, the valve should be changed.



FRAME 51

Checking the Operation of the Temperature Sensor Unit

Couple the flap motor and sensor unit to a vacuum pump as shown. Apply a minimum vacuum of 9 inHg (30.3 kN/m²) and check that the flap motor has moved to the closed, hot position..

If the flap gradually opens although the vacuum is sustained, the sensor unit may be leaking as described in the next frame.



FRAME 52

Checking the Temperature Sensor Unit

Place the sensor unit in a glass jar as shown.

NOTE: Seal off one of the outlet tubes. Blow down the tube and watch for a stream of bubbles which will denote a leak.

Air leaking from the periphery of the unit may be sealed using [Araldite](#) or a similar preparation sparingly.

CAUTION: Ensure that the sealing compound does not come into contact with the sensor valve itself.

Fault Finding- Air Intake Temperature Control

SYMPTOM	CAUSE	ACTION
	Vacuum pipes disconnected or leaking	Re-connect or renew pipes
	Temperature sensor leaking	Renew sensor
Poor 'cold engine' running characteristics	Flap valve diaphragm leaking	Renew motor and cover
	Flap valve stuck in cold air mode	Renew motor and cover
	Hot air hose disconnected or [sic]	Reconnect or renew hose
	Sensor operating below required temperature	Renew sensor
Flat spot or hesitation on acceleration	One-way valve leaking	Renew valve
Engine overheating	Flap valve stuck in hot air position	Renew motor and cover
	Sensor valve stuck or operating higher than required temperature	Renew sensor

Part 7

Fault Finding- Emission Carburetter

NOTE: Before undertaking extensive carburetter servicing it is recommended that other engine factors and components such as cylinder compressions, valve clearance, distributor, sparking plugs, air intake temperature control system, etc., are checked for correctness of operation.

SYMPTOM	CAUSE	ACTION
1. Poor idle quality	a. Air leakage on induction manifold joints	Re-make joints as necessary. Check idle carbon monoxide level with CO meter
	b. Throttles not synchronized	Re-balance carburetters and reset linkage
	c. Air valve or valves sticking in piston guide rods	Clean air valve rods and guides and reassemble. Check piston free movement by hand; unit should move freely and return carburetter bridge with an audible click.
	d. Partially or fully obstructed float-chamber or diaphragm ventilation holes	Check that gasket(s) are not causing obstruction or piping obstructed
	e. Incorrect fuel level caused by maladjusted float assemblies or worn or dirty needle valve	Reset float heights and clean or replace needle valves worn [sic]
	f. Metering needle incorrectly fitted or wrong type of needle fitted	Ensure shoulder of needle is flush with face of air valve and that needle bias is correct
	g. Diaphragm incorrectly located or damaged	Check location with air valve cover removed, piston depression holes should be in line with and face towards the throttle spindle. Renew diaphragm with correct type if damage is in evidence
	h. Leakage from retard pipe connections	Re-make connections and re-check ignition settings
	i. Temperature compensator faulty	With engine and carburetter cold, check that compensator cone is seated and free to move off seat. If any doubt exists, replace unit with new assembly
	j. After considerable service leakage may occur at throttle spindle or secondary throttle spindles	Replace spindle seals or spindles as required

SYMPTOM	CAUSE	ACTION
2. Hesitation or 'flat spot': a, b, c, d, e, f, g and h plus	Piston damper inoperative	Check damper oil level and top up with specified oil: recheck damper operation by raising piston by hand, whereupon resistance should be felt
	Air valve spring missing or wrong part fitted	Check correct grade of spring and refit as required
	Ignition timing incorrect	Check and reset as required
	Throttle linkage operation incorrect	Check operation of linkage between carburetters and operation of secondary throttle links: reset or replace as required
3. Heavy fuel consumption: 1 and 2 plus	Leakage from the fuel connections, float-chamber joints or sealing plug 'O' rings	Replace gaskets and 'O' ring as required
	Faulty by-pass valve	Replace by-pass valve with new unit
4. Lack of engine braking	Sticking throttles	Check throttle operation and reset as required
	Ignition retard inoperative	Check ignition setting at idle and ensure correct functioning of retard system
5. Lack of engine power	Damaged diaphragm	Inspect and replace if incorrectly fitted or damaged
	Low fuel flow	Check discharge from fuel pump. Inspect needle valve seating

NOTE: To ensure compliance with exhaust emission legislative requirements, the following items **MUST NOT** be changed or modified in any way:

The fuel jet assembly; the air valve; the depression cover; the position of the fuel metering needle.

The following items must not be adjusted in service but should be replaced completely by factory-set units:

The temperature compensator; the air valve return spring; the by-pass unit; the starter assembly.

1. Poor/rough idle
2. Loss of power/poor drive-away
3. Misfiring (under load conditions)
4. High fuel consumption
5. High idling speed
6. Overheating (at idle speed)
7. Lean running
8. Arcing at plugs
9. Smell of fuel
10. Rich mixture
11. Stalling
12. Engine run-on

SYMPTOM												CAUSE	ACTION
1	2	3	4	5	6	7	8	9	10	11	12		
X	X	X										Distributor contact breaker points	Check dwell angle/check gap and reset/renew points
X	X	X										Sparking plugs	Check gap and reset/renew defective plug
X	X	X					X					Ignition wiring	Inspect for fraying, chafing and deterioration/renew
X	X		X									Choke mechanism	Check fast idle adjustment/cam and cable/adjust
X	X		X									Choke mechanism	Remove starter box and clean interface
X	X			X						X		Vacuum fittings, hoses and connections	Check piping condition and security/renew as necessary
X	X					X						Oil filler cap	Check for security/tighten cap
X	X					X						Ventilation hoses	Check hoses for security, blockage and deterioration
X			X									Carburetter	See carburetter fault finding chart
	X											Distributor	Lubricate/check operation by removing pipe and noting rev/min
	X		X									Carburetter air cleaner	Clean or renew element
	X			X	X							Ignition timing and advance systems	Check and reset dynamic timing
			(X)									Condenser and coil	Check for breakdown on oscilloscope tune
			X					X				Hose connections	Check for hose damage and deterioration
									X			Carbon storage canister	Renew canister(s)
					(X)							Vacuum advance switch	Check switch operation, and renew if necessary
										X		Run-on valve	Check valve operation, and renew if necessary