

TOOLBOX ROBOTICS

Collaborative Robotic Arm EB300

Electrical Guidebook

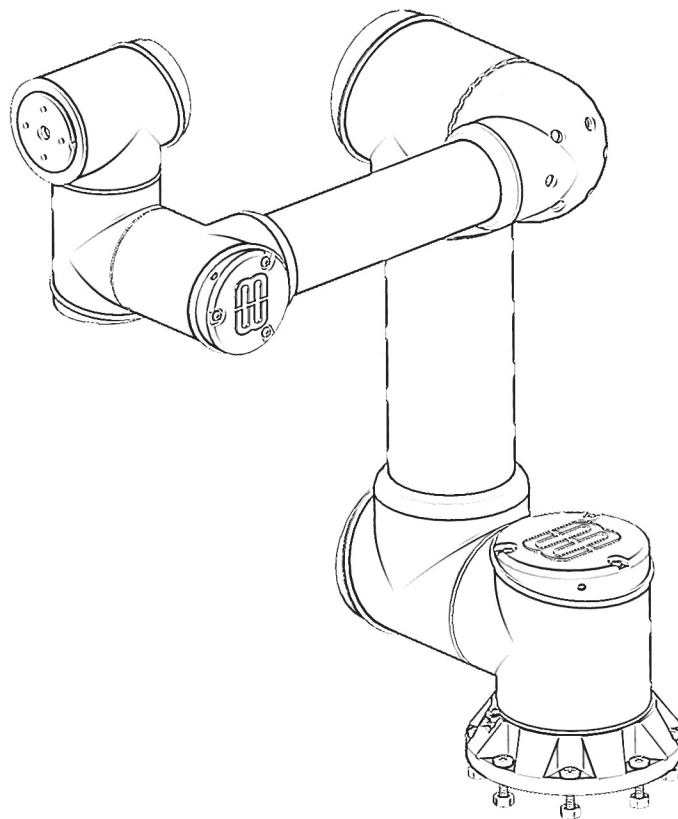

Table of Contents

Preface

| | |
|---|----|
| Safety Statement _____ | 3 |
| Tools _____ | 4 |
| Project Cost _____ | 5 |
| Materials _____ | |
| ▪ NEMA Stepper Motors | 6 |
| ▪ Stepper Motor Driver | 7 |
| ▪ Power Supply Unit | 8 |
| ▪ Microcontroller | 9 |
| ▪ Wire & Cable | 10 |
| ▪ Plug & Connector | 11 |
| ▪ Plug & Connector | 12 |
| ▪ Plug & Connector | 13 |
| ▪ Plug & Connector | 14 |
| Planetary Gears Actuators _____ | 15 |
| Power Setting & Wiring _____ | 16 |
| Microcontroller Setting & Wiring _____ | |
| ▪ 1 Servomotor | 17 |
| ▪ 8 Servomotors | 18 |
| ▪ Inputs | 19 |
| ▪ Outputs | 20 |
| ▪ Drivers | 21 |
| Motor Setting & Wiring _____ | |
| ▪ Base (J1) | 22 |
| ▪ Shoulder (J2) | 23 |
| ▪ Elbow (J3) | 24 |
| ▪ Wrist 1 (J4) | 25 |
| ▪ Wrist 2 (J5) | 26 |
| ▪ Wrist 3 (J6) | 27 |

Safety Statement

Safety Statement

The author of this document is not liable or responsible for any accidents, injuries, equipment damage, property damage, loss of money or loss of time resulting from improper use of electrical or mechanical or software products.

Assembling electrical machine components like power supplies, motors, drivers or other electrical components involves dealing with high voltage AC (alternating current) or DC (direct current) which can be extremely dangerous and needs high attention to detail, experience, knowledge of software, electricity and electro-mechanics or mechanics.

BEFORE MAKING ANY CONNECTIONS OR DISCONNECTIONS POWER MUST BE REMOVED FROM THE DEVICE AND THE CONTROLLER.

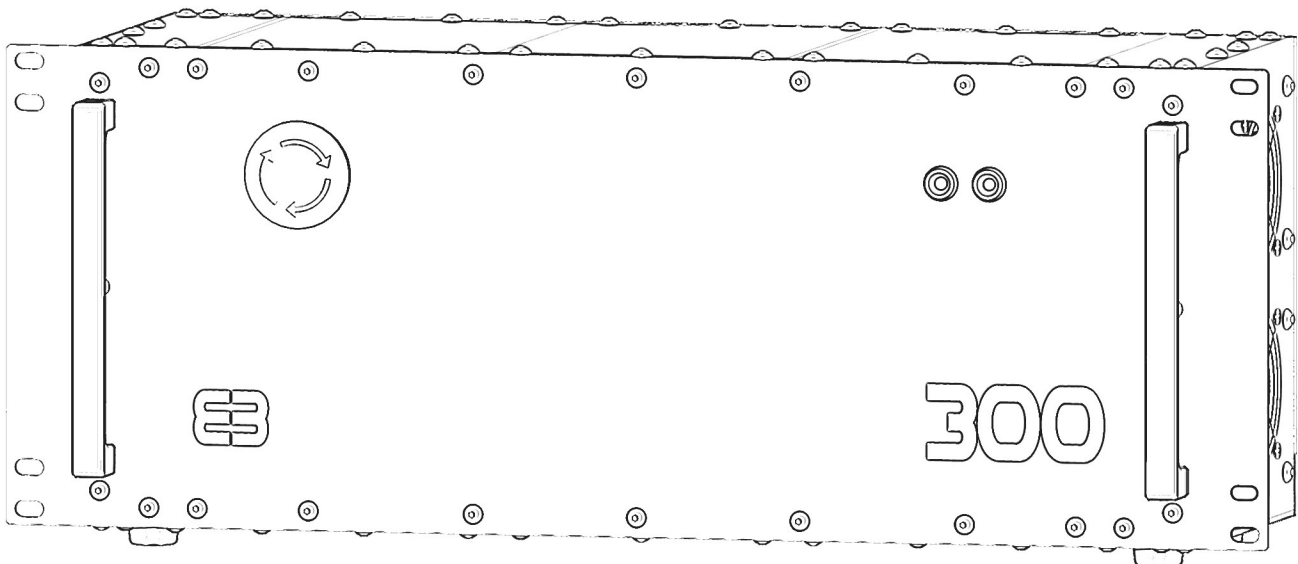

Note: Products with electrical plugs are designed for use in the US and North America. Outlets and voltage differ internationally and this product may require an adapter or converter for use in your destination. Please check compatibility before purchasing.

Tools

Necessary tools

Soldering Iron Kit



Third Hand Clamp Helping



Electrical Tape White & Sharpie



Project Cost

Approximate cost of the project

For the Robotic Arm

| | | | |
|-----------------------------|-------------|----|-------------|
| ▪ Stepper Motor NEMA17 60mm | USD \$15.00 | x3 | USD \$45.00 |
| ▪ Stepper Motor NEMA23 76mm | USD \$25.00 | x1 | USD \$25.00 |
| ▪ Stepper Motor NEMA23 82mm | USD \$30.00 | x2 | USD \$60.00 |

For the Control Unit

| | | | |
|---|-------------|----|-------------|
| ▪ Microcontroller Arduino MEGA 2560 | USD \$20.00 | x1 | USD \$20.00 |
| ▪ Motor Driver TB6600 | USD \$10.00 | x6 | USD \$60.00 |
| ▪ Universal Power Supply DC 24V 15A 360W | USD \$22.00 | x1 | USD \$22.00 |
| ▪ Emergency Stop Push Button Red Mushroom | USD \$10.00 | x1 | USD \$10.00 |
| ▪ Power Plug Socket AC 10A Male 3 Pins | USD \$5.00 | x1 | USD \$5.00 |
| ▪ Power Plug Cord AC Female 3 Pins | USD \$5.00 | x1 | USD \$5.00 |
| ▪ 18/4 AWG Wire Cable 30 FT | USD \$25.00 | x1 | USD \$25.00 |
| ▪ 22 AWG Solid Core Wire Kit 6 colors | USD \$25.00 | x1 | USD \$25.00 |
| ▪ DC-DC Buck Step Down LM2596 | USD \$3.00 | x2 | USD \$6.00 |
| ▪ 8 Channel DC 5V Relay Module | USD \$10.00 | x1 | USD \$10.00 |
| ▪ Dupont Connector Kit | USD \$15.00 | x1 | USD \$15.00 |
| ▪ Heat Shrink Tube Kit | USD \$10.00 | x1 | USD \$10.00 |

Advanced options:

| | | | |
|--|-------------|----|-------------|
| ▪ Switchs | USD \$1.00 | x8 | USD \$8.00 |
| ▪ 8 Channel DC Relay Module | USD \$10.00 | x1 | USD \$10.00 |
| ▪ Servo Motor MG995 | USD \$10.00 | x1 | USD \$10.00 |
| ▪ DC-DC Buck Step Down 20A 300W | USD \$10.00 | x1 | USD \$10.00 |
| ▪ Brushless Cooling Fan 60mm x 15mm DC 24V | USD \$7.00 | x2 | USD \$14.00 |

Price source: amazon.com

Materials - NEMA Stepper Motors

NEMA 17 stepper motor 60mm

NEMA 17 is a hybrid stepping motor with a 1.8° step angle (200 steps/revolution).

Specification:

- 4 wires or 6 wires
- 1.8 deg. Step angle (200 steps/rev)
- Holding torque of 0.65 Nm
- Rated current 2.1 A
- Dimensions: 42 x 42 x **60mm**
- Rod diameter: $\Phi 5$ mm

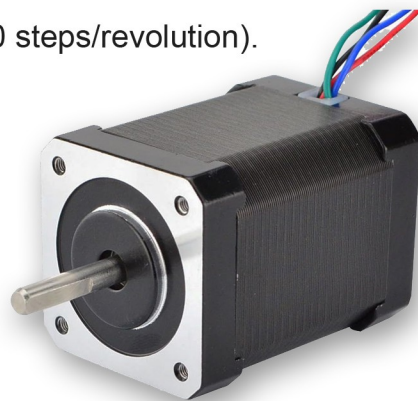

NEMA 23 stepper motor 76mm

NEMA 23 is a hybrid stepping motor with a 1.8° step angle (200 steps/revolution).

Specification:

- 4 wires or 6 wires
- 1.8 deg. Step angle (200 steps/rev)
- Holding torque of 1.85 Nm
- Rated current: 2.8 A
- Dimensions: 57 x 57 x **76mm**
- Rod diameter: $\Phi 8$ mm or $\Phi 6.35$ mm

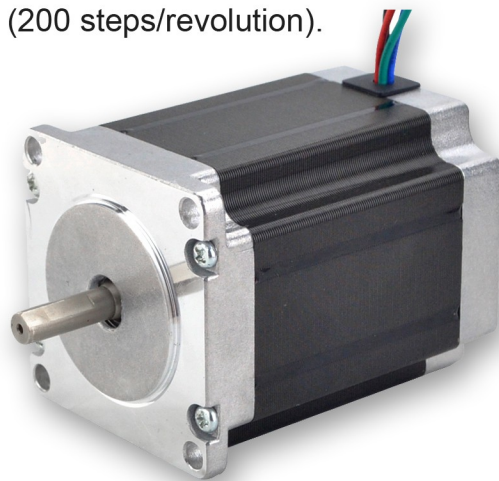

NEMA 23 stepper motor 82mm

NEMA 23 is a hybrid stepping motor with a 1.8° step angle (200 steps/revolution).

Specification:

- 4 wires or 6 wires
- 1.8 deg. Step angle (200 steps/rev)
- Holding torque of 2.4 Nm
- Rated current: 4.0 A
- Dimensions: 57 x 57 x **82mm**
- Rod diameter: $\Phi 8$ mm or $\Phi 6.35$ mm

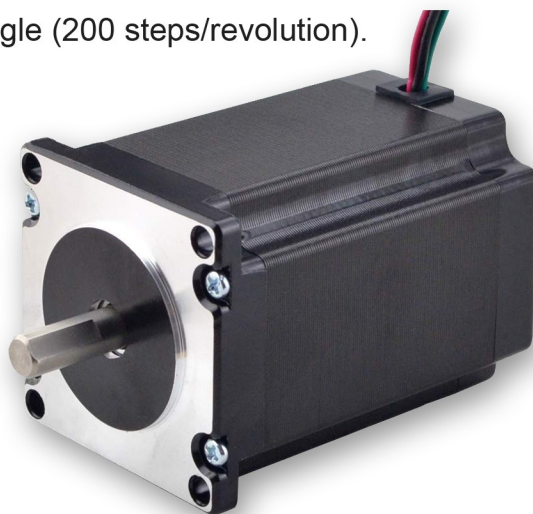

Materials - Stepper Motor Driver

Stepper Motor Driver

The TB6600 single axis drive is a low cost microstepping drive. It is suitable for driving 2-phase and 4-phase hybrid stepper motors.

Signal Input:

- EN- Off-line Control Enable - **(Enable signal)**
- EN+ Off-line Control Enable + **(Enable signal)**
- DIR- Direction - **(Direction signal)**
- DIR+ Direction + **(Direction signal)**
- PUL- Pulse - **(Step pulse signal)**
- PUL+ Pulse + **(Step pulse signal)**

Motor Machine Winding:

- B- Stepper Motor B-
- B+ Stepper Motor B+
- A- Stepper Motor A-
- A+ Stepper Motor A+

Power Supply:

- GND GND
- VCC VCC (DC 9~42V)

DIP Switch Settings



Micro-Step Setting

| Micro Step | Pulse/Rev | 1 | 2 | 3 |
|------------|-----------|-----|-----|-----|
| NC | NC | ON | ON | ON |
| 1 | 200 | ON | ON | OFF |
| 2/A | 400 | ON | OFF | ON |
| 2/B | 400 | OFF | ON | ON |
| 4 | 800 | ON | OFF | OFF |
| 8 | 1600 | OFF | ON | OFF |
| 16 | 3200 | OFF | OFF | ON |
| 32 | 6400 | OFF | OFF | OFF |

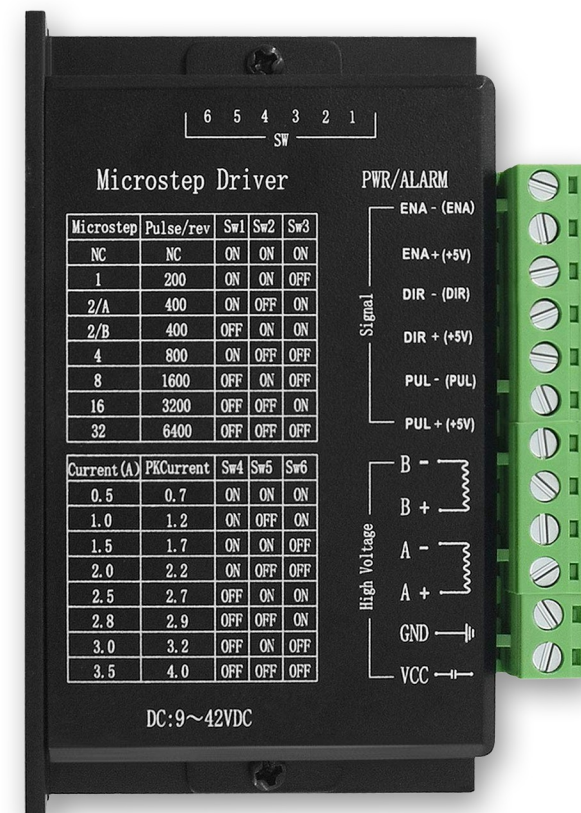

Current Control Setting

| Current (A) | 4 | 5 | 6 |
|-------------|-----|-----|-----|
| 0.5 | ON | ON | ON |
| 1.0 | ON | OFF | ON |
| 1.5 | ON | ON | OFF |
| 2.0 | ON | OFF | OFF |
| 2.5 | OFF | ON | ON |
| 2.8 | OFF | OFF | ON |
| 3.0 | OFF | ON | OFF |
| 3.5 | OFF | OFF | OFF |

Materials - Power

Universal Power Supply 24V15A

24V 15A DC Universal Regulated Switching Power Supply 360W

Specification:

- Output current 0~15.0A
- Output voltage 24V DC
- Input voltage 110V or 220V AC
- You can choose the input voltage (110V/220V) by switch.
- Overload Protection, Over Voltage Protection



Electrical Wiring:

- L AC Line, single phase (Black)
- N AC Neutral (White)
- G AC Ground, protective earth (Green)
- V- DC -
- V+ DC +

Switch On/Off Power Socket Module Plug

Specification:

- Current 15A
- Voltage 125V AC
- Switch On/Off 10A
- 10A Fuse

Electrical Wiring:

- L AC Line, single phase (Red)
- N AC Neutral (Black)
- G AC Ground, protective earth (Yellow)

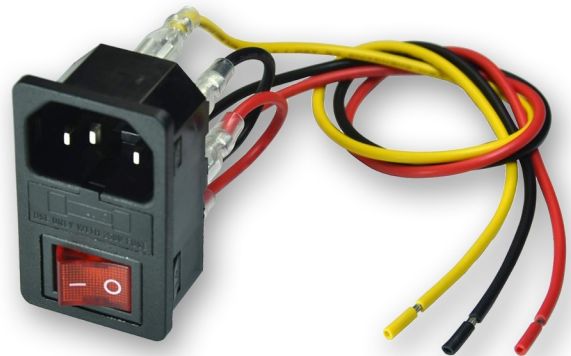

Universal AC Power Cable Cord

Specification:

- Current 15A
- Voltage 300V AC



Note: Plugs and voltage differ by country and this product may require an adapter or converter for use in your destination. Please check compatibility before purchasing.

Microcontroller Arduino MEGA 2560

Specification:

-

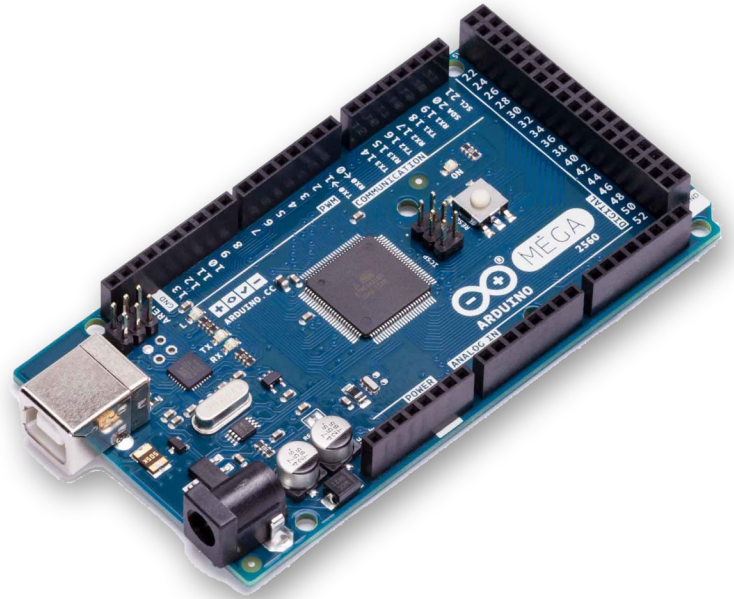

Materials - Wire & Cable

Wire

Specification:

- 18 AWG Electrical Wire
- Wire 4 Conductor,



Solid Core Wire Kit

Specification:

- 22 AWG Electrical Wire
- 6 Colors (Black, Red, Yellow, Green, Blue, White)



Wire Conduit Flexible

Specification:

- Wire Conduit Flexible 1/4in(6mm)
- Wire Conduit Flexible 3/8in(9mm)
- Wire Conduit Flexible 1/2in(12mm)
- Wire Conduit Flexible 1in(25mm)



Materials - Plug & Connector

Heat Shrink Tube Kit

Specification:

- 5 colors/12 Sizes, (Black, Red, Blue, Yellow, Green)



Dupont Connector Kit

Specification:

-

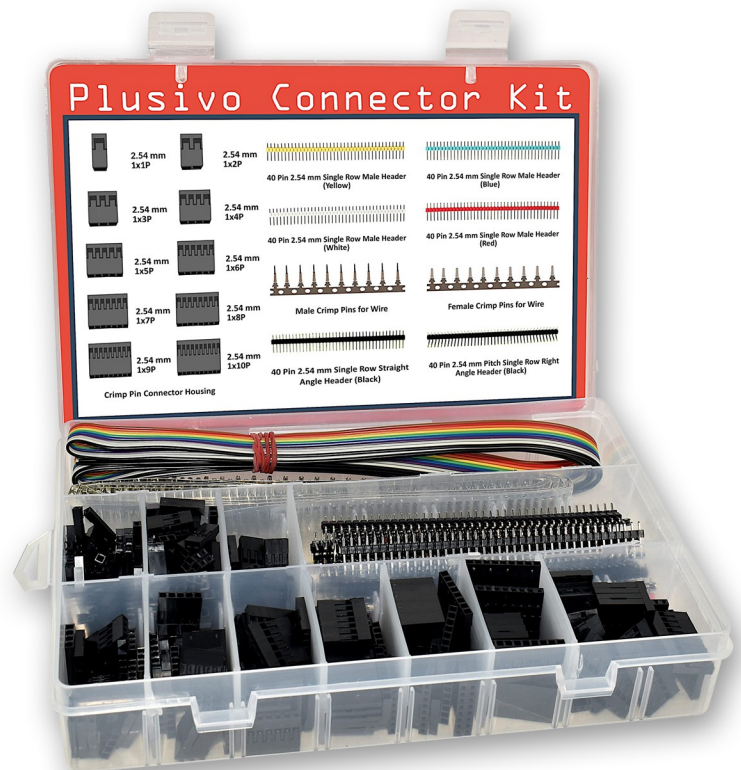

Materials

Brushless Cooling Fan

Specification:

- Dimensions: 60mm x 60mm x 15mm
- Rated Voltage: 24V DC, Current: 0.10A
- 2-Pin



Emergency Stop Push Button Red Mushroom

Specification:

- Rated Voltage: 24V DC, Current: 0.10A
- 2-Pin



Materials

DC-DC Step Down Variable Volt Regulator

Specification:

- DC-DC LM2596 power Supply
- Output Current: Rated Current 2A, Maximum 3A
- Input Voltage: DC 3.2~40V
- Output Voltage: DC 1.25~35V



DC-DC Step Down Variable Volt Regulator

Specification:

- Adjustable Step Down Voltage Regulator
- DC-DC Buck Converter Module
- Output Current: Rated Current 20A, 300W
- Input Voltage: DC 6~40V
- Output Voltage: DC 1.25~36V

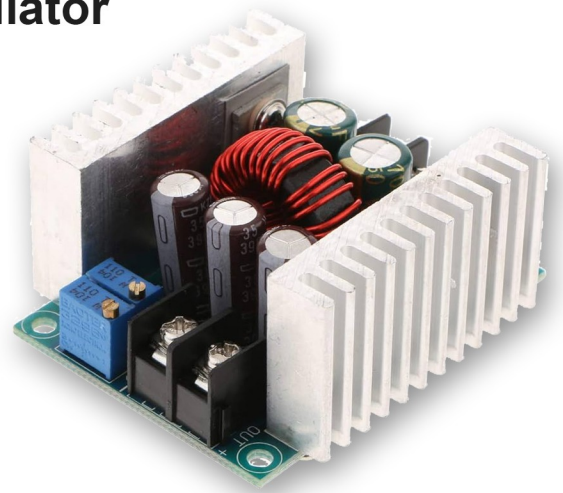

Materials

Switches

Specification:

-



Micro



Precision Limit Switch

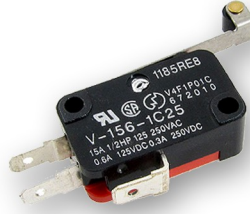

Simple Limit Switch

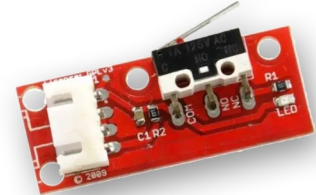

Limit Switch Module

Relay Modules

Specification:

- 1 Channel DC 5/9/12/24V Relay Module
- 2 Channels DC 5/9/12/24V Relay Module
- 4 Channels DC 5/9/12/24V Relay Module
- 8 Channels DC 5/9/12/24V Relay Module

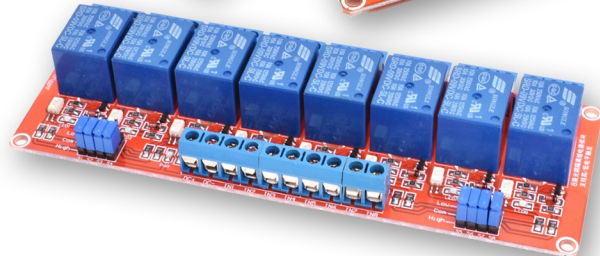
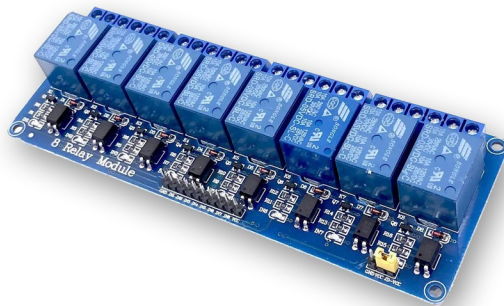
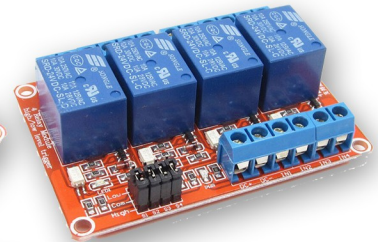
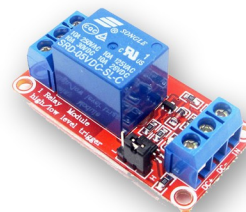

Servomotors

Specification:

- MG995
- 20KG
- 25KG
- 30KG



Planetary Gears Actuators

You will need

**Planetary Gears
Actuator
EBA17**

(x3)

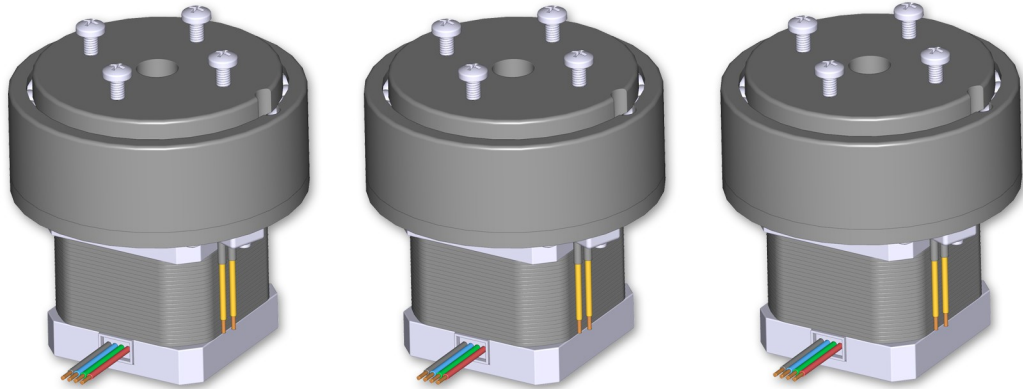

Planetary Gears Actuator EBA17 Nema 17

**Planetary Gears
Actuator
EBA23**

(x3)

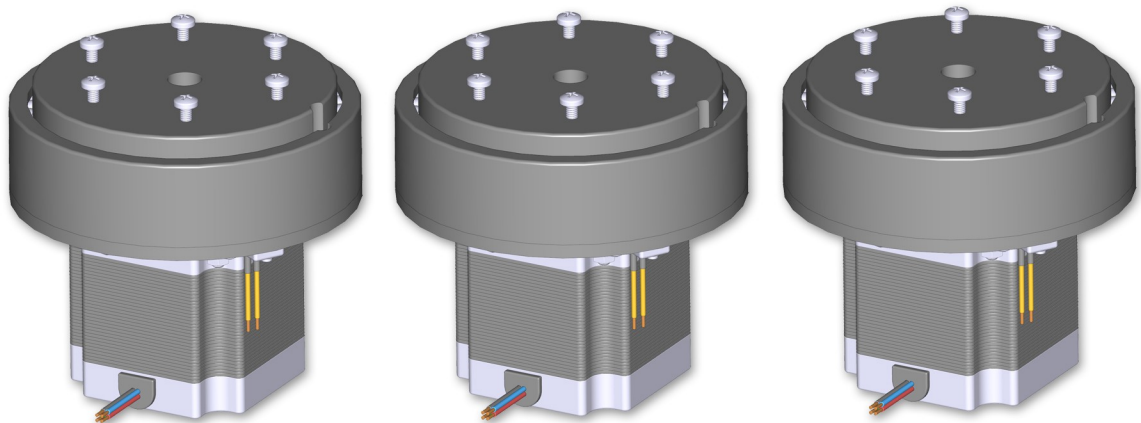

Planetary Gears Actuator EBA23 Nema 23

Power Setting & Wiring

Power

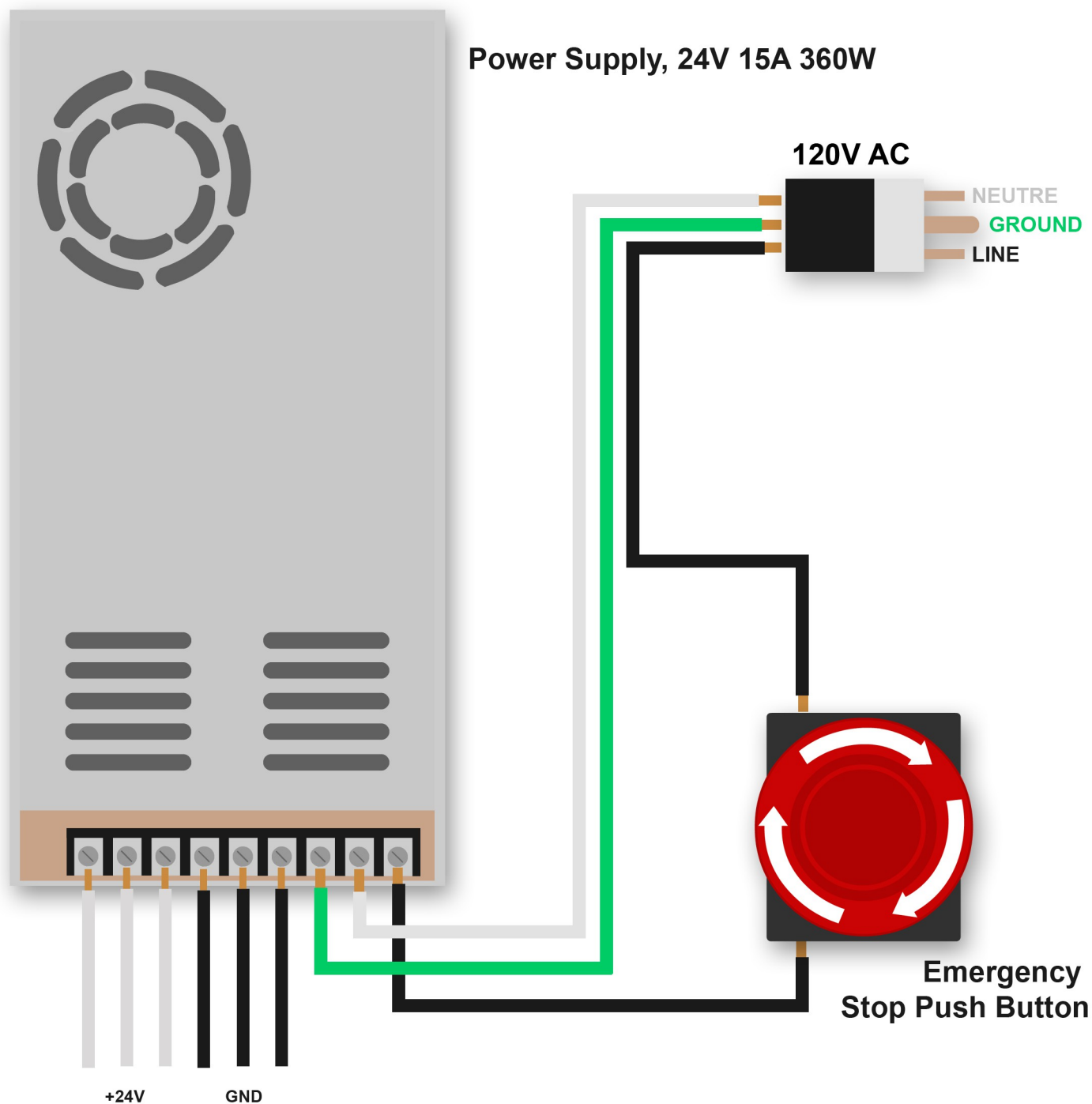

Assembling electrical machine components like power supplies, motors, drivers or other electrical components involves dealing with high voltage AC (alternating current) or DC (direct current) which can be extremely dangerous and needs high attention to detail, experience, knowledge of software, electricity and electro-mechanics or mechanics.

Microcontroller Setting & Wiring

Connect 1 servomotor to microcontroller

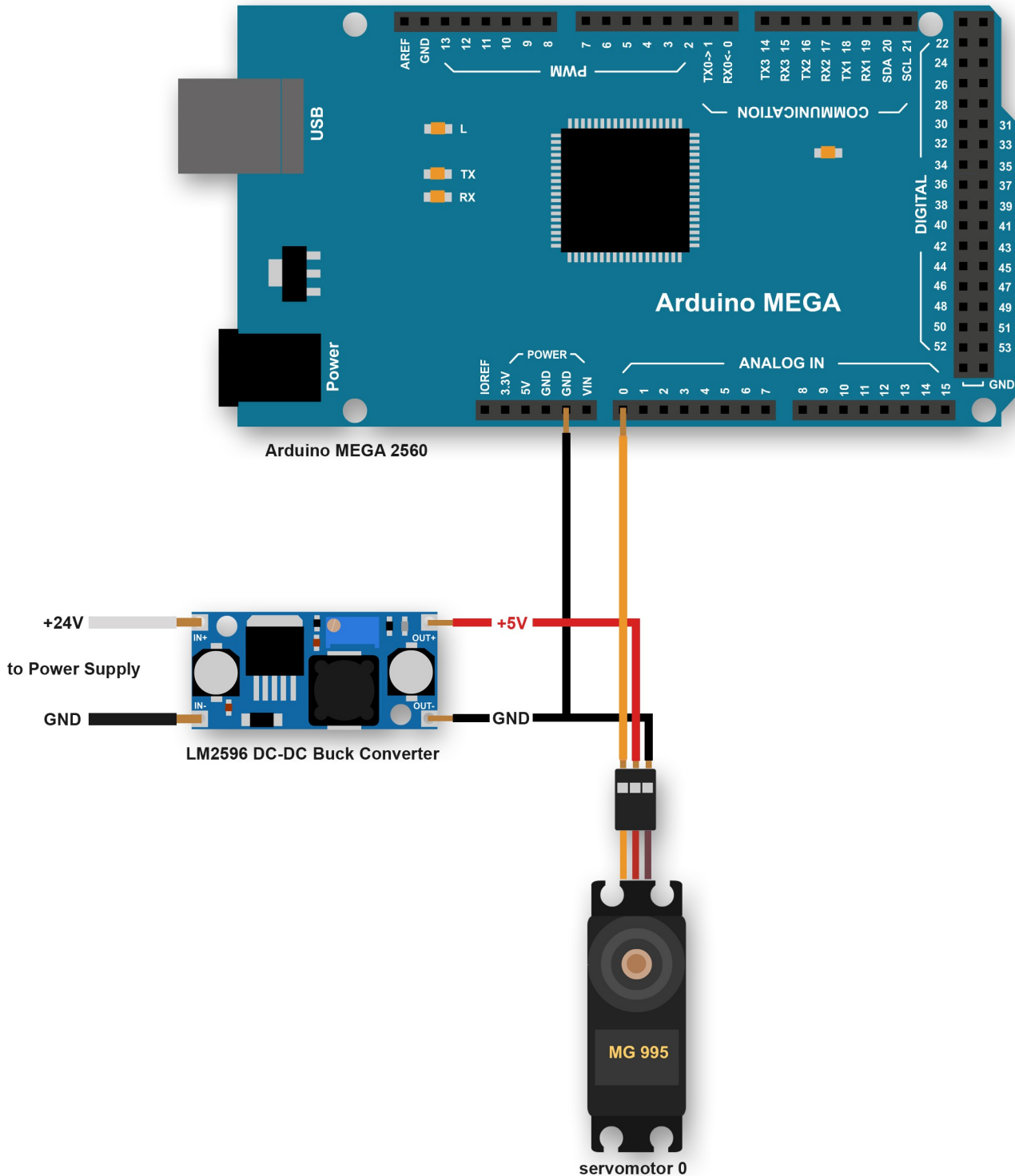

Microcontroller Setting & Wiring

Connect multiple servo motors to microcontroller

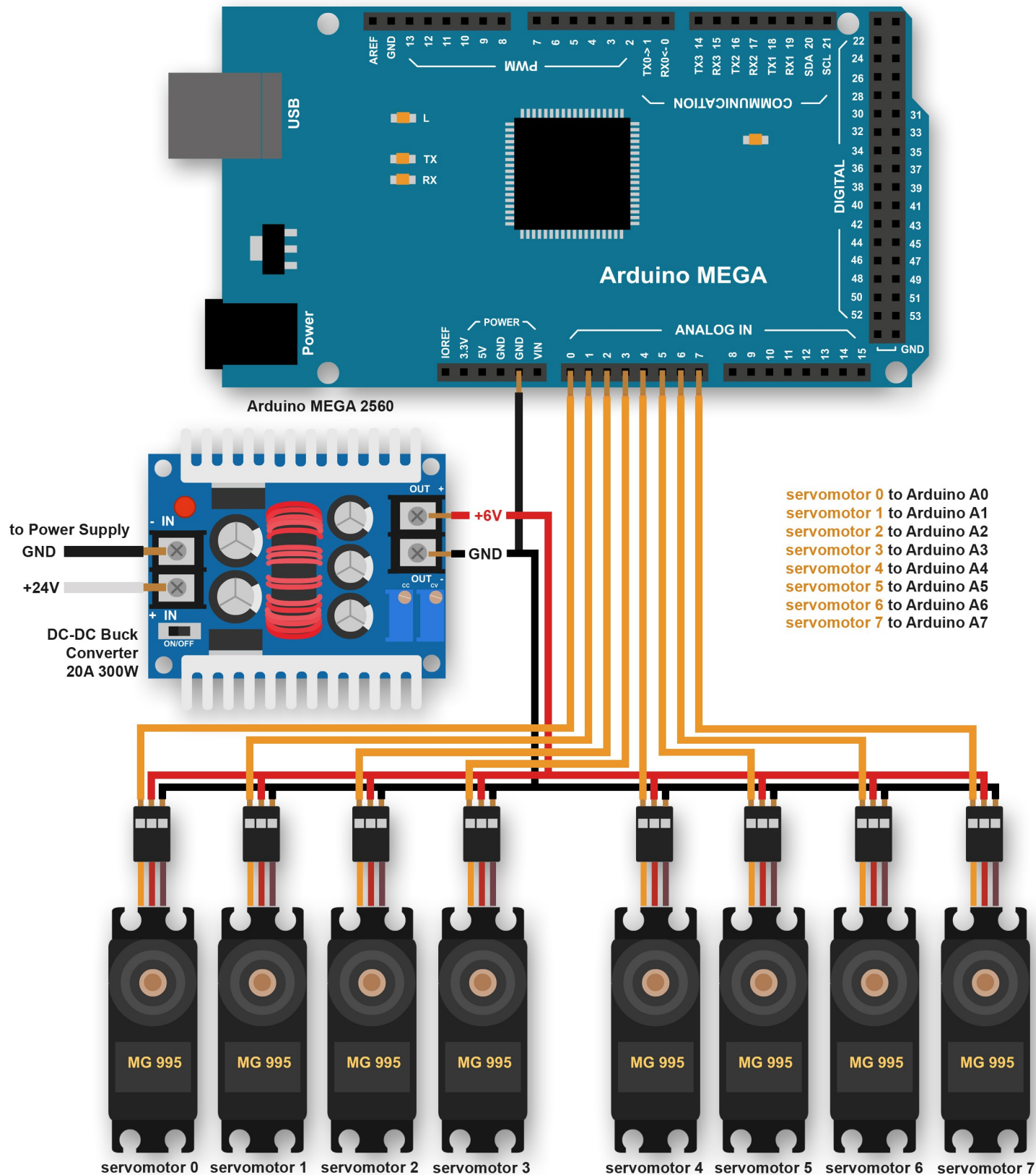

Microcontroller Setting & Wiring

Connect the input switches to the microcontroller

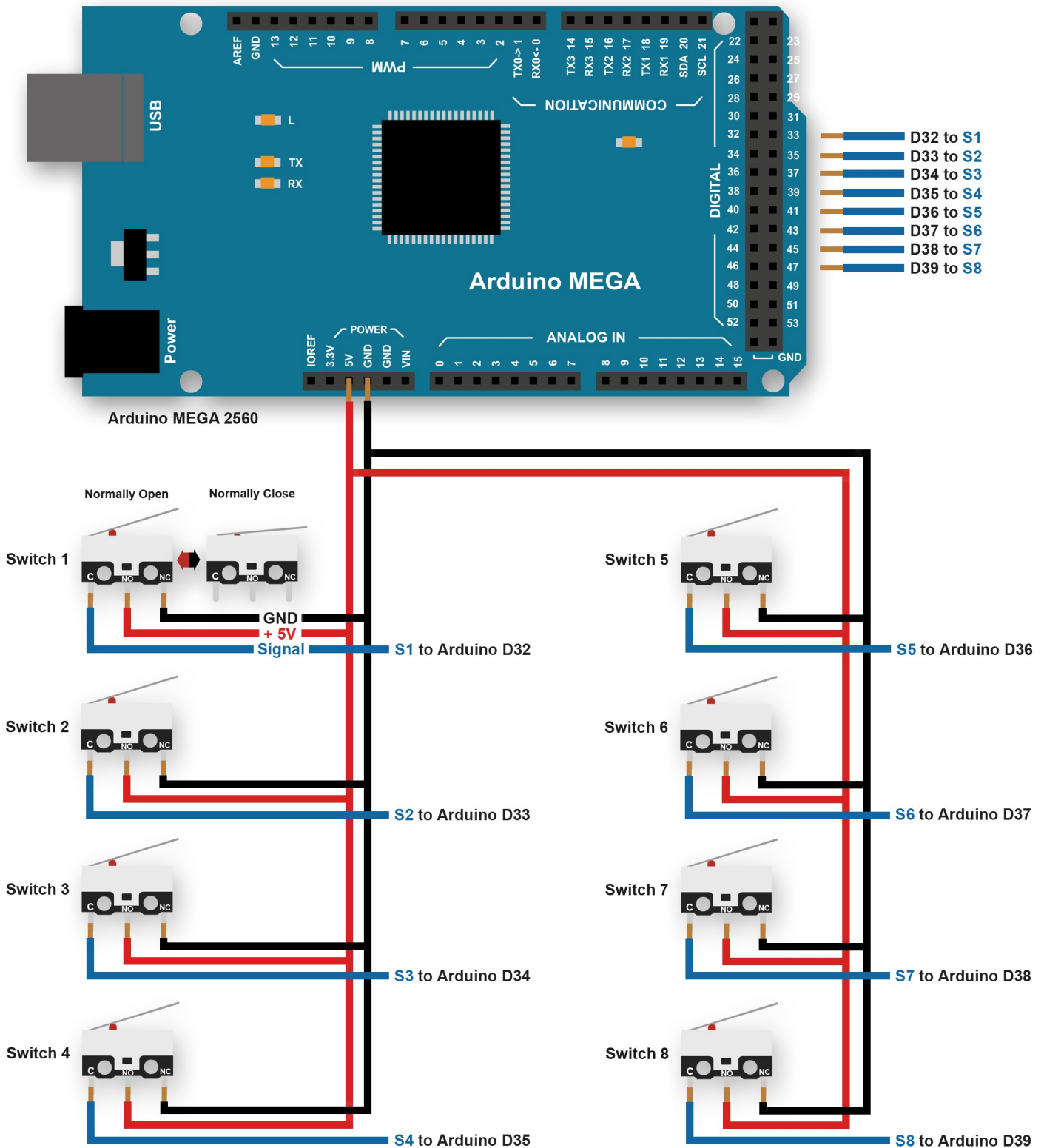

Microcontroller Setting & Wiring

Connect 8 Relay Board Module to microcontroller

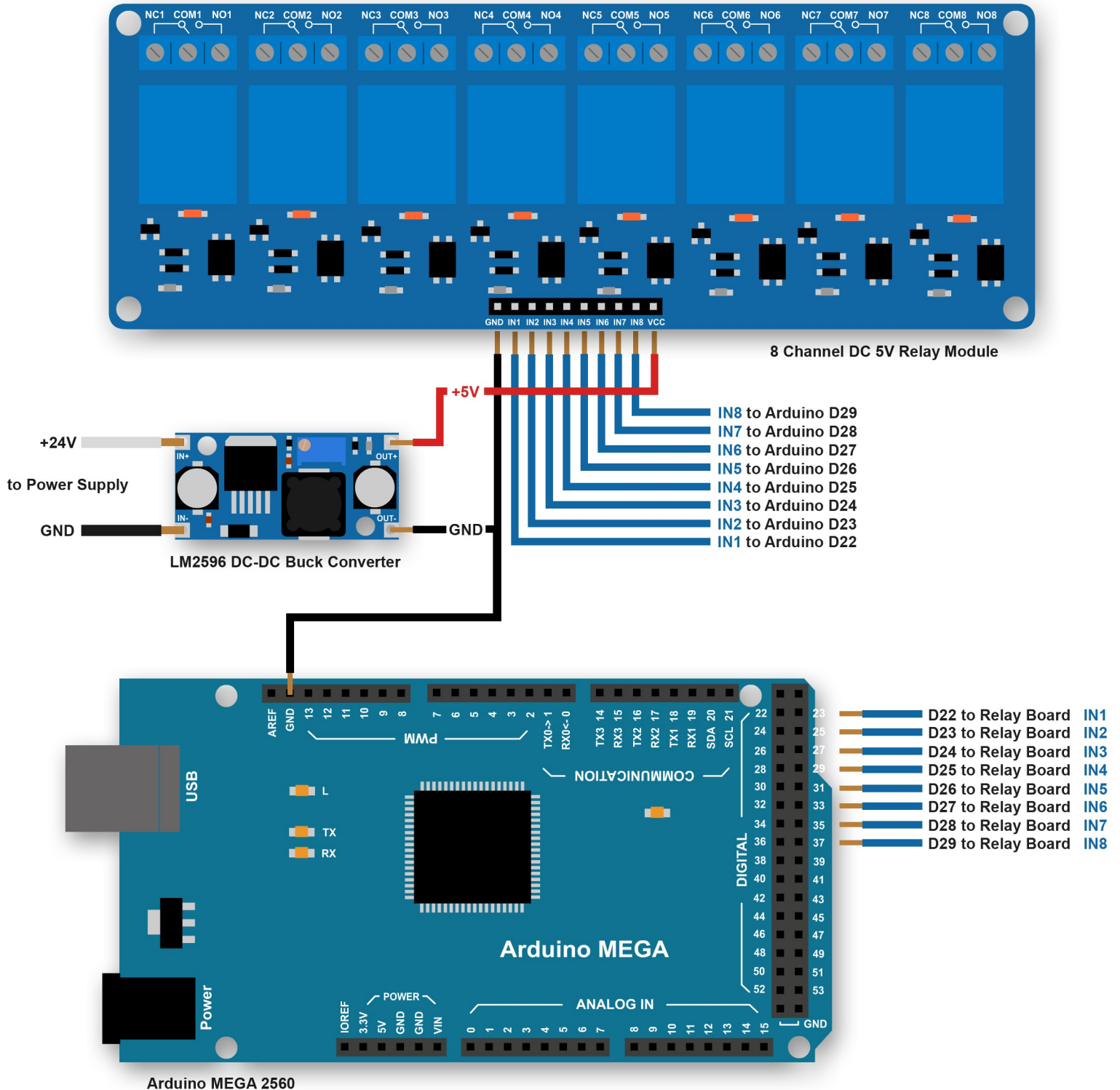

Microcontroller Setting & Wiring

Connect TB6600 motor drivers to microcontroller

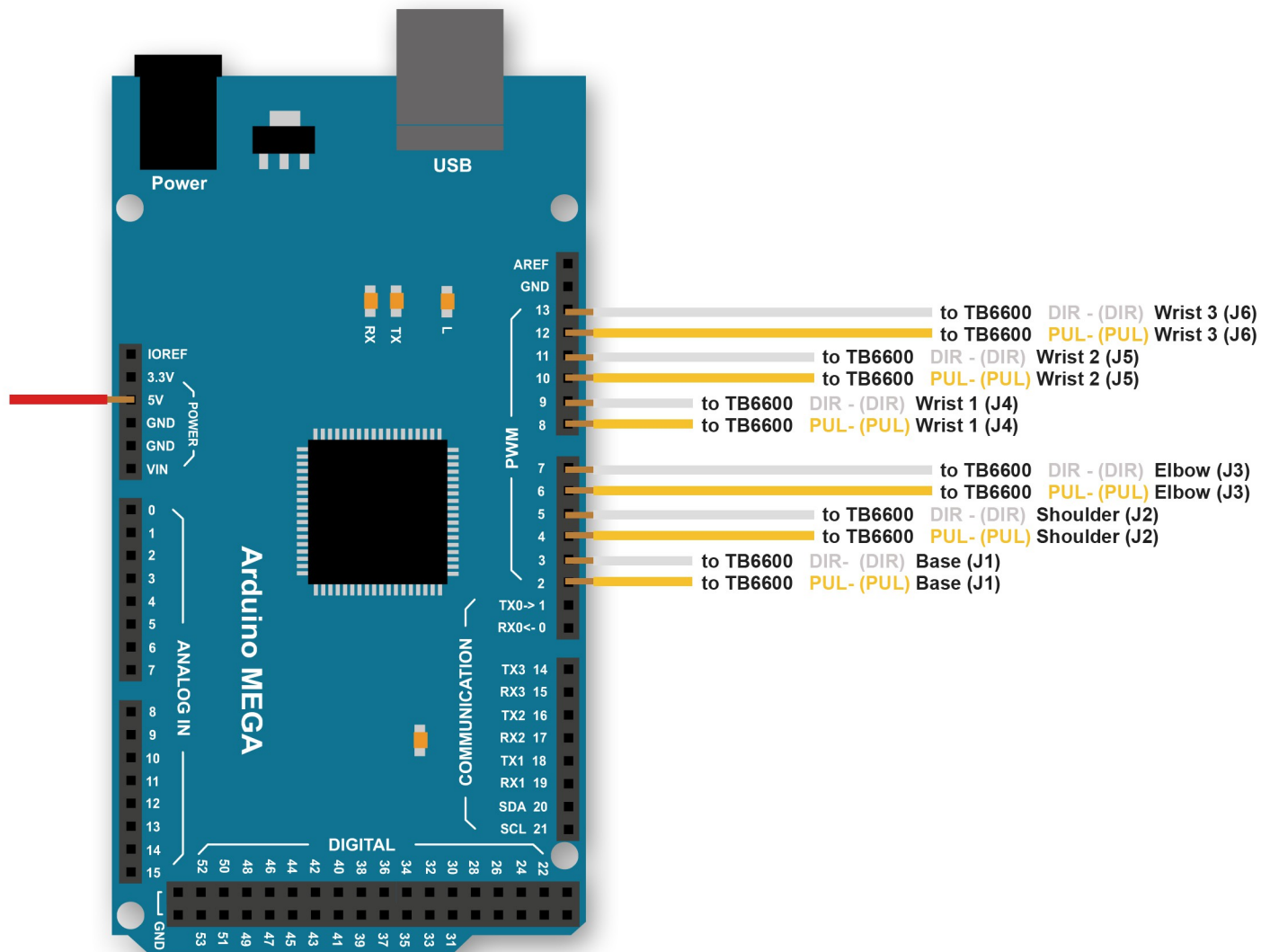

Cautions: Please power off and disconnect motor when plug or remove driver.

Motor Setting & Wiring - Base (J1)

Base J1 Setting

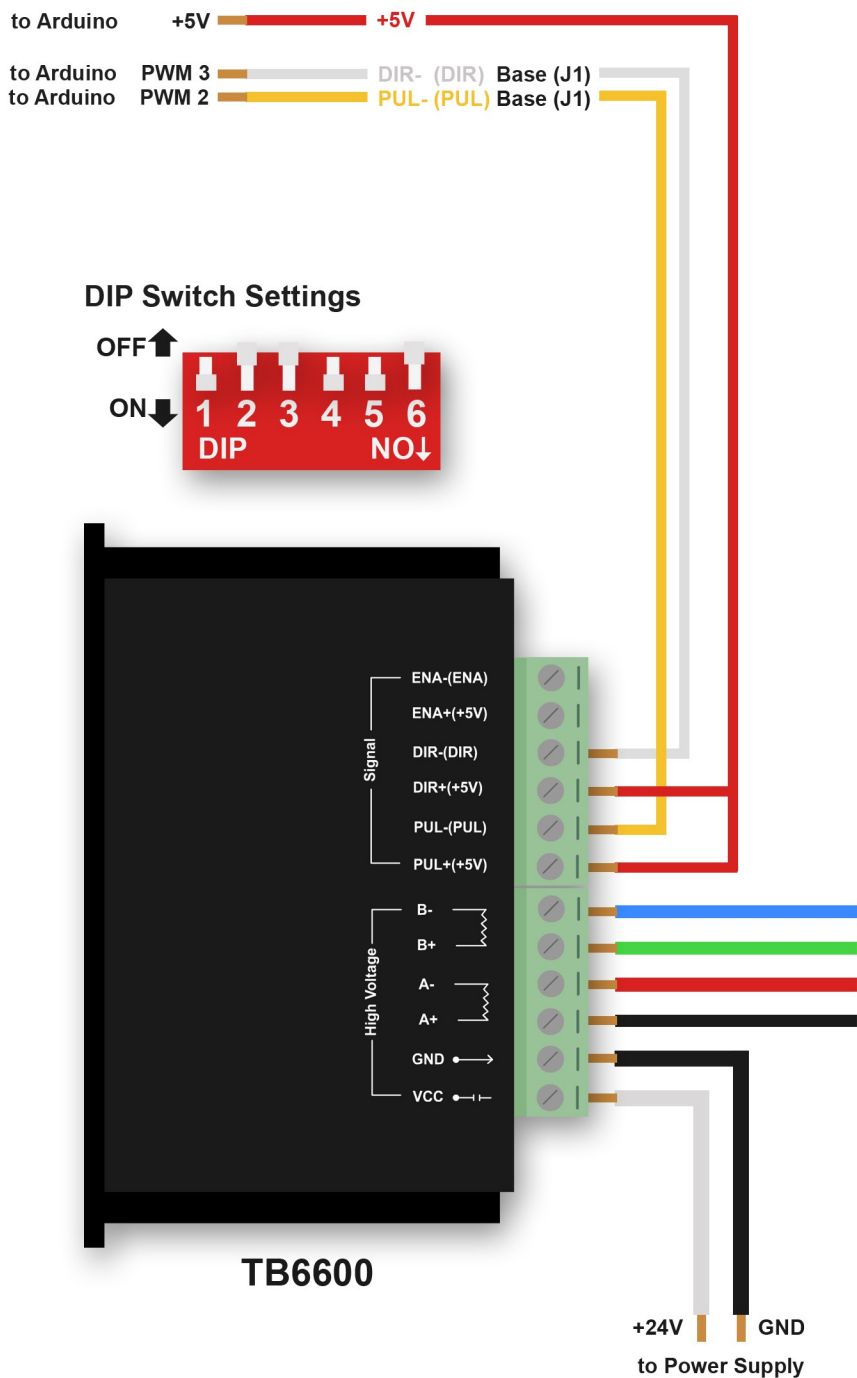

NEMA23 82mm with 4 wires

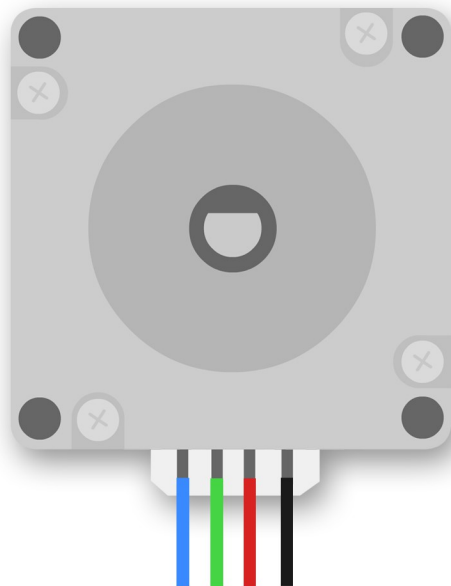

NEMA23 82mm with 6 wires



Cautions: Please power off and disconnect motor when plug or remove driver.

Motor Setting & Wiring - Shoulder (J2)

Shoulder J2 Setting

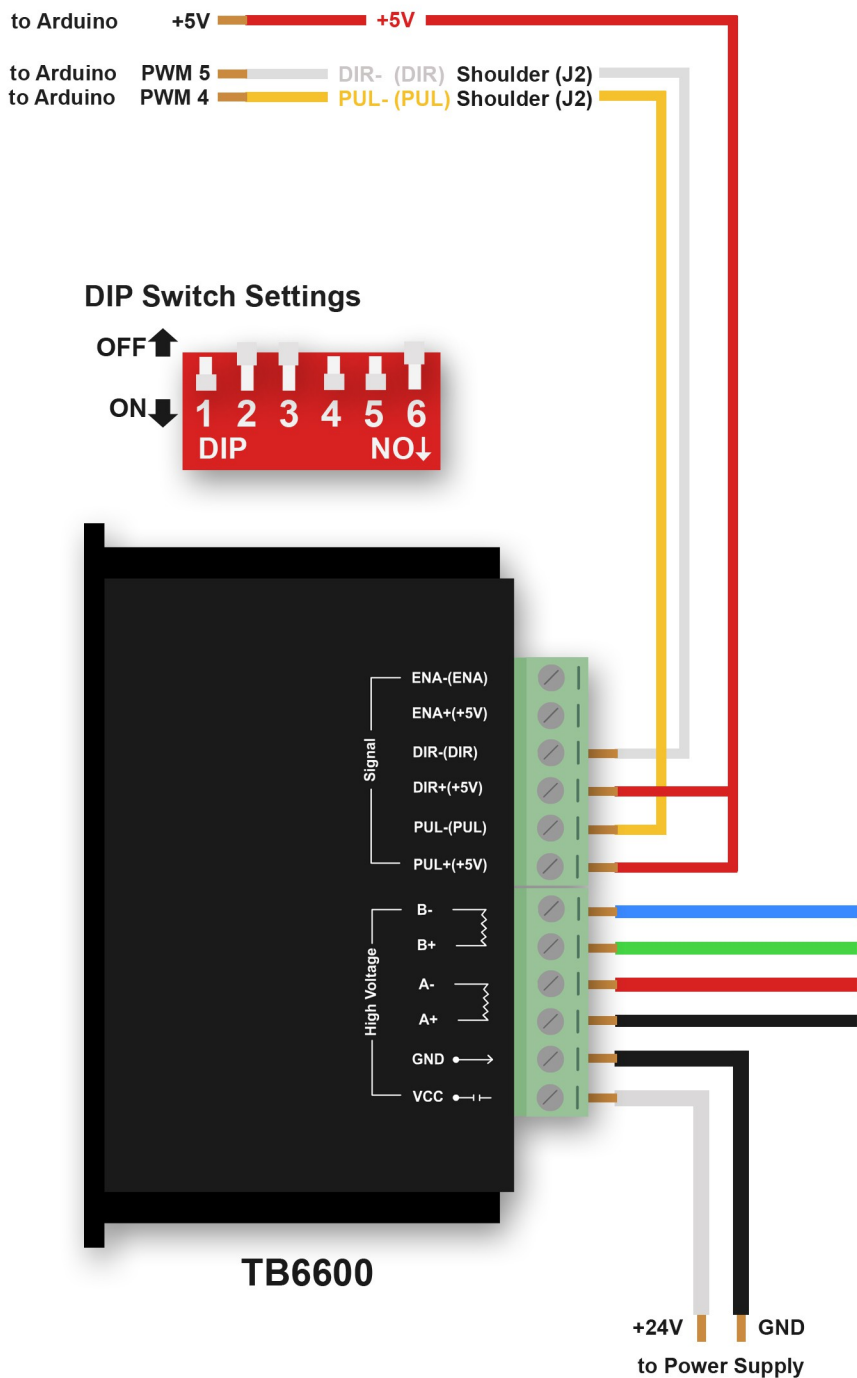

NEMA23 82mm with 4 wires

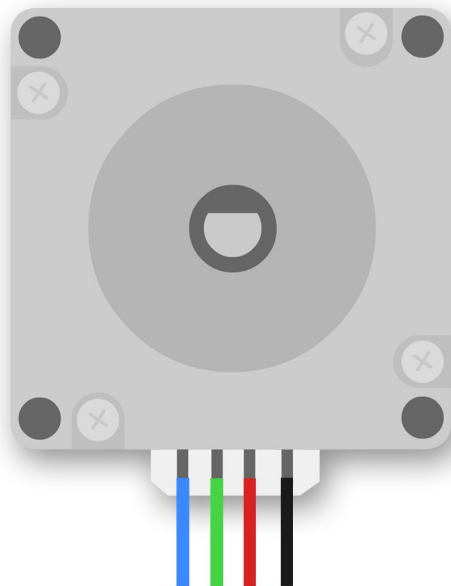

NEMA23 82mm with 6 wires



Cautions: Please power off and disconnect motor when plug or remove driver.

Motor Setting & Wiring - Elbow (J3)

Elbow J3 Setting

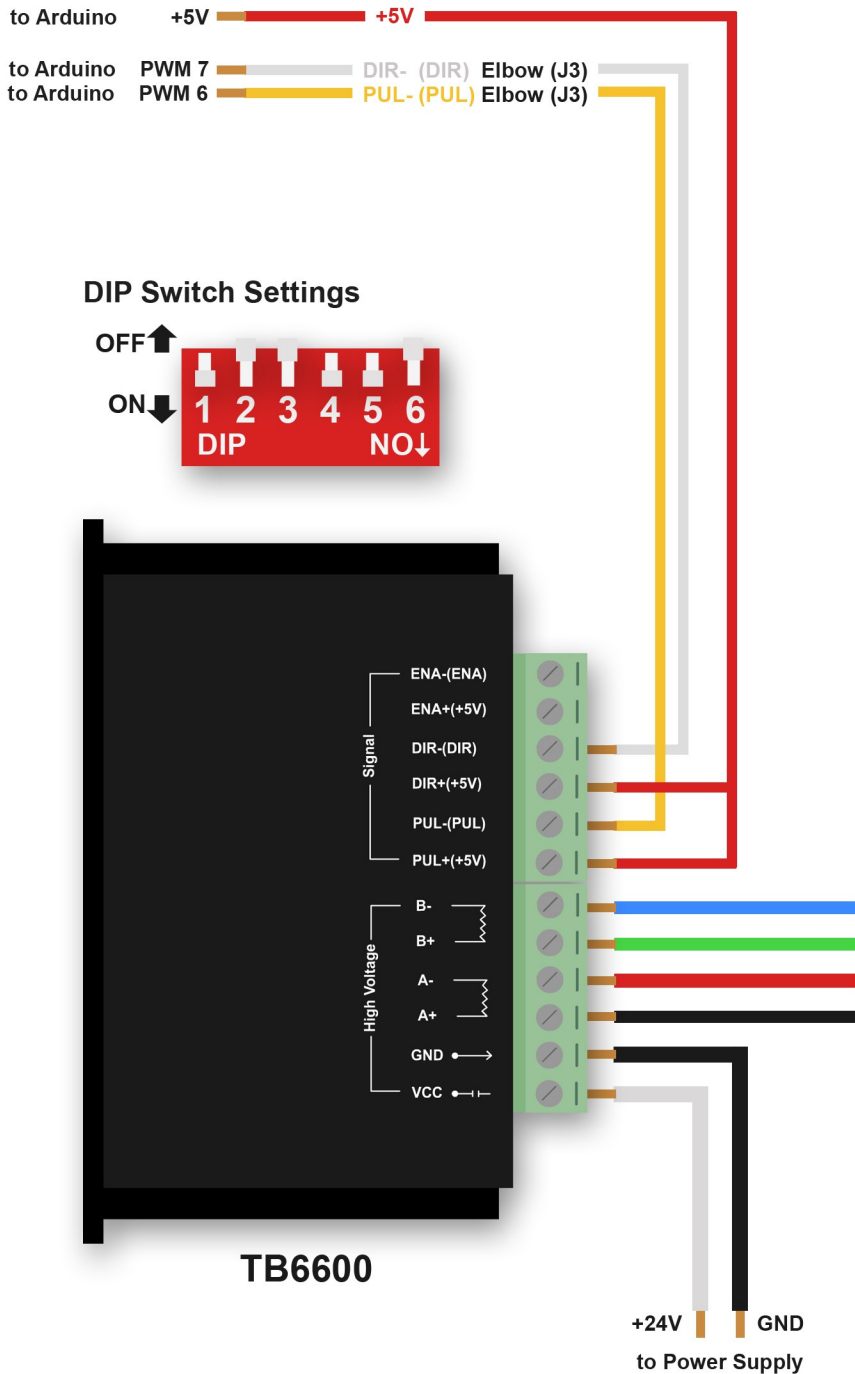

NEMA23 76mm with 4 wires

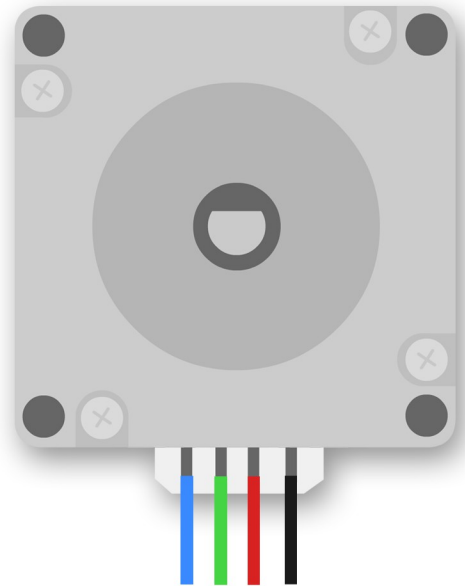

NEMA23 76mm with 6 wires



Cautions: Please power off and disconnect motor when plug or remove driver.

Motor Setting & Wiring - Wrist 1 (J4)

Wrist 1 J4 Setting

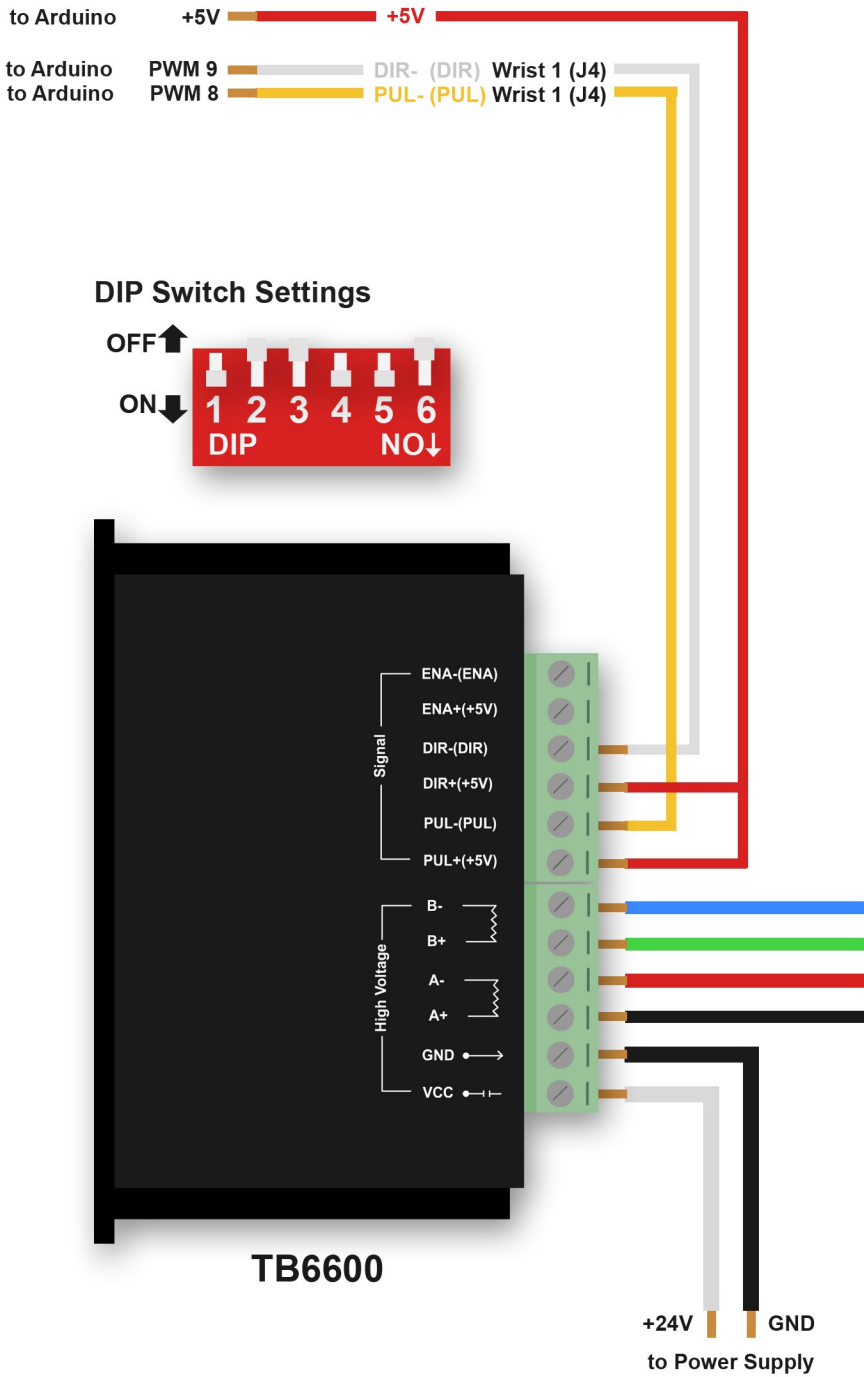

NEMA17 60mm with 4 pins

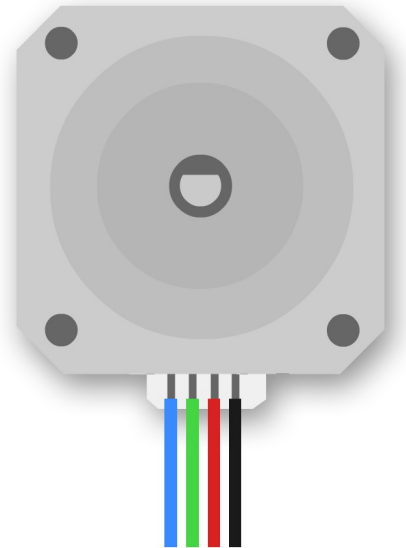

NEMA17 60mm with 6 pins

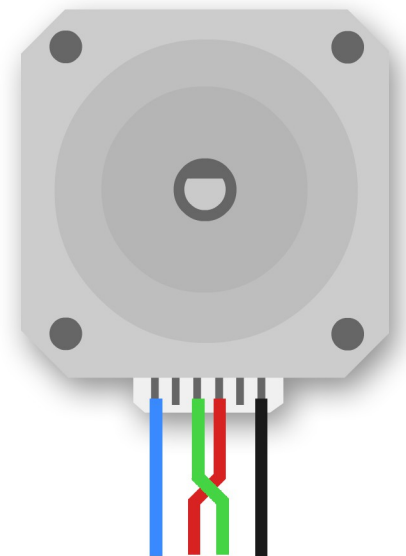

Cautions: Please power off and disconnect motor when plug or remove driver.

Motor Setting & Wiring - Wrist 2 (J5)

Wrist 2 J5 Setting

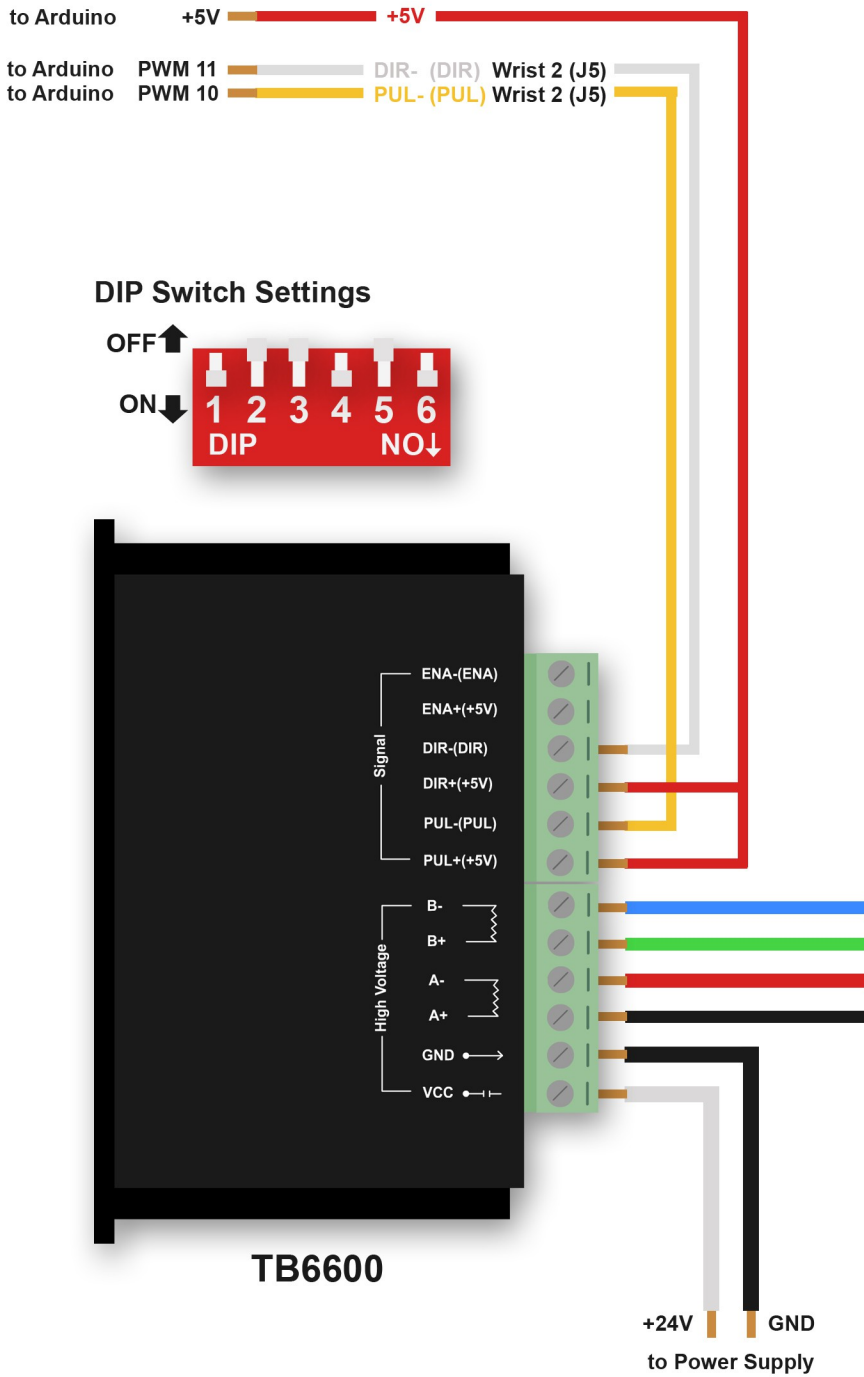

NEMA17 60mm with 4 pins

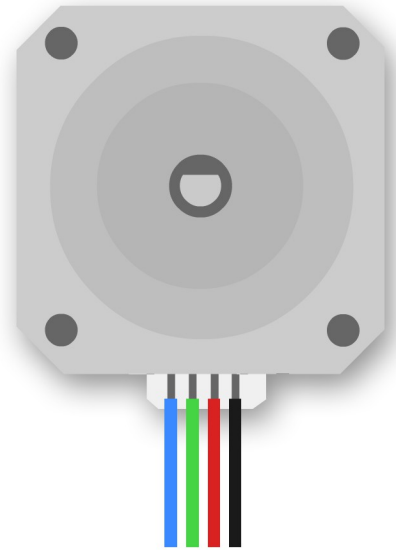

NEMA17 60mm with 6 pins

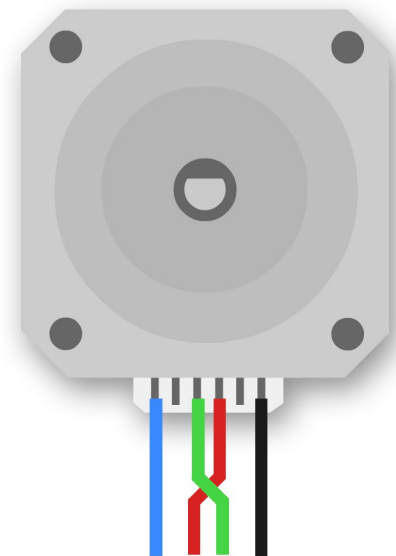

Cautions: Please power off and disconnect motor when plug or remove driver.

Motor Setting & Wiring - Wrist 3 (J6)

Wrist 3 J6 Setting

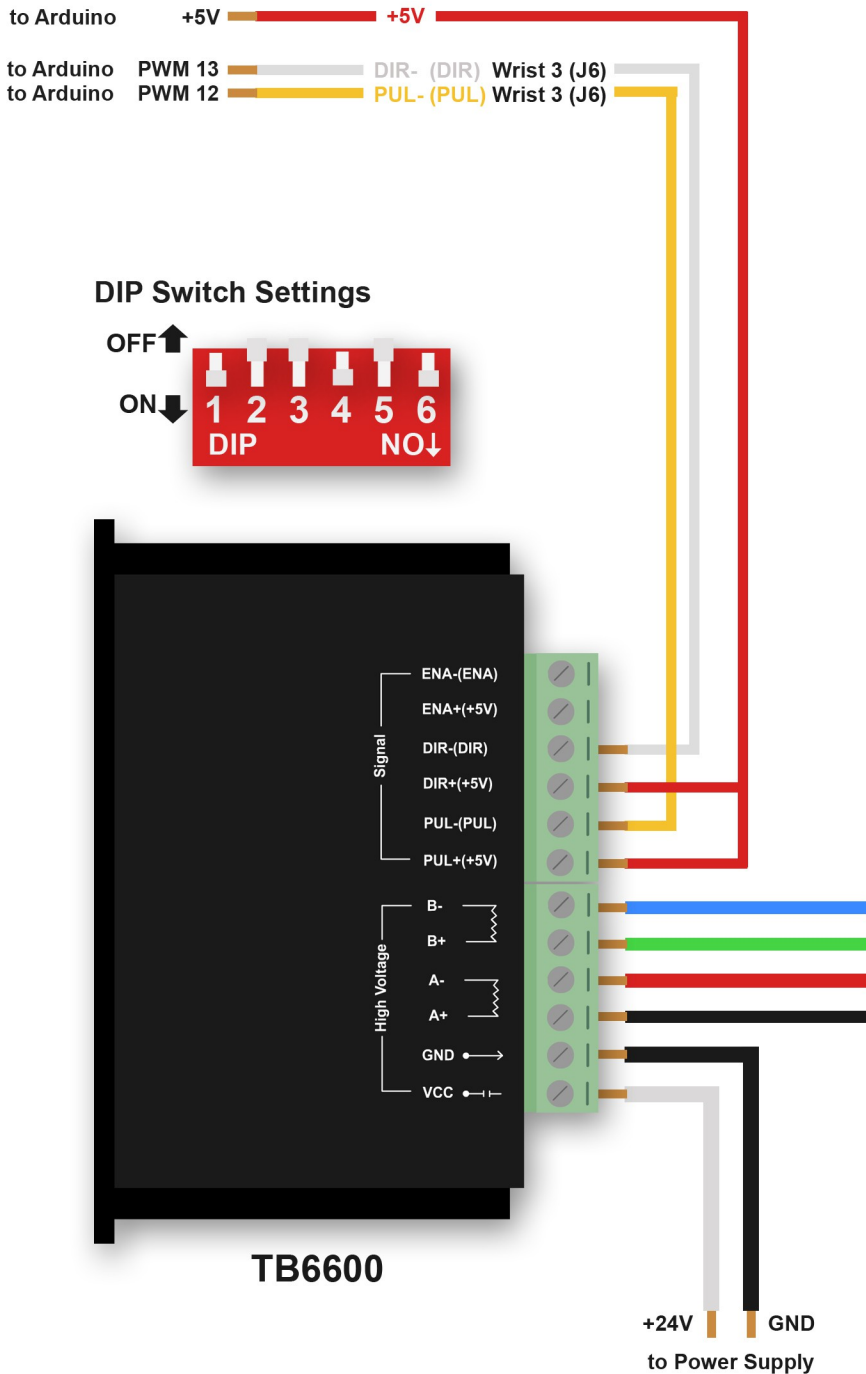

NEMA17 60mm with 4 pins

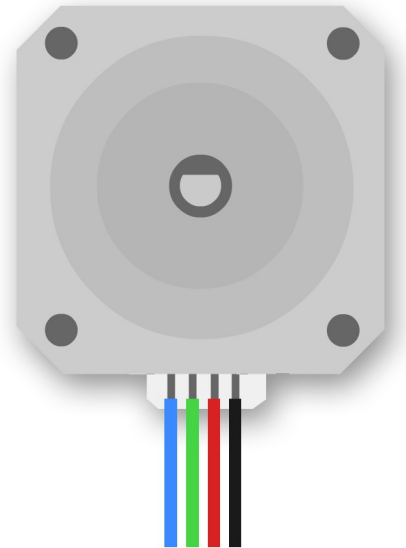

NEMA17 60mm with 6 pins

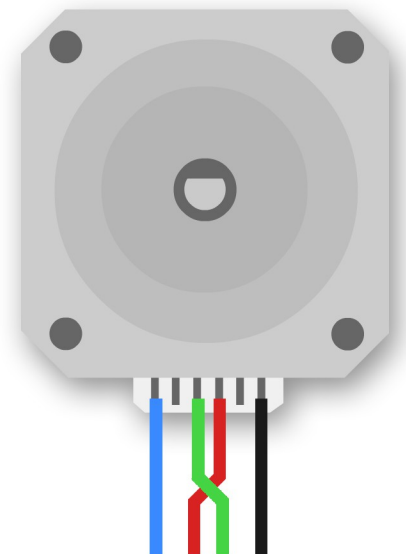

Cautions: Please power off and disconnect motor when plug or remove driver.