

CONVEYORS **TUFFBELT**

OPERATOR MANUAL & PARTS LIST



Machine Models

MINI 3M

MAXI 4.5M

OWNER NOTES

INDEX

EC declaration of conformity Page 4-5

User instructions Page 6

 1. Purpose and use Page 6

 2. Area of application Page 6

 3. Deployment options..... Page 6-7

 4. Entry into use..... Page 7-9

 5. Periodic inspection and cleaning Page 10

 6. Replacing components..... Page 11

 7. Transport and storage Page 12

 8. General safety instructions Page 13

 9. Safety instructions for hirers! Page 14

 10. User instructions for hirers! Page 15

Deployment diagram Page 15

Diagrams of accessories Page 16

Parts list..... Page 17

General assembly plan..... Page 18

Diagram switch box..... Page 19

Diagram accessories Page 19

Electrical circuit diagram..... Page 20

Emergency stop diagram Page 21

Owner Notes Page 22

Warranty Registration Form..... Page 23

Truxta Dealer & Contact Details Page 24

EC DECLARATION OF CONFORMITY

etramo bvba

Bisschoppenhoflaan 633

B-2100 Antwerpen

Tel.: 32/(0)3/326.02.92.

Telefax: 32/(0)3/326.51.62.

Email: info@etramo.be

EC declaration of conformity of a machine with the machinery directive (98/37/EC, amended by 98/79/EC) and the provisions implementing it in national legislation.

The manufacturer: **Etramo bvba**

Bisschoppenhoflaan 633

B - 2100 Deurne

België

hereby declares that the machine:

Conveyor belt

Type: **Mini-Maxi**

Serial number: 45S

--

Year of manufacture:

fulfils the provisions of the European machinery directive (directive 98/37, amended by 98/79/EC) and the provisions to implement it in national legislation,

and also fulfils the provisions of the following European directives:

- low voltage directive 73/23/EEC, amended by 93/68/EEC
- EMC directive 89/336, amended by 91/263/EEC, 92/31/EEC, 93/68/EEC, 93/97/EEC



At: Antwerp

10/09/2008

R. Tropato

Business Manager

UK & Eire: The range of Etramo manufactured conveyor belts are distributed in the UK by Tufftruk Ltd and branded Tuffbelt

EC DECLARATION OF CONFORMITY

etramo bvba

Bisschoppenhoflaan 633

B-2100 Antwerpen

Tel.: 32/(0)3/326.02.92.

Telefax: 32/(0)3/326.51.62.

Email: info@etramo.be

EC declaration of conformity of a machine with the machinery directive (98/37/EC, amended by 98/79/EC) and the provisions implementing it in national legislation.

The manufacturer: **Etramo bvba**

Bisschoppenhoflaan 633

B - 2100 Deurne

België

hereby declares that the machine:

Conveyor belt

Type: **Mini-Maxi**

Serial number: 3S

Year of manufacture:

fulfils the provisions of the European machinery directive (directive 98/37, amended by 98/79/EC) and the provisions to implement it in national legislation,

and also fulfils the provisions of the following European directives:

- low voltage directive 73/23/EEC, amended by 93/68/EEC
- EMC directive 89/336, amended by 91/263/EEC, 92/31/EEC, 93/68/EEC, 93/97/EEC



At: Antwerp

10/09/2008

R. Tropato

Business Manager

UK & Eire: The range of Etramo manufactured conveyor belts are distributed in the UK by Tufftruk Ltd and branded Tuffbelt

USER INSTRUCTIONS

1. PURPOSE AND USE

The conveyor belt has been designed to transport solid (non-liquid), non-dangerous materials such as sand, gravel, rubble, agricultural crops, etc.

The material being moved must be loaded on the conveyor belt with a sense of professional skill so that no damage is caused by overflowing.

A maximum of 3 conveyor belts of 3 metres can be linked in series on one 115V - 16A power supply (figure 5). A maximum of 2 conveyor belts of 4,5 metres can be linked in series on one 115 -16A power supply (figure 5). A large hopper is placed on the first conveyor belt (figure 1). This keeps the deposited material on the belt.

Each conveyor belt is held up by a trestle support (figure 3) or a set of pipes. Supporting pipes are provided in the frame for the assembly of a set of pipes.

2. AREA OF APPLICATION

The conveyor belt can be used in roofed areas as well as outdoors in humid environmental conditions.

3. DEPLOYMENT OPTIONS

The conveyor belts are separate from each other and can be deployed in series.

They must be deployed in a way that ensures they cannot shift, i.e. the chair or pipes construction must stand on a solid foundation.

The conveyor belt cannot be supported by the small hopper.

In the longitudinal direction they can be placed at any angle to the previous conveyor belt.

The conveyor belt must always be filled via the large hopper, i.e. items must never be filled directly onto the belt.

The conveyor belt must always be level in the width direction. This is to prevent the belt from slanting.

The rubber belt must be able to run unimpeded on the underside of the conveyor belt without touching the ground or any other obstacle. Filling between rubber conveyor belt spaces must absolutely be avoided.

The following deployments are possible:

1. **Deployment in a straight line and deployment on a slope in series (figure 5).**
 - The conveyor belts cannot be placed on top of each other.
 - The conveyor belt sits on the ground on the filling-side.
 - At the output side, the conveyor belt sits on a chair, set of pipes or (for example) a container.
 - The conveyor belt is positioned in such a way that the output of the material ends up in the small hopper (fig.2).
 - The gradient depends on the type of the materials being transported and their weight.

2. **Deployment where the conveyor belts are not placed behind each other.**
 - The conveyor belts can be deployed and arranged at every angle.
 - The conditions for deployment are the same as in point 1.

IMPORTANT: read all of the information stickers on the machine very carefully

Please refer to the next chapter ‘Entry into use’ for information on linking several conveyor belts.

4. ENTRY INTO USE

When using the conveyor belt for the first time, it might need to be adjusted. (see paragraph 6.4)

Each conveyor belt is supplied with a power cable that enables the user to connect the device to the 230V mains network.



- **3M:** the consumption per conveyor belt is 4,6 A.
- **4.5M:** the consumption per conveyor belt is 5,0 A.

USER INSTRUCTIONS

If the conveyor belt is overloaded the motor stops thanks to the built-in thermal fuses in the motor and switch unit.



It is advisable to start the conveyor belt unloaded to prevent the thermal fuses on the motor and/or switch from triggering.

In certain circumstances (non-overloaded belt and small slope), the conveyor belt can nonetheless be started while loaded.

WARNING: if the belt does not start to move, switch off the motor immediately.

Linking Several Conveyor Belts.

3M: when the conveyor belt enters service the user must ensure that the leads cannot be damaged. A maximum of 3 conveyor belts of 3 metres can be connected behind each other using a secured 16 A mains power supply. The conveyor belts can be coupled via a linking lead so that a separate power supply (115V) does not have to be provided for each belt.

4.5M: when the conveyor belt enters service the user must ensure that the leads cannot be damaged. A maximum of 2 conveyor belts of 4,5 metres can be connected behind each other using a secured 16 A mains power supply. The conveyor belts can be coupled via a linking lead so that a separate power supply (115V) does not have to be provided for each belt.

The last conveyor in the series must be equipped with an end plug.



3M: if the user wishes to use more than 3 belts, a separate mains power supply must be provided for every 3 conveyor belts.

4.5M: if the user wishes to use more than 2 belts, a separate mains power supply must be provided for every 2 conveyor belts.

Each conveyor belt can be started separately by using the start button. The start button is green in colour. A red (emergency) stop button is located at the end sides of the conveyor belt.

'Stop' not only halts the conveyor belt on the machine where the stop button was pressed but also all conveyor belts that are connected to the same power supply.

Only switch on live power to the conveyors when ALL conveyors have been fully set-up and electrically connected!

Never connect/disconnect or clean conveyors that are attached to live power!

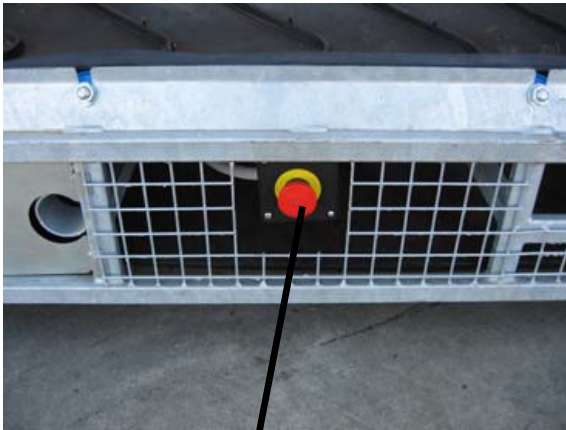

EMERGENCY STOP

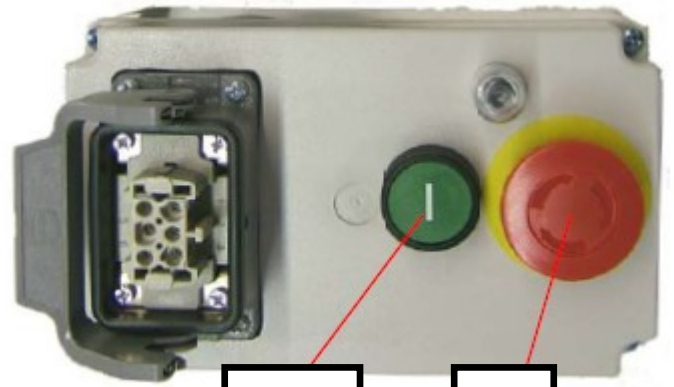

START

STOP



CONNECTING TABLE

When restarting the conveyor belt, the various conveyor belts all have to be started up separately. Always start the last one in the series first.

Installation of a large hopper (figure 1 page 16).

A large hopper is placed at the start of the first conveyor belt (figure 5 page 15).



Installation of a small hopper (figure 2 page 16).

A small hopper is fitted on the piling-up side of the conveyor belt above the support groove (figure 5 page 15).



SUPPORT GROOVE



5. PERIODIC INSPECTION AND CLEANING

See assembly plan (page 18)

1. Inspection:

The driving roller, accompanying roller and trough rollers must be checked regularly and cleaned if necessary.

It is very important for no material residue to be left behind on the roller. Conveyed material that gets stuck between the roller and belt can be very damaging and can lead to the system breaking. Also inspect the operation of the belt scraper regularly.

2. Cleaning

The conveyor belt can be rinsed with a water hose (maximum pressure: 5 bar)

WARNING:

Caution is advisable when you perform the task.

Uncouple the conveyor belt from the power supply!

Do not aim the water hose directly at the electricity box.

Never scrape the belt or drums with your hands or sharp objects.

6. REPLACING COMPONENTS

See assembly plan (page 18)

Replacing the rubber belt:

1. Dismantling the rubber belt:

Method and sequence:

- Detach bolts no.6.
- Remove intermediate part no.5 at the front of the conveyor belt.
- Detach the cover plates no.18
- Remove belt scraper no.9 by pulling it over the hinge points (side by side).
- Loosen nuts no.14 and remove supporting roller no.16.
- Unblock nuts no.3 and take the depth at which bolts no. 4 are screwed in as the reference measurement.
- Loosen bolts no.4 (fully).
- Lift the accompanying roller out of the groove (upwards) and take it out of the frame.
- Hook the belt above the guidance grooves.
- Take the rubber belt away, starting with the driving roller.
- **IMPORTANT: make sure that the driving roller does not move out of the slides!**
- Ensure that the motor cable is lying in the safety groove.

2. Assembling the rubber belt.

Method and sequence:

- Assemble the belt in the reverse order to dismantling.

3. Adjusting the rubber belt for tension.

Method and sequence:

- Screw bolts no.4 tight alternately until the tightening depth is reached!

4. Adjusting the rubber belt for parallelism.

Method and sequence:

- If the belt runs against the frame on one side, tighten screws no. 4 by a ¼ turn at the side where the belt touches the frame (or loosen the screws on the opposite side).
- Allow the belt to turn by a few belt lengths and check it in the meantime.

WARNING: CAUTION is advisable.

This work is NEVER done while the conveyor belt is running or electrically powered.

AVOID ACCIDENTS.

IMPORTANT:

- Never replace parts when the belt is electrically powered.
- Only use original components at replacement.
- Replacements or repairs other than those listed in these user instructions (especially the electrical aspects) can only be executed by technically competent staff).

USER INSTRUCTIONS

7. TRANSPORT AND STORAGE

1. Transport:

Two people can easily move the conveyor belt. To do this use the specially designed wheel system (see figure 6 page 16). These carrying wheels are a handy means of transport, even on uneven ground.

Using the Wheel system:

Lift-up the conveyor belt on the side where the wheel system is being mounted (see fig. 6-A page 16) and fit the wheel system into the opening provided (fig. 6-B page 16).

The conveyor belt can now be lifted on the other side and moved along.



2. Storage

A maximum of 6 conveyor belts can be placed above each other.

When stacking, the semi-circular support rings are placed in the grooves on the conveyor belt lying beneath (figure 4 page 16).



8. GENERAL SAFETY INSTRUCTIONS

IMPORTANT

- People cannot 'hitch a ride' on the Mini-Maxi in any circumstance.
Keep children away.
- If the Mini-Maxi is deployed at a height, all precautions must be taken to prevent conveyed material from falling out (e.g. onto staff).
- The Mini-Maxi can never be deployed in a position where the electrical contacts are underwater.
- If the deployed installation becomes blocked during use, all conveyor belts must be halted before the cause is removed.
- Never work on the conveyor belt while it is electrically powered.
- The conveyor belt can be rinsed with a maximum water pressure of 5 bar.

USER INSTRUCTIONS

9. SAFETY INSTRUCTIONS FOR HIRERS

To ensure safe, correct use of the machine, you must read this text thoroughly in advance.

Do not allow the conveyor belt to be used by minors or unauthorised persons.

Keep other people at a distance and never leave the conveyor belt unsupervised.

Children or anyone else can never 'hitch a ride' on the conveyor belt in any circumstance.

Only use the conveyor belt for materials that are not harmful or dangerous.

Never transport materials that could adversely affect or damage the conveyor belt.

Load the material on the conveyor belt in a way that ensures nothing can fall off over the side.

Start the conveyor belt unloaded to prevent the fuses from switching off the power.

If the machine is overloaded the thermal fuse switches the motor off. Wait for some time. The conveyor belt can only be restarted with the start button when the fuse has been restored to its original state.

Stack a maximum of 3 conveyor belts on top of each other during storage or transport.

10. USER INSTRUCTIONS FOR HIRERS

The conveyor belts can be set up behind each other. Begin at the end point and install a small hopper. Put the end of the next conveyor belt above it with a chair construction that sits on the ground. Ensure that it is deployed in a stable way. Also ensure that the conveyor belts cannot shift.

Equip the first belt with the large filling hopper, especially on a steep slope. When deploying on a slope the conveyor belts must be supported separately with a sturdy pipe construction.

Build the construction based on the pipe provided in the frame.

Ensure that the conveyor belts themselves can always run unimpeded on their underside without touching the ground or another obstacle.

The conveyor belts can only be deployed at an angle in the longitudinal direction. In the width direction they must always be level to prevent the belt from slanting.

The gradient is limited by the type of material being transported and its weight.

The conveyor belts can also be deployed in a falling line.

Connecting leads are used for coupling. Ensure that these cannot be damaged or dragged along. Only use the electrical lead of the belt itself in dry weather conditions. If the conveyor belt is used in humid conditions connect the electricity directly to the built-in socket. During set-up prevent electrical parts from being able to slip underwater.

For 3M – Connect a maximum of 3 conveyor belts electrically on a 16 A power supply.

For 4.5M – Connect a maximum of 2 conveyor belts electrically on a 16 A power supply.

Use extension leads (minimum 2.5 mm²) with an earth and always roll them out in full. Always ensure that the power supply is equipped with a differential switch and an earth leak switch.

The conveyor belt is activated by using the green start button. The red button halts the belt of all conveyor belts that are connected to the same power supply.

After the electricity is switched off, the machine is to be rinsed with a water hose and thoroughly cleaned.

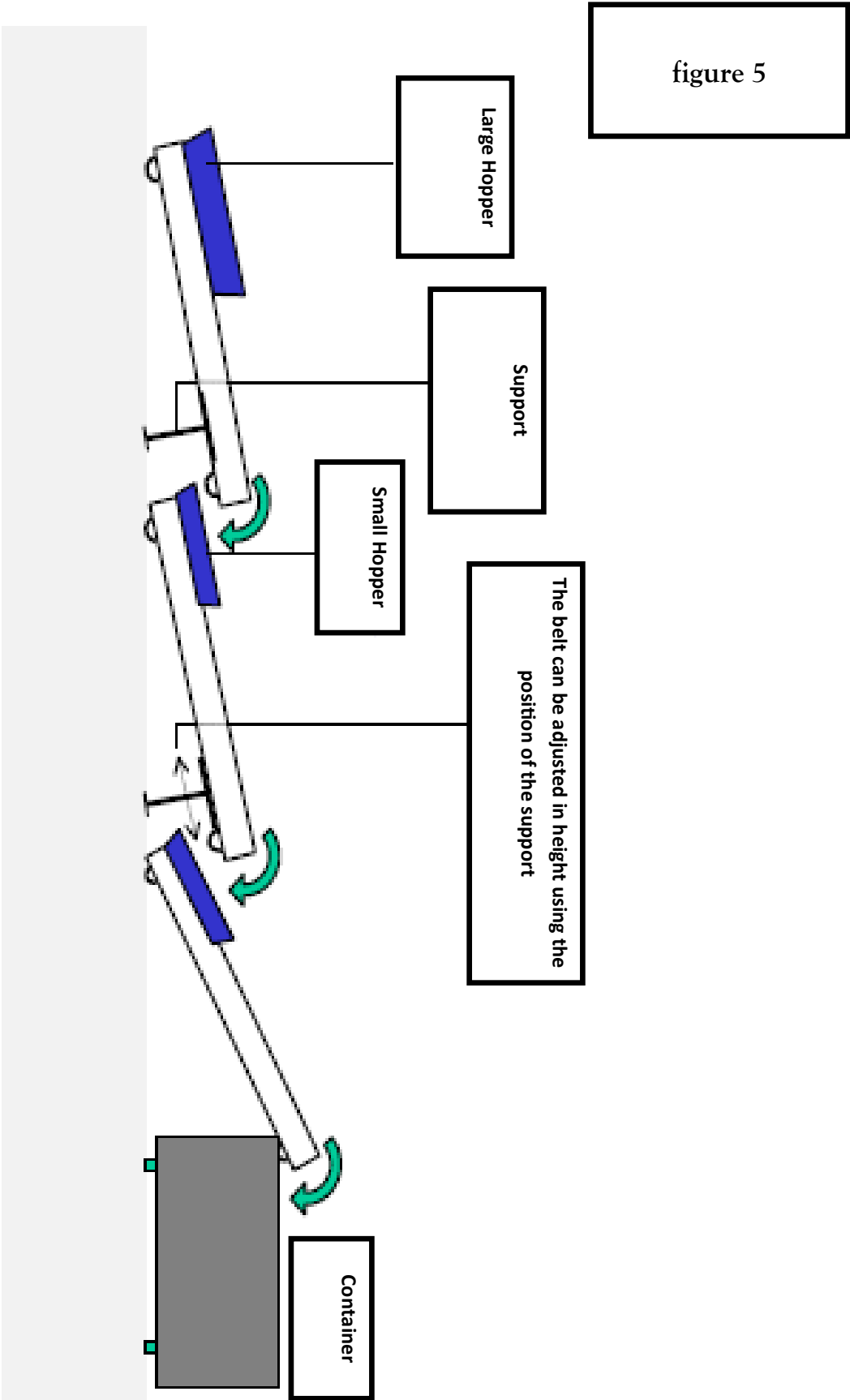
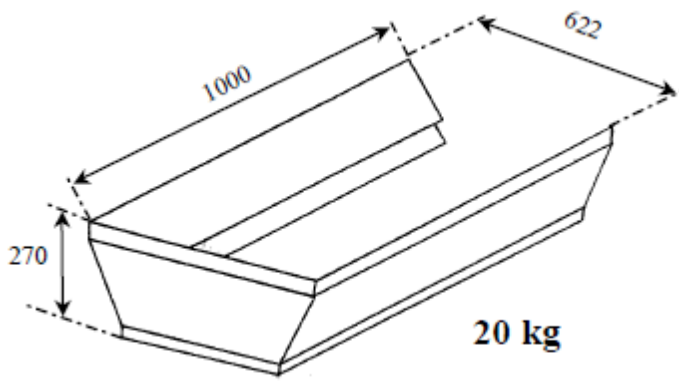
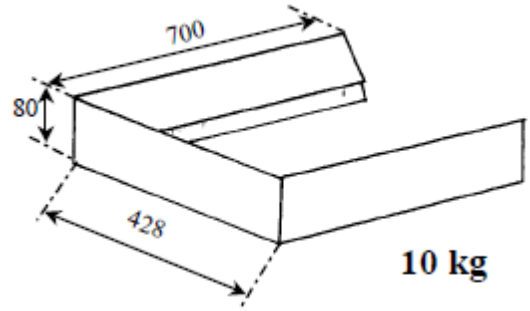

DIAGRAM OF ACCESSORIES



Large Hopper - fig.1



Small Hopper - fig. 2

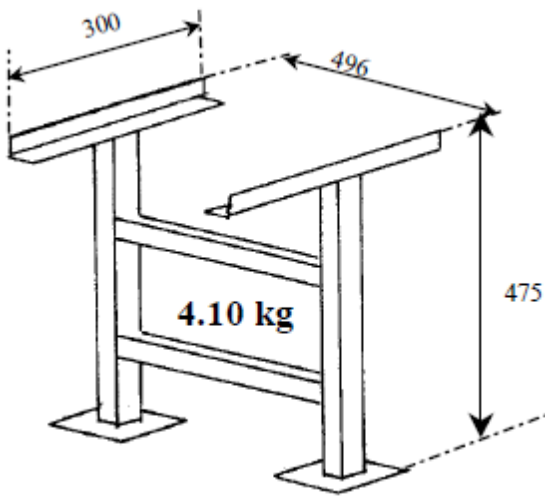

Support - fig. 3

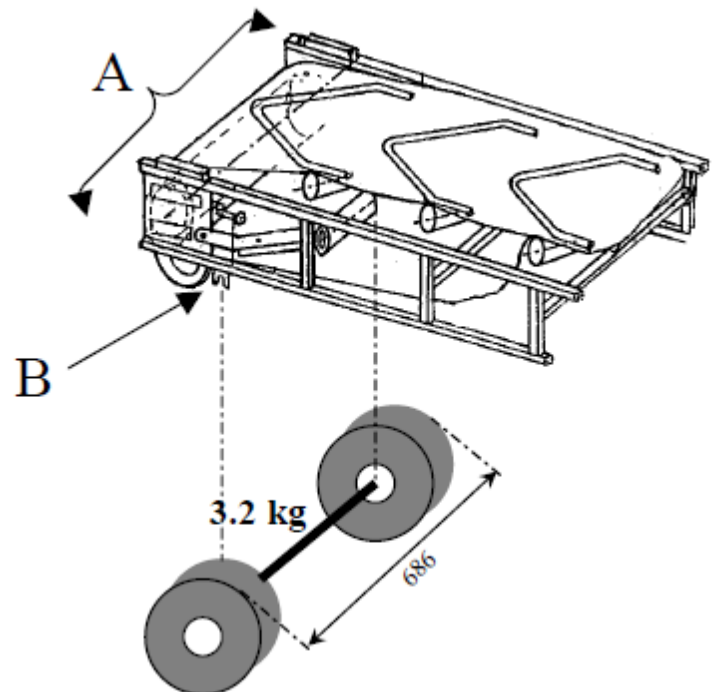

Transport Wheels - fig. 6

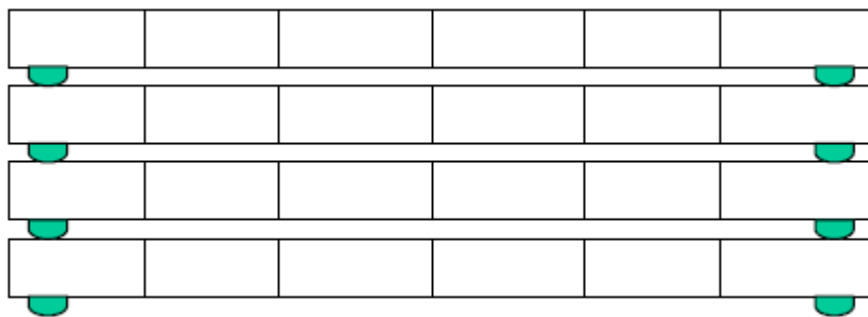

Stacking - fig. 4

Item No.	Part No.	DESCRIPTION
1	107-00801	Frame end cap - black
2	107-00711	Return roller type D
3	8-10003	Nut M10
4	7-10110	Set screw M10 x 110
5	107-00831	Connecting piece
6	7-8020	Set screw M8 x 20
7	8-8001	Nut M8
8	107-01657	Decal Wheel set 50kg (3m conveyor belt)
8a	107-01658	Decal Wheel set 70kg (4,5m conveyor belt)
9	107-00853	Belt scraper complete
10	107-01395	Belt scraper complete metal bar (set)
11	107-00544	Decal direction of rotation
12	107-01807	6 Pole Socket outlet
13	107-00886	Roller diam.50 L=185
14	8-12006	NyLock nut M12
15	4-1204	Washer M12
16	107-00733	Support roller
17	107-01710	Emergency stop button complete
18	107-01540	Side plates (set of 4 pieces)
19	107-00885	Chassis conveyor belt complete (3m conveyor belt)
19a	107-00863	Chassis conveyor belt complete (4,5m conveyor belt)
20	107-00421	Decal 110V
21	107-01882	Control box model -110V-6A (3m conveyor belt)
21a	107-01870	Control box model -110V-7A (4.5m conveyor belt)
21b	107-01878	Control box model - 230V-3.5A (4.5m conveyor belt)
22	107-00626	Capacitor 50mf (110v -3m)
22a	107-01891	Capacitor 60mf (110V - 4.5m)
22b	107-04184	Capacitor 25mf (230V)
23	107-00683	Bridge switch box
24	107-00543	Decal user instructions
26	107-00446	Drive roller 110V 0,37kW (3m conveyor belt)
26a	107-00447	Drive roller 110V 0,50kW (4,5m conveyor belt)
26b	107-00850	Drive roller 230V 0,50kW (4,5m conveyor belt)
27	107-01842	Emergency switch + button (3m conveyor belt)
27a	107-01809	Emergency switch + button (4,5m conveyor belt)
28	107-01810	Start button on control box
29	107-01934	Fuse 6.0 A - (110v - 3m conveyor belt)
29a	107-01091	Fuse 7.5 A - (110v - 4,5m conveyor belt)
29b	107-01932	Fuse 3.5 A - (230v - 4,5m conveyor belt)
30	107-00610	Fuse cover
31	107-01811	6-pole outlet control box
32	107-01812	End plug - six-pole
not shown	107-00808	3m conveyor belt moulding
not shown	107-00814	4,5m conveyor belt moulding
33	107-00810	Large hopper (TBH01)
34	107-00786	Side rubber large hopper
35	107-00785	Back rubber small hopper
36	107-00856	Small hopper (TBH02)
37	107-00843	Back rubber small hopper
38	107-00844	Side rubber small hopper
39	107-00862	Wheel set (TBW01)
40	107-00860	Conveyor Support Frame (TBS01)
41	107-01880	Power cable 110V
41a	107-01813	Power cable 230V
42	107-01814	Link cord (TBC01)
43	107-01093	Relay 230v - S3

GENERAL ASSEMBLY PLAN CONVEYOR BELT

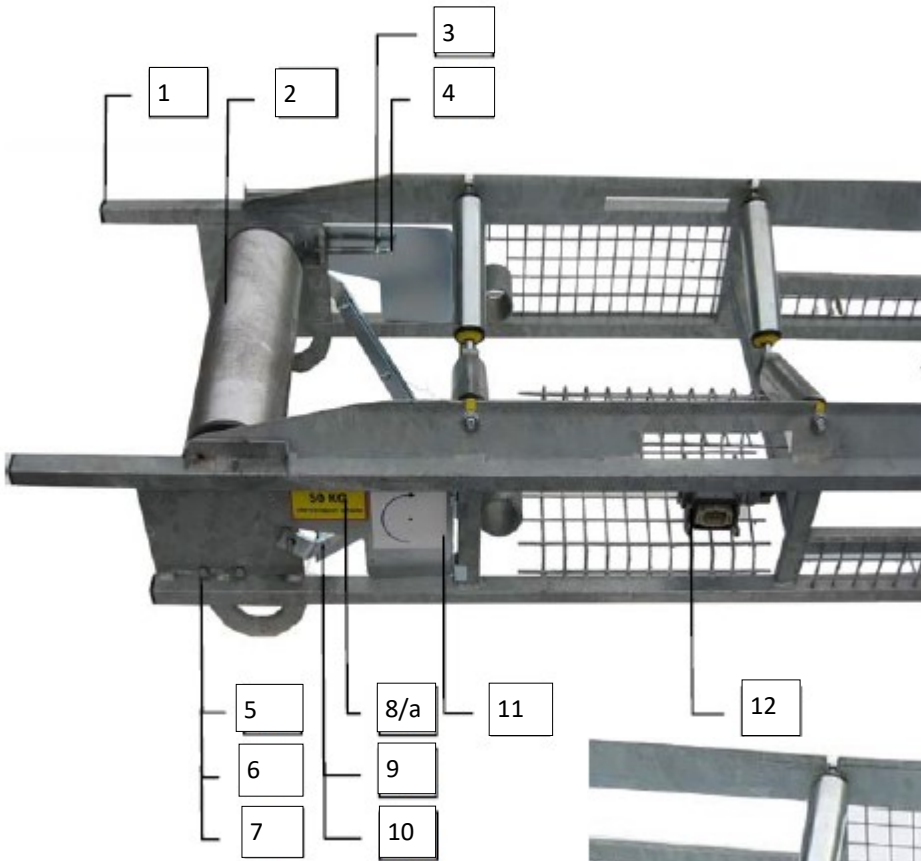

RETURN ROLLER SIDE
CONVEYOR BELT

MIDDLE
CONVEYOR
BELT

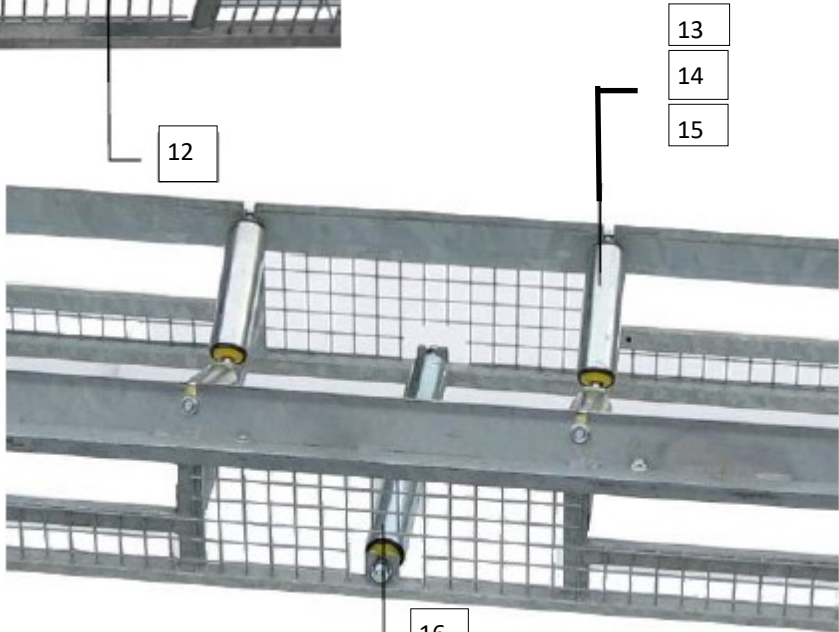

16
15
14

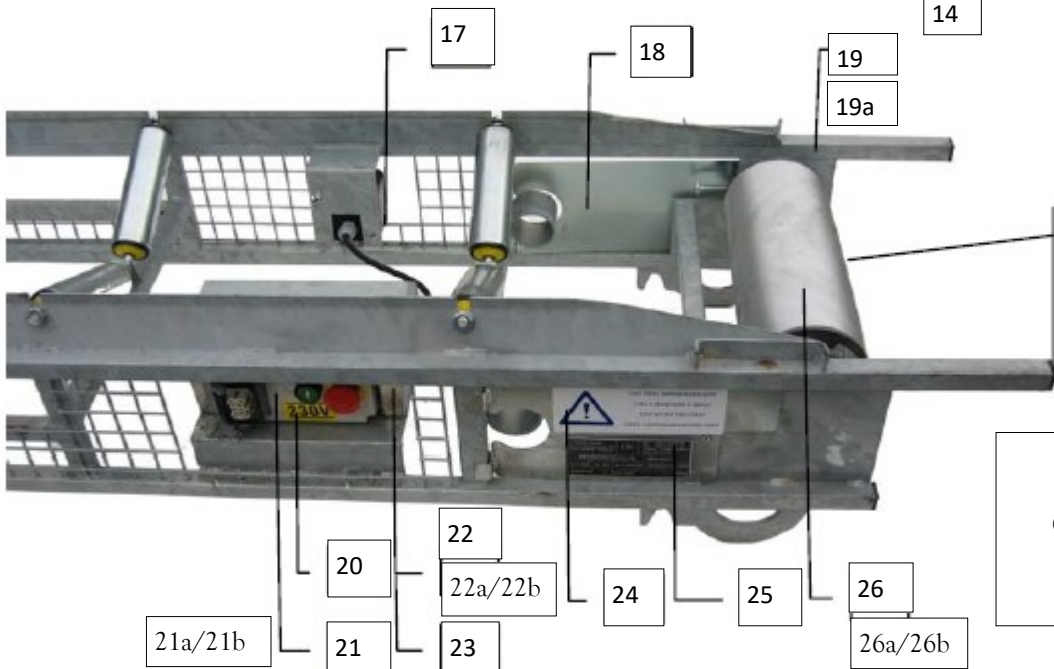

MOTOR SIDE
CONVEYOR BELT

SWITCHBOX DIAGRAM

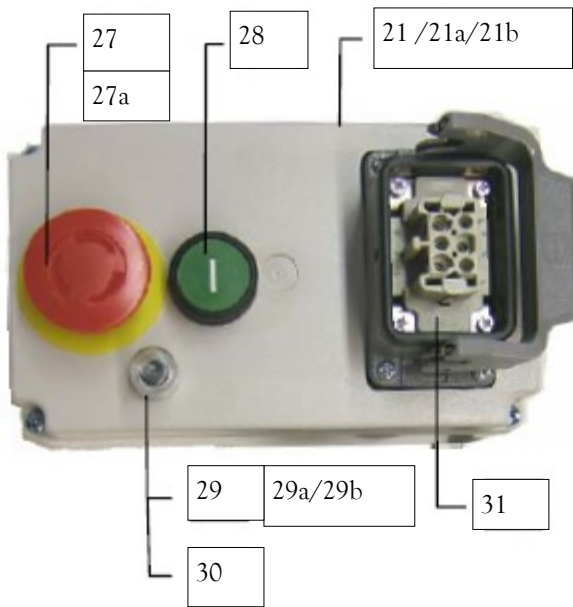

ACCESSORIES DIAGRAM

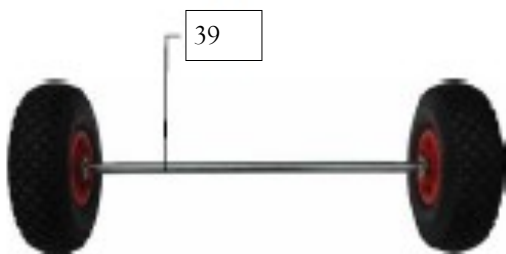
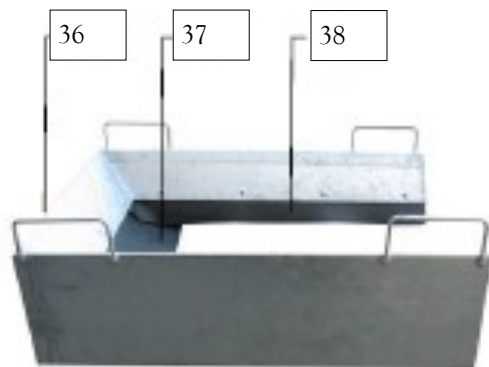
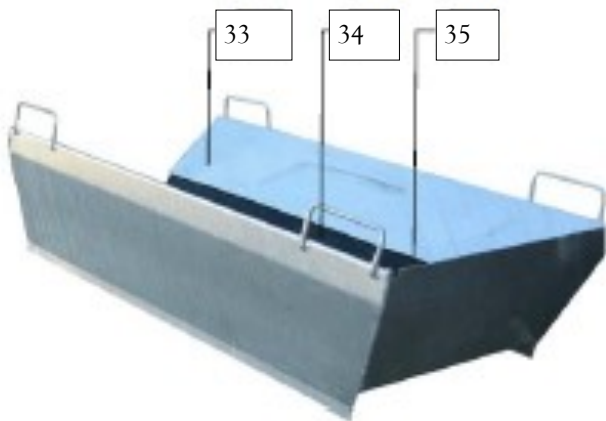

ELECTRICAL CIRCUIT DIAGRAM

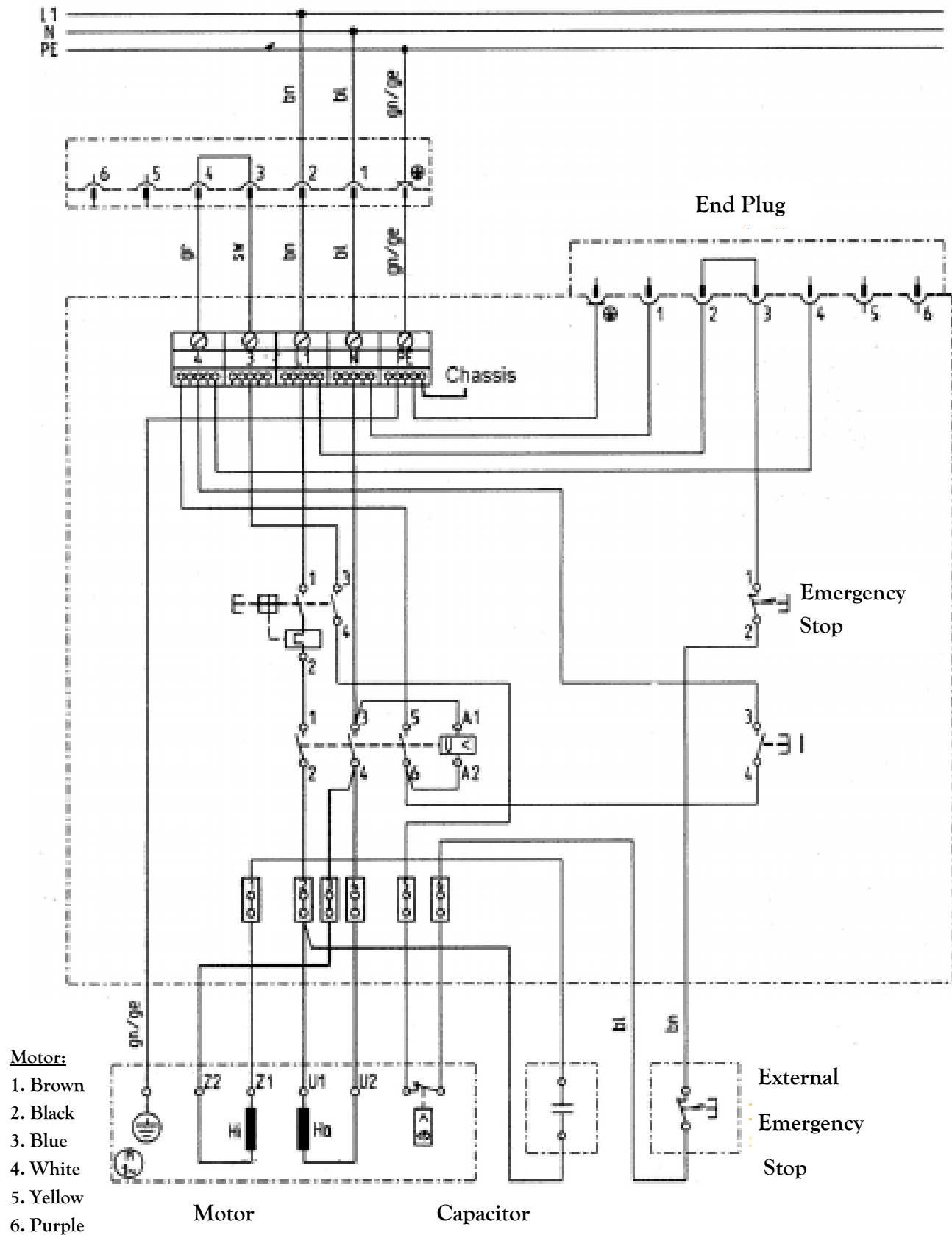

EMERGENCY STOP DIAGRAM

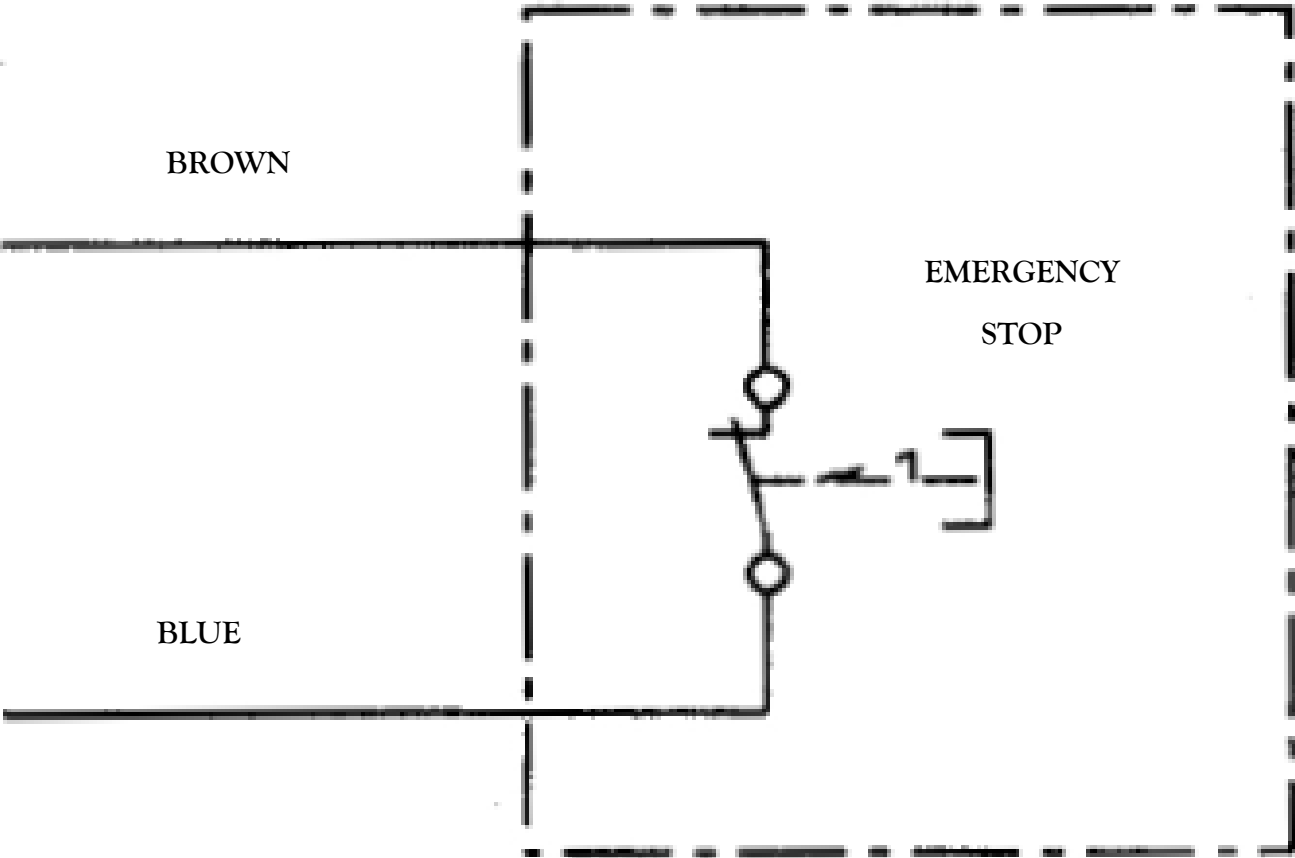

OWNER NOTES

WARRANTY REGISTRATION FORM

Your new TUFFBELT is warranted to the original purchaser for a period of one-year (12 months) from the original date of purchase.

The TUFFBELT warranty is against defects in design, materials and workmanship.

The following are not covered under the TUFFBELT warranty:

1. Damage caused by abuse, misuse, dropping or other similar damage caused by or as a result of failure to follow assembly, operation or user maintenance instructions.
2. Alterations, additions or repairs carried out by persons other than Tufftruk or their recognised agents.
3. Transportation or shipment costs to and from TUFFBELT or their recognised agents, for repair or assessment against a warranty claim, on any machine.
4. Materials and /or labour costs to renew repair or replace components due to fair wear and tear the following components are not covered by warranty.

TUFFBELT and/or their recognised agents, directors, employees or insurers will not be held liable for consequential or other damages, losses or expenses in connection with or by reason of or the inability to use the machine for any purpose

Warranty Claims

All warranty claims should firstly be directed to the point of purchase: your TUFFBELT reseller / distributor

Keep a record of the warranty form for your records

For warranty claims: Tel +44 (0) 1298 84687 or Email; sales@tufftruk.co.uk

Any warranty issues please do contact your place of purchase.

To Register your Warranty please complete the warranty form and post to

TUFFTRUK LTD
UNIT 5, PRINCE STREET BUSINESS PARK
PRINCE STREET, LEEK, STAFFORDSHIRE, ST13 6DB
Tel + 44 (0) 1298 84687 E-mail sales@tufftruk.co.uk

Alternatively visit the website www.truxta.com/service and register warranty online

Alternatively scan / photocopy and email the completed warranty form to sales@tufftruk.co.uk

For your records, please complete this warranty registration in operator manual.

DATE OF PURCHASE

PLACE OF PURCHASE/ COMPANY

CUSTOMER NAME

ADDRESS

MACHINE MODEL NO

SERIAL NO OF MACHINE

Your local TRUXTA Dealer



Tufftruk Limited

Unit 5, Prince Street Business Park

Prince Street, Leek

Staffordshire ST13 6DB

Tel +44 (0) 1298 84687

sales@tufftruk.co.uk

Auckland Head Office
6-10 Parkway Drive,
Mairangi Bay, Auckland
Phone: (+64) 09 443 2436
Email: sales@yrco.co.nz

Auckland, Mt Wellington
20L Sylvia Park Road,
Mt Wellington, Auckland
Phone: (+64) 09 553 5470
Email: salesmtwell@yrco.co.nz
(Open January 2022)

Wellington
8 Broken Hill Road,
Porirua, Wellington
Phone: (+64) 04 212 2456
Email: saleswell@yrco.co.nz

Christchurch
20 Nga Mahi Road,
Sockburn, Christchurch
Phone: (+64) 03 341 6923
Email: saleschch@yrco.co.nz

YR Youngman
Richardson