

Language: English
Geographic Region: Not USA
Serial Number Range: SN TTA3875-TTA5000



TEREX®

PT30

**Operation and Maintenance
Manual**

This manual is complements of
TrackLoaderParts.com

The world's best source for Terex parts.



Introduction	2
Safety	5
Technical Data.....	31
Machine Description / Controls.....	37
Operation	43
Transportation	53
Maintenance	59
Service Log	79

1 INTRODUCTION

1.1 Product Identification (PIN)

The machine PIN is located on the identification plate, behind and to the left of the operator seat.

Please state the model of the machine and PIN when making inquiries in regards to parts, service, or warranty.

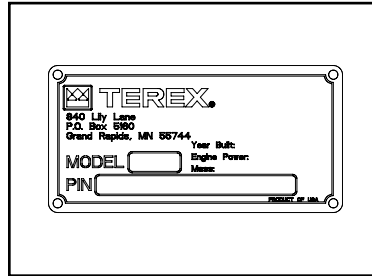

1.2 Introduction

Thank you for purchasing a Terex Rubber Track Loader. We are confident that the machine you have chosen will provide excellent performance and efficient operation.

The information contained in this manual is intended to provide the operator with all necessary information for the proper use of the machine.

It is imperative that this manual be provided to the end user at the time of purchase, prior to operation and kept with the machine at all times. If lost or damaged, contact your dealer immediately to obtain a replacement prior to resuming operation.

It is very important that the operator read and understand the information in this manual prior to operating the machine or performing maintenance or service.

During operation, it is very important that the operator obey the instructions in this manual to ensure safe and efficient operation.

Should you need clarification or further explanation of the topics in this manual, please contact your dealer immediately for assistance.

Information describing special equipment or attachments and their operation are not included in this manual.



1.3 Safety Alert System

This symbol means: **Attention! Be alert! Your safety is involved!**

The safety alert symbol is used to alert you to potential personal injury hazards. Obey all safety messages that follow this symbol to avoid possible injury or death.

1.4 Intended Use

The machine with standard dirt bucket is intended to be used solely for work consistent with its design. Such work involves loosening, collecting, transporting, and distributing soil, rock, or similar materials as well as loading these materials onto trucks, conveyors, or other methods of transport.

After installation of additionally approved special working attachments, the equipment can be used for corresponding applications.

The operator must follow the enclosed operating instructions for any externally supplied components or attachments.

Any use varying from that described here or any lack of adherence to the operating instructions, maintenance procedures, or replacement intervals described in this manual shall be regarded as unintended or improper use. The supplier cannot be held responsible for any damage resulting from improper use. This risk is borne solely by the user.

1.5 Copyright

This manual is intended for use by personnel responsible for operation, maintenance, repair, and supervision activities involving the machine described within.

This manual is copyrighted. It shall not, either in whole or in part, be reproduced, transmitted, or used for the purpose of competition without our prior written consent.

1.6 Warranty

Your Terex PT-30 is warranted under the Terex Rubber Track Loader and Utility Vehicle Standard Limited New Product Warranty ("Warranty"). A copy of the Warranty certificate is included with this manual and is also available from your Authorized Terex Distributor.

2.1 Safety Alert Symbol	7
2.2 Pictograms	8
2.3 Safety Symbols	11
2.4 Safety Signs	14
2.5 General Notes	16
2.6 Personal Protection Equipment	17
2.7 Danger Zone	17
2.8 Operation	18
2.9 Stability	19
2.10 Transport of Persons	19
2.11 Fire Prevention	20
2.12 Crush / Burn Avoidance	21
2.13 Placing Into Operation	22
2.14 Starting the Machine	22
2.15 Jobsite Safety	23
2.16 Parking the Machine	24
2.17 Towing / Retrieving	24
2.18 Transporting	25
2.19 Maintenance	26
2.20 Battery	28
2.21 Hydraulic Lines / Hoses	29



2.1 Safety Alert Symbol

This symbol means: **Attention! Be alert! Your safety is involved!**

The safety alert symbol is used to alert you to potential personal injury hazards. Obey all safety messages that follow this symbol to avoid possible injury or death.

This symbol is used as an attention-getting device throughout this manual as well as on decals and labels fixed to the machinery to assist in potential hazard recognition and prevention.

Property or equipment damage warnings in this publication are identified by the signal word "NOTICE".











NOTICE









"NOTICE" Indicates a hazardous situation which, if not avoided, could result in property or equipment damage.

The word "Note" is used throughout this manual to draw your attention to specific topics or to supplement the information provided in that section.

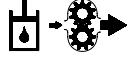

2 SAFETY

2.2 Pictograms













Symbol	Description
	Engine Start
	Engine Stop
	Engine Pre-heat
	Battery
	Engine Speed: Fast Wiper Speed: High
	Engine Speed: Slow Wiper Speed: Low
	Unlock
	Lock
	Windshield Washer
	Windshield Wiper

Symbol	Description
	Beacon Light
	Tie Down
	Auxiliary Hydraulics
	Auxiliary Hydraulics (high flow) (Not Available on PT-30)
	Power Quick Attach (unlock) (Not Available on PT-30)
	Power Quick Attach (lock) (Not Available on PT-30)
	Air Conditioning (Not Available on PT-30)
	Oil Pressure
	Engine Oil Temperature
	Hydraulic Oil Temperature













2 SAFETY



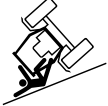





Symbol	Description
 A line drawing of a work light fixture with a lens and a mounting bracket.	Work Lights
 A circle containing the letter 'P', which is a standard symbol for parking brake.	Parking Brake
 A solid black icon of a fan with four curved blades.	Fan

2.3 Safety Symbols

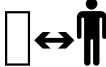
Hazard	Avoidance	Description
		<p>Hazard: Injection</p> <p>Avoidance: Use a piece of cardboard or paper to search for leaks. Do not use your hand. Fluid injected into the skin must be surgically removed within a few hours by a doctor familiar with this type of injury or gangrene will result.</p>
		<p>Hazard: Corrosive</p> <p>Avoidance: Read and understand the operator's manual before using or maintaining the machine.</p>
		<p>Hazard: Entanglement</p> <p>Avoidance: Stop the engine before servicing the machine.</p>
		<p>Hazard: Explosion-Pressurized Air / Fluid</p> <p>Avoidance: Allow engine to cool thoroughly prior to performing service.</p>
	  	<p>Hazard: Battery explosion</p> <p>Avoidance: No Smoking! Keep sparks or flame away from the battery. Read and understand the operator's manual before using or maintaining the machine.</p>

2 SAFETY

Hazard	Avoidance	Description
		<p>Hazard: Falling</p> <p>Avoidance: Use three points of contact when entering or exiting the machine.</p>
		<p>Hazard: Falling (no riders)</p> <p>Avoidance: Do not allow riders in or on the machine at any time.</p>
		<p>Hazard: Burn</p> <p>Avoidance: Allow surfaces to cool before servicing.</p>
		<p>Hazard: Ejection / Roll Over</p> <p>Avoidance: Fasten safety belt.</p>
		<p>Hazard: Rotating Parts can cause personal injury.</p> <p>Avoidance: Stop the engine before servicing the machine.</p>
		<p>Hazard: Instability / Rollover</p> <p>Avoidance: Carry loads low, keep heaviest end of machine uphill at all times while operating on inclines.</p>

Hazard	Avoidance	Description
		<p>Hazard: Falling (from bucket or attachment)</p> <p>Avoidance: Keep away. Do not use the bucket or attachment as a work platform.</p>
		<p>Hazard: Run Over / Crush</p> <p>Avoidance: Keep away from the machine while it is in operation.</p>
		<p>Hazard: Loader Crush</p> <p>Avoidance: Keep out from under unsupported lift arms. Install lift arm brace prior to going beneath the lift arms.</p>
		<p>Hazard: Fire / Overheat</p> <p>Avoidance: Read and understand the operator's manual before using or maintaining the machine.</p>
		<p>Hazard: Attention, Your safety is involved!</p> <p>Avoidance: Read and understand the operator's manual before using or maintaining the machine.</p>

2 SAFETY

2.4 Safety Signs

The safety signs are located in/on the machine as indicated. (Descriptions of the symbols are provided in section 2.3)

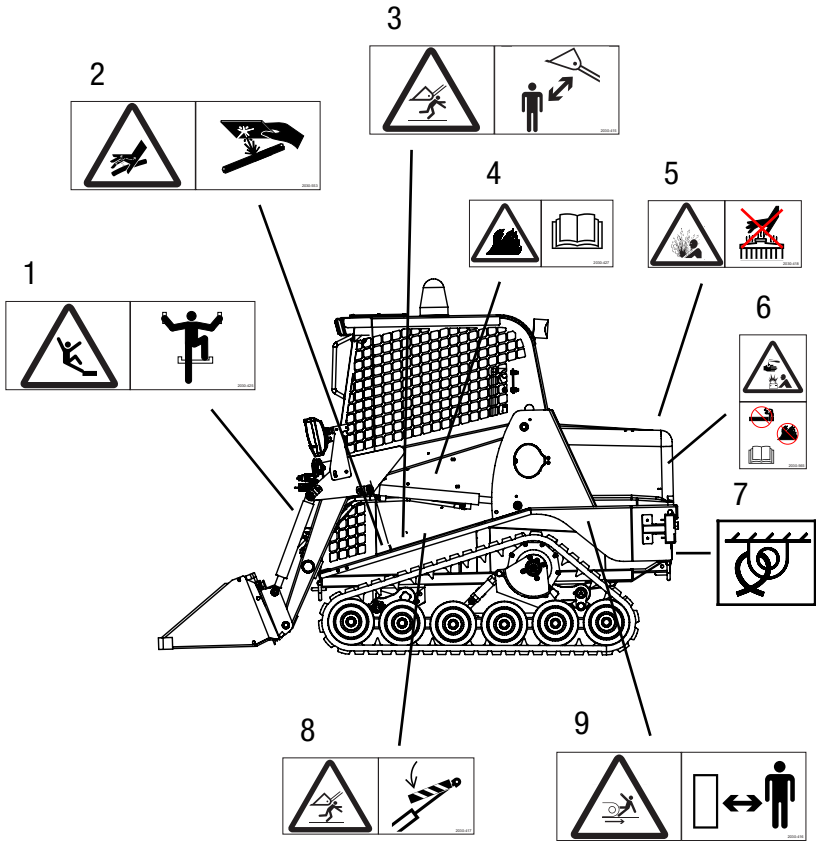

Key

1. Falling hazard
2. Skin (oil) injection hazard
3. Crushing hazard (lift arms)
4. Fire hazard (read manual) (inside cab)
5. Pressurized fluid/gas hazard (engine area)
6. Battery acid/explosion hazard (read operator's manual) (engine area)
7. Tie down location
8. Crushing hazard (lift arm brace)
9. Run over hazard

Note:

If any of the safety signs shown in this section are missing or damaged, contact your dealer to obtain a replacement.

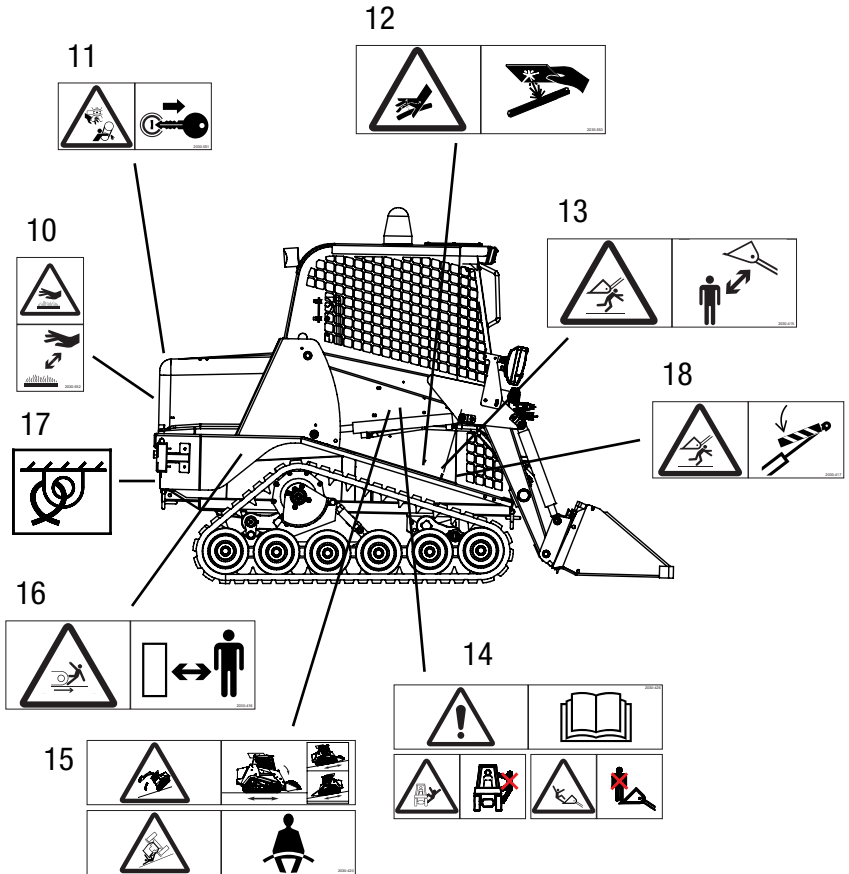

Key (continued)

10. Hot surfaces hazard (engine area)
11. Belt/fan entanglement hazard (engine area)
12. Skin (oil) injection hazard
13. Crushing Hazard (Lift arms)
14. Read operator's manual/ Falling hazards (inside cab)
15. Rollover/Ejection hazard (inside cab)
16. Crushing (run over) hazard
17. Tie down location
18. Crushing hazard (lift arm brace)

2 SAFETY



2.5 General Safety Notes

- Read and understand all safety signs and operator's manuals prior to operation.
- Never jump off of the machine. Instead use the hand holds and step designed for entering and exiting the machine. Face the machine and use three points of contact to ensure your safety.
- Do not use any method of operation, inspection, or maintenance that may impair safety.
- This machine is only to be used when properly equipped for the task to be performed and when properly inspected and maintained to ensure safe operation.
- The manufacturer's instructions regarding operation, inspection, maintenance, repair and transportation **must** be followed.
- Never place the machine into operation without having first performed a thorough walk-around inspection and making any necessary repairs or adjustments.
- Safety devices on the machine shall not be deactivated or removed.
- Do not make any changes, additions or conversions to the machine that could have a negative effect on safety without the manufacturer's approval.



2.6 Personal Protection Equipment (PPE)

The machine is designed to accommodate and protect an operator during operation from foreseeable injury **when used as intended and when equipped properly for the task(s) being performed**. Operators should not wear rings, scarves, open jackets, and should ensure that all clothing is tightly secured. Long hair should be restrained. Personal Protective Equipment (PPE) must be worn in the absence of an enclosed cab. In this case PPE would include, but not be limited to, safety glasses. The use of some attachments may require additional PPE, such as hearing protection, hardhat, gloves, and steel-toed shoes. In some applications high visibility/reflective jackets are required.

Personal protection equipment is also recommended when performing maintenance or service on a machine. Always wear appropriate protective equipment for working conditions when working on or around the machine. Loose clothing should not be worn and long hair should be restrained. Wear hard hats, protective face/eyewear, safety shoes and any other equipment necessary to ensure your safety and the safety of others around you as you work.



2.7 Danger Zone

The danger zone encompasses the area around the machine in which persons may be injured by movements of the machine during operation, its attachments, or by falling loads.

Do not position yourself or allow anyone else within this danger zone during machine operation. Keep a safe distance to ensure your safety while the machine is in operation.

If someone enters the danger zone, the operator must stop all work and give a warning signal to the person who may be in danger to leave the danger zone. Work should not resume until all persons have vacated the danger zone.

To minimize the possibility of a crushing hazard, a sufficient safety distance (min. 0.5 m (1.6 ft)) must be kept from solid objects, e. g. buildings, slopes, scaffolding, other machines, etc. If that distance cannot be kept, fence off the area between solid construction elements and the working range of the machine.

If conditions are such that the machine operator's view of the driving and working zone is restricted, he must be guided or the driving and working zone must be secured by means of a solid barricade.

2 SAFETY



2.8 Operation

Earth moving machines are only to be operated and serviced by individuals who

- are physically and mentally able to operate and / or service the machine in a safe manner.
- have been instructed in the proper operation or maintenance of the machine and have demonstrated competence in these areas.
- can be trusted to perform their assigned duties in a safe and reliable manner.
- are of the legal minimum age for performing such duties.

It is the responsibility of the operator to

- inspect the machine prior to operation and perform any necessary checks, adjustments or repairs to ensure safe operation.
- read and understand the instructions in this manual prior to operation and to follow them during operation.
- familiarize him/herself with the local worksite conditions and immediately remedy any fault that may compromise safety.
- use the machine in accordance with the appropriate local job site organization system to ensure safe coordination with other machines, vehicles, and people on the job site.

Investigate any work site prior to operation to determine whether any special hazards exist. Take necessary measures to eliminate or reduce any hazard.

Do not operate the machine in unsafe conditions including, but not limited to: near overhead electric lines, in enclosed areas without proper ventilation, in contaminated areas without necessary safety equipment and personnel.



2.9 Stability

The machine must always be operated with caution in order to maximize machine stability and guard against the possibility of a rollover.

- Travel only at speeds appropriate for the local conditions.
- Do not exceed the operating capacity of the machine.
- Never operate the PT-30 on an incline in excess of 10°.
- Do not make sudden changes in direction, move slowly, and always carry loads low to maximize machine stability.
- Always keep the heaviest end of the machine facing uphill when travelling on an incline.
- When turning on an incline, back down the hill while slowly turning until the machine is pointed in the desired direction. Then proceed forward.
- When operating on any surface other than firm and level ground, use extra caution. Decrease work speeds, limit load size and make any other necessary adjustments to maximize your safety and that of others in the work area.



2.10 Transporting Persons

- The machine must not be used to transport persons.

2 SAFETY



2.11 Fire Prevention

Rubber track loaders have components that operate at high temperatures. It is important to observe all inspection, operation and maintenance guidelines to minimize the possibility of fire.

- Turn the engine off when refueling.
- When refueling or charging the battery, do not smoke or allow open flame near the machine.
- Always start the engine according to the procedure in the operating instructions.
- Inspect and clean the radiator/oil cooler, engine compartment, exhaust system and other areas where there may be hot or rotating parts **daily**. In some work environments, flammable debris including but not limited to: leaves, straw, wood particles (dust), and similar items can accumulate in these areas and can lead to fire.
- Check the electrical system regularly. Have any faults such as loose connections, burnt fuses, glow lamps and damaged wiring repaired by professional personnel immediately.
- Regularly check all lines, hoses and threaded couplings for leaks and damage. Repair leaks immediately and replace any defective parts. Oil leaks can easily lead to a fire. **NEVER use bare hands to check for hydraulic leaks!** Pressurized fluid (oil) can penetrate skin and cause gangrene. If injection occurs, seek medical attention immediately!
- Do not use any starting aids containing ether to start diesel engines with pre-heat systems! Use of starting aids of this nature can cause an EXPLOSION!
- Familiarize yourself with the location of any fire extinguishers in/on the machine and how to use them as well as local options for reporting and fighting fires should one occur.



2.12 Crush and Burn Avoidance

- Do not work under the lift arms unless they are resting safely on the ground or supported by the lift arm brace.
- Do not use any restraining devices such as cables or chains that are damaged or do not have sufficient carrying capacity. Always wear safety gloves when working with wire cables.
- Never align holes with your fingers when working on the machine. Instead use a suitable mandrel.
- Keep yourself and all objects that could be drawn into the fan at a safe distance while the engine is running. The fan may deflect these objects away or destroy them and would likely be damaged by the objects.
- The entire cooling system is hot and under pressure when it is at or near operating temperature. Avoid touching parts that carry coolant to avoid the possibility of burns.
- Allow the machine to cool thoroughly prior to touching or removing the cooling system cap. Once cool, loosen the cover slowly to bleed off any excess pressure.
- The engine and hydraulic oil are hot when at or near operating temperature. Avoid skin contact with hot oil or parts carrying oil.
- Wear safety goggles and protective gloves when you are working with the battery. Keep sparks and open flames away from the work area.
- Before performing any work in the engine compartment, make sure the locking mechanism is engaged on the hood support strut so that the engine cover cannot close unintentionally.
- Exhaust components are hot when at or near operating temperature. Allow the machine to cool thoroughly prior to touching or performing service work on exhaust components to avoid the possibility of burns.

2 SAFETY



2.13 Placing into Operation

- Every time before placing the machine into operation, perform a thorough walk-around inspection of the machine.
- Check the machine for loose pins, cracks, tears, wear, leaks and deliberate damage.
- Never place a damaged machine into operation.
- Make any necessary repairs immediately, prior to resuming operation.
- Close and lock all hoods and covers, then inspect to make sure all warning signs are in place and legible.
- Make sure all windows and mirrors are clean. Secure door and windows against unintentional movements.
- Make certain no one is working on or under the machine and warn any persons standing nearby that the machine will be placed into operation.
- Prior to placing the machine into operation, adjust the driver's seat, mirrors, and ventilation system settings (if equipped) so you can work in comfort and safety.



2.14 Starting the Machine

- Before starting, check all indicator lamps and instruments to make certain they are working properly.
- Start the engine in the manner described in the operating instructions.
- Only allow the engine to run in enclosed rooms if there is adequate ventilation. If necessary, open doors and windows to ensure a proper supply of fresh air.
- Bring the engine and hydraulic oil up to operating temperature. Low oil temperatures can cause the control system to respond sluggishly.
- Move the machine carefully to open ground and then check the functionality of the lift arm and drive controls as well as the signal and lighting equipment.



2.15 Jobsite Safety

- Before beginning work, become acquainted with any special features or requirements of the work site. These may include, for example, obstructions in the work area, the carrying capacity of the ground and requirements to close the work site off from public traffic.
- Always maintain an adequate safety distance to overhanging features, edges, embankments and unsafe surfaces.
- Be especially cautious if visibility is poor, light conditions are low or soil conditions vary.
- Become acquainted with the location of supply lines at the work site and be especially careful when working close to them. Consult appropriate local authorities for necessary information regarding any such lines prior to commencing work.
- Keep the machine at an adequate distance from overhead electrical lines. When working in the vicinity of overhead electrical lines, do not come close to the lines with the machine. **Injury or death may result!** If possible, have the current turned off or line re-routed prior to beginning work.
- In the event electrical current jumps from a line to the machine, follow these rules:
 - do not perform any movements with the machine
 - do not leave the cab
 - warn persons outside not to approach or touch the machine
 - have the current turned off immediately
- Always turn on the appropriate lighting when visibility is poor or light conditions are low.
- Do not allow any passengers in or on the machine.
- Stay seated with the safety belt fastened while working.
- Report any operating faults immediately. Make sure any necessary repairs are performed prior to resuming operation.
- Never leave the machine unattended with the engine running.

2 SAFETY



2.16 Parking the Machine

- If possible, turn the machine off only on an even and solid surface.
- Lower the lift arms to the frame stop and rest the bucket on the ground.
- Turn off the engine as described in the operating instructions.
- Close the machine doors and windows (if equipped), remove the key to secure the machine against unauthorized use.



2.17 Towing/Retrieving the Machine (see note below)

- Always observe the correct procedure as described in the operating instructions.
- The machine should be towed only in exceptional cases, for example to bring the machine away from an endangered place for repair.
- Check all trailing and drawing devices for their safety when pulling or towing.
- Towing equipment such as ropes, rods, etc., must be of the correct capacity and must use at least two of the d-rings (if equipped, see note) on the front or rear of the machine on the chassis.
- Pull the rope taut slowly and carefully. A sudden jerk can cause a sagging rope or cable to tear or snap.

Note: Some machines may not be equipped with D-rings at the corners of the chassis. **If your machine is not equipped with D-rings, the machine may not be towed or retrieved by pulling or dragging the machine.** It must instead be lifted from above through the use of the optional lift kit, or from underneath, supporting the center portion of both of the torsion axles as the machine is placed on a trailer for transport. It can then be properly secured and transported to a suitable location for repair.



2.18 Transporting the Machine

- Use only suitable transport and lifting equipment with sufficient carrying capacity.
- Load the machine on firm and level ground.
- Before driving onto the ramps, clean them and the machine tracks of any materials that may cause slippage (snow, ice, sludge, etc.).
- Properly align the machine with the loading ramp.
- Have a guide give the machine operator any necessary signs to maximize safety during loading.
- Move carefully onto the ramps and transport vehicle.
- Before you leave the machine, relieve all residual pressure by making sure all operating levers and switches are in their neutral positions. Remove the ignition key.
- Secure the door, windows and hood on the machine.
- Secure the machine and any other items against slipping with chains, ropes of the proper capacity.
- Before departure, investigate the route to be taken, especially in regard to limits for width, height and weight.
- Pay close attention when driving under electrical lines, bridges, or through tunnels.
- Use the same caution when unloading as for loading. Remove all cables/chains. Start the engine as described in the operating instructions. Carefully drive down the ramp from the transport vehicle using a guide if necessary to direct movement.
- When lifting attachments or components, use caution. Attach straps or chains securely and in such a way that they evenly distribute the weight of the item to be lifted, ensuring a balanced load. Stay clear of expected travel path.

2 SAFETY



2.19 Maintenance

- Do not perform any maintenance work or repair task that you do not understand thoroughly.
- Park the machine on firm and level ground in a well lit and well ventilated area suitable for performing service or maintenance work.
- Disconnect the battery and remove the ignition key from the ignition before beginning work on a machine. Place a **Do Not Operate** tag across the opening of the cab to alert any operator that maintenance is in progress.
- Do not work on or under any machine that is supported only by a hydraulic jack or hoist. Always use mechanical supports to ensure that the machine will not fall. Terex jack stands work well to support the machine while performing maintenance or repair work.
- Make sure the work area around the machine is safe and make yourself aware of any hazardous conditions that may exist. If the engine needs to be started inside an enclosure, make sure that the engine's exhaust is properly vented.
- Be sure all protective devices including guards and shields are properly installed and functioning correctly before beginning any service task. If a guard or shield must be removed to perform the maintenance work, use extra caution.
- Always use the appropriate tools for the work to be performed. Tools should be in good condition and you should understand how to use them properly before performing any task.
- When replacing parts or fasteners, use parts of equivalent quality, grade and/or size. Use original Terex components to ensure the proper form, fit, and function of replacement parts.
- When performing maintenance work, always wear appropriate safety clothing for the task to be performed. Some examples might include: safety shoes, safety goggles and safety gloves.
- Relieve hydraulic system pressure by relaxing all hydraulic actuators prior to attempting any hydraulic maintenance or repair.

- When performing service that requires the lift arms to be in the raised position, always utilize the lift arm brace.
- If safety equipment needs to be dismantled to fit equipment or perform maintenance or repairs, it must be reattached and tested immediately after the maintenance and repair jobs are completed.
- Clean the machine prior to beginning work. Clean especially the connections and screw couplings of oil, fuel and upkeep materials at the beginning of the maintenance/repair job.
- Do not use flammable liquids to clean the machine.
- Perform tasks on the machine that involve welding or grinding only if approved by Terex. Clean the machine and the work area of dust and any combustible materials before welding or grinding to avoid fire or explosion.
- Before cleaning the machine with water or steam jets (high pressure cleaner) or other cleaning agents, cover or seal over all openings in which water, steam or cleaning agents should not penetrate for safety and/or functional reasons. Electrical motors, switch panels and plug connections are especially subject to damage. Before cleaning, inspect all fuel, engine oil and hydraulic oil lines for leaks, loose connections, rubbed spots and damage. Repair or replace any damaged components immediately.
- When working with oils, greases and other chemical substances, observe all safety requirements that apply to the product in question.
- Ensure that fuels, lubricants and coolants as well as replaced parts are disposed of in an environmentally proper manner.
- Proceed carefully when working with hot lubricants, coolants and fuels (danger of burns and scalding).

2 SAFETY

- Do not attempt to lift heavy parts. Use work aids with sufficient carrying capacity designed for that purpose. Fasten and secure individual parts and large assemblies carefully on lifting equipment to minimize the possibility of objects falling. Use only suitable lifting equipment with no technical defects. Do not work under suspended loads.
- Use only climbing aids and work platforms that meet safety requirements for assembly tasks above body height. Do not use machine parts as climbing aids if they were not designed for that purpose.
- If working at significant height, use a safety harness of the proper style and capacity to prevent falls. Keep all grips, steps, platforms, ladders, etc. free of dirt, snow and ice.



2.20 Battery (corrosive)

- Use caution, wear face shield, safety gloves, and any other appropriate safety equipment when working near or with the battery. The battery contains acid and should be handled with care.
- **DO NOT** smoke or allow open flame or sparks near the battery. Explosion could result.



2.21 Hydraulic Hoses/Lines

- Repairs to hydraulic hoses and hydraulic hose lines are forbidden! These repairs must be performed by trained personnel.
- All hoses, hose lines and screw connections must be checked regularly, at least once a year, for leaks and externally visible damage! Replace any damaged parts immediately! Oil spraying out can cause injuries and burns.
- Even if they are stored properly and subject to proper loads, hoses and hose lines are subject to natural aging. Their service life is therefore limited.

Improper storage, mechanical damage and impermissible load are the most frequent causes of failure.

The usage period of a hose line should not exceed 6 years, including a storage time of no more than 2 years (note manufacturer's date on the hoses).

Use in the limit zone of permissible load may reduce the duration of the usage period (for example high temperatures, multi-shift operation).

- Hoses and hose lines must be replaced if any of the following criteria are encountered during inspections:
 - damage to the outer hose up to the insert (for example worn spots, cuts and tears)
 - embrittlement of the outer layer (formation of cracks in the hose material)
 - deformation when under pressure, without pressure or when bending which differ from the original shape of the hose or hose line, for example separation of layers, formation of bubbles or leaks
 - failure to observe requirements of installation
 - damage or deformation to the hose fitting that reduces the stability of the fitting or the hose/fitting connection
 - hose coming loose from the fitting
 - corrosion of the fitting that reduces functionality and stability
 - exceeding storage times and usage periods
- When replacing hoses and hose lines, use only original spare parts. Install hoses and hose lines properly. Do not confuse connections.

3.1 General Structure	33
3.2 Views	34
3.3 Engine.....	34
3.4 Electrical System.....	34
3.5 Undercarriage	34
3.6 Transmission	35
3.7 Auxiliary Hydraulics	35
3.8 Ground Pressure	35
3.9 Operating Specifications.....	35
3.10 Dimensions and Weights	35
3.11 Service / Refill Capacities.....	36
3.12 Fluid Specifications	36

3.1 General Structure

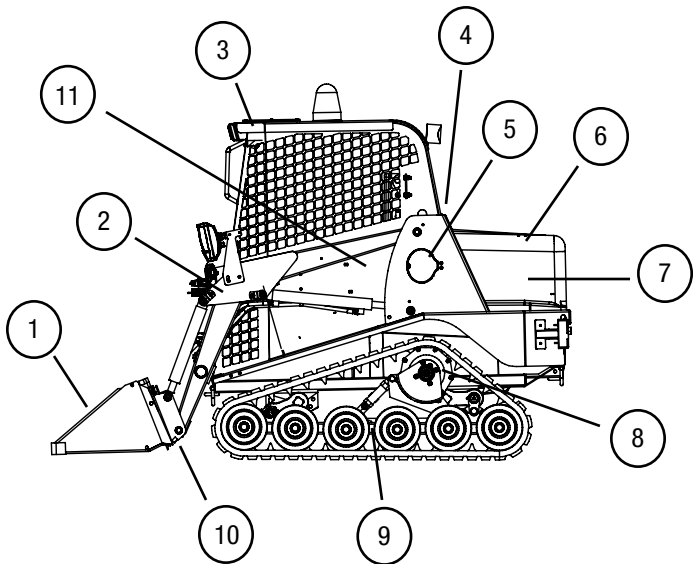

Key

1. Bucket
2. Lift Arm
3. Operator Enclosure (R.O.P.S./F.O.P.S. approved)
4. Hydraulic Oil (fill location)
5. Diesel Fuel (fill location)
6. Hood (engine cover)
7. Engine
8. Drive Motor and Sprocket
9. Undercarriage
10. Quick Attach
11. Product PIN Plate (beside operator seat, inside enclosure)

3 TECHNICAL DATA

3.2 Views

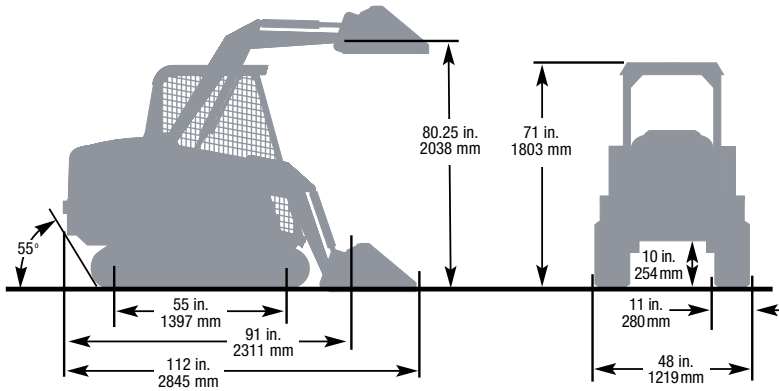

3.3 Engine

Make	Perkins
Type	403-D15
Design	3 cylinders in line
Displacement	1.5L
Power	25.1kW @ 2800 RPM
Admissible inclined Positions	24°
Cooling	Water-antifreeze for all-year operation

3.4 Electrical System

Operating Voltage	12 V
Battery	12V 910 CCA @ 0° C
Alternator	12V 65A
Starter	1.4 kW
Starting Aid	Glow Plugs, w/manual pre-heating relay
Lighting System	Cab mounted work lights

3.5 Undercarriage

Type	Suspended, rubber track w/ screw tension
Travel Speed (max)	9.4 kph
Maximum gradability	10° maximum slope angle
Power Transmission	variable disp. / axial piston motor
Track length, on ground	139.7 cm

3.6 Transmission

Make	Rexroth
Type	AA10VG
Design	Variable displacement / axial piston pump
Displacement	18.0 cc/revolution
Relief Pressure	26,200 kPa

3.7 Auxiliary Hydraulics

Make	Rexroth
Type	9510290004
Design	Gear
Displacement	14.3 cc/revolution
Relief pressure	20,684 kPa
Flow	37.9 lpm @ 2,800 RPM

3.8 Ground pressure

At operating weight	19.2 kPa
At shipping weight	17.2 kPa



3.9 Operating Specifications

Tipping load	726 kg
Operating capacity (50% tip load)	363 kg
Operating capacity (35% tip load)	254 kg

Note: The Maximum Gross Vehicle Weight of the PT-30 is not to exceed 2041kg. This excludes an operator, but does include accessories, attachments and material being carried.

3.10 Dimensions and Weights

Length w/o bucket	2311mm
Length w/bucket	2845mm
Width	1219mm
Height (to top of cab)	1803mm
Ground Clearance	254mm
Weight (operating)	1500kg
Weight (shipping) w/o bucket	1331kg

3 TECHNICAL DATA

3.11 Service / Refill Capacities (approximate)

Fuel tank	37.9l
Hydraulic tank	30.3l
Engine coolant	5.6l
Engine oil including filter	3.8l

3.12 Fluid Specifications

<u>Specifications</u>	<u>Designation</u>	<u>Specification/standard</u>
Fuel	Diesel Fuel	EN590 or ASTM D975 1-D / 2-D
Engine Oil	Engine Oil	SAE 10W-30 (API CH-4)
Engine Coolant	Coolant	Antifreeze/Water (w/SCA additive)
Hydraulic Oil	Hydraulic Oil	Chevron-Rykon MV or equivalent
Lubricating Points	MP Grease	Multi-purpose lithium grease

Alternative Temperature Recommendations

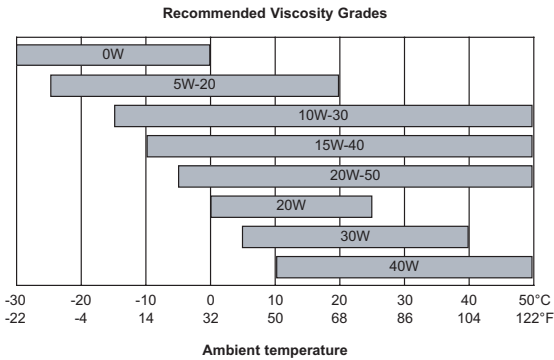

4 MACHINE DESCRIPTION / CONTROLS

4.1 Display Elements.....	39
4.2 Controls.....	40
4.3 Throttle.....	40
4.4 Auxiliary Hydraulics	41

4.1 Display Elements

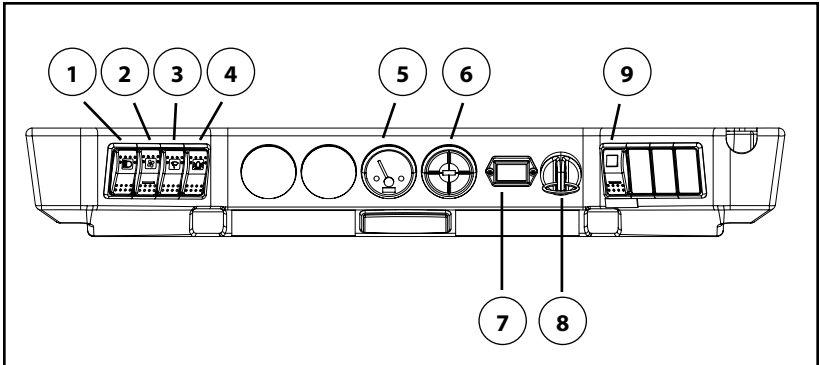

Learn the location and function of these items prior to operation.

Switches

- 1 - Lights, front and rear
- 2 - Heater Fan (optional)
- 3 - Front wiper (optional)
- 4 - Beacon (optional)
- 8 - Ignition, glow plug (pre-heat)
- 9 - Auxiliary Hydraulics

Instruments

- 5 - Fuel Level Gauge
- 6 - Warning Indicators (4-in-one)
- 7 - Hour Meter
- 10 - (not used)
- 11 - Glow Plug Operation Light
- 12 - Oil Pressure Warning Light
- 13 - Battery Voltage Warning Light
- 14 - Hydraulic Oil Temp. Warning Light
- 15 - Engine Temp. Warning Light

If the battery voltage light (13) illuminates, drive the machine to a suitable location and shut the engine off. Diagnose the problem and make any necessary repairs before resuming operation.

The glow plug operation light (11) will illuminate only when the key switch is turned to engine pre-heat, showing normal operation.

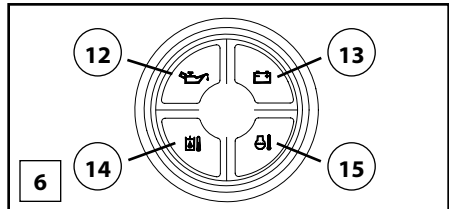
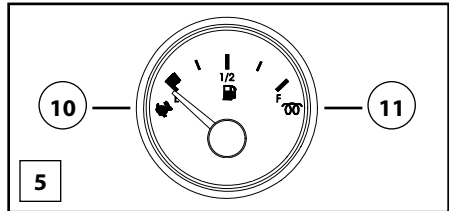

NOTICE

Should the engine temperature gauge read excessive temperatures, or should the oil pressure or hydraulic oil temperature warning lights illuminate during normal operation, shut the machine down immediately (in a safe location). Diagnose the problem and make needed repairs before continuing to operate.

4 MACHINE DESCRIPTION / CONTROLS

4.2 Controls

The PT-30 has two hydraulic pilot joystick controls. The joysticks are used to control machine speed and direction as well as lift arm and bucket functions.

4.2.1 Lift Arm Control

The lift arm joystick is used to control the lift arms, bucket, and to engage the float function. The illustration shows the relationship between joystick movement and resulting lift arm action.

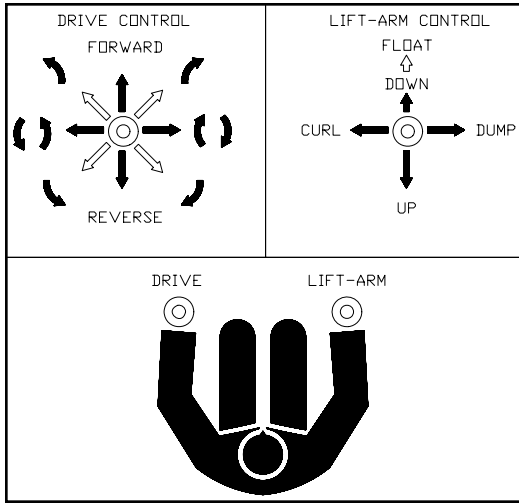

Note: To activate the float function, move the joystick fully forward in a quick motion. The joystick will then be held in detent by the magnet attached to the joystick base. Pull back quickly to disengage the float function.

4.2.2 Drive Control

The drive joystick controls the direction and speed of the machine. The illustration above shows the relationship between joystick movement and resulting machine motion.

4.3 Throttle

The throttle (hand lever) is located to the right of the operator's right leg when seated in the machine. The throttle controls engine rpm.

- Move the lever forward to increase engine RPM.
- Move the lever rearward to decrease engine RPM.
- Select a lower rpm for work that requires delicate operation of the machine.
- Select a higher rpm for faster travel speed or when more power or flow is required for a task.

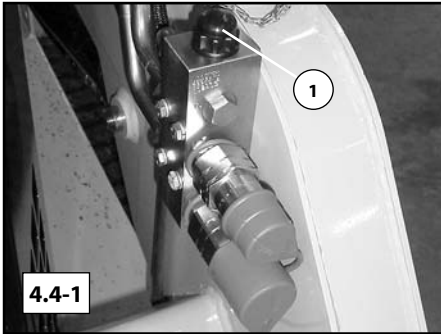

4.4 Auxiliary Hydraulics

The PT-30 models come equipped with an auxiliary hydraulic system designed to power approved hydraulic attachments.

To operate, connect the attachment to the quick couplers (fig. 4.4-1). To release residual pressure in the system, press the button labeled 1 (fig. 4.4-1).

The auxiliary hydraulics can be engaged intermittently or continuously depending on the requirements of the attachment being utilized.

To engage the hydraulic flow intermittently, activate the toggle-type switch on the top of the right joystick (fig. 4.4-2).

To engage the hydraulic flow continuously, activate the 3-position switch on the dash panel, labeled 2 in figure 4.4-3.

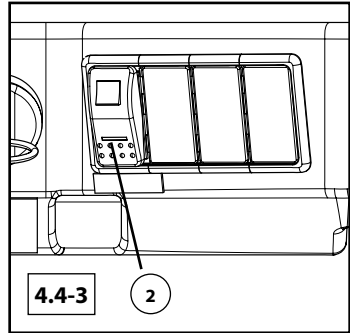

Note: Moving either switch from one position to the other has the effect of reversing flow through the auxiliary hydraulic circuit.

Note: The continuous flow switch must be in its neutral position in order to start the engine.

Note: The continuous flow auxiliary switch has a small orange locking switch that must be disengaged before the switch will activate.

5.1 General Information.....	45
5.2 Pre-Operation Safety Checklist.....	45
5.3 Starting Procedure	46
5.4 Surface Preservation	47
5.5 Filling the Bucket	47
5.6 Grading	48
5.7 Leveling	48
5.8 Loading	49
5.9 Fastening Attachments.....	49
5.10 Unfastening Attachments.....	50
5.11 Operation on Inclines.....	51
5.12 Shut-Down Procedure	51
5.13 Lift Arm Brace	52

5.1 General Information

Operating a Terex Rubber Track Loader is intended to be as safe and simple as possible. This section expands on the machine controls portion of the manual and also covers safe operation procedures to follow while operating.

5.2 Pre-Operation Safety Checklist

Before operating the machine, perform a pre-operation safety check. Inspect the machine for any items that may affect safe operation.

Check to make sure:

1. Engine compartment, chassis and coolers are clean and free of debris.
2. Windows and lights are clean and unobstructed.
3. Tracks are in good condition and are properly tensioned.
4. Fluids are filled to proper levels.
5. Accessory belts are in good condition and properly tensioned.
6. Hydraulic hoses and fittings are in good condition. (no visible signs of wear)



Never use bare hands to check for leaks! Pressurized oil can penetrate skin and cause gangrene. Seek medical attention immediately from a physician familiar with this type of injury!

7. Battery cables are in good condition and properly fastened.
8. Joysticks, auxiliary hydraulic switch are in neutral position.
9. The R.O.P.S./F.O.P.S. approved operator enclosure is not damaged or distorted structurally in any way.
10. The seat belt and lap bar restraint (if equipped) are in good working order.
11. All safety signs are in place and legible on the machine.
12. All control devices are present, appear to be in good condition, and are not damaged in any way.
13. The mirrors (if equipped) are adjusted for proper viewing.
14. You have read and understood the information in this manual in its entirety.

5 OPERATION

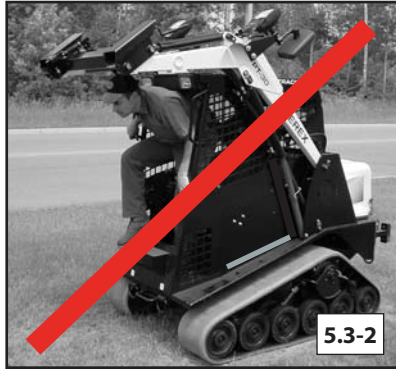

5.3 Starting Procedure

Before starting the engine, perform the pre-operation safety checklist. Once complete, you may proceed by following this procedure:

1. Enter machine with lift arms all the way down. Maintain three points of contact with the machine (fig. 5.3-1).
2. Sit down into the operator's seat, fasten seat belt, then lower lap bar into position.
3. Starting with the throttle in the SLOW (turtle icon) position, push the throttle 1/3 the way open (toward the rabbit icon).
4. Turn the ignition key to the left for 6 seconds to "pre-heat" the engine. While pre-heating, the glow plug operation light will illuminate.
5. Turn the ignition key to the right to start the engine.
6. Let the engine run at low idle for 3 to 5 minutes to warm it.
7. Set the throttle to desired rpm for operation.

Note: The parking brake is automatically engaged when the machine is turned off.



Entering or exiting the vehicle under raised lift arms could result in injury or death. Never allow anyone beneath raised, unsecured lift arms (fig. 5.3-2).

5.4 Surface Preservation

Terex rubber track loaders are designed to produce minimal ground disturbance while operating on finished surfaces like turf, however, care should be taken while operating on these surfaces to prevent blemishes from occurring.

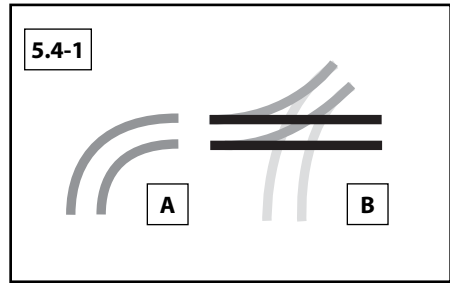

Turning poses the greatest risk of surface disturbance during operation. Moving in a straight line across turf will cause little or no disturbance, whereas tight cornering will most likely cause blemishes.

While working on turf, make gradual turns. (see item A) If space is limited, turn gradually by moving back and forth until facing the desired direction. (see item B)

5.5 Filling The Bucket

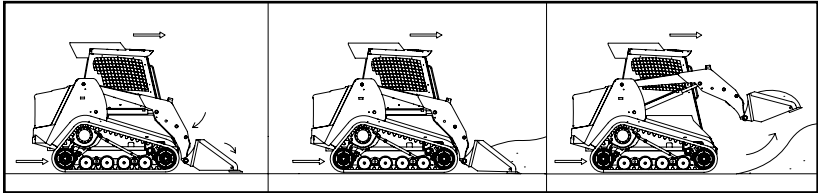

Steps: (see illustration)

1. Lower the lift arms until they rest on the frame.
2. Tilt the bucket slowly forward until the cutting edge engages the ground.
3. Drive the machine forward until the bucket is full of material.
4. Curl the bucket and raise the lift arms simultaneously to break the load free from the pile.
5. Maneuver the machine clear of the pile and then lower the lift arms, keeping the bucket curled upward, to approximately 25-30 cm above the ground for transporting.

5 OPERATION

5.6 Grading

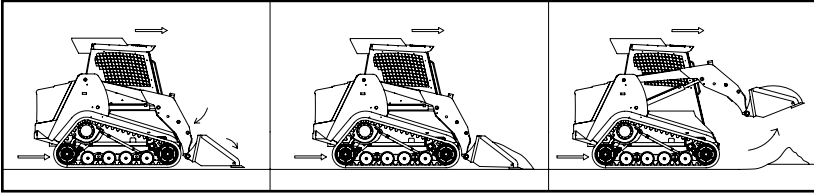

Steps: (see illustration)

1. Lower the lift arms until they rest on the frame.
2. Tilt the bucket slowly forward until the cutting edge engages the ground.
3. Drive the machine forward making slight bucket angle adjustments to vary cut depth as necessary.
4. When full, curl the bucket and raise the lift arms simultaneously. Once clear, lower them to approximately 25-30 cm above the ground for transporting.

NOTICE

Do not push or pull dirt as done in digging, grading, or leveling operations with the bucket tilted fully forward into the "Dump" position. This will stress the bucket cylinders and may damage them.

5.7 Leveling

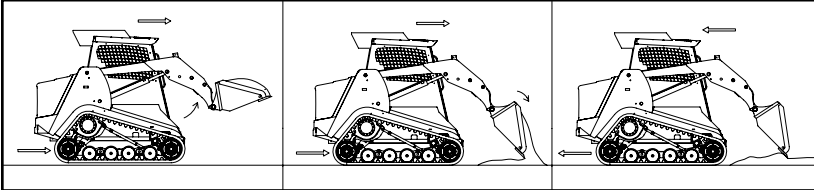

Steps: (see illustration)

1. Moving forward, raise the lift arms as you tilt the bucket slowly forward to evenly spread the material out over the ground.
2. Once the load is released, tilt the bucket forward to an angle 45° or less to the ground.
3. Lower the lift arms until the cutting edge rests on the ground.
4. Engage the float function and back the machine over the material varying bucket angle slightly as necessary to maintain grade.

5.8 Loading

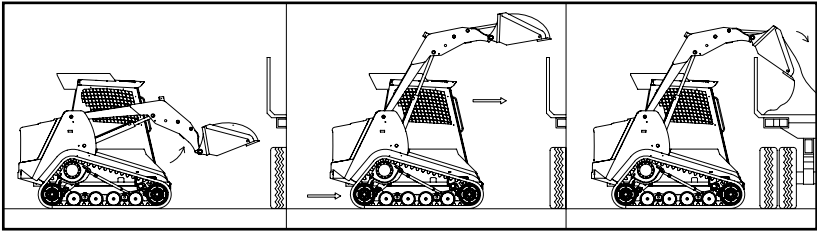

Steps: (see illustration)

1. Raise the lift arms upward, carefully maintaining the bucket angle, until the bottom of the bucket clears the side of the truck bed or trailer.
2. Once clear, drive the machine forward until the pivot point of the bucket clears the bed side.
3. Tilt the bucket forward until all of the material has been released into the bed.

Note: It may be necessary to quickly tilt and curl the bucket while releasing material into the truck bed to evenly distribute the material within the bed.

5.9 Fastening Attachments

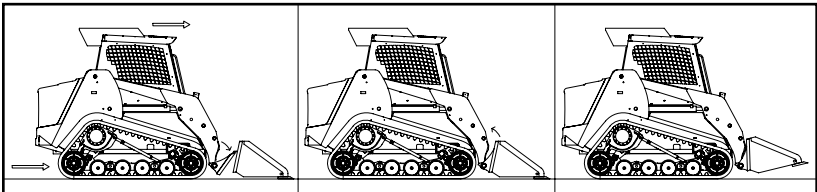

1. Make sure the locking levers on the quick attach mechanism are in their respective unlocked positions. (fig. 5.10-1)
2. Drive the machine to the attachment and hook the top edge of the quick attach under the upper lip of the attachment.
3. Curl the quick attach slowly upward by moving the lift arm control joystick to the left until the attachment is properly mated with the quick attach mechanism. (Curl enough to lift the attachment off of the ground.)
4. Once the attachment is properly mated, move the two locking levers inward and downward to lock the attachment in place.

Note: When fastening an attachment, always visually verify that the attachment is locked in place prior to operation. (fig. 5.9-2 & 5.9-3)

5 OPERATION

5.10 Unfastening Attachments

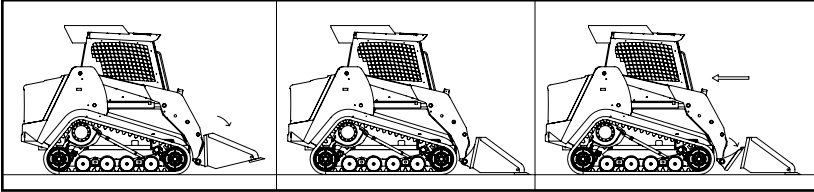

1. Lower the lift arms so that the attachment is just barely off of the ground.
2. Pull the locking levers on the quick attach mechanism upwards and toward the outside of the machine to unlock the attachment.
3. Lay the attachment gently onto the ground by moving the lift arm control joystick slowly to the right.
4. Once the attachment is in contact with the ground, move the lift arm control joystick gently to the right until the quick-attach is clear of the attachment.
5. Back the machine away from the attachment.

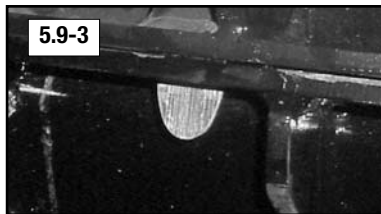
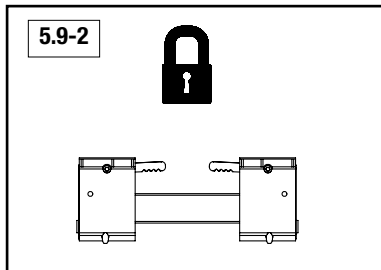
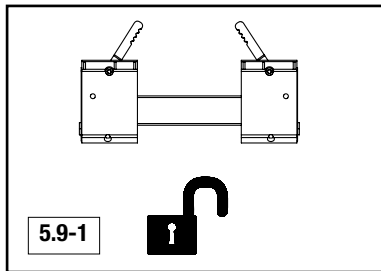

5.12 Operation on Inclines

By design, Rubber Track Loaders are very stable on inclines. Machine weight is distributed evenly throughout the chassis and the suspended undercarriage track system provides excellent traction and floatation on nearly all surfaces.



Even with these capabilities, caution should always be exercised while operating the machine on an incline. Never operate the PT-30 on an incline in excess of 10°. Do not make sudden changes in direction, move slowly, and always carry loads low to maximize machine stability.

When turning on an incline, back down the hill while slowly turning until the machine is pointed in the desired direction. Then proceed forward.

5.13 Shut Down Procedure

1. Stop, lower and disconnect any work attachments that may be coupled to the quick attach.
2. Park the machine in a safe location (on firm and level ground) where it is protected from the elements and vandals.
3. Lower the lift arms until they rest on the frame stops.
4. Reduce engine RPM to a low idle.
5. Turn the ignition key to the off position to stop the engine.
6. Remove the safety belt and raise the lap bar (if equipped).
7. Open the door (if equipped) and exit the machine using 3 points of contact as described in the starting procedure in this section.

5 OPERATION

5.13 Lift Arm Brace

When the lift arms must be left in the raised position, the lift arm brace must be engaged.

To engage:

1. Lower the lift arms, remove any attachments and park the machine on firm and level ground.
2. Remove the pin that secures the brace to the fender.
3. Wrap the spring around the cylinder and attach it to the other side of the brace (fig. 5.13-1).
4. Raise the lift arms until the brace contacts the cylinder rod (fig. 5.13-2).
5. Slowly lower lift arms until the lift arms come to rest (stop) on the brace.
6. Shut the engine off and exit the machine.



To disengage:

1. Remove the spring from the cylinder.
2. Raise the lift arms until the brace falls away from the cylinder rod.
3. Lower lift arms.
4. Turn the engine off.
5. It is now safe to exit the machine and re-attach the brace to fender.



Do not go beneath unsecured lift arms. Always install the lift arm brace prior to going beneath the lift arms while raised.

6.1 Transporting	55
6.2 Towing / Retrieving.....	55
6.3 Loading / Unloading Procedure	56
6.4 Lifting Procedure.....	57

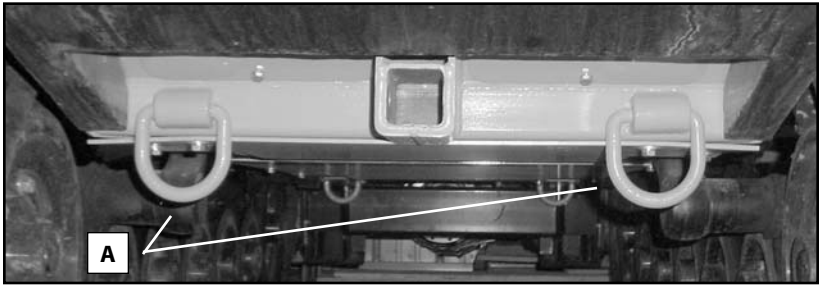

6.1 Transporting

At times, you will most likely need to transport the machine to distant locations with a transport vehicle. To do this safely, there are some precautions that must be observed.

When transporting:

1. Always make sure the transport vehicle (trailer or truck) being used to haul the machine is capable of bearing the weight and size of the machine over the distance and terrain that will be covered.
2. Secure the machine to the transport vehicle bed, facing the direction of travel, with heavy chains rated for use with a machine of this nature (size and weight).
3. Attach the chains to the machine at four points (D-rings), one on each corner of the chassis and secure to suitable locations on the transport vehicle (Items A, see photo). Tighten as needed to eliminate possible load shift during transport.

Note: If your machine is not equipped with D-rings, use the metal loops found similarly in the front and rear (center) of the machine in place of the D-rings for tie down purposes.

Note: Close and latch doors and windows, secure any loose items prior to transporting.

6.2 Towing/Retrieving

In the event that the PT-30 needs to be towed or retrieved, it will not roll freely. You must drag it to safety. Use only chains that are rated for pulling a machine of this size and weight. Attach these chains to **at least two of the D-rings** in the front or rear of the machine. If possible, drag the machine onto a trailer, then secure and transport.

If your machine is not equipped with D-rings, the machine may not be towed or retrieved by pulling or dragging the machine. It must instead be lifted from above through the use of the optional lift kit, or from underneath, supporting the center portion of both of the torsion axles as the machine is placed on a trailer for transport.

6 TRANSPORTATION

6.3 Transport Loading / Unloading procedure

1. Load the machine only on firm and level ground.
2. Before driving onto the ramps, clean them and the machine tracks of any materials that may cause slippage (snow, ice, sludge, etc.).
3. Properly align the machine with the loading ramp.
4. Have a guide give the machine operator any necessary signs to maximize safety during loading.
5. Move carefully onto the ramps and transport vehicle.
6. Have a guide instruct you as to where and when to stop and park the machine. Lower the lift arms and turn off the engine.
7. Before securing the machine, relieve all residual pressure by making sure the operating levers and the auxiliary hydraulic switch are in their neutral positions. Remove the ignition key.
8. Secure the door, windows and hood on the machine.
9. Secure the machine and any other items to the transport vehicle with chains or ropes of the proper capacity.
10. Before departure, investigate the route to be taken, especially in regard to limits for width, height and weight.
11. Pay close attention when driving under electrical lines, bridges, or through tunnels.



Electrocution hazard exists if electrical lines are contacted! Stay clear of electrical lines!

12. To unload, reverse steps 1-9 of this procedure. Use the same caution when unloading as for loading. Remove all cables or chains. Start the engine as described in the operating instructions. Carefully drive down the ramp from the transport vehicle using a guide if necessary to direct movement.

6.4 Lifting Procedure

At times, the PT-30 may need to be lifted with the optional lift kit. This section addresses the proper procedures and attachment points for these activities.

Lifting

Lifting the machine from above should only be done with the optional lift kit installed as shown. (fig. 6.4-1) The machine should only be lifted with a lifting device and chains that are rated for lifting a machine of this size and weight.



The chains must be attached at all four corners of the machine to the lifting eyes and should be connected to a common lift point on the lifting device centered over the machine (use spreader bars if necessary). This will help to balance the machine as well as distribute the weight evenly while being lifted.

Lift the machine straight up in a slow and careful manner. Lower it this same way making sure all bystanders are clear of the machine and its expected path.

If it is necessary to lift attachments or parts from the machine, always use a lifting device and straps/chains rated for lifting items of the size and weight of the component(s) to be lifted.



When lifting attachments or components, use caution. Attach straps or chains securely and in such a way that they evenly distribute the weight of the item to be lifted, ensuring a balanced load. Stay clear of expected travel path.

7.1 General	61
7.2 Care and Cleaning.....	61
7.3 Maintenance Intervals	62
7.4 Lubrication Points.....	63
7.5 Engine Oil Check.....	64
7.6 Engine Oil Change.....	65
7.7 Hydraulic Oil Change	66
7.8 Hydraulic Filter Change	67
7.9 Accessory Belt.....	67
7.10 Water Separator	68
7.11 Fuel Filter Change	68
7.12 General Undercarriage	69
7.13 Track Tension Check.....	69
7.14 Track Tension Adjustment.....	70
7.15 Drive Sprocket Rollers.....	71
7.16 Air Cleaner Removal / Inspection	72
7.17 Air Cleaner Cleaning	73
7.18 Radiator Oil Cooler Cleaning.....	74
7.19 Engine Coolant Change	74
7.20 Chassis Cleaning.....	75
7.21 Electrical System.....	76
7.22 Storage	77

7.1 General

The operating condition and life expectancy of a machine is largely influenced by care and maintenance. For this reason, it is in every machine owner's interest to perform the specified maintenance work and comply with the service intervals.

This chapter describes periodic maintenance, inspection and lubricating tasks. The maintenance interval charts list all work to be performed on the machine at regular intervals.

The supplemental engine operation and maintenance manual provided with every machine contains information specific to the proper operation, inspection and maintenance of the engine and its internal components. This manual must be read, understood and followed in order to properly maintain the engine and comply with warranty requirements.

The operator must have sufficient knowledge to inspect and maintain the machine. The operator should follow the procedures in this manual and take any necessary precautions to ensure his/her safety. Wear appropriate personal protection equipment for all tasks.

7.2 Care and cleaning

Cleaning the machine

- Do not use aggressive detergents to clean the machine. We recommend using commercially available cleaning agents for passenger cars.
- Linings (insulating materials, etc.) should not be exposed directly to water, steam or high-pressure jets.
- When cleaning with water or steam jets, take care not to direct the jet into exhaust and air filter openings.
- When cleaning the engine with water or steam jet, do not expose sensitive engine parts, such as generator, wiring, oil pressure switches, etc. directly to the jet.
- Pay particular attention to the radiator / oil cooler, engine compartment, and chassis area when cleaning. Remove any visible debris from these areas prior to cleaning.
- After wet cleaning lubricate the machine as specified in section 7.4 prior to operation.
- Inspect the machine after cleaning for the presence and condition of safety signs. If any are missing or damaged, contact your dealer immediately to obtain a replacement.

7 MAINTENANCE

7.3 Maintenance Intervals

7.3-1 Daily Maintenance Tasks

Daily		Page
1	Check hydraulic oil level (figure 7.7-3, p-66)	66
2	Check engine oil level	64
3	Check fuel level (gauge on instrument panel)	39
4	Check fan belt tension / condition	67
5	Check track tension / condition	69
6	Check for proper control operation	40
7	Check for proper switch and lighting operation	39
8	Check / clean air cleaner elements	72
9	General visual check for cracks, damage, completeness	22,45
10	Check for leaks in hoses, tubes, valves, pumps, cylinders, etc.	20,29,45
11	Drain water separator	68
12	Lubricate all grease points	63
13	Inspect / clean the radiator/cooler and engine compartment	74-75

7.3-2 50-1000 hour Tasks

Every 50 operating hours		Page
1	Inspect drive sprocket rollers (replace as needed)	71
Every 250 operating hours		Page
1	Replace engine oil & filter	65
2	Replace hydraulic filter(s)	67
Every 500 operating hours		Page
1	Replace hydraulic oil	66
2	Replace fuel filter element	68
Every 1000 operating hours		Page
1	Replace engine coolant (use SCA additive, see engine manual)	74

7.4 Lubrication Points

The illustration below shows the location of grease points found on the left side of the machine. Identical points also exist on the opposite side of the machine. Lubricate all points daily, prior to operation.

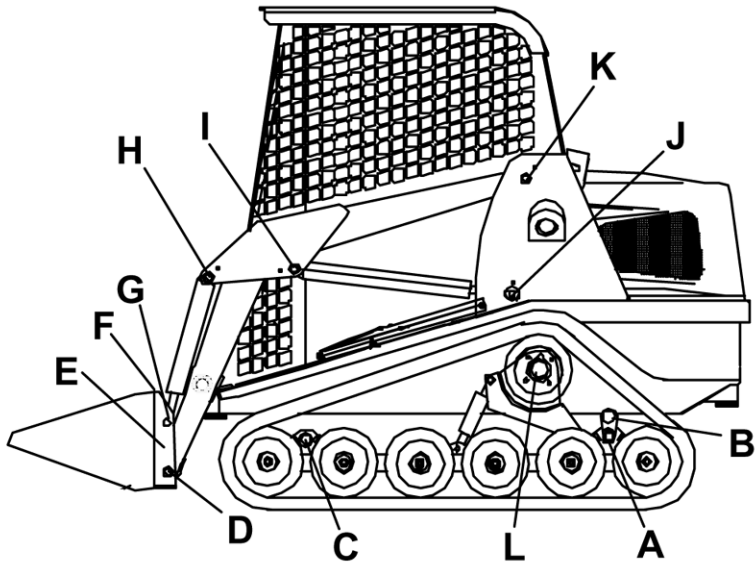

- A - AXLE SWING JOINT, LOWER
- B - AXLE SWING JOINT, UPPER
- C - FRONT AXLE PIVOT POINT
- D - QUICK-ATTACH HINGE POINT
- E - QUICK-ATTACH PIN
- F - QUICK-ATTACH LEVER PIVOT
- G - QUICK-ATTACH CYLINDER PIVOT
- H - QUICK-ATTACH CYLINDER PIVOT
- I - LIFT CYLINDER PIVOT
- J - LIFT CYLINDER PIVOT
- K - LIFT ARM HINGE POINT
- L - DRIVE SPROCKET BEARING

7 MAINTENANCE

7.5 Engine Oil Check

1. Park the machine on level ground, lower the lift arms, stop the engine and remove the key.
2. Open the hood to gain access to the engine compartment.
3. Locate and remove the engine oil dipstick (1) from its tube. (fig. 7.5-1)

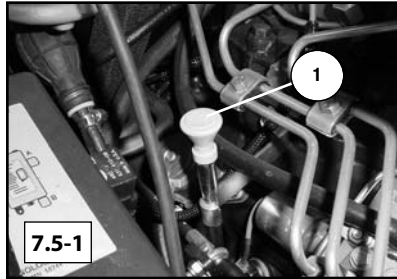

4. Wipe the dipstick with a clean shop cloth and reinsert it into the tube until it comes to rest in its seated position.
5. Remove the dipstick once again and inspect the end for oil on the level indicator.

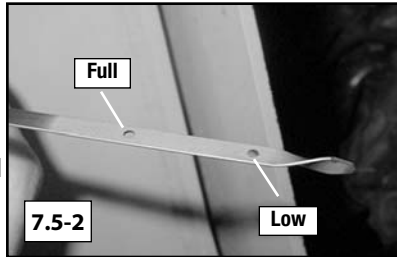

6. Oil should be present on the dipstick up to, but not over the upper (full) level indicator notch. If the level is correct, reinstall the dipstick and then close and latch the hood to complete the procedure. (fig. 7.5-2)
7. If the level is low, add the proper grade and viscosity engine oil and re-check as necessary until the proper level has been achieved. Then re-install the dipstick and filler cap and close and latch the hood to complete the procedure.

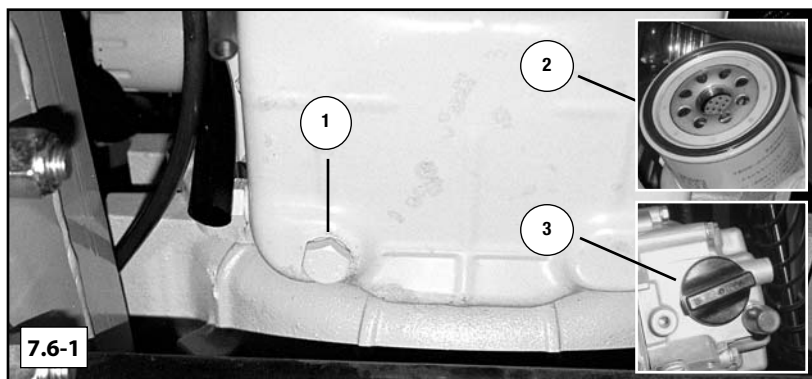

7.6 Engine Oil Change

Regular oil changes are necessary to maintain a strong running engine. Terex recommends a normal oil change interval of 250 hours or every six months. Allow the machine to cool prior to service. Wear safety glasses, safety gloves and any other items necessary to ensure your safety while performing maintenance or service.

To change engine oil:

1. Park the machine in a suitable location for performing service, lower the lift arms, stop the engine, and remove the key.
2. Remove the belly pan beneath the engine to access the drain.
3. Remove the oil drain plug (item 1, fig. 7.6-1) from the pan.
4. Drain the oil into a suitable catch container.
5. Remove engine oil filter. Upon removal, make sure the filter gasket (item 2, fig. 7.6-1) is still present on the filter. If not, remove it from the filter port on the engine prior to installing the new filter to prevent leaks.
6. Apply fresh oil to the new filter gasket surface and install the new filter.
7. Tighten the new oil filter to specifications on filter label or box.
8. Refill the engine to capacity at the location labeled 3 above with oil as specified in the chapter 3, Technical Data.
9. Reinstall the belly pan as found upon removal, and dispose of the used oil and filter according to local mandates.



Oil and machine components can be HOT! Allow the machine to cool thoroughly prior to performing maintenance or service to avoid the possibility of burns.

7 MAINTENANCE

7.7 Hydraulic Oil Change

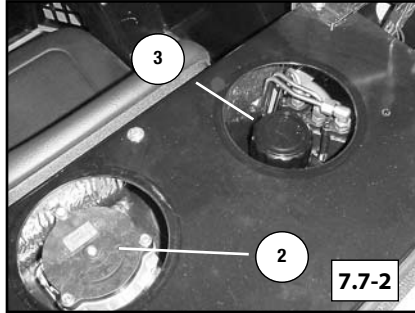
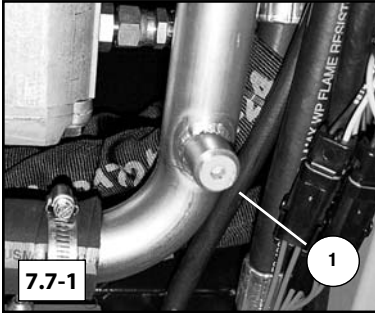

The hydraulic oil should be changed every 500 service hours. Before beginning the procedure, make sure the machine is in a clean working environment. Take any necessary measures to prevent dirt or debris from entering the hydraulic system.

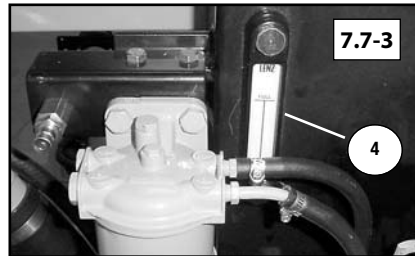

To change hydraulic oil and filter:

1. Park the machine in a location suitable for performing service work, lower the lift arms, stop the engine and remove the key.
2. Allow the machine to cool, then release any residual pressure in the hydraulic system by following the procedure in section 4.4 of this manual.
3. Locate and remove the hydraulic fluid drain plug (item 1) through the drain hole in the belly pan. (fig. 7.7-1)
4. Drain the used oil into a suitable catch container.
5. Dispose of the oil according to local mandates.
6. Reinstall the drain plug and tighten.
7. Refill the hydraulic reservoir (item 3) with Chevron Rykon MV Hydraulic Oil, or equivalent. (fig. 7.7-2)

Note: Observe the hydraulic oil level sight gauge (item 4) located on the back of the hydraulic reservoir to ensure that the level is correct (fig. 7.7-3).

8. Once full, start the engine according to the proper starting procedure and operate all hydraulic circuits to work any trapped air out of the system. Then, check the oil level. If low, add oil as necessary until full.

7.8 Hydraulic Filter Change

The hydraulic filter should be changed every 250 hours. Hydrostatic components require extremely clean oil in order to have a long service life. Use caution when changing the hydraulic filter. Before beginning the procedure, make sure the machine is in a clean working environment. Take any necessary measures to prevent dirt or debris from entering the hydraulic system.

To change the hydraulic filter:

1. Park the machine in a location suitable for performing service work, lower the lift arms, stop the engine and remove the key.
2. Allow the machine to cool, then release any residual pressure in the hydraulic system by following the procedure in section 4.4 of this manual.
3. Locate the hydraulic filter behind the operator enclosure, under the left rubber plug (item 2, fig. 7.7-2).
4. Clean around the filter head, then remove the three bolts securing the cover and remove it.
5. Remove the old filter from the housing and replace it with a new element. Dispose of the used filter according to local mandates.
6. Reinstall the cover and rubber plug as found upon disassembly.

Note: Should a hydraulic hose or fitting need to be removed for maintenance or service, always inspect for damage prior to re-installation. If none is found it may be reused; if damaged, replace the part.

7.9 Accessory Belt

The engine uses a belt to drive accessories like the alternator, water pump, and cooling fan. Belts typically stretch and wear during their service life. As a result, the accessory belt on the PT-30 should be visually inspected daily for tension, condition, and presence prior to operating your machine.

To check drive belt:

1. With the engine off and cool, remove the key from the ignition to avoid accidental start.
2. Raise the hood at the rear of the machine to access the belt.
3. Visually inspect the belt to make sure it is present, tight on the pulleys and in good condition.

7 MAINTENANCE

7.10 Water Separator

The water separator (fig. 7.10-1), located on the left side of the hyd. reservoir) removes water from the fuel supply as the engine runs. Drain the water separator daily to maintain proper function.

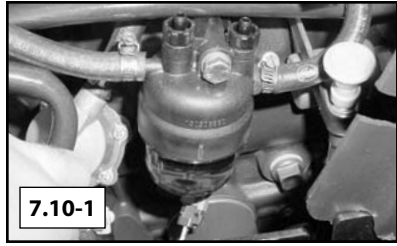

To drain the water separator:

1. With the engine off and cool, and key removed from the ignition, open the hood at the rear of the machine to access the water separator.
2. Loosen the twist valve on the bottom of the separator.
3. Retighten the valve once all of the water has been drained from the catch bowl and close the hood to complete the procedure.

7.11 Fuel Filter Change

The fuel filter should be changed every 500 service hours, or as needed. A plugged fuel filter can cause loss of engine power, rough running, or no start.

To change the filter:

1. With the engine off and cool, and key removed from the ignition, open the hood at the rear of the machine to access the fuel filter.
2. Clean the outside of the filter (1) thoroughly (fig. 7.11-1).
3. Remove bolt (2) on the top of the filter assembly, then remove filter. (fig. 7.11-1)
4. Reverse step 3 to install the new fuel filter into the machine.

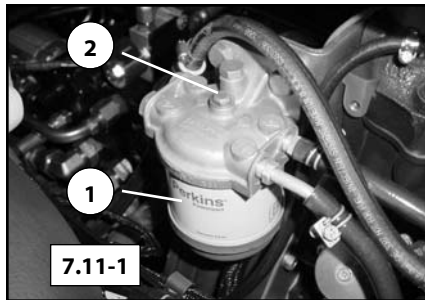

7.12 General Undercarriage Information

The undercarriage assemblies typically operate in harsh working conditions. They work in mud, gravel, debris and various other abrasive materials during operation. Terex recommends a daily inspection of the undercarriage assemblies and cleaning if necessary.

Materials that are particularly sticky or abrasive like clay, mud, or gravel should be cleaned from the undercarriages often to minimize component wear. A pressure washer works well for cleaning materials from the undercarriages. At times when a pressure washer is not available, use a bar, shovel or similar device to carefully remove foreign materials.

When cleaning, pay particular attention to the drive motors/sprockets and the front and rear wheels where debris is likely to accumulate. If working in scrap or debris, inspect the undercarriages more often and remove foreign objects that may wrap around or lodge themselves between components causing premature wear and damage.

Operation on sand, turf, or other finished surfaces may require less frequent cleaning, but daily inspection is still advised.

7.13 Track Tension Check

Proper track tension is important for optimum performance and maximum track life. Operating with tracks that are too loose can cause them to misfeed, possibly causing damage. During the first 50 hours of operation, the tracks will "break-in", and may require adjustment.

To check for proper track adjustment:

1. Drive the machine forward 1.5 meters to remove slack from the lower and rear portions of the track. Stop the engine and remove the key from the ignition.
2. Lay a straight edge along the top of the track, across the sprocket and the front idler wheel (fig. 7.13-1).
3. Using a rope or wire, put 23 kg of down force on the track at the mid point between the sprocket and idler.
4. Using a ruler or tape, measure the distance between the straight edge and track (fig. 7.13-2). The track should not deflect more than 1.9 cm between the top of the track and the straight edge.
5. If the track does deflect more than 1.9 cm, tighten the track until within specification.

7 MAINTENANCE

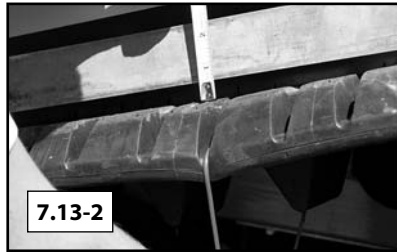

7.14 Track Tension Adjust

1. With the engine off and the key removed from the ignition, locate jam nut on track tension device and clean the threads thoroughly before proceeding. (fig. 7.14-1).
2. Using a wrench, loosen the jam nut on the track tension device.
3. Once the jam nut is loose, turn the tensioner until the track tension is within specification (figure 7.14-2).
4. Turn the tensioner the opposite direction to loosen the track.
5. Once proper tension is achieved, retighten the jam nut on the tensioner.

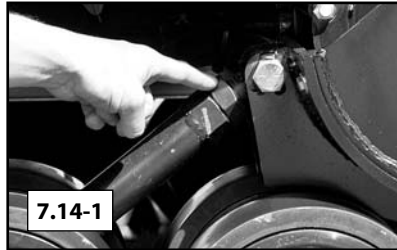

Note: If the track tensioner is stiff, it may be helpful to apply a penetrating lubricant onto the threads prior to adjusting tension.

7.15 Drive Sprocket Rollers

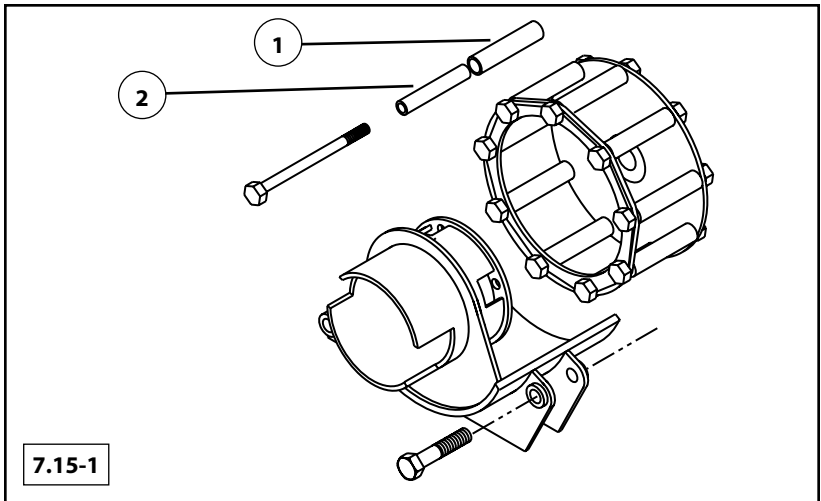

Rubber Track Loaders use rollers on each drive tooth of the drive sprockets. These rollers help minimize friction between lugs on the track and the sprocket. Sprocket rollers should be treated as wear items that are inspected regularly and replaced as needed.

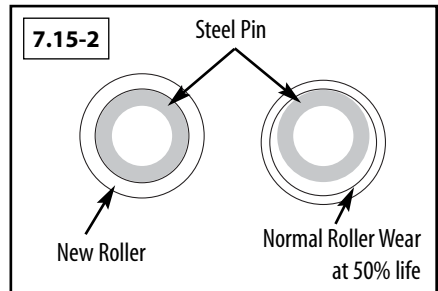

The rollers (1) rotate on steel pins (2), limiting wear to the inside of the rollers. As they wear, the rollers become thinner, but will continue to function and perform as long as they are rotating.

Visually inspect rollers every 50 hours and replace any that show signs of cracking or wear-through.

Drive sprocket removal and roller / pin replacement should be performed by your local Terex dealer.

7 MAINTENANCE

7.16 Air Cleaner Removal / Inspection

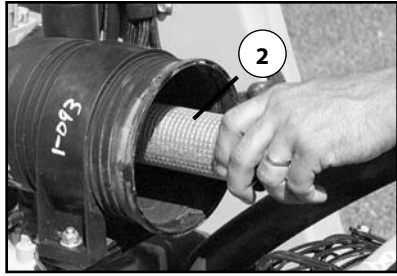
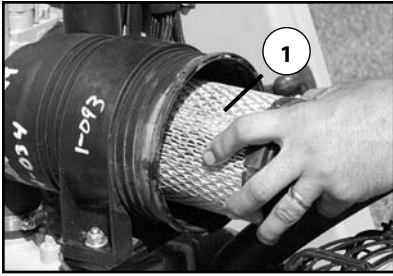

The air cleaner is one of the most important maintenance items on the machine. Regular inspection and replacement is necessary to ensure proper performance and to prolong engine life. **Inspect the air cleaner elements daily.** If damaged or heavily soiled, clean or replace the elements.

1. With the engine off and cool and the key removed from the ignition, open the hood, release the latches on either side of the air cleaner, then remove the cover.
2. Remove the primary element (1). The primary element can be cleaned and reused up to five times, but should be changed at least once a year.
3. Remove the secondary element (2). The secondary element is not serviceable or washable. The secondary element should be replaced every three cleanings of the primary element.

7.17 Air Cleaner Cleaning procedure

1. Remove loose dirt from the element with compressed air or water hose.
 - Compressed air: 690 kPa max. .32cm diameter nozzle at least 5cm away from the filter element.
 - Water: 276 kPa max. without nozzle.
2. Soak the filter element in a non sudsing detergent solution for at least 15 minutes moving it gently through the solution to further clean the element. (Never soak for more than 24 hours.)
3. Rinse the filter thoroughly with a gentle stream of water to remove all dirt and remaining detergent.
4. **Allow the filter to dry completely** before reinstalling it into the machine.

NOTICE

Do not use any heat source other than warm air at less than 71° C to dry the filter.

NOTICE

During the engine warranty period, do not clean the filter elements. Instead, replace the filter elements when soiled or damaged to comply with engine warranty requirements.

7 MAINTENANCE

7.18 Radiator / Oil Cooler Cleaning Procedure

The radiator and oil cooler must be clean to ensure proper operation. Engine and hydraulic system overheating, damage and even failure can result if the radiator/oil cooler is not kept clean. A pressure washer or compressed air nozzle work well to blow debris clear of the fins in the oil cooler and radiator.

To clean radiator / oil cooler:

1. Make sure the engine is off, and cool, and that the key is removed from the ignition during radiator/oil cooler cleaning procedure.
2. Thoroughly clean radiator/oil cooler with a pressure washer or compressed air. Wear any appropriate safety clothing. Direct spray forward through the cooler as shown. (fig. 7.18-1 & 2)

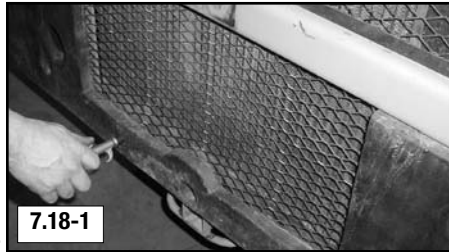

Note: Make sure water nozzle is at least 30.5 cm (20.3 cm for air) from the cooler and that the spray is directed straight through the cooler or the cooling fins may be damaged (bent over) which will decrease cooling performance.

Note: If hydraulic oil or engine coolant temperature lights illuminate during operation, increase cleaning intervals.

Note: In dusty applications check and clean the coolers and chassis often to avoid overheating and prevent fires.

7.19 Engine Coolant Change Procedure

1. With the engine off and cool and the key removed from the ignition, remove the lower rear screen and raise the hood.
2. Open the radiator drain valve (1) and allow the coolant to drain into a catch container.
3. Close the drain valve, then add coolant (with SCA additive) into the radiator through the fill cap until full.
4. Warm the engine to operating temperature, then turn the engine off, remove the key and allow the machine to cool.
5. Check the coolant level, and top off (repeat steps 4 and 5 until all air has been purged and the level is full when cold).

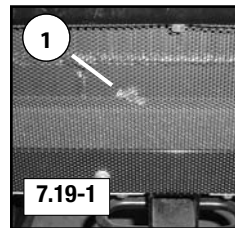

7.20 Chassis Cleaning Procedure

Periodic cleaning of the chassis area beneath the cab and engine compartment is also necessary to maintain safe operation. Clean as necessary. (fig. 7.20-1)

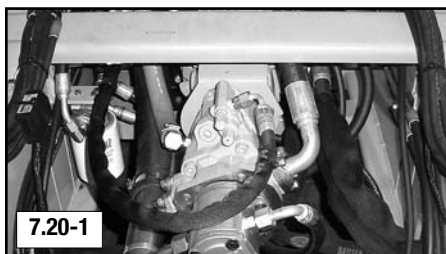

To clean the chassis/engine:

1. With the engine off and cool and the key removed from the ignition, remove the belly pans on the underside of the machine.
2. Raise the hood at the rear of the machine.
3. Pressure wash any debris from the engine compartment and chassis area out through the lower opening.
4. Re-install the belly pans and close the hood to complete the cleaning procedure.

Note: If any safety signs are found to be damaged or missing after cleaning, contact your dealer for a replacement immediately. They can be reapplied according to the location illustration in section 2.4 of this manual.

7 MAINTENANCE

7.21 Electrical System

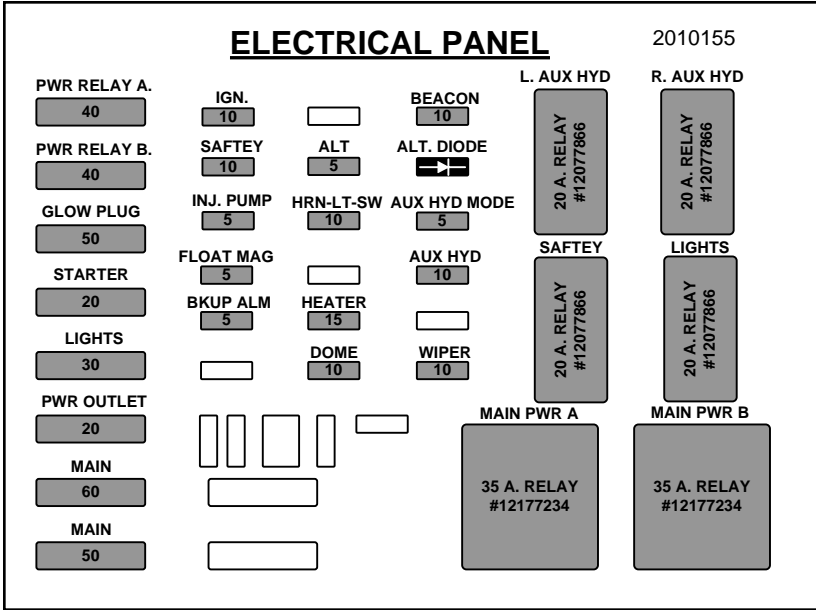

The electrical systems in PT machines are equipped with fuses that help to protect the electrical components from damage. They are found in the fuse panel enclosure which is located on the left side of the engine compartment.

In the event of an electrical malfunction, check the fuse panel. Remove the fuse related to the component that is not working properly and inspect it. If it appears damaged in any way, replace it.

7.22 Storage

It may be necessary to store your Terex Rubber Track Loader for an extended period of time.

Perform the following tasks to prepare the machine for storage.

7.22.1 Storage Preparation

- Thoroughly clean the machine (inside and out) including the engine compartment and underbody. Open hood, remove belly pans and pressure wash to remove all buildup and debris.
- Allow machine to dry thoroughly, then reinstall belly pans, close hood. Touch up any paint blemishes to prevent rust.
- Lubricate all chassis, loader and undercarriage points as indicated on the chart in this chapter. Wipe away any excess grease.
- Replace any worn or damaged components.
- Add fuel stabilizer to near empty fuel tank, then fill to evenly distribute stabilizer throughout fuel.

Note: Run the engine for 5 minutes to circulate stabilized fuel throughout fuel system.

- Park the machine in a dry place that provides protection from the elements.
- Drain and refill the cooling system with 50/50 pre-mixed antifreeze/water.
- Replace engine oil and filter. (ch. 7)
- Replace hydraulic oil and filters (ch. 7)
- Jack the machine and rest the chassis on approved jack stands to remove weight from the torsion axles and suspend the tracks off of the ground.
- Apply protective lubricant (grease) to all exposed cylinder rods.
- Replace air cleaner elements and a/c filter element (if equipped).
- Return all controls to neutral position.
- Cover the exhaust outlet to shield it from the elements and foreign objects.
- Disconnect and remove the battery from the machine. Adjust the electrolyte level if needed and charge before storing. Store in a warm dry place. **Do not allow battery to freeze.** Charge periodically during storage as necessary.
- Label or tag the machine to indicate storage condition.



Battery contents are flammable and corrosive. Contact with skin can cause burns! Do not smoke or allow open flame near the battery to avoid explosion! Wear appropriate PPE.

7 MAINTENANCE

7.22.2 Removal From Storage

Perform the following tasks to remove the Terex Rubber Track Loader from storage and return to operating condition.

Return to Operating Condition:

- Remove protective lubricant from cylinder rods.
- Lubricate all chassis, loader and undercarriage points.
- Safely remove jack stands and lower machine to the ground.
- Install fully charged battery.
- Remove exhaust outlet cover.
- Perform pre-start checklist in chapter 5 of this manual.
- Perform starting procedure (chapter 5)
- Let engine run while observing engine monitoring systems (gauges/lights). Look for anything out of the ordinary. Should the optional engine temp. gauge read excessive temperatures (**or** warning light illuminate) or should the oil pressure or hydraulic oil temp. lights illuminate, shut the machine down immediately. Diagnose and make needed repairs before resuming operation.

Purchasing spare parts

Terex I Ersatzteile GmbH

Postfach 12 64 • D-91534 Rothenburg

Erlbacher Str. 115 • D-91541 Rothenburg

Phone + 49 (0) 9861/972-0

Fax + 49 (0) 9861/972-410

Customer Service

Terex Construction

Motherwell

Scotland

UK

ML1 5RY

Phone +44 (0) 16 98 50 30 77

Fax +44 (0) 16 98 50 32 10