

## INSTRUCTION MANUAL CWL CROSSWEB LABELER



### Global Support:

Phone + 61 (2) 720 521 70  
[sales@baumann-industries.com](mailto:sales@baumann-industries.com)

# TABLE OF CONTENTS

General .....	III	MAINTENANCE	
Specifications .....	III	Passwords .....	4.32
<b>SAFETY</b>		Servo Safety .....	4.33
Personal Safety .....	1.1	Maintenance Log .....	4.34
General Safety Guidelines .....	1.2	Service Log.....	4.34
Installation Guidelines .....	1.2	<b>SCHEMATICS</b>	
<b>STARTUP</b>		Stepper Drive Resistor Locations .....	5.1
Installation .....	2.1	Main Control Box Schematic .....	5.2
Model Identification .....	2.1	Junction Box Cable Schematic .....	5.3
Serial Number.....	2.2	Labeler Signal Diagram .....	5.4
<b>OPERATION</b>		Schematics Layout .....	5.5
Pre-Run Checklist .....	3.1	Stepper Schematics, View 1 .....	5.6
Operation Instructions .....	3.2 Top	Stepper Schematics, View 2 .....	5.7
Threading Diagrams .....	3.5 Bottom	Stepper Schematics, View 3 .....	5.8
Threading Diagrams .....	3.7	Stepper Schematics, View 4 .....	5.9
Main Menu Touchscreen .....	3.9	Servo Schematics, View 1 .....	5.10
Running Menu Touchscreen .....	3.10 Edit	Servo Schematics, View 2 .....	5.11
Menu Touchscreen .....	3.11 Change	Servo Schematics, View 3 .....	5.12
Parameter Instructions .....	3.12 Name	Servo Schematics, View 4 .....	5.13
Program Touchscreen .....	3.14	Pneumatic Diagram .....	5.14
Load Program Touchscreen .....	3.14	<b>PARTS</b>	
Security Touchscreen .....	3.15	Recommended Spare Parts .....	6.1
SICK Label Sensor Setup .....	3.16	Label Tower .....	6.4
Clear Label Setup .....	3.17	Dancer Arm .....	6.6
<b>MAINTENANCE</b>		Tension Roller .....	6.7
Prior to Cleaning .....	4.19	Take-Up Unit .....	6.8
Cleaning Instructions .....	4.19	Drive Roller .....	6.10
Maintenance Screen .....	4.20 I/O	Roller, 2-in. Nominal .....	6.11
Screen.....	4.21 Copy	Label Head Assembly .....	6.12
Programs .....	4.21	Tamp Unit, 320mm .....	6.14
Options Screen .....	4.22	Tamp Unit, 420-520mm .....	6.16
Predispense Screens .....	4.23	Tamp Unit, 620-820mm .....	6.18
Optimize Shift Screen.....	4.23	Transfer Belt Assembly, 320mm .....	6.20
Non-Stop Screen .....	4.24	Transfer Belt Assembly, 420mm .....	6.22
Head-to-Head Screens .....	4.25	Transfer Belt Assembly, 520-820mm ..	6.26
		Push Blade, 320mm, Shielded .....	6.30
Miscellaneous Options, Page 1.....	4.26	Push Blade, 420-520mm, Shielded ....	6.32
Miscellaneous Options, Page 2.....	4.27	Push Blade, 620-820mm, Shielded ....	6.34
Language Option, Page 3 .....	4.28	Twin Tower Option .....	6.38
Non-Standard Placement .....	4.29	Chassis Assembly .....	6.40
Multiple Spaces Editing .....	4.30	Longitudinal Shift Assembly .....	6.41
Multiple Offsets Editing .....	4.30	Carriage Drive Assembly .....	6.42
Low Label Detection .....	4.31	Carriage Bearing Assembly .....	6.44
Empty Package Detection .....	4.31	Bearing Tube Assembly .....	6.45

# TABLE OF CONTENTS

## PARTS

Carriage Belt Clamp Assembly .....	6.46
Label Reel .....	6.47
Idler Roller Set Assembly .....	6.48
Idler Roller Assembly, 2-in. ....	6.49
Idler Roller Assembly, 1.25-in. ....	6.50
Super-Torque Label Head/Shift Motor ...	6.51
High- and Standard-Torque Label Head/Shift Motor .....	6.52
High- and Standard-Torque Transport/ Package Motor .....	6.53
Servo Motor Assembly .....	6.54
Servo Safety Guard .....	6.55
Controls Loom Assembly .....	6.56
Chassis Bracket Assembly .....	6.57
Chassis Loom Assembly .....	6.58
Pneumatics Mounting Bracket Assembly ...	6.59
Control Cabinet Assembly .....	6.60
Control Cabinet Assembly .....	6.61
Circuit Board Assembly .....	6.64
Cables .....	6.66
Servo Motor Control .....	6.68
Clear Label Detector (Option) .....	6.69

## DATE CODE PRINTER

Printer Safety .....	7.1
Printer Threading and Adjustment .....	7.2
Printer Setup Touchscreen .....	7.4
OEM300 Hot Foil Printer Spare Parts ....	7.5
OEM300 Cable Schematic .....	7.5
OEM300 Hot Foil Printer .....	7.6
Printer Bracket Assembly.....	7.10
Troubleshooting .....	7.14

## TROUBLESHOOTING

Sensing and Dispense .....	8.1
Transport Across Web .....	8.4
Placement in Machine Direction .....	8.6
Tamp .....	8.7
Labeler Speed .....	8.9
Blow-On and Display .....	8.10
Common Fault .....	8.11
Drives, Faults, and Sensors .....	8.12
Sensors, Labels, and Motor .....	8.13
Power and Tamp .....	8.14
Date Code Printer .....	8.15

## PROGRAM PARAMETERS

Program Parameters .....	9.1
Global Parameters.....	9.1

## INDEX .....

.....	10.1
-------	------

# Matrix™ Crossweb Package Labeler

Congratulations on your Matrix™ Crossweb Package Labeler purchase. The labeler was designed to give you years of trouble-free operation.

Please read this owner's manual to gain the maximum benefits of your labeler and its different components.

**A note about cleaning:** Given all the various ways equipment is used in different environments, we recommend the owner consult sanitation experts on how to properly clean each piece of machinery in their plant and to do bacterial testing to insure that the equipment is cleaned properly.



**For Technical Support (Australia)**

Phone + 61 (0) 423 544 686

e-mail: [sales@baumann-industries.com](mailto:sales@baumann-industries.com)

## General

This owner's manual contains information pertinent to your Matrix™ Crossweb Package Labeler. Basic instructions and maintenance information is provided. Please read carefully. Failure to do so could result in bodily injury and/or damage to the equipment.

**Receiving Problems:** As in all cases, before signing the bill of lading, be sure all items have been received as listed and there is no damage in shipment. If needed, a claim must be made immediately to the local truck line office and noted on the bill of lading.

Please fill in the information from the bill of lading and the product identification tag.

## Specifications

**Construction:** Stainless steel, Delrin, and PET-P construction

**Electrical:**

208-240 VAC, 50/60 Hertz, single phase, 6.0 amps

**NOTE:** Power must be maintained at all times to the labeler control, even when the labeler is turned off. This is to maintain power to an internal, thermostat controlled heater to reduce condensation in the electronics. It is recommended that a separate power drop be made to the labeler. It is internally fused to 4A.

**Note:** Specifications are subject to change at any time.

# SAFETY

## Personal Safety

The procedures and guidelines herein must be followed precisely to avoid problems that can result in property damage, personal injury, or death. If you have any questions related to this information, please contact Ultravac Services Inc. at (800) 777-5624.

**⚠ DANGER** Hazardous voltage.

Disconnect and lockout power before servicing machine or cleaning. Do not remove panels unless power has been disconnected and locked out at risk of electric shock hazard.

**⚠ WARNING**

Read and understand owner's manual before using this machine. Failure to follow operating instructions could result in personal injury or damage to equipment.

**⚠ WARNING** Moving parts. Pinch point hazard.

Do not put hands into machine while running. Ensure that the conveyor is not operating prior to freeing product or handling conveyor. Conveyor creates pinch point and draw in hazards.

**⚠ CAUTION** Hot surfaces. Do not touch.

To avoid possible skin burns disconnect and lockout power. Allow surfaces to cool before servicing or cleaning.

**⚠ CAUTION** Cleaning agents.

Do not get the cleaning agents in eyes, on skin, or on clothing. Always wear rubber gloves, goggles, and protective clothing when contact is likely. Consult product manufacturer for specific details.

Signal words used in classification of potential hazards are defined as follows:

**DANGER:** Indicates an imminently hazardous situation, which, if not avoided, may result in death or serious injury.

**WARNING:** Indicates a potentially hazardous situation, which, if not avoided, could result in death or serious injury.

**CAUTION:** Indicates a potentially hazardous situation, which, if not avoided, may result in minor or moderate injury. Caution also indicates actions that may cause property damage.

# General Safety Guidelines

## **Obvious safety guidelines should be observed.**

- Be sure to unplug the power cable to the labeler before any maintenance work is performed. Turning off the power switch will not remove all voltage internally.
- Never go near the machine with loose hair, clothes, bracelets, chains, rings, ties, etc. to avoid the chance that they may become tangled in the moving parts of the machine.
- As a consequence, the operator shall wear suitable clothes for the working environment and the situation he/she is in.
- If service is necessary, contact Ultravac Services Inc. or a qualified service agency.

# Installation Guidelines

- It is the owner's responsibility to ensure that the Matrix™ Crossweb Package Labeler installation conforms to all local, state, and national codes and regulations.
- For safe operation, the labeler must be kept clean. A thorough weekly cleaning schedule is recommended with a basic daily cleanup procedure. See *MAINTENANCE*, page 4.1, for additional details on cleaning your labeler.
- Never make any additions or modifications to the Matrix™ Crossweb Package Labeler without contacting Ultravac Services Inc. This will void the warranty and could adversely affect the safety or operation of your labeler.
- DO NOT attempt to operate your Matrix™ Crossweb Package Labeler without reading and understanding this entire owner's manual. Any questions should be directed to Ultravac Services Inc.

# STARTUP

## Installation

The installation of the Matrix™ Crossweb Package Labeler should be performed by a Ultravac Services Inc. service technician or qualified Packaging Machine OEM technician. If you are installing the Matrix™ Crossweb Package Labeler, contact Ultravac Services Inc. at (800) 777-5624 for telephone assistance.

**NOTE: 220 VAC POWER MUST BE MAINTAINED CONTINUOUSLY TO THE LABELER IN HARSH ENVIRONMENTS.**

Power must be maintained at all times to the labeler control, even when the labeler is turned off. This is to maintain power to an internal, thermostat controlled heater to reduce condensation in the electronics. It is recommended that a separate power drop be made to the labeler. It is internally fused to 4A.

## Model Identification

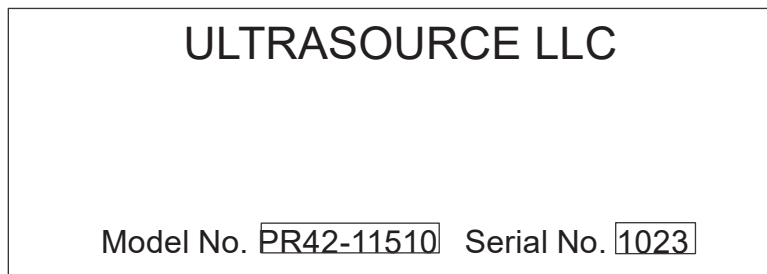

The Matrix™ Crossweb Package Labeler model number is a nine-digit code that when broken down describes the separate components that make up your labeler. The example below shows how.

Model number detailed below:

**PR 42 - 1 1 5 1 0**

Unit Type/ Orientation		Chassis Web Width		Max. Label		Label Transport		Labeler Shifting		Motors		Printing		
PR	Right- Hand	32	320mm	1	150 mm	1	150 mm	0	No Shift	0	Standard	0	None	
		42	420mm	2	200mm	2	200mm	5	Shifting	1	High- Torque	1	Thermal Transfer	
PL	Left- Hand	52	520mm	9	Special	9	Special			2	Super- Torque	2	Markem, Transfer	
		62	620mm											
		72	720mm											
		82	820mm										3	HS 330S
		99	Special										4	HS 1000S
												6	Ink Jet	
													7	CCI
													9	Special

# OPERATION

## Pre-Run Checklist

- ✓ Make sure label transporter belts, tamp blades, and peel bar are free of labels or debris, clean as necessary.
- ✓ Make sure tension roller is locked down.
- ✓ Make sure label brake arms are down.
- ✓ Make sure label reel is tightened against label roll.
- ✓ Make sure dancer operation stops label roll from unwinding.
- ✓ Verify threading, particularly in peel bar area and label sensor area.
- ✓ Drain water from pressure regulator/water separator on the labeler.

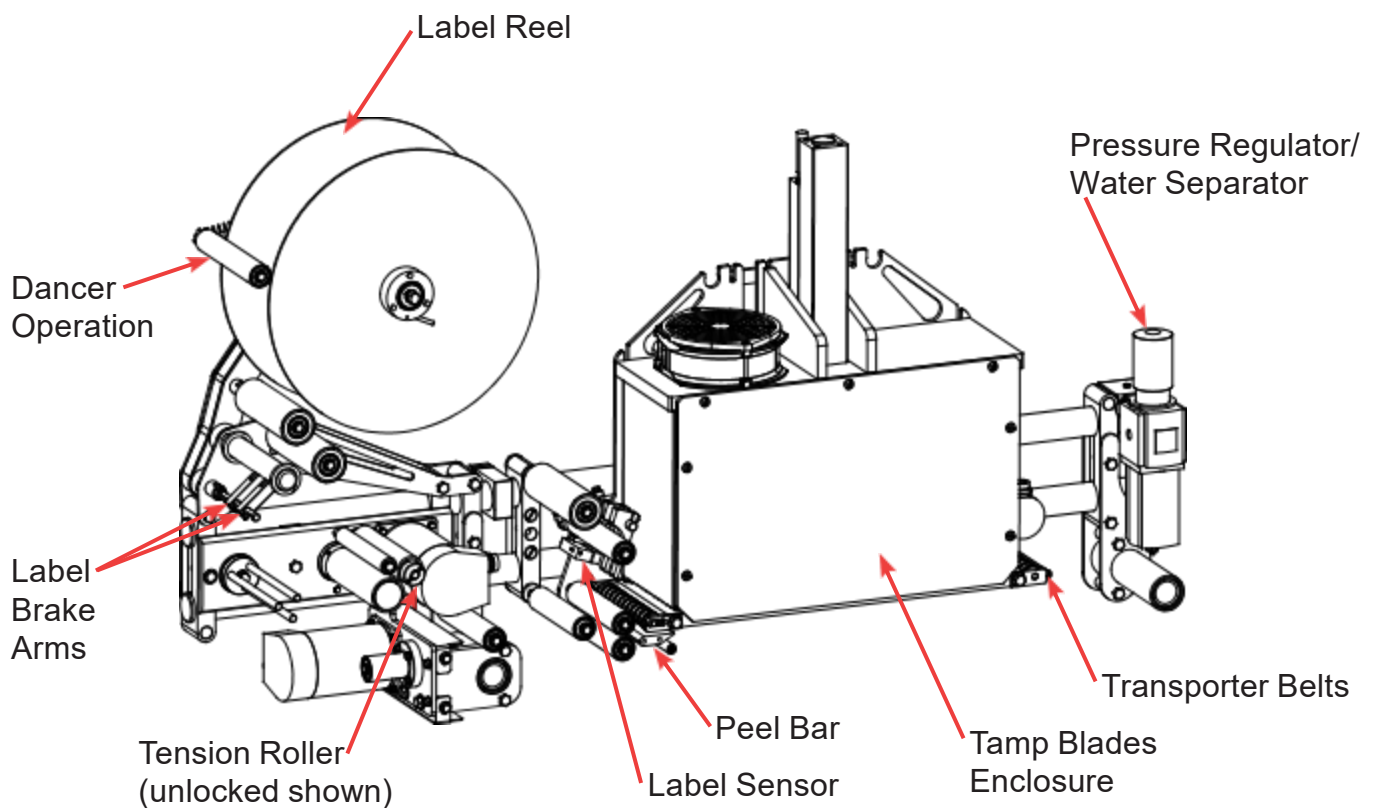

Figure 3.2

# Operation Instructions

1. Turn on the Matrix™ Crossweb Package Labeler by turning the switch to the 'ON' position on the control cabinet.
  - For shifting or multiple row labelers - be aware of the machine "homing" at power up. Ensure the home sensor is between the EOT carriage sensor blocks.
2. Upon power up, the Matrix™ Crossweb Package Labeler will be in either the STOP condition and display the MAIN menu (see page 3.9) or the ready to run condition and display the RUNNING menu (see page 3.10).
3. From power up, the Matrix™ Crossweb Package Labeler will operate with the parameters that were last active at power down. Individual parameters may then be changed (see EDIT screen, pages 3.11-3.13) or a new set of parameters can be loaded from memory (see LOADING PROGRAMS screen, pages 3.10 and 3.14).
4. This owner's manual section is organized by screens. Each section details actions that can be performed from the operating screens.
5. To set up the Matrix™ Crossweb Package Labeler for a new label and application, the following steps must be performed:
  - Thread the label roll into the labeler. Ensure tension roller is engaged. See pages 3.5-3.8 for threading diagrams.
  - Perform a label sensor sensitivity adjustment, see pages 3.16 and 3.17.
  - Perform a label measuring run, see page 3.9.
  - Set each of the parameters (see page 3.13) and return to the RUNNING screen (see page 3.10).

## Operation Instructions

5. The Tamp Unit and Label Reel positions are also adjustable as shown below.

Tamp unit position should be adjusted to minimize tamp stroke. The closer the unit can be adjusted to the product surface, the faster the labeler will operate.

**TO ADJUST:** Loosen bolts, adjust height, and retighten bolts.

**CAUTION:** Tamp unit is **heavy** and will fall when bolts are loosened.

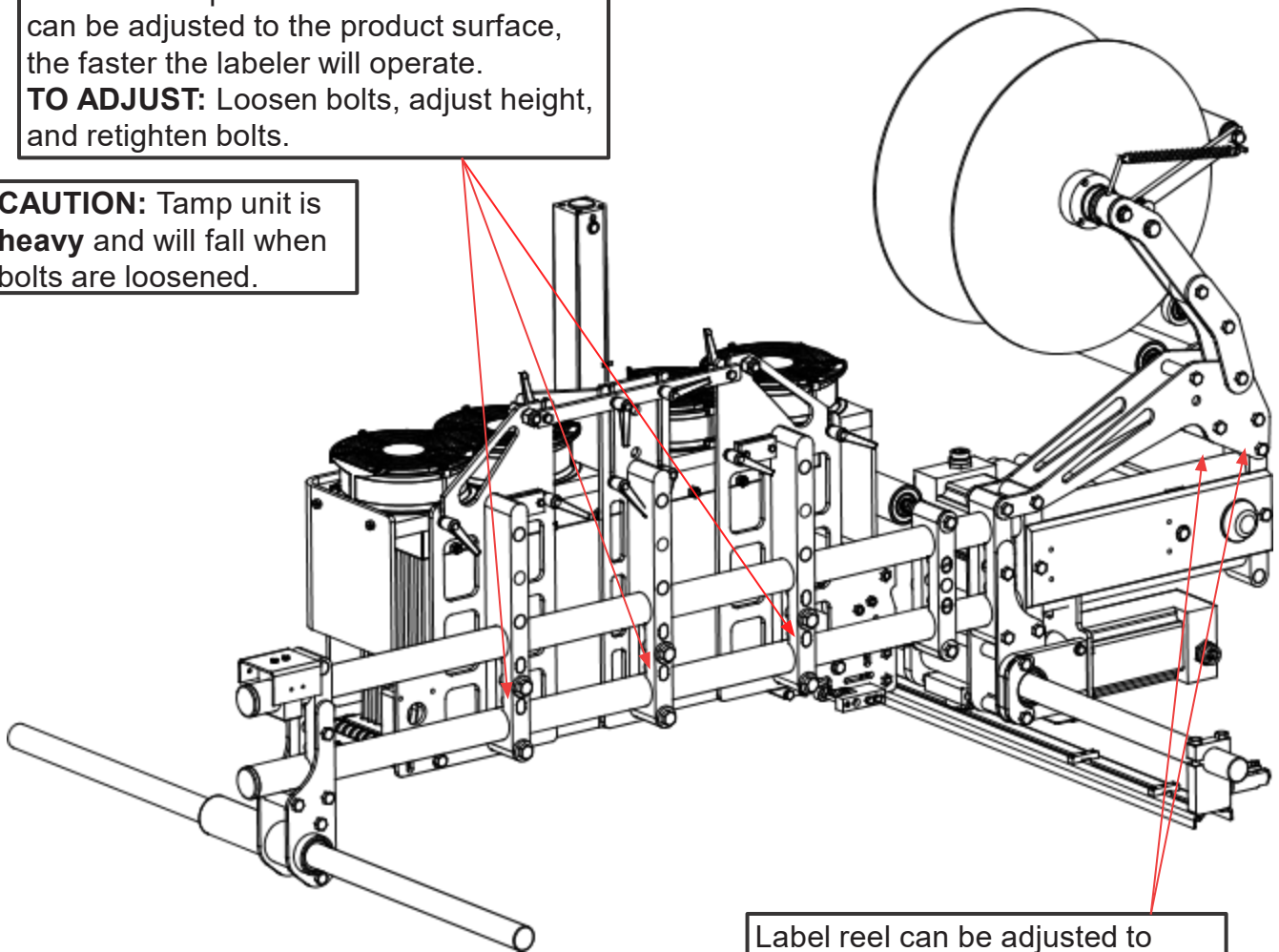

Label reel can be adjusted to three (3) different positions to provide the optimal ergonomic loading position (depending on installation).

**TO ADJUST:** Remove bolt, rotate bracket, and reinstall bolt.

# Operation Instructions

6. The Label Sensor and Peel Bar positions are also adjustable as shown below.

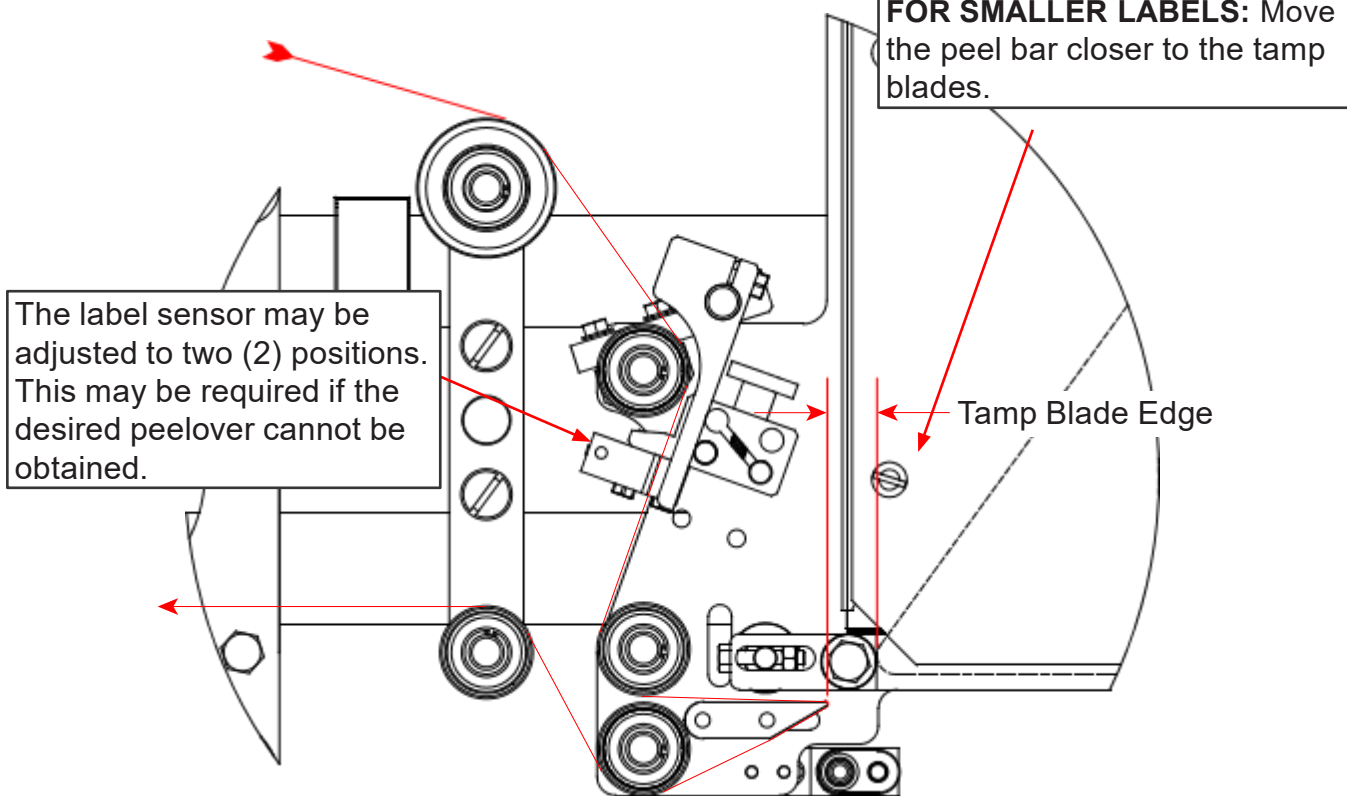
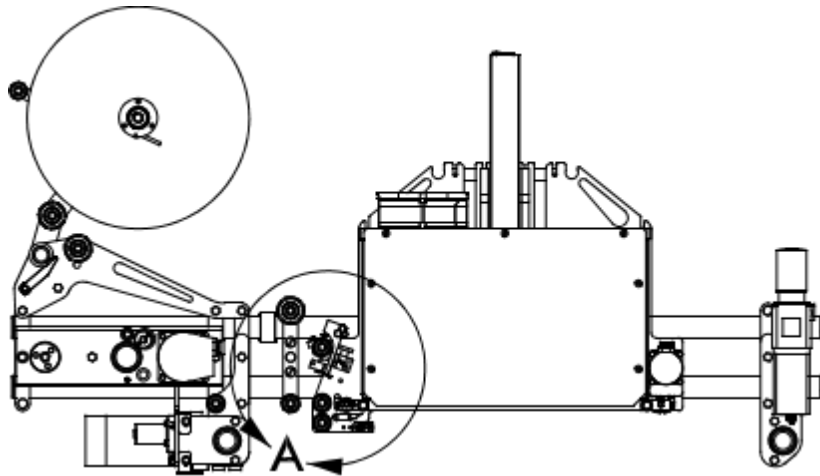

# Top Threading Diagrams

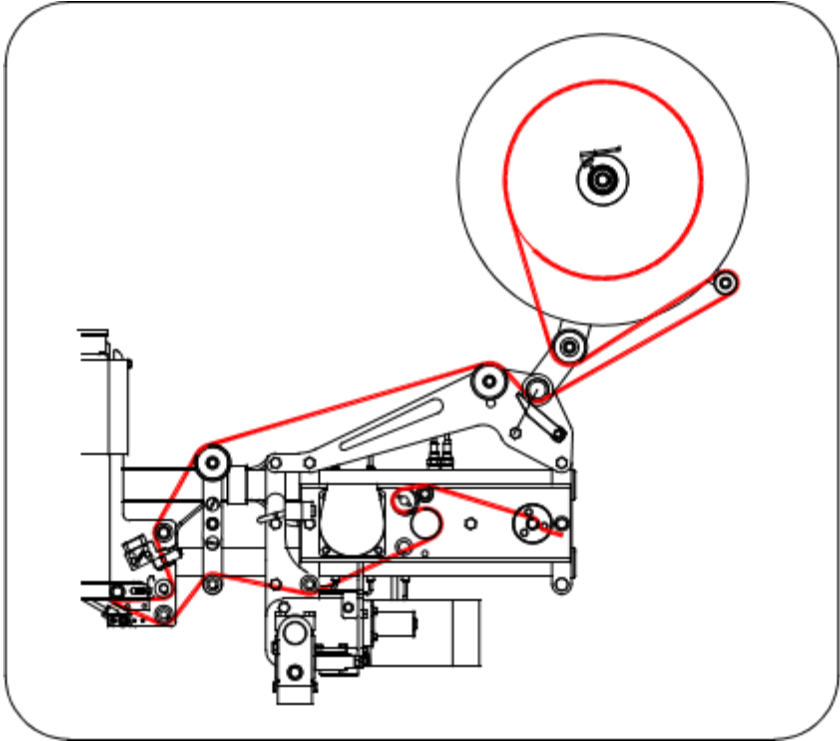

Left-Hand (above)  
Right-Hand (below)

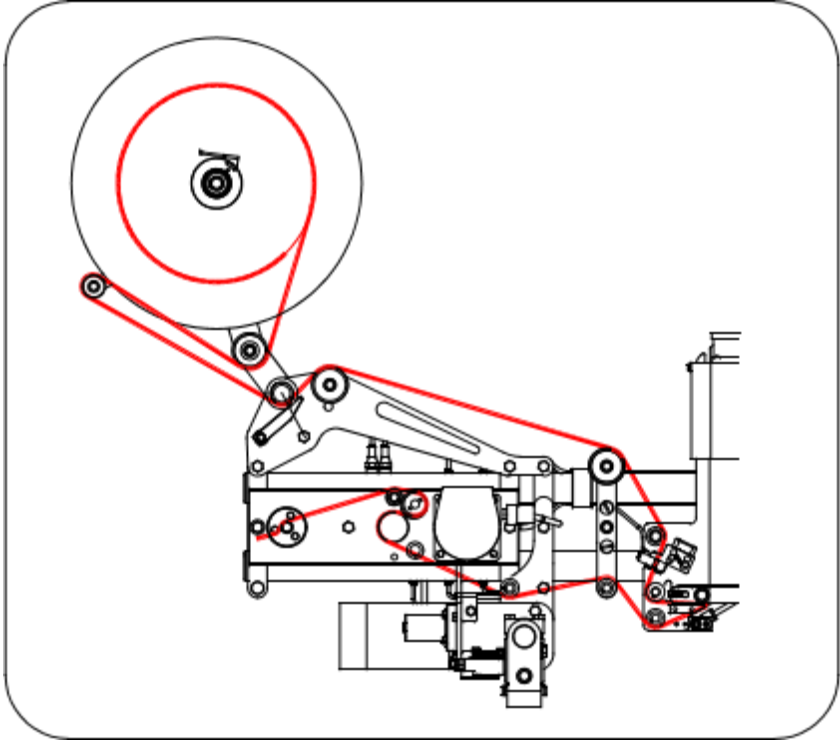

# Top Threading Diagrams with Markem Printer

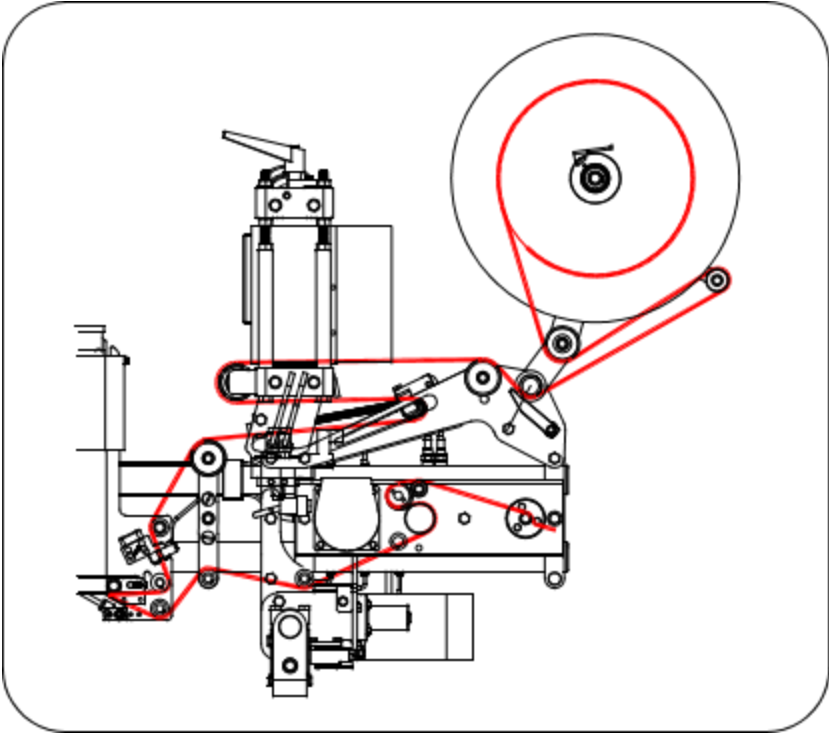

Left-Hand (above)  
Right-Hand (below)

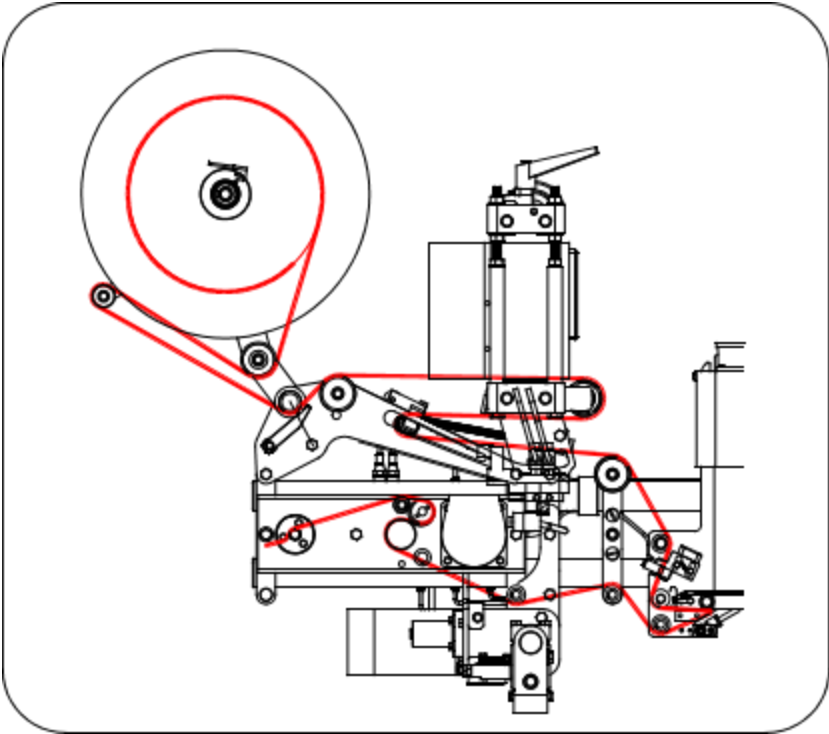

# Bottom Threading Diagrams

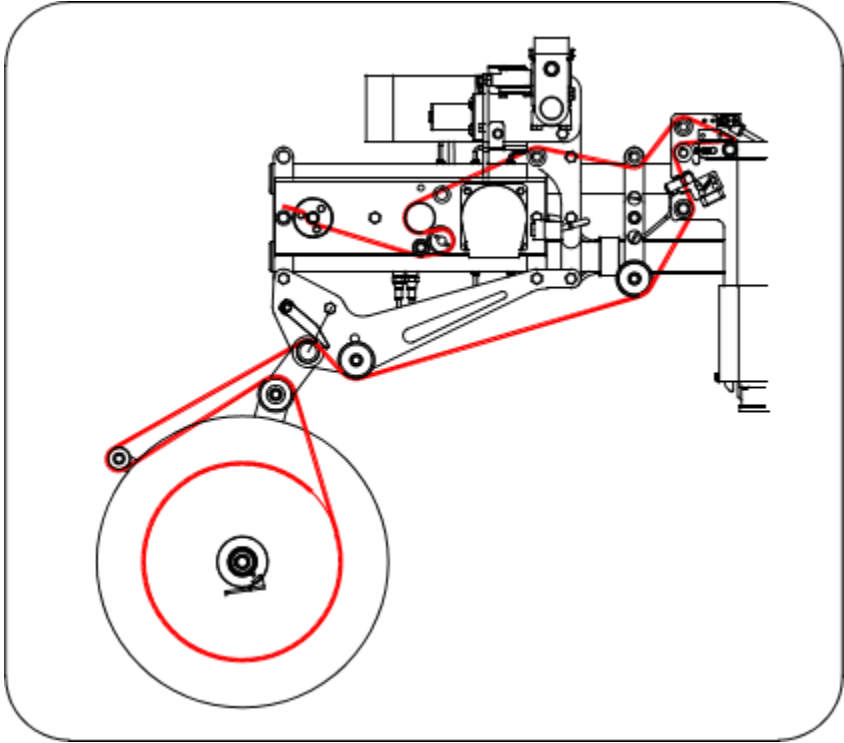

Left-Hand (above)  
Right-Hand (below)

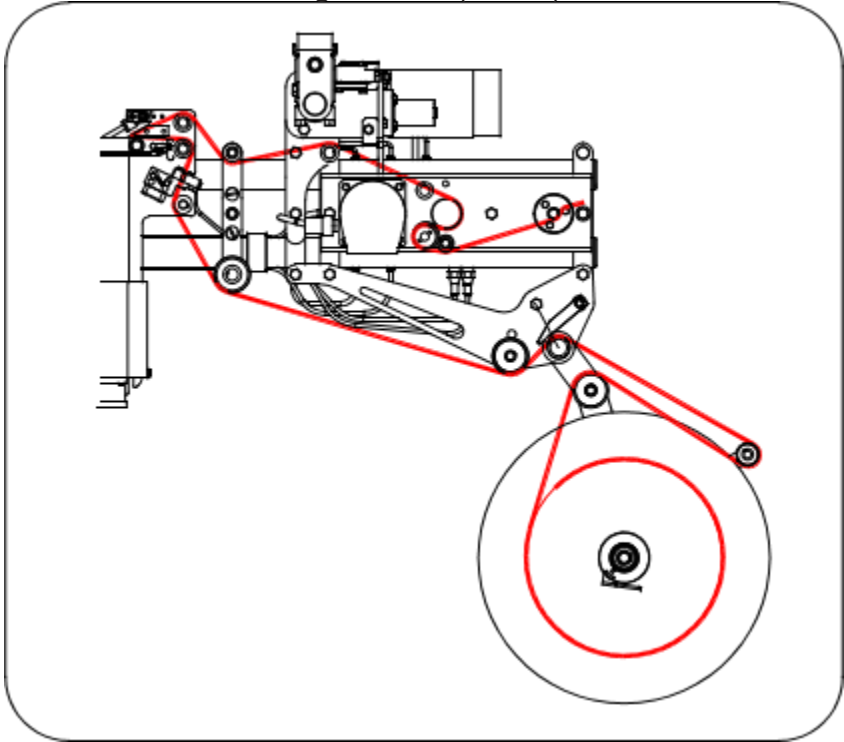



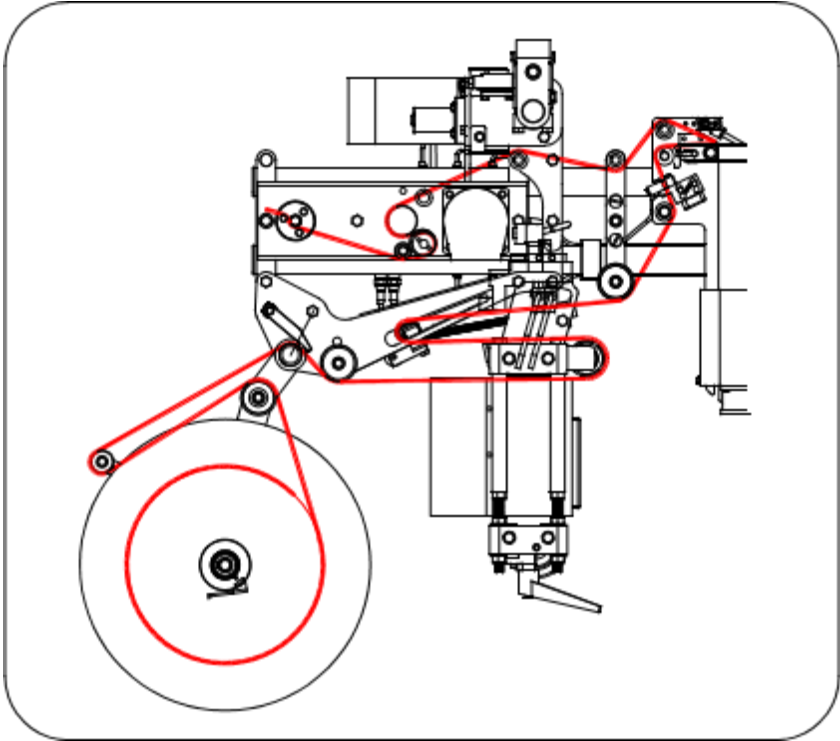



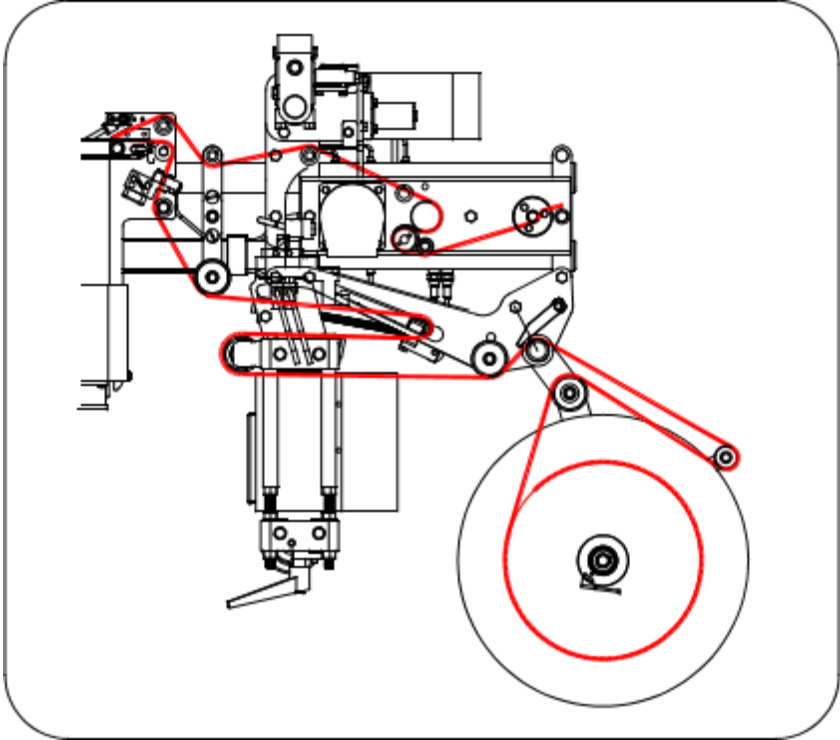

# Bottom Threading Diagrams with Markem Printer

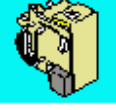

Left-Hand (above)  
Right-Hand (below)

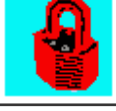

## Main Menu Touchscreen

	RUN LABELER	Puts the labeler into the RUNNING mode where labels will be dispensed. Also allows editing of parameters. See page 3.10.
	PHOTOEYE SET	Displays instructions on setting the label sensor sensitivity. See pages 3.16 and 3.17.
	PRINTER SETUP	Setup OEM300 Hot Stamp or other optional printers. See page 7.4.
	MAINTENANCE	Press to set the motor accelerate rates, test individual motors, and set motor count. See page 4.20.
	REV : 0.00:	Displays software revision, special options, and a graphic indicator (package/film)
	NAME PROGRAM	Names the current program. See page 3.14.
	SECURITY	Enables supervisors to change passwords. See page 3.15.
	MEASURE LABEL	Performs a label measuring run (or the label length can be entered directly).
	LOAD PROGRAM	Loads a set of saved parameters. See page 3.14.

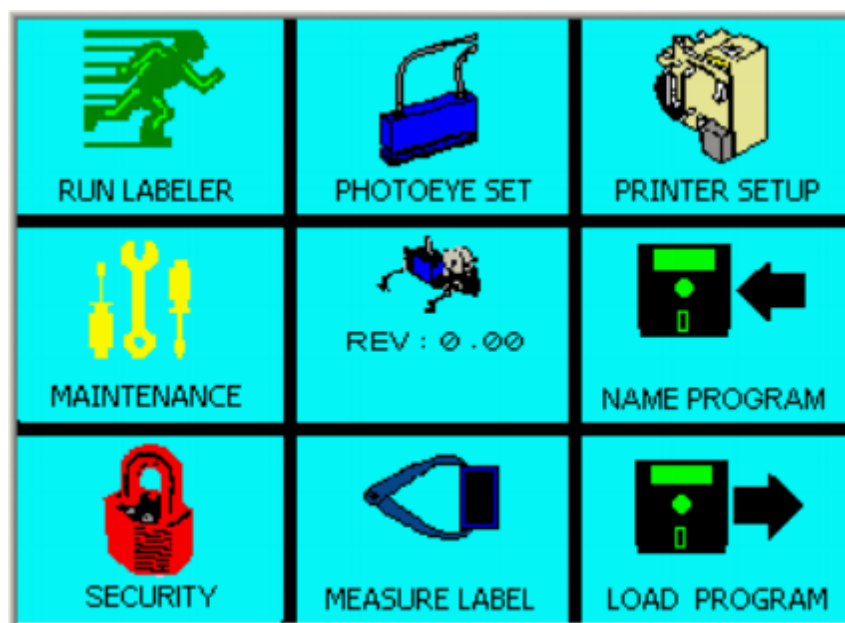

# Running Menu Touchscreen

	STOP	Touch the STOP key to stop the labeler and go to the MAIN menu
	ROW	Dispenses row of labels without tamping
	CYCLE	Executes one complete cycle by placing one label set
	HOME	Sends the labeler to row #1 position (if labeler is multi-row)
	Signal Indicator	Displays receiving signal from rollstock machine. (1=open signal; 0=closed signal). See schematic, view 2 on pages 5.7 or 5.11.
	RUNNING : CYCLES :	Displays current program name, number, and cycle count

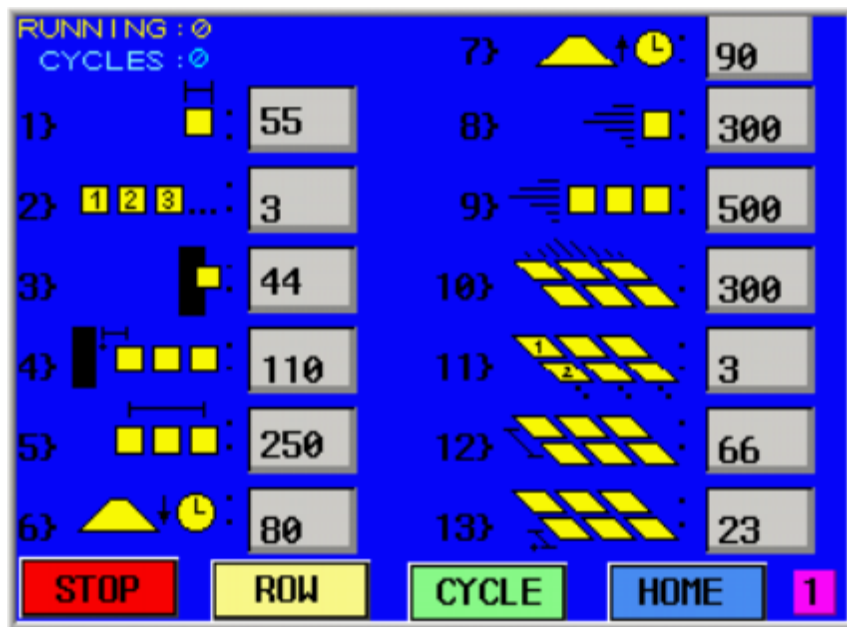

## Edit Menu Touchscreen

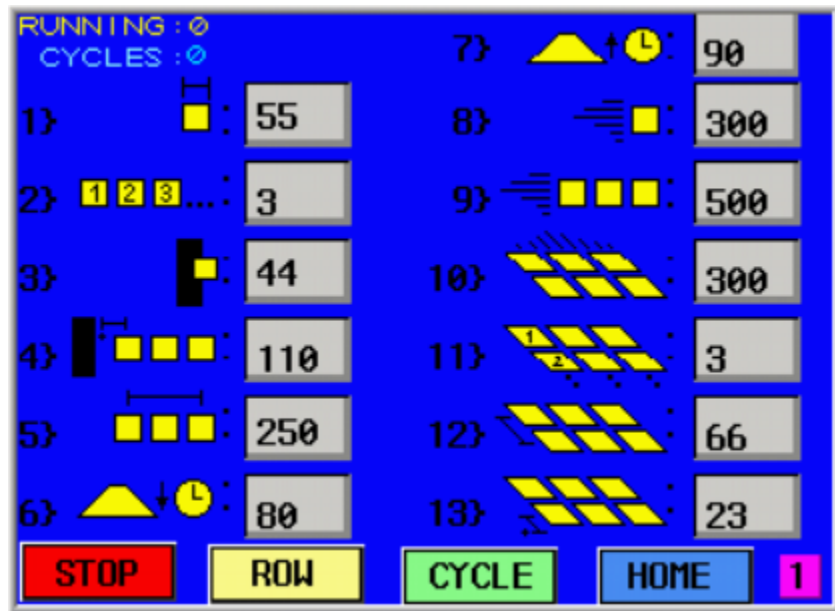

Parameter No. and Name	Description	
1	Label Length	Directly edited or measure run (mm)
2	Labels per Row	Number of labels per row across the machine
3	Label Sensor Distance	Distance from label sensor to trailing edge of label (mm)
4	Offset Distance	Distance from center of last label to peel bar (mm)
5	Spread Distance	Distance from center of first label to center of last label (mm)
6	Tamp Time	Down stroke of pusher blades (Range: 50 to 250ms)
7	Tamp Wait Time	Up stroke of pusher blades (Range: 50 to 250ms)
8	Label Speed	Standard range: 200 to 1000mm/sec
9	Transporter Speed	Standard range: 200 to 2000mm/sec
10	Row Shift Speed	Standard range: 150 to 500mm/sec
11	Number of Rows	Number of rows longitudinally
12	Row Distance	Distance (mm) (Minimum value: 20)
13	Row Offset	Offset from home sensor (mm) (Minimum value: 10)

If the row offset requires a setting outside these limits, then the home proximity sensor must be readjusted to allow the shifting head to locate the sensor. See page 3.13 to change parameters.

**Note:** After editing a parameter on a multiple row (shifting) labeler with ROWS = 1, press the HOME button to re-home the labeler to set the holding current on the motor to maintain a locked position. This only applies if parameters are edited. The labeler will automatically home and lock when powered up.

# Change Parameter Instructions

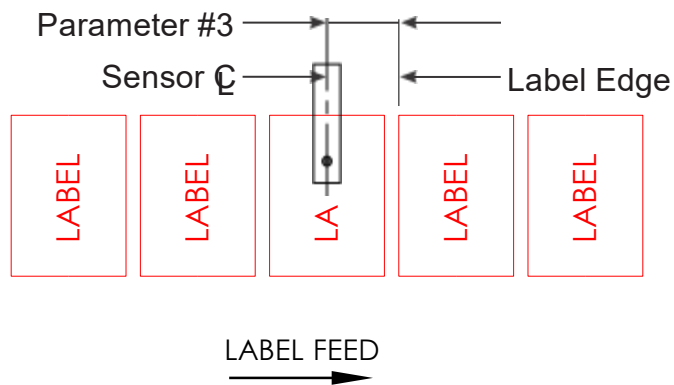
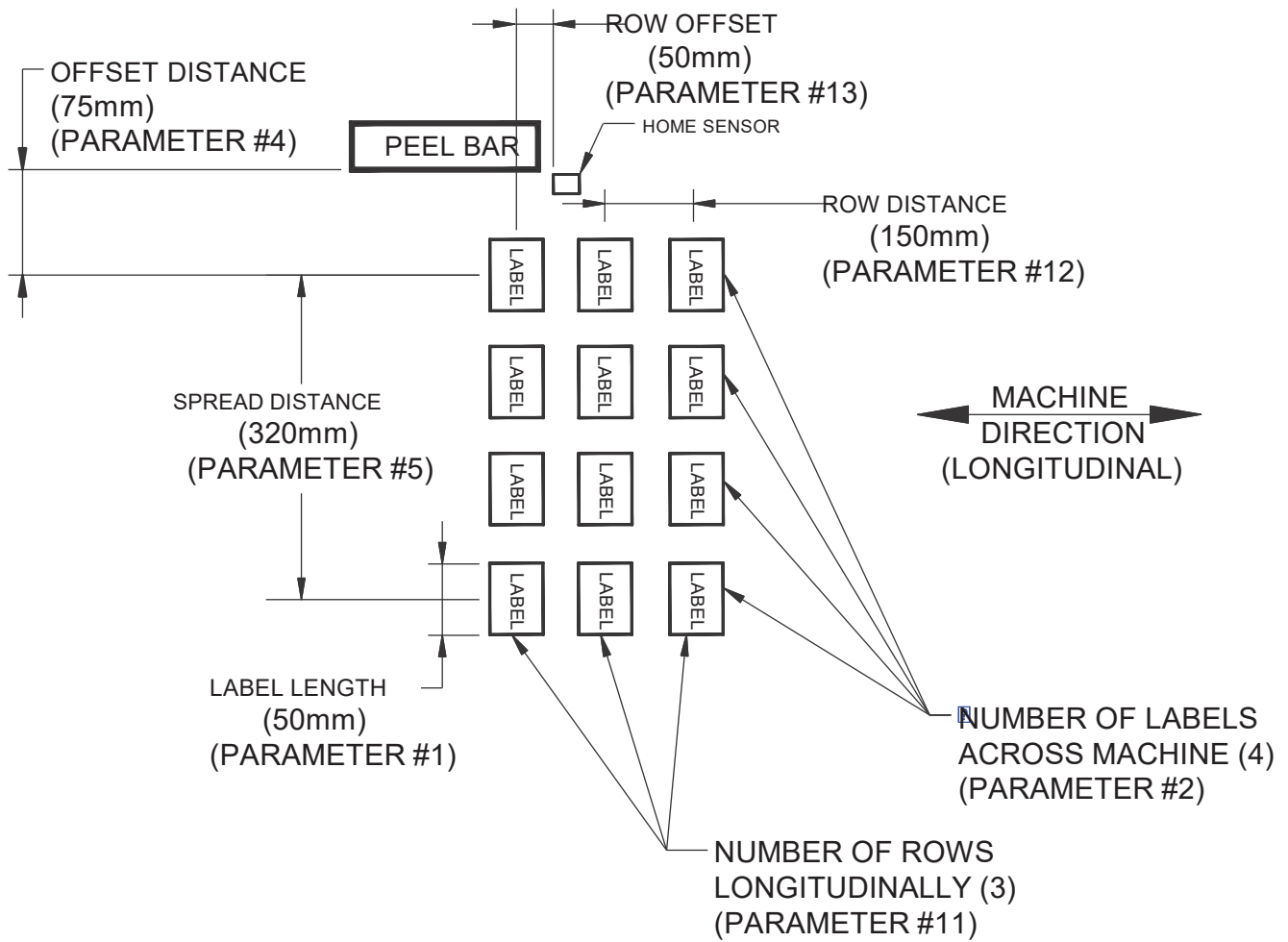

## Change Parameter Instructions

1. Touch the desired parameter's box. To copy one program to another, see the Maintenance section on pages 4.20 and 4.21.
2. A yellow cursor will flash on the selected number and a keypad will be displayed to enter the value desired.
3. After entering value, press the ENT button.
4. After pressing the ENT button, the system will automatically save the value into the current program.
5. Press the STOP button to return to the MAIN menu.

**NOTE:** Labeler will be interrupted during the editing process. When the Matrix™ Labeler is powered down, the current parameters are stored in nonvolatile memory and are automatically reloaded on power up. The parameters that are saved include the thirteen (13) settings listed on the 'EDIT SCREEN' and all the current printer parameters listed on the 'PRINTER SCREEN' page.

Any editing done on a parameter in a program is automatically saved.

The label sensor setting is local and not controlled by the PLC. The label sensor adjustment, once set, is fixed until readjusted using the same procedure (pages 3.16 and 3.17). The label sensor may need to be readjusted if labels or backing paper have a significant change in color.

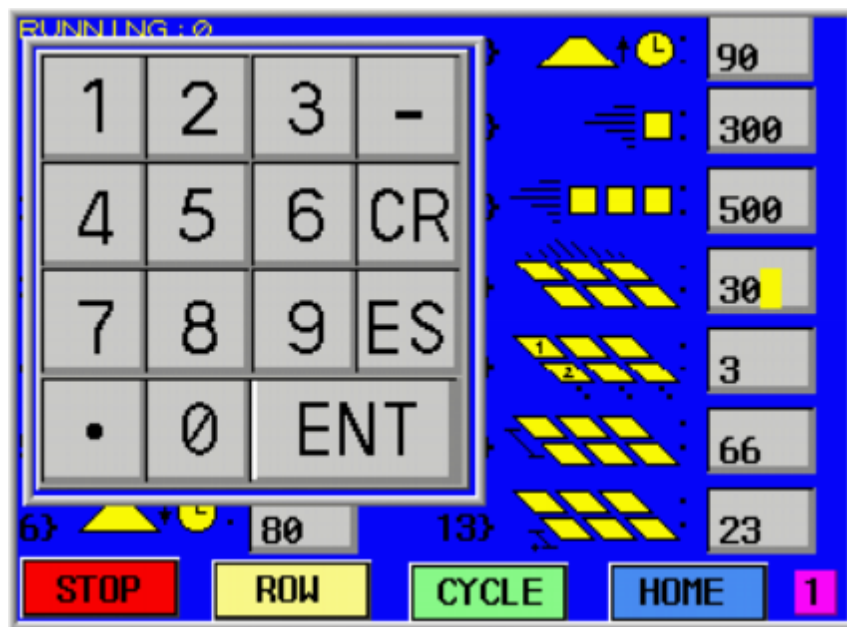

## Name Program Touchscreen

This screen displays the current names of all sets of operating parameters (programs). To change a name, press the file number and enter a new name. The name can be up to thirteen (13) characters in length.

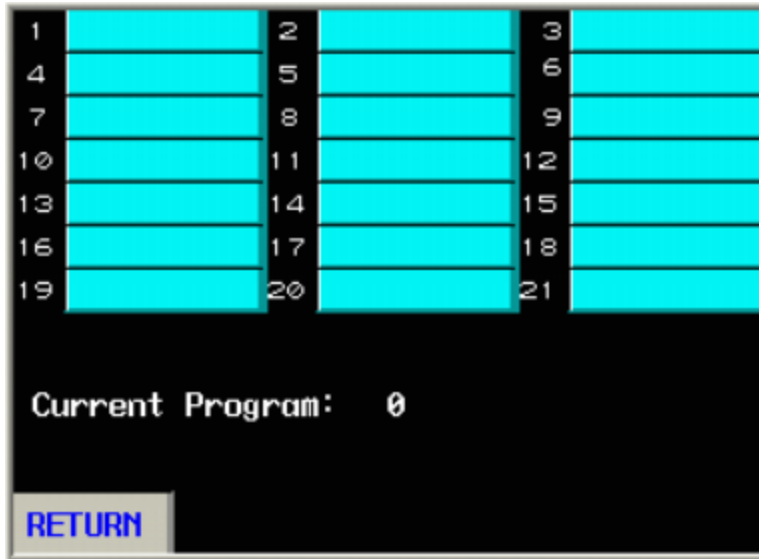

## Load Program Touchscreen

This screen displays the current sets of operating parameters (programs). To load a program into current operation, press the file number/name and the system will immediately start operating with those parameters.

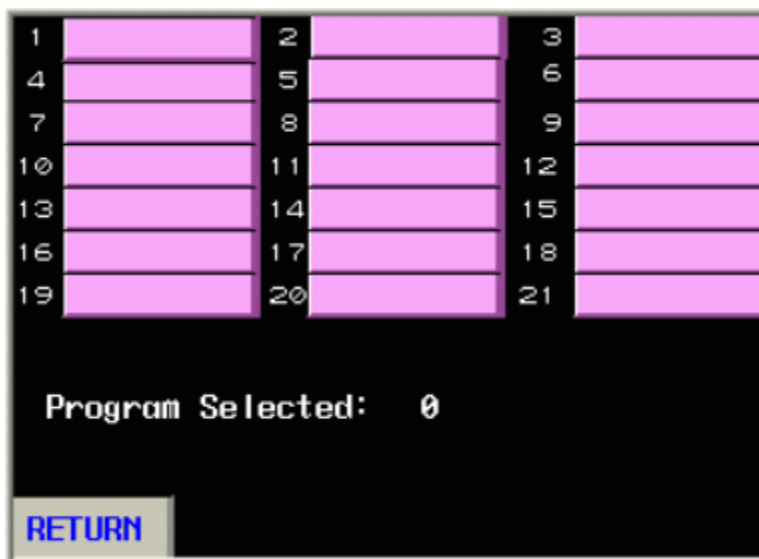

## Security Touchscreen

The Matrix™ Crossweb Package Labeler control has a two-level security system. A separate password is entered for each level. Once entered, the system will grant full access to all functions permitted at that level until the system is powered off. After a power up, the codes must be entered to regain access.

- **LEVEL-1 PASSWORD:** Allows operators to change the thirteen (13) basic operating parameters. The initial password is '456.'
- **LEVEL-2 PASSWORD:** Allows the maintenance personnel to gain access to the maintenance screens for options, testing, and setup. The LEVEL-1 password can be turned ON or OFF at this level (see MAINTENANCE screen). The initial password is '789.'
- **LEVEL-3 PASSWORD:** The Level 3 password is reserved for factory trained service technicians.

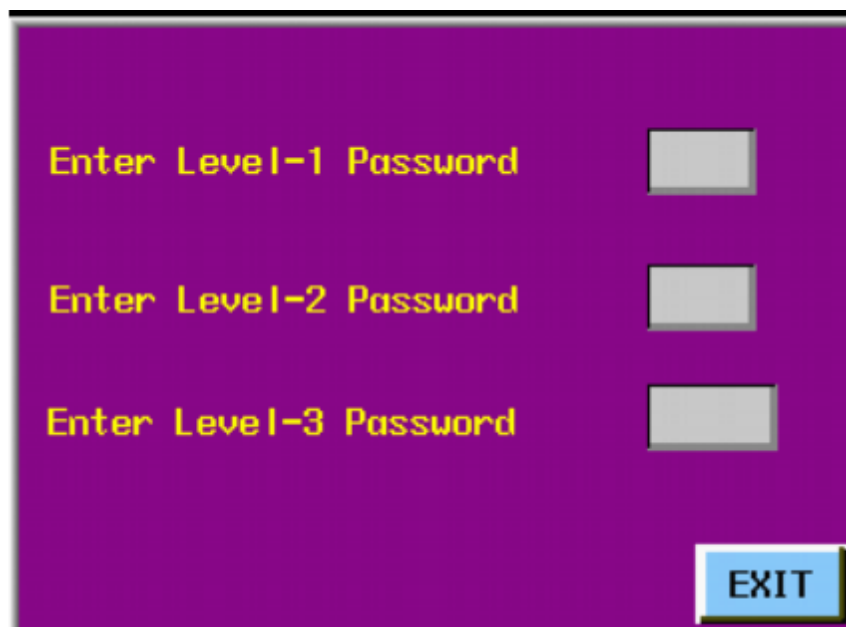

### NOTE:

1. Loading a different program does not require any security level access.
2. The passwords can be changed in the Maintenance section, see pages 4.20 and 4.32.

# SICK Label Sensor Setup

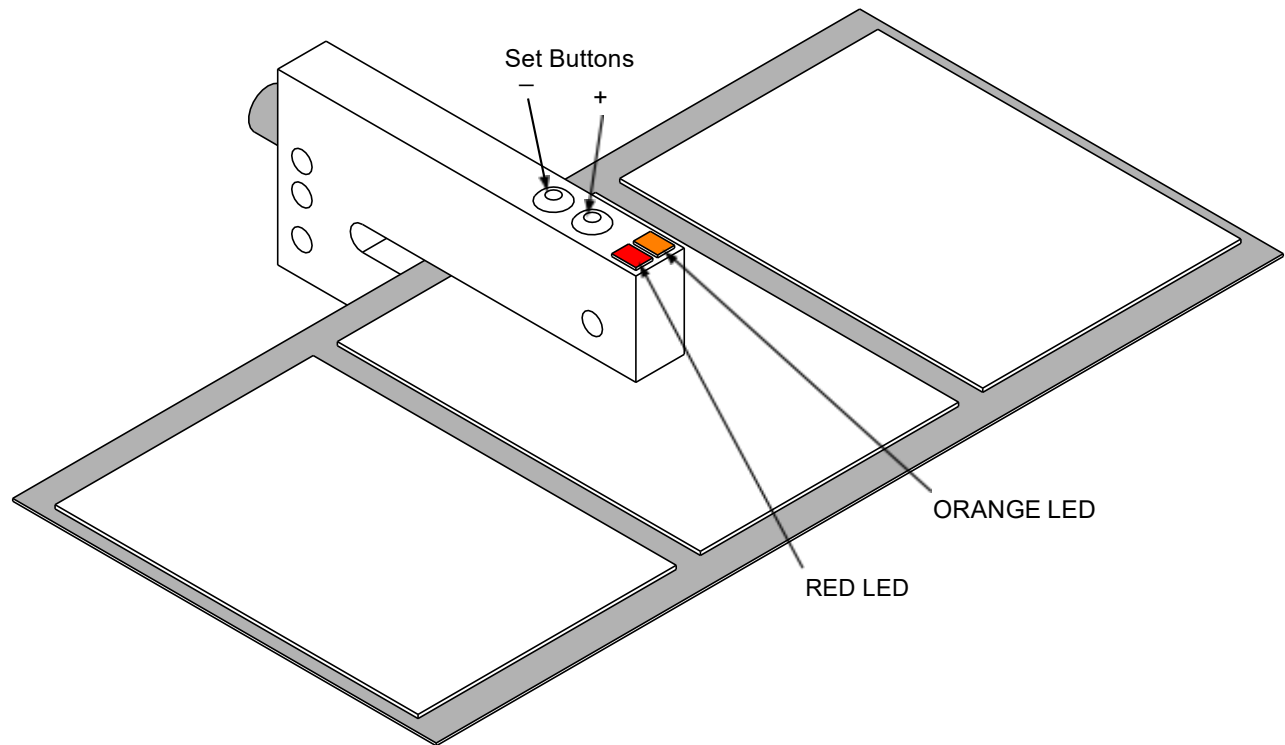

1. Power up machine.
2. Place backing paper only into the sensor slot.
3. Press and hold the “-” set button until the RED LED flashes and the ORANGE LED turns OFF.
4. Press and hold the “+” set button until the RED LED flashes and hold until the ORANGE LED just turns ON.
5. Release the “+” set button.
6. Test the sensor by passing the label gap in and out of the sensor, the ORANGE LED should only turn ON in the gap and off as the label is passed through the sensor.
7. Sensor is ready for operation.

## Locking/Unlocking

If the set buttons are pressed for three seconds and released, the sensor will become locked and the RED LED will remain illuminated. To unlock the sensor, press the set buttons for three seconds and the RED LED should turn off.

## Reversing Logic

If the set buttons are pressed for six seconds and released, the sensor will reverse logic and the ORANGE LED will remain illuminated over labels instead of over the backing paper. To change the logic back to the correct state, press the set buttons for six seconds and the ORANGE LED should only illuminate over the backing paper.

## Clear Label Setup

1. Make sure the sensor is mounted and connected to the labeler and power is turned ON. See Section 5, Cable Schematics for connection locations.
2. Insert labels and backing paper into the sensor slot and over the sensor's mark, located on each side of the sensor.
3. Hold the labels and backing paper in the sensor, press, and release the button on the sensor. The GREEN LED will flash.
4. Manually pull the labels and backing paper so that five (5) to ten (10) label gaps pass through the sensor slot.
5. Press and release the button. The GREEN LED will remain ON.
6. The sensor is now ready for use.

**NOTE:** The sensor should operate with a wide variety of labels and rarely requires readjustment.

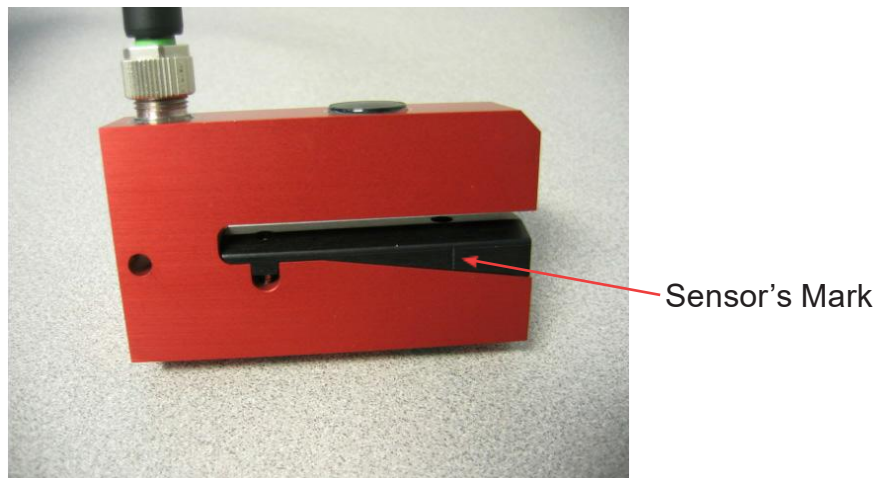

# MAINTENANCE

## Prior to Cleaning

Every environment and application is different; therefore, UltraSource LLC cannot provide cleaning instructions to guarantee microbiological sanitation. UltraSource requests that the owner of this machine consult with sanitation experts to review the unit working in their particular environment to develop a robust cleaning schedule and methodology, followed by bacterial testing to ensure satisfactory cleaning procedures are followed.

**NOTE:** Use a detergent/sanitizer that will not degrade stainless steel or plastic. The labeler may be rinsed using a low pressure spray only. The control cabinet should be wiped clean and no water spray should be directed toward it.

### **⚠ CAUTION**







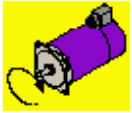

*Cleaning agents.*

*Do not get the cleaning agents in eyes, on skin, or on clothing. Always wear rubber gloves, goggles, and protective clothing when contact is likely. Consult product manufacturer for specific details.*

## Cleaning Instructions

Turn off main power switch and disconnect air supply (or turn down to zero using regulator), remove air line at the tamp cylinder, remove tamp cylinder cable at the cylinder, and disconnect fan cables. Then remove the upper section of the tamp unit (including tamp blades). The tamp blades can then be dipped into a solution of cleaner and water, but do not submerge the fans directly.

# Maintenance Screen

	MOVE MOTOR 1	Press to test run label head motor
	MOVE MOTOR 2	Press to test run transporter motor
	MOVE MOTOR 3	Press to test run shift motor <b>Caution:</b> Be sure the labeler can move freely 250mm in each direction
	I/O SCREEN	Press to enter I/O test screen. See page 4.21.
	ALL MOTORS	Press to stop motor test
	COPY PROGRAM	Press to copy programs <b>Caution:</b> Destination program will be overwritten. See page 4. 21.
	OPTIONS:	Press to enter options screen. See page 4.22.
	PASSWORD	Press to change passwords. See page 4.32.
	EXIT	Returns to main screen

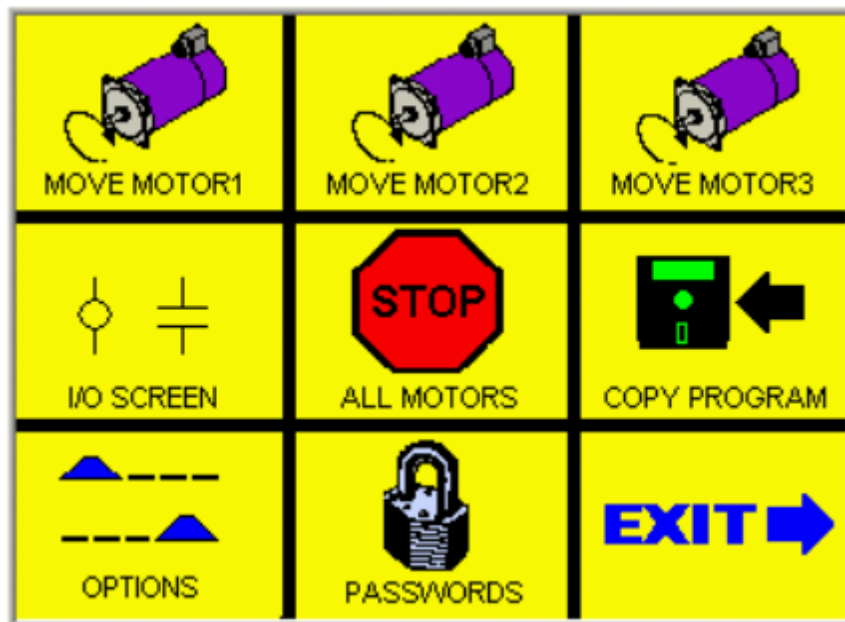





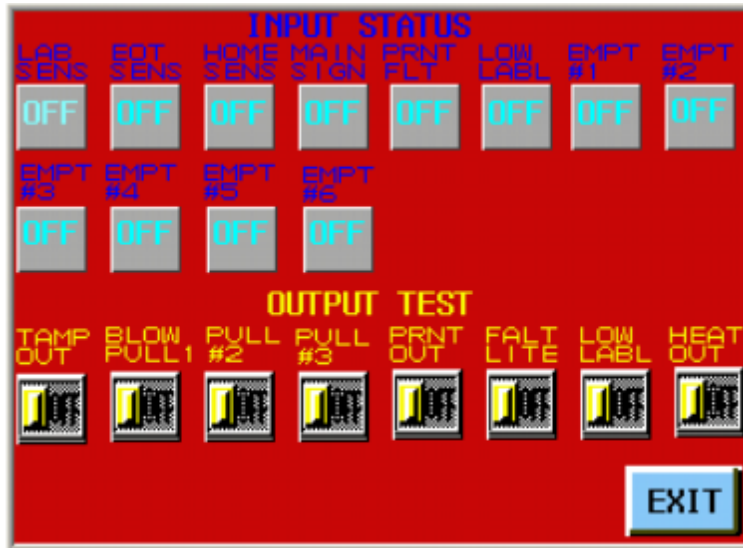

## I/O Screen

All input status indicators are displayed on the screen as shown. Input status is also indicated by RED LEDs on the front edge of the motion control card.

Each output can be tested by pressing and holding the individual button. All outputs are also indicated by RED LEDs on the PCB in the control cabinet.

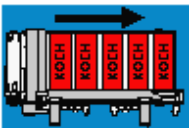

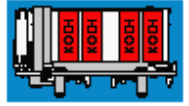
# Options Screen

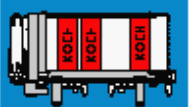
	PREDISPENSE	Press to set predisperse screen. See page 4.23.
	OPTIMIZE	Press to set shift optimized screen. See page 4.23. (Applies to shifting package labelers.)
	NON-STOP	Press to set non-stop high-speed operation. See page 4.24.
	HEAD-TO-HEAD	Press to set head-to-head label operation. See page 4.25.
	OPTIONS	Press to go to miscellaneous options. See page 4.26.
	NON-STANDARD PLACEMENT	Press to set custom spacing operation. Allows for non-symmetrical spacing up to a total of six labels across the machine. See page 4.29.
	LOW LABEL	Press to set low label detection operation. See page 4.31.
	EMPTY PACKAGE	Press to set empty package detection operation. See page 4.31.

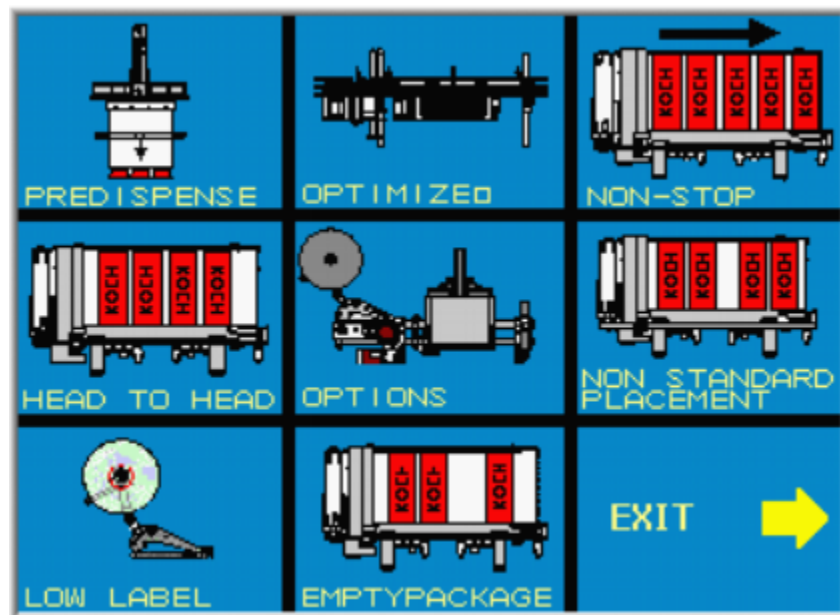

## Predispense Screens

In the **PREDISPENSE MODE**, the labeler will predispense the first row of labels before the labeling signal is received and tamp the first row immediately when the signal is received. This will speed up operation of the labeler.

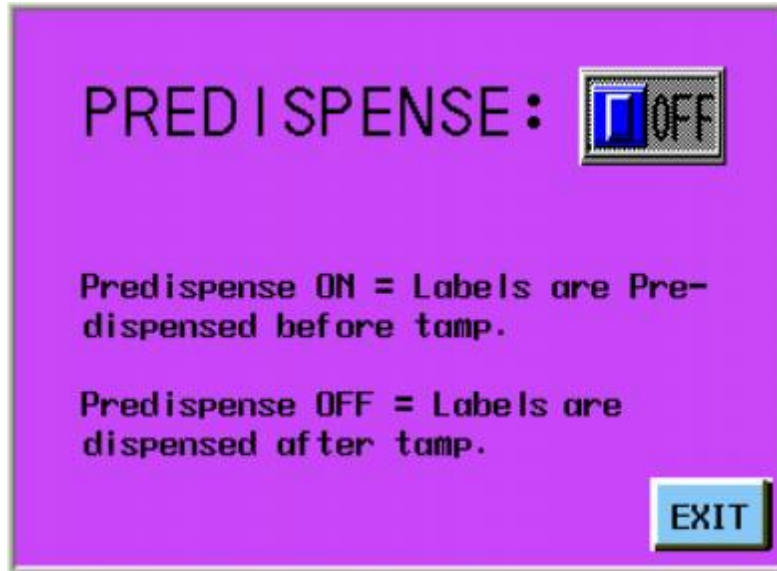

## Optimize Shift Screen

In the **OPTIMIZED MODE**, a shifting-type package labeler will not return to home every cycle. In the non-optimized mode, the labeler will go to the home position after each cycle. Operating in the optimized mode will also speed up the labeler operation.

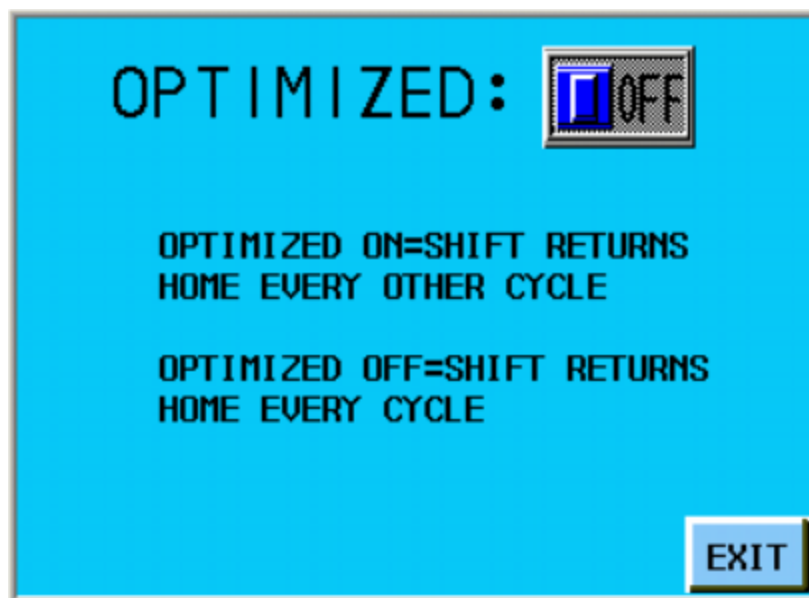

## Non-Stop Screen

(patent pending)

Non-Stop operation is for high-speed applications. Each row of labels are dispensed in a single dispense cycle. This is a global parameter; it is not stored by program. The peel over may need to be readjusted after turning this feature ON.



The NON-STOP option (patent pending) will dispense all labels for a given row without stopping between labels, resulting in a significant speed increase. When this option is selected, the transporter speed parameter will be removed, as this parameter is now internally calculated. This option is only available on Matrix™ Crossweb Package Labelers and cannot be used with the following other options:

- Date Code Printing (except Ink Jet/Laser options)
- Head-to-Head Labeling
- Random Spacing

# Head-to-Head Screens

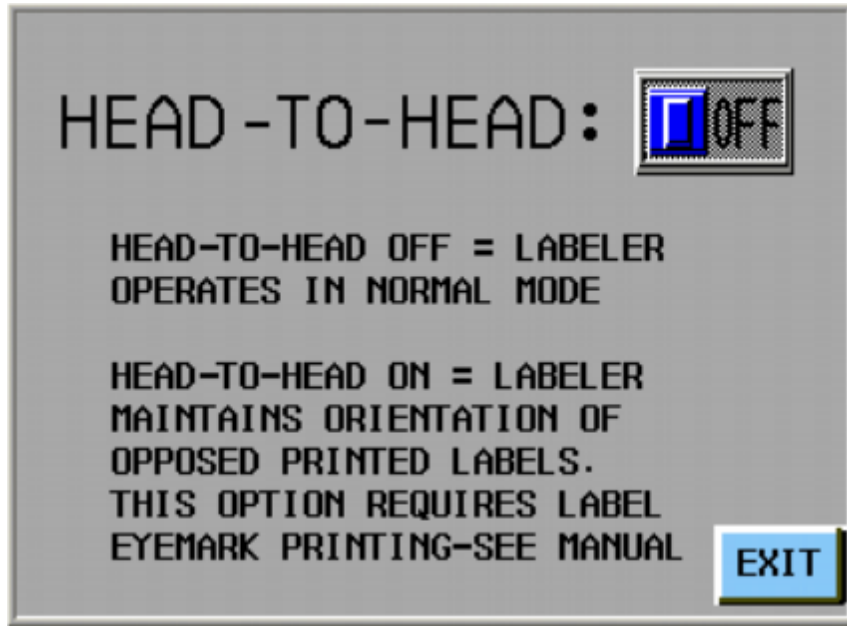

The **HEAD-TO-HEAD** option keeps sets of head-to-head printed labels synchronized. **NOTE:** This option requires a label sensor blocking mark be printed on the backing material between label sets.

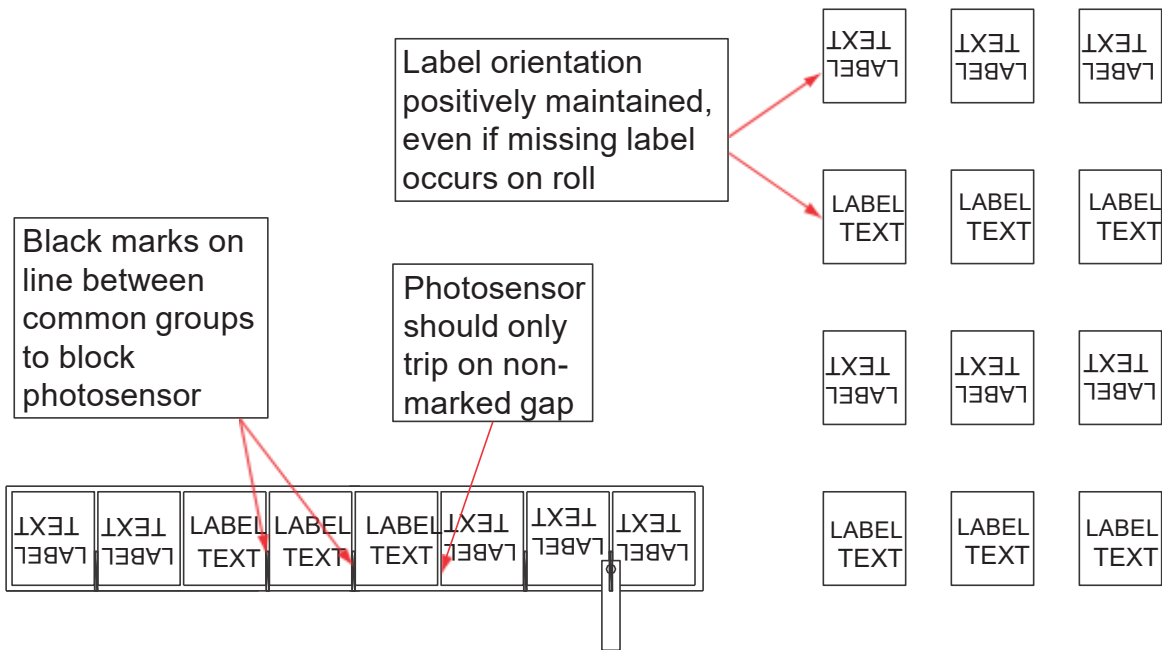

# Miscellaneous Options, Page 1

POWER UP RUN/ STOP	Sets whether system will power up in the RUN or STOP mode
CLOSED LOOP	Sets closed loop (or busy) signal using fault output signal
LABEL SENSOR LOGIC	Reverses label sensor logic
MAIN SIGNAL LOGIC	Normally open labeler starts on make to break Normally closed labeler starts on break to make
FILM/PACK AGE CONFIGURATION	Sets Film Labeler or Package Labeler configuration
CONTRAST	Adjusts screen contrast
AXIS	Sets number of motors (2 or 3) Setting for shifting package labeler is 3
PULL UP DROP DE LAY	Adds delay to pull up release (for Film Labeler only)
LABEL ACCELERATION	Adjusts label/transporter acceleration rate in mm/s <sup>2</sup> Standard Motor: 12000; High-Torque: 15000; Super-Torque: 18000
SHIFT ACCELERATION	Adjusts shift acceleration rate in mm/s <sup>2</sup> Standard Motor: 1500; High-Torque: 2000; Super-Torque: 2500
STEP/SERVO	Selects stepper or servo option on shift motor
CYCLES	Total machine cycle counter, press to reset
PAGE 2	Continued Miscellaneous Options

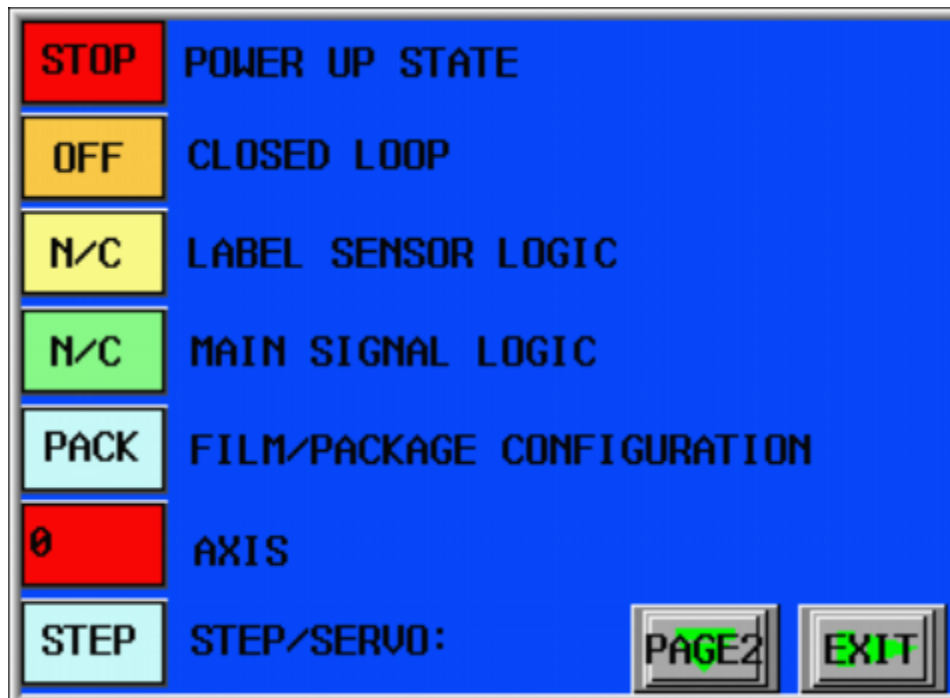

## Miscellaneous Options, Page 2

PULL UP DROP DE L A Y	Adds delay to pull up release (for Film Labeler only)
LABEL ACCELERATION	Adjusts label/transporter acceleration rate in mm/s <sup>2</sup> Standard Motor: 12000; High-Torque: 15000; Super-Torque: 18000
SHIFT ACCELERATION	Adjusts shift acceleration rate in mm/s <sup>2</sup> Standard Motor: 1500; High-Torque: 2000; Super-Torque: 2500
LABEL GAP	Can be adjusted for special options
SIMULTANEOUS PULL UP CYCLES	FILM LABELER ONLY. Fires pull up #1 and #2 together for longer index
PAGE 3	Total machine cycle counter, press to reset
	Continued to Language Option

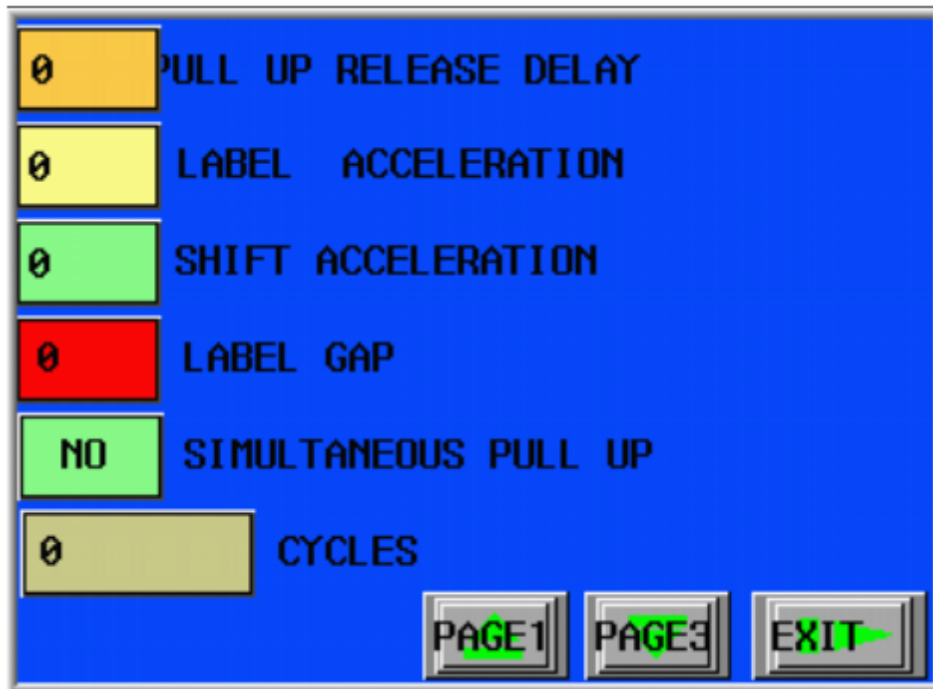

## Language Option, Page 3

LANGUAGE Select flag of country for desired language displayed



## Change Parameter Instructions

The miscellaneous options editing screen is shown below. This allows the user to edit all of the parameters seen on page 4.26 and 4.27. The labeler will be interrupted during the editing process. When the Matrix™ Labeler is powered down, the current parameters are stored in non-volatile memory and are automatically reloaded on power up. These parameters are global and will apply to all programs.

1. Touch the desired parameter's box.
2. A yellow cursor will flash on the selected number and a keypad will be displayed to enter the value desired.
3. After entering value, press the ENT button.
4. After pressing the ENT button, the system will automatically save the value.
5. Press the EXIT button to return to the MAIN menu.

**NOTE:** Labeler is not equipped with the servo option at this time.

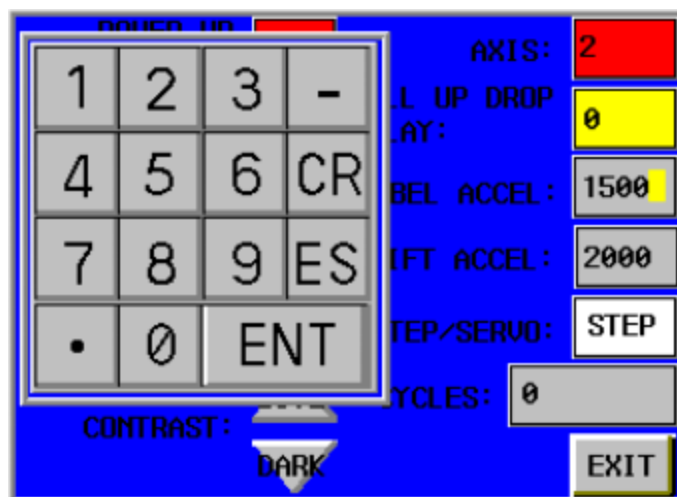

## Non-Standard Placement

The Non-Standard Placement screen is shown below. This allows the user to select multiple spaces or multiple offsets and to turn the options ON/OFF. Multiple spaces will allow the user to edit for up to eleven (11) spaces or twelve (12) individual labels. Multiple offsets will allow the user to edit for up to ten (10) offsets. The labeler will be interrupted during the editing process.

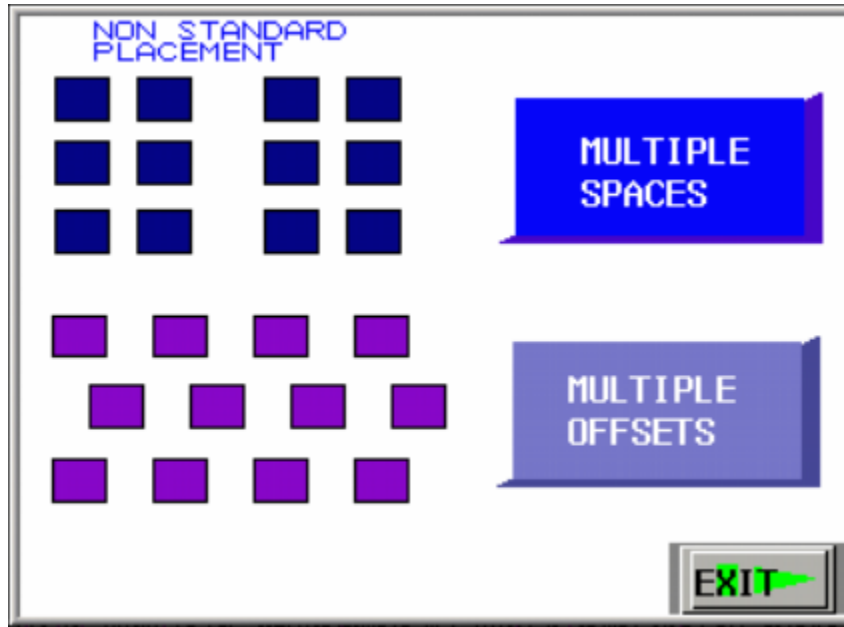

**NOTE:** See page 4.30 for editing of multiple spaces and multiple offsets.

## Multiple Spaces Editing

1. Touch the desired parameter's box.
2. A yellow cursor will flash on the selected number and a keypad will be displayed to enter the value in millimeters desired.
3. After entering value, press the ENT button.
4. After pressing the ENT button, the system will automatically save the value.
5. Press the EXIT button to return to the MAIN menu.



## Multiple Offsets Editing

1. Touch the desired parameter's box.
2. A yellow cursor will flash on the selected number and a keypad will be displayed to enter the value in millimeters desired.
3. After entering value, press the ENT button.
4. After pressing the ENT button, the system will automatically save the value.
5. Press the EXIT button to return to the MAIN menu.



## Low Label Detection

LOW LABEL DETECTION will detect a low label roll on the label reel. The labeler will detect a low label roll and display a warning on the touchscreen. At this time the labels can be spliced together to avoid re-threading of the label head and slowed production.

**NOTE:** This option requires a hardware (p/n 868586) and sensor kit (p/n 865068).



## Empty Package Detection

EMPTY PACKAGE DETECTION will detect empty packages one row upstream of the labeler and will only place labels when product is present. This option is available for up to six (6) lanes. The labeler can be left in the ON state and it will automatically start and stop labeling when product is detected.

**NOTE:** This option requires a hardware (p/n 868586) and sensor kit (p/n 865068).

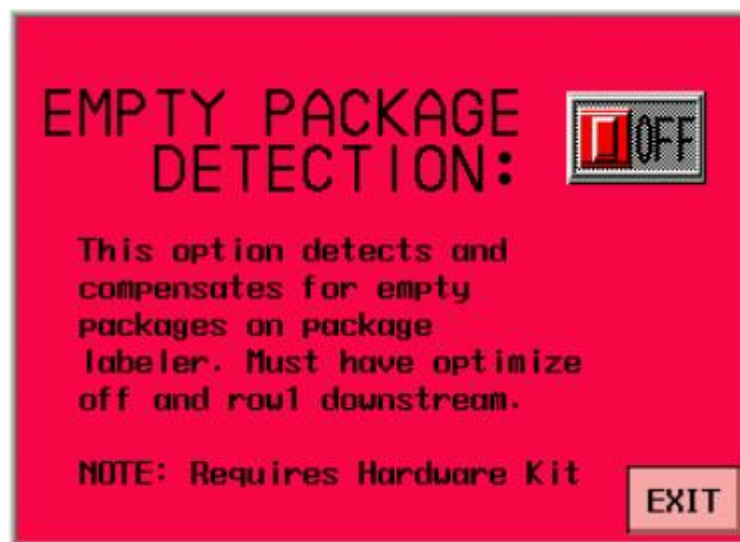

## Passwords

This screen will allow the entry of new three-digit passwords.

The option for locking out the operator to edit parameters is set default to OFF. If it is turned ON, basic parameter editing will require the proper entry of either a LEVEL-1 or LEVEL-2 password, if EDIT screen protection is turned ON, the operator will only be able to load programs and start/stop the machine.

EDIT SCREEN PROTECTED:

ENTER LEVEL-1 PASSWORD: 0

ENTER LEVEL-2 PASSWORD: 0

WARNING: THESE PASSWORDS ONCE SET  
ARE NON-RETRIEVABLE

EXIT

**NOTE:** If the passwords are forgotten, the maintenance screen can be re-entered by going into the Label sensor set screen and touching the upper left corner of the screen.

# Servo Safety

This screen appears when the safety switch on the servo motor option has been tripped by lifting the servo motor safety guard or disconnecting the switch.

This safety feature was added to protect the operator from the movement of the labeler head due to the rapid movement and the potential ability for pinch point hazards. The machine will continue to be in motion after the servo safety guard has been lifted due to momentum carried by the labeler head. When the safety is reset, the labeler head will advance to the 'Home' position and the labeler will be ready for 'Run' mode.

**⚠ WARNING** *Moving parts. Pinch point hazard.  
Do not put hands into machine while running.*

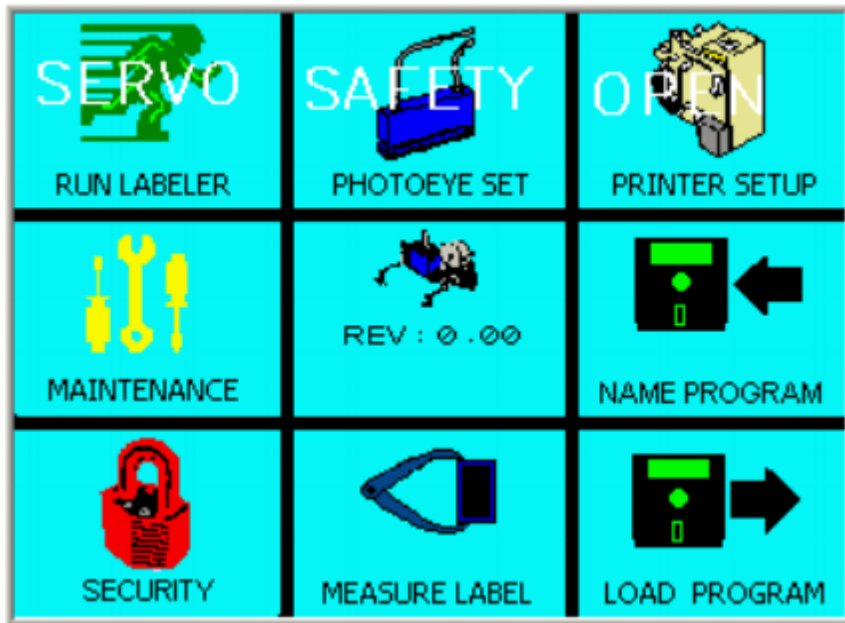

## Maintenance Log

A maintenance log is a journal of all maintenance performed. Each entry includes a date, maintenance performed (details about the type of work done), and technician (who performed the maintenance). The maintenance log is also a place where a schedule is kept for further maintenance.

A maintenance log will clearly show daily inspections, tamp blade replacement, and so on. A master copy has been provided on page 4.35, please create a copy and store in the back of this owner's manual.

## Service Log

A service log is a journal of all service work performed. Each entry includes a date, service provided (details about the type of service), and technician (who performed the service).

A service log will clearly show training provided, frequent wear items, and so on. A master copy has been provided on page 4.36, please create a copy and store in the back of this owner's manual.





# SCHEMATICS

## Stepper Drive Resistor Locations

Motor Assembly Part No.	R1 Value in Ohms (UltraSource Part No.)	R2 Value in Ohms (UltraSource Part No.)
895020 Super-Torque (White Motor Body)	40.2Ω (869401)	357Ω (869415)
895022 High-Torque (Burgundy Motor Body)	80.6Ω (869402)	324Ω (869414)
895023 Low-Torque (Black Motor Body)	121Ω (869403)	280Ω (869413)
866986 Stepper (Transport)	162Ω (869404)	243Ω (869412)
866171 Stepper (Transport)	200Ω (869411)	200Ω (869411)

Connect the drive appropriate resistors (R1 and R2) to the designated pin terminal. Resistor 1 will connect to GND and AIN pin terminals. Resistor 2 will connect to AIN and +5V pin terminals. See the diagram to the right on the stepper drive. R1 and R2 will share the AIN pin terminal.

**NOTE:** These resistors will load the appropriate motor parameters into the drive.

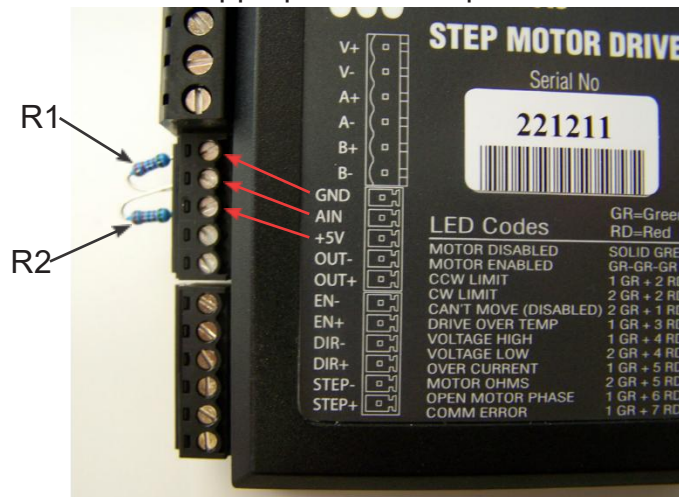

# Main Control Box Schematic

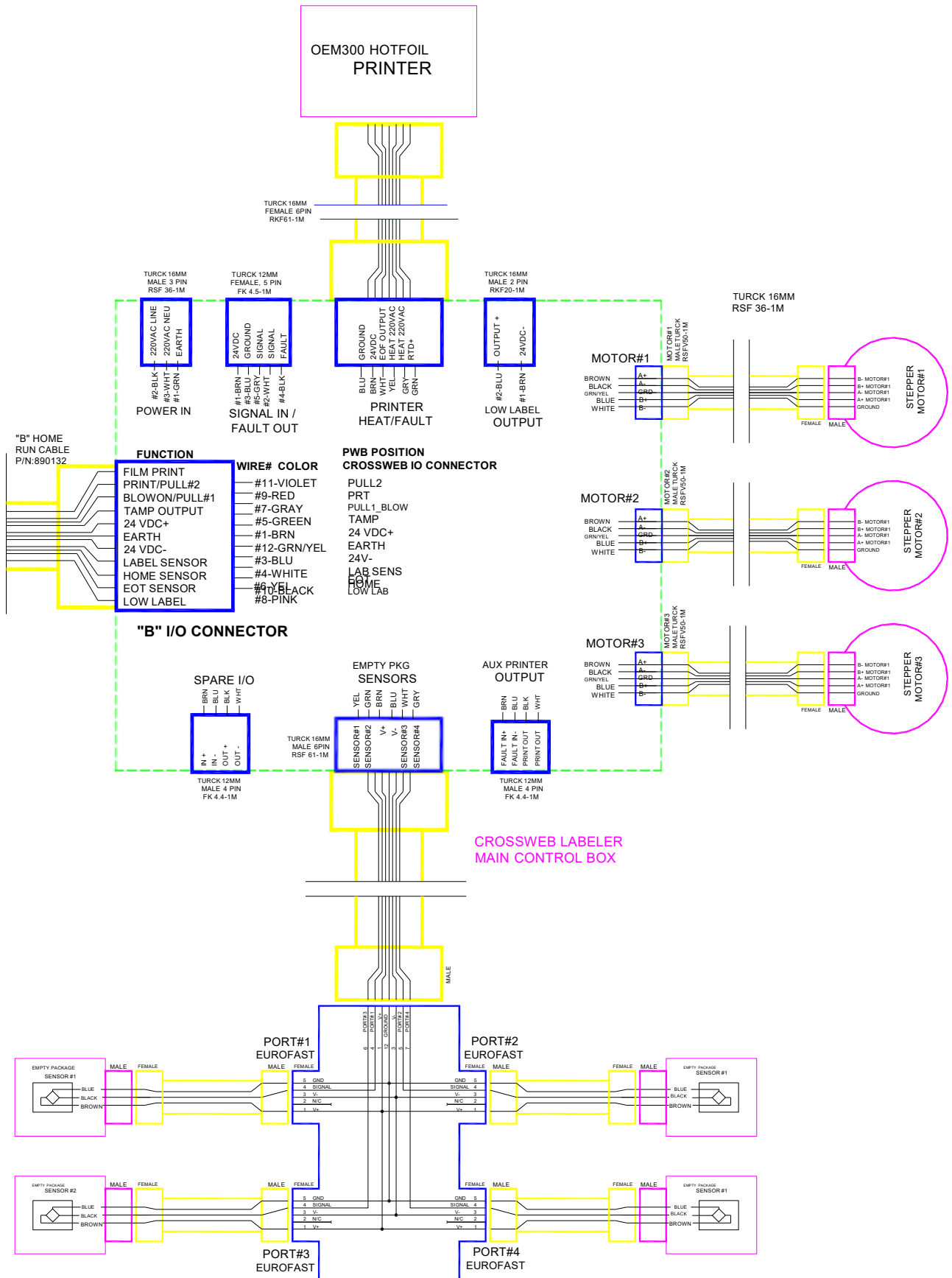

# Junction Box Cable Schematic

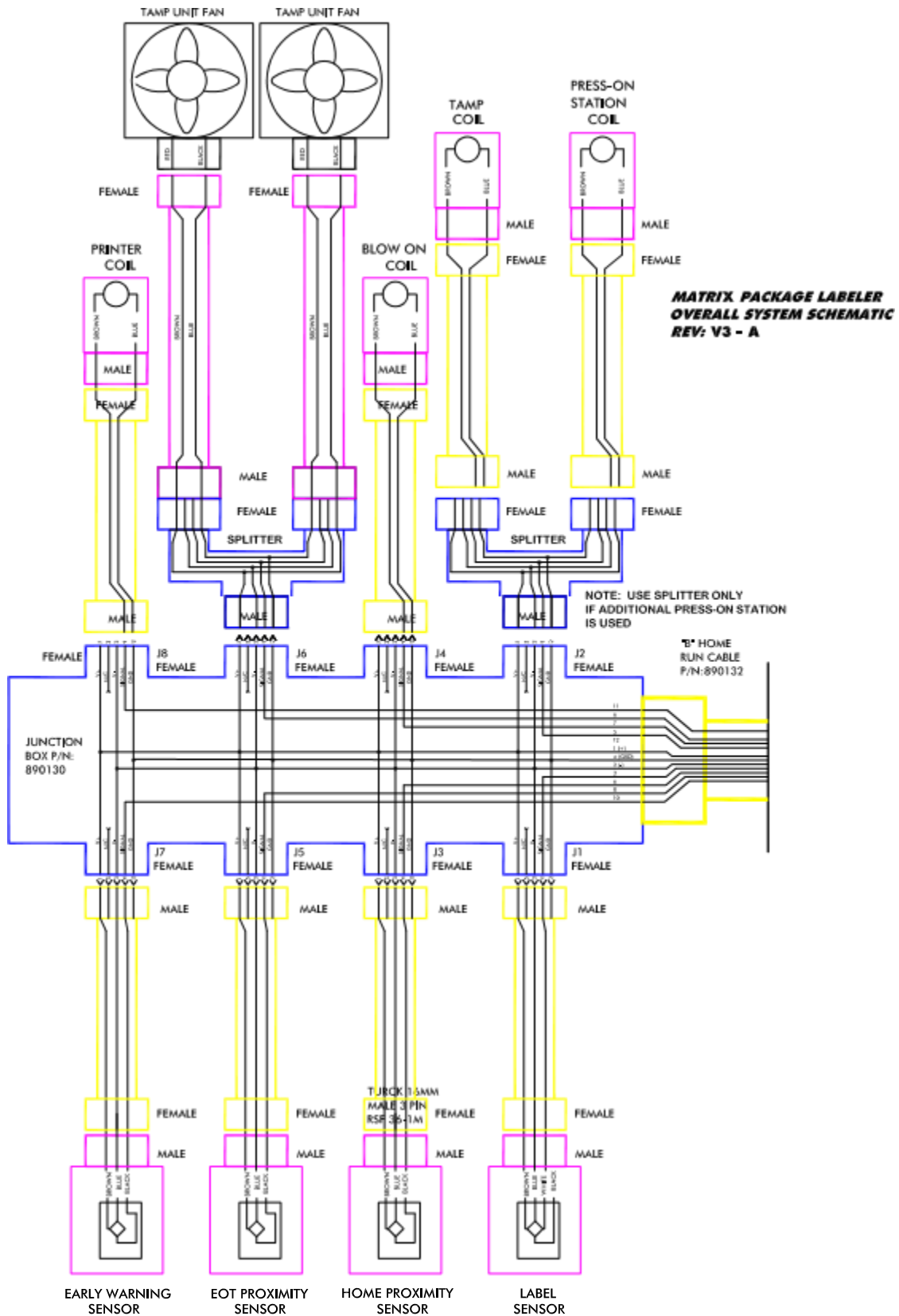

# Labeler Signal Diagram

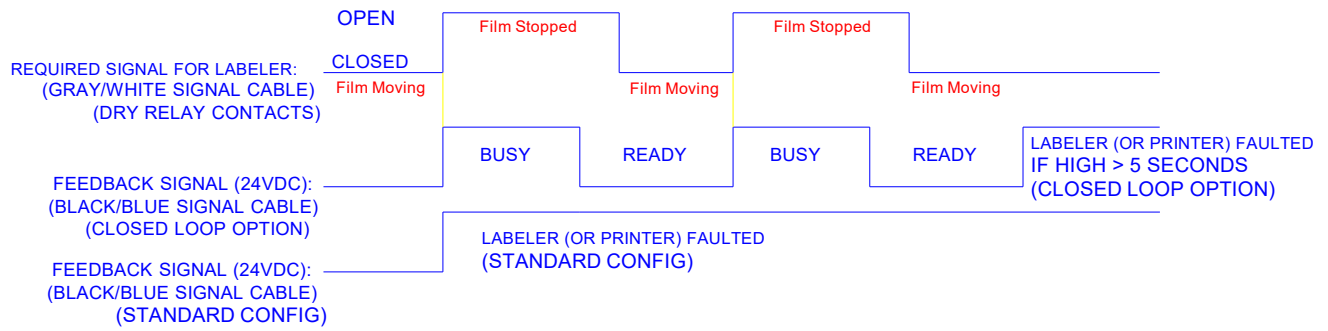

REMAINDER OF THIS PAGE LEFT BLANK INTENTIONALLY.

# Schematics Layout

## SCHEMATIC VIEW 1

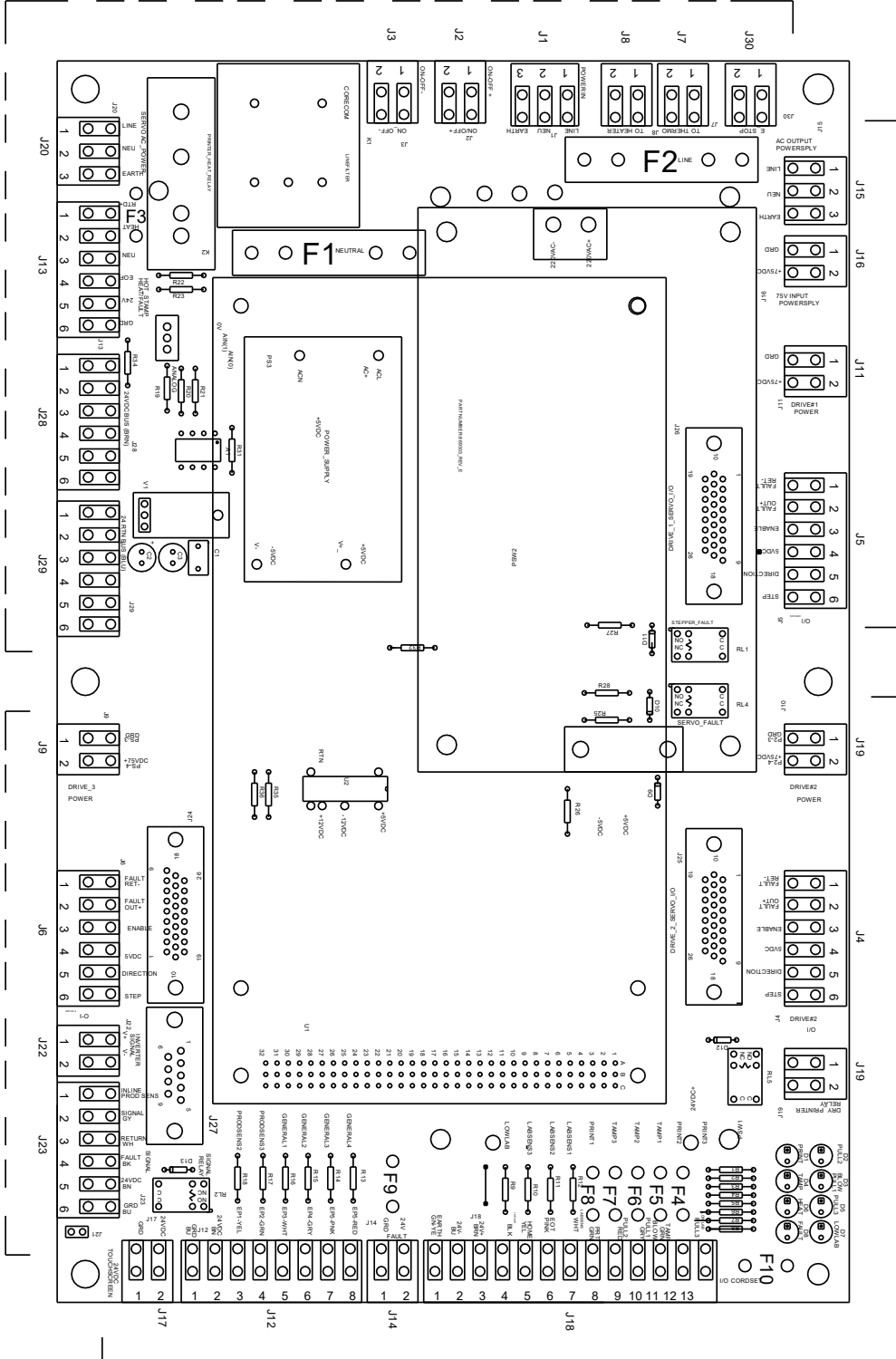

SCHEMATIC VIEW 1

SCHEMATIC VIEW 2

SCHEMATIC VIEW 4

SCHEMATIC VIEW 3

FUSE TABLE		
FUSE#	APPLICATION	SIZE
F1	CROSSWEB	3A
F1	INLINE	5A
F2	CROSSWEB	3A
F2	INLINE	5A
F3	ALL	3A
F4	ALL	3A
F5	ALL	3A
F6	ALL	3A
F7	ALL	3A
F8	ALL	3A
F9	ALL	3A
F10	ALL	3A

## SCHEMATIC VIEW 3

# Stepper Schematics, View 1

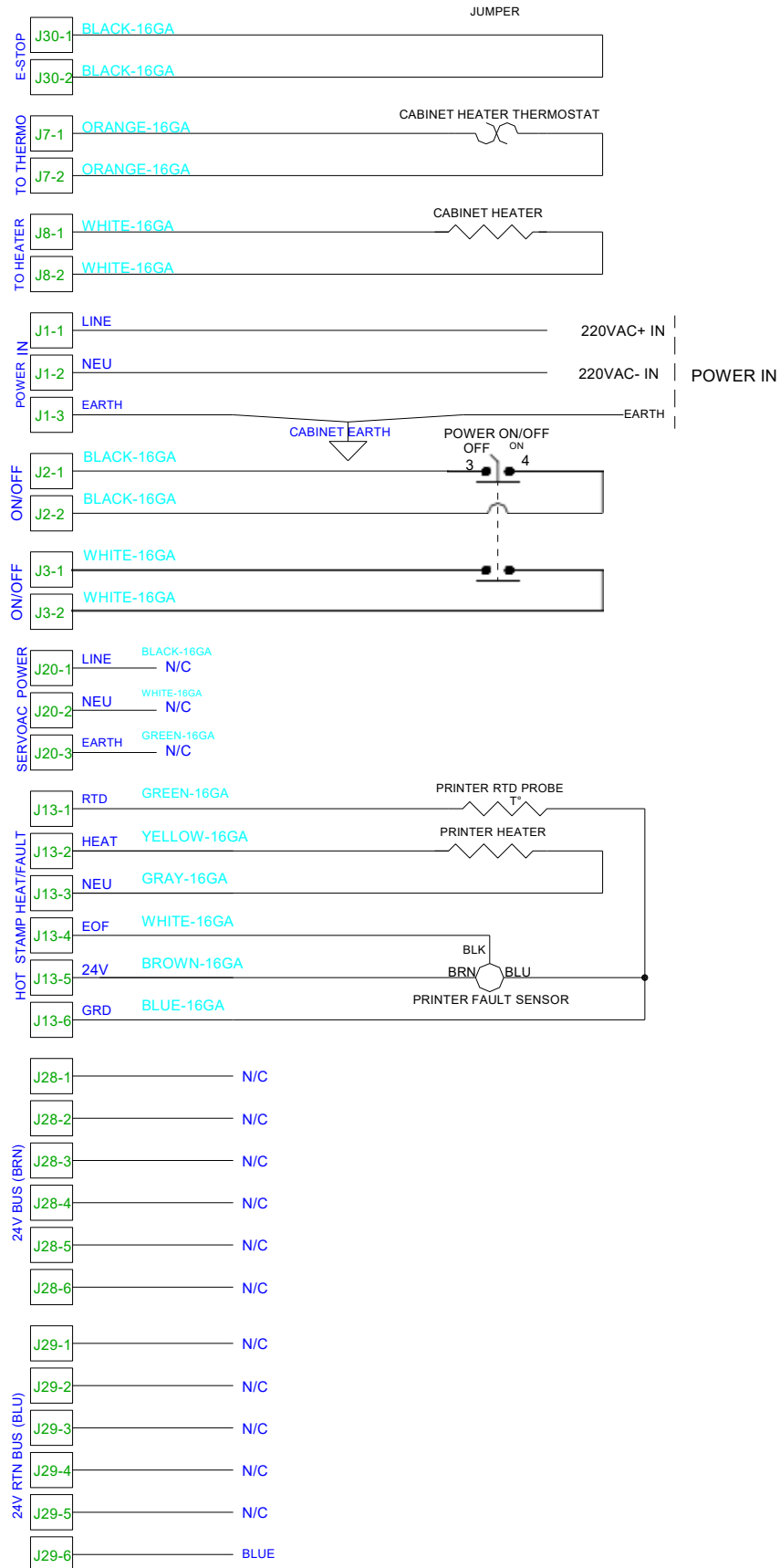

# Stepper Schematics, View 2

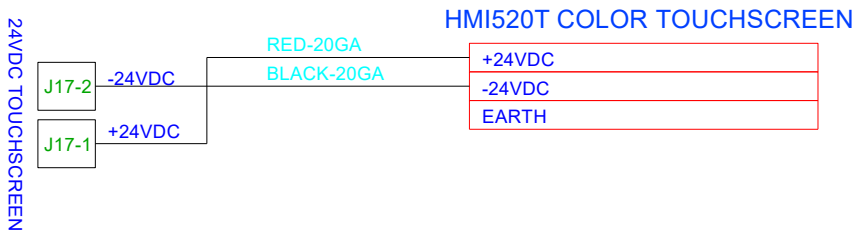
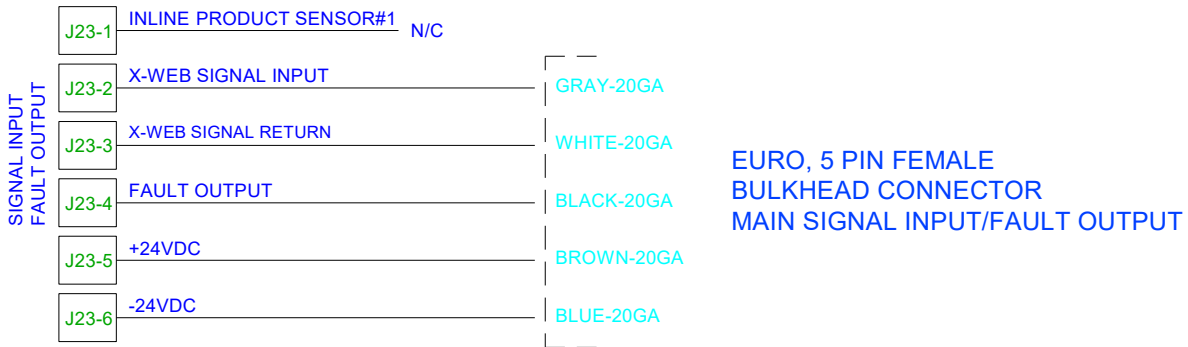
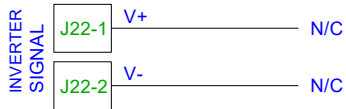
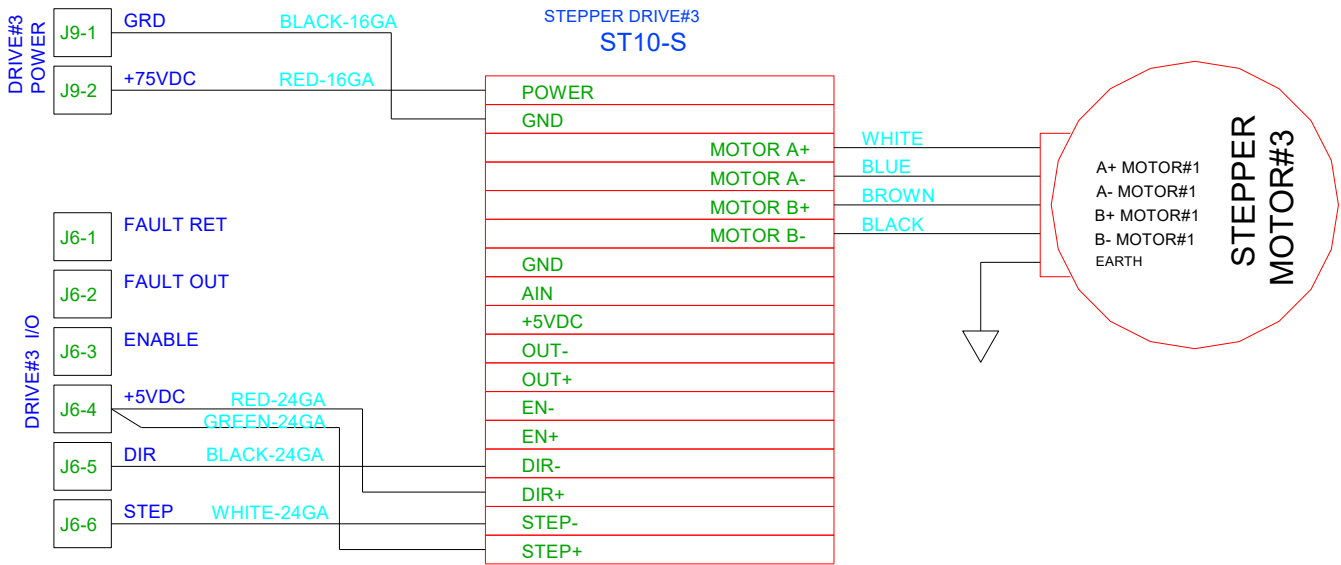

# Stepper Schematics, View 3

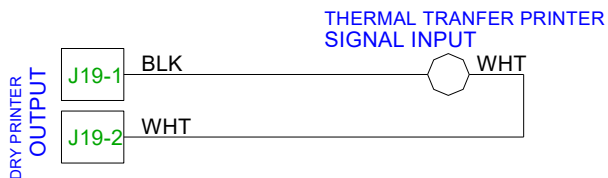
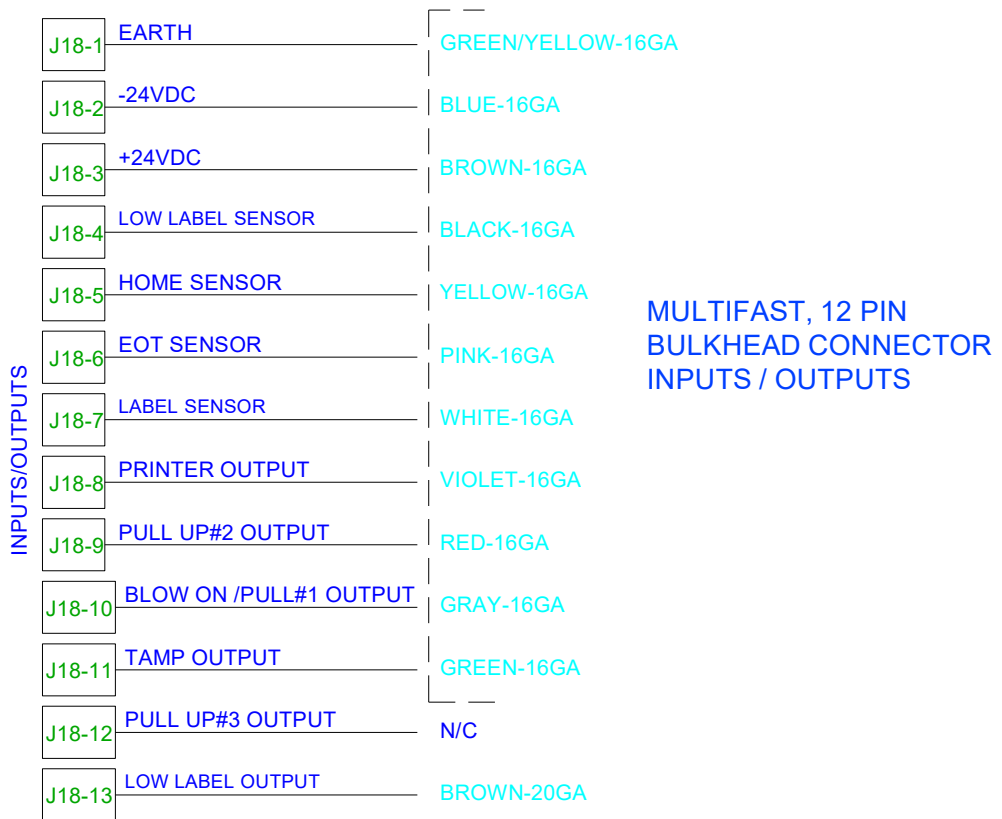
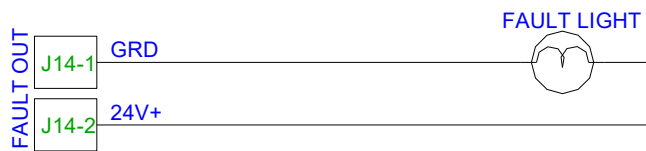

# Stepper Schematics, View 4

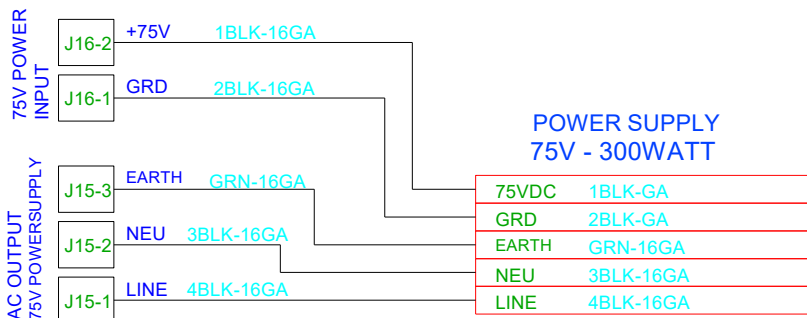
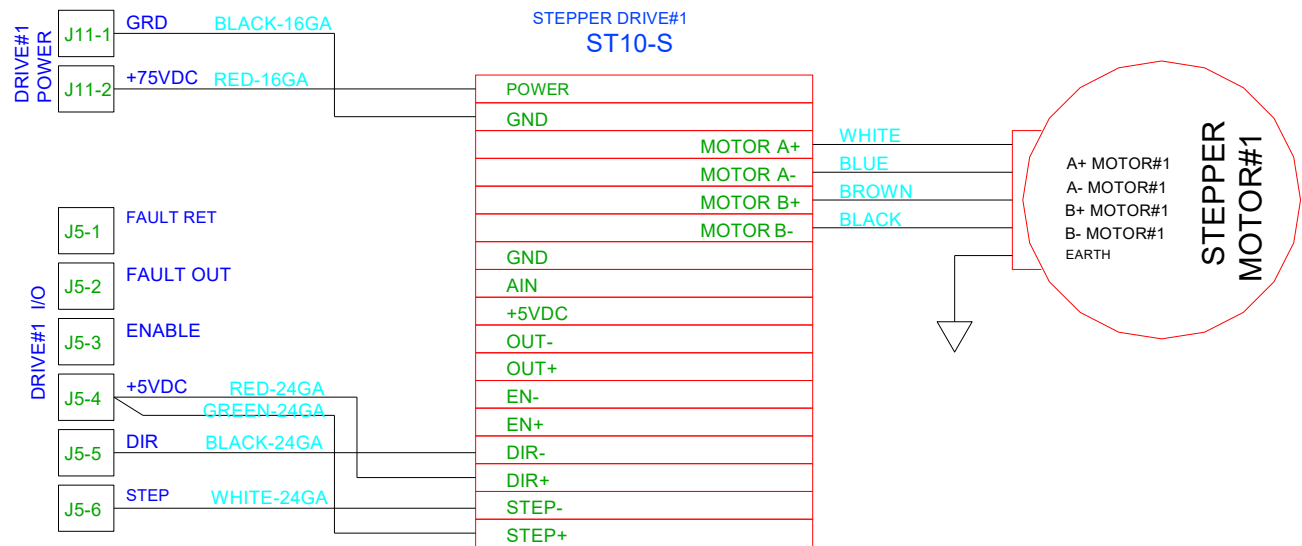
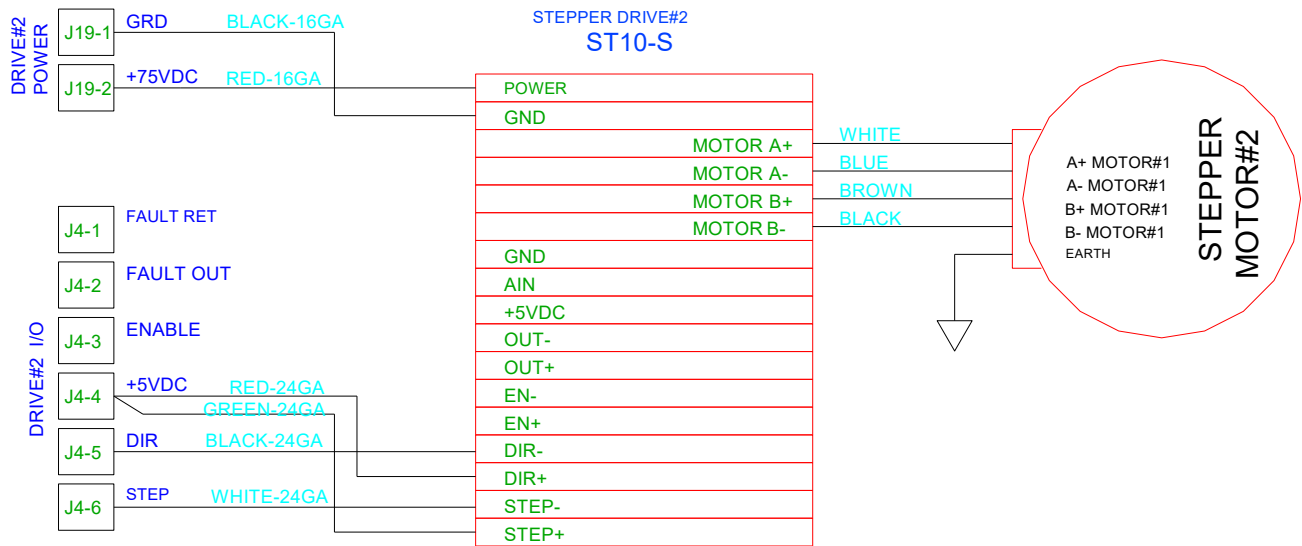

# Servo Schematics, View 1

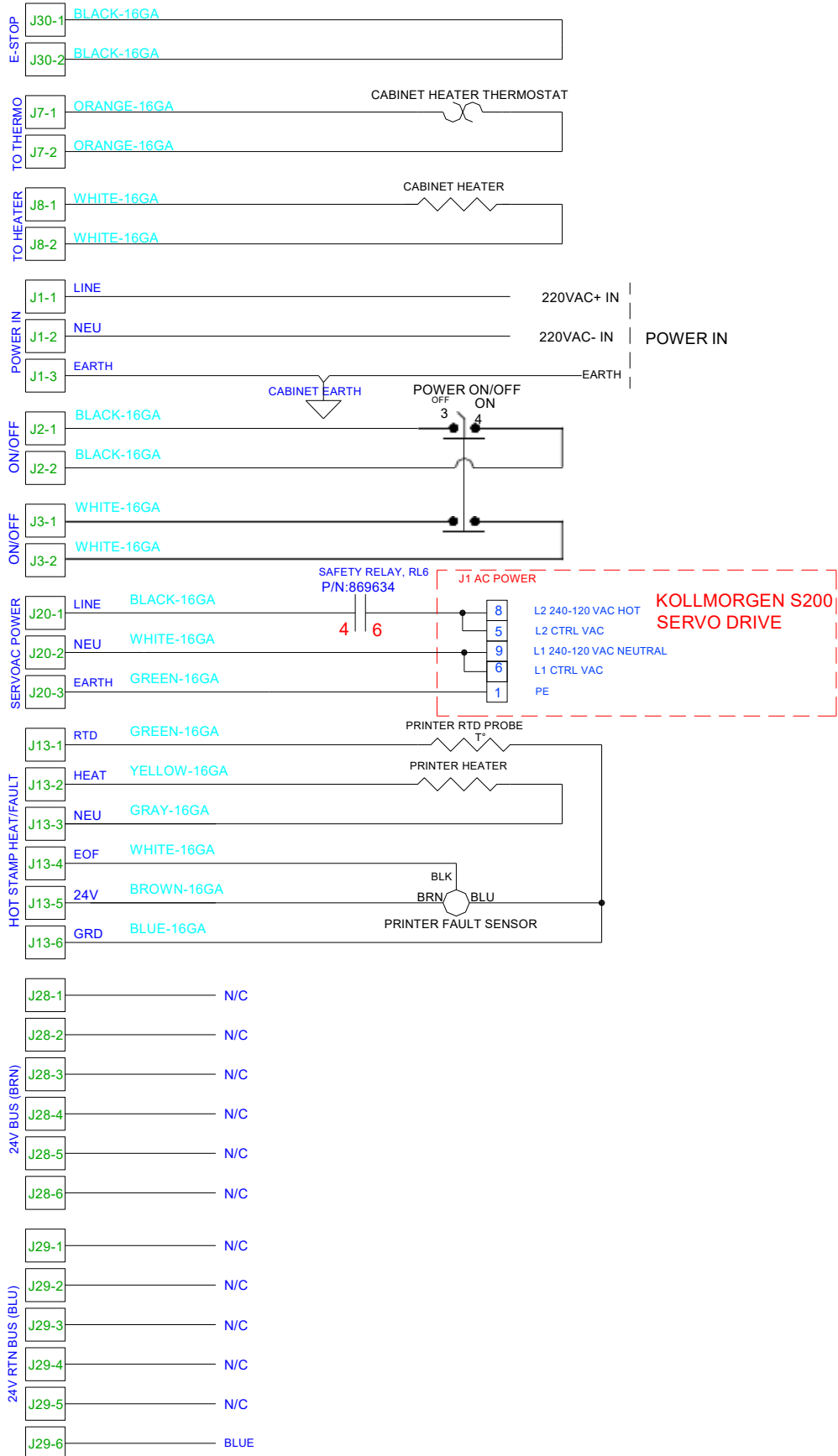

# Servo Schematics, View 2

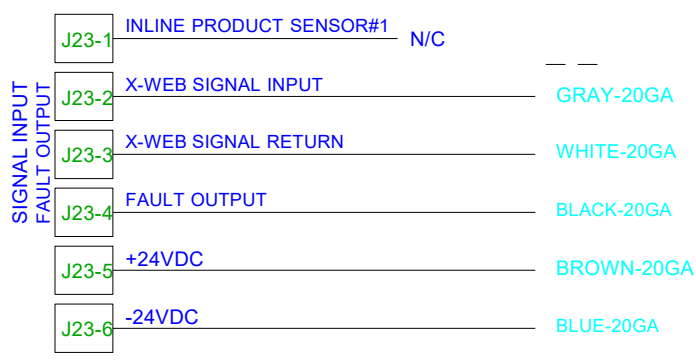
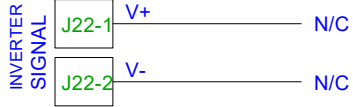
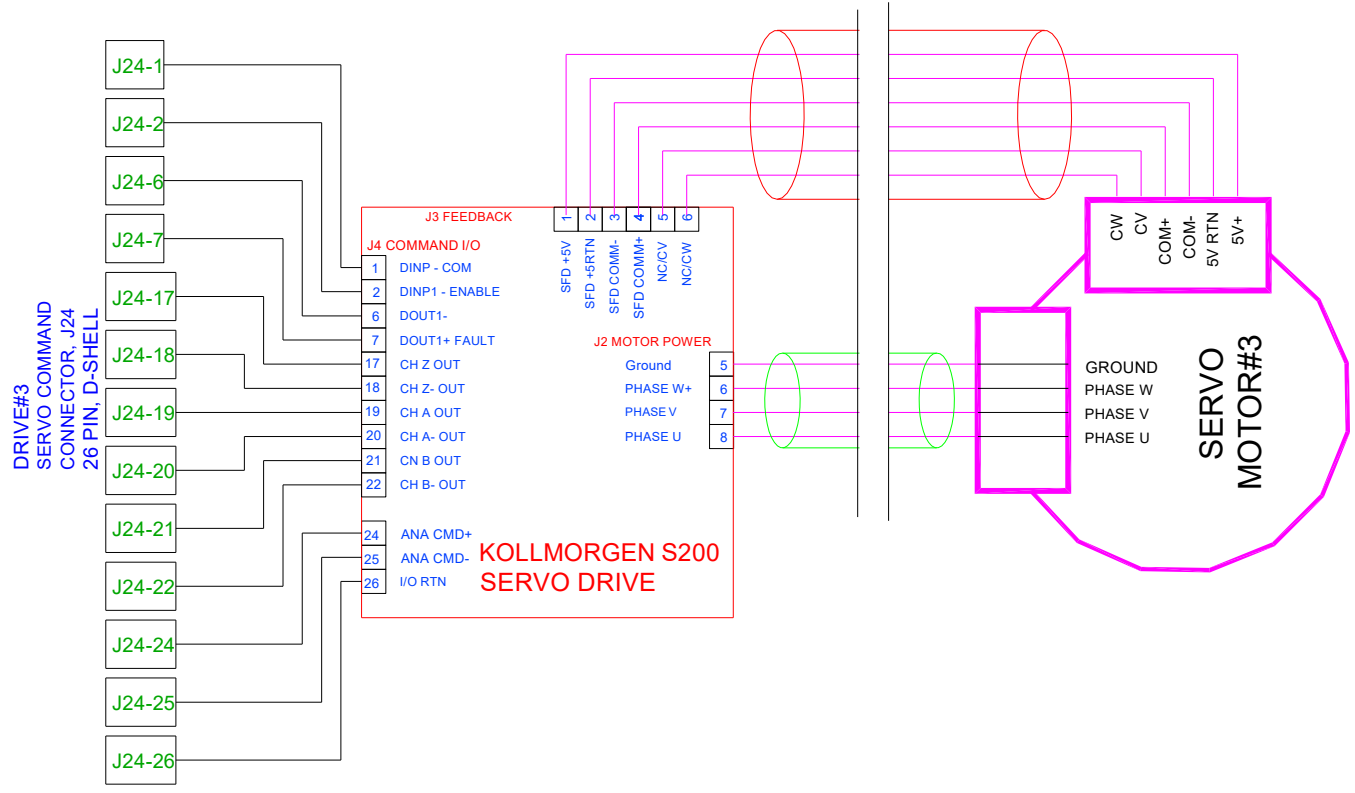

EURO, 5 PIN FEMALE BULKHEAD CONNECTOR  
MAIN SIGNAL INPUT/FAULT OUTPUT

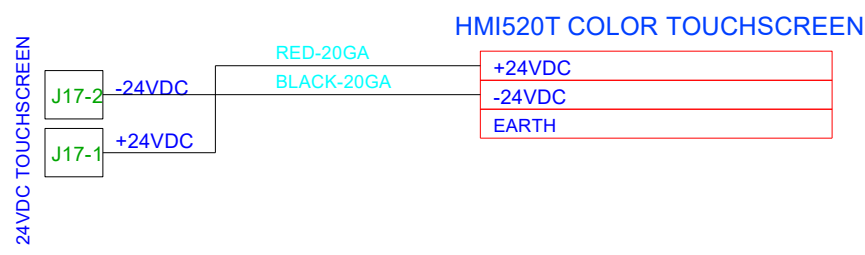

# Servo Schematics, View 3

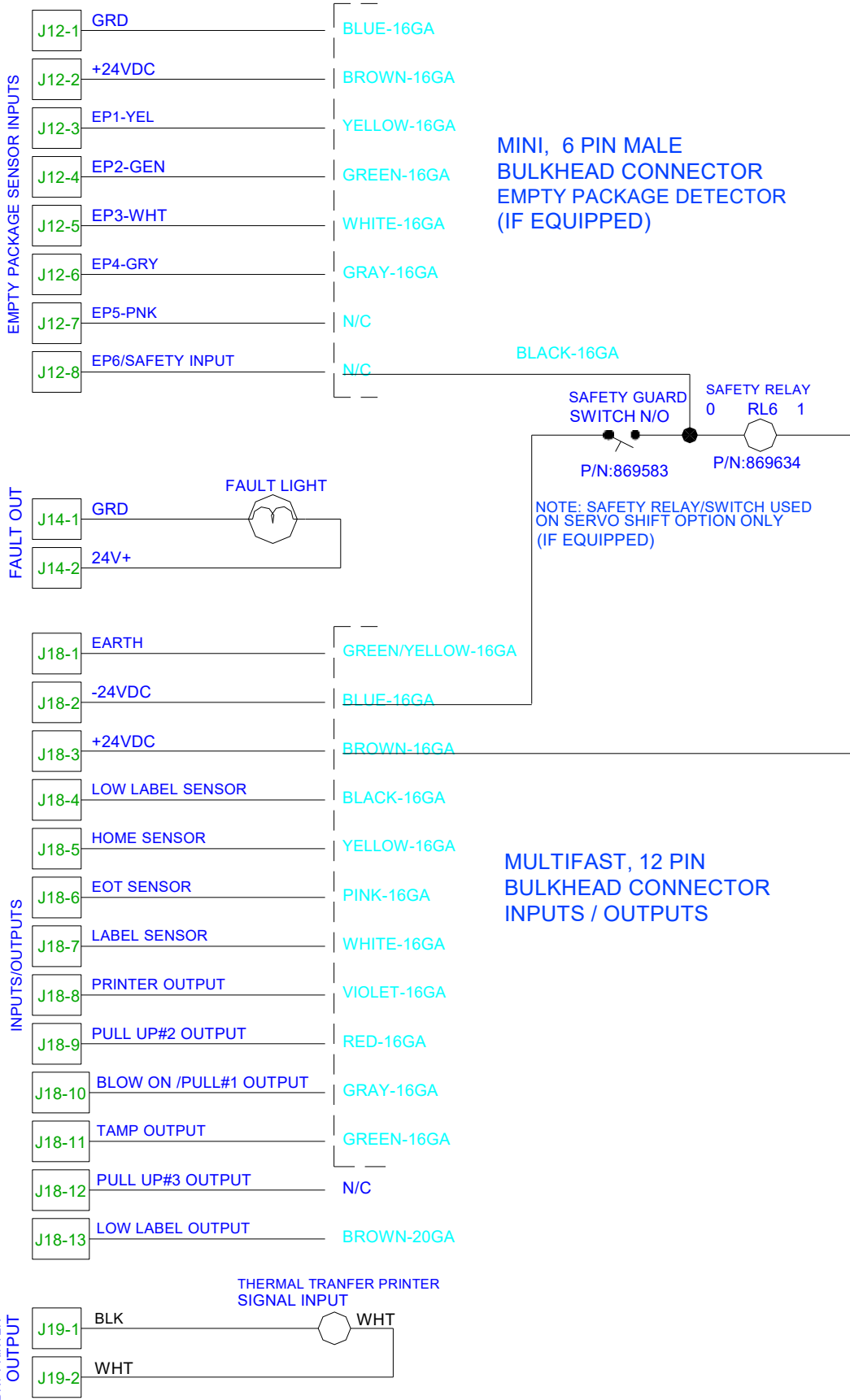

# Servo Schematics, View 4

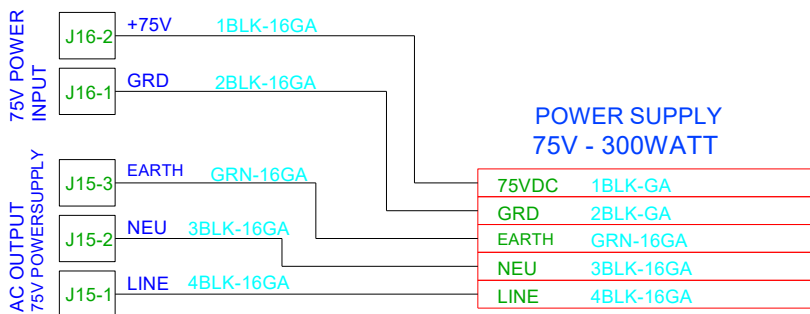
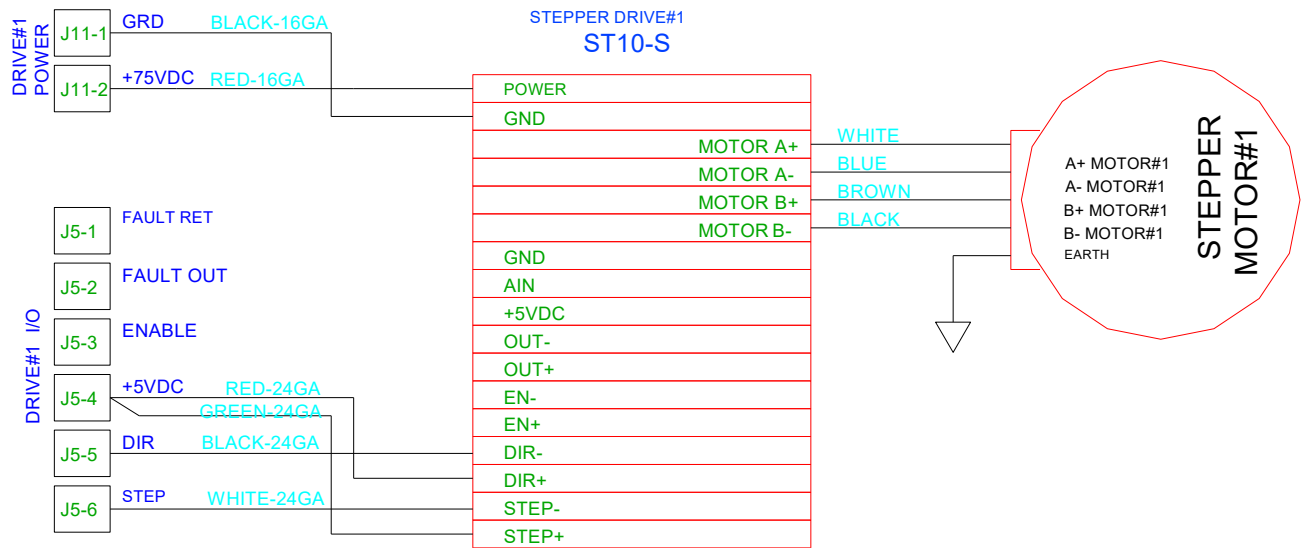
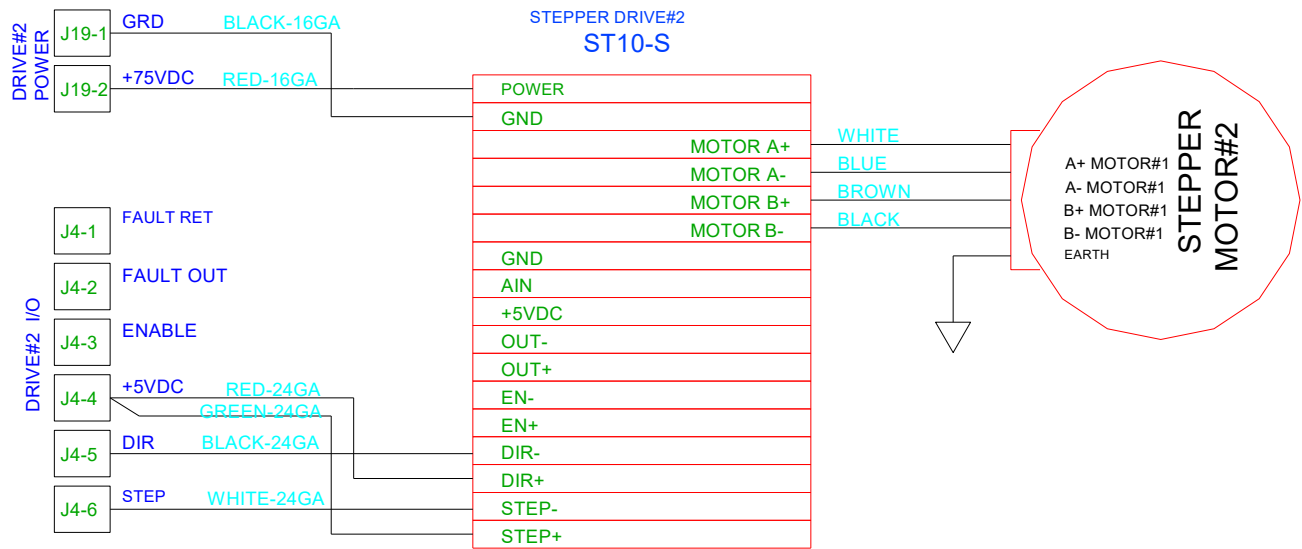

# Pneumatic Diagram

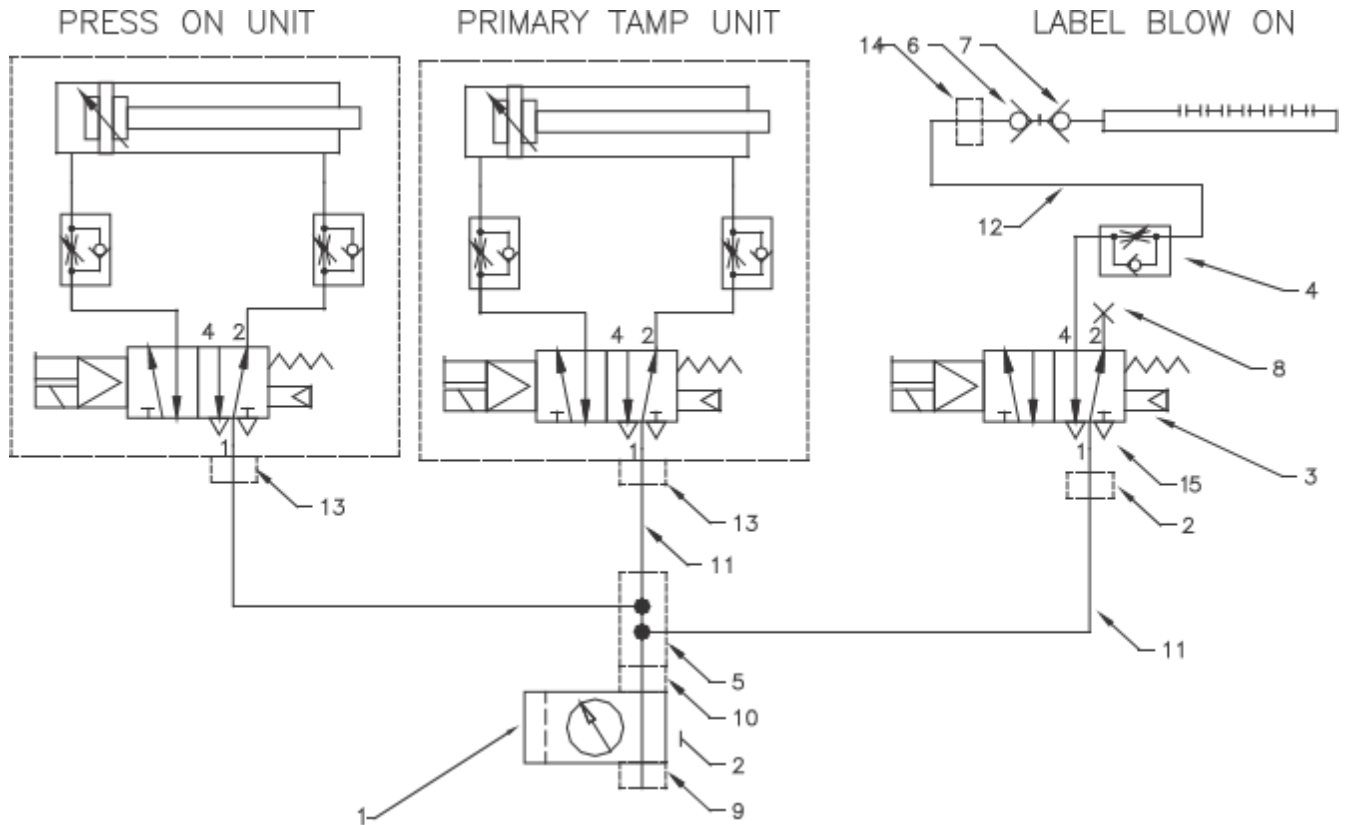

Item No.		Description
1	890534	Regulator/Dryer
2	890535	Bracket
3	866582	Valve Assembly, Single
4	866566	Fitting, Flow Control, 1/8 x 6mm
5	866252	Double Elbow Connector, 90°, 1/8 x 8mm
6	866572	Quick Coupling Socket, G1/8
7	866649	Quick Coupling Plug, G1/8
8	866246	Fitting Plug, 1/8 with gasket
9	868579	Fitting, 1/8 x 90°
10	867299	Reducing Bushing, G1/4 - G1/8
11	866576	Tubing, 8mm
12	866575	Tubing, 6mm
13	835375	Fitting, 90° PUN
14	866569	Fitting, 90°, 1/8 x 8mm
15	868568	Fitting, Straight, 1/8 x 8mm

# PA RTS

## Recommended Spare Parts

Qt y.		Description
1 ea	8 4 6 011	Linear Grease
1 ea	865007	Spring Set for Take-Up Unit
1 ea	866023	Spring Torsion, Right-Hand, for LH/DH Tension Roller
or	866024	Spring Torsion, Left-Hand, for RH/DH Tension Roller
2 ea	866048	Bearing for Dispense Roller
2 ea	866064	Bearing for Dispense Roller
2 ea	490407	Fuse, 5A
2 ea	866065	Unwind Brake Strip
1 ea	868135	Relay, 24 Volt, 12 Amp
1 ea	8 6 6121	Spring for Dancing Arm
1 ea	8 6 6127	Spring Torsion, Right-Hand
or	8 6 6128	Spring Torsion, Left-Hand
1 ea	890529	Fan, 24VDC, 26A, 172mm, 281 c.f.m.
1 ea	866519	Relay for Output
1 ea	890008	Timing Belt for Take-Up Unit
1 ea	8 6 6 5 61	Belt for DH Motor, HTD-5, 320x15
1 ea	866562	Belt for Gearbox, HTD-5, 330x15
1 ea	8 8 0 076	Timing Belt, Transporter, V2, 41T
2 ea	866801	Retaining Ring, 12mm External
2 ea	866802	Retaining Ring, 15mm External
1 ea	869514	Drive for Stepper Motors - Programmed
1 ea	866582	Single Valve Assembly
1 ea	866070	Drag Level Arm
1 ea	868694	Drag Level Arm Pad
1 ea	8 6 613 4	Bearing One-way for Take-Up Unit
1 ea	866015	Bearing for Gearbox Main Shaft
1 ea	866440	Bushing for Take-Up Clutch Assembly
1 ea	866 016	Bearing for Rubber Roller Outer
1 ea	8 6 6125	Take-Up Clutch Disc
1 ea	866438	Bushing for Take-Up Clutch Assembly
1 ea	866624	Gear for Clutch, #2, 30T
1 ea	866022	Bearing for Tension Roller
2 ea	860546	Fuse, MDA4A for Seal, 220 Volt

## Recommended Spare Parts (continued)

Qt y.	Chassis Width		Description
1 ea	ALL	8693 41	Photo Sensor, 2mm Gap
1 ea	ALL	869501	Sensor, Leuze Clear Label
1 ea	ALL	869343	Sensor, Clear, 24in, Logic
3 ea	320	890046	Tamp Blade
3 ea	420	890 047	Tamp Blade
3 ea	520	890048	Tamp Blade
3 ea	620	890049	Tamp Blade
3 ea	720	890050	Tamp Blade
3 ea	820	890 051	Tamp Blade
3 ea	320	866367	Transporter Belt
3 ea	420	866369	Transporter Belt
3 ea	520	866371	Transporter Belt
3 ea	620	866373	Transporter Belt
3 ea	720	8 67 115	Transporter Belt
3 ea	820	868642	Transporter Belt

THIS PAGE LEFT BLANK INTENTIONALLY.

# Label Tower

## Parts List

Item No.	Label Width		Description
1	ALL	890003	Tapped Insert for Drive Head
2	ALL	890 013	Unwind Mount Plate
3	ALL	860287	Screw, M8x12 Hex Head
4	ALL	8 9 0116	Tapped Insert for Drive Head
5	ALL	810107	Bolt, M8x20 Hex Head
6	ALL	8 9 017 2	Unwind Arm Plate (long) (for 14-in. disc)
	ALL	890558	Unwind Arm Plate (long) (for 18-in. disc)
	ALL	890 018	
7	ALL	890559	Unwind Arm Plate (for 14-in. disc)
	ALL	866064	Unwind Arm Plate (for 18-in. disc)
	150	890023	
8	200	8 9 0 361	Ball Bearing, 32x15x9
9	ALL	890024	Axle for Main Dispense Roller, 150mm
	ALL	866792	Axle for Main Dispense Roller, 200mm
	ALL	866802	Spacer, Main Dispense Roller Mount
10	150	895010	Washer, M8 Large OD
11	200	8 9 5 011	Retaining Ring, External 15mm
12	ALL	8 9 0 017	Idle Roller Assembly, 2-in., 150mm
13	150	895004	Idle Roller Assembly, 2 in., 200mm
	200	895005	
14	ALL	890025	Shaft Extension, Adapter
15	ALL	890424	Dancer Arm Assembly, 150mm
	ALL	866779	Dancer Arm Assembly, 200mm
	150	8 6 6113	
16	200	8 6 6115	Bearing Spacer, Dancer Arm
17	ALL	866070	Spring Mount Spindle
18	ALL	866766	Washer, 8mm Star
19	150	890102	Pivot Shaft for Brake Arm, 100mm
	200	890383	Pivot Shaft for Brake Arm, 200mm
	ALL	890104	
20	150	890105	Drag Level Arm
21	200	890383	Nut, M8-1.25 Hex
22	ALL	866824	Main Dispense Roller, 150mm
	ALL	8 6 6121	Main Dispense Roller, 200mm
	ALL	866797	
23			Unwind Shaft Spacer
24			Unwind Brake Bar
			Unwind Brake Bar
25			Screw, M8x40 Socket Set
26			Dancer Arm Spring
27			8mm Diameter Ball

# Label Tower

## Diagram

Item No.	Label Width		Description
29	ALL	890427	Unwind Stiffening Plate
30	ALL	865004	Label Reel with Hub Coupling (for 14-in. disc)
	OR	869135	Label Reel with Hub Coupling (for 18-in. disc)
	ALL	890801	
31	ALL	868694	Spacer for Unwind Neck
32	ALL	866066	Pad, Drag Lever Arm (not shown)
33	ALL	866065	Unwind Brake Drum (not shown)
34	ALL	866071	Unwind Brake Strip (not shown)
35			Spring, Drag Arm (not shown)

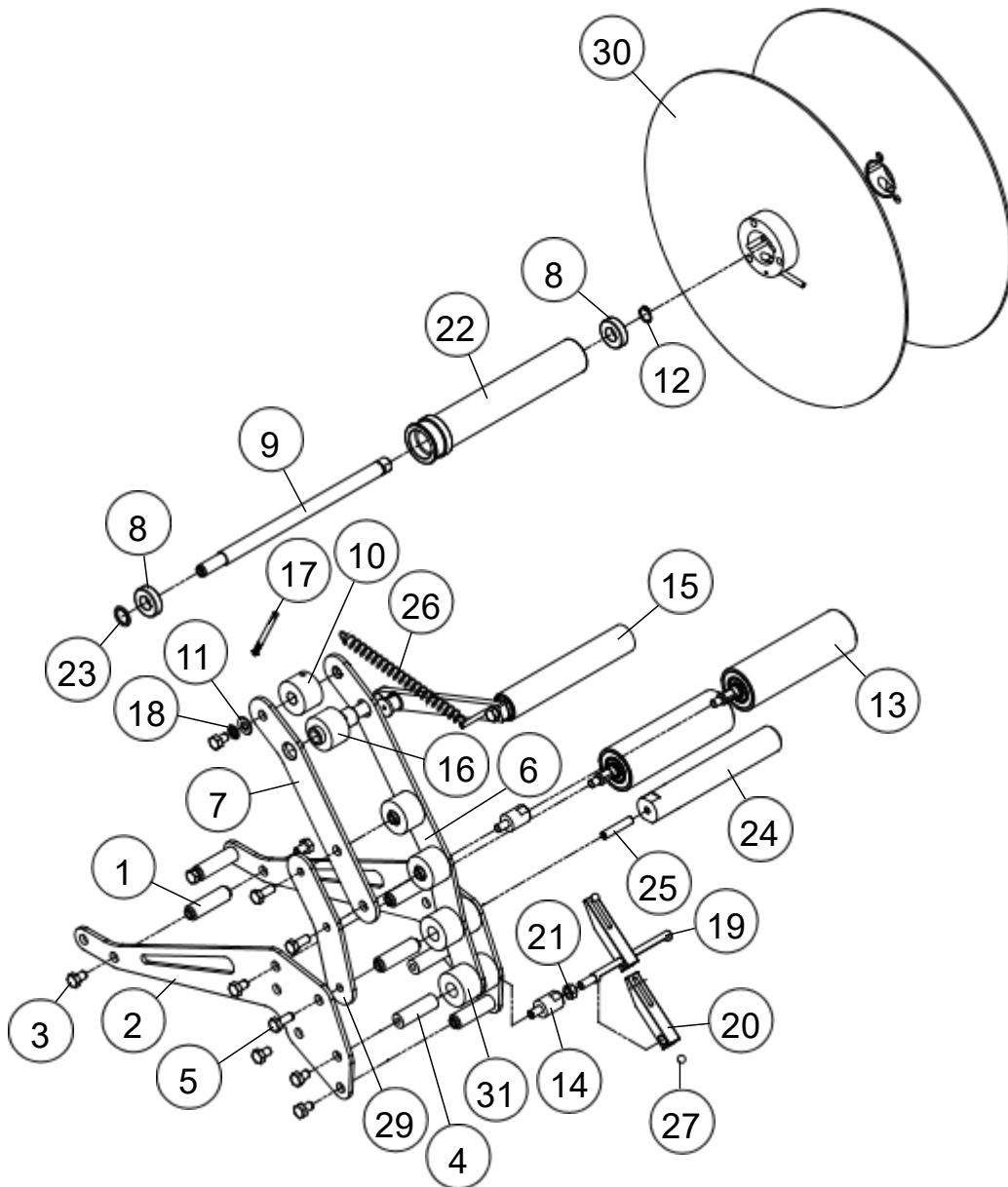

# Dancer Arm

## Parts List and Diagram

Item No.	Label Width		Description
1	ALL	890027	Dancer Arm (for 14-in. disc)
	OR	890560	Dancer Arm (for 18-in. disc)
2	ALL	866053	Brake Band Mount
3	ALL	890026	Axle for Dancer Arm
4	ALL	866471	Dancer Arm Washer
5	ALL	866779	Washer, 8mm Star
6	150	890028	Dancer Arm Roller Shaft
	200	890362	Dancer Arm Roller Shaft
	ALL	866048	
	150	890029	Bearing Ball, 28x12x8
7	200	890363	Dancer Roller
8	ALL	810108	Dancer Roller
	ALL	866801	Dancer Roller
9	ALL	810104	Bolt, M8x30 Hex Head
10	ALL	810107	Retaining Ring, External 12mm
11	ALL	866778	Screw, M5-0.8x25 Hex Head
12	ALL	866061	Bolt, M8x20 Hex Head
13	ALL	866065	Washer, 5mm Star
14			Spring Mount Spindle
15			Unwind Brake Strap (not shown)

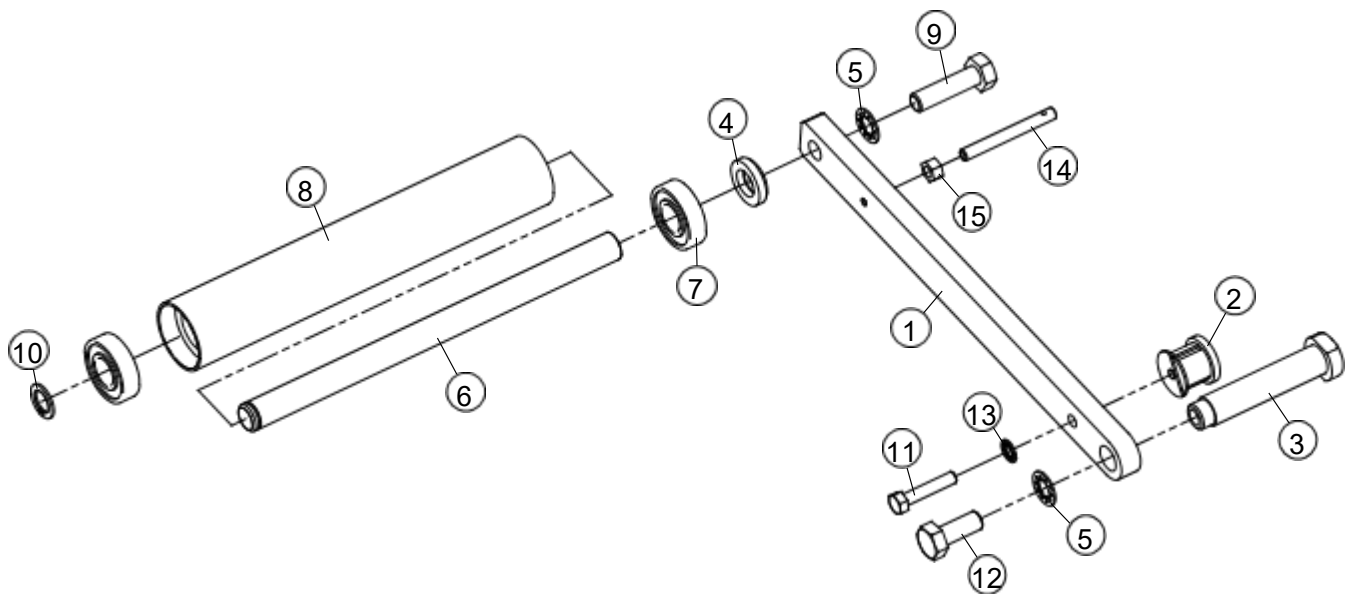

# Tension Roller

## Parts List

Item No.	Label Width		Description
1	150	865031	Tension Roller Assembly (PR/FR)
	150	865035	Tension Roller Assembly (PL/FL)
	200	865032	Tension Roller Assembly (PR/FR)
	200	865036	Tension Roller Assembly (PL/FL)
	150	866037	
2	200	866038	Primary Shaft for Tension Roller
	ALL	8 6 6274	Primary Shaft for Tension Roller
3	ALL	866023	Torsion Spring Set Collar
4	ALL	866024	Torsion Spring for Left-Hand Labeler (PL/FL)
	150	866040	Torsion Spring for Right-Hand Labeler (PR/FR)
	200	866 0 41	
5	150	866045	Tension Roller Cam
	200	866046	Tension Roller Cam
6	ALL	866047	Knurled Tension Roller
	ALL	866020	Knurled Tension Roller
	ALL	866019	
7	ALL	866022	Internal Camshaft Extension
8	ALL	866800	Garloc Bushing
9	ALL	866805	Knurled Catch Knob
10	ALL	86670 0	Bearing
11			Retaining Ring, External 10mm
12			Retaining Ring, External 17mm
13			Dowel, 3mm x 2mm

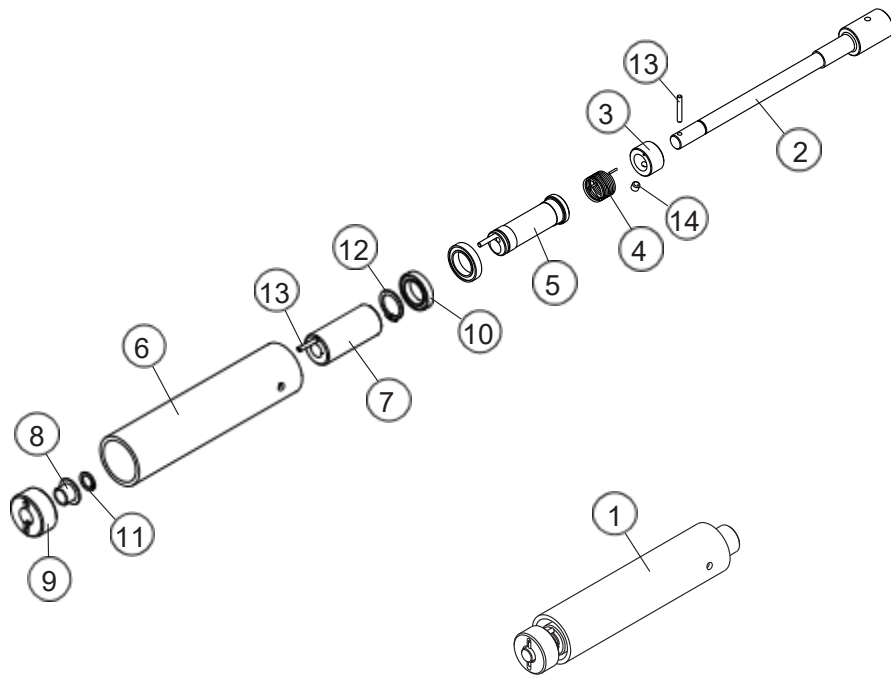

# Take-Up Unit

## Parts List

Item No.	Label Width		Description
1	ALL	8 6 6131	Take-Up Roller Shaft
2	ALL	8 6 6128	Torsion Spring, Left-Hand
3	ALL	8 6 6124	Take-Up Spring Housing
4	ALL	8 6 6132	Take-Up Pulley Insert
5	ALL	866624	Gear for Clutch, No. 2, 30T
6	ALL	866438	Bushing Clutch Assembly
7	ALL	866444	Take-Up Spring Housing
8	ALL	866439	Bushing, Plastic 10x12x9
9	ALL	866445	Clutch Disc - TFE
10	ALL	8 6 6125	Take-Up Clutch Disc
11	ALL	8 6 6123	Pressure Plate Disc
12	ALL	866440	Bushing for Clutch Assembly
13	ALL	866 016	Bearing
14	ALL	865007	Spring, Compression
15	ALL	8 6 6120	Set Collar
16	ALL	866817	Setscrew, M5-0.8x5
17	ALL	866796	4mm Ball for Clutch
18	ALL	8 6 613 0	Bearing Flange
19	ALL	8 6 613 4	One-Way Bearing
20	ALL	8 6 6135	Bearing, Inner Race
21	150	865015	Take-Up Hub Assembly, 150mm
	200	865 016	Take-Up Hub Assembly, 200mm
	ALL	866769	
	ALL	866779	
	150	8 6 5 011	
	200	865012	
	150	865 0 41	
22	200	865042	Nut, 8mm Dome Hex
23			Washer, 8mm Split
24			Take-Up Unit Complete, Right-Hand
			Take-Up Unit Complete, Right-Hand
			Take-Up Unit Complete, Left Hand
			Take-Up Unit Complete, Left-Hand

# Take-Up Unit Diagram

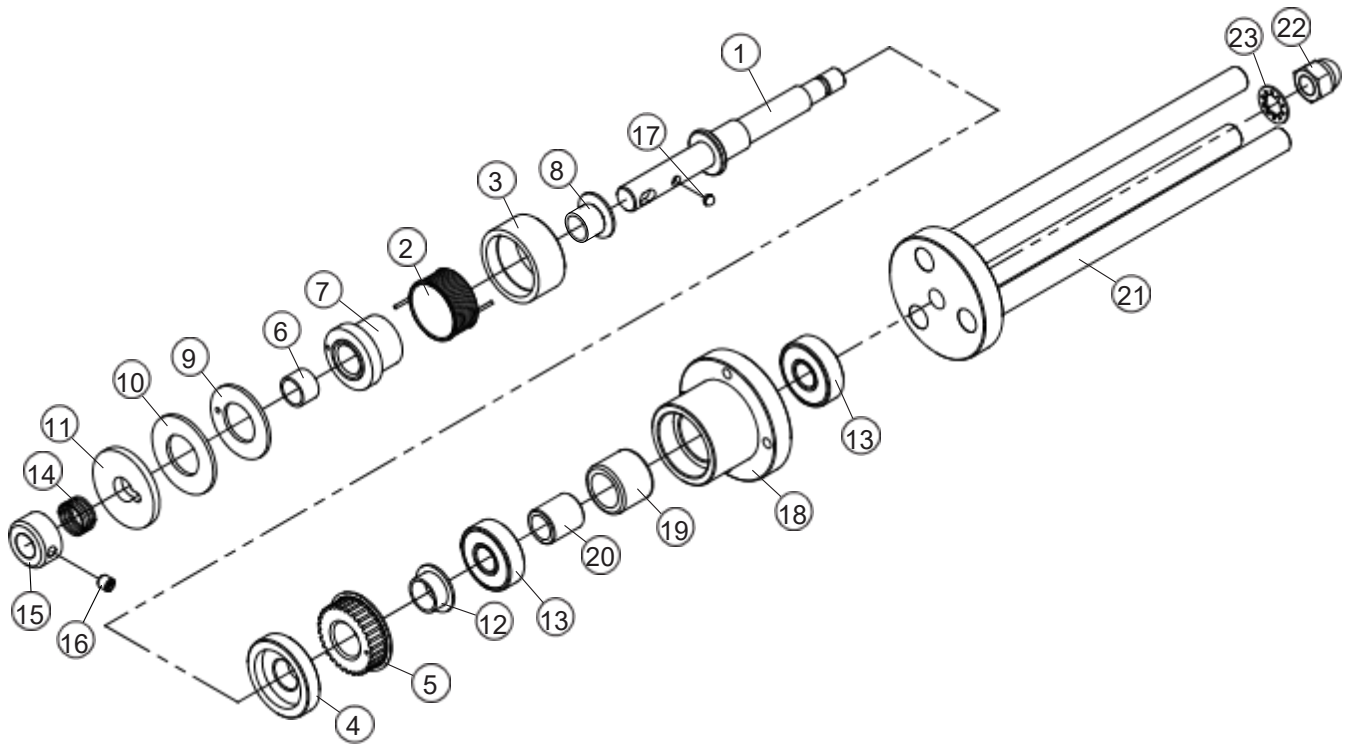

# Drive Roller

## Parts List and Diagram

Item No.	Label Width		Description
1	150	865025	Rubber Roller Assembly
	200	865026	Rubber Roller Assembly
2	ALL	866035	End Cap
3	150	865021	Rubber Roller
	200	865022	Rubber Roller
	ALL	866015	Bearing
4	ALL	866030	Bearing Flange for Rubber Roller
5	ALL	866 016	Bearing Flange for Rubber Roller
6			Bearing

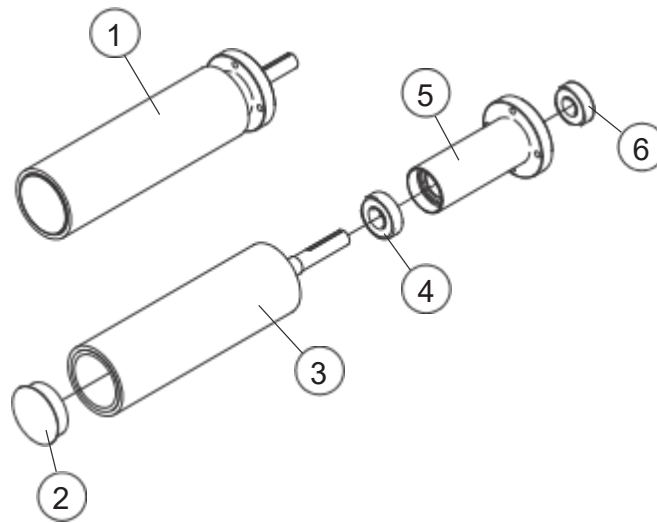

# Roller, 2-in. Nominal

## Parts List and Diagram

Item No.	Label Width		Description
1	150	890 021	Axle, Drive Head Roller
	200	890360	Axle, Drive Head Roller
2	ALL	866801	Retaining Ring, External, 12mm
3	ALL	866048	Bearing Ball, 28x12x8
4	ALL	890020	Hub for 2-in. Idler Roller
5	150	890 019	Idler Roller, 2-in., 150mm
	200	890359	Idler Roller, 2-in., 200mm
	ALL	890729	
6			O-Ring Spacer for Idler Roller

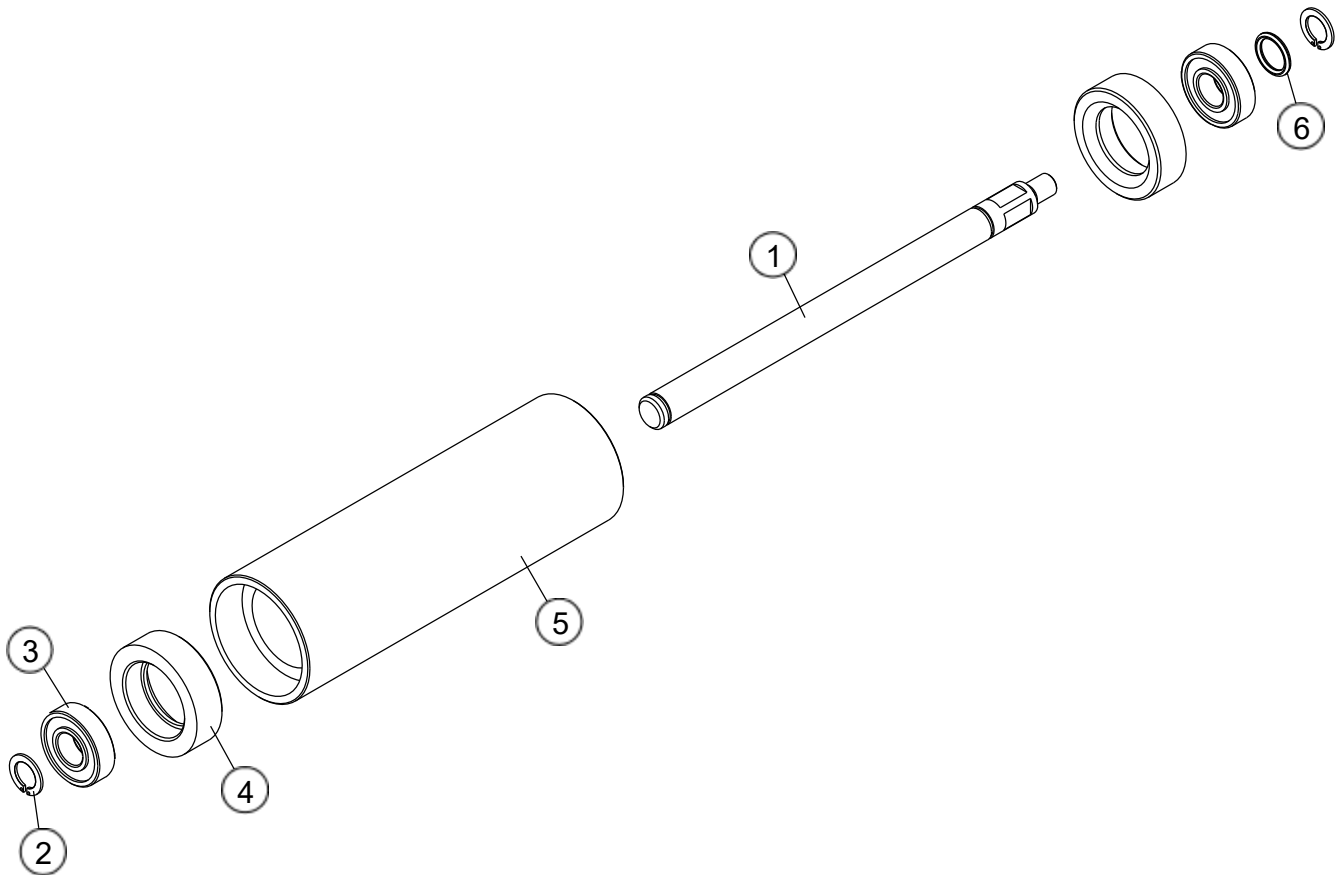

# Label Head Assembly

## Parts List

Item No.	Label Width		Description
1	ALL	890003	Tapped Insert for Drive Head
2	ALL	890007	Drive Head Front Plate
3	ALL	810107	Bolt, M8x20 Hex Head
4	150	865031	Tension Roller Assembly, Right-Hand
	200	865032	Tension Roller Assembly, Right-Hand
	150	865035	Tension Roller Assembly, Left-Hand
	200	865036	Tension Roller Assembly, Left-Hand
	ALL	866621	
5	ALL	865025	Timing Pulley for Drive Head, 32T
6	ALL	866628	Rubber Drive Roller Assembly, CPL 200
7	ALL	866801	Gearbox Head Washer
8	150	866469	Retaining Ring, 12mm External
9	200	866470	Idler Roller Shaft, DH
	ALL	866401	Idler Roller Shaft, DH
	ALL	866625	
	ALL	866810	Backing Paper Roller
10	ALL	81010 0	Timing Pulley for Clutch Assembly, 44T
11	150	8 6 5 0 1 1	Key, 3x3x25
12	200	865012	Bolt, M4x20 Hex Head
13	150	865 0 4 1	Take-Up Unit Assembly, Right-Hand
14	200	865042	Take-Up Unit Assembly, Right-Hand
	ALL	810178	Take-Up Unit Assembly, Left-Hand
	ALL	8 6 6 5 6 1	Take-Up Unit Assembly, Left-Hand
	ALL	890008	Take-Up Unit Assembly, Left-Hand
	ALL	890009	
15	ALL	868599	Bolt, M5x16 Hex Head
16	ALL	8 9 0 0 1 1	Timing Belt for Drive Motor
17	ALL	867392	Timing Belt for Take-Up Unit
18	ALL	890 0 1 2	Screw, M5x16 Slotted Cheesehead
19	ALL	860904	Screw, M8x20 Slotted Flat Head
20	ALL	E146	Drive Head Back Plate
-	150	890 0 2 1	Drive Head Back Plate, Jumbo Unwind
21	200	890533	Take-Up Guard
22	ALL	890729	Plug, 7.5mm
23	ALL	866772	Plug, 12mm
24			Axle, Drive Head Roller
			Axle, Drive Head Roller
25			O-Ring for Idler Roller
26			Washer, 4mm Flat

# Label Head Assembly

## Diagram

Item No.	Label Width		Description
27	ALL	866783	Washer, 4mm Split
28	ALL	890443	Steel Insert for Drive Plate
29	ALL	890444	Spacer for Drive Head Plate
30	ALL	860260	Washer, 5mm Split

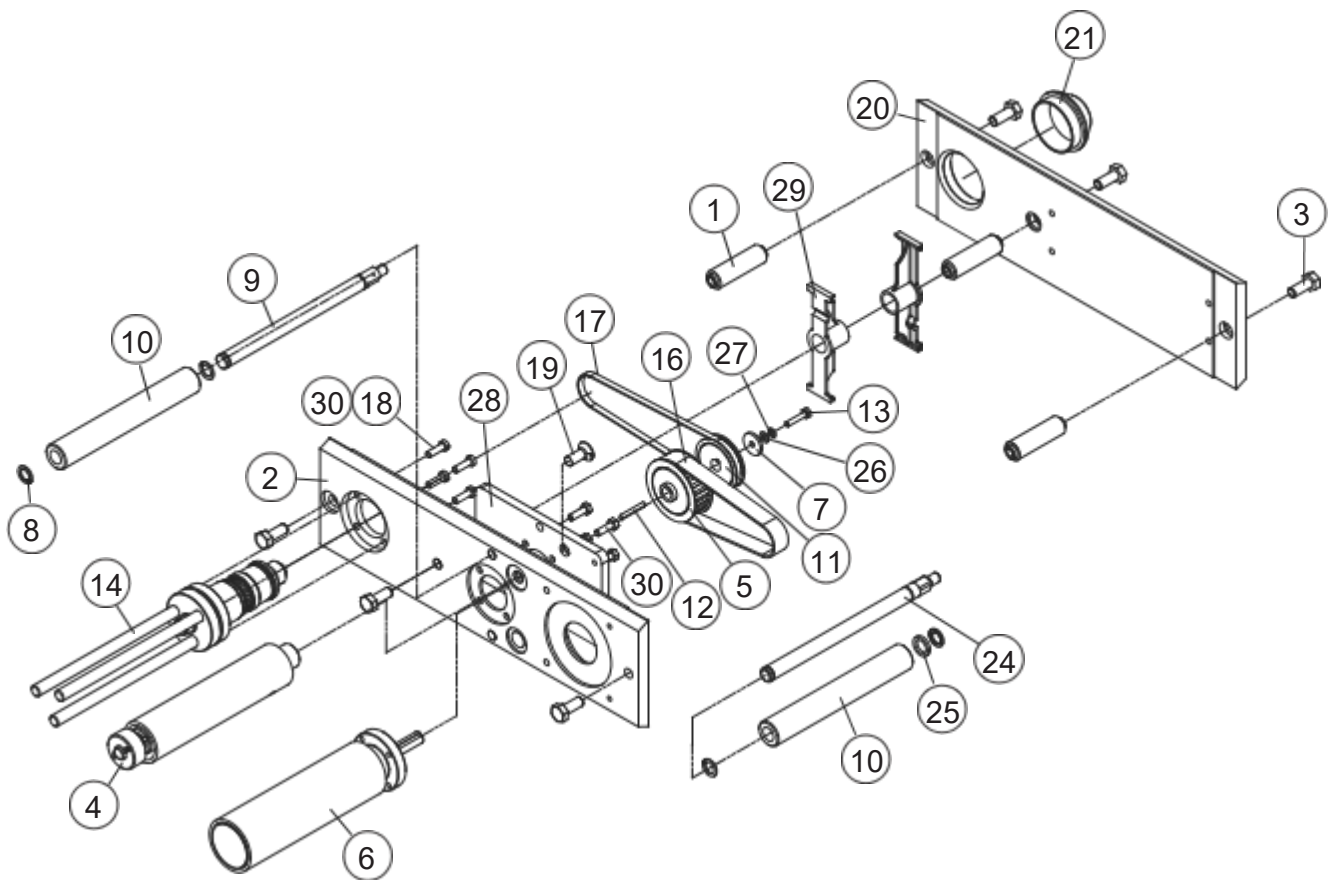

# Tamp Unit, 320mm

## Parts List

Item No.	Label Width		Description
1	150	895301	Transfer Belt Assembly, Right-Hand
	150	895313	Transfer Belt Assembly, Left-Hand
	200	895325	Transfer Belt Assembly, Right-Hand
	200	895337	Transfer Belt Assembly, Left-Hand
	150	895300	
2	150	895312	Push Blade Assembly, Right-Hand
	200	895324	Push Blade Assembly, Left-Hand
	200	895336	Push Blade Assembly, Right-Hand
	ALL	750676	Push Blade Assembly, Left-Hand
	ALL	810105	
3	ALL	83518-0	Screw, M10x70 Hex Head
4	ALL	890078	Bolt, M6x25 Hex Head
5	ALL	866774	Nut, 8mm Jam Nut
6	ALL	890071	Mounting Sleeve
7	ALL	890095	Washer, 6mm Flat
8	150	895012	Tamp Plate Lock
9	200	895013	Large Washer for Mounting Blocks
10	ALL	890223	Idler Roller Assembly, 1.25-in.
	ALL	890146	Idler Roller Assembly, 1.25-in.
			Bulkhead Connector
11			
12			Tamp Unit Chassis Mount Block

**NOTE:** Parts have been removed from the push blade assembly (Item No. 2) for clarity.

# Tamp Unit, 320mm Diagram

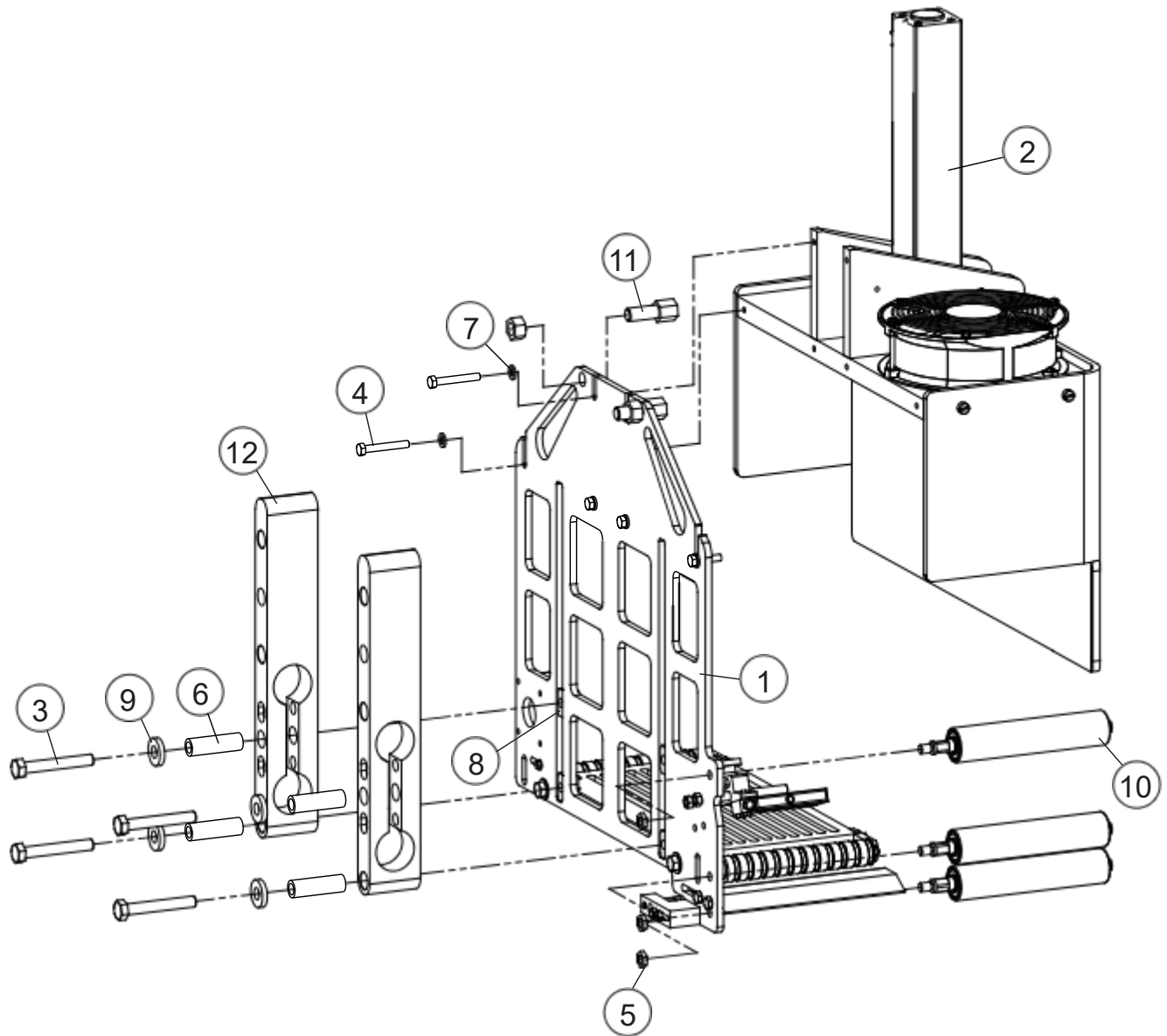

# Tamp Unit, 420-520mm

## Parts List

Item No.	Label Width	Chassis Width		Description
1	150	420	895303	Transfer Belt Assembly, Right-Hand
	150	420	895315	Transfer Belt Assembly, Left-Hand
	150	520	895305	Transfer Belt Assembly, Right-Hand
	150	520	8 95 317	Transfer Belt Assembly, Left-Hand
	200	420	895327	Transfer Belt Assembly, Right Hand
	200	420	895339	Transfer Belt Assembly, Left-Hand
	200	520	895329	Transfer Belt Assembly, Right-Hand
	200	520	8953 41	Transfer Belt Assembly, Left-Hand
	150	420	895302	
2	150	420	895314	
	150	520	895304	Push Blade Assembly, Right-Hand
	150	520	895316	Push Blade Assembly, Left-Hand
	200	420	895326	Push Blade Assembly, Right-Hand
	200	420	895338	Push Blade Assembly, Left-Hand
	200	520	895328	Push Blade Assembly, Right Hand
	200	520	895340	Push Blade Assembly, Left-Hand
	ALL	ALL	750676	Push Blade Assembly, Right-Hand
	ALL	ALL	810105	Push Blade Assembly, Left-Hand
	ALL	ALL	83518 0	
3	ALL	ALL	890078	Screw, M10x70 Hex Head
4	ALL	ALL	866774	Bolt, M6x25 Hex Head
5	ALL	ALL	890071	Nut, 8mm Jam
6	ALL	ALL	890095	Mounting Sleeve
7	150	ALL	895012	Washer, 6mm Flat
8	200	ALL	895013	Tamp Plate Lock
9	ALL	ALL	890223	Large Washer for Mounting Blocks
10	ALL	ALL	890146	Idler Roller Assembly, 1.25-in.
	ALL	420	890726	Idler Roller Assembly, 1.25-in.
	ALL	520	890428	Bulkhead Connector
11				
12				Tamp Unit Chassis Mount Block
13				Tamp Unit Crossbar
				Tamp Unit Crossbar

# Tamp Unit, 420-520mm Diagram

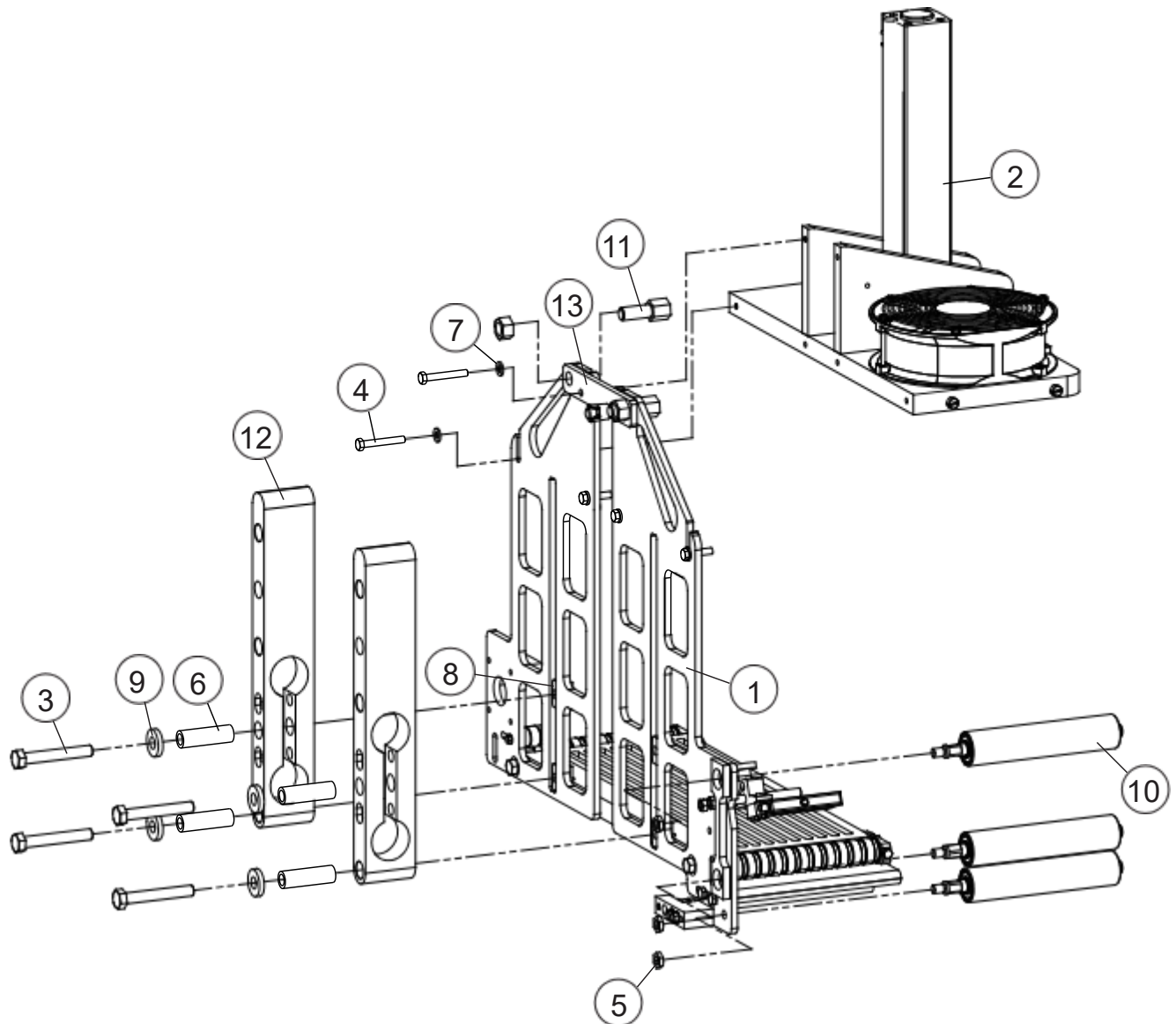

# Tamp Unit, 620-820mm

## Parts List

Item No.	Label Width	Chassis Width		Description
1	150	620	895307	Transfer Belt Assembly, Right-Hand
	150	620	895319	Transfer Belt Assembly, Left-Hand
	150	720	895309	Transfer Belt Assembly, Right-Hand
	150	720	895321	Transfer Belt Assembly, Left-Hand
	150	820	8 9 5 3 1 1	Transfer Belt Assembly, Right-Hand
	150	820	895323	Transfer Belt Assembly, Left-Hand
	200	620	895331	Transfer Belt Assembly, Right-Hand
	200	620	895343	Transfer Belt Assembly, Left-Hand
	200	720	895333	Transfer Belt Assembly, Right-Hand
	200	720	895345	Transfer Belt Assembly, Left-Hand
	200	820	895335	Transfer Belt Assembly, Right-Hand
	200	820	895347	Transfer Belt Assembly, Left-Hand
	150	620	895306	
	150	620	895318	
2	150	720	895308	Push Blade Assembly, Right-Hand
	150	720	895320	Push Blade Assembly, Left-Hand
	150	820	895310	Push Blade Assembly, Right-Hand
	150	820	895322	Push Blade Assembly, Left-Hand
	200	620	895330	Push Blade Assembly, Right-Hand
	200	620	895342	Push Blade Assembly, Left-Hand
	200	720	895332	Push Blade Assembly, Right-Hand
	200	720	895344	Push Blade Assembly, Left-Hand
	200	820	895334	Push Blade Assembly, Right-Hand
	200	820	895346	Push Blade Assembly, Left-Hand
	ALL	ALL	750676	Push Blade Assembly, Right-Hand
	ALL	ALL	810105	Push Blade Assembly, Left-Hand
	ALL	ALL	83518 0	
	ALL	ALL	890078	
	ALL	ALL	866774	
3	ALL	ALL	890071	Bolt, M10x70 Hex Head
4	ALL	ALL	890095	Bolt, M6x25 Hex Head
5	150	ALL	895012	Nut, 8mm Jam
6	200	ALL	890 013	Mounting Sleeve
7				Washer, 6mm Flat
8				Tamp Plate Lock
9				Large Washer for Mounting Blocks
10				Idler Roller Assembly, 1.25-in.
				Idler Roller Assembly, 1.25-in.

# Tamp Unit, 620-820mm

## Diagram

Item No.	Label Width	Chassis Width		Description
11	ALL	ALL	890223	Bulkhead Connector
12	ALL	ALL	890146	Tamp Unit Chassis Mount Block
13	ALL	620	890429	Tamp Unit Crossbar
	ALL	720	890430	Tamp Unit Crossbar
	ALL	820	890431	Tamp Unit Crossbar

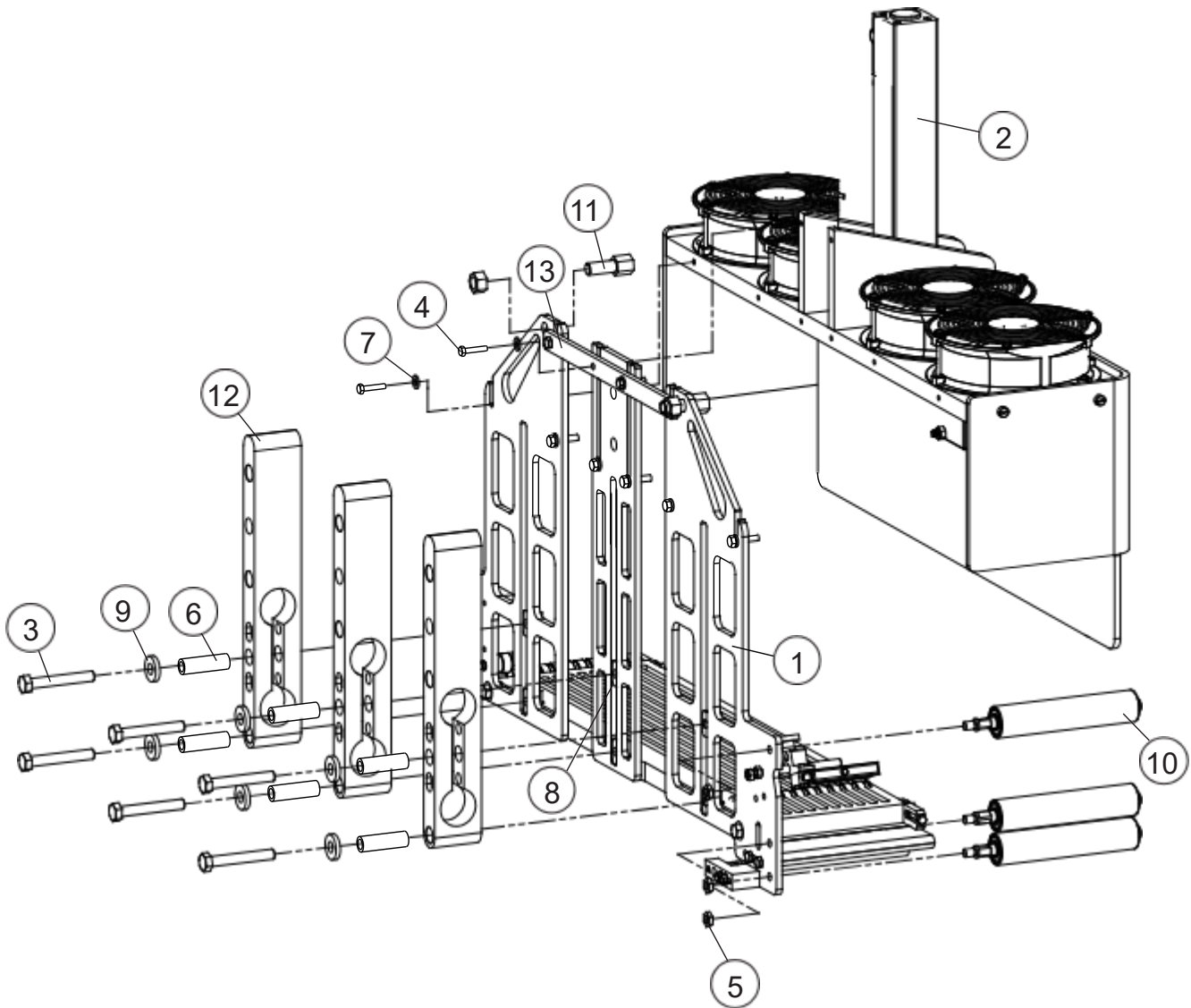

# Transfer Belt Assembly, 320mm

## Parts List

Item No.	Label Width		Description
1	150	890040	Transporter
	200	890370	Transporter
2	150	890072	Transporter Mount Shaft
	200	890379	Transporter Mount Shaft
	150	890062	Transporter Mount Shaft
3	200	890 376	Multi-Belt Roller
	ALL	890551	Multi-Belt Roller
4	150	890073	Flange Bearing
5	200	890380	Multi-Belt Roller Shaft
	ALL	890058	Multi-Belt Roller Shaft
	ALL	890060	Multi-Belt Roller Shaft
6	ALL	8 9 0 0 61	Multi-Belt Roller Bracket, Right Front
7	ALL	890059	Multi-Belt Roller Bracket, Left Front
8	ALL	810108	Multi-Belt Roller Bracket, Left Rear
9	ALL	866792	Multi-Belt Roller Bracket, Right Rear
10	ALL	8 6 9 5 61	Bolt, M8x30 Hex Head
11	ALL	8 6 0 2 61	Washer, M8 Large OD (not shown)
12	ALL	866367	Screw, M5-0.8x25 Hex Head
13	ALL	890063	Nut, M5 Lock
14	ALL	890 076	Transporter Belt, 320mm
15	150	890446	Transporter Multi-Belt Roller Timing Gear
16	200	890548	Transporter Timing Belt
17	150	8 6 6 4 11	Belt Guard
	200	868716	Belt Guard
	ALL	866 412	Blow-On Tube
	ALL	866572	Blow-On Tube
18	ALL	866649	
	ALL	890070	
	ALL	890508	
19	ALL	866701	Blow-On Angle Adjuster
20	ALL	866772	Quick Coupling Socket, G1/8
21	150	890069	Quick Coupling Plug, G1/8
22	200	890378	Blow-On Tube Mount
23	ALL	8670 03	Bolt, M4x40 Hex Head
24	ALL	81010 0	Dowel Pin, 5mm x 50mm
25			Washer, 4mm Flat
26			Peel Bar
			Peel Bar
27			Bolt, M6x30 Hex Head
28			Bolt, M4x20 Hex Head

# Transfer Belt Assembly, 320mm

## Diagram

Item No.	Label Width		Description
29	ALL	866765	Nut, M6-1.0 Hex
30	ALL	890584	Photo Sensor, 2mm Gap
	ALL	895350	Photo Sensor, Clear Label
31	150	890 067	Photoeye Mount Shaft
	200	890399	
	ALL	890879	Photoeye Mount Shaft
32	ALL	890258	Mount Block, Photo Sensor, 2mm Gap
33	ALL	866 410	Thumb Screw
34	ALL	866772	Fan Box Idler Roller
35	ALL	866801	Washer, 4mm Flat
36	ALL	890075	Retaining Ring, External 12mm
37	ALL	890077	Motor Mount, Transporter
38	ALL	890167	Belt Tensioner for Transporter
39	ALL	810102	Tamp Back Plate
40	ALL	890593	Screw, M5x12 Hex Head
41	ALL	866834	Roll Pin, 1.5 x 8
42	ALL	866774	Set Screw, M10x10
43	ALL	866447	Washer, M6 Flat
44	ALL	866783	Fan Mount Washer - ONLY ON FRONT
45			Washer, 4mm Split

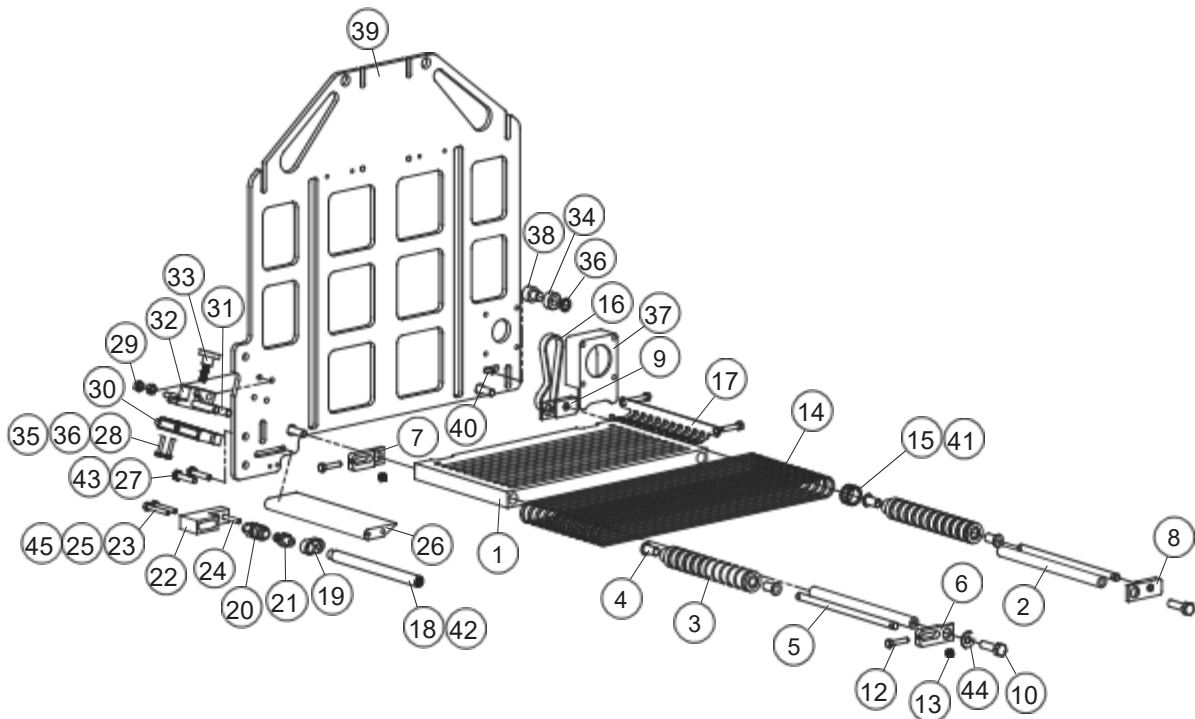

# Transfer Belt Assembly, 420mm

## Parts List

Item No.	Label Width		Description
1	150	890 0 41	Transporter
	200	890371	Transporter
2	150	890072	Transporter Mount Shaft
	200	890379	Transporter Mount Shaft
	150	890062	Transporter Mount Shaft
3	200	890 376	Multi-Belt Roller
	ALL	890551	Multi-Belt Roller
4	150	890073	Flange Bearing
5	200	890380	Multi-Belt Roller Shaft
	ALL	890058	Multi-Belt Roller Shaft
	ALL	890060	Multi-Belt Roller Shaft
6	ALL	8 9 0 0 61	Multi-Belt Roller Bracket, Right Front
7	ALL	890059	Multi-Belt Roller Bracket, Left Front
8	ALL	810108	Multi-Belt Roller Bracket, Left Rear
9	ALL	866792	Multi-Belt Roller Bracket, Right Rear
10	ALL	8 695 61	Bolt, M8x30 Hex Head
11	ALL	8 6 0 261	Washer, M8 Large OD
12	ALL	866369	Screw, M5-0.8x25 Hex Head
13	ALL	890063	Nut, M5 Lock
14	ALL	890 076	Transporter Belt, 420mm
15	150	890446	Transporter Multi-Belt Roller Timing Gear
16	200	890548	Transporter Timing Belt
17	150	8 6 6 411	Belt Guard
	200	868716	Belt Guard
	ALL	866 412	Blow-On Tube
	ALL	866572	Blow-On Tube
18	ALL	866649	
	ALL	890070	
	ALL	890508	
19	ALL	866701	Blow-On Angle Adjuster
20	ALL	866772	Quick Coupling Socket, G1/8
21			Quick Coupling Plug, G1/8
22			Blow-On Tube Mount
23			Bolt, M4x40 Hex Head
24			Dowel Pin, 5mm x 50mm
25			Washer, 4mm Flat

# Transfer Belt Assembly, 420mm Diagram

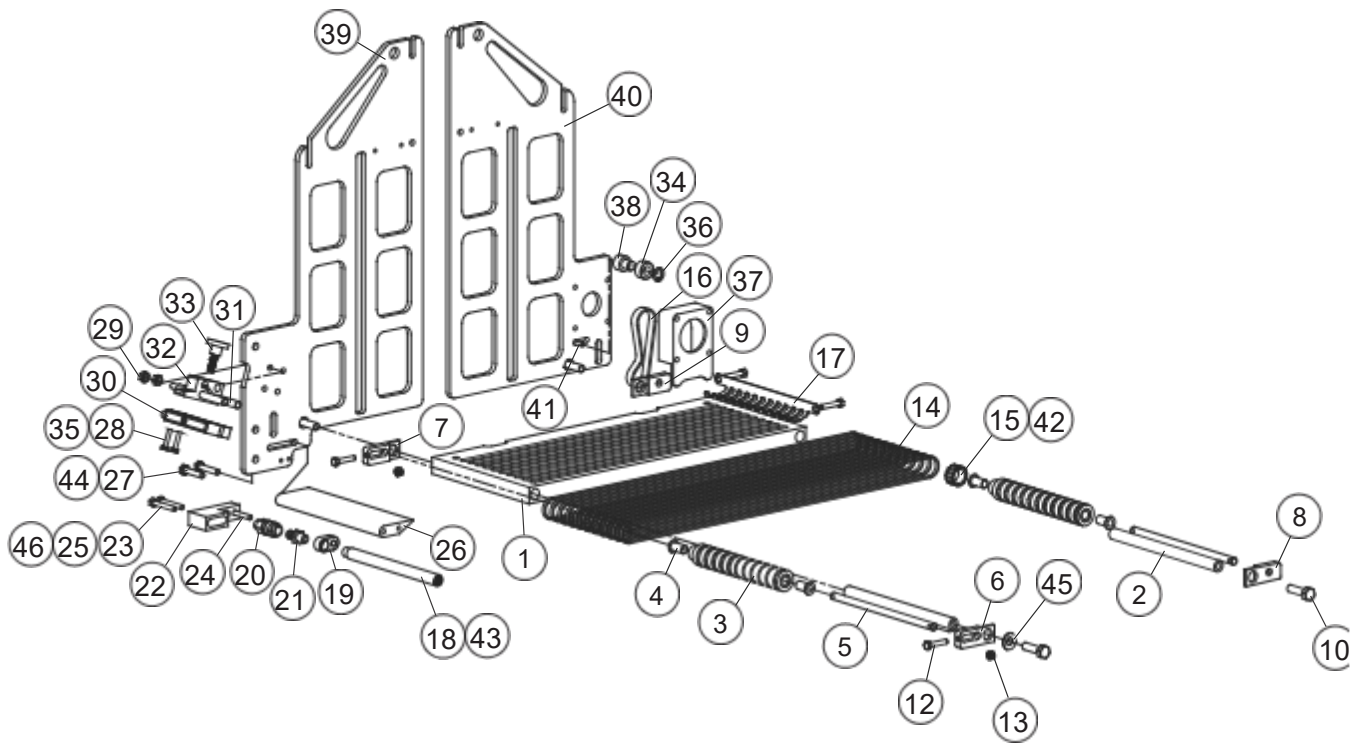

# Transfer Belt Assembly, 420mm (continued)

## Parts List

Item No.	Label Width		Description
26	150	890069	Peel Bar
	200	890378	Peel Bar
27	ALL	8670 03	Bolt, M6x30 Hex Head
28	ALL	81010 0	Bolt, M4x20 Hex Head
29	ALL	866765	Nut, M6-1.0 Hex
30	ALL	890584	Photo Sensor, 2mm Gap
	150	890 067	Photo Sensor, Clear Label
31	200	890399	Photoeye Mount Shaft
	ALL	890068	Photoeye Mount Shaft
	ALL	890258	
32	ALL	866 410	Mount Block, Photo Sensor, 2mm Gap
33	ALL	866772	Thumb Screw
34	ALL	866801	Fan Box Idler Roller
35	ALL	890075	Washer, 4mm Flat
36	ALL	890077	Retaining Ring, External 12mm
37	ALL	890065	Motor Mount, Transporter
38	ALL	890064	Belt Tensioner for Transporter
39	ALL	810102	Tamp Back Plate, Right-Hand
40	ALL	890593	Tamp Back Plate, Left-Hand
41			Screw, M5x12 Hex Head
42			Roll Pin, 1.5 x 8
43	ALL	866834	Set Screw, M10x10
44	ALL	866774	Washer, M6 Flat
45	ALL	866447	Fan Mount Washer - ONLY ON FRONT
46	ALL	866783	Washer, 4mm Split

# Transfer Belt Assembly, 420mm (continued)

## Diagram

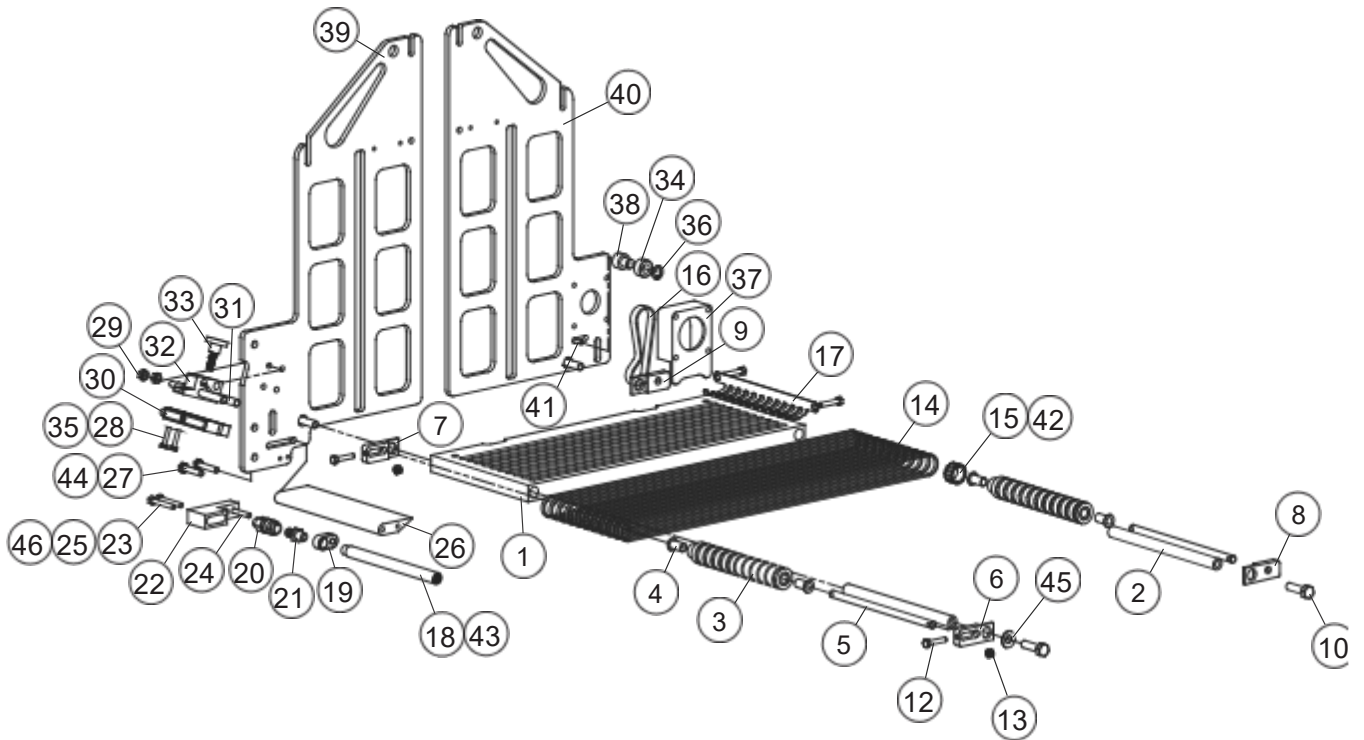

# Transfer Belt Assembly, 520-820mm

## Parts List

Item No.	Label Width	Chassis Width		Description
1	150	520	890042	Transporter
	150	620	890043	Transporter
	150	720	890044	Transporter
	150	820	890045	Transporter
	200	520	890372	Transporter
	200	620	890373	Transporter
	200	720	8 9 0 374	Transporter
	200	820	890375	Transporter
	150	ALL	890072	Transporter
	200	ALL	890379	
2	150	ALL	890062	Mount Shaft
	200	ALL	890 376	Transporter Mount Shaft
3	ALL	ALL	890551	Multi-Belt Roller
	150	ALL	890073	Multi-Belt Roller
4	200	ALL	890380	Flange Bearing
5	ALL	ALL	890058	Multi-Belt Roller Shaft
	ALL	ALL	890060	Multi-Belt Roller Shaft
	ALL	ALL	8 9 0 0 61	
6	ALL	ALL	890059	Multi-Belt Roller Bracket, Right Front
7	ALL	ALL	810108	Multi-Belt Roller Bracket, Left Front
8	ALL	ALL	866792	Multi-Belt Roller Bracket, Left Rear
9	ALL	ALL	8 6 9 5 61	Multi-Belt Roller Bracket, Right Rear
10	ALL	ALL	8 6 0 261	Belt, M8x30 Hex Head
11	ALL	520	866371	Washer, M8 Large OD
12	ALL	620	866373	Screw, M5-0.8x25 Hex Head
13	ALL	720	8 6 7 115	Nut, M5 Lock
14	ALL	820	868642	Transporter Belt
	ALL	ALL	890063	Transporter Belt
	ALL	ALL	890 076	Transporter Belt
	150	ALL	890446	Transporter Belt
	200	ALL	890548	
	150	ALL	8 6 6 411	
15	200	ALL	868716	Transporter Multi-Belt Roller Timing Gear
16				Transporter Timing Belt
17				Belt Guard
				Belt Guard
				Blow-On Tube
18				Blow-On Tube

# Transfer Belt Assembly, 520-820mm Diagram

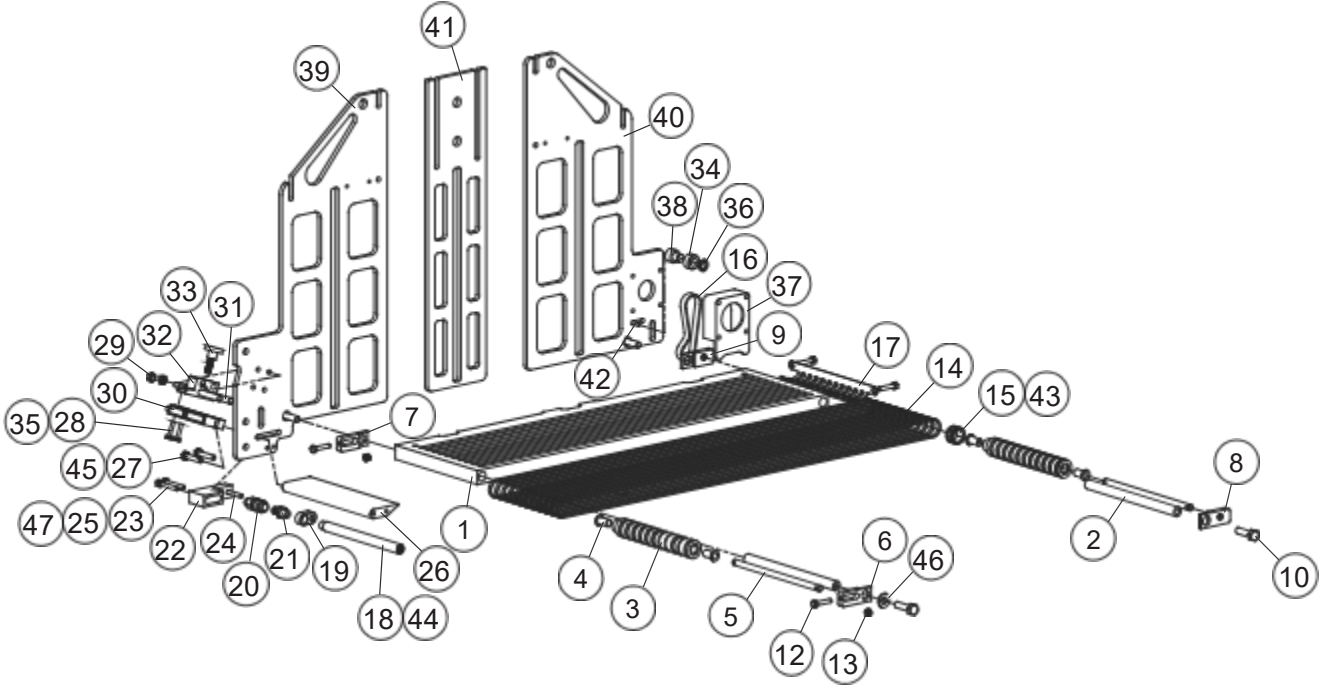

# Transfer Belt Assembly, 520-820mm (continued)

## Parts List

Item No.	Label Width	Chassis Width		Description
19	ALL	ALL	866 412	Blow-On Angle Adjuster
20	ALL	ALL	866572	Quick Coupling Socket, G1/8
21	ALL	ALL	866649	Quick Coupling Plug, G1/8
22	ALL	ALL	890070	Blow-On Tube Mount
23	ALL	ALL	890508	Bolt, M4x40 Hex Head
24	ALL	ALL	866701	Dowel Pin, 5mm x 50mm
25	ALL	ALL	866772	Washer, 4mm Flat
26	150	ALL	890069	Peel Bar
	200	ALL	890378	Peel Bar
	ALL	ALL	8670 03	
	ALL	ALL	81010 0	
27	ALL	ALL	866765	Bolt, M6x30 Hex Head
28	ALL	ALL	8693 41	Bolt, M4x20 Hex Head
29	ALL	ALL	895350	Nut, M6-1.0 Hex
30	150	ALL	890 067	Photo Sensor, SICK
	200	ALL	890399	Photo Sensor, Clear Label
	ALL	ALL	890068	
31	ALL	ALL	890258	Photoeye Mount Shaft
	ALL	ALL	866 410	Photoeye Mount Shaft
32	ALL	ALL	866772	Mount Block, Photo Sensor, 2mm Gap
33	ALL	ALL	866801	Thumb Screw
34	ALL	ALL	890075	Fan Box Idler Roller
35	ALL	ALL	890077	Washer, 4mm Flat
36	ALL	ALL	890065	Retaining Ring, External 12mm
37	ALL	ALL	890064	Motor Mount, Transporter
38	ALL	ALL	890425	Belt Tensioner for Transporter
39	ALL	ALL	810102	Tamp Back Plate, Right-Hand
40	ALL	ALL	890593	Tamp Back Plate, Left-Hand
41	ALL	ALL	866834	Tamp Back Plate, Center
42	ALL	ALL	866774	Screw, M5x12 Hex Head
43	ALL	ALL	866447	Roll Pin, 1.5 x 8
44	ALL	ALL	866783	Set Screw, M10x10
45				Washer, M6 Flat
46				Fan Mount Washer - ONLY ON FRONT
47				Washer, 4mm Split

# Transfer Belt Assembly, 520-820mm (continued) Diagram

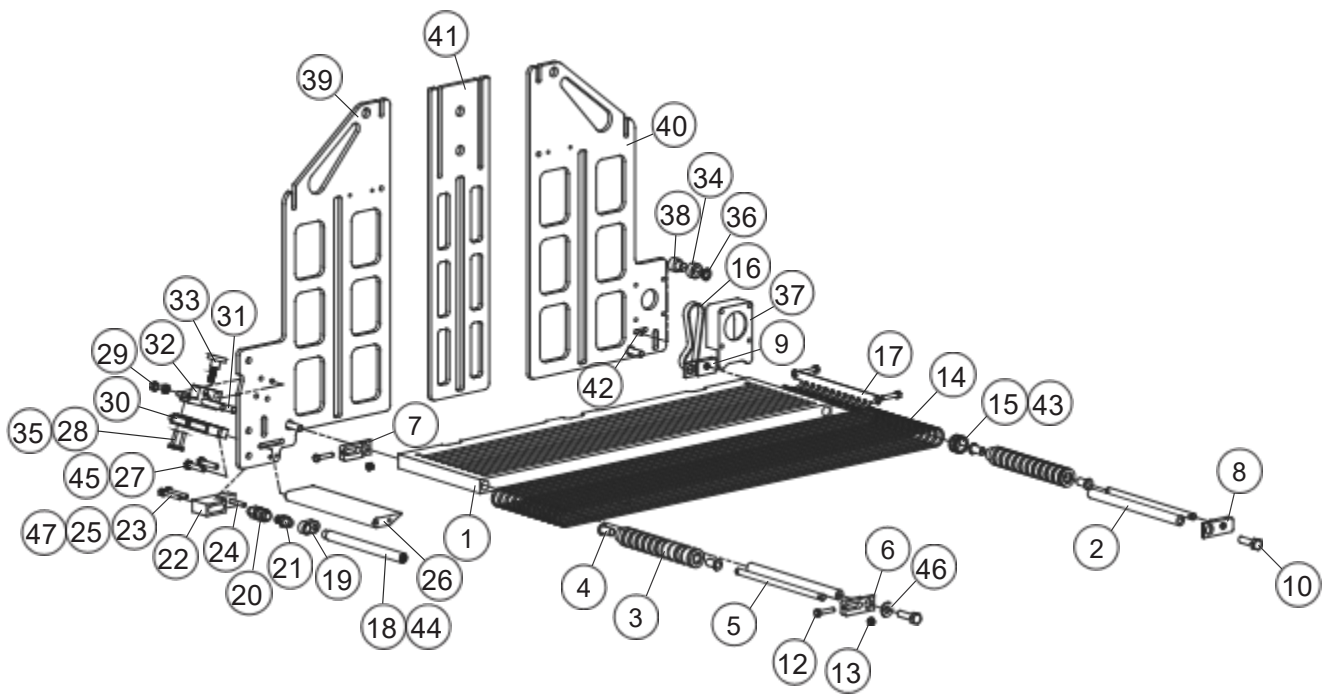

# Push Blade, 320mm, Shielded

## Parts List

Item No.	Label Width		Description
1	150	890833	Plate, Top Fan
	200	890862	Plate, Top Fan
2	150	890066	Tamp Carrier Brace
	200	890377	Tamp Carrier Brace
	ALL	8 9 0 176	
3	ALL	866569	Cylinder, Tamp, 32x200mm
	ALL	890529	Fitting, 90 Deg Tamp Cylinder Connection
4	ALL	890831	Fan, 172mm, 24VDC, 281 c.f.m.
5	ALL	869329	Guard, Modified, Fan, Plastic
6	ALL	869328	Screw, M4x70 Slotted Pan Head
7	ALL	866774	Screw, M4x60 Slotted Pan Head
8	ALL	8670 03	Washer, 6mm Flat
9	150	8 9 0 811	Bolt, M6x30 Hex Head
10	200	890854	Fan Box Shield
	ALL	890 8 41	Fan Box Shield
	ALL	866706	
	ALL	866791	
11	ALL	890802	Guard, Internal
12	ALL	890800	Bolt, M4x10 Flat Head
13	150	890828	Washer, 5mm Flat Large OD
14	200	890870	Nut, M6 Rivet
15	ALL	860256	Insert, M6 Press-In
16	ALL	860260	Bar, Tamp Unit
	ALL	890829	Bar, Tamp Unit
	ALL	890803	
17	ALL	890827	Screw, M5x12 Slotted Pan Head
18	150	890464	Washer, 5mm Split
19	200	869379	Spacer Bar, Tamp Unit Blades
20	ALL	86678 4	Tamp Blade
21	ALL		Spacer, Tamp Blade
22	ALL		Bolt, M6x130 Hex Head
	ALL		Bolt, M6x185 Hex Head
23			Washer, 6mm Split
24		866 765	Nut, M6 Hex
25		890 819	Guard, Fan Box
26		868597	Screw, M6x20 Slotted Pan Head

# Push Blade, 320mm, Shielded Diagram

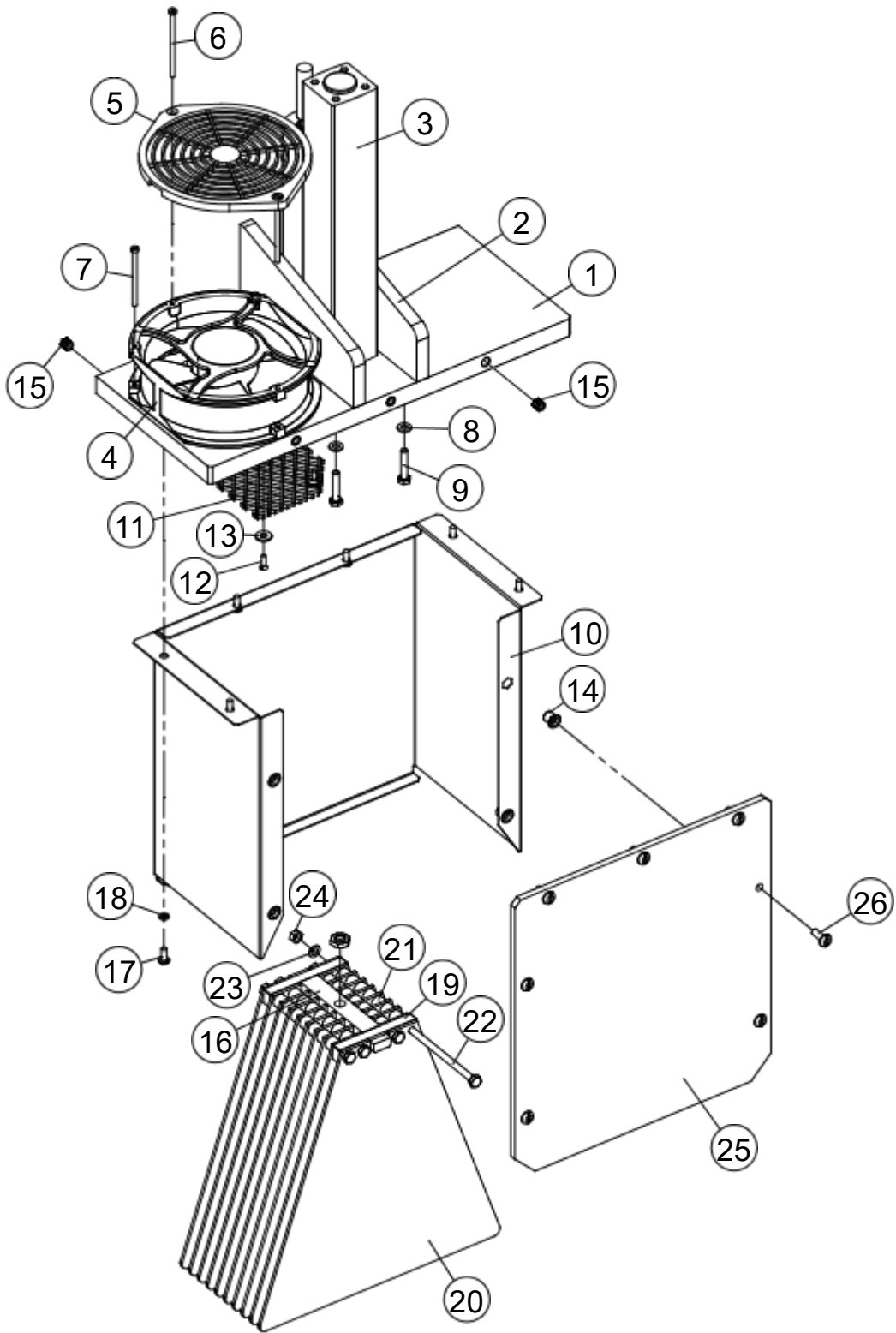

# Push Blade, 420-520mm, Shielded

## Parts List

Item No.	Label Width	Chassis Width		Description
1	150	420	890834	Plate, Top Fan
	150	520	890835	Plate, Top Fan
	200	420	890863	Plate, Top Fan
	200	520	890864	Plate, Top Fan
	150	ALL	890066	
2	200	ALL	890377	Tamp Carrier Brace
	ALL	ALL	8 9 0176	Tamp Carrier Brace
3	ALL	ALL	866569	Cylinder, Tamp, 32x200mm
	ALL	ALL	890529	Fitting, 90 Deg Tamp Cylinder Connection
	ALL	ALL	890831	
4	ALL	ALL	869329	Fan, 172mm, 24VDC, 281 c.f.m.
5	ALL	ALL	869328	Guard, Modified, Fan, Plastic
6	ALL	ALL	866774	Screw, M4x70 Slotted Pan Head
7	ALL	ALL	8670 03	Screw, M4x60 Slotted Pan Head
8	150	420	890 812	Washer, 6mm Flat
9	150	520	890 813	Bolt, M6x30 Hex Head
10	200	420	890855	Fan Box Shield
	200	520	890856	Fan Box Shield
	150	ALL	890828	Fan Box Shield
	200	ALL	890870	Fan Box Shield
	ALL	ALL	890829	
11	ALL	420	890404	Bar, Tamp Unit
	ALL	520	890805	Bar, Tamp Unit
	ALL	ALL	866765	
12	ALL	ALL	890827	Spacer Bar, Tamp Unit Blades
13	150	ALL	890464	Tamp Blade
	200	ALL	869379	Tamp Blade
14	ALL	ALL	86678 4	Nut, M6 Hex
15	ALL	ALL	890802	Spacer, Tamp Blade
	ALL	420	890820	
16	ALL	520	890 821	Bolt, M6x130 Hex Head
	ALL	ALL	868597	Bolt, M6x185 Hex Head
17	ALL	ALL	890800	Washer, 6mm Split
18	ALL	ALL	890055	Nut, M6 Rivet
19	ALL	ALL	866783	Guard, Fan Box
				Guard, Fan Box
20				Screw, M6x20 Slotted Pan Head
21				Insert, M6 Press-In
22				Fan Guard
23				Washer, 4mm Split

# Push Blade, 420-520mm, Shielded Diagram

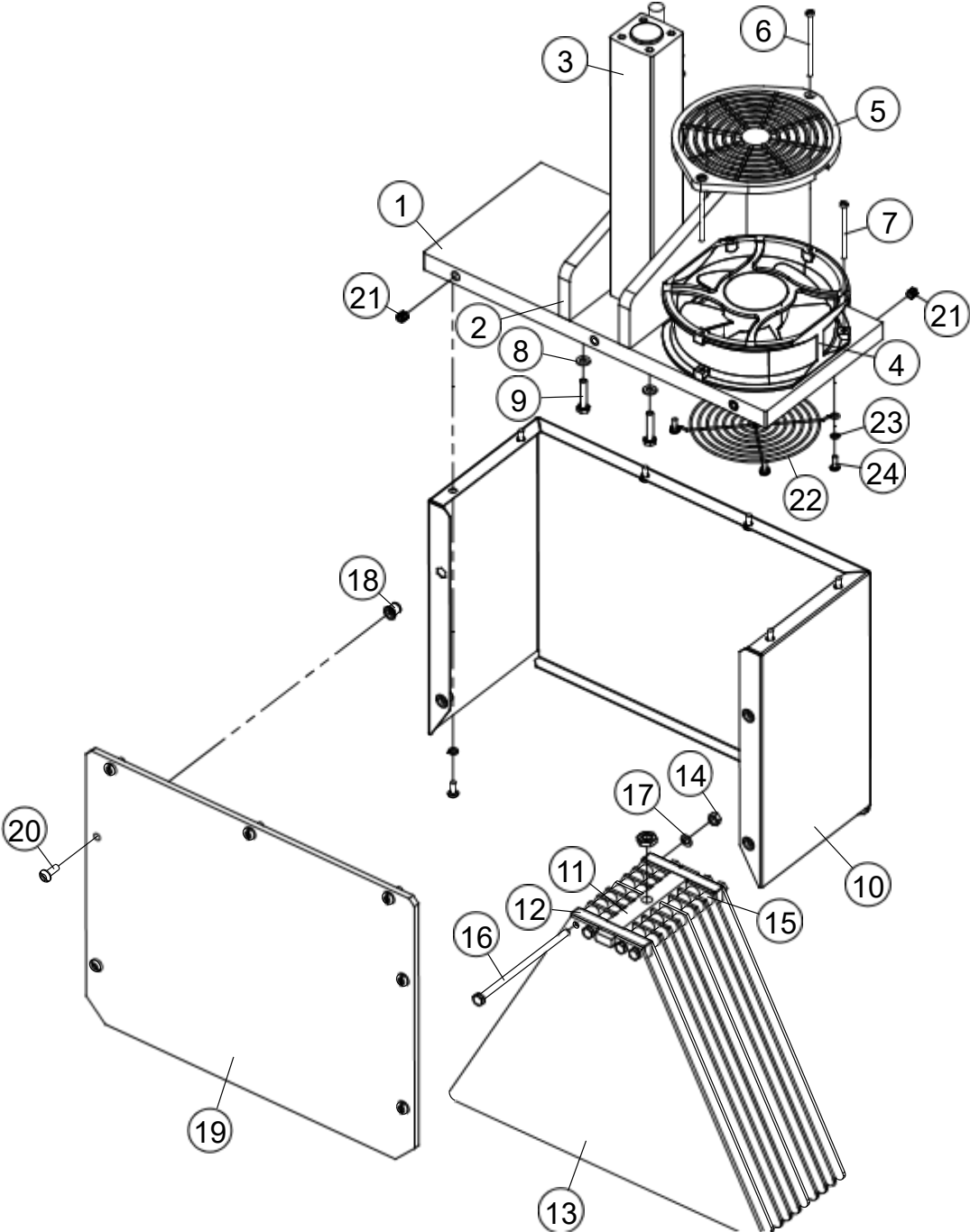

# Push Blade, 620-820mm, Shielded

## Parts List

Item No.	Label Width	Chassis Width		Description
1	150	620	890836	Plate, Top Fan
	150	720	890837	Plate, Top Fan
	150	820	890838	Plate, Top Fan
	200	520	890864	Plate, Top Fan
	200	620	890865	Plate, Top Fan
	200	720	890866	Plate, Top Fan
	200	820	890 867	Plate, Top Fan
	150	ALL	890066	
2	200	ALL	890377	Tamp Carrier Brace
	ALL	ALL	8 9 0176	Tamp Carrier Brace
	ALL	ALL	866569	
3	ALL	ALL	890529	Cylinder, 32 x 200mm
	150	620	890 814	Fitting, 90 Deg Tamp Cylinder Connection
4	150	720	890 815	Fan, 172mm, 24VDC, 281 c.f.m.
5	150	820	890 816	Shield, Fan Box
	200	520	890856	Shield, Fan Box
	200	620	890857	Shield, Fan Box
	200	720	890858	Shield, Fan Box
	200	820	890859	Shield, Fan Box
	ALL	620	890822	Shield, Fan Box
	ALL	720	890823	Shield, Fan Box
	ALL	820	890824	
	150	ALL	890828	
6	200	ALL	890870	Guard, Fan Box
	ALL	ALL	890829	Guard, Fan Box
	ALL	620	890806	Guard, Fan Box
7	ALL	720	890807	Bar, Tamp Unit to Cylinder
	ALL	820	890808	Bar, Tamp Unit to Cylinder
	ALL	ALL	890827	
8	150	ALL	890464	Spacer Bar, Tamp Unit Blades
9	200	ALL	869379	Tamp Blade
	ALL	ALL	866774	Tamp Blade
	ALL	ALL	866765	Tamp Blade
10	ALL	ALL	890831	Spacer, Tamp Blade
11				Bolt, M6x130 Hex Head
				Bolt, M6x185 Hex Head
12				Washer, 6mm Flat
13				Nut, M6 Hex
14				Guard, Fan, Plastic

# Push Blade, 620-820mm, Shielded Diagram

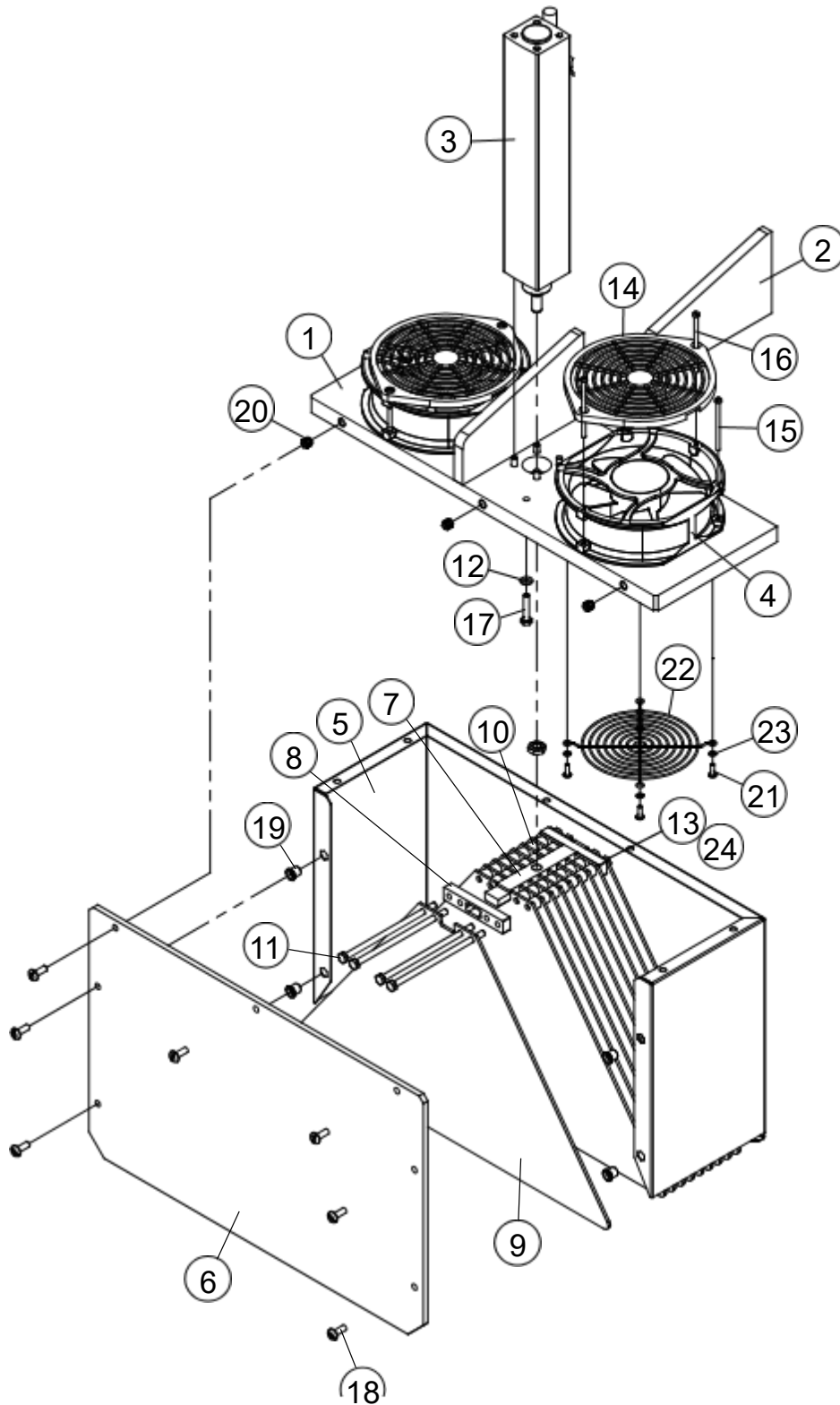

## Push Blade, 620-820mm, Shielded (continued)

### Parts List

Item No.	Label Width	Chassis Width		Description
15	ALL	ALL	869328	Screw, M4x60 Slotted Pan Head
16	ALL	ALL	869329	Screw, M4x70 Slotted Pan Head
17	ALL	ALL	8670 03	Bolt, M6x30 Hex Head
18	ALL	ALL	868597	Screw, M6x20 Slotted Pan Head
19	ALL	ALL	890802	Nut, M6 Rivet
20	ALL	ALL	890800	Insert, M6 Press-In
21	ALL	ALL	860270	Screw, M4x12 Cheese Head
22	ALL	ALL	890055	Fan Guard
23	ALL	ALL	866783	Washer, 4mm Split
24	ALL	ALL	86678 4	Washer, 6mm Split

# Push Blade, 620-820mm, Shielded (continued) Diagram

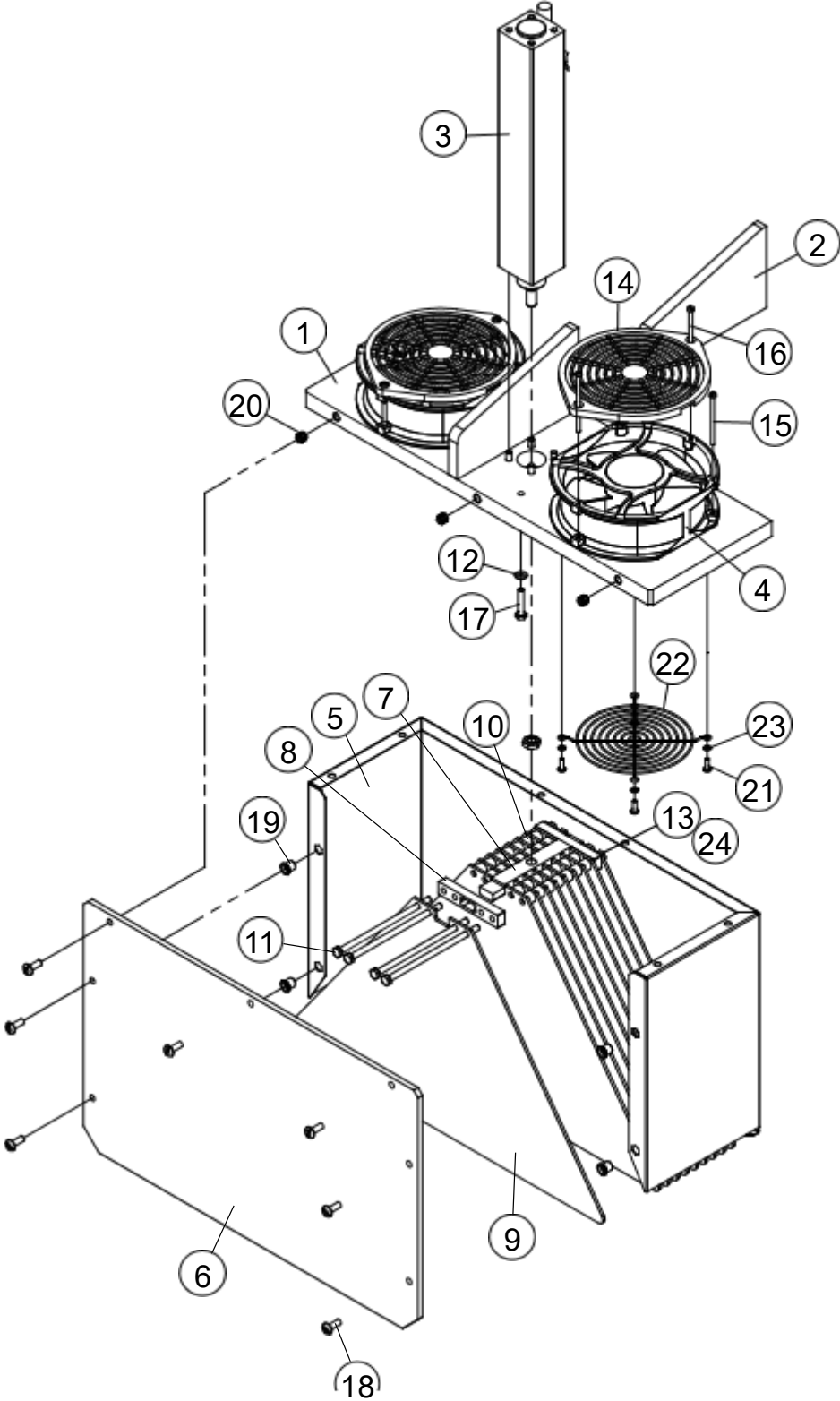

# Twin Tower Option

## Parts List

Item No.	Label Width		Description
1	ALL	867386	Plate, Twin Tower Side
2	ALL	866064	Bearing, Ball, 32x15x9
3	150	890023	Main Dispense Roller Axle
	200	8 9 0 361	Main Dispense Roller Axle
	ALL	866802	
4	150	895010	Retaining Ring, External, 15mm
5	200	8 9 5 011	Idler Roller, 2-in. Nominal
	150	895004	Idler Roller, 2-in. Nominal
6	200	895005	Dancer Arm Assembly
	ALL	890424	Dancer Arm Assembly
	150	890102	
7	200	890382	Spring Mount Spindle
8	ALL	890104	Main Dispense Roller
	ALL	8 6 6121	Main Dispense Roller
9	ALL	865004	Spacer, Unwind Shaft
10	ALL	867388	Spring, Dancer Arm
	ALL	867389	Assembly, Label Disc
11	ALL	867391	Base, Twin Tower
12	ALL	867390	Gimble, Twin Tower
13	ALL	8 6 674 3	Washer, Thrust
	ALL	866777	Bearing, Thrust
14	ALL	8 674 61	Bolt, M12x80, SS, Socket Head
15	ALL	835258	Washer, Flat, 12mm
	ALL	8 9 0 017	Nut, Hex, Nyloc, M12x2
16	ALL	866824	Knob, Spring Plunger
17	ALL	892038	Adapter, Shaft Extension
18	ALL	866775	Set Screw, M8x40 Socket
19	ALL	890025	Bolt, M8x25 Hex Head
20	ALL	890024	Washer, Flat, 8mm
	ALL	867387	Bearing Spacer, Dancer Arm
21	ALL	867392	Spacer, Main Dispense Roller Mount
22			Plate, Twin Tower Center
23			Back Plate, Package/Film
24			
25			
26			
27			

# Twin Tower Option Diagram

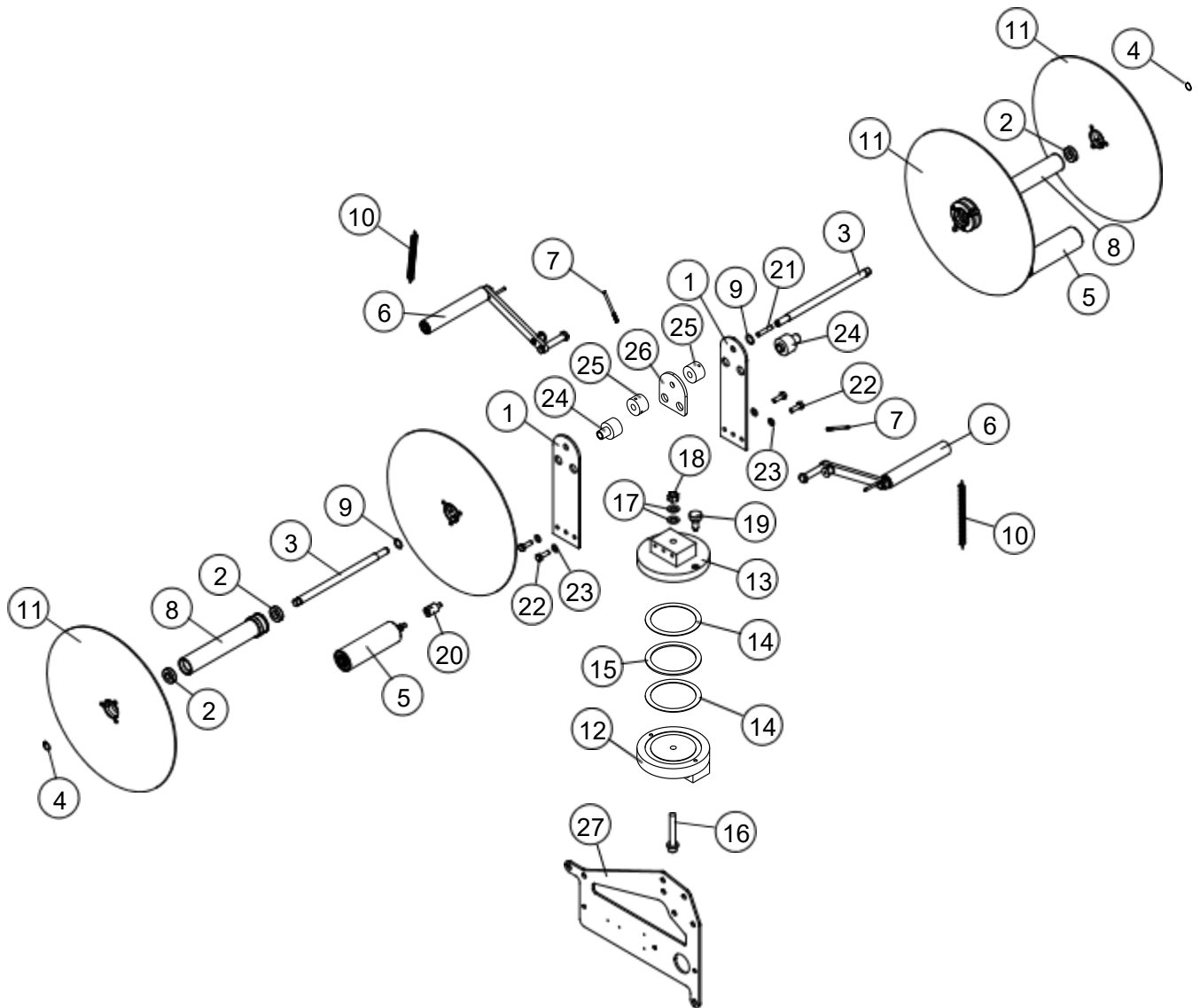

# Chassis Assembly

## Parts List and Diagram

Item No.	Chassis Width		Description
1	ALL	890000	Chassis Tube Block
2	320	890191	Package Chassis Tube Assembly
	420	890192	Package Chassis Tube Assembly
	520	890193	Package Chassis Tube Assembly
	620	890194	Package Chassis Tube Assembly
	720	890195	Package Chassis Tube Assembly
	820	890196	Package Chassis Tube Assembly
	ALL	890146	
3	ALL	890097	Chassis Mount Block, for Tamp Unit
4	ALL	890101	Loom Block Base
5	ALL	800350	Valve Mount Plate
6	ALL	890550	Bolt, M4x10 Hex Head
7	ALL	890549	Screw, M8x30 Flat Socket Head
8			Slot Head Female Threaded Fastener

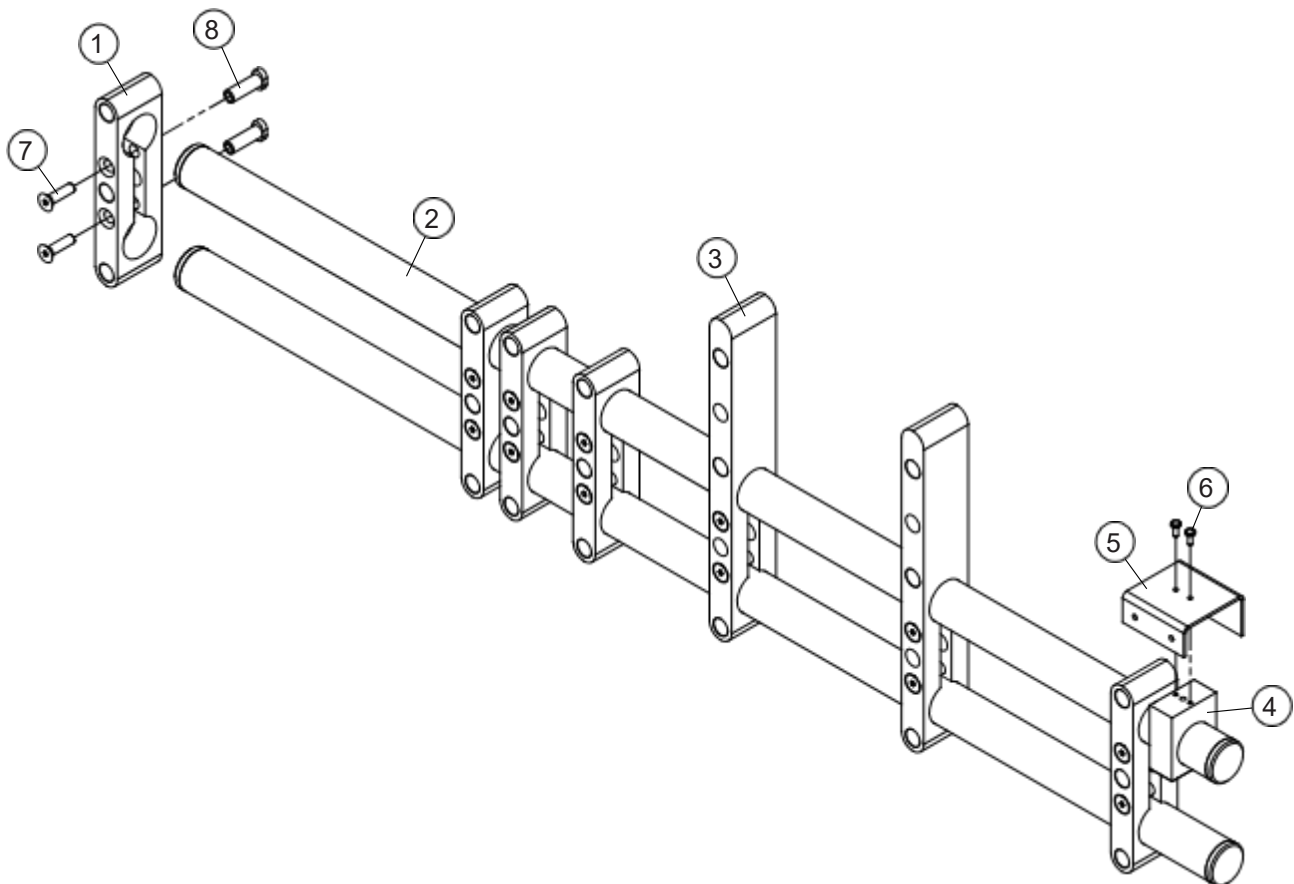

# Longitudinal Shift Assembly

## Parts List and Diagram

Item No.		Description
1	895036	Carriage Linear Assembly, Left-Hand
	895037	Carriage Linear Assembly, Right-Hand
2	890730	Carriage Sensor Block
3	860255	Screw, M5x6 Slotted Flathead
4	890440	Bolt, M5x16 Hex Head
5	866778	Washer, 5mm Star
6	895042	Belt Clamp Assembly, Longitudinal
7	890731	Lock Block for Shifting Locator

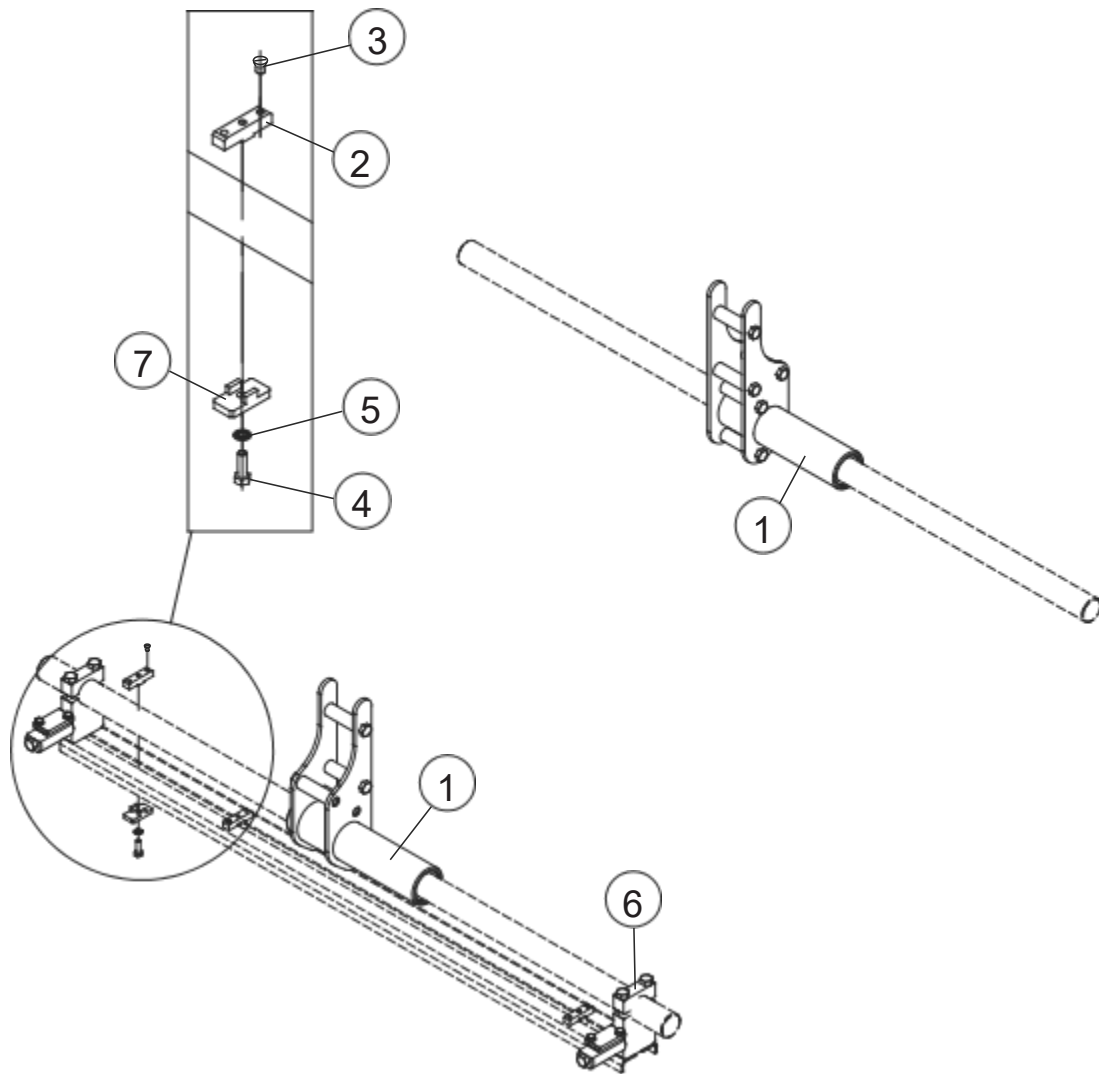

# Carriage Drive Assembly

## Parts List

Item No.		Description
1	890 081	Longitudinal Drive Plate
2	866623	Timing Belt Pulley, HTD-5, 44T
3	866620	Timing Belt Pulley, 20T
4	866390	Idler Sleeve
5	866396	Drive Axle
6	890082	Carriage Drive Bearing Housing
7	866392	Bearing, 17x35x10
8	866015	Bearing, 12x28x8
9	890083	Longitudinal Drive Side Plate
10	866562	Belt, HTD-5, 330x15
11	810108	Bolt, M8x30 Hex Head
12	890084	Screw Extension on Longitudinal Drive
13	890086	Horizontal Drive Post
14	810105	Bolt, M6x25 Hex Head
15	86678 4	Washer, 6mm Split
16	866792	Washer, 8mm Large OD
17	810107	Bolt, M8x20 Hex Head
18	890087	Drive Post Containment Block
19	81010 0	Bolt, M4x20 Hex Head
20	810103	Bolt, M5x20 Hex Head
21	866773	Washer, 5mm Flat
22	866801	Retaining Ring, External, 12mm
23	866563	Carriage Drive Belt, HTD-5, 1270x25
	890546	Carriage Drive Belt, HTD-5, 1750x25
	890237	Sensor Home
	8 6 67 11	
	866812	
	866813	
	890140	
24	890147	
25	866774	Screw, M3x10 Slotted Pan Head
26	810142	Key, 5x5x20
27	866628	Key, 5x5x16
28	866790	Longitudinal Drive Side Plate
29		Guard, Longitudinal Drive Belts
30		Washer, 6mm Flat
31		Bolt, M6x12 Hex Head
32		Washer, Gearbox Head
33		Washer, 4mm Large OD

# Carriage Drive Assembly Diagram

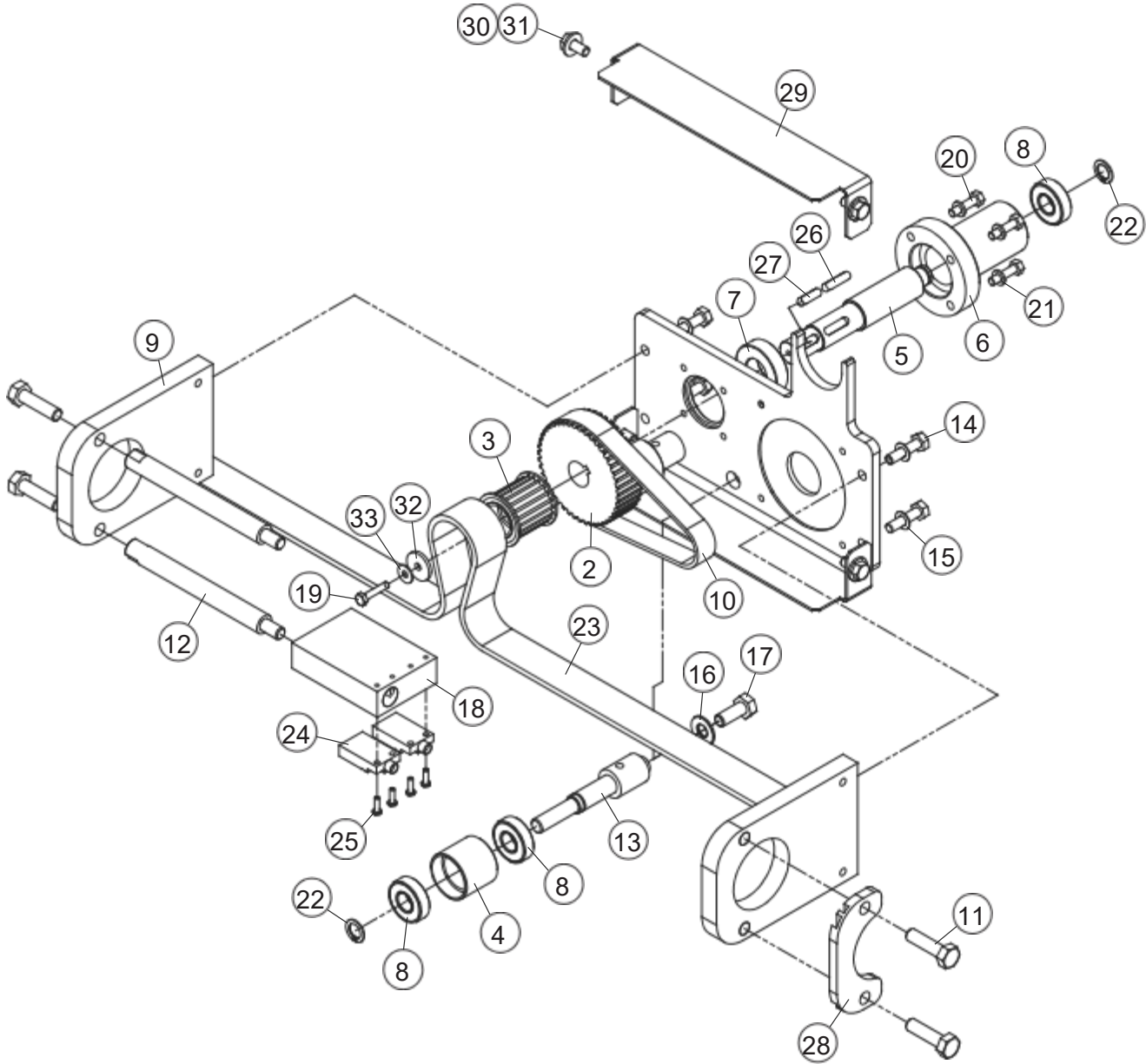

# Carriage Bearing Assembly

## Parts List and Diagram

Item No.		Description
1	890 031	Bearing Tube Mount Plate
2	890003	Tapped Insert for Drive Head
3	810107	Bolt, M8x20 Hex Head
4	8 9 5119	Bearing Tube Assembly

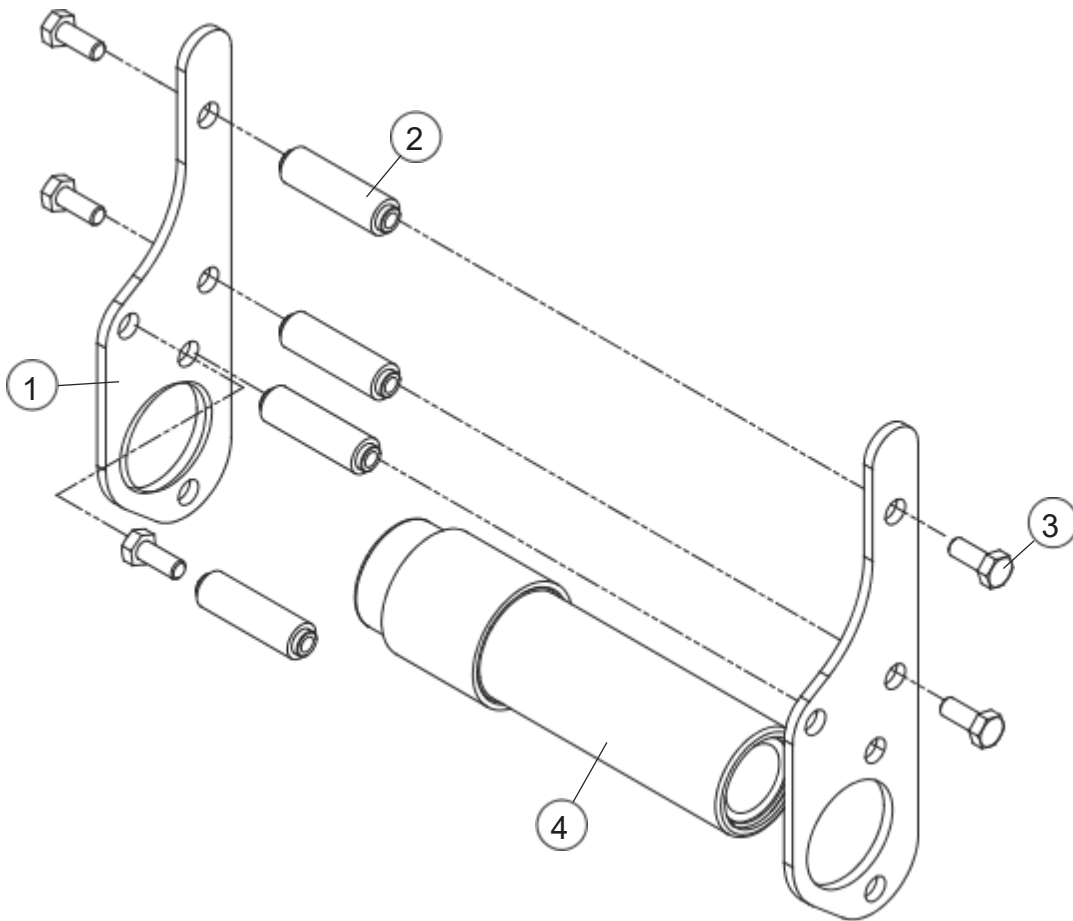

# Bearing Tube Assembly

## Parts List and Diagram

Item No.		Description
1	890032	Carriage Bearing Bar Assembly
2	866387	Linear Ball Bushing
3	866807	Retaining Ring, Internal, 40mm

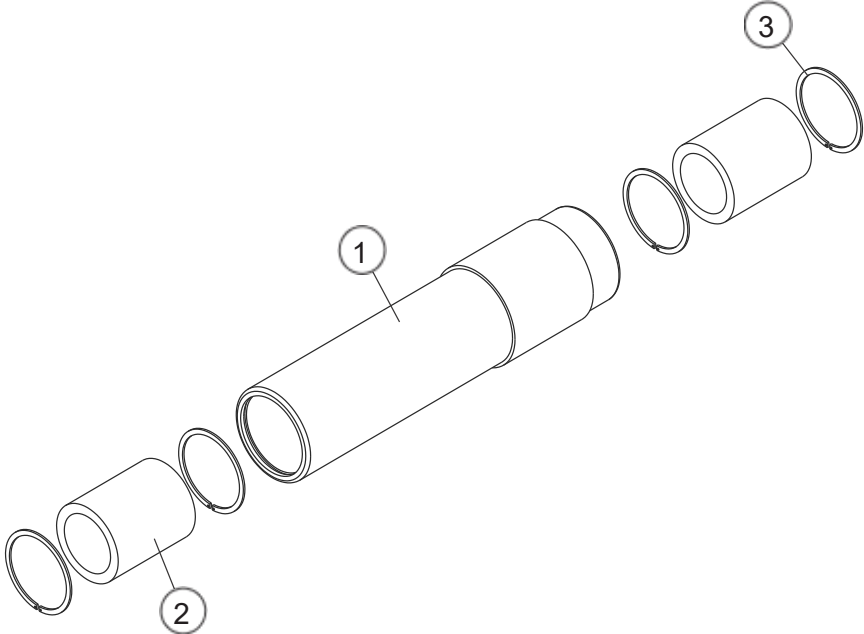

# Carriage Belt Clamp Assembly

## Parts List and Diagram

Item No.		Description
1	890135	Carriage Rail Lower Clamp
2	890138	Carriage Belt Post
3	890137	Carriage Belt Lock Plate
4	810103	Bolt, M5x20 Hex Head
5	866778	Washer, 5mm Star
6	890136	Carriage Rail Upper Clamp
7	890143	Bolt, M8x70 Hex Head
8	890504	Bolt, M8x40 Hex Head
9	810147	Bolt, M6x10 Hex Head
10	86678 4	Washer, 6mm Split

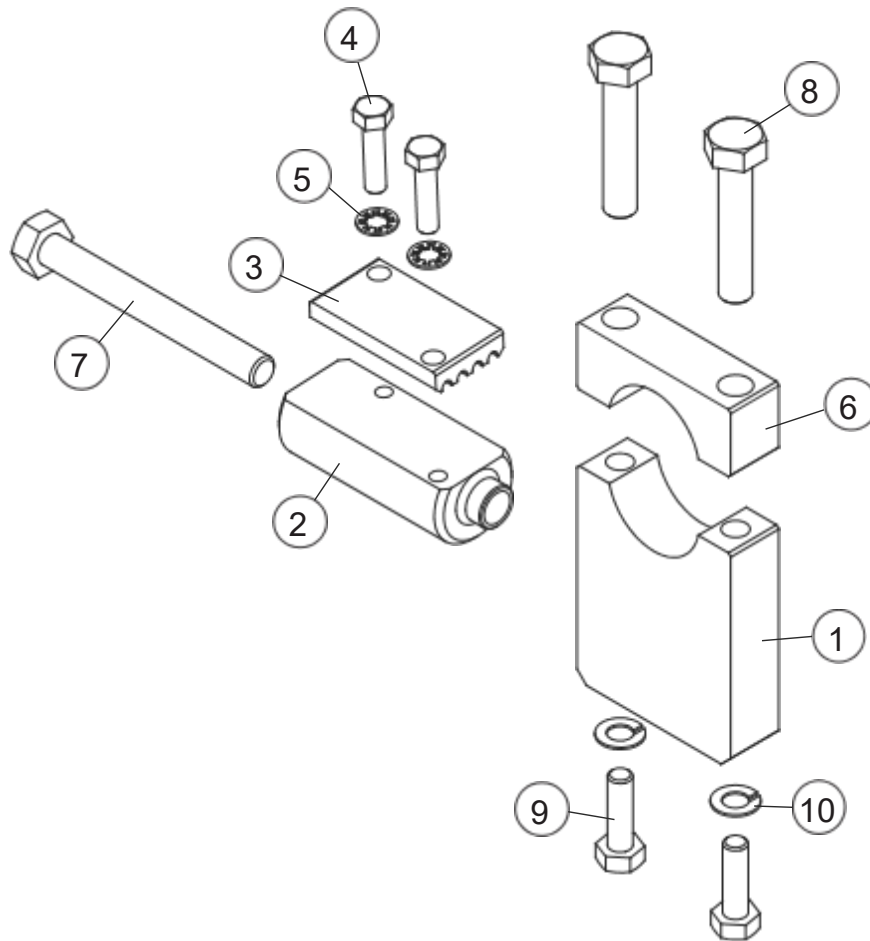

# Label Reel

## Parts List and Diagram

Item No.		Description
1	8 6 6117	Label Roll Locking Hug
2	869345	Cam Arm, Unwind Disc
3	86670 0	Dowel Pin, SS, 3mm x 20mm
4	8 6 6116	Unwind Label Roller Disc, 14-in.
	867141	Unwind Label Roller Disc, 18-in.
	86670 8	
5	866763	Screw, M4x20 Slotted Flat Head
6		Nut, 4mm Hex

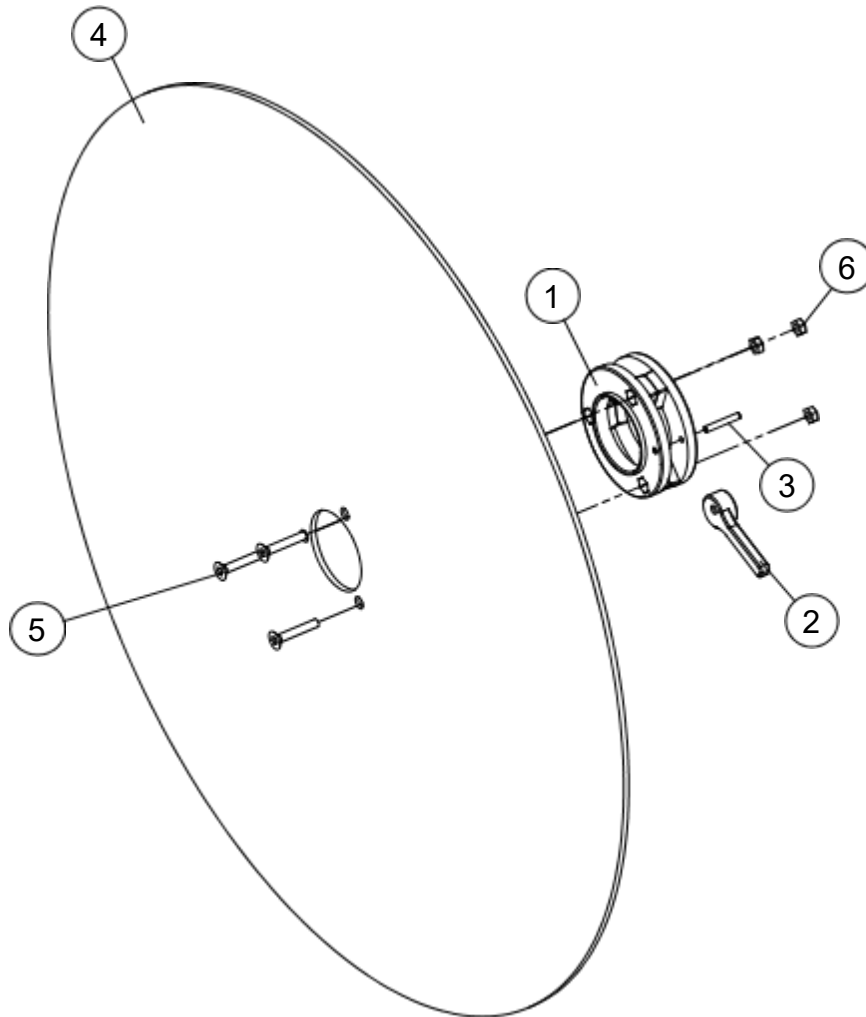

# Idler Roller Set Assembly

## Parts List and Diagram

Item No.	Label Width		Description
1	ALL	890003	Tapped Insert for Drive Head
2	150	895010	Idler Roller Assembly, 2-in.
	200	8 9 5 0 1 1	Idler Roller Assembly, 2-in.
	ALL	810107	
3	150	895012	Bolt, M8x20 Hex Head
4	200	895013	Idler Roller Assembly, 1.25-in.
	ALL	890095	Idler Roller Assembly, 1.25-in.
5			Large Washer for Mounting Blocks

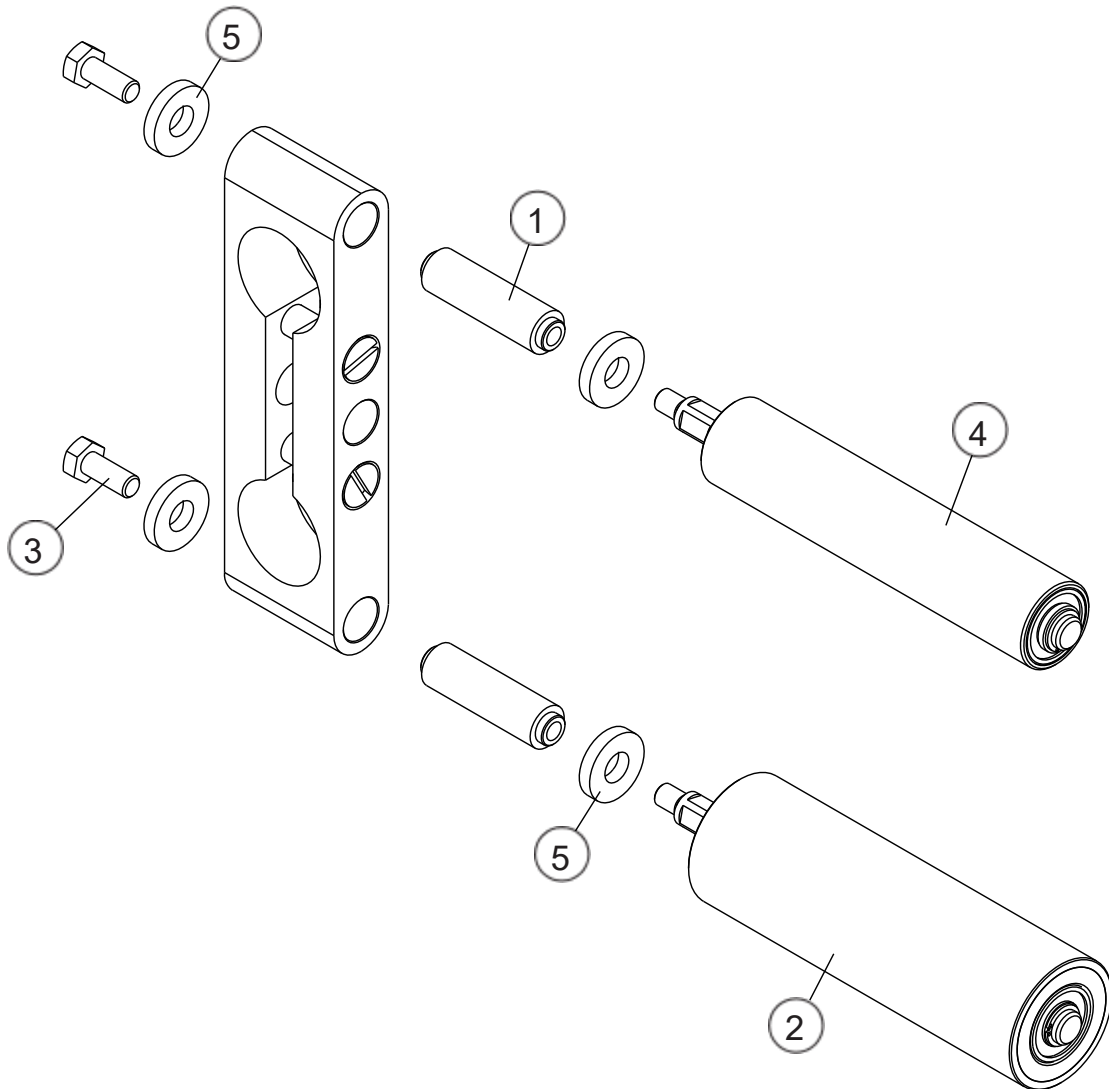

# Idler Roller Assembly, 2-in.

## Parts List and Diagram

Item No.	Label Width		Description
	150	895010	Idler Roller Assembly
	200	8 9 5 011	Idler Roller Assembly
1	150	890 021	Axle, Drive Head Roller
	200	890360	Axle, Drive Head Roller
	ALL	866801	
2	ALL	866048	Retaining Ring, External, 12mm
3	ALL	890020	Bearing, 28x12x8
4	150	890 019	Hub for 2-in. Idler Roller
5	200	890359	Idler Roller
	ALL	890729	Idler Roller
6			O-Ring Spacer for Idler Roller

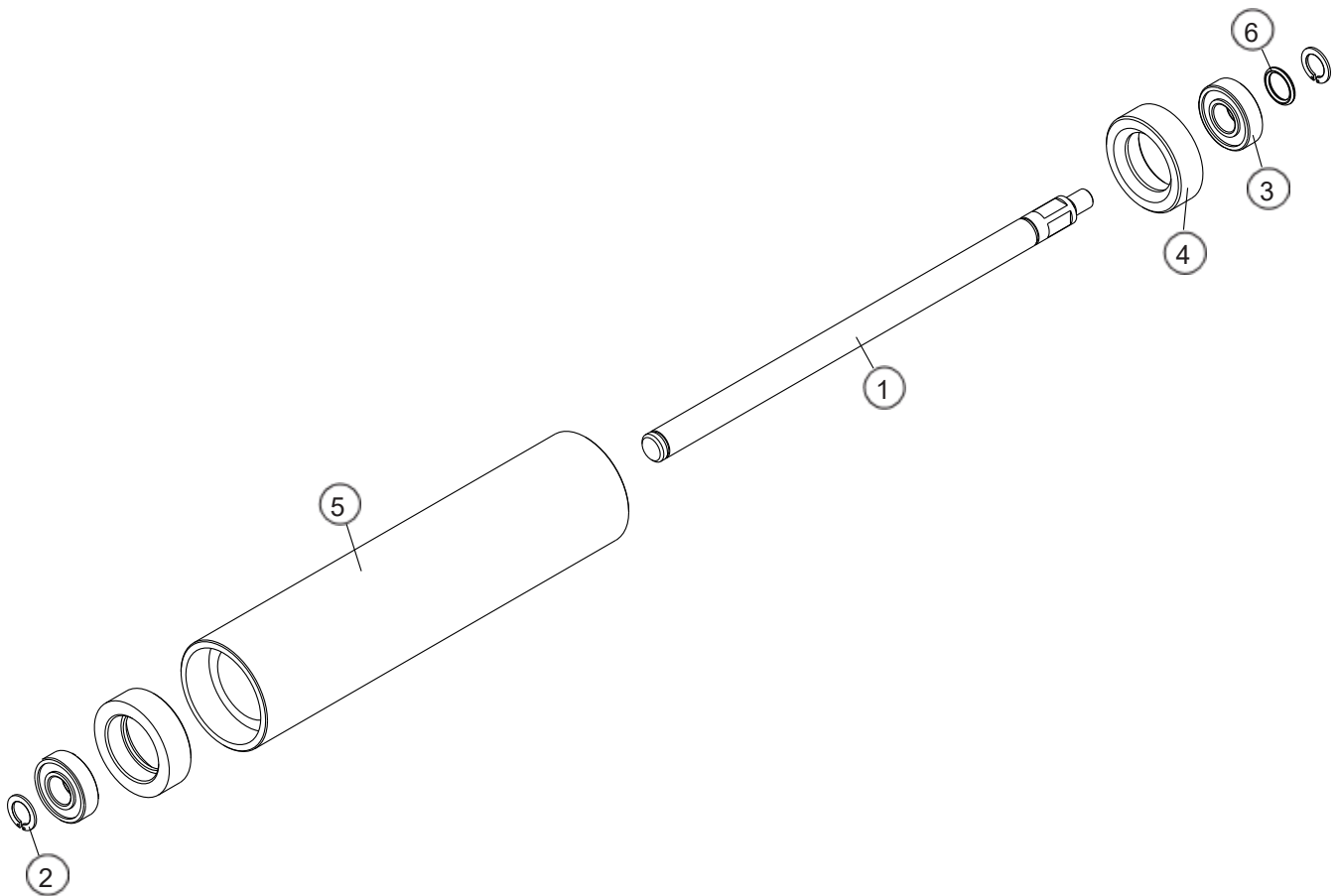

# Idler Roller Assembly, 1.25-in.

## Parts List and Diagram

Item No.	Label Width		Description
	150	895012	Idler Roller Assembly
	200	895013	Idler Roller Assembly
1	150	890 021	Axle, Drive Head Roller
	200	890360	Axle, Drive Head Roller
	ALL	866801	
2	ALL	866048	Retaining Ring, External, 12mm
3	150	890 019	Bearing, 28x12x8
4	200	890359	Idler Roller
	ALL	890729	Idler Roller
5			O-Ring Spacer for Idler Roller

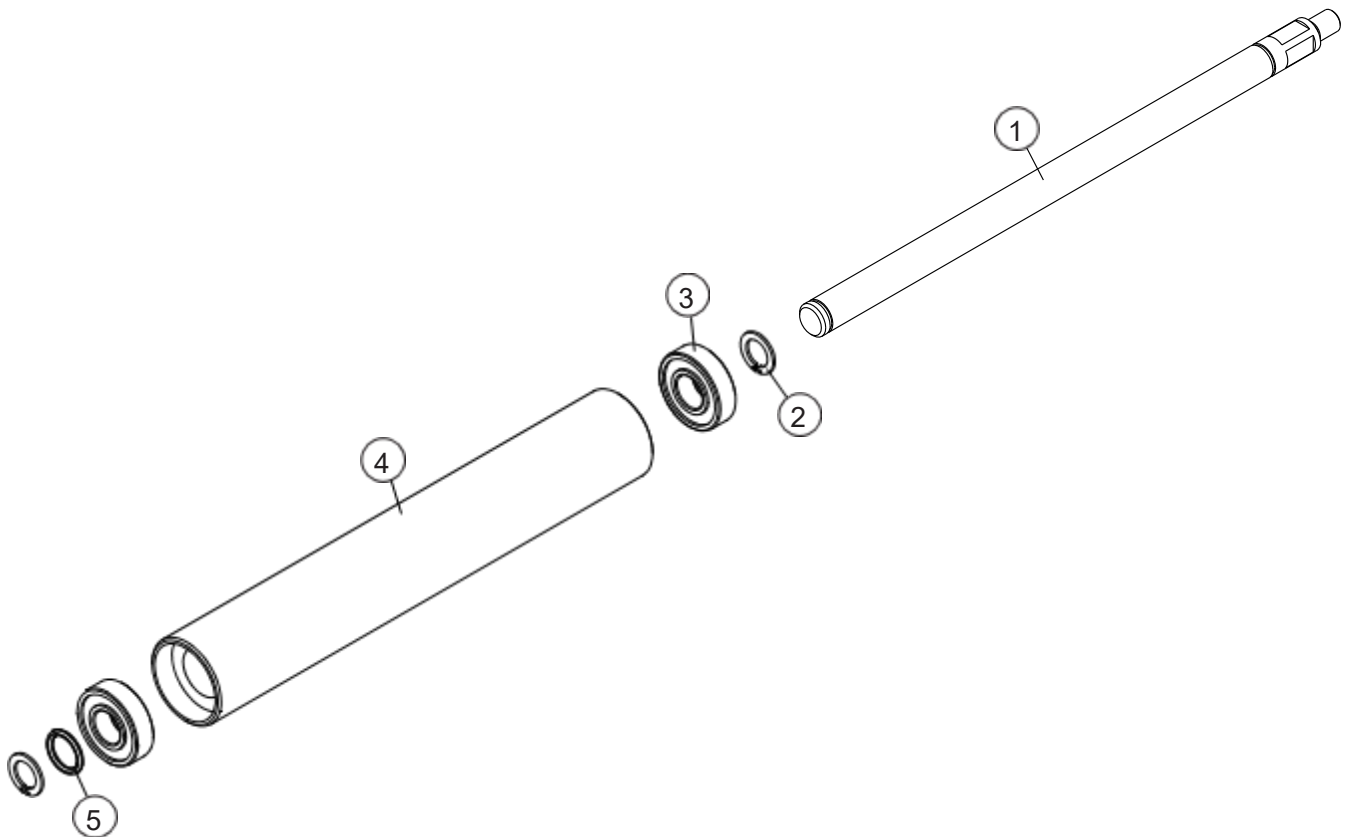

# Super-Torque Label Head/Shift Motor

## Parts List and Diagram

Item No.		Description
	895020	Super-Torque Label Head Motor, Complete Assembly (white)
	895021	Super-Torque Shift Motor, Complete Assembly
1	89198 4	White Stepper Motor, Super-Torque Applications
2	890501	Timing Belt Pulley, Keyed, 18T
3	890447	Spacer for Label Head Motor
	890502	Spacer for Shift Motor (not shown)
	891987	
4	869024	Plate, Motor End Cover
5	810143	Key, 3/16x3/16x 5/8, S S
6	866793	Screw, M6x20 Hex Head
7	86678 4	Washer, 6mm Large OD
8	860296	Washer, 6mm Split
9	860260	Screw, M5x35 Hex Head
11		Washer, 5mm Spring Lock

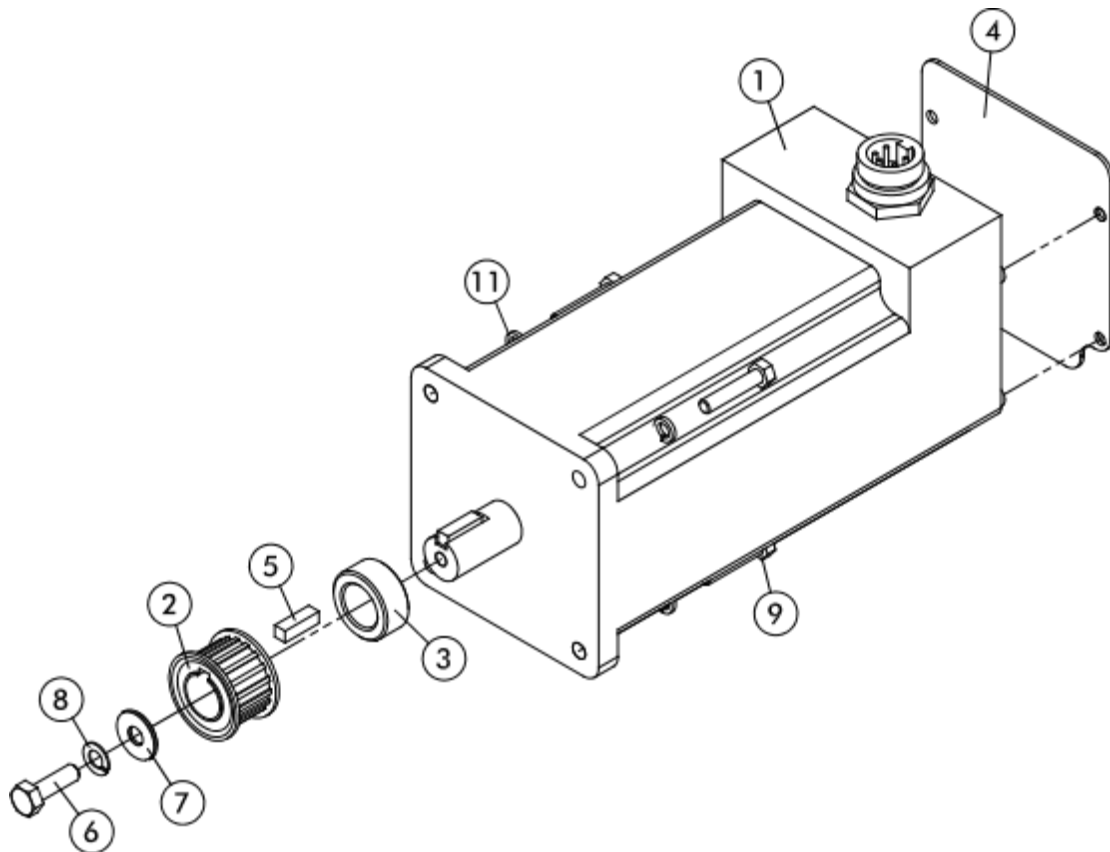

# High- and Standard-Torque Label Head/Shift Motor

## Parts List and Diagram

Item No.		Description
	895022	High-Torque Label Head/Shift Motor, Complete Assembly (red)
	895023	Standard-Torque Label Head/Shift Motor, Complete Assembly (black)
1	891985	Red Stepper Motor, High-Torque Applications
	8914 46	Black Stepper Motor, Standard-Torque Applications
	866626	
2	866399	Timing Belt Pulley, 18T
3	800350	Shaft Lock Clamp (3/8)
4	890440	Screw, M4-0.7x10 Hex Head
5	860260	Bolt, M5x16 Hex Head
6	890583	Washer, M5 Split
7		Motor End Cover Plate

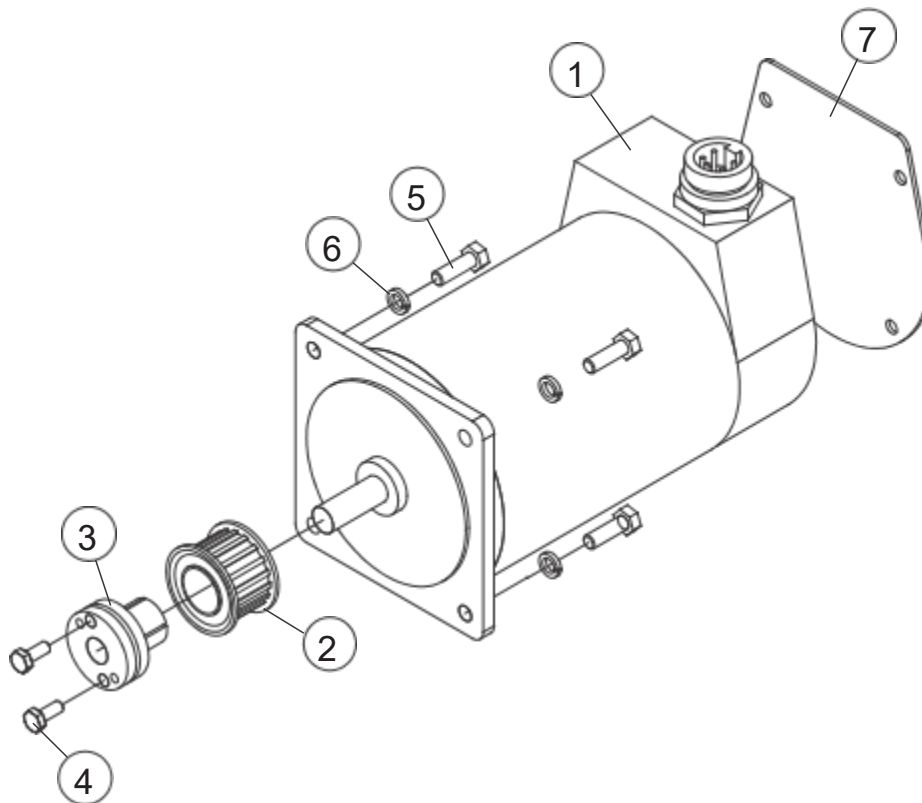

# High- and Standard-Torque Transport/Package Motor

## Parts List and Diagram

Item No.		Description
	895018	High-Torque Transport/Package Motor, Complete Assembly (red)
	895024	Standard-Torque Transport/Package Motor, Complete Assembly (black)
1	891986	Red Stepper Motor, High-Torque Applications
	8-9117-1	Black Stepper Motor, Standard-Torque Applications
	866279	
2	8 9 0 074	Clamp Set, 1/4-in.
3	860286	Transport Motor Timing Pulley
4	866773	Bolt, M5x40 Hex Head
5	8 6 67 11	Washer, 5mm Flat
6		Screw, M3x10 Slotted Pan Head

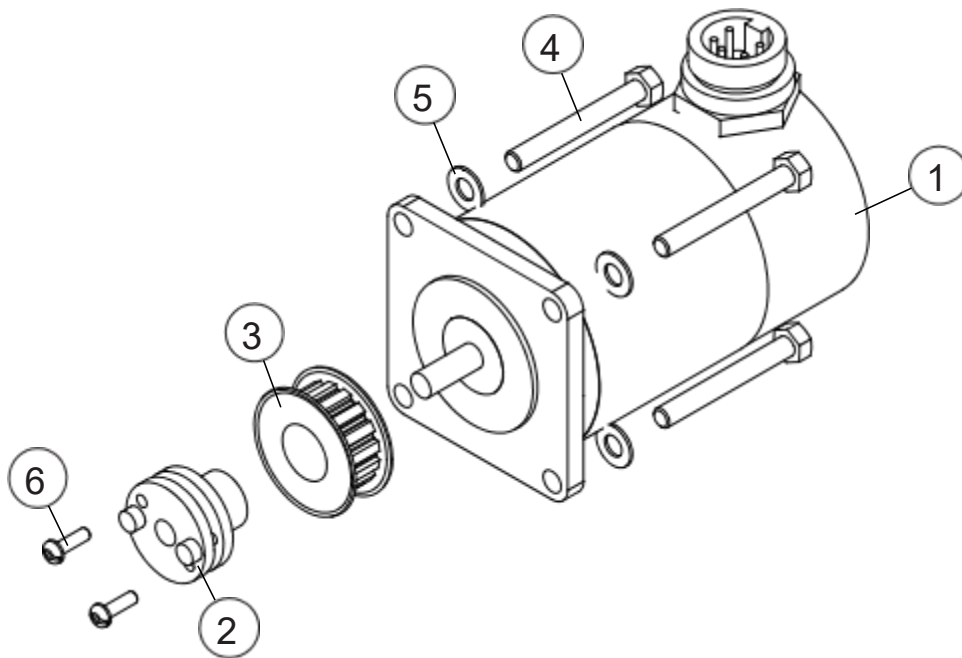

# Servo Motor Assembly

## Parts List and Diagram

Item No.		Description
	895584	Servo Motor Assembly
1	869668	Motor, Servo
2	8 69741	Timing Belt Pulley, 18T
3	8 6974 2	Swedge Lock, 1/2"
4	810104	Bolt, M5x25 Hex Head
5	860260	Washer, M5
6	869603	Servo Shaft Safety
7	890547	Collar Clamp, 30x54x15
8	866829	Bolt, M3x5 Pan Head
9	866829	Bolt, M4x10 Hex Head

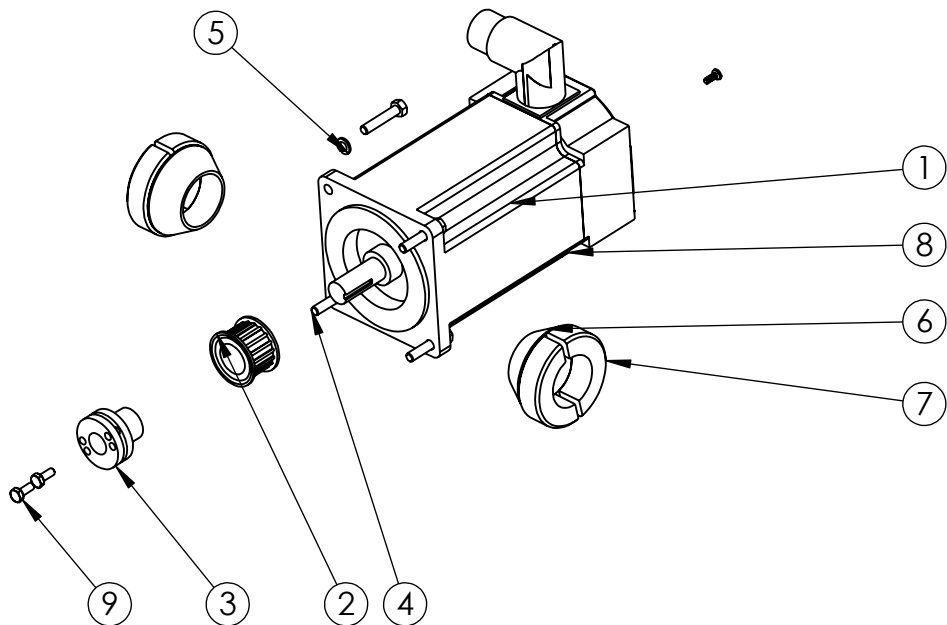

# Servo Safety Guard

## Parts List and Diagram

Item No.		Description
	869571	Servo Safety Guard Assembly
1	869584	Block, Mount
2	869577	Safety Bar
3	890922	Bolt, M8x80 Hex Head
4	869583	Safety Switch, Omron
5	810108	Bolt, M8x30 Hex Head
6	867181	Nut, M8 Nylon Lock
7	810104	Screw, M5-0.8x25 Hex Head
8	866773	Washer, 5mm Flat

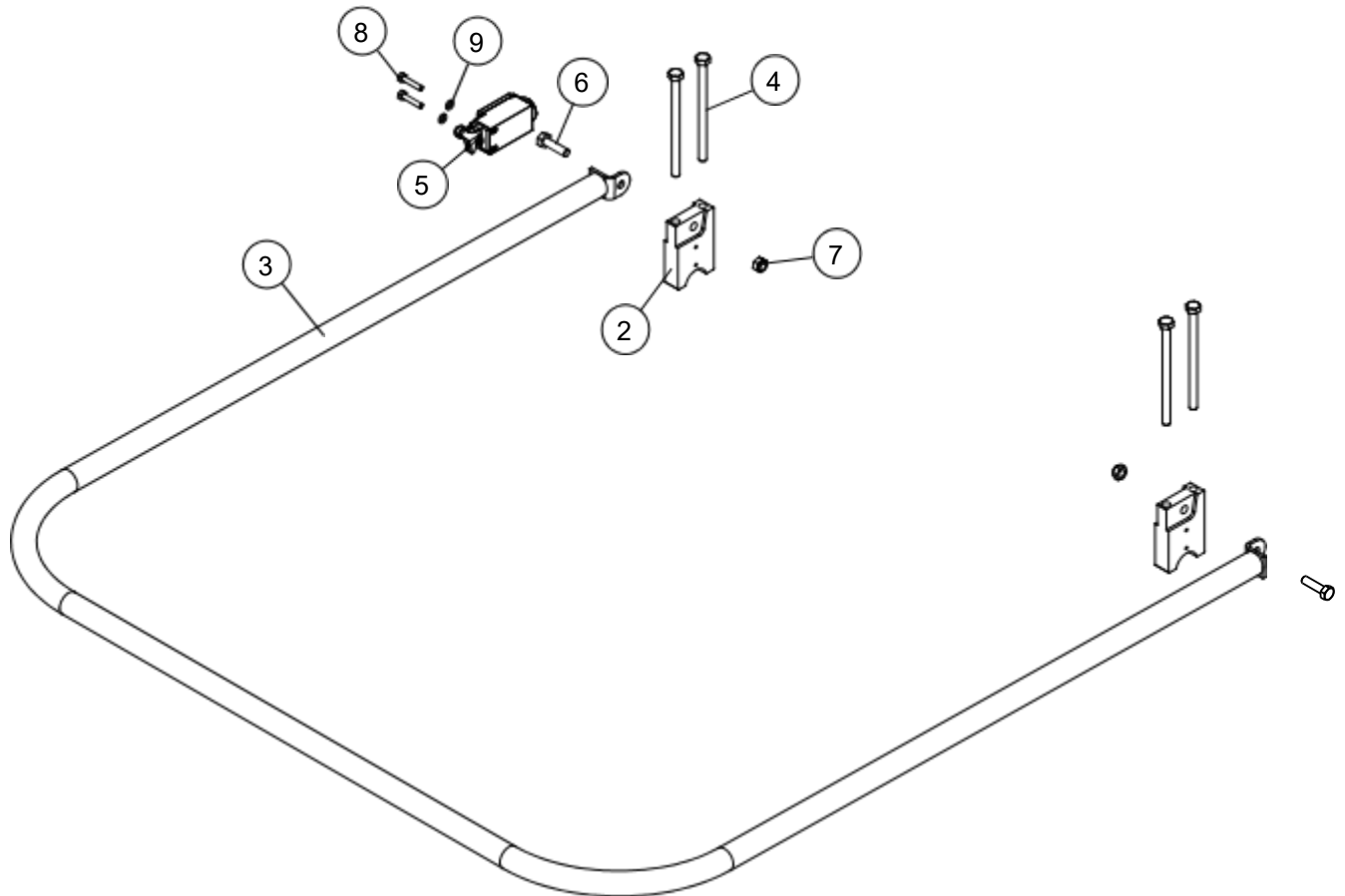

# Controls Loom Assembly

## Parts List and Diagram

Item No.		Description
	895370	Complete Assembly Controls Loom
1	890637	Loom Bracket, Controls
2	890638	Loom Clamp, Controls
3	810102	Bolt, M5x12 Hex Head
4	890640	Grommet, 1/4-in.
5	890643	Grommet, 9/32 in.

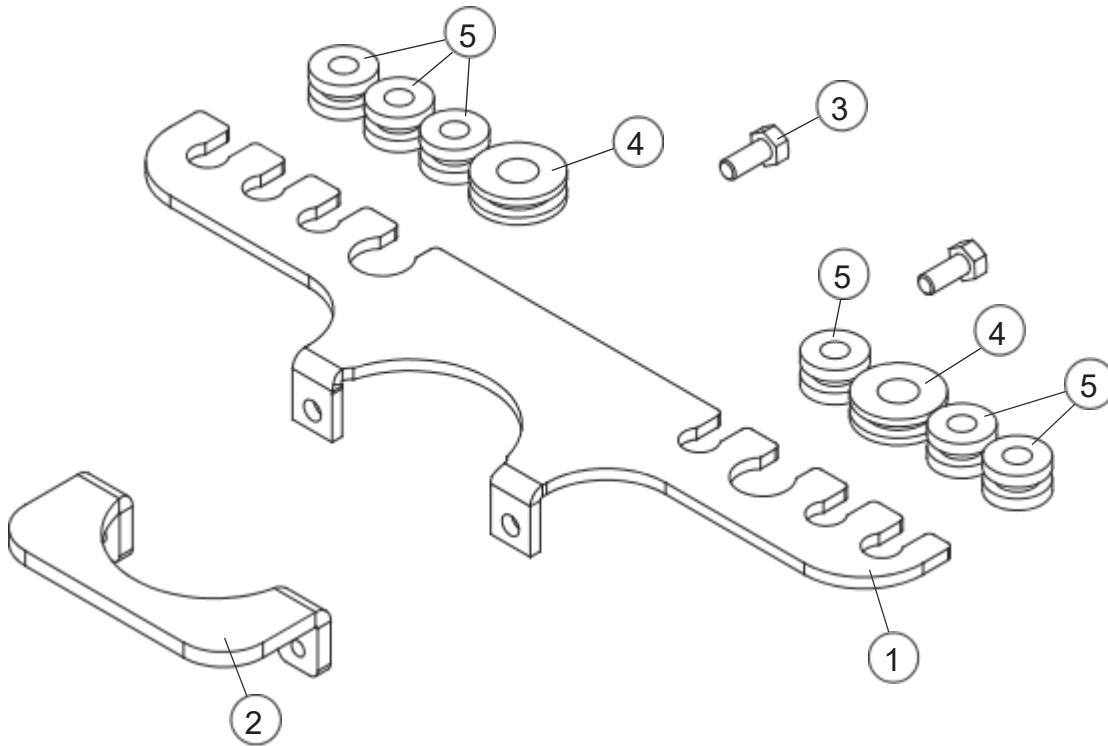

# Chassis Bracket Assembly

## Parts List and Diagram

Item No.		Description
1	890636	Cable Mounting Bracket
2	890640	Grommet, 1/4-in.
3	890643	Grommet, 9/32-in.

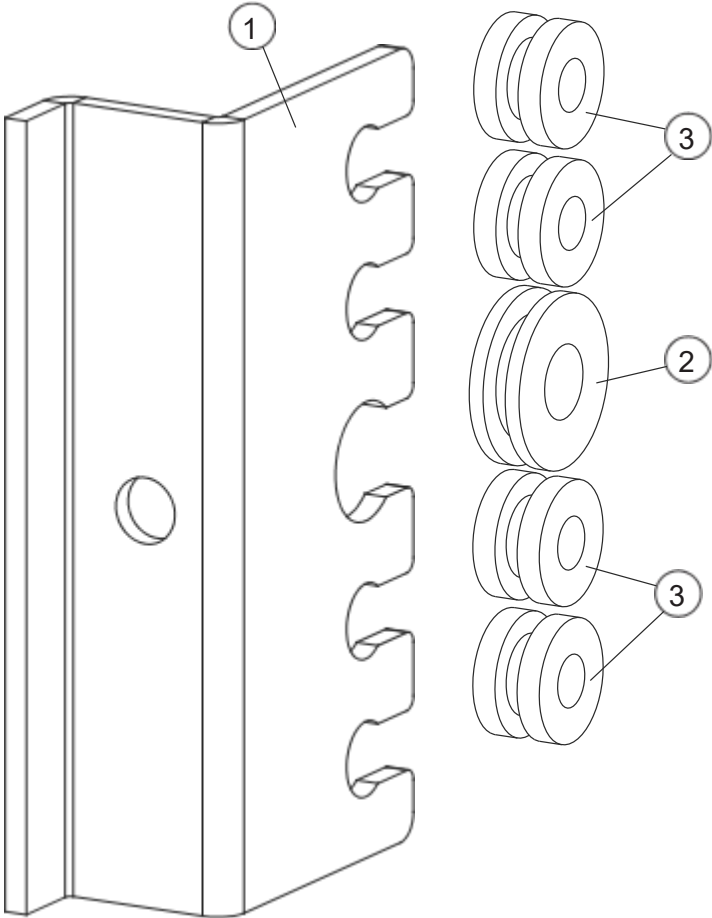

# Chassis Loom Assembly

## Parts List and Diagram

Item No.		Description
1	890634	Loom Bracket, Chassis
2	890643	Grommet, 1/4-in.
3	890 6 41	Grommet, 13/64-in.
4	890634	Loom Clamp, Chassis
5	810102	Bolt, M5x12 Hex Head

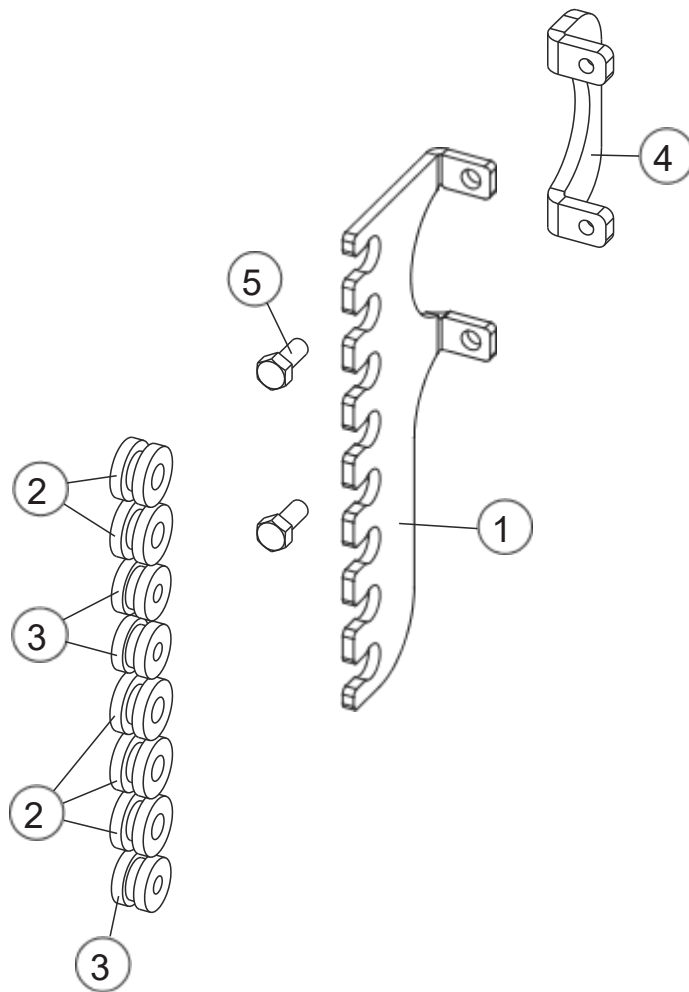

# Pneumatics Mounting Bracket Assembly

## Parts List and Diagram

Item No.		Description
1	800350	Bolt, M4x10 Hex Head
2	890097	Loom Block Base
3	890101	Valve Mount Plate
4	8 6 6761	Set Screw, M6x6

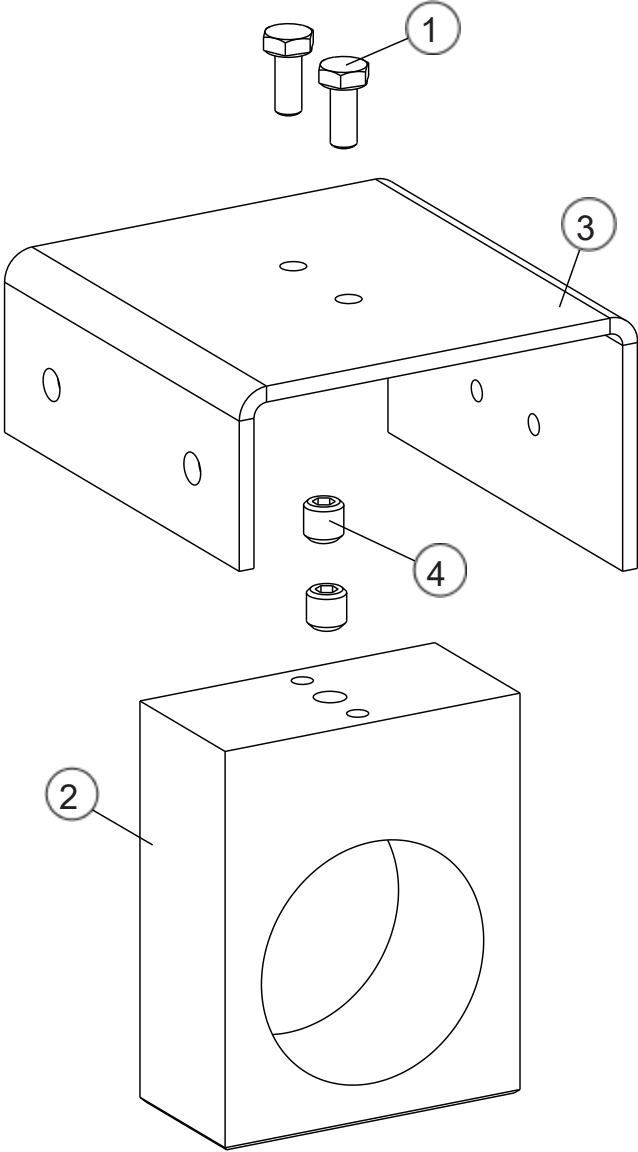

# Control Cabinet Assembly

## Parts List

Item No.		Description
1	869304	Cabinet, V3
2	869512	Touchscreen
	869567	Touchscreen, Extended Language Option
3	869514	Stepper Drive, ST10-S
4	8 6 8 1 1 8 860232	Power Supply, 75V
5	860281	Standoff, M4x50
6	869303	Nut, 4mm Lock
7	869509	Circuit Board Assembly (use with card option below)
	869510	Motion Card, Two (2) Stepper Motors, Programmed
	869316	Motion Card, Three (3) Stepper Motors, Programmed
	869315	
8	866600	Wire Duct
9	869316	Heat Sink
10	868384	Flange Clamp
11	869337	Rear Mount
12	869322	Heater/Thermostat, 100 Watt
13	869664	Cord Grip
14	868536	Decal, Rear
15	860321	Cable, Communication, Trio to Touchscreen (not shown)
16	869338	Switch and Body Assembly
17	869339	Light, Orange, 24VDC
18	866845	Decal, Front
19	866724	Washer, 4mm Flat Plastic
20	866714	Bolt, M4x16 SHCS
21	86678 0	Bolt, M4x10 SHCS
22	810143	Screw, M4x10 Pan Head
23	810109	Washer, 10mm Star
24	866781	Bolt, M6x12 Hex Head
25	8 6 8 1 1 4	Bolt, M10x25 Hex Head
26	890131	Washer, 6mm Star
27	890131	Nut, 1/2-in.-14 NPSM
28		Cable, Bulkhead, 5 Wire, Mini, Female
29		Cable, Bulkhead, 5 Wire, Mini, Female

# Control Cabinet Assembly Diagram

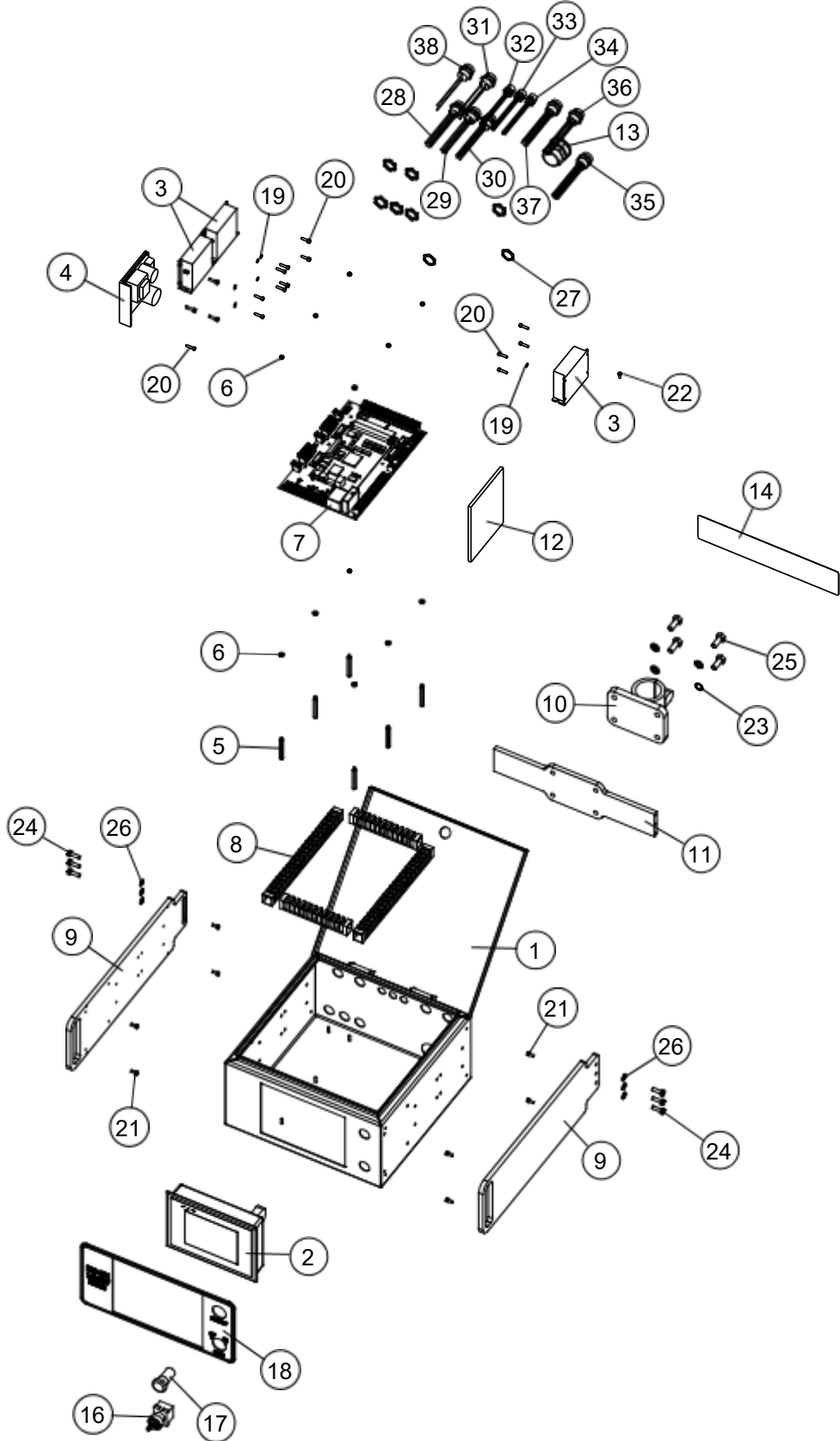

# Control Cabinet Assembly (continued)

## Parts List

<b>Item No.</b>		<b>Description</b>
30	890131	Cable, Bulkhead, 5 Wire, Mini, Female
31	868102	Cable, Bulkhead, 3 Wire, Male, Mini
32	868109	Cable, Bulkhead, 5 Wire, Female, Euro
33	8 6 8111	Cable, Turck, Bulkhead, 4, Female, Euro
34	8 6 8111	Cable, Turck, Bulkhead, 4, Female, Euro
35	890134	Cable, Bulkhead, "B", Multifast, Female
36	868104	Cable, Turck, Bulkhead, 6, Female, Mini
37	868106	Cable, Bulkhead, 6 Wire, Male, Mini
38	8 6 8113	Cable, Bulkhead, 2 Wire, Female, Mini

# Control Cabinet Assembly (continued)

## Diagram

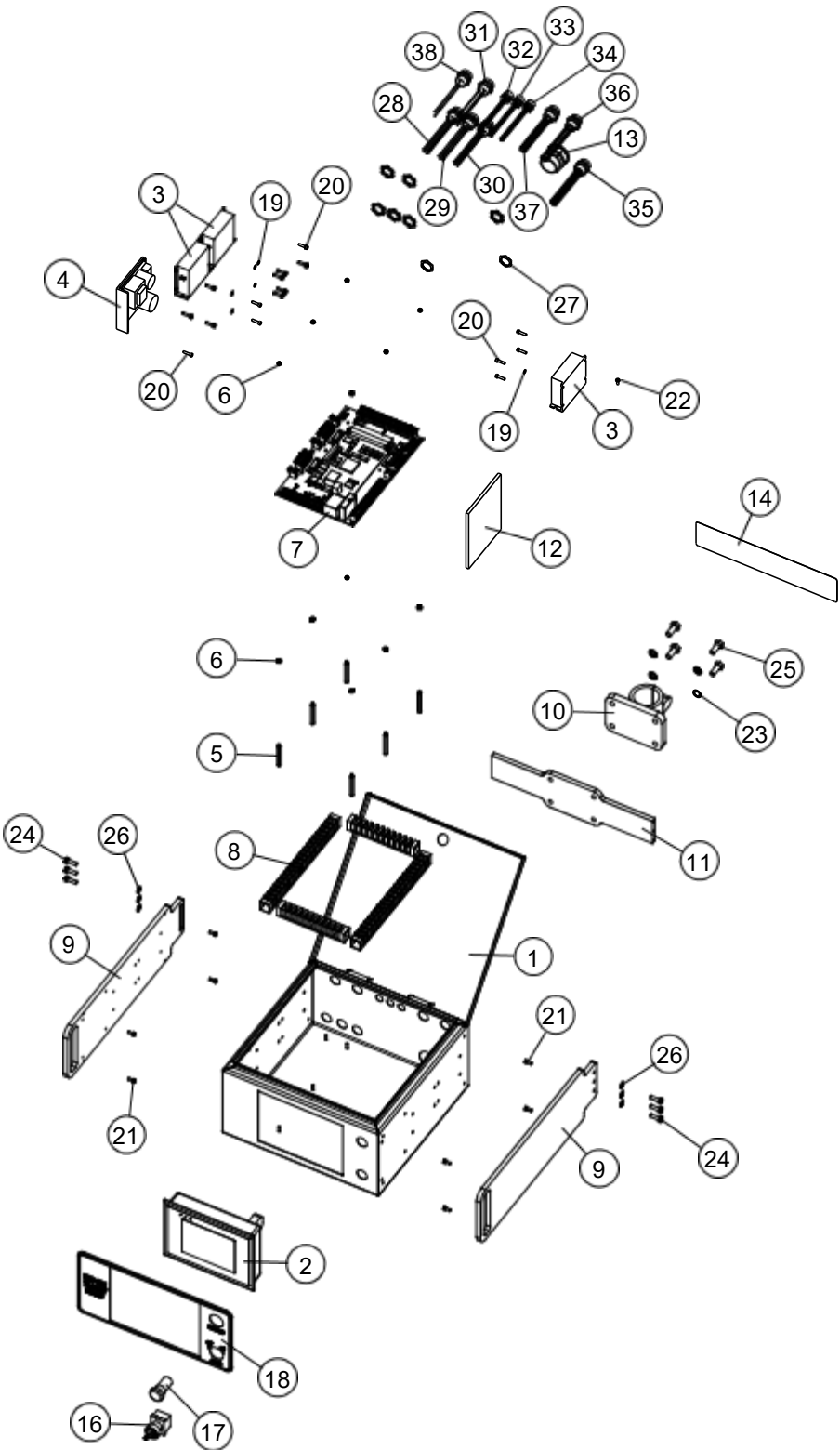

# Circuit Board Assembly

## Parts List

Item No.		Description
1	869303	Circuit Board
2	8 6 8 374	Fuse, 3A
3	869127	Relay, 220VAC, 5VDC Coil
4	869509	Motion Card, Non-Shifting Package Labeler
	869510	Motion Card, Shifting Package Labeler
	869323	
5	869325	Standoff, #2-56 x 3/8-in.
6	869324	Screw, #2-56 x 1/2-in. Long with Washer
7	860546	Screw, #2-56 x 3/16-in. Long with Washer
8	869310	Fuse, 4A MDA
9	868938	Connector, 96 pin, Right Angle
10		Power Supply, 24VDC, 65 Watt

# Circuit Board Assembly Diagram

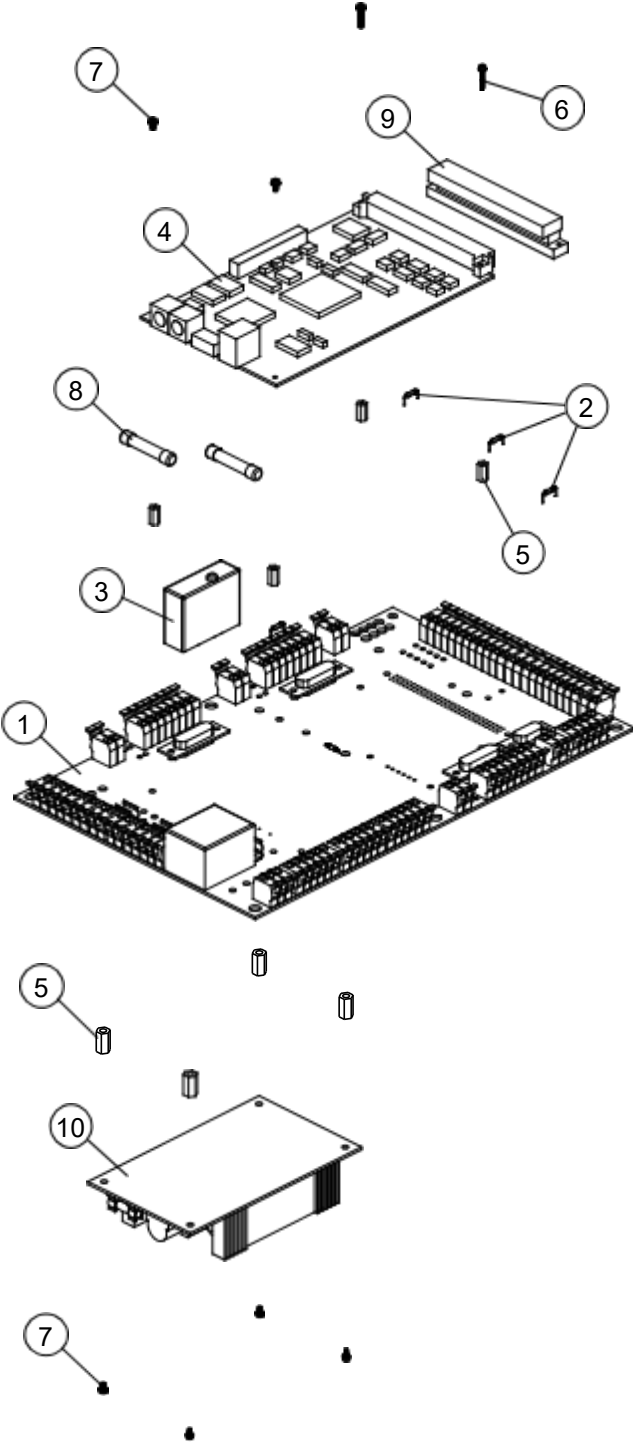

# Cables

## Parts List

Item No.	Chassis Width		Description
1	ALL	890128	Cable, Proximity Sensor
2	ALL		Cable, Label Sensor
3	320-420-520 620-720-820	890123	Cable, Tamp Unit
	320-420	890124	Cable, Tamp Unit
4	520-620	890125	Cable, Blow-On
	720-820	890126	Cable, Blow-On
	ALL	890127	Cable, Blow On
	320-420	869410	
5	520-620	8 9 0118	Junction Block, "B"
6	720-820	8 9 0119	Cable, Motor No. 2, 15-ft.
	320-420	890120	Cable, Motor No. 2, 15-ft.
	520-620	890657	Cable, Motor No. 2, 15-ft.
	720-820	890658	Cable, Motor No. 2, 12-ft.
	320-420	890659	Cable, Motor No. 2, 12-ft.
	520-620	890652	Cable, Motor No. 2, 12-ft.
	720-820	890653	Cable, Motor No. 2, 8-ft.
	ALL	890654	Cable, Motor No. 2, 8-ft.
	ALL	8 9 0117	Cable, Motor No. 2, 8-ft.
	ALL	890656	
	ALL	890651	
7	ALL	869409	Cable, Motor No. 1 and No. 3, 15-ft.
	ALL	869408	Cable, Motor No. 1 and No. 3, 12-ft.
	ALL	869407	Cable, Motor No. 1 and No. 3, 8-ft.
	ALL	890299	
8	320-420-520	890121	Cable, "B" Home Run, 15-ft.
	620-720-820	890122	Cable, "B" Home Run, 12-ft.
	ALL	890133	Cable, "B" Home Run, 8-ft.
	ALL	890133	
9	ALL	890507	Cable Loom (not shown)
10		866842	Cable, Fan
			Cable, Fan
11			Splitter, Euro, 1 Male to 2 Female (optional)
12			Spacer, Junction Block
13			Screw, M4x40 Socket Head

# Cables Diagram

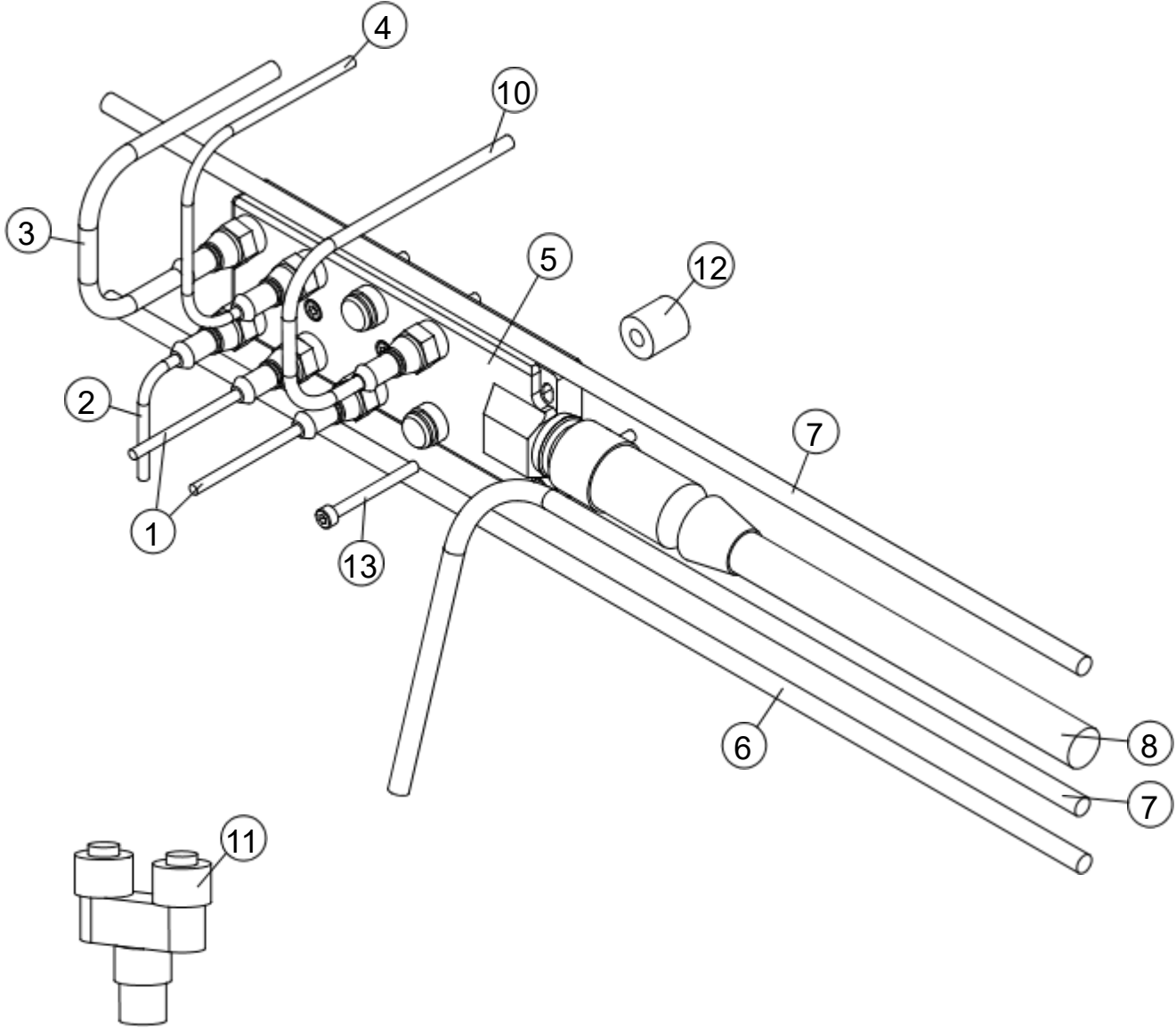

# Servo Motor Control

## Parts List and Diagram

Item No.		Description
1	869318	Servo Drive
2	8 69 317	Servo Drive Mount Plate
3	869337	Cord Grip, PG29
4	869336	Servo Motor Cable
5	869423	Serve 'D' Cable

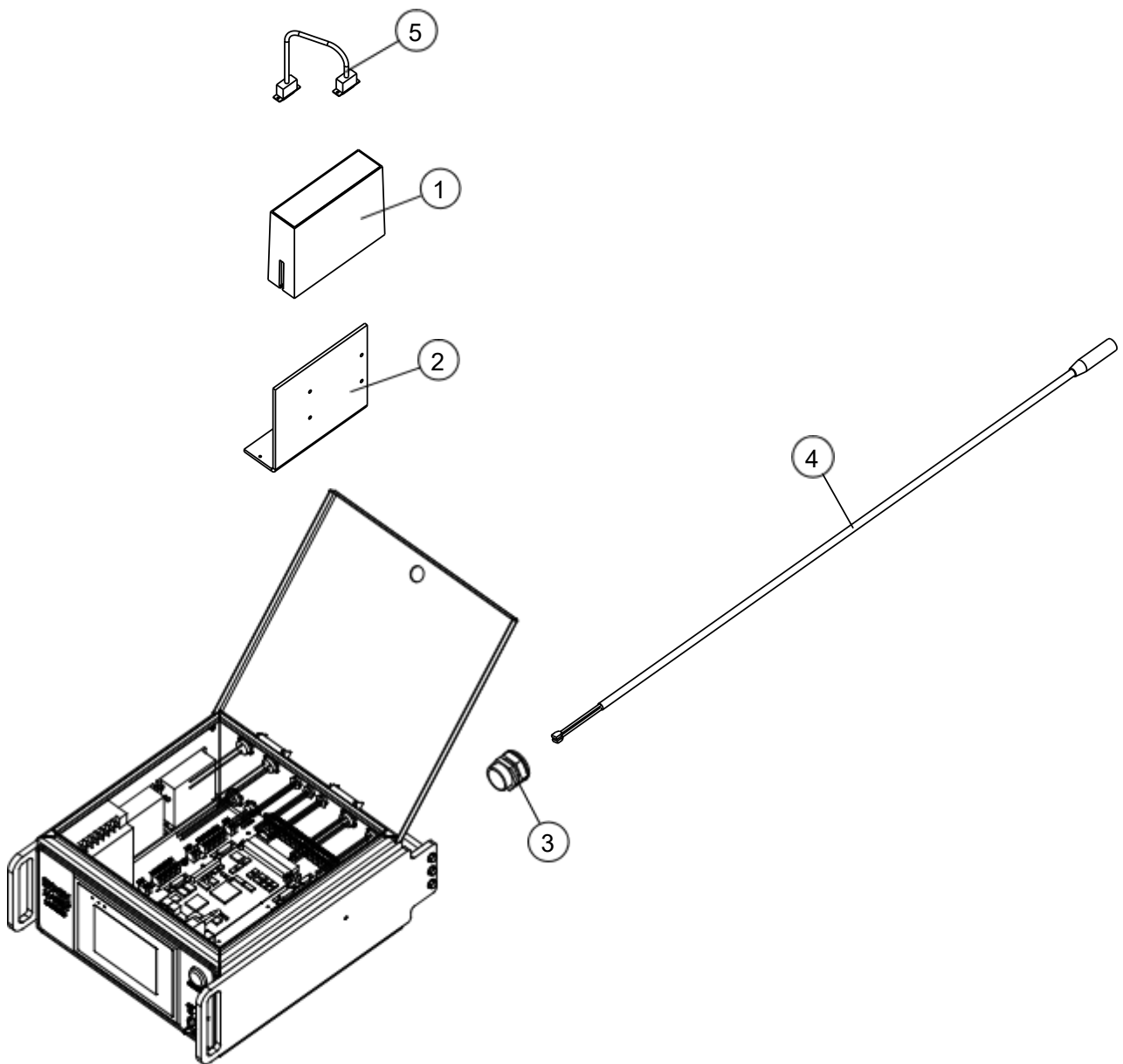

# Clear Label Detector (Option)

## Parts List and Diagram

Item No.		Description
	8150 01	Clear Label Detector (optional), Complete
1	865006	Sensor, Clear Label Scanner
2	890878	Sensor, Bracket Cap
3	890877	Sensor, Bracket Base
4	890258	Thumb Screw
5	866765	Nut, M6x1.0 Hex
6	866826	Bolt, Hex Head M4x20, SS

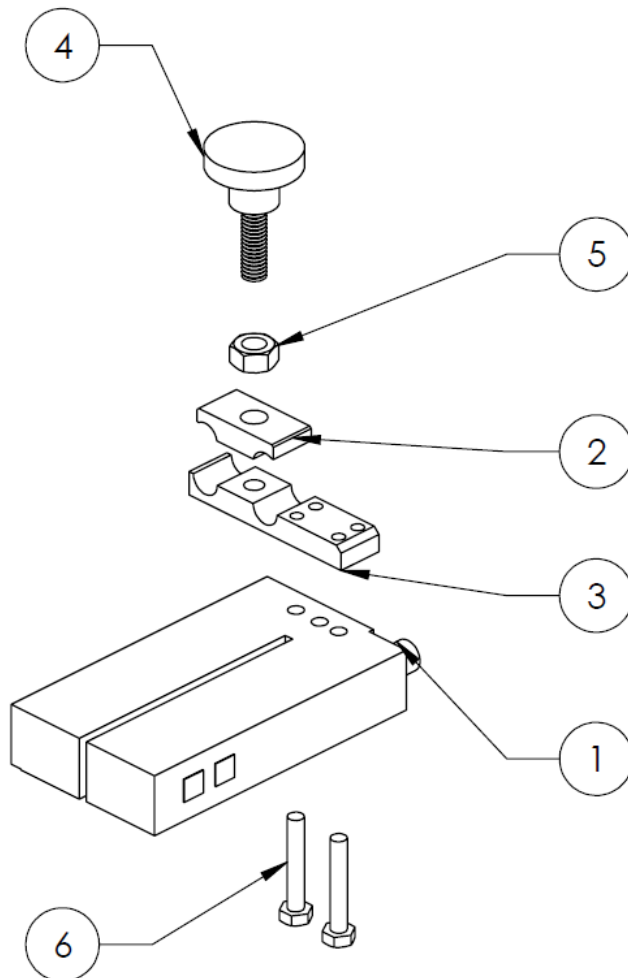

# Clear Label Detector, Leuze (Option)

## Parts List and Diagram

Item No.		Description
	869501	Clear Label Detector (optional), Complete
1	869499	Sensor, Leuze Clear Label
2	869500	Sensor Bracket, Clear Label
3	890878	Sensor Bracket, Leuze Cap
4	890258	Thumb Screw
5	86678 4	Washer, 6mm Split
6	860293	Nut, 6mm Nylon Lock
7	860260	Washer, 5mm Spring Lock, SS
8	866738	Screw, M5x30 Socket Head, SS
9	869503	Cable (not shown)

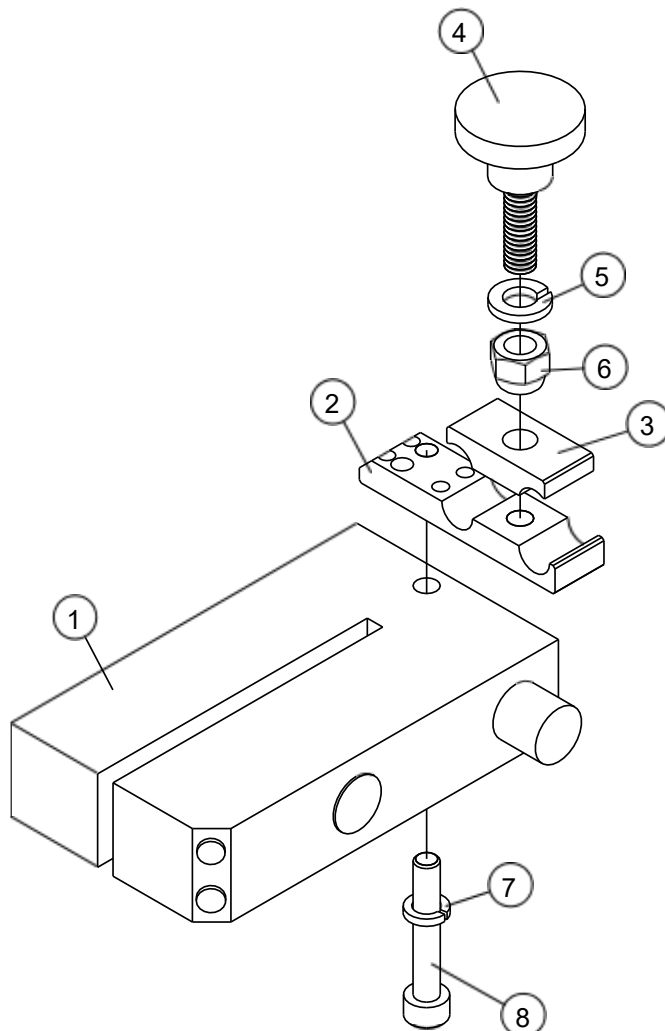

# DATE CODE PRINTER

## Printer Safety

- Read these instructions carefully. Follow all warnings and instructions marked on the printer.
- Always disconnect the printhead cables from the labeler control box and from the labeler chassis before cleaning or servicing the printer.
- Never operate the printhead unless it is installed in the mounting frame supplied. Maintain a maximum of 4mm gap between the printer and the print base.
- Never insert objects into the printer through any openings or gaps as they may touch dangerous voltage points or short circuit parts that could result in fire or electrical shock.
- Ensure the printhead connections cable is fully secured on both ends. Poor connection results in the printhead not being earth grounded properly.
- Use the cable supplied with the printer. The construction is a flex-type cable to accommodate the labeler movement. Be sure that the cables are not walked on or are not rubbing against anything during labeler motion.
- Do not attempt to service this product. Opening or removing guards may expose dangerous voltage, burns, and other risks. Refer all servicing to qualified personnel.
- Do not operate this printer in areas where explosive gases or substances are present.
- Under normal working conditions the printer is very hot. Take precaution when removing the type holder as it can easily burn you. The yellow warning sign on the type holder access door indicates a danger. Grip the door at the side to open. Only hold the type holder by its plastic handle. Place the type holder on a metal or non-combustible surface to cool. Never touch the metal type holder parts unless they have been out of the printer for a minimum of 20 minutes.

### **⚠ CAUTION**

*Hot surfaces. Do not touch.*

*To avoid possible skin burns, disconnect and lockout power. Allow surfaces to cool before servicing or cleaning.*

Disconnect the printhead from electrical and air supplies and refer servicing to qualified personnel under the following conditions:

- If the power cable is damaged or frayed.
- If the printer does not operate normally when the operating instructions are followed.

Adjust only those controls covered by these instructions. Improper adjustment may result in damage.

# Printer Threading and Adjustment

## Magazine Removal

**To remove the foil magazine:** Slide the catch away from the type holder access door and hold in place. Using the two handles withdraw the magazine. If the labeler is cycled while the cassette is off; the labeler will fault with a PRINTER ERROR and the yellow light will come on. Press F1 to clear the fault.

## Foil Threading

1. Fit an empty foil core tube onto the rewind mandrel.
2. Disengage pinch drive from roller.
3. Remove label from new roll of foil.
4. Fit new roll of foil onto take-off mandrel (note the unwind direction as shown on threading diagram).
5. Thread foil around all rollers as shown on the threading diagram. **Note:** The gloss side of the foil should face inward throughout the foil path.
6. Attach foil end to empty core on rewind mandrel, gloss side facing inward.
7. Wind foil a few turns to track and tension it.
8. Engage pinch drive roller.

## Re-Fitting Foil Magazine

Hold the magazine by the two handles, slide it on the locating pins and push to lock in place.

## Fitting Type/Die Holder

**NEVER ASSUME THAT A TYPE HOLDER IS COLD.** Only pick up a type holder by its handle. Ensure the face of the magnetic catch is clean, open the red type holder access door, align the type holder within the two side locators and slide in until the magnet catches on the end plate. Close the door.

### CAUTION

*Hot surfaces. Do not touch.*

*To avoid possible skin burns, disconnect and lockout power. Allow surfaces to cool before servicing or cleaning.*

## Foil Feed Adjusting Screw

This knob adjusts the amount of foil used per print. It is located toward the rear of the printer body adjacent to the air tubing entry points. Turning the knob in reduces the foil index distance. Turning the knob out increases the foil index distance. Be sure to fully tighten the locking nut after adjustment.

# Printer Threading and Adjustment

## Print Orientation

**To rotate the print 90°:** Loosen the printhead handle until it can be rotated. Orient the printhead as needed and retighten printhead handle.

## Printhead Temperature Adjustment

The temperature control is located inside the labeler control cabinet. The control is set to 160°C at the factory. **To adjust the temperature:** The labeler control cabinet door must be opened. The temperature control is located on the right side of cabinet and can be adjusted by turning the circular knob on the face of the control.

## Air Flow Controls

The air flow control is on the valve body mounted on the printer frame. It regulates the speed at which the printhead travels up and down. **Note:** It is very important that the print ram extends completely during each print cycle and that the ram fully returns before the next print cycle begins. Turning the adjustment screws in will slow down the ram speed. For higher speed operation, the flow controls for both the forward and return strokes must be increased. The pressure regulator on the labeler, which controls the printer valve pressure, should be set to 90 p.s.i. (6 Bar).

## Printhead Leveling

The printhead height over the substrate is adjusted using the four 10mm vertical threaded shafts on the printer bracket top corners. **Adjusting the printer height:** First, adjust the height so that the printer does not contact the substrate during cycling. Then adjust each corner of the bracket downward until the printer begins to print on the label surface. Slowly adjust the printer downward until print quality is achieved. If the print is leaving an impression into the label backing paper, the printhead is adjusted too low. If the print is dark on one side and light on the other, then the printhead must be adjusted downward on the side that is light.

# Printer Setup Touchscreen

The printer setup screen allows for control of an optional ink stamp, hot stamp, or thermal transfer printer.

PRINTER ON/OFF :	Turns the printer ON or OFF
PRINTER FAULT ON/OFF :	Turns the printer fault input ON or OFF (if equipped)
HOT STAMP SET TEMPERATURE :	Set point for hot stamp temperature in degree Celsius (150°C)
HOT STAMP ACTUAL TEMPERATURE :	Temperature gauge for hot stamp printer in degree Celsius
PRINTER DWELL :	Time the print signal is held high after each label move (milliseconds). Default from factory: 80mS
PRINTER WAIT :	How long the labeler will wait for the print head to retract before moving the label (milliseconds). Default from factory: 20mS
HOT STAMP HEAT :	Turns hot stamp heater output indicator ON or OFF

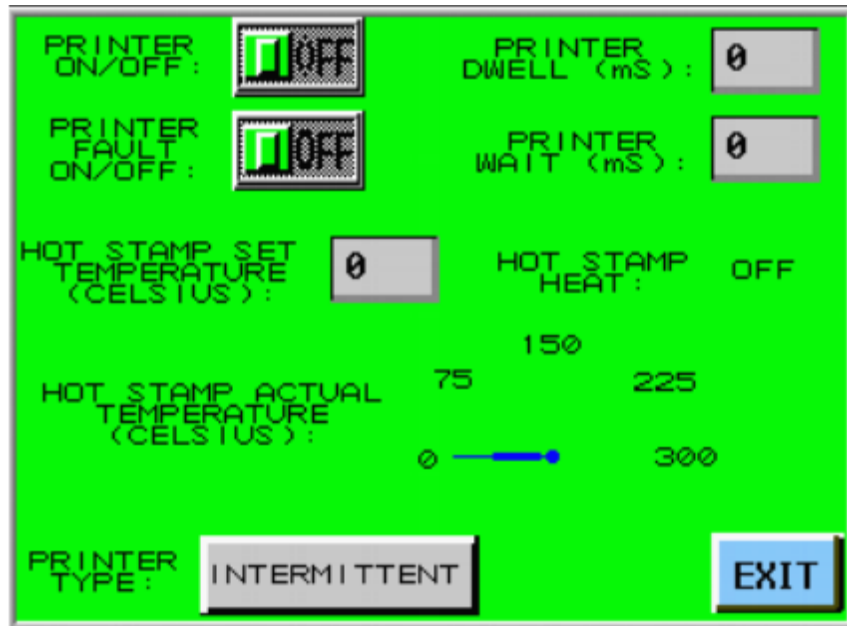

# OEM300 Hot Foil Printer Spare Parts

Part No.		Description
HUB620203	857054	Rewind Hub Assembly
GUI620040	857272	Foil Guide
DRI620049	8570 01	Drive Belt
B R A620 051	857273	Brake Strap
S PI620147	857088	Hub Spindle
B E A 52150 5	857202	Clutch Bearing
D R I620149	857203	Drive Boss
HEA501506	857003	OEM300 Cartridge Heater
THE500502	857123	Thermistor Probe
SWI395011	8 57 274	Safety Microswitch
A L A395018	857005	OEM300 End of Foil Optical Sensor
CPC290500	857275	Plug-In Printer Control Card
SEA620209	857006	OEM300 Seal Kit
S P R 62 0 217	857000	OEM300 Printer Spring Kit
	8 6 6961	Temperature Controller
	866962	Temperature Sensor (RTD)

# OEM300 Cable Schematic

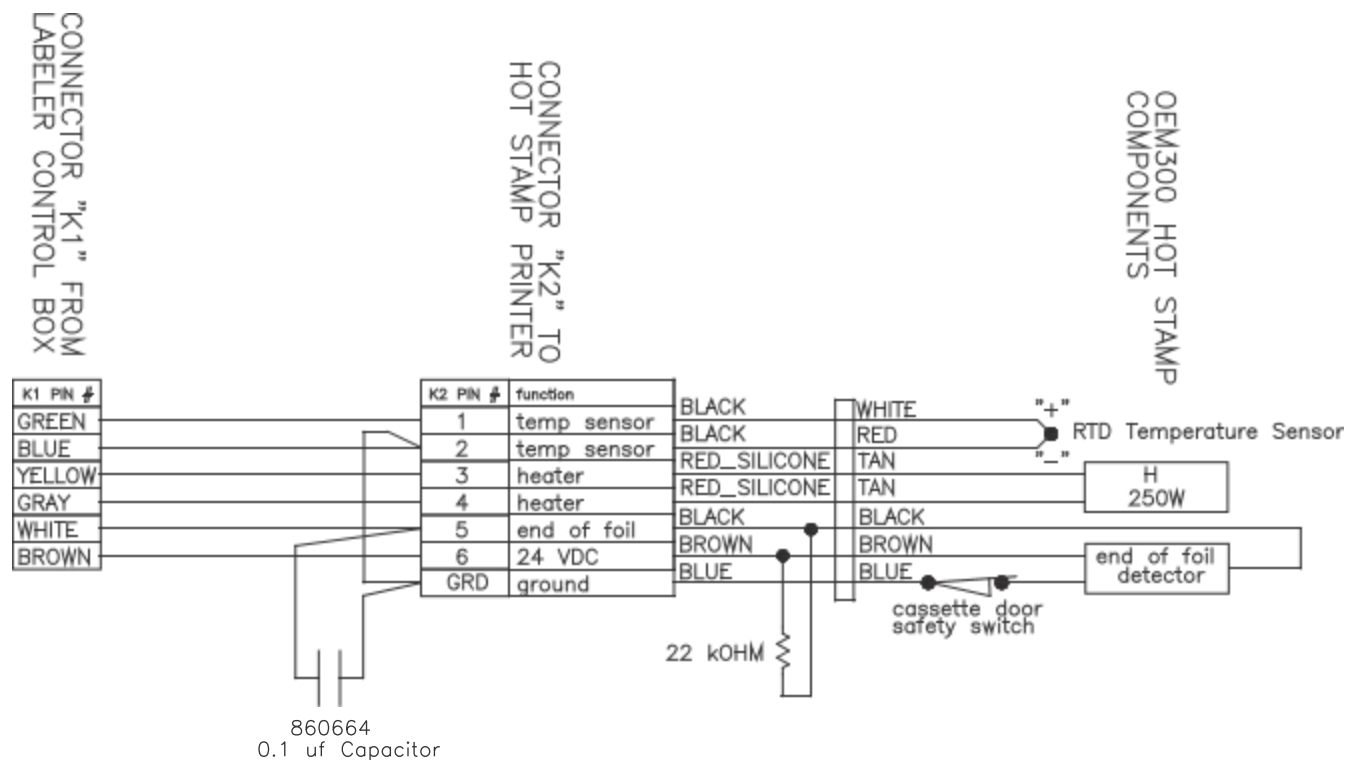

# OEM300 Hot Foil Printer

## Parts List

Item No.	Part No.		Description
1	COV620034	857133	Cover
2	SWI395010	857004	Microswitch
3	SUP620 031	857266	Support, Microswitch
4	HEA501506	857003	Cartridge Heater
5	THE500503	857130	Thermistor Probe
6	C A P620195	857249	Bottom Cap Assembly
7	H E A120 013	857036	Heater Block
8	S I D120 014	857018	Slide Locator
9	O - R 5120 3 0	857267	O-Ring
10	S E A 5120 38	857139	Rod Seal
11	B E A 522016	857008	Bearing
12	S E A 5120 36	857168	Piston Seal
13	O R 5120 0 5	8 5 7 115	O-Ring
14	D A M12 0 074	8 5 7 114	Cylinder Damper
15	PIS620020	857037	Piston
16	BEA620040	857007	Bearing
17	FOR620208	8 5 7 011	Fork End Roller
18	B E A 5210 01	857081	Needle Bearing
19	B E A 520 018	857085	Needle Bearing
20	SPR530033	857013	Torsion Spring
21	CON398108	857033	Plug
22	PUL620033	857201	Timing Pulley
23	PUL620030	857156	Timing Pulley
24	C A M620025	857268	Cam
25	B E L 522512	857019	Timing Belt
26	SPI620024	857101	Spindle
27	SPI620029	857079	Drive Spindle
28	PLU399415	857269	Wired Plug
29	K E E120 0 3 0	8 5 7 017	Keeper Plate
30	PL A620026	857025	Mounting Plate
31	INS129514	857270	Insulator Plate, 10mm Thick
32	PAC190 0 28	857028	Data Box Packing

# OEM300 Hot Foil Printer Diagram

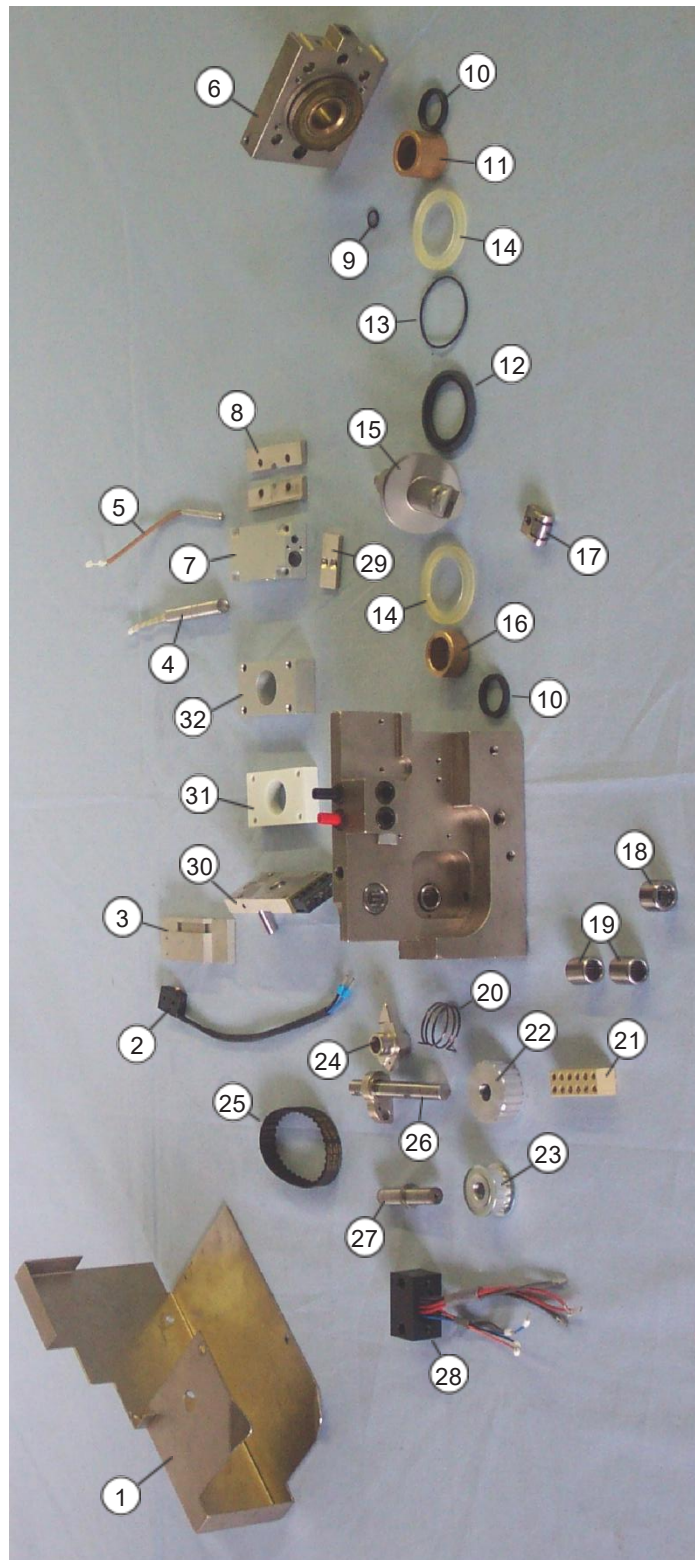

## OEM300 Hot Foil Printer (continued)

### Parts List

Item No.	Part No.		Description
33	T H U620127	857015	Release Button
34	SPI620003	857054	Hub Spindle
35	ANC190006	857127	Anchor
36	SPI620005	857069	Roller Spindle
37	BUS190008	857064	Bushing
38	DOO620203	8 57170	Door Assembly
39	DRI620204	857009	Drive Roller Assembly
40	HUB620203	857053	Rewind Hub Assembly
41	HUB620201	857055	Take-Off Hub Assembly
42	LO C620129	857196	Locking Plate
43	SPI620007	857078	Drive Roller Spindle
44	ROL620 018	857051	Idler Roller
45	DRI620048	857271	Drive Belt, 180
46	ROL620009	857063	Roller
47	GUI620006	857129	Foil Guide
48	BR A620038	857002	Brake Strap
49	B U S190 012	857047	Bushing
50	SPA120042	857 108	Spacer
51	SPR 530 018	857146	Spring
52	DAN620008	857045	Dancing Bar
53	AR M620 01	857049	Dancing Arm
54	YO K620 012	857191	Yoke
55	S P I620 015	857031	Pinch Roller Spindle
56	PIN620205	857030	Pinch Roller Assembly
57	WAS120035	857126	Washer
58		857125	Screw, M3x6 Button Head
59		857089	Support
60		857070	Handle
61		8 5 7 111	Spindle
	SUP1290024		
	HAN530502		
	S PI620 013		

# OEM300 Hot Foil Printer (continued) Diagram

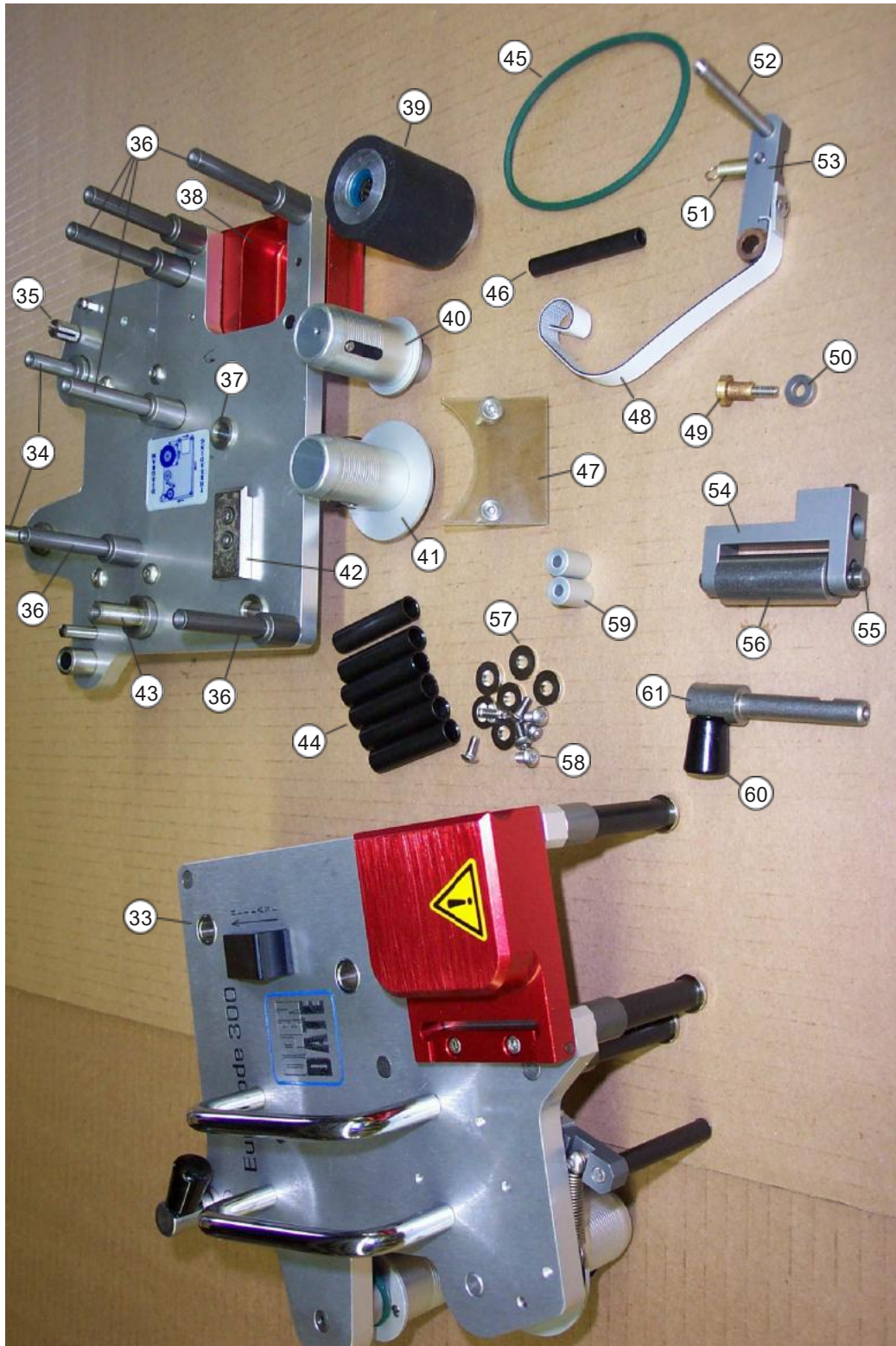

# Printer Bracket Assembly

## Parts List

Item No.		Description
1	890 410	Printer Post Block, Lower
2	890 413	Printer Horizontal Rack Shaft
3	810108	Bolt, M8x30 Hex Head
4	866775	Washer, 8mm Flat
5	890 412	Printer Vertical Rack Post
6	866981	Hot Stamp Vertical Screw
7	866767	Nut, M10 Hex
8	866776	Washer, 10mm Flat
9	810112	Bolt, M10x40 Hex Head
10	890 416	Main Printer Mount Block
11	890403	Tapped Insert for Drive Head
12	810107	Bolt, M8x20 Hex Head
13	890 021	Axle, Drive Head Roller, 150mm
	890533	Axle, Drive Head Roller, 200mm
	866801	
	866048	
	890020	
14	890 019	Retaining Ring, External, 12mm
15	890729	Ball Bearing
16	890452	Hub for 2-in. Idler Roller
17	890293	Idler Roller, 1-7/8-in. OD
18	890420	O Ring, Silicone
19	810103	Printer Mount Adaptor
20	866582	Scale Bar
21	890 414	Printer Scale Mount
22	866827	Bolt, M5x20 Hex Head
23	890402	Valve Assembly, Single
24	890 013	Printer Valve Bracket
25	890003	Screw, M4x25 Socket Head
26	890 017	Printer Mount Plate
27	866566	Unwind Mount Plate
28	866253	Tapped Insert
29	866247	Shaft Extension
30	890434	Fitting, Flow Control, 1/8 x 6
31	810105	T-Fitting, 8mm
32		Silencer, 1/8
33		Cam Lock, Chassis Tube
34		Bolt, M6x25 Hex Head

# Printer Bracket Assembly Diagram

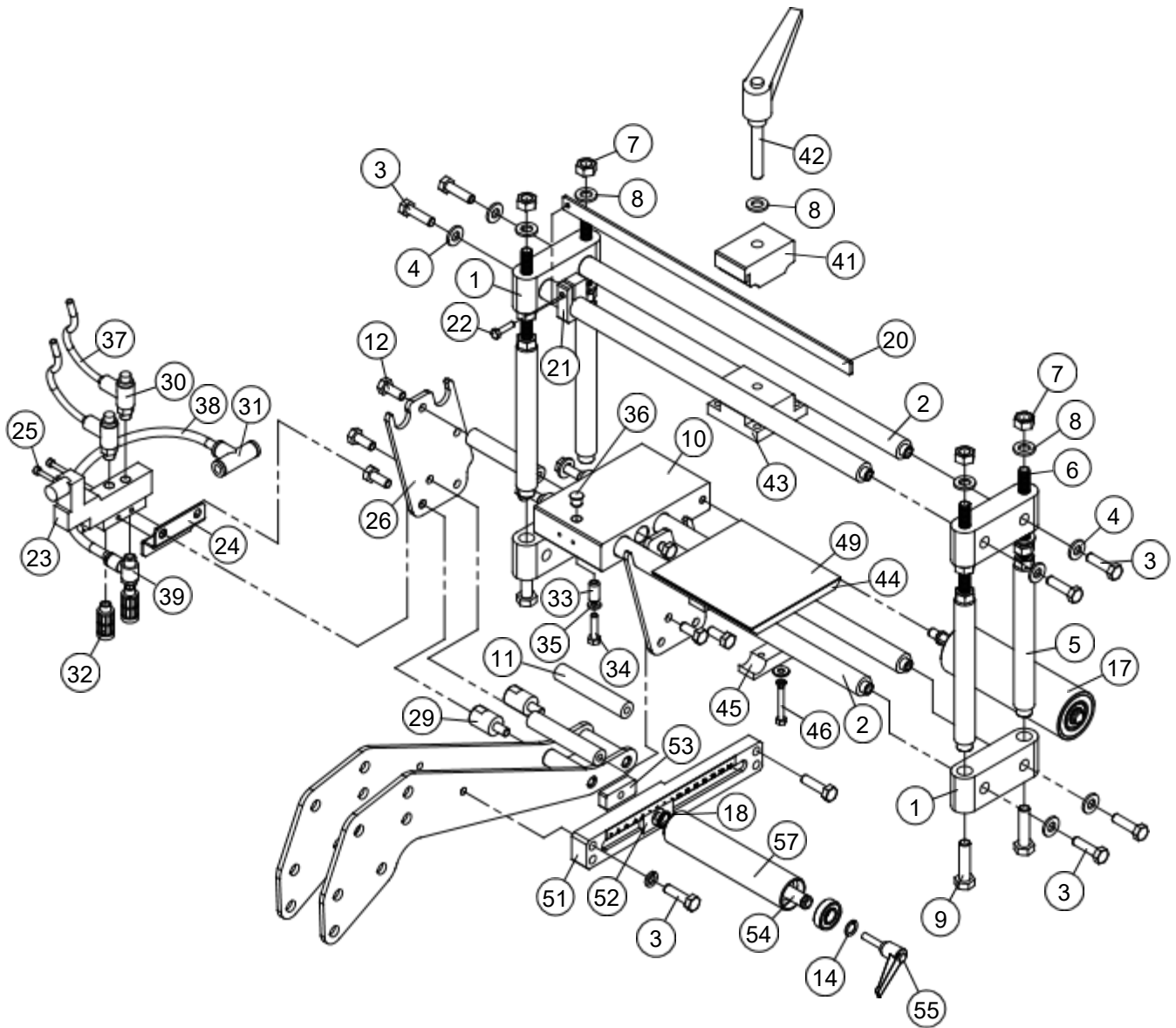

# Printer Bracket Assembly (continued)

## Parts List

Item No.		Description
35	86678 4	Washer, 6mm Split
36	E103	Plug, 3/8
37	866575	Tubing, 6 Pun
38	866576	Tubing, 8 Pun
39	866251	Fitting, 90°, 1/8x6
40	860665	Printer Mount Adaptor
41	890913	Printer Mount Cap
42	866601	Handle
43	8 9 0 417	Printer Mount Adaptor
44	8 9 0 874	HS Contact Pad Plate
45	890 876	HS Platten Support
46	860296	Bolt, M5x35 Hex Head
47	866791	Washer, 5mm Large OD
48	860260	Washer, 5mm Split
49	890875	HS Contact Pad
50	860290	Washer, 8mm Lock
51	890948	Printer Adjustment Bar
52	890929	Roller Lock, Front
53	890930	Roller Lock, Back
54	890954	Shaft, Printer Adjustment
55	810 057	Handle
56	890432	Scale Rule
57	890080	Roller, Small OD, 150mm Long
	890686	Roller, Small OD, 200mm Long

# Printer Bracket Assembly (continued) Diagram

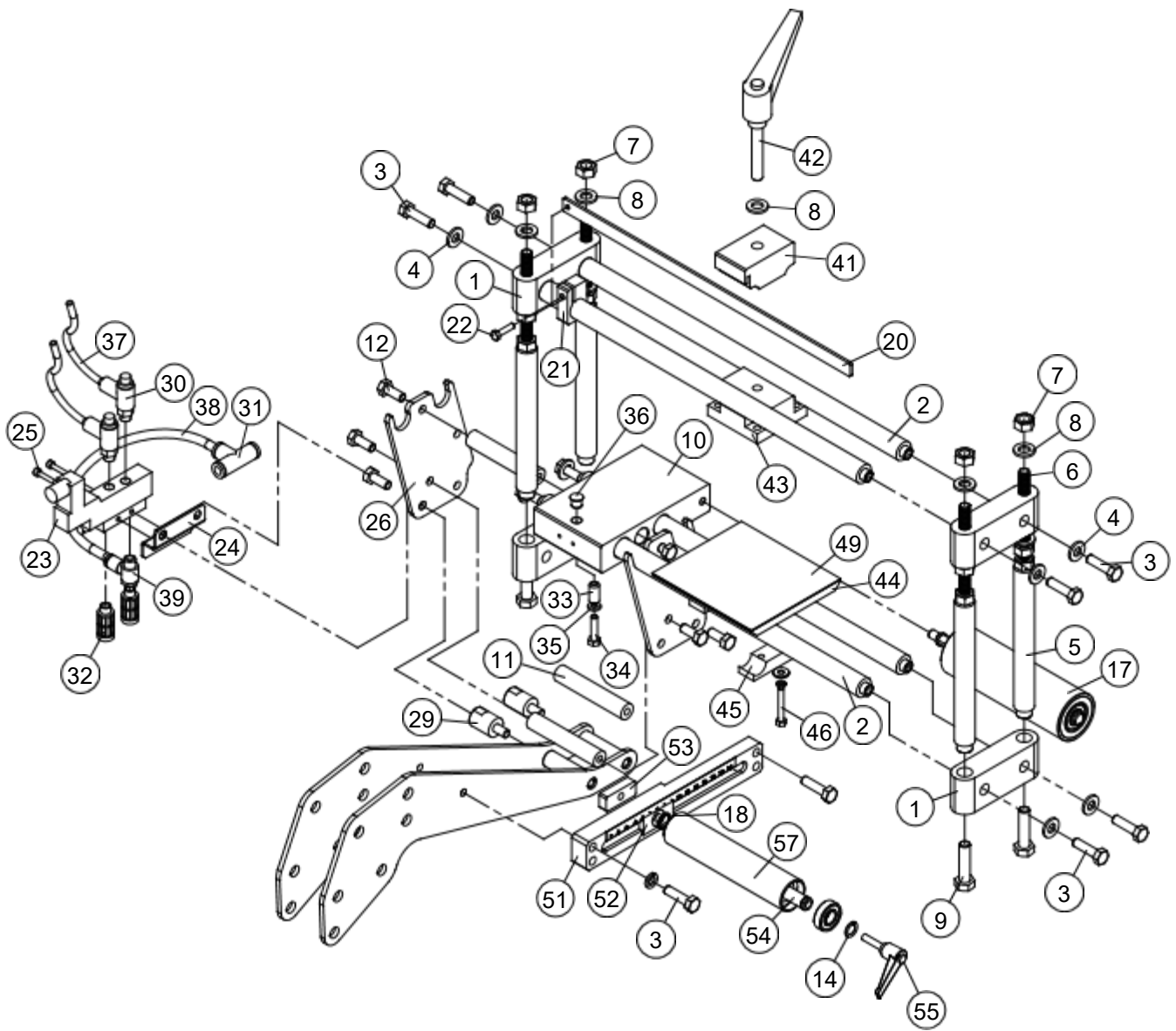

## Troubleshooting

<b>Problem</b>	<b>Indicators</b>	<b>Remedy</b>
Printer does not cycle and LED on printer valve DIN connector is "OFF" and 24VDC relay LED is dim or "OFF"	Printer is turned off	Turn printer on
	Relay has failed or is not connected	Check relay connections first then replace relay
	Loose connection on relay input to stepper drive #1	Check connections
Printer does not cycle and LED on printer valve DIN connector is "OFF" and 24VDC relay LED is "ON"	Loose connection between relay output and printer valve connector	Check connections
Printer does not cycle and LED on printer valve DIN connector is "ON"	Line pressure is low	Restore system pressure
	Valve or valve coil has failed	Replace valve
Printer fault indicator comes "ON"	Ribbon is empty	Replace ribbon
	End of foil photoeye has failed	Replace photoeye
	Cassette is loose or type holder door is open	Replace cassette and close type holder door
	Switches on the cassette and type holder door have failed	Replace failed switches
Print quality is poor	Insufficient foil pull or air pressure	Restore line pressure and flow
	Printer not level with base	Readjust printer frame
	Temperature too high or low	Adjust temperature by using controller inside the labeler control cabinet
	Dirty, worn, or damaged dies or type	Replace type
	Damaged or out of position print base rubber	Adjust bottom base rubber block to a new position
	Printing foil not compatible with substrate	Contact foil manufacturer
	Label moving before printhead is clear	Increase print wait time
	Print dwell is too low	Increase print dwell time

# TROUBLESHOOTING

## Sensing and Dispense

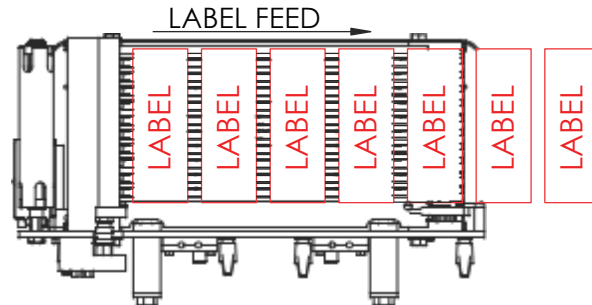

Problem	Indications	Remedy
Labels run out quickly without stopping	Labels misthread	Confirm labels are running in forked gap of sensor and not threaded around blow-on tube
	Label sensor not set for current material	Adjust sensor sensitivity per instructions
	Label sensor bad	After setting sensitivity, confirm RED LED is ON in the label gap and OFF over label stock
	Label speed too high	Lower label speed (or have maintenance increase acceleration rate in Maintenance screen)
	Label peel over parameter (#3) is set too low	Increase peel parameter

# Sensing and Dispense

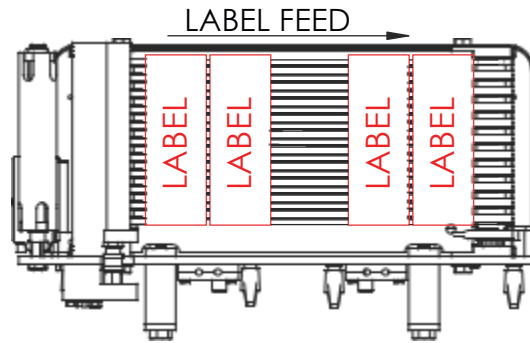

Problem	Indications	Remedy
Labels dispense two at a time, consistently in pairs	Label peel over parameter (#3) is set too high	Lower peel parameter and/or move sensor position as needed. This parameter should always be less than the label length

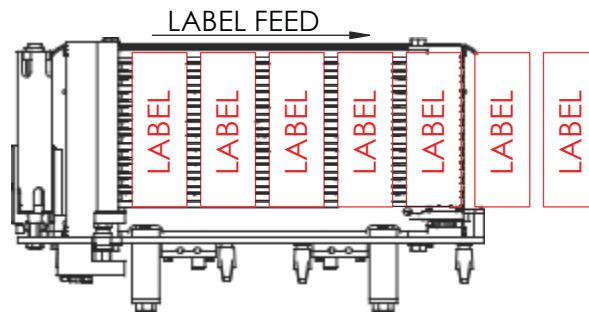

Problem	Indications	Remedy
Labels dispense two at a time, occasionally	Label sensor sensitivity not set	Adjust sensor sensitivity per instructions, page 3.16

# Sensing and Dispense

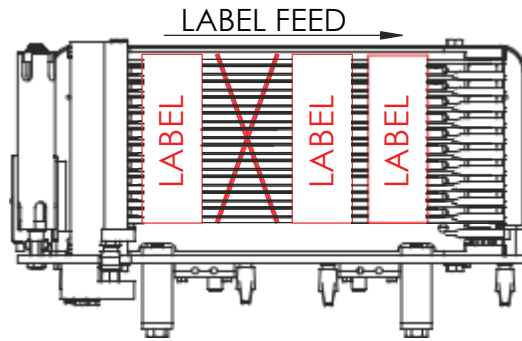

Problem	Indications	Remedy
Labels missing	Empty package detection sensor not set or adjusted	Check sensor height and adjust sensor (screw terminal) as needed to confirm sensor operation over product
	Label sticking to blow-on tube	Adjust blow tube direction and/or flow control and/or peel over parameter #3; blow on tube should be adjusted at 12 o'clock and set to peel edge
		Check for missing labels on label rolls Make sure knurled tension roller is locked down. See page 3.1
Label backing paper tearing		Make sure label reel is tightened against label roll to assure proper dancer operation
	Check peel bar edge for nicks or cuts	Replace peel bar if necessary
	Check label backing paper for heavy die cut marks	Replace label roll if cut marks are easily visible
		Make sure knurled tension roller is locked down. See page 3.1 Make sure label brake arms are in position. See page 3.1

# Transport Across Web

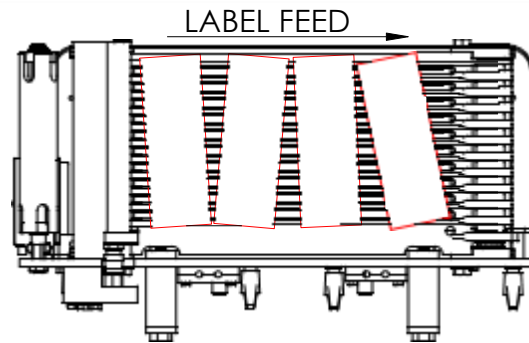

Problem	Indications	Remedy
All labels misaligned after transport, before tamping	Vacuum fans blocked or failed	Check for clear operation of all fans
	Blow-on tube directed out toward transporter and/or adjusted too high	Rotate blow-on tube where hole faces directly down toward transports or slightly back toward peel bar
		Adjust flow on blow-on valve on the end of the labeler by the air prep unit
	Peel over setting	Make sure at least 1mm of label edge is visible on peel bar, and not more than 3mm
	Label material stuck to tamp blades or transport belts	Clean and remove any material
	Labeler brake adjusted loosely	Increase brake tension on labeler
	Label material die cut into backing paper	Check liner for cut marks. If present, talk to label supplier about correcting; use 4mil or thicker labels to improve operation. Less than 4mil increases risk of die cut alignment problems
	Green transport belts loose	Tighten belts using adjustment bolts
		If labels are round or non-rectangular, be sure labels and photo sensor are positioned consistently and reading the same position on the label

# Transport Across Web

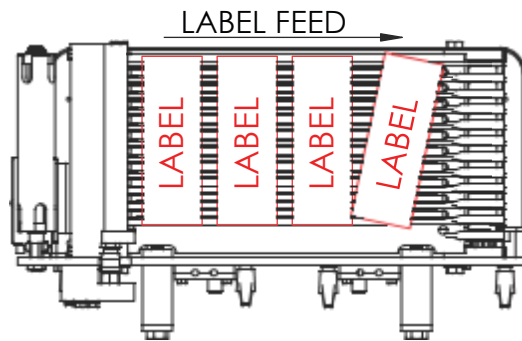

Problem	Indications	Remedy
First label out misaligned after transport, before tamping	Tamp retract time too short, resulting in first label dispensed making contact with the retracting tamp blades	Increase tamp wait time (parameter #7)
		Speed up tamp cylinder retract by opening flow control knob
		Parameter #7, tamp wait time, should always be set at least 20 mS higher than parameter #6, tamp time

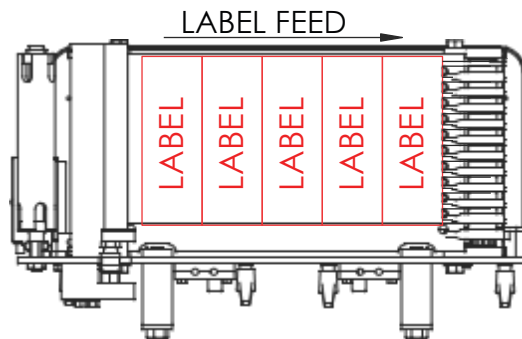

Problem	Indications	Remedy
Labels aligned but coming up short in position	Transporter stalling or belts slipping	Decrease transporter motor speed
		Tighten transporter belts

## Placement in Machine Direction

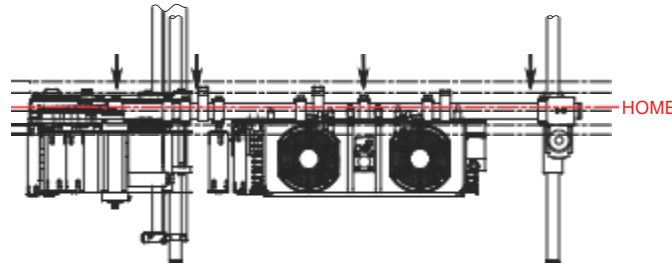

Problem	Indications	Remedy
Labeler stopping position varies	Longitudinal speed set too high	Reduce parameter #10
	Home position sensor defective	Replace sensor
	Home sensor slug adjusted too low	Raise sensor target panhead bolt height
	Label reels and/or guide collars have been moved	Reset inside reel and/or guide collar position

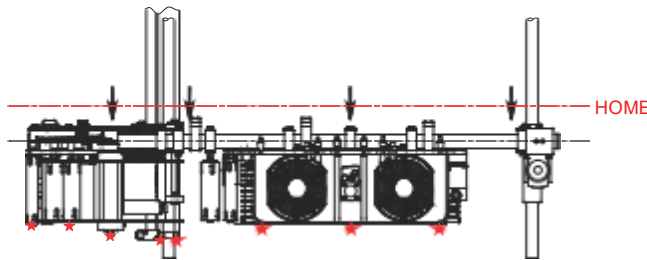

Problem	Indications	Remedy
Labeler runs past the home sensor	Longitudinal speed set too high	Reduce parameter #10
	Offset parameter #13 set too low	Move home position mount to allow parameter to be increased, minimum setting 20mm
	Home position sensor defective	Replace sensor
Labeler hits End of Travel Sensor	EOT (End of Travel) sensor slugs are adjusted too close to labeler operating region	Move sensor target panhead bolt minimum 2-in. outside of operating region
Labeler shifting motor stalls	Longitudinal speed set too high	Reduce parameter #10
		Decrease longitudinal acceleration rate in Maintenance screen
	Stepper motor defective	Replace stepper motor

# Tamp

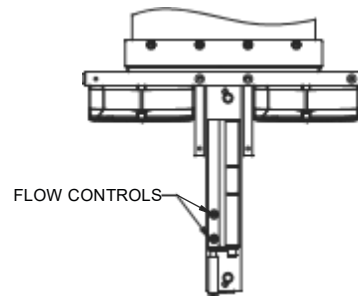
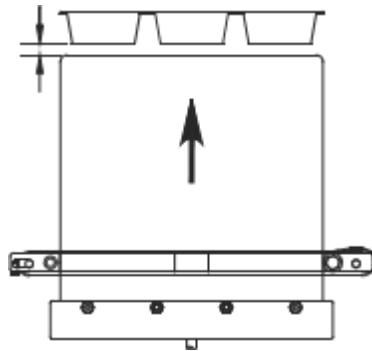

Problem	Indications	Remedy
Label Tamp not reaching surface	Not enough air pressure	Check regulator to confirm pressure is at 90 p.s.i. (6 Bar)
	Tamp time is not set high enough (parameter #6)	Increase tamp time
	Tamp cylinder flow control is not adjusted	Open flow control adjustment as shown
	Cylinder worn or shaft bent	Replace or repair cylinder

**Note:** For higher speed applications, the flow control adjustment should be left completely open and the tamp setting should be adjusted primarily using tamp time.

# Tamp

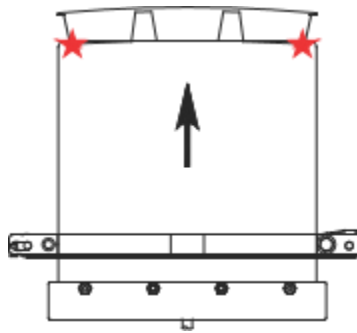

Problem	Indications	Remedy
Label tamp not reaching surface	Too much air pressure	Check regulator to confirm pressure is at 90 p.s.i. (6 Bar)
	Tamp time is set too high for flow control adjustment	Decrease tamp time by 5mS increments or close off flow control adjustments one half turn until desired tamp is reached
Label tamp varying throughout the day	Supply air pressure varying and/or not high enough pressure source	Change or improve the air source to provide a minimum of 90 p.s.i. (6 Bar) to the labeler regulator
	Water in the tamp valve or regulator	Open drain on regulator and clear the water present
	Tamp valve or cylinder worn	Replace components

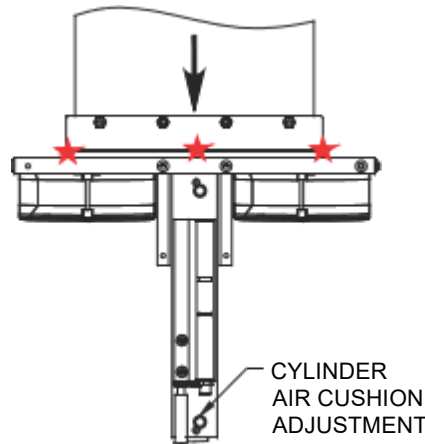

Problem	Indications	Remedy
Label tamp banging on return stroke	Cylinder air cushion is out of adjustment	Tighten air cushion until desired return stroke is achieved. Do not tighten cushion too much, or tamp blades will retract too slowly and impede the label dispense

## Labeler Speed

Labeler speed and acceleration is a function of motor speeds, die configuration, and tamp times. The labeler speed is entered in mm/sec and the acceleration rate is entered in mm/sec<sup>2</sup>. There are three motor options available; standard-torque, high-torque, and super-torque. The motor speeds listed below are average speeds for these motors. Some factors, such as temperature and label size, may reduce the actual speed that the labeler can achieve. In general, the labeler speeds should be set as low as possible while still maintaining packaging machine line speed.

<b>Standard-Torque (Black)</b>		
<b>Motor</b>	<b>Parameter</b>	<b>Max.</b>
Label Speed	8	400
Transporter Speed	9	600
Longitudinal Speed	10	400
Label Acceleration Rate	Maintenance	15000
Shift Acceleration Rate	Maintenance	2000

<b>High-Torque (Burgundy)</b>		
<b>Motor</b>	<b>Parameter</b>	<b>Max.</b>
Label Speed	8	500
Transporter Speed	9	700
Longitudinal Speed	10	500
Label Acceleration Rate	Maintenance	20000
Shift Acceleration Rate	Maintenance	3000

<b>Super-Torque (White)</b>		
<b>Motor</b>	<b>Parameter</b>	<b>Max.</b>
Label Speed	8	600
Transporter Speed	9	700
Longitudinal Speed	10	600
Label Acceleration Rate	Maintenance	25000
Shift Acceleration Rate	Maintenance	4000

## Blow-On and Display

Location	Problem	Indications	Remedy
Blow-On	Blow-on does not activate with valve and relay LED (on PWB) indicators "ON"	Loss of air pressure	Restore line pressure
		Pressure regulator not set or faulty	Set or repair pressure regulator to 90 p.s.i. (6 Bar)
		Flow control out of adjustment	Open flow controls to obtain proper operation
		Valve coil damaged	Replace coil
		Valve(s) damaged	Replace valves
		FILM/PACK switch on PWB set to FILM	Set switch to PACK
	Blow-on does not activate with valve LED indicator OFF and relay LED (on PWB) indicators "ON"	Relay damaged or not seated properly	Replace or reinstall relay
		Connection between relay output and valve faulty	Check connections
		5 amp fuse on PWB board blown	Replace fuse and check isolation
	Blow-on does not activate relay LED indicators (on PWB) "OFF"	Drive I/O not reaching relay input	Check connections, reseal/replace PWB ribbon cables
Drive I/O damaged		Replace drive	
Display	Labeler does not display anything on screen	220 VAC disconnected	Check 220 VAC input
		Main control power fuse blown	Replace fuse
		24 VDC power supply fuse blown	
		24 VDC power supply failed	Replace power supply
		24 VDC power supply connection loose	Check connections on power supply pins and PWB
		24 VDC time delay relay failed	Replace time delay relay
		Touchscreen failed	Replace touchscreen

## Common Fault

Location	Problem	Indications	Remedy
Common Fault	Labeler displays: "Communications Error Drive #1, 2, 3"		
	With both stepper drives and 75 VDC power supply GREEN LEDs "ON"	Drive DIP Switches not set properly	See page 5.1 for proper switch settings on drive # displayed on screen
		RS232 cable between drives and computer is disconnected	Check cables, reseal RS232 cable connectors/ verify cable pin-out to schematic on page 5.2, replace cable
		Bad communication ports on drive or touchscreen	Replace Drive # shown on screen. If Drive #1 is displayed, touchscreen port may also be bad.
			Check output of the power supply. Voltage 55VDC minimum, 62VDC average, 75VDC maximum. Replace power supply.
	With stepper drives and 75VDC power supply GREEN LEDs "OFF" and Touchscreen "ON"	75VDC power supply failed	Cycle power to reset. Check 2A fuse on Power Supply. Individually disconnect power cables to drives to eliminate shorted drive. Replace power supply.
	With stepper drive GREEN LEDs "OFF" and power supply GREEN LED "ON"	Power supply has experienced a high voltage fault	Check for over-voltage condition. Replace drive if 75VDC power is confirmed. Install isolation transformer, if AC peaks above 264VDC
With drive RED LED "ON"	Stepper drive has faulted	Cycle power to clear fault/replace drive	

## Drives, Faults, and Sensors

Location	Problem	Indications	Remedy
Drive Power	Drive power GREEN LED is not "ON"	The drive is not receiving adequate DC voltage	Verify the VDC+ and VDC- connections. Voltage 55VDC minimum, 62VDC average, 75VDC maximum.
		Drive power cable screw terminals are loose	Tighten screws
Fault General	Labeler displays: "Stepper Motor has stalled or label feed has been disrupted" and YELLOW fault light is "ON"	A stepper motor has stalled	Clean any residual glue from peel bar and brakes. Lower speed and/or acceleration of motors.
		Labeler roll backing paper has torn	Rethread labeler and check brake and photo-eye for obstruction of backing paper
		Labeler NIP roller open	Close NIP roller
		Label roll is empty	Refill labeler
Fault End of Travel	Labeler displays "C.W. End of Travel Limit has been Hit" or "C.C.W. End of Travel Limit has been Hit"	The longitudinal shift has tripped on a clockwise (C.W.) or counterclockwise (C.C.W.) limit during a normal move cycle	Readjust the end of travel sensor positions or the move parameters or both. Also verify that no debris has built up on sensors.
Fault Drive	The drive fault RED LED is "ON"	The drive is overheating	Verify that drive heat sink does not exceed 55°C
		Drive is damaged	Replace the drive
Home/EOT Sensors	End of Travel and HOME proximity switches do not function with LEDs (RED) "OFF"	Proximity sensors do not have 24VDC or ground	Check connections
		Proximity sensors damaged	Replace proximity sensors
		Proximity sensor and contact distance too large	Check labeler mounting for planarity

## Sensors, Labels, and Motor

Location	Problem	Indications	Remedy
Home/EOT sensors	End of Travel and HOME proximity switches do not function with LEDs (RED) "ON"	Proximity sensors damaged	Verify sensors signal operation voltage (+5V open/0.8V closed) at PWB
		Drive #3 inputs damaged	Swap Drives #2 and #3 in cabinet and re-test
Labels stopping	Label gaps missed or runaway labels	Label sensor out of adjustment	Set label sensor, see page 3.16
		Label speed set too high	Decrease label speed parameter or increase acceleration parameter (call Ultravac Services Inc.)
Motor torque	There is little or no holding torque; the power LED is "ON" and the motor fault RED LED is "OFF"	Current select AMPS DIP is set improperly	Confirm proper drive switch settings, page 5.1
		Motor internally shorted	Check motor impedance and replace if necessary
		Low AC line voltage	Verify incoming Line Voltage is minimum 208VAC and maximum of 264VAC
		Drive failure	Replace drive
Motor operation	Motor does not move with Drive Power LED (green) "ON"	Motor circuit or motor has short or open circuit	Disconnect power from the labeler and motor wiring from the drive (A+, A-, B+, B-). Check continuity across A phase and B phase (maximum of 1.0 ohms for large motor and 5.0 ohms for small motor). Check for isolation between phases and to ground.
	Motor jerking	Bad motor windings	Verify A and B loop as described above. Replace motor if necessary.

## Power and Tamp

Location	Problem	Indications	Remedy
Power	Stepper drives power GREEN LEDs are "OFF" and the 75VDC power supply GREEN LED is "OFF"	No 220VAC power	Verify AC power, 208VAC minimum and 264VAC maximum
		Power supply has had a thermal shut down	Measure temperature at heat sink (60°C maximum)
		75VDC power supply damaged	Replace power supply
	Stepper drives power GREEN LEDs are "OFF" and the 75VDC power supply GREEN LED is "ON"	Short or open circuit in drive cabling or motor	Check drive cabling and then cycle AC power
		Power supply experienced an over voltage condition	Cycle AC power
	Touchscreen comes on, but 24VDC output does not	24VDC time delay relay failed	Replace time delay relay
Tamp	Tamp cylinder does not activate with valve and relay LED (on PWB) indicators "ON"	Loss of air pressure	Restore line pressure
		Pressure regulator not set or faulty	Set or repair pressure regulator to 90 p.s.i. (6 Bar)
		Flow controls out of adjustment	Open flow controls to obtain proper operation
		Valve coil damaged	Replace coil
		Valve(s) damaged	Replace valve(s)
		Tamp time set too low	Increase tamp time, see pages 3.15
	Tamp cylinder does not activate with valve LED indicator OFF and relay LED (on PWB) indicators "ON"	Relay damaged or not seated properly	Replace or reinstall relay
		Connection between relay output and valve faulty	Check connections
	Tamp cylinder does not activate. Relay LED indicators (on PWB) "OFF"	Drive I/O not reaching relay input	Check connections, reseal/replace PWB ribbon cables
		Drive I/O damaged	Replace drive

## Date Code Printer

<b>Problem</b>	<b>Indicators</b>	<b>Remedy</b>
Printer does not cycle and LED on printer valve DIN connector is "OFF" and 24VDC relay LED is dim or "OFF"	Printer is turned off	Turn printer on
	Relay has failed or is not connected	Check relay connections first then replace relay
	Loose connection on relay input to stepper drive #1	Check connections
Printer does not cycle and LED on printer valve DIN connector is "OFF" and 24VDC relay LED is "ON"	Loose connection between relay output and printer valve connector	Check connections
Printer does not cycle and LED on printer valve DIN connector is "ON"	Line pressure is low	Restore system pressure
	Valve or valve coil has failed	Replace valve
Printer fault indicator comes "ON"	Ribbon is empty	Replace ribbon
	End of foil photoeye has failed	Replace photoeye
	Cassette is loose or type holder door is open	Replace cassette and close type holder door
	Switches on the cassette and type holder door have failed	Replace failed switches
Print quality is poor	Insufficient foil pull or air pressure	Restore line pressure and flow pressure
	Printer not level with base	Readjust printer frame
	Temperature too high or low	Adjust temperature by using controller inside the labeler control cabinet
	Dirty, worn, or damaged dies or type	Replace type
	Damaged or out of position print base rubber	Adjust bottom base rubber block to a new position
	Printing foil not compatible with substrate	Contact foil manufacturer
	Label moving before printhead is clear	Increase print wait time
	Print dwell is too low	Increase print dwell time

# *PROGRAM PARAMETERS*

## Program Parameters

The program parameters is a journal of the program's individual settings for up to 21 individual product lines. Each program has unique parameters that can be documented in these charts.

A master copy has been provided on page 9.2, please create a copy and store in the back of this owner's manual.

## Globaal Parameters

The global parameters is a journal of the parameters within the Matrix™ Crossweb Package Labeler.

A master copy has been provided on page 9.4, please create a copy and store in the back of this owner's manual.

# Program Parameters

Program Name or No.			
Parameter No.	Value	Parameter No.	Value
1		8	
2		9	
3		10	
4		11	
5		12	
6		13	
7		--	--

Program Name or No.			
Parameter No.	Value	Parameter No.	Value
1		8	
2		9	
3		10	
4		11	
5		12	
6		13	
7		--	--

Program Name or No.			
Parameter No.	Value	Parameter No.	Value
1		8	
2		9	
3		10	
4		11	
5		12	
6		13	
7		--	--

Program Name or No.			
Parameter No.	Value	Parameter No.	Value
1		8	
2		9	
3		10	
4		11	
5		12	
6		13	
7		--	--

# Program Parameters

Program Name or No.			
Parameter No.	Value	Parameter No.	Value
1		8	
2		9	
3		10	
4		11	
5		12	
6		13	
7		--	--

Program Name or No.			
Parameter No.	Value	Parameter No.	Value
1		8	
2		9	
3		10	
4		11	
5		12	
6		13	
7		--	--

Program Name or No.			
Parameter No.	Value	Parameter No.	Value
1		8	
2		9	
3		10	
4		11	
5		12	
6		13	
7		--	--

Program Name or No.			
Parameter No.	Value	Parameter No.	Value
1		8	
2		9	
3		10	
4		11	
5		12	
6		13	
7		--	--

## Global Parameters

Printer Setup Screen	
Parameter	Value
Printer	
Printer Fault	
Set Temperature	
Printer Dwell	
Printer Wait	
Hot Stamp Heat	

Maintenance Screen	
Parameter	ON/OFF
Predispense	
Optimized	
Non-Stop	
Head-to-Head	
Printer Wait	
Hot Stamp Heat	

Empty Package Screen	
Parameter	ON/OFF
Empty Package Detection	

Misc. Options Screen	
Parameter	Value
Power Up Run/Stop	
Closed Loop	
Label Sensor Logic	
Simultaneous Pull Up	
Film/Package Configuration	
Axis	
Pull Up Drop Delay	
Label Acceleration	
Shift Acceleration	
Step/Servo	

Random Spacing Screen			
Space No.	Value	Space No.	Value
1		6	
2		7	
3		8	
4		9	
5		10	
--	--	11	

# Index

## A

Air Flow Controls 7.3  
Axis 4.26

## C

Caution 1.1  
Change Parameter Instructions  
3.12, 4.28  
Cleaning 4.19  
Cleaning Agents 1.1  
Clear Label 3.17  
Closed Loop 4.26  
Construction IV  
Contrast 4.26  
Copy Program 4.20, 4.21  
Cycles 3.10, 4.26, 4.27

## D

Dancer Operation 3.1  
D a n g e r 1.1

## E

Electrical IV  
Empty Package 4.22, 4.31

## F

Film/Package Configuration 4.26  
Fitting Type/Die Holder 7.2  
Foil Feed Adjusting Screw 7.2  
Foil Threading 7.2

## H

Hazardous Voltage 1.1  
Head-to-Head 4.22, 4.25  
H o m e 3.10  
Hot Surfaces 1.1, 7.1, 7.2

## I

I/O Screen 4.20, 4.21  
Installation Guidelines 1.2

## L

Label Acceleration 4.26, 4.27  
Label Brake Arms 3.1  
Labeler Speed 8.9  
Label Gap 4.27  
Label Length 3.11  
Label Reel 3.1  
Label Sensor 3.4, 3.16  
Label Sensor Distance 3.11  
Label Sensor Logic 4.26  
Label Sensor Set 3.9  
Label Speed 3.11  
Labels per Row 3.11  
Language Selection 4.28  
Load Program 3.9, 3.14  
Low Label 4.22, 4.31

## M

Magazine Removal 7.2  
Main Menu 3.9  
Main Signal Logic 4.26  
Maintenance 3.9  
Maintenance Log 4.34  
Measure Label 3.9  
Model Identification 2.1  
Move Motors 4.20  
Multiple Offsets 4.30  
Multiple Spaces 4.30

## N

Name Program 3.9, 3.14  
Non-Standard Placement 4.22,  
4.29  
Non-Stop 4.22, 4.24  
Number of Rows 3.11

## O

Offset Distance 3.11  
Operation Instructions 3.2  
Optimize 4.22, 4.23  
Options 4.20, 4.22

## P

Passwords 4.20, 4.32  
Peel Bar 3.1, 3.4  
Personal Safety 1.1  
Placement of Product 3.1  
Powe r 2.1  
Power Requirements 2.1  
Power Up Run/Stop 4.26  
Pre-Run Checklist 3.1  
Predispense 4.22, 4.23  
Printer Safety 7.1  
Printer Setup 3.9, 7.4  
Printhead 7.3  
Printhead Temperature  
Adjustment 7.3  
Print Orientation 7.3  
Prior to Cleaning 4.19  
Pull Up Drop Delay 4.26, 4.27

## R

Re-Fitting Foil Magazine 7.2  
R ow 3.10  
Row Distance 3.11  
Row Offset 3.11  
Row Shift Speed 3.11  
Run Labeler 3.9  
Running/Cycles 3.10

## S

Safety Guidelines 1.2  
Security 3.15  
Serial Number 2.2  
Service Log 4.34  
Servo Safety 4.33  
Shift Acceleration 4.26, 4.27  
Signal Indicator 3.10  
Simultaneous Pull Up 4.27  
Spare Parts 6.1, 7.5  
Spread Distance 3.11  
Step/Servo 4.26  
Stepper Drive ResistorLocations  
5.1  
Stop 3.10

EXPRESS ON-LINE SPARE PARTS  
[www.baumann-industries.com](http://www.baumann-industries.com)



Technical Support  
+61 (0) 423 544 686



**For Global Support, Call Baumann:**  
Phone: +61 02 720 521 70  
[sales@baumann-industries.com](mailto:sales@baumann-industries.com)  
[www.baumann-industries.com](http://www.baumann-industries.com)