

MODEL SMARTVAC Basic line



Compact thermoforming packing machine.
Top technology. **"Made in Germany"**

SUITABLE FOR THE USE OF RIGID OR SOFT FILM.

Basic construction:

Stainless steel and anodized aluminum construction, electric and pneumatic equipment, film drive by stainless steel gripper chain, electronic control of advance pitch, forming stations, sealing and cutting with relative mechanical raising units, touch-screen control panel.

Use of standard parts from brand-name manufacturers with their own worldwide distribution network, ensures simple procurement of replacement parts.

The SMARTVAC is the perfect machine for contract packagers and manufacturers serving the food Industry.

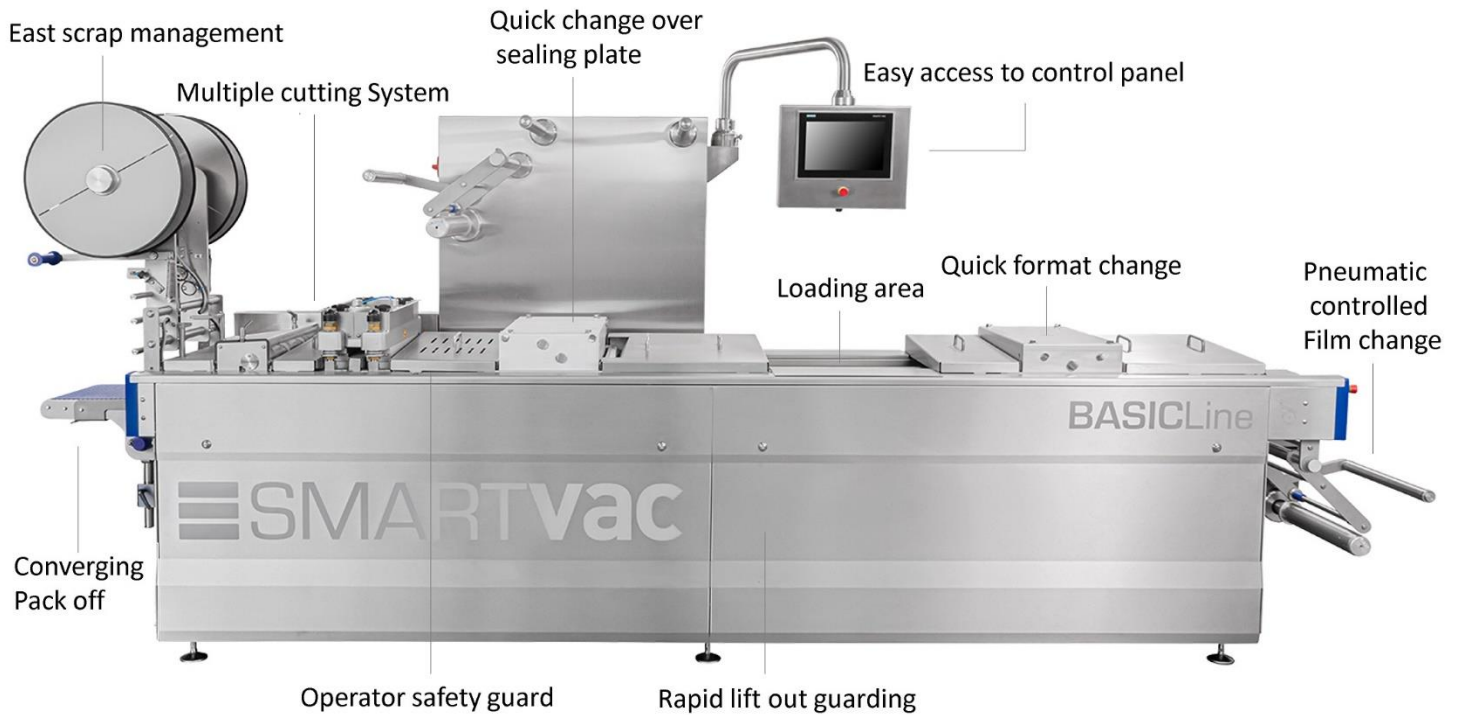

EQUIPMENT SPECIFICATION

- Base web and top web unwind units with pneumatic stop and end of reel detectors.
- Temperature of plates checked individually through PLC.
- Pneumatic lifting units for pre-heating, forming, and sealing stations.
- Loading area 860 mm. long for manual feeding, with predisposition for automatic feeding.
- Sensor to check product protruding before sealing station.
- Photocell for printed top film.
- Die set equipped with gaskets.
- Euro hole cutting station.
- Motorized outfeed conveyor belt, 350 mm long.
- Inline labelling system.



- **Designed for a variety of applications**
- **Stainless steel construction**
- **IP – 65 class protection**
- **12 “Touch screen**
- **Modem for teleservice**
- **Vacuum and MAP packing systems**
- **Suitable for semi rigid and flexible film**
- **Economic film consumption**
- **Easy access for tool change over**
- **Servo drive system**
- **Vacuum pump for forming station.**
- **Automatic lubrication system.**

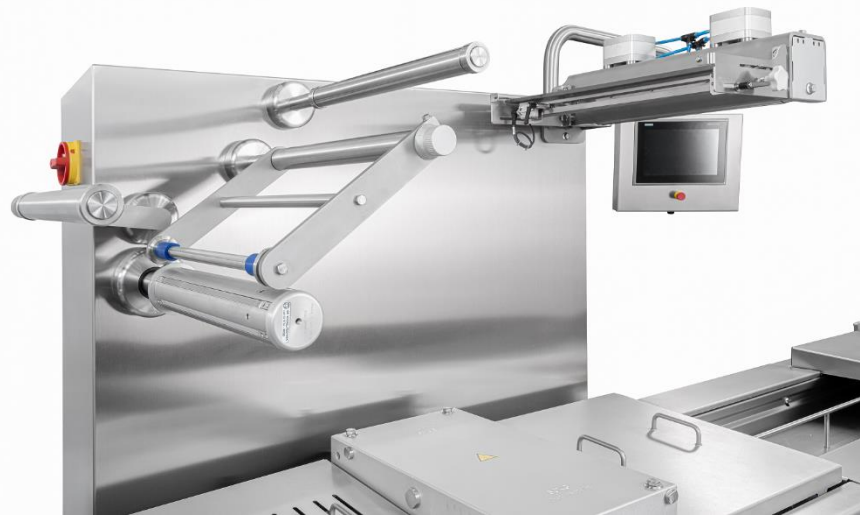

Technical Data	SmartVac Basic Line
Machine Length	4000 – 6000 mm
Height of loading platform	950 mm
Film width max.	460 mm
Packing depth max.	100 mm (190 mm upon request)
Extraction length	300 mm max.
Width of the machine	1200 mm
Machine speed	5 – 15 cycle / minute
Compressed air	6 bar
Electrical requirements	Three-phase+ neutral + earth 50Hz
Machine weight	Approx. 1600 kg.

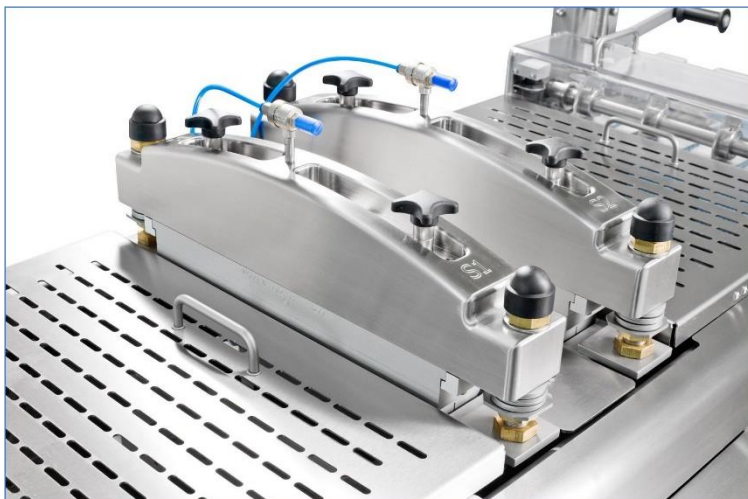

ADVANTAGES

- Each machine is customized and tailored according to customers need.
- Fully wash down system.
- High performance low maintenance.
- Reliable forming and secure sealing.
- Each mechanical part is made by Hilutec.
- Operating friendly design.
- Remote Support Management (RSM).