

GWX MAXI Plus

Weigh price labeller



The GWX MAXI Plus range
Weigh price labeller

RS BILANCE

MAIN FEATURES

- Cadences up to:
 - **30 ppm** model 30P (Stop and go operation).
 - **60 ppm** model 50P (Dynamic operation).
- Capacity: 15/30 kg - 5/10 g.
- From 2 to 3 motorized belts, with closed loop.

Model 30P useful belt size [mm]

CADENCE	WEIGHING	LABELING
-	320x600	320x1200/1600
-	420x600	420x1200x1600
-	510x1000	510x1200/1600

Model 60P useful belt size [mm]

CADENCE	WEIGHING	LABELING
320x600	320x600	320x1200/1600
420x600	420x600	420x1200/1600
510x1000	510x1000	510x1200/1600

- Brushless motors and drive cards, speed up to 50 m/min.
- Working temperature: from 0 °C to + 40 °C.
- Power supply: 230 Vac (Hz 50/60).
- Consumption: 2 belts 2,05 kW, 3 belts 2,9 kW.
- Resistive PC/Panel 10" display.
- Structure and carpentry in aluminium and stainless steel.
- Machine management P.L.C.
- Thermal and/or direct transfer.
- Resolution: 8 dots/mm, **203 dpi** (optional: 12 dots/mm, 300 dpi).
- Print speed: 203 dpi, **457 mm/s** - 300 dpi, **300 mm/s**.
- Label sizes: from 40x40 to 110x110.
- Print width: 104 mm.
- Internal diameter of the roll: 76 mm.
- External diameter of the roll: **300 mm**.
- Label application with compressed air (**AIR BLAST**), 6 bar 60 l/min, multi-label firing chamber with mechanical adjustment and position indicator.
- Label application through **rotary pneumatic arm** with sponge application plate, consumption 4/6 bar 40 l/min.
- **Horizontal, vertical and rotational (180°)** mechanical movement of the printing unit.

Selectable Functions

- **SOFTWARE:**
 - ✓ Price weight program.
 - ✓ Multi language selection.
 - ✓ Password on multiple levels.
 - ✓ Remote assistance on request.
- **PLU:**
 - ✓ Number of plu: 9999.
 - ✓ For each plu:
 - ☑ 5 text fields, each of 500 characters (for example: ingredients, allergens etc ..).
- Able to print in bold, italic, underline, font single.
- Supports different types of characters, not just by line.
- Automatic parameter programming (motor speed, minimum and maximum weighing threshold, duration and expulsion delay, label and variable application along the X axis).
- **TRACEABILITY:**
 - ✓ Maximum number of lots: 9999.
 - ✓ For each lot:
 - ☑ 10 lines of 50 characters each for the data sent from the back office.
 - ☑ Or the manual entry of data (scanner for EAN128 ?).
 - ☑ Weight limit with configurable alarm.
 - ☑ Expiry date with configurable warning.
- **LABEL FORMATS:**
 - ✓ Customizable label formats: 1000. (print format can be modified on the machine).
 - ✓ Rotation of the label format: 0, 90, 180, 270.
 - ✓ Rotation of fields.
- **NUTRITIONAL DATA:**
 - ✓ Print nutritional data in table format.
 - ✓ Print data for standard dimensions (100 g) and/or per portion.
 - ✓ RDA printing.
- **TOTALS:**
 - ✓ Sub-total, general, grand total.
 - ✓ Totals for PLU.
 - ✓ Totals per traceability lot, lot/PLU.

I/O Section

- 1 USB 2.0.
- 1 Ethernet.
- 2 Electrical signals (clean contacts).

Diagnostics

- Continuous monitoring of the status of the machine and of all integrated systems (downstream consent, motor failure, overall dimensions on belts and all errors resulting from the printing system like paper end, ribbon end, paper pass and printhead wear).

Options

- 300 dpi print resolution, 300 mm/s speed.
- Bench-top labeller for totalizations.
- 2D camera for label presence.
- 2D camera for QR Code reading.
- External PROFIBUS interface, Profibus protocol with PCB.
- Communication protocol ETHERCAT.
- Pair of STAINLESS STEEL products guide.
- Piston ejector, arm or pneumatic blow.
- Collection basket in STAINLESS STEEL and plastic.
- Waste roller conveyor with collection basket.
- Notice of full collection basket.



Dimensions

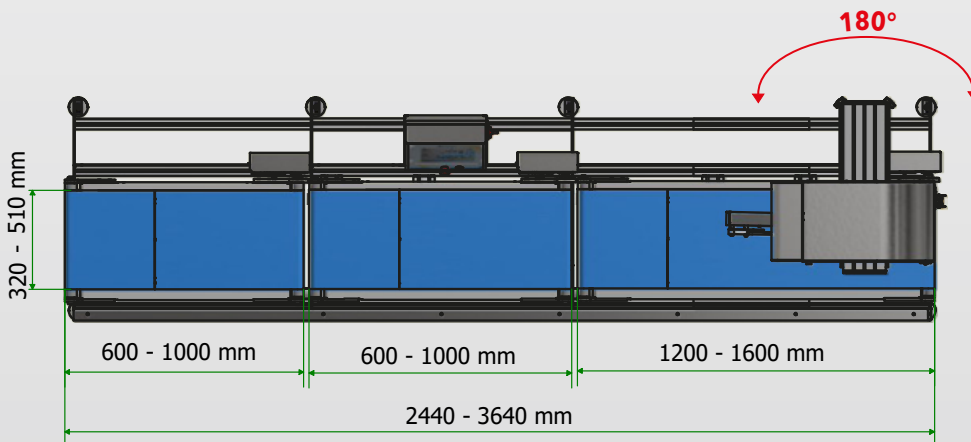
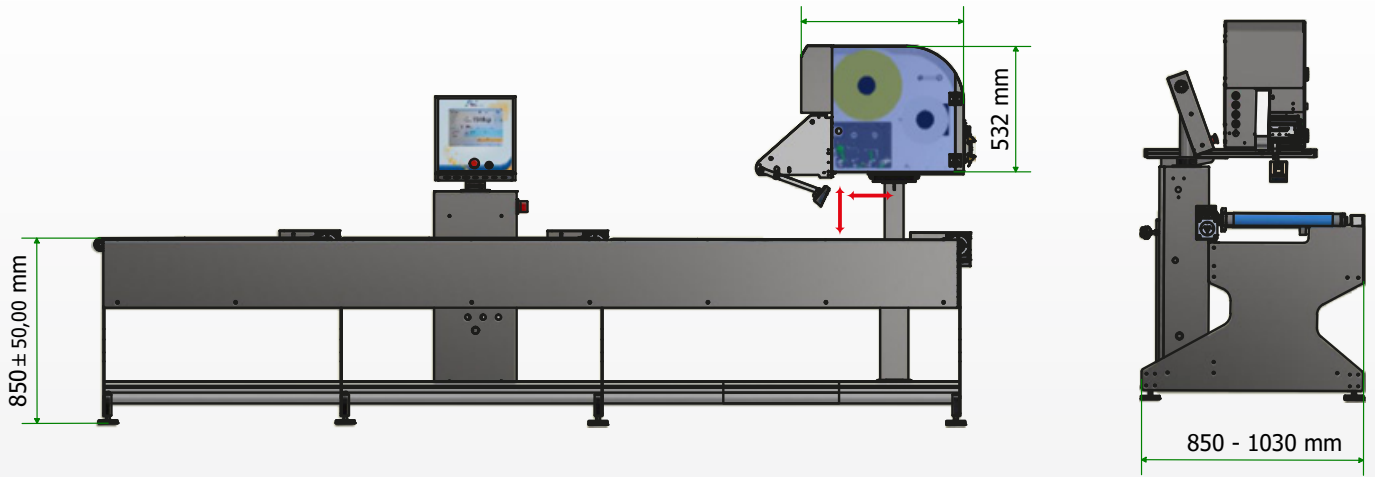

Technical specifications and images may be subject to improvements and modifications