

Baumann Engineering guarantees value for money by supplying modern technology of first-class design and expertise.

## **CWL - SERIES 100-S LABEL APPLICATOR**

*Conveyor belt In - Line Labeller*

The CWL-100 labelling system is the ideal overall solution if you want to precisely apply labels of almost any size and shape.



The CWL 100 self-adhesive label applicator is designed for flexible integration in to packaging lines, where production speeds, accuracy and reliability are important.

The modular design allows a high degree of flexibility when it comes to labelling products of any conceivable form.



Whether for the food or non-food industry, our high-performance CWL-100 labelling system solves any task with great precision.

Quick change over, almost no maintenance requirements, and individual adaption of operating parameters through user friendly HMI touch screen are among the out standing advantages of Baumann Engineering technology.

**Features**

- Designed for horizontal labelling
- Constructed of S/S and Aluminium
- Transport products up to 250 mm wide
- Conveyor speed up to 35 m/min.
- Integrated encoding system
- Locking casters
- Small footprint

**Industries**

- ✓ Food
- ✓ Pharmaceutical
- ✓ Chemical
- ✓ Cosmetic
- ✓ Automotive
- ✓ Others

**Technical data**

Label strip width	30, 50,100 mm (Optional 150 mm)
Label transport length	Continuous – automatic length measuring
Label rolls	
Core	40/76 mm
Outer diameter	360 mm
Inside or outside winding	
Label speed	Up to 40 m/min. standard Higher speed optional
Label accuracy	+/- 0.5 mm (depending on machine execution & product)
Power supply	220 V, 55 Hz

The CWL Labelling Technology has been designed in such a way that it can be assembled cost effectively to obtain individual labelling solutions based on proven modules.

## HMI Controller

	<ul style="list-style-type: none"> <li>➤ 10 " Touch screen</li> <li>➤ IP - 65 Protection</li> <li>➤ All in One programmable control panel</li> <li>➤ Fast and easy program storage</li> <li>➤ Status report and diagnose function</li> <li>➤ Data transfer for external logistical systems</li> <li>➤ On-screen fault system</li> <li>➤ Password protected maintenance screen</li> <li>➤ Product counter</li> <li>➤ End of label supply warning light</li> <li>➤ Missing label detection</li> <li>➤ Interface module</li> <li>➤ Compact Unit</li> </ul>
---	---

## Labelling head

- Labelling head, PLC controlled display with digital input for ease of operation
- Photoelectric label scanning with automatic adjustment to label length
- Rewind device for spent backing paper to eliminate repeated backing paper removal during operation
- Label head mounted on gantry mechanism
- All wire connections are plugged / No hard wiring
- Labeller available in left to right or right to left configurations
- Allows infinite vertical and horizontal adjustments along frame

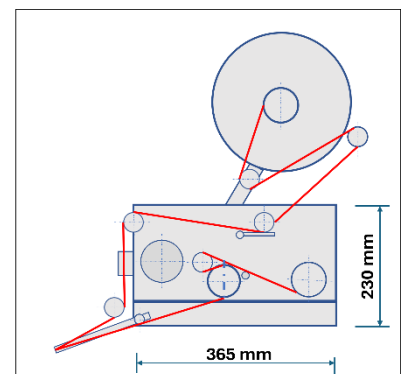
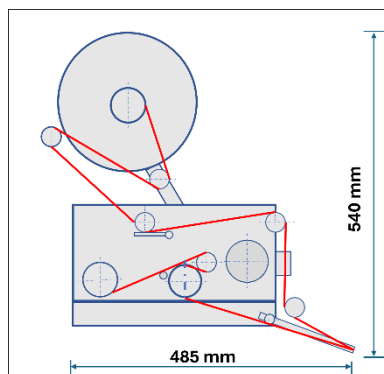

This portable CWL - 100™ in line labeller is the perfect cost-effective solution for any packaging line. You will be amazed at the unmatched speed, precision, and versatility delivered by the CWL – 100.