

EXTERNAL SPACE
112.53 m²

1
4000
Survey information: Ground floor
scale 1:50 @A3

N

0 0.5 1 2 m

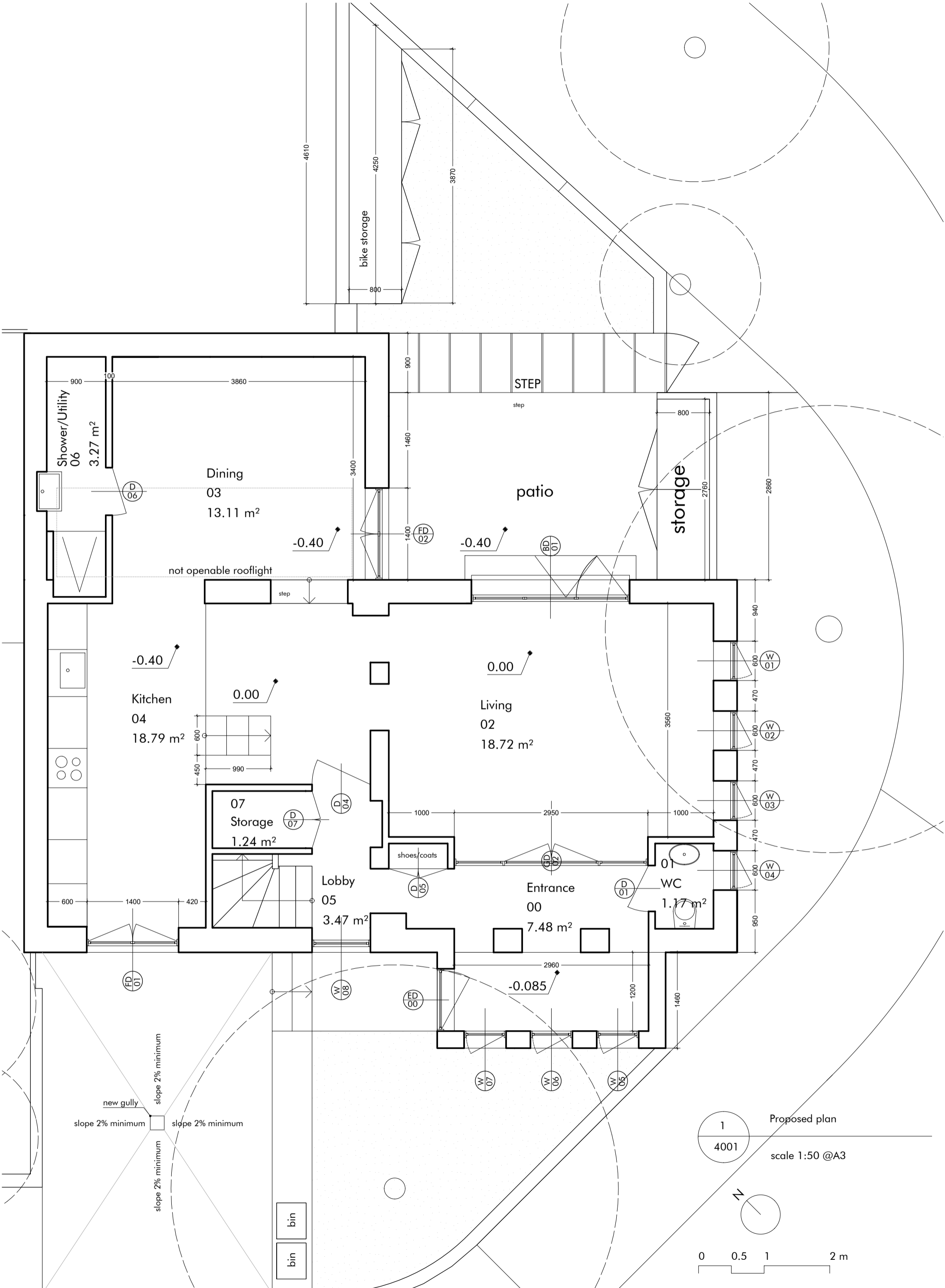

new gully
 slope 2% minimum
 slope 2% minimum
 slope 2% minimum
 slope 2% minimum

1
 4001
 Proposed plan
 scale 1:50 @A3
 0 0.5 1 2 m

Revision Release date Drawn/Checked NOTES

archetypes.
 design

projects@archetypes.design | archetypes.design | 07473 949960

PROJECT ADDRESS London SE16 6RZ

CLIENT Alfredo and Ana Bianco

DRAWING TITLE Plan as proposed
 DRAWING NO AD22.05 MDR 4001

PURPOSE OF ISSUE Preliminary Pricing

SCALE 1:50

FORMAT A3

STAGE 1

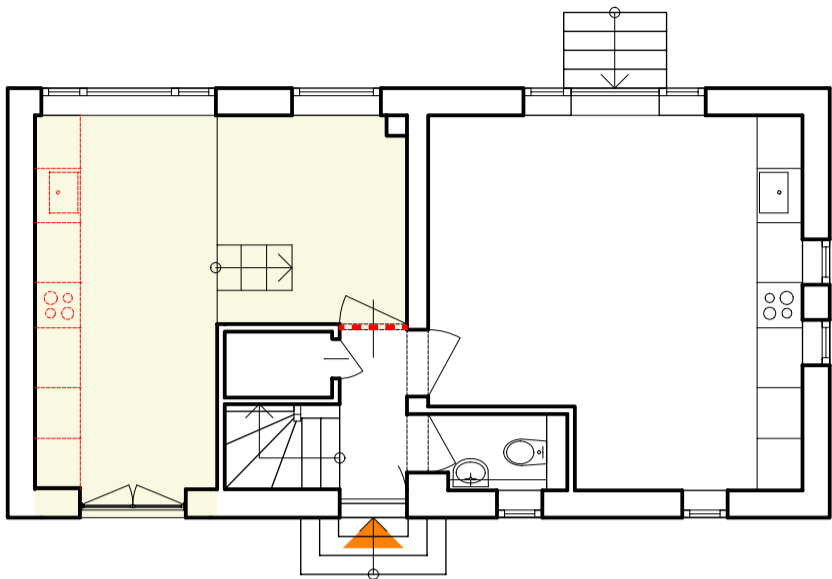

STAGE 1

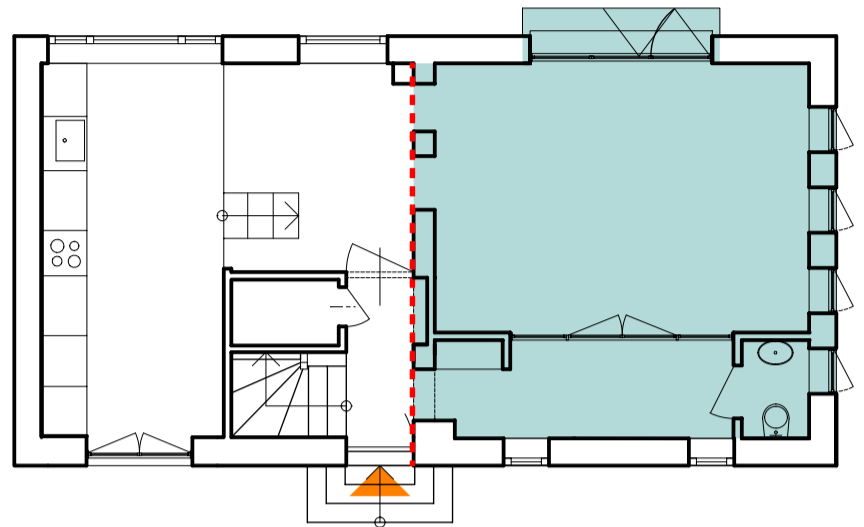

STAGE 3

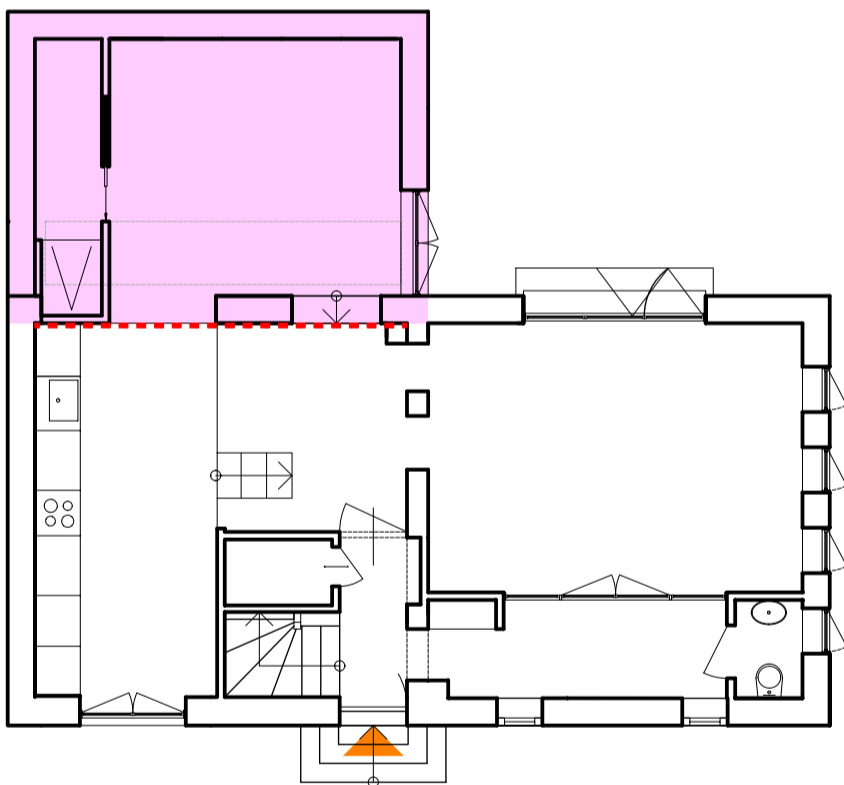

STAGE 4

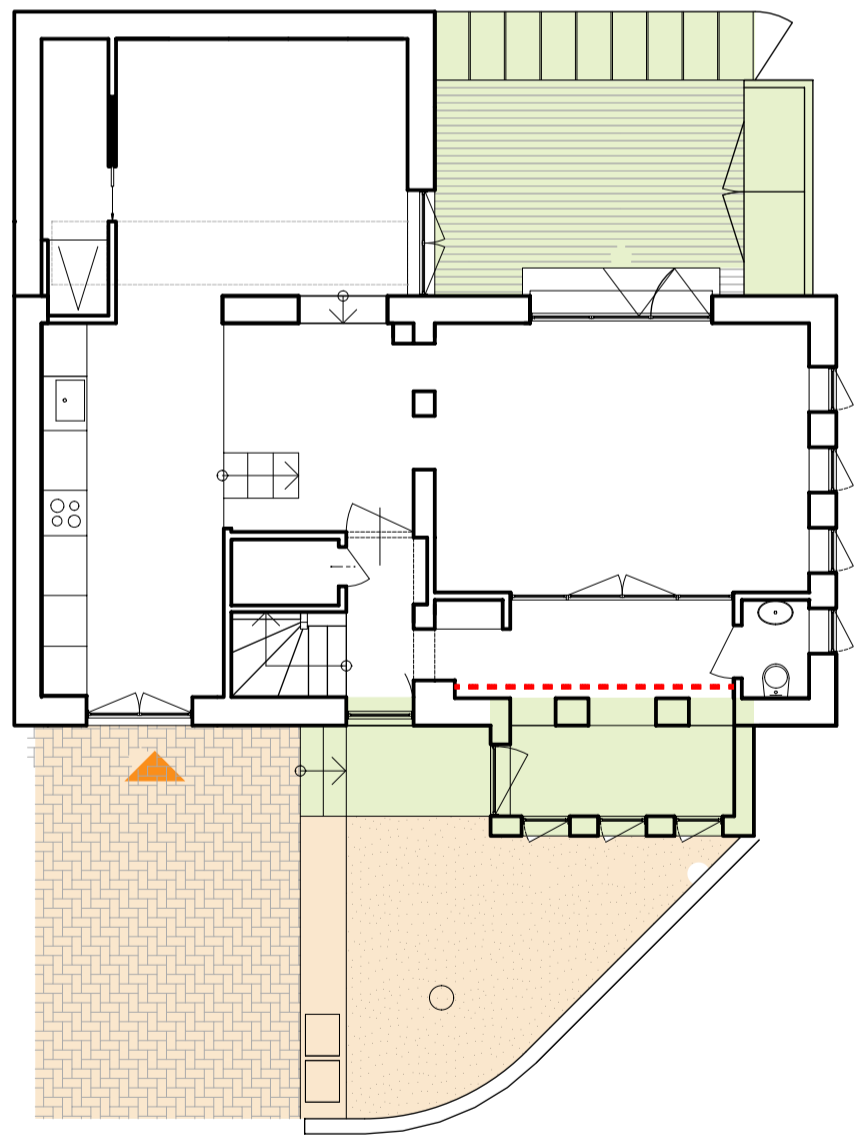

STAGE 5

1
4002

Stages

scale 1:100 @A3

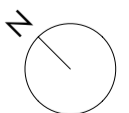

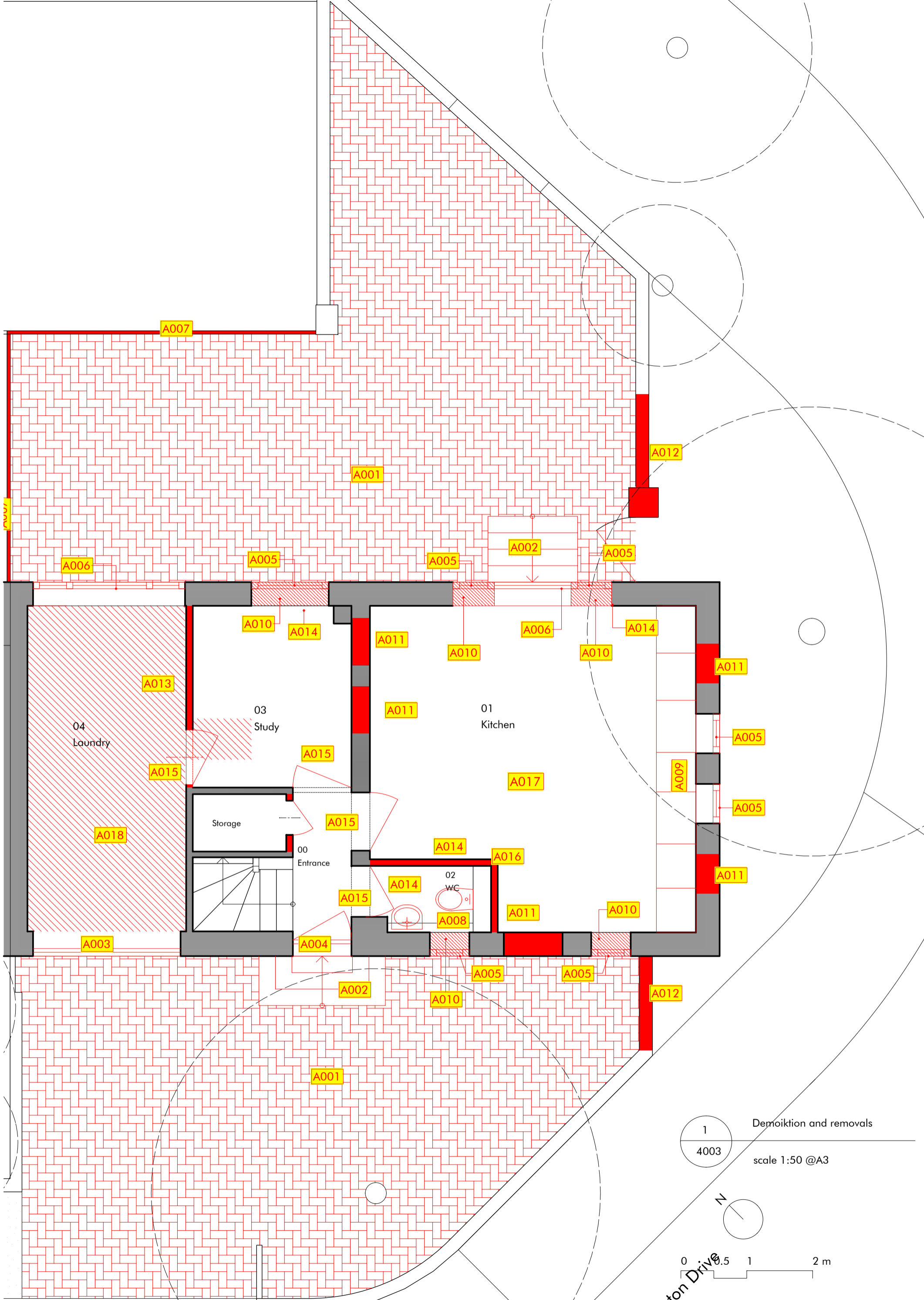

1 Demolition and removals
 4003
 scale 1:50 @A3

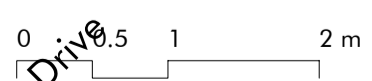
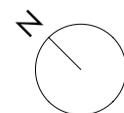

Revision Release date Drawn/Checked NOTES

archetypes.
 design

projects@archetypes.design | archetypes.design | 07473 949960

PROJECT Demolition and removals
 DRAWING NO AD22.05 MDR 4003

ADDRESS London SE16 6RZ

CLIENT Alfredo and Ana Bianco

PURPOSE OF ISSUE Preliminary Pricing

SCALE 1:50

FORMAT A3

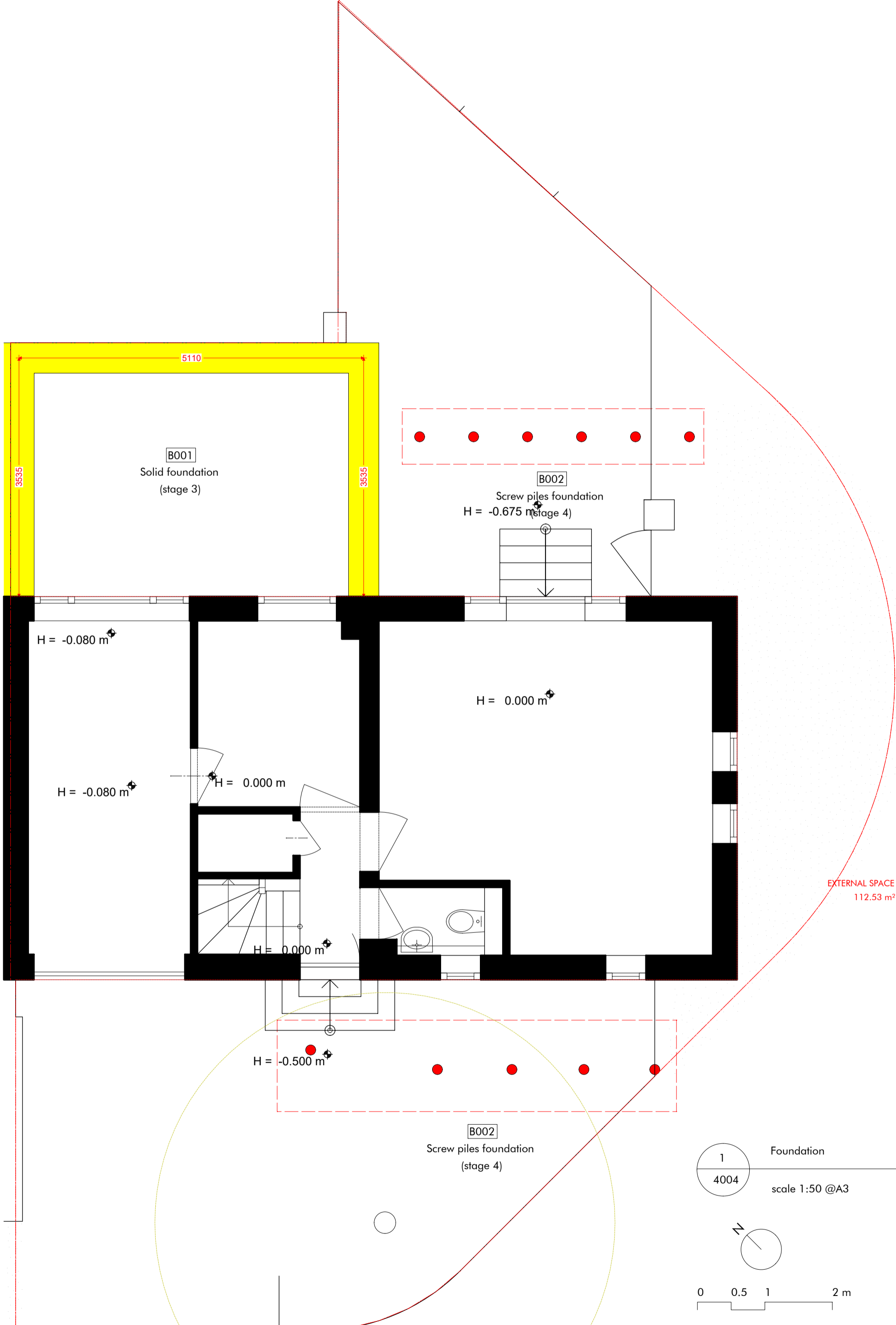

EXTERNAL SPACE
112.53 m²

1 Foundation
4004
scale 1:50 @A3

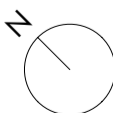

0 0.5 1 2 m

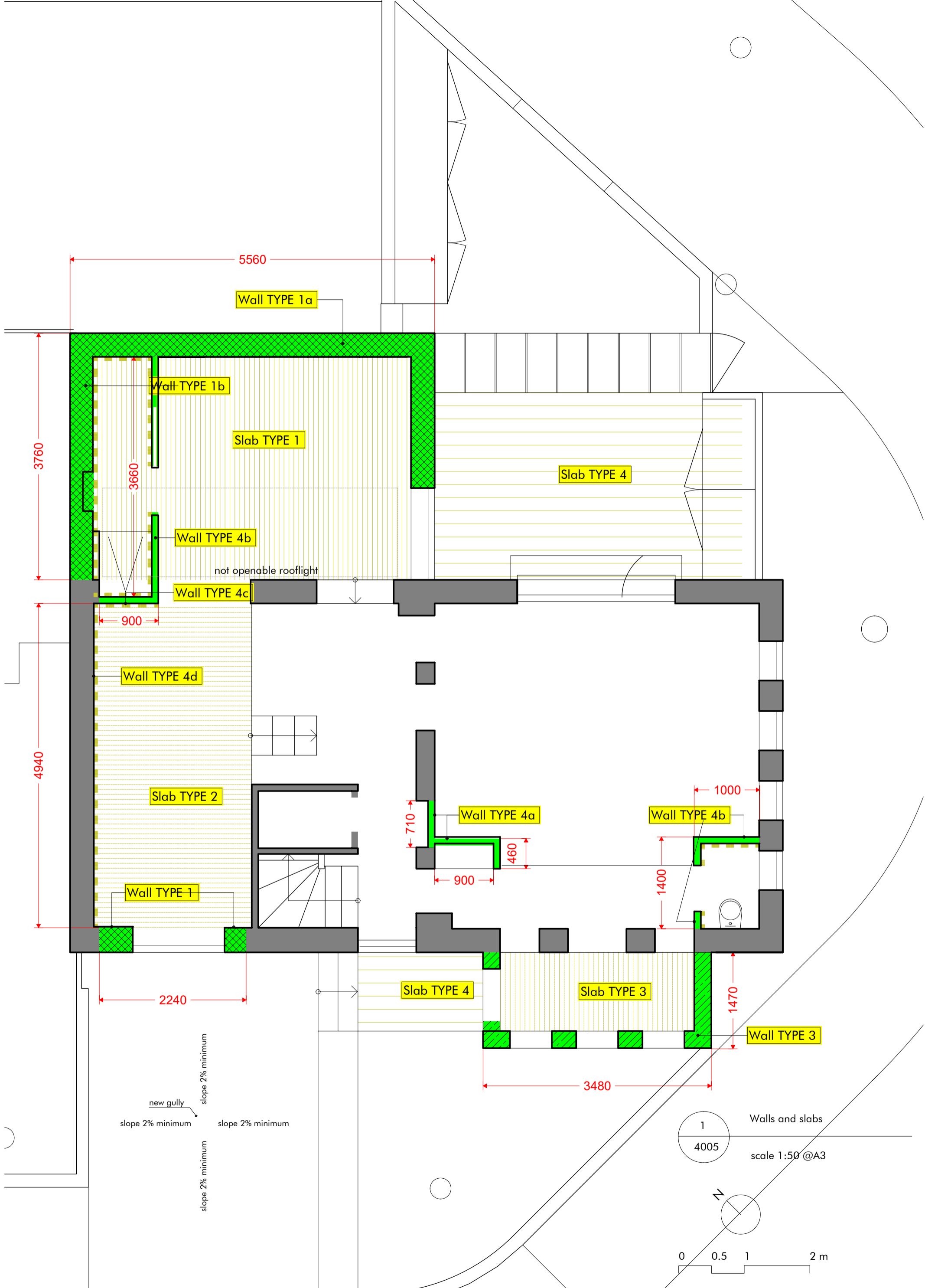

Revision Release date Drawn/Checked NOTES

WALL TYPES

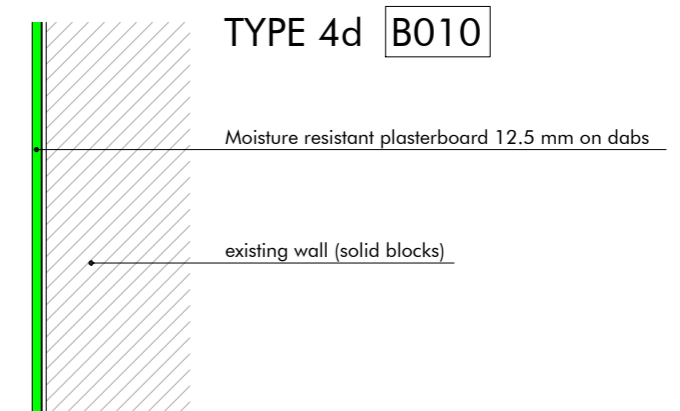
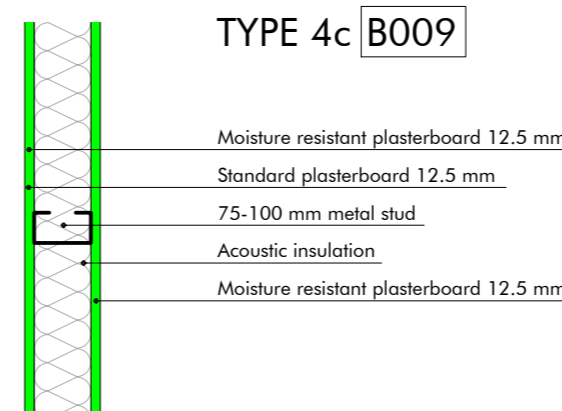
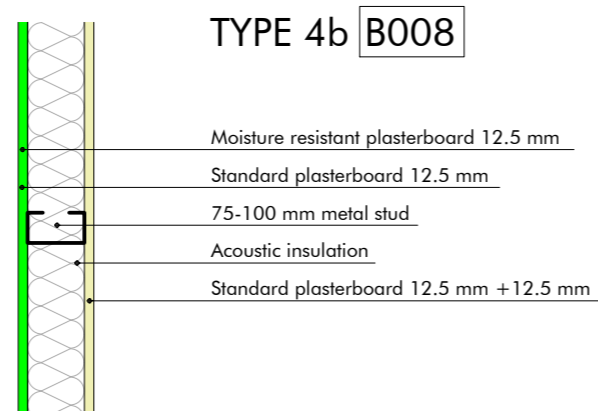
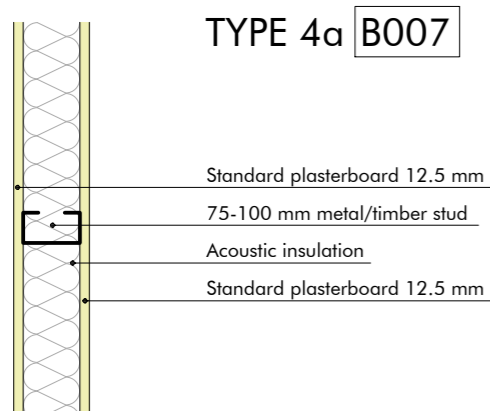
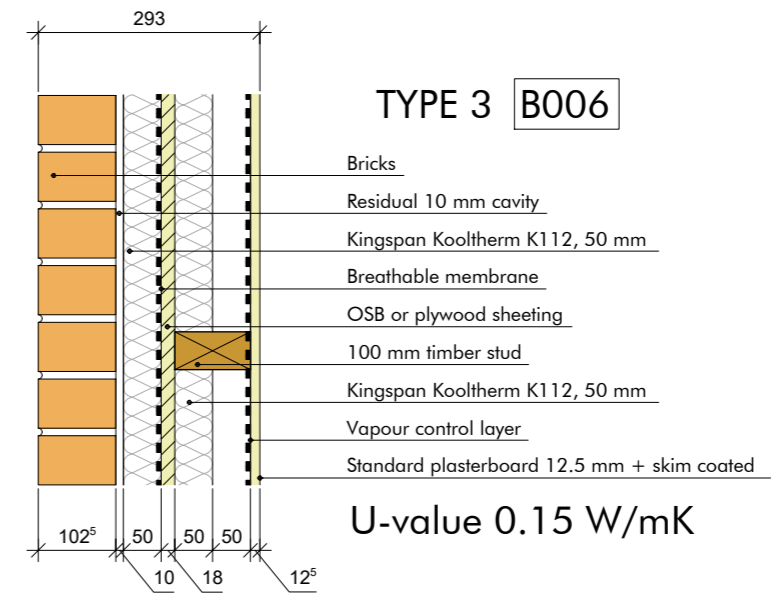
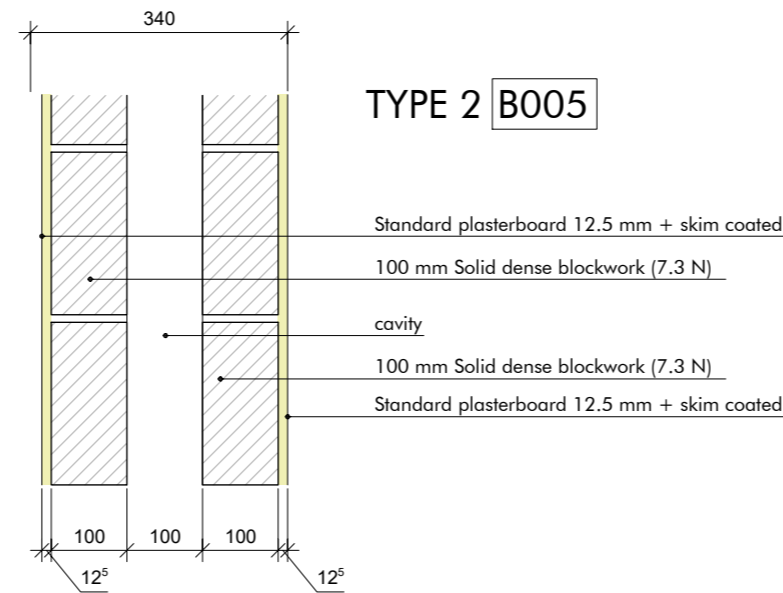
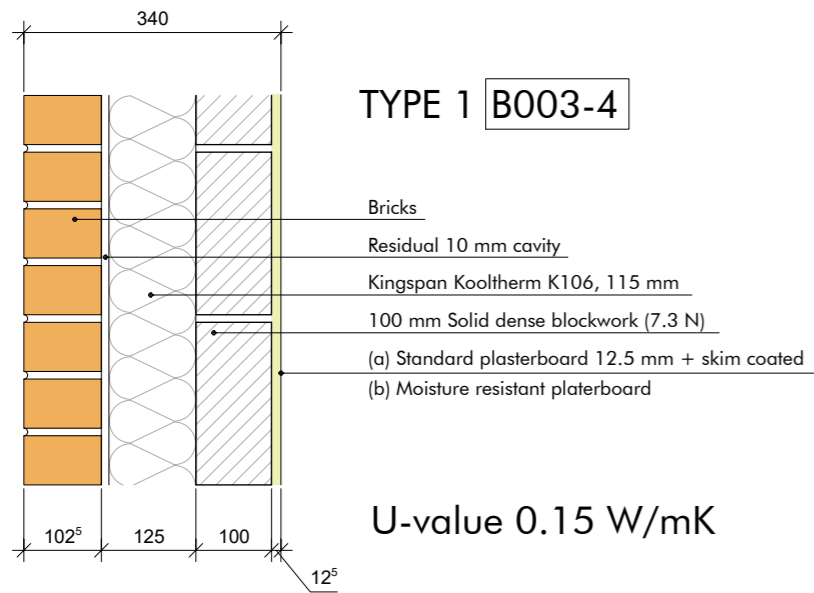

SLAB AND ROOF TYPES

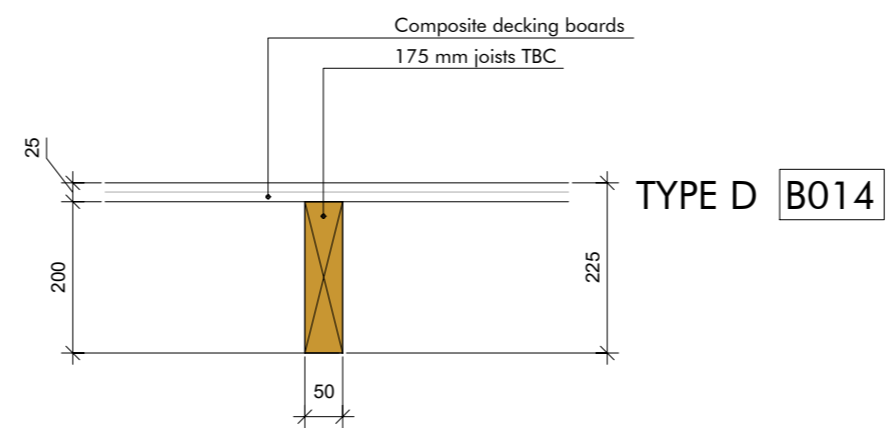
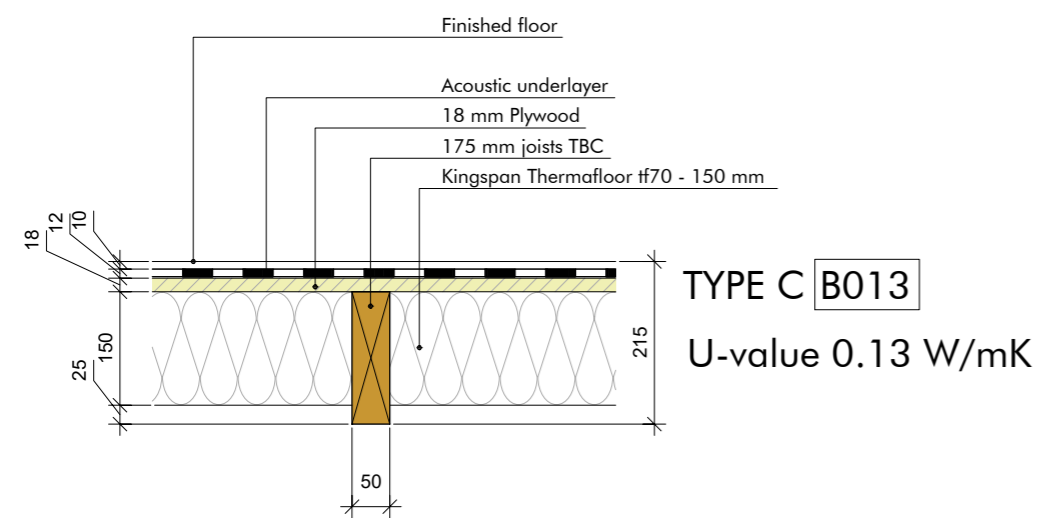
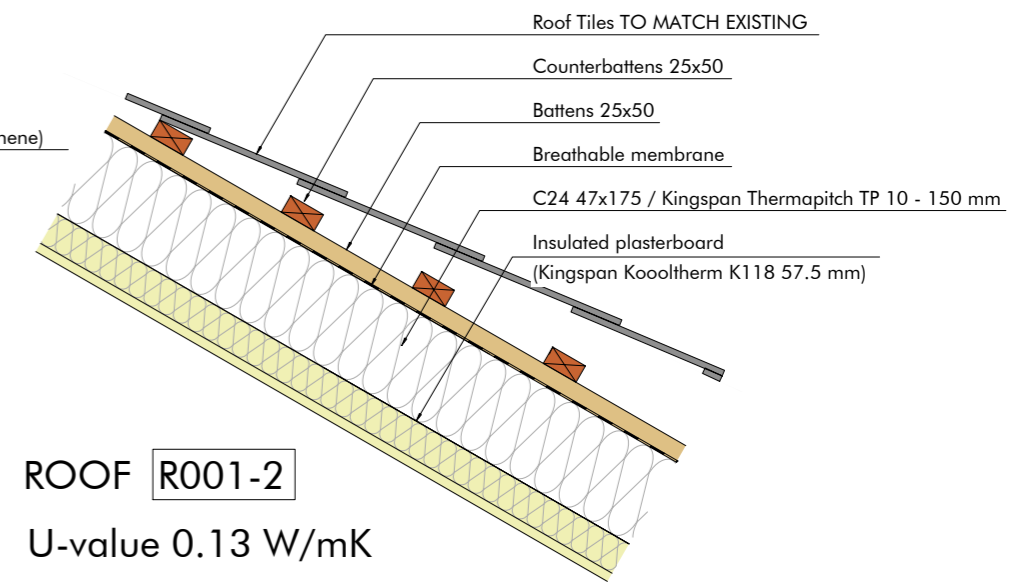
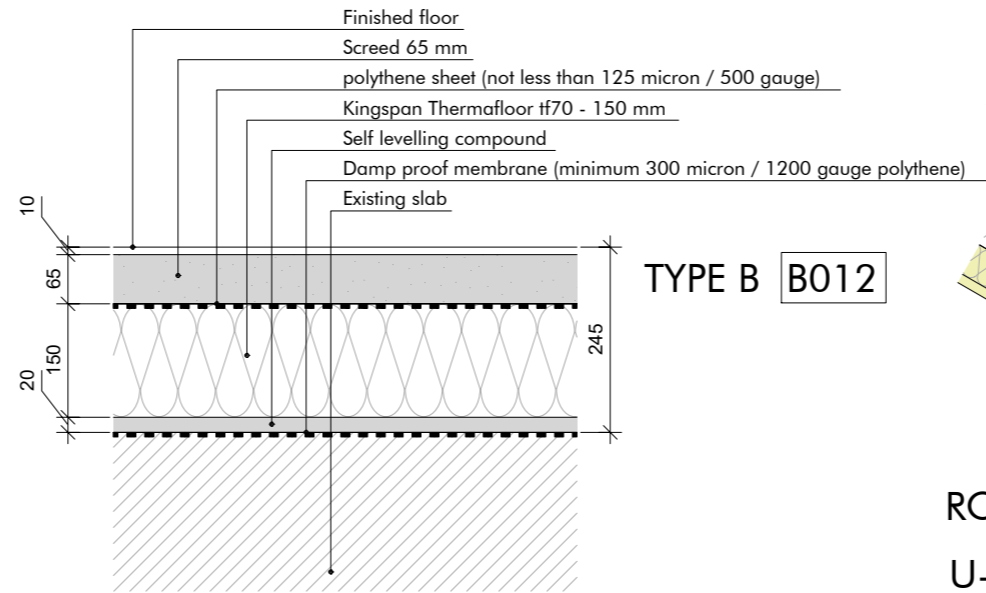
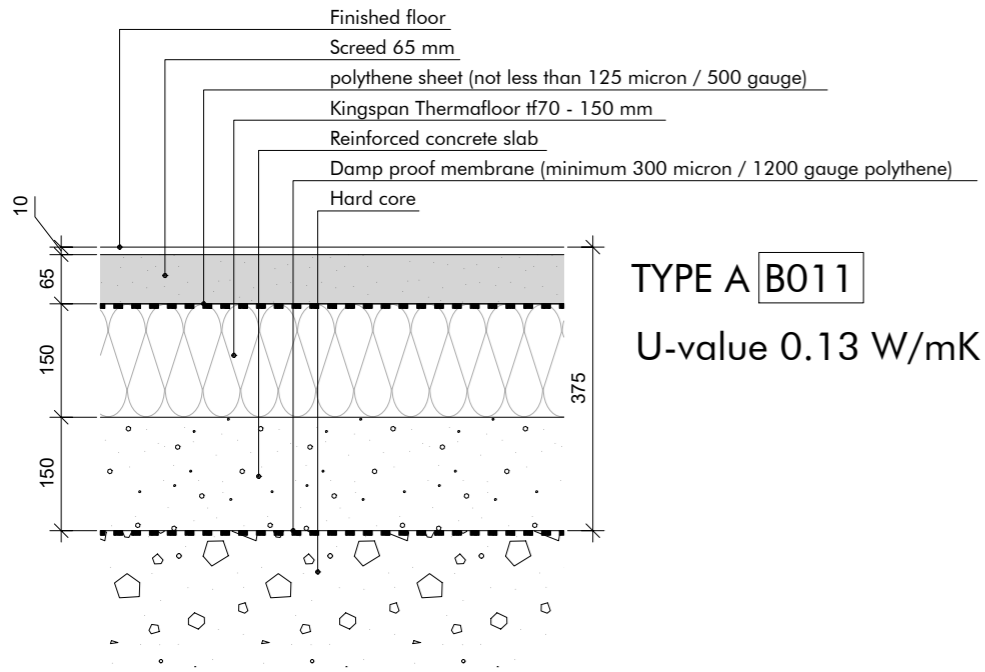

1
 4007
 Salbs and roof
 scale 1:10 @A3

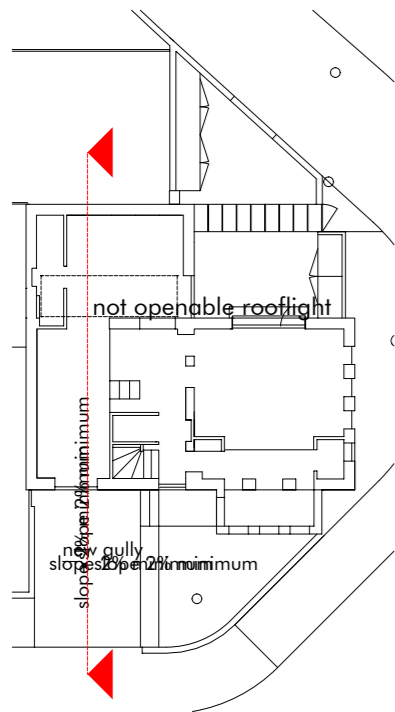

1
 4008
 Section 1-1
 scale 1:20 @A3

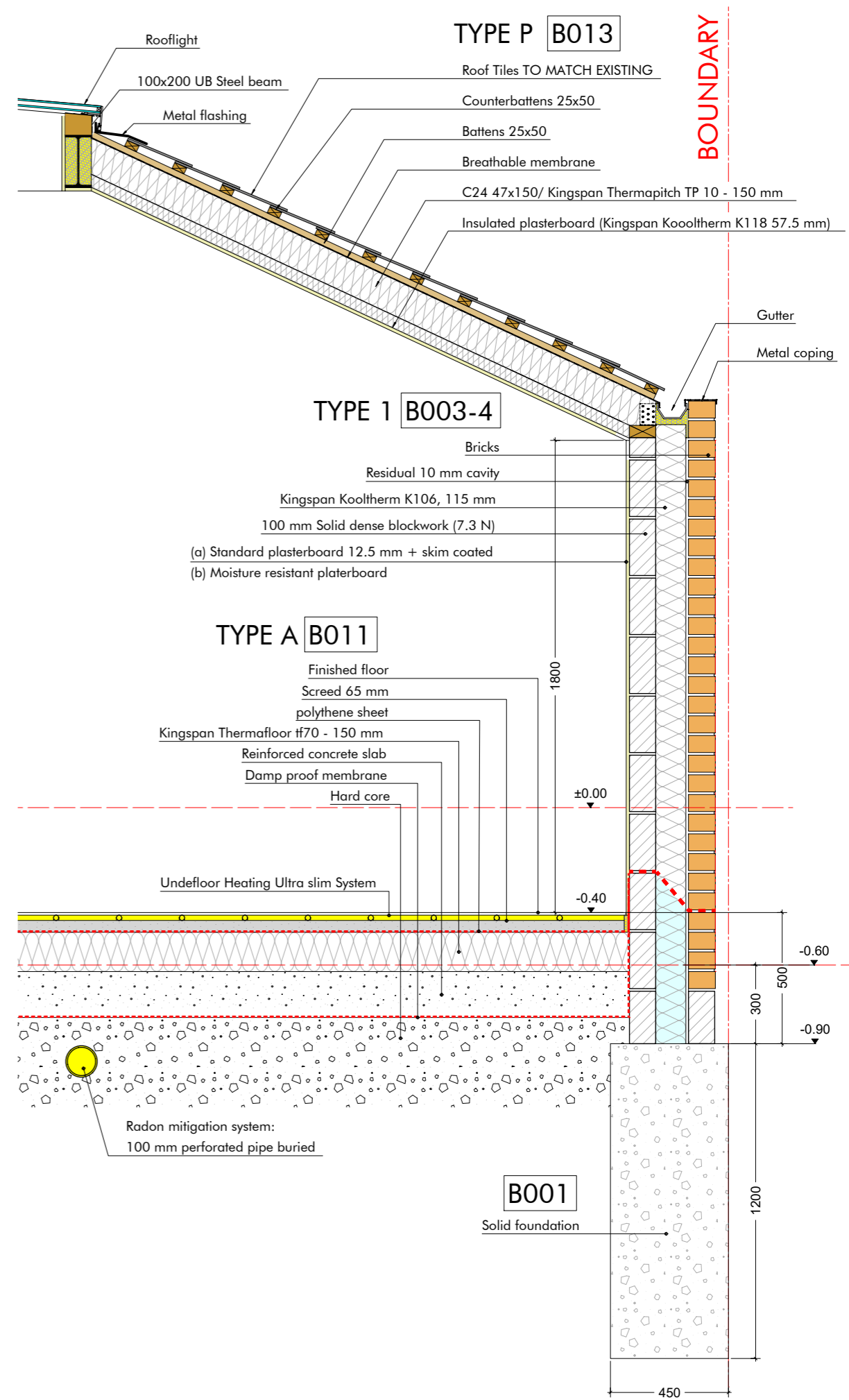
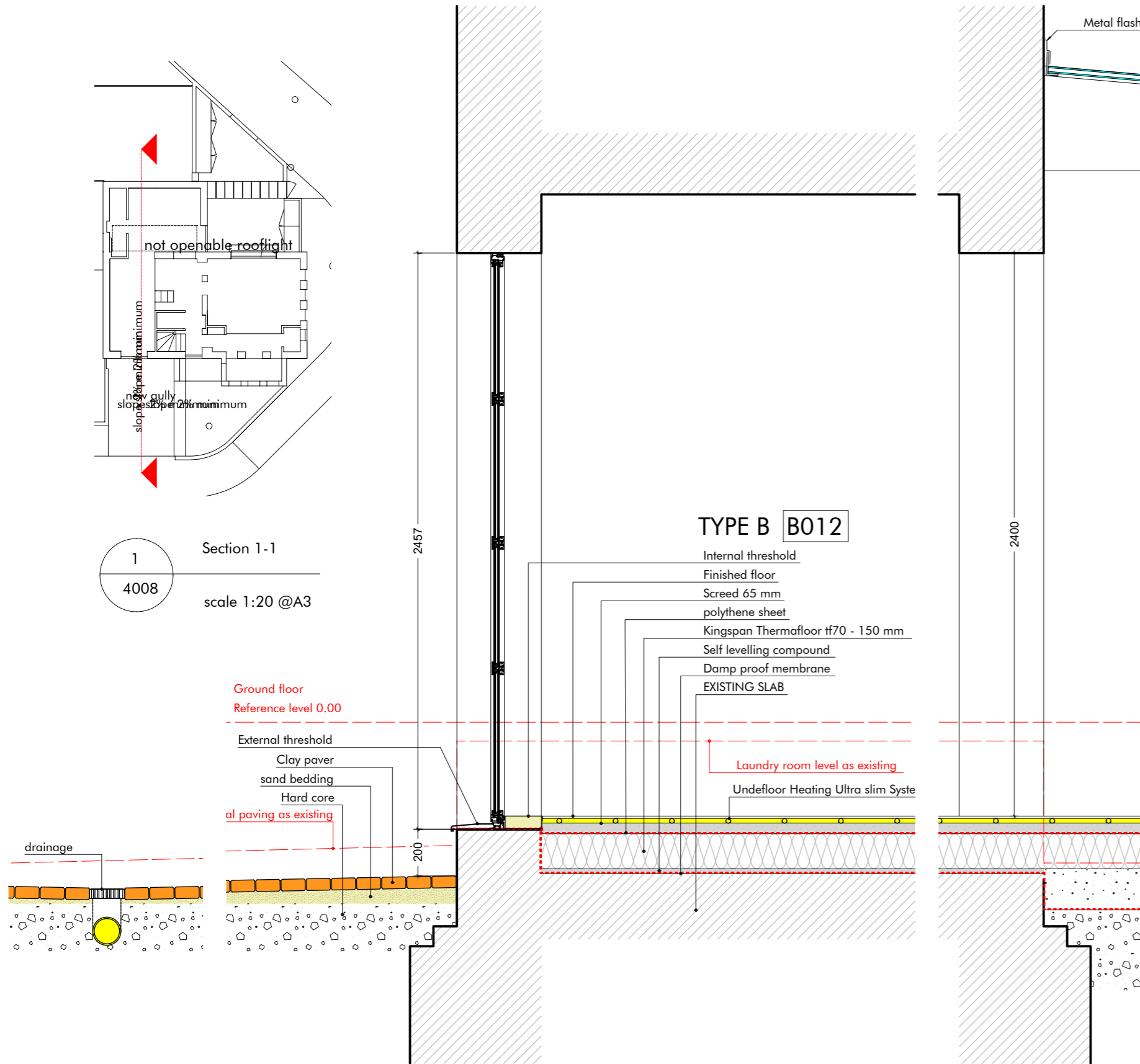

TYPE P B013

- Roof Tiles TO MATCH EXISTING
- Counterbattens 25x50
- Battens 25x50
- Breathable membrane
- C24 47x150/ Kingspan Thermapitch TP 10 - 150 mm
- Insulated plasterboard (Kingspan Kooltherm K118 57.5 mm)

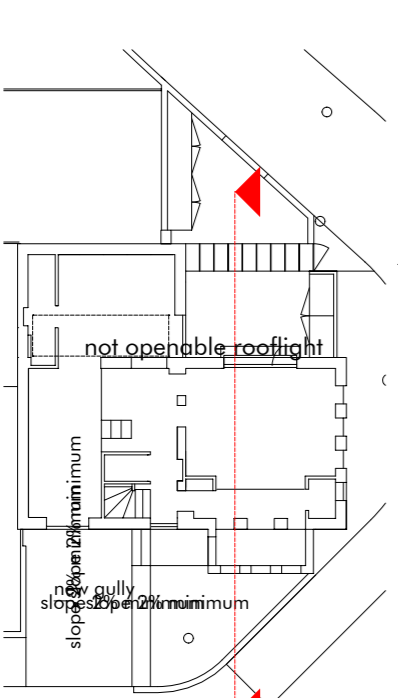

- Gutter
- 100 mm timber stud
- Kingspan Kooltherm K112, 50 mm
- Vapour control layer
- Standard plasterboard 12.5 mm + skim coated

1524

TYPE C B013

TYPE 3 B006

- Bricks
- Residual 10 mm cavity
- Kingspan Kooltherm K112, 50 mm
- Breathable membrane
- OSB or plywood sheeting

- internal sill (timber, painted)
- skirting
- Finished floor
- Acoustic underlayer
- 18 mm Plywood
- 175 mm joists TBC
- Kingspan Thermafloor tf70 - 150 mm
- Undeefloor Heating Ultra slim System
- membrane
- heavy duty steel lintel
- new levelled gravel
- triple joist TBC
- joist hanger

External paving as existing

screw pile

2330

2050

2050

stone step

300

300

metal slab 2100x600x20

133 + 133 + 133

400

timber joist TBC

TYPE D B014

composite patio decking

triple joist TBC

concrete slab

900





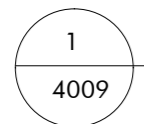



screw pile

BOUNDARY LINE



Section 2-2
scale 1:20 @A3

LEGEND

-  Shaver socket – 115v and 230v
-  Dimmable LED wall light
-  13amp single socket
-  DIMMABLE PENDANT
-  13 amp double socket wall-flush
-  Dimmable LED fixed downlight
-  Electric board + SPUR Switches
-  non-dimmable LED fixed downlight

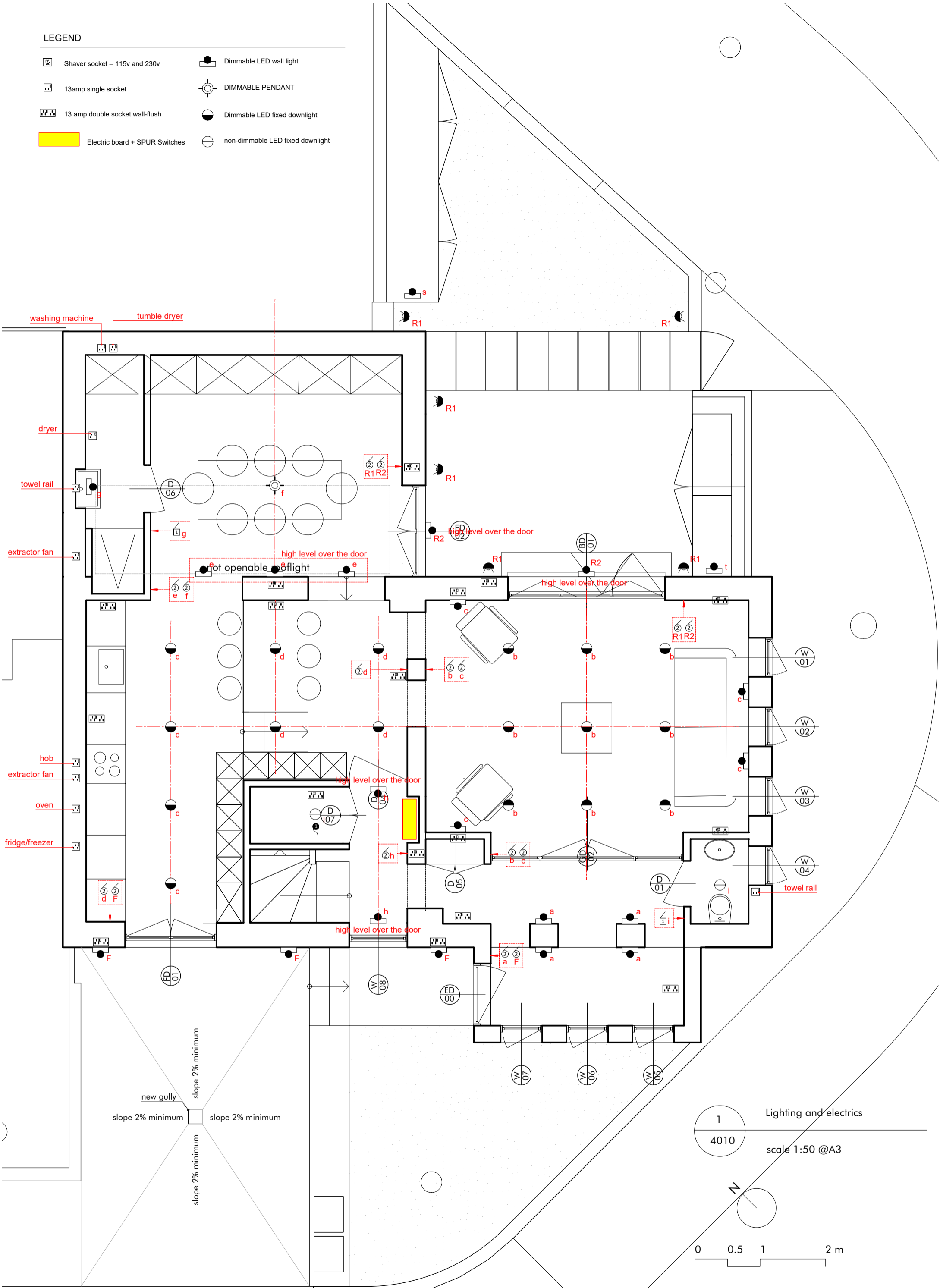

1
4010
Lighting and electrics
scale 1:50 @A3

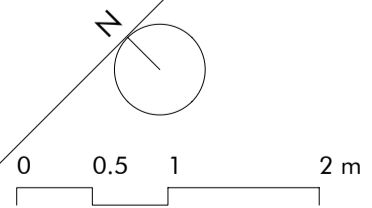

Revision Release date Drawn/Checked NOTES

archetypes.
design
projects@archetypes.design | archetypes.design | 07473 949960

PROJECT ADDRESS CLIENT
London SE16 6RZ Alfredo and Ana Bianco

DRAWING TITLE DRAWING NO. PURPOSE OF ISSUE SCALE FORMAT
Lighting and electrics AD22.05 MDR 4010 Preliminary Pricing 1:25 @ A3

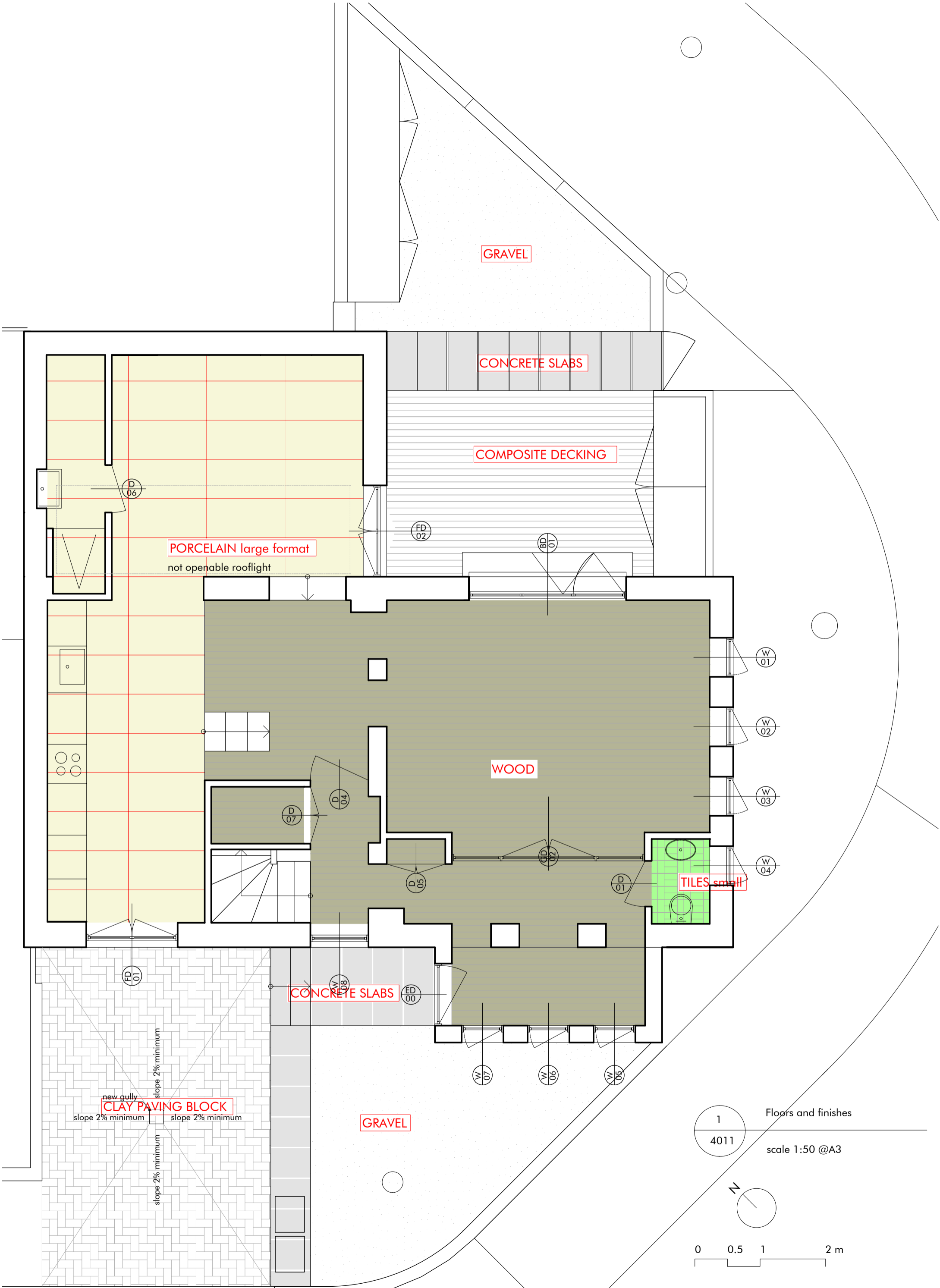

1
4011
Floors and finishes
scale 1:50 @A3

0 0.5 1 2 m

Revision Release date Drawn/Checked NOTES

archetypes.
design

projects@archetypes.design | archetypes.design | 07473 949960

PROJECT
Finishes
DRAWING NO
AD22.05 MDR 4011

ADDRESS
London SE16 6RZ

CLIENT
Alfredo and Ana Bianco

PURPOSE OF ISSUE
Preliminary Pricing

SCALE
1:50

FORMAT
A3

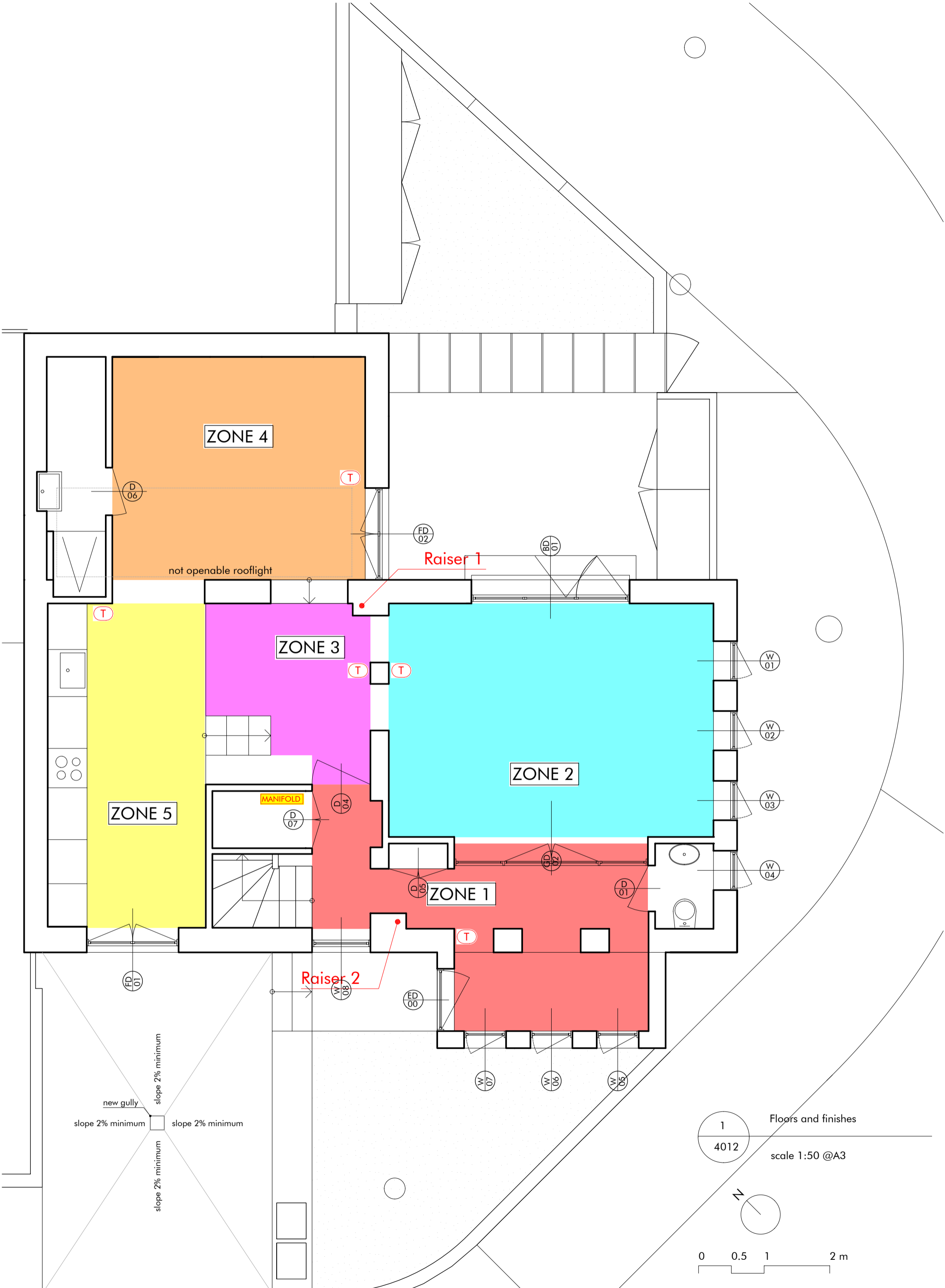

new gully
 slope 2% minimum
 slope 2% minimum
 slope 2% minimum
 slope 2% minimum

1
 4012
 Floors and finishes
 scale 1:50 @A3

0 0.5 1 2 m

Revision Release date Drawn/Checked NOTES

FLUSH FRAMELESS DOORS (Eclisse or similar)

Standard size door (01, 06), and floor to ceiling full width (04)
 Panel to be primed and painted same color as the wall
 including hinges and handles

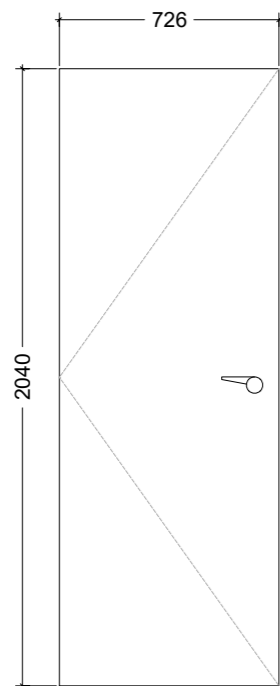

D
01

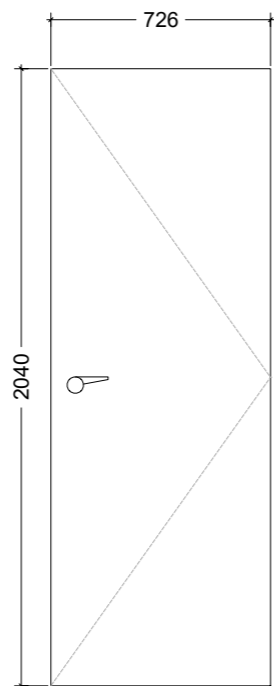

D
06

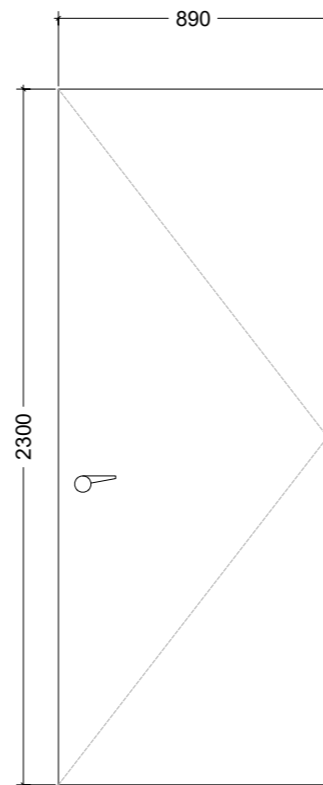

D
04

JOINERY DOORS

Floor to ceiling double doors
 MDF + melamine finishes to surface and edges
 including hinges and handles

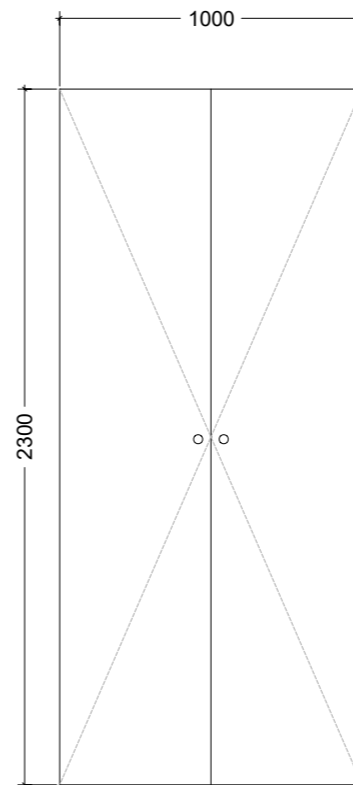

D
05

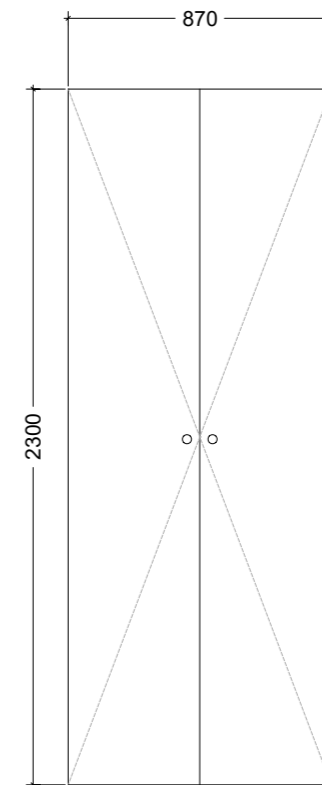

D
07

1
4013
Solid doors
scale 1:25 @A3

FRENCH DOOR

x 2 FD 01 FD 02
opening inward

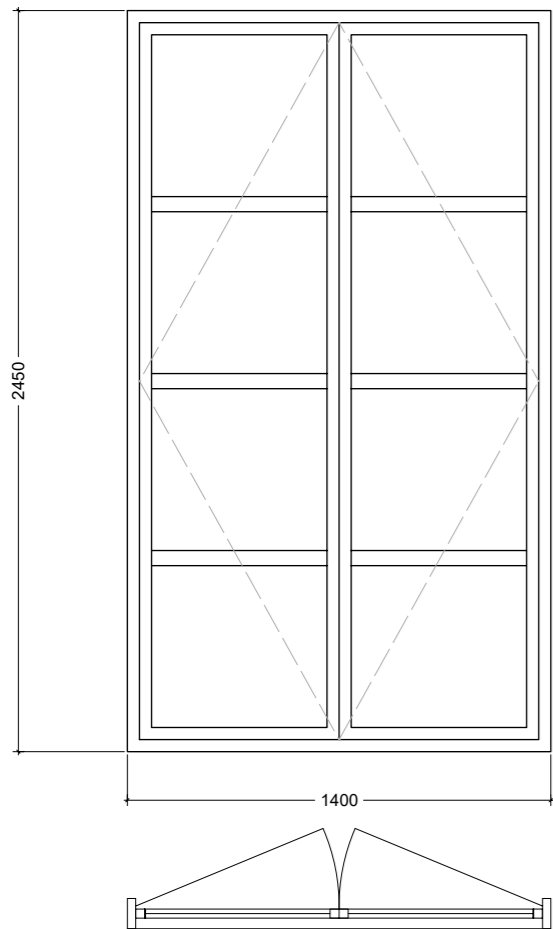

FIXED GLAZING

x 1 W 08

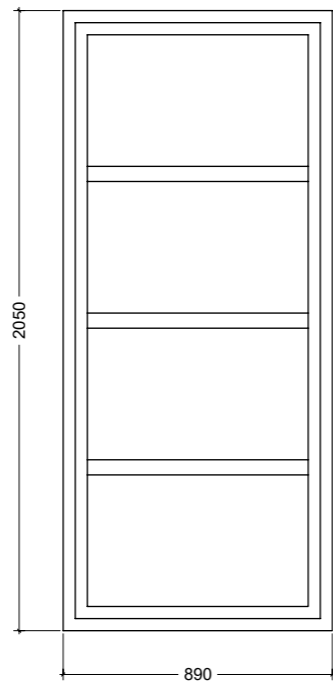

INTERNAL GLAZED DOUBLE DOOR AND SIDE SCREEN

x 1 GD 02

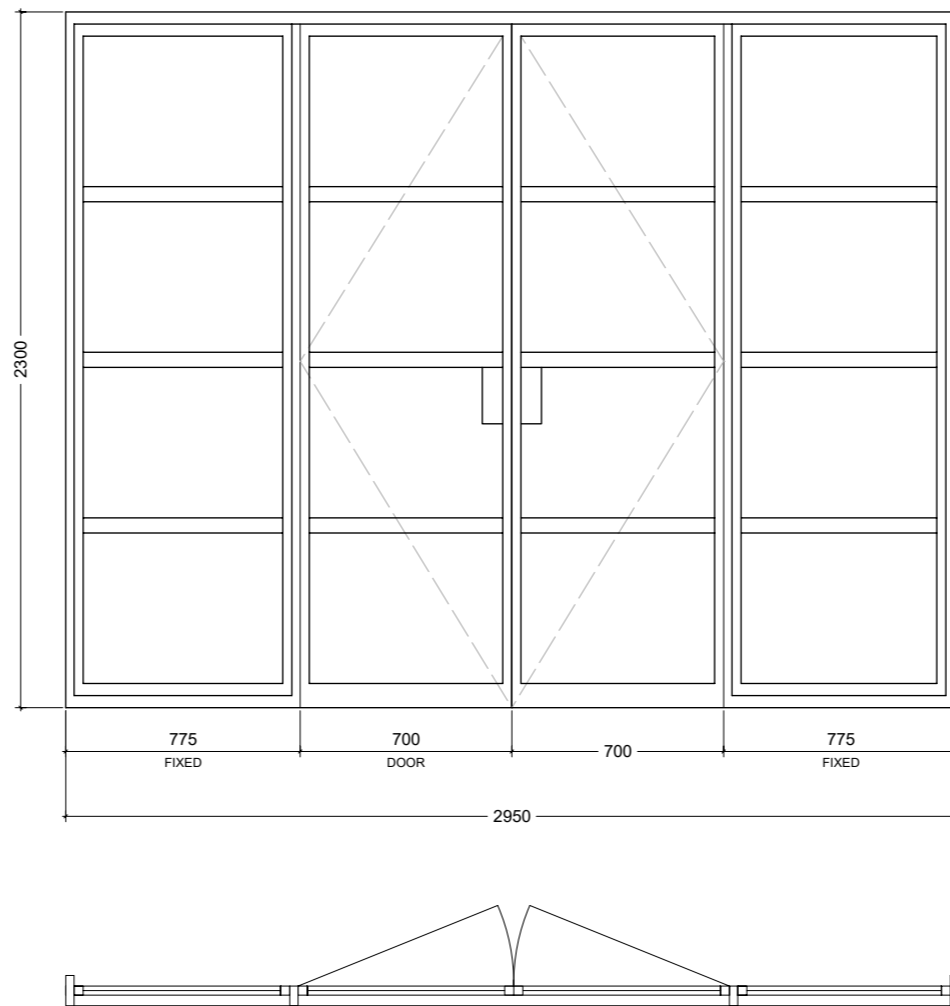

BIFOLD DOOR

x 1 BD 01
opening outward

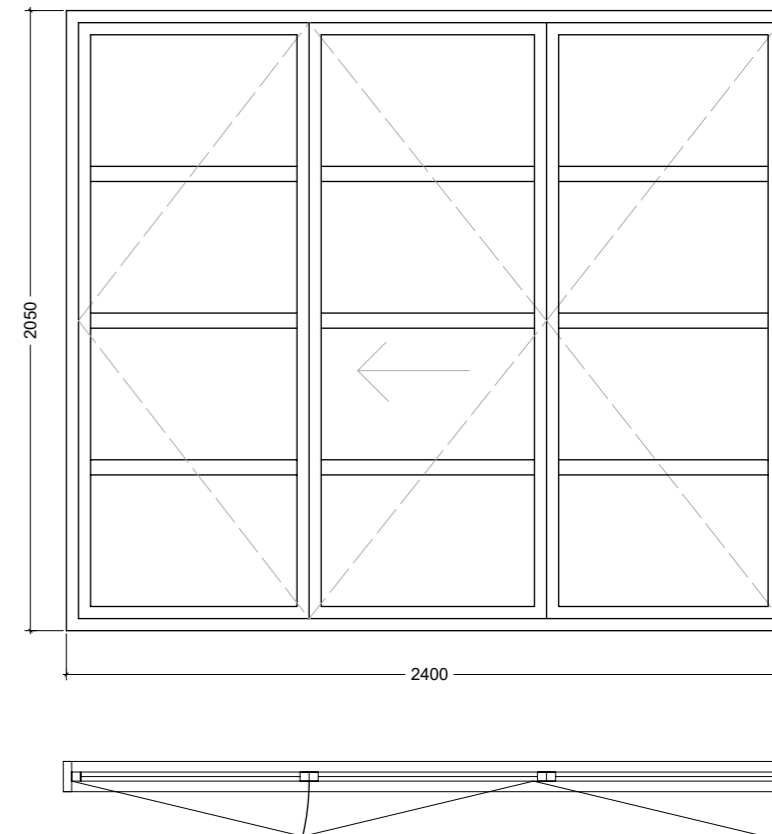

EXTERNAL FRONT DOOR

x 1 ED 00
Aluminium or Composite

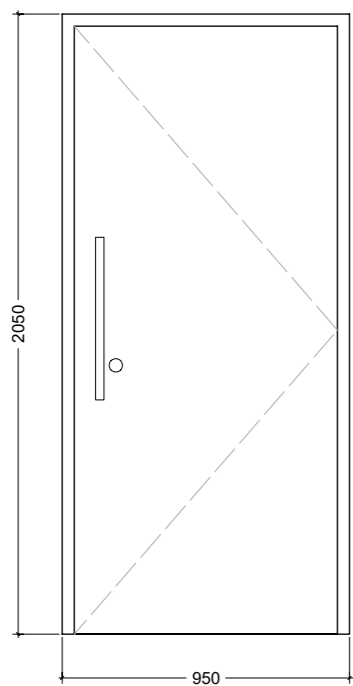

CASEMENT WINDOW

x 4 W 01 W 02 W 03 W 04
opening outward

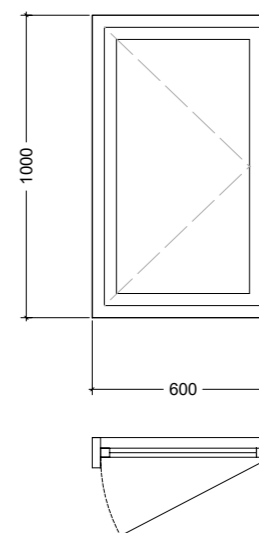

CASEMENT WINDOW

x 3 W 05 W 06 W 07
opening outward

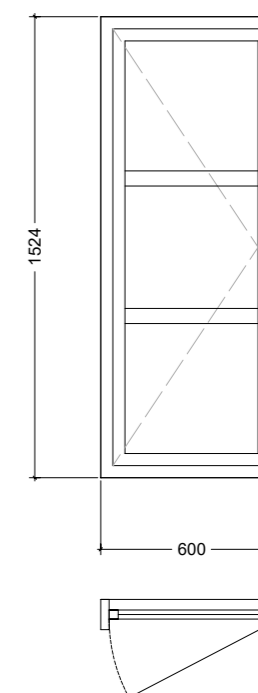

1
4014
Glazed and metal doors and windows
scale 1:25 @A3

NOTE: ALL EXTERNAL WINDOWS AND GLAZED DOOR TO HAVE TRICKLE VENTS