

REVISIONS		
ISSUE	DATE	DESCRIPTION
A	09/02/2023	Initial release.

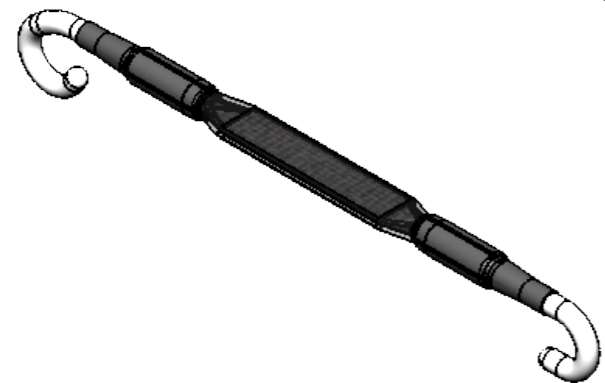
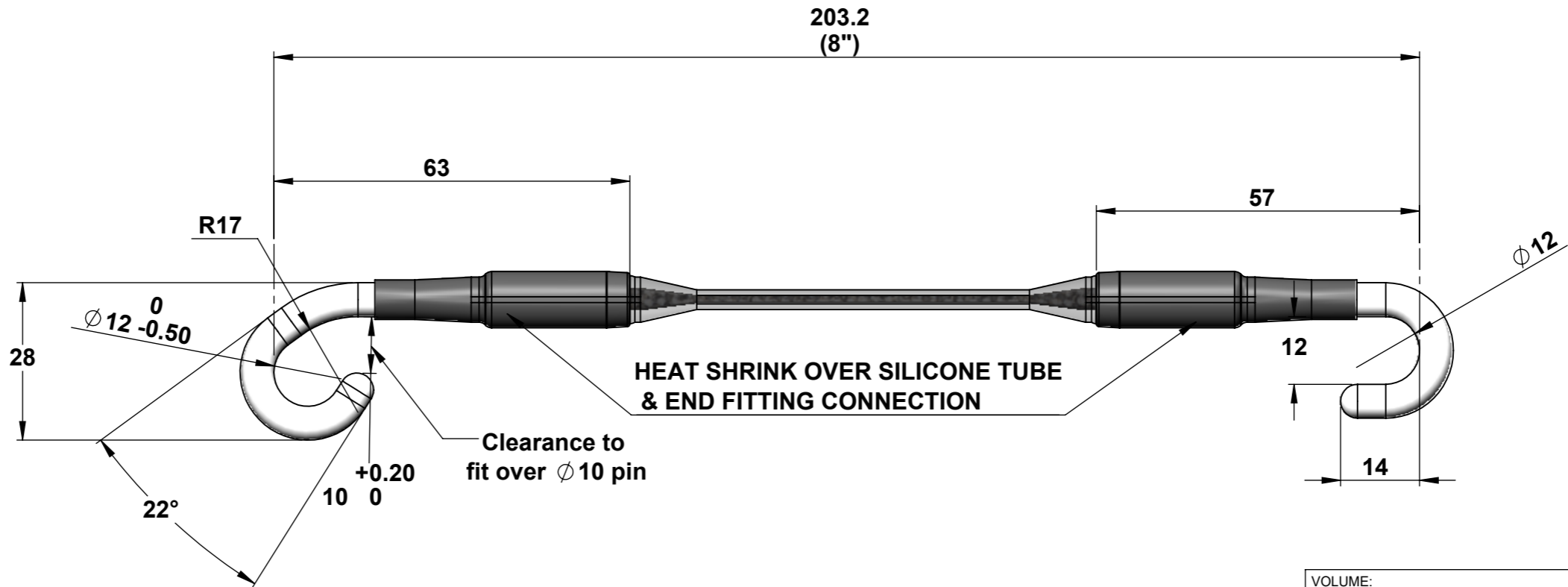
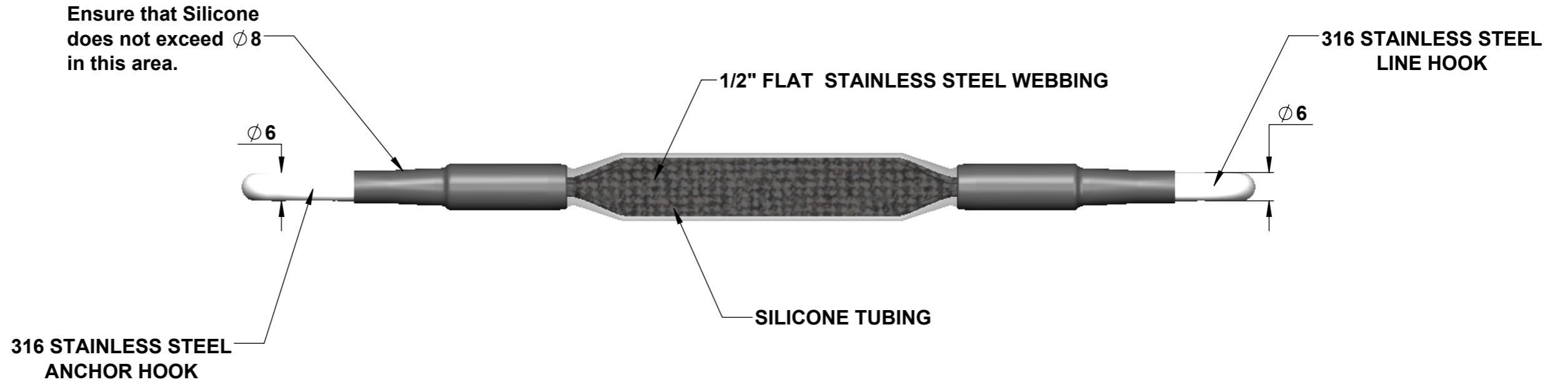

COPYRIGHT:
 THIS DOCUMENT IS THE PROPERTY OF DALDORADO PTY. LTD. AND IS PROVIDED ON AN IN-CONFIDENCE BASIS. IT MAY NOT BE COPIED OR REPRODUCED WITHOUT THE PRIOR PERMISSION OF DALDORADO OR IT'S AUTHORISED AGENT.
 ALL DIMENSIONS IN mm UNLESS STATED OTHERWISE

TOLERANCE UNLESS SPECIFIED (Injection Moulding)

0 to 10mm	±0.20
11 to 25mm	±0.3
26 to 50mm	±0.4
51 to 120mm	±0.6
121 to 250mm	±1.0
251 to 400mm	±1.3
401 to 500mm	±1.6
501mm AND OVER	±0.35%
ANGULAR	±0°30'

THIRD ANGLE PROJECTION DO NOT SCALE IF IN DOUBT ASK

DRAWN: G KOTZ
DATE: 09 FEB 2023
CHECKED: M TURNER
APPROVED: R LAWSON
CLIENT: R.LAWSON

VOLUME:
 MATERIAL:
 FINISH: COLOUR:

ISSUED FOR:

<input type="checkbox"/>	REFERENCE
<input type="checkbox"/>	PRODUCTION
<input checked="" type="checkbox"/>	QUOTATION ONLY
<input type="checkbox"/>	CLIENT APPROVAL
<input type="checkbox"/>	PROTOTYPE
<input type="checkbox"/>	PRELIMINARY TOOLING

DESCRIPTION: UNIT LANE LINE EXTENSION - 8"

FILE NO: Unit Lane Line Extension-8-Inch-01

SCALE **1:1**

SHEET 1 OF 1 **A3**