

TOP VIEW
(RISER & SAFTEY COVERS REMOVED)

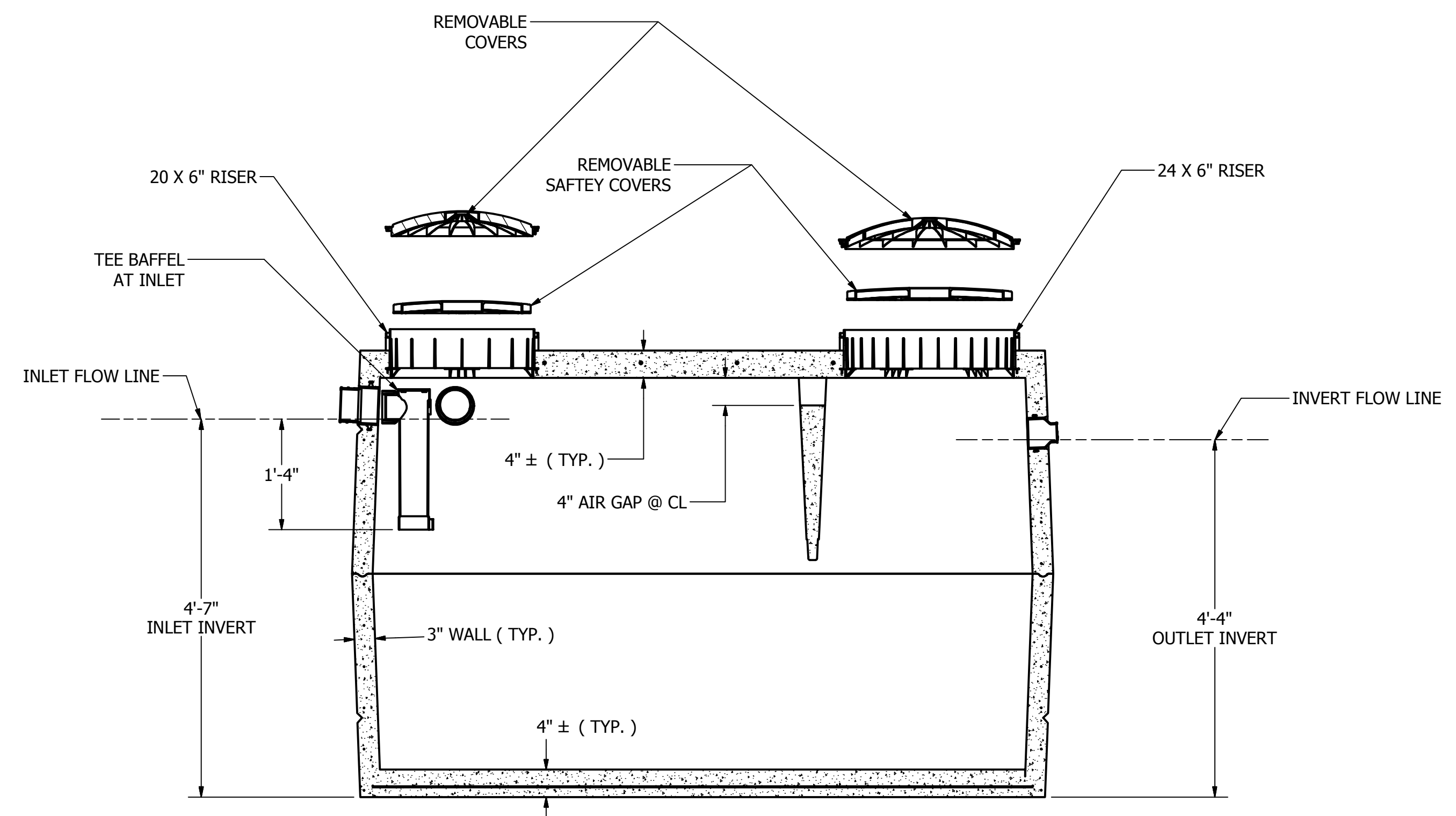

SECTION A-A

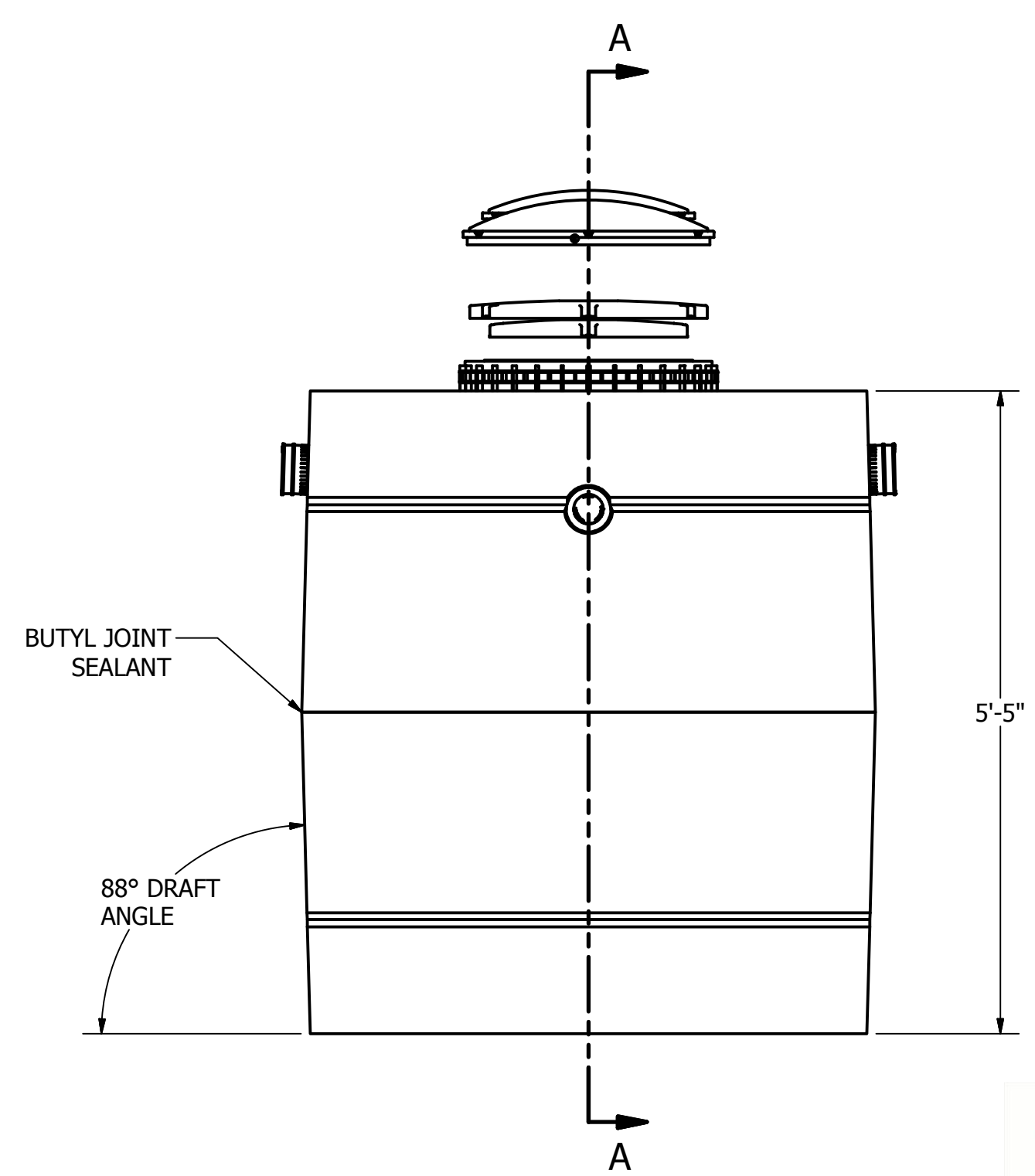

NOTES

1. JOINT SEALANT IS BUTYL RUBBER MASTIC TYPE SEAL THAT CONFORMS TO LATEST AASHTO SPECIFICATION M-198. MEETS FEDERAL SPECIFICATION SS-S-0021(210-A).
2. REINFORCING STEEL REBAR CONFORMS TO LATEST ASTM SPECIFICATION A615.
3. REINFORCING STEEL WELDED WIRE FABRIC CONFORMS TO LATEST ASTM SPECIFICATION A185.
4. CONCRETE COMPRESSIVE STRENGTH - 4500 PSI AT 28 DAYS.
5. METHOD OF MANUFACTURE: WET CAST.
6. SECTIONS ARE MONOLITHIC.
7. PIPE INLET AND OUTLET SEALS CONFORM TO ASTM C 1944 OR 923.
8. ALL CONCRETE AND PLASTIC COVERS HAVE TANK ENTRY WARNING PLACARDS. (TWO COMPARTMENT TANK AND DANGER POISON GAS)
9. ALL PLASTIC HANDLES HAVE REBAR ATTACHED.
10. MAXIMUM 4 FEET OF COVER OVER TANK.
11. OUTLET FILTER CAN BE ORDERED FOR ADDITIONAL COST.
12. USE OF SCHEDULE 40 PIPE (MEETING ASTM-D1786 OR 2665) OR INTERNAL PIPE SUPPORTS ARE REQUIRED WHEN UTILIZING SIDE ENTRY PORTS AT INLET END.
13. CONCRETE COVERS MUST REMAIN IN PLACE UNLESS A SECONDARY SAFETY DEVICE IS INSTALLED.

TANK DESIGN SPECIFICATION CONFORMS TO LATEST ASTM DESIGNATION C1227.

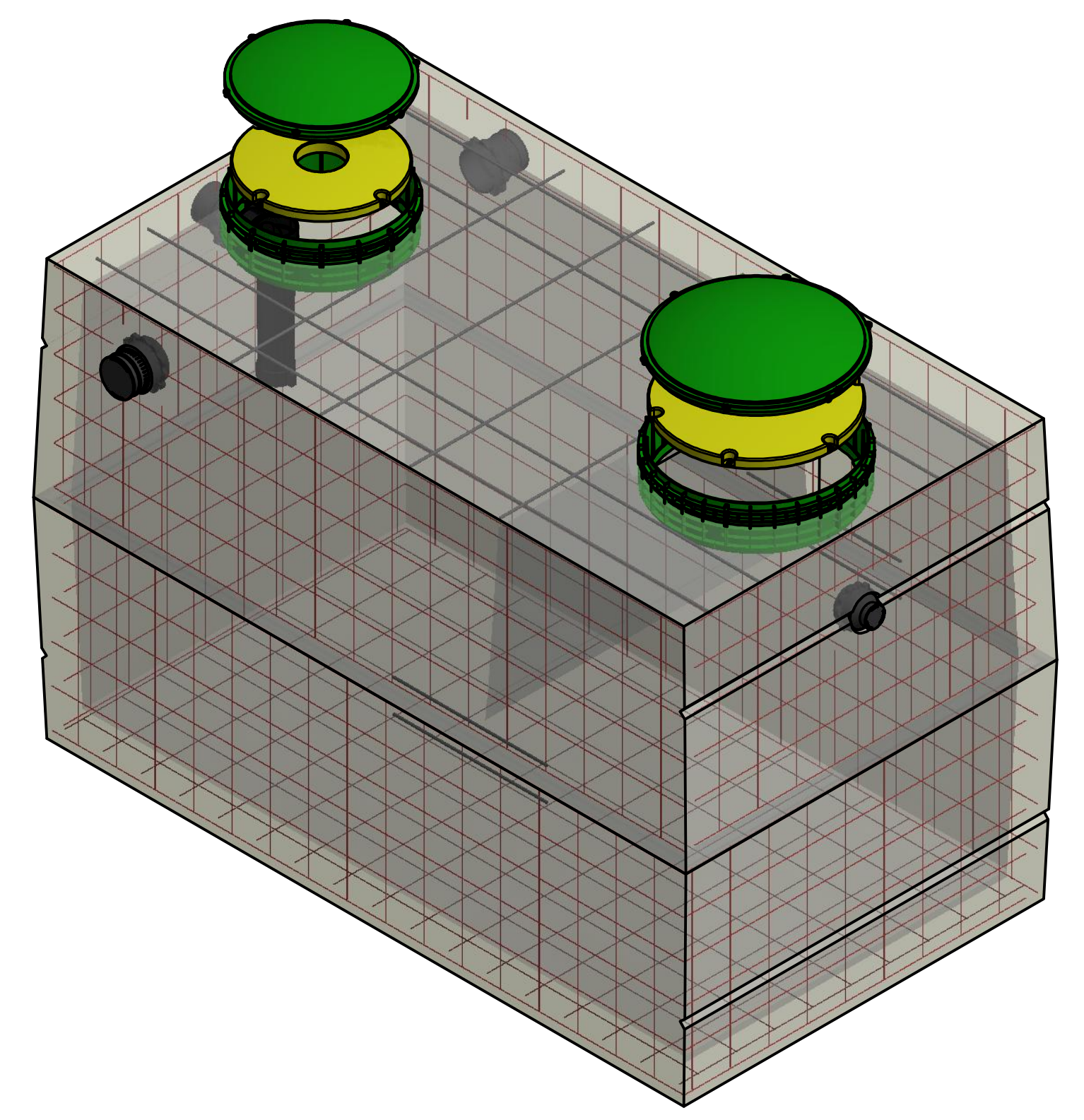

SCALE: 1 / 15
ALL VIEWS

CONNECTICUT CONCRETE PRODUCTS, LLC

THIRD ANGLE PROJECTION 	DIMENSIONS ARE IN INCHES TOLERANCES UNLESS NOTED: XX ± 0.1 XXX ± 0.02 XXXX ± 0.005 ANGLES MACH ± 0.5 BEND ± 2.0 DRILLED HOLES +0.010/-0.000 SURFACE FINISH AS REQUIRED BY TOLERANCE UNLESS NOTED OTHERWISE	DRAWN R Campbell	12/6/2016	10 MEADOW LANE, STAFFORD SPRINGS, CT 06076 PHONE 860-851-9132 Visit: precastct.com
		CHECKED		TITLE
		QA		1000 GALLON PUMP CHAMBER
		MFG		SIZE
		APPROVED		DWG NO
		EST MASS LBS. 8,300 ± 5%		1000 GAL-PC
				REV
				A
				SCALE
				SHEET 1 OF 1