

# NORCAL CLASSIC Tracy California

MAY 31<sup>ST</sup>  
THROUGH  
JUNE 1<sup>ST</sup>

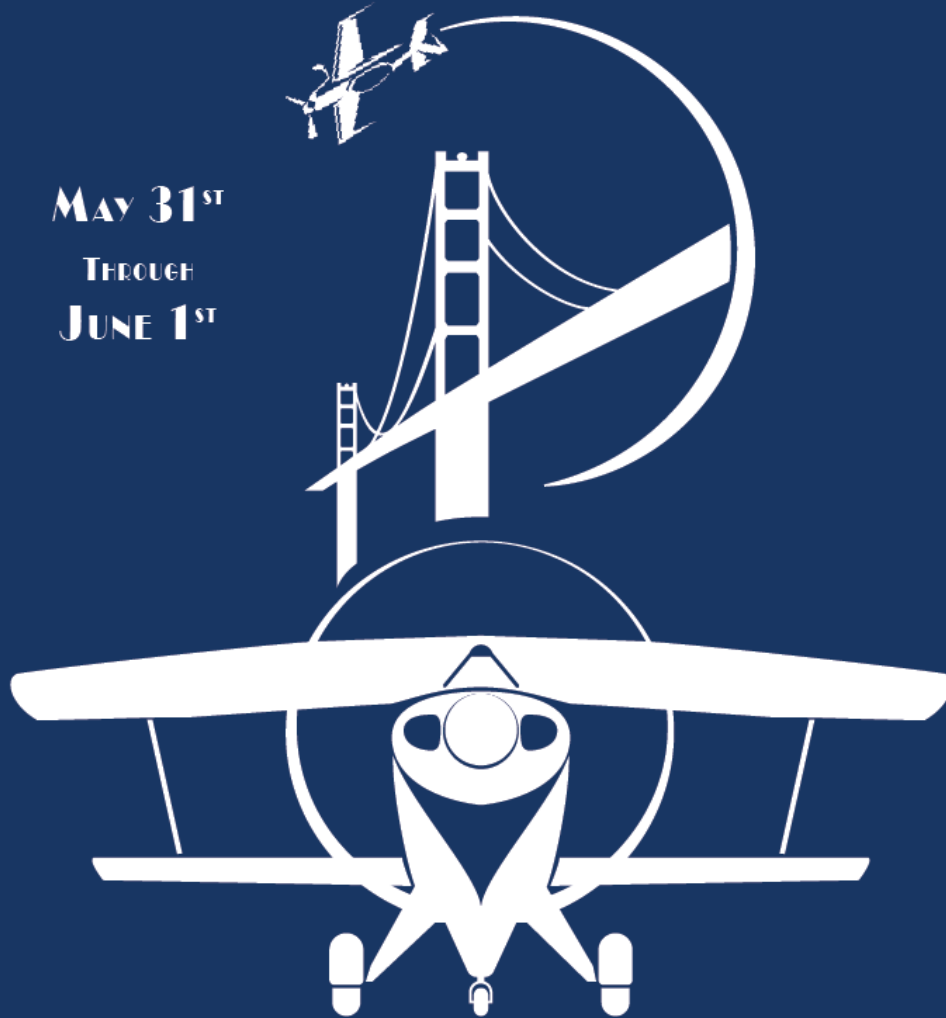

2024



# Our Valued Sponsors!

hackerone



se2quel Partners



**SOUTH VALLEY**  
ORAL AND FACIAL SURGERY

**Special Thanks To**  
**Tom Siebel**                      **Kevin Smith**

# Welcome Spectators

Hello and thank you for coming! There is a lot to know, firstly, this is NOT an airshow and your personal safety is our primary objective. We recognize the desire to get close to the cool airplanes but, due to various rules, we cannot allow the general public access to the aircraft parking area or “ramp”. We encourage you to observe from the Airport Park, and its associated parking lot. Access to the ramp area is restricted for *YOUR* safety. These airplanes have poor pilot visibility on the ground and a spinning propeller is deadly. We welcome you to observe the aircraft from along the fence.

## Parking

Parking is permitted in designated areas. The parking lot East of the Airport Park is acceptable for parking; however, you cannot sit in the trunk of your car and spectate from there as it is considered too close to the aerobatic area. Spectators must remain on the west side of the short height fence that runs parallel to the Airport Park. If you are in this area loitering or sitting, you will be asked to move.

## Hi from Airport Manager, Paula Jessup

The City of Tracy would like to welcome everyone to Tracy Municipal Airport for the 2024 Northern California regional competition of the International Aerobatic Club. We hope that you, your friends, and your family enjoy our hospitality during this amazing event. If you need anything, please do not

## Hello from IAC Chapter 38 President, Joe McMurray

We are grateful that we can share our love of aviation and passion for competitive aerobatics with the Tracy community! This is a gathering of highly skilled pilots who are competing against one another. Competition aerobatics demands very precise, planned flying that is judged similarly to Olympic figure skating and springboard diving. The sport places incredible

# Message from Our Organizers

We hope you enjoy this year's contest and the gala dinner! If you have any comments or feedback on how we can make next year's event even better please email either Hickmansmith\_dean@yahoo.com or jakelvk@gmail.com  
In the meantime, have fun and fly safe.

## Schedule of Events

Wednesday, May 29, 2024

10:00 AM - Set Up Day Begins

Practice Flights begin after completion of set up activities.

ALL DAY - Aircraft Arrivals

Thursday, May 30, 2024

10:00AM - Registration Opens

10:00 AM - Practice Slots Open

7:00 PM Registration Closes ( Late arrivals must contact CD prior to 7PM)

ALL DAY - Aircraft Arrivals & Practice Flights

Friday, May 31, 2024

7:00 AM - Pilot Briefing: Tracy Airport

8:00 AM - First aircraft airborne

5:00 PM - Targeted end of Known and Free flights

7:00 PM- Aerobatic Box Closes for the day

Saturday, June 1, 2024

7:00AM - Pilot Briefing: Tracy Airport

8:00AM - First aircraft airborne

At the conclusion of all competitors having flown all their flights:  
(Target time 3:00PM)

4 Minute Freestyle

Demonstration By Sukhoi West Aerobatic Team

## How Does It Work?

Each competitor in categories from beginner to expert flies three flights. Competitors fly paths in the sky known as 'figures'. Figures can be a combination of loops, lines, rolls and spins. These figures are graded on factors such as precision of the lines and angles, symmetry and other factors spelled out in the official contest rules.

Flights are graded by a team of five judges who are assisted by two people each. These judges grade each individual figure as well as the way the sequence is positioned within the competition area called the 'aerobatic box'.

Judges have a printed copy of the sequence of figures each pilot will fly. The figures are graphically represented by symbols in a system known as Aresti. The graphical symbol representing each figure is also assigned a difficulty

## The Aerobatic Box

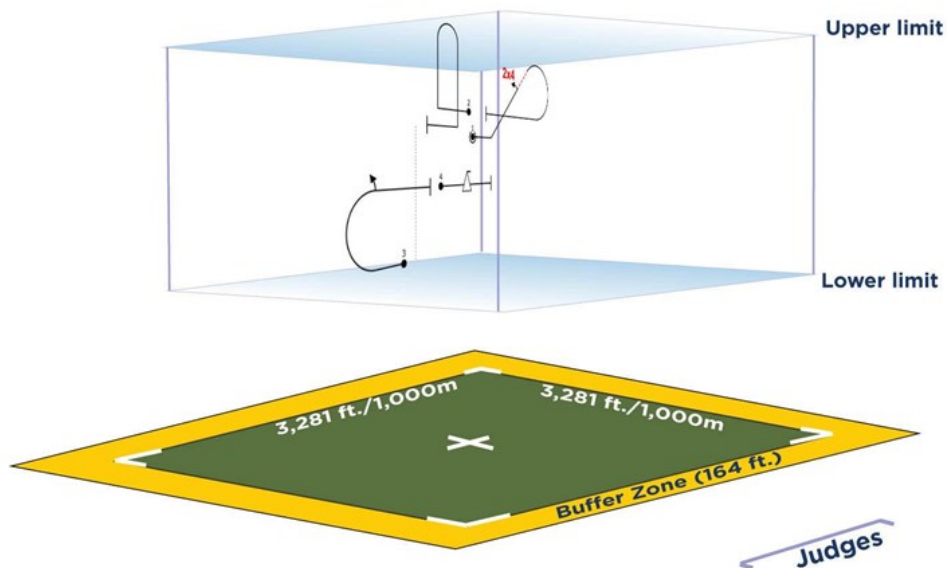

# Competition Categories

**Primary:** The primary sequence is composed of six simple figures. All pilots fly the same sequence three times. This is considered the entry level category.

**Sportsman:** All sportsman pilots are required to fly the known compulsory sequence. Most pilots fly the known sequence on all three flights however sports in pilot have the option of flying a free sequence for their second and third flights.

**Intermediate:** In addition to a more complex known compulsory, intermediate pilots are also required to fly an

## The Primary Sequence

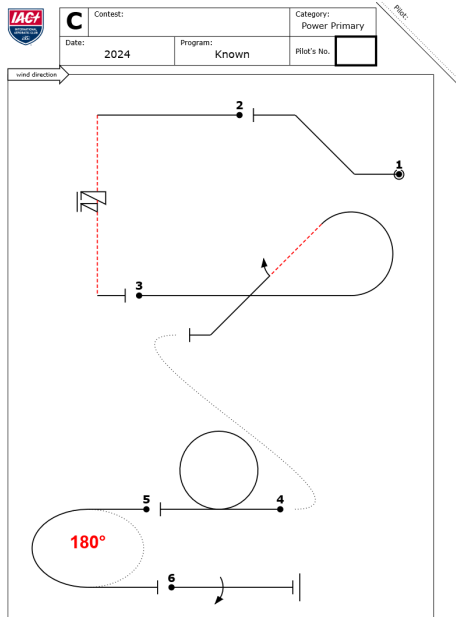

## The Unlimited Sequence

	2024	Form C
Pilot ID: <input style="width: 80px;" type="text"/>	IAC Unlimited Known	Page # <input style="width: 20px;" type="text"/>

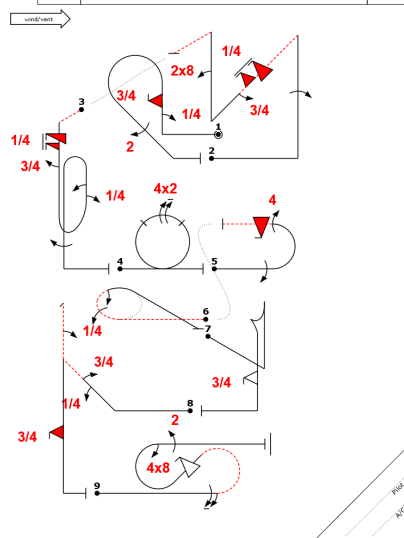

**Advanced:** The advanced pilot must fly and even more complex and known and unknown compulsory as well as a free program.

**Unlimited:** Unlimited pilot flies the most difficult and complex figures of all competition pilots. They must fly an extremely high performance airplane capable of flying required figures. In addition to the known, unknown and free programs, unlimited pilots can choose to